

ABB OPTIONS

SACE, SAFUR and JBR brake resistors

Hardware manual



SACE, SAFUR and JBR brake resistors

Hardware manual

Table of contents



3AXD50001283780 Rev B
EN
Original instructions
EFFECTIVE: 2025-09-25

Table of contents

1 Safety instructions

Contents of this chapter.....	7
Safety messages.....	7
Electrical safety precautions.....	8

2 Operation principle

3 Planning the braking system

Selecting the drive, brake chopper and brake resistor.....	11
Selection example.....	12
Selecting a custom brake resistor.....	13
Selecting and routing the brake resistor cables.....	13
Minimizing electromagnetic interference.....	13
Maximum cable length.....	14
EMC compliance of the complete installation.....	14

4 Mechanical installation

Placing the brake resistors.....	15
SACE type.....	16
Free space.....	16
SAFUR type.....	17
Free space.....	17
JBR type.....	19
Free space.....	19

5 Electrical installation

Measuring the insulation resistance of the brake resistor circuit.....	21
Protecting the system in brake circuit fault situations.....	22
Protecting the system in cable and brake resistor short-circuit situations.....	22
Protecting the system against thermal overload.....	22
Protecting the brake resistor cable against short-circuits.....	23
Connection procedure.....	24

6 Start-up

7 Dimension drawings

Contents of this chapter.....	27
SACE resistors.....	28
SAFUR resistors.....	30
JBR resistors.....	32

8 Technical data

SACE resistors.....	35
SAFUR resistors.....	35



6 Table of contents

JBR resistors..... 36
Degree of protection, thermal time constant and insulation resistance of the resistor..... 36

9 Declarations of conformity

10 Circuit diagrams

SACE resistors..... 39
SAFUR resistors..... 40
JBR resistors..... 40

Further information



1

Safety instructions

Contents of this chapter

This chapter contains the safety instructions which you must obey when you install, start-up, operate and do maintenance work on the brake choppers and brake resistors. If you ignore the safety instructions, injury, death or damage can occur.

Safety messages

These safety messages help to prevent personal injury and damage to the equipment. The hazard levels comply with standard ANSI Z535.6.

The manual uses these warning symbols:



▲DANGER Indicates a hazardous situation which, if not avoided, will result in death or serious injury.



▲WARNING Indicates a hazardous situation which, if not avoided, could result in death or serious injury.



▲CAUTION Indicates a hazardous situation which, if not avoided, could result in minor or moderate injury.

NOTICE Is used to address practices not related to physical injury, but which can result in equipment damage.

Electrical safety precautions

These electrical safety precautions are for all persons who do work on the drive, motor cable or motor.



▲WARNING Obey these instructions. If you ignore them, injury or death, or damage to the equipment can occur. If you are not a qualified electrical professional, do not do electrical installation or maintenance work. Do these steps before you do installation or maintenance work.

1. Prepare for the work.
 - Make sure that you have a work order.
 - Do an on-site risk assessment or job hazard analysis.
 - Make sure that you have the correct tools available.
 - Make sure that the workers are qualified.
 - Select the correct personal protective equipment (PPE).
 - Stop the drive and motor(s).
2. Clearly identify the work location and equipment.
3. Disconnect all possible voltage sources. Make sure that connection is not possible. Lock out and tag out.
 - Open the main disconnecting device of the drive
 -
 - If there is a permanent magnet motor connected to the drive, disconnect the motor from the drive with a safety switch or by other means.
 - Open the main isolating device of the drive.
 - Disconnect all dangerous external voltages from the control circuits.
 - After you disconnect power from the drive, wait 5 minutes to let the intermediate circuit capacitors discharge before you continue.
4. Protect other energized parts in the work location against contact and take special precautions when close to bare conductors.
5. Measure that the installation is de-energized. Use a high-quality voltage tester.
 - Before and after you measure the installation, verify the operation of the voltage tester on a known voltage source.
 - Make sure that the voltage between the input power terminals of the drive (L1, L2, L3) and the grounding (PE) busbar is zero.
 - Make sure that the voltage between the output power terminals of the drive (U, V, W) and the grounding (PE) busbar is zero.
 - Make sure that the voltage between the drive DC terminals (UDC+ and UDC-) and the grounding (PE) terminal is zero.
6. Install temporary grounding as required by the local regulations.
7. Ask for a permit to work from the person that is responsible for the electrical installation work.

The complete safety instructions for the drive are given in the drive hardware manual. Read and follow the complete safety instructions before working on the drive.



Operation principle

The brake chopper handles the extra energy generated by the motor during a quick deceleration. The extra energy increases the DC link voltage of the drive. The chopper connects the brake resistor to the DC link whenever the voltage is more than the operation limit of the chopper. The energy consumed by the resistor losses lowers the voltage until it is less than the limit at which the chopper stops.

The drive may have a built-in brake chopper as standard or the drive can be equipped with optional brake chopper (+D150). Brake resistors are available as add-on kits.

3

Planning the braking system

Selecting the drive, brake chopper and brake resistor

For the ratings of the brake choppers and resistors, refer to the resistor braking technical data in the drive hardware manual.

1. Define the basic data: maximum power generated by the motor during braking (P_{br}), braking time (t_{br}) and braking cycle time (T).
 2. Select the drive. Take its resistor braking capacity into account. The power rating of the drive and brake chopper (P_{brmax}) must be greater than or equal to P_{br} .
 3. Make sure that the ABB default brake resistor assembly can dissipate the braking energy. The energy generated by the motor during one resistor heat dissipation period (400 s) must be equal to or smaller than the heat dissipation capacity (E_R) of the resistor assembly. If it is not, you cannot use the default ABB resistor assembly. These alternatives are possible:
 - If it is possible, decrease the braking power or braking time, or prolong the braking cycle time.
 - Select a custom brake resistor with high enough heat dissipation capacity. The resistance can not be smaller than the minimum value defined for the chopper.
 - Use multiple of the ABB default brake resistors. Make sure that the total resistance seen from the brake chopper terminals remains unchanged. An example connection is shown below. The connection of an ABB default brake resistor assembly is on the left (two resistors). The equivalent multiple resistor connection is on the right (8 resistors). The heat dissipation capacity is four times bigger.
-

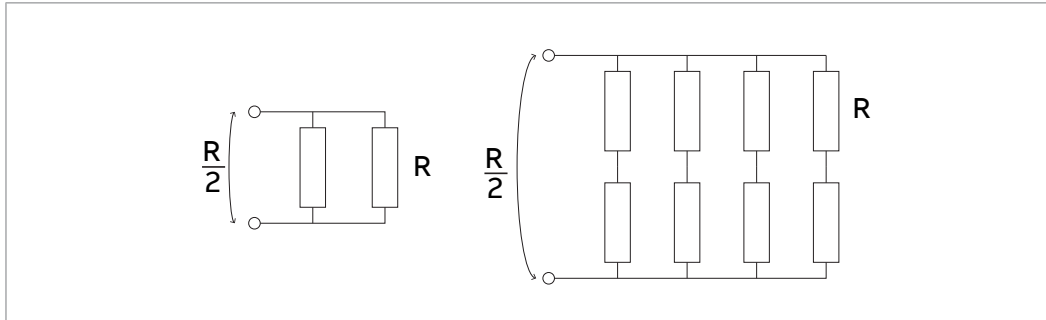

Selection example

In this example, motor generates 300 kW power during braking. Braking time is 15 s every third minute.

1. Define the basic data:
 $P_{br} = 300 \text{ kW}$, $t_{br} = 15 \text{ s}$ and $T = 180 \text{ s}$.
2. Select the drive, brake chopper and default resistor combination:
 P_{brmax} value for the drive size ...-585A-4 is 315 kW. Since it is greater than P_{br} , this drive type is suitable for the application.
3. Make sure that the ABB default brake resistor assembly can dissipate the braking energy:
 - The ABB default resistor heat dissipation value (E_R) is 10800 kJ during a 400 s period.
 - Braking energy per each braking cycle is: $300 \text{ kW} \times 15 \text{ s} = 4500 \text{ kJ}$.
 - Number of braking cycles during one resistor heat dissipation period is:
 $400 \text{ s} / 180 \text{ s} = 2.2 \text{ cycles}$.
 - The total energy generated by the motor during the resistor heat dissipation period is: $2.2 \times 4500 \text{ kJ} = 9900 \text{ kJ}$. This value is lower than the ABB default resistor assembly E_R value. Thus, the ABB default brake resistor can be used.

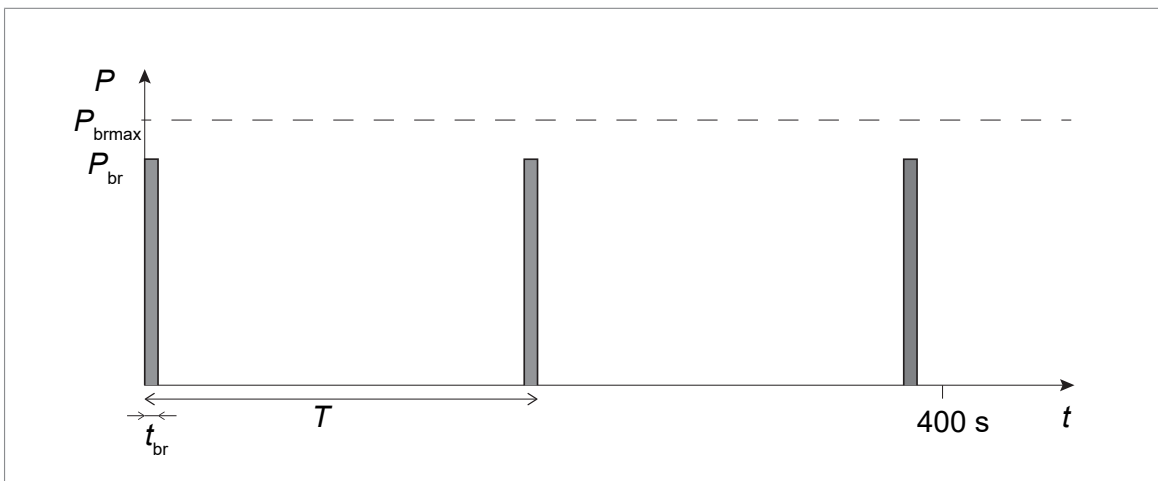

Selecting a custom brake resistor

If you use a resistor other than the default brake resistor,

1. make sure that the resistance of the custom brake resistor is greater or equal than the resistance of the brake default resistor in the rating table:

$R \geq R_{\min}$	
R	Resistance of the custom brake resistor NOTICE Never use a brake resistor with a resistance smaller than R_{\min} . The drive and the chopper are not able to handle the overcurrent caused by the low resistance.
R_{\min}	Resistance of the default brake resistor

2. make sure that the load capacity of the custom brake resistor is greater than the instantaneous maximum power consumption of the brake resistor when it is connected to the drive DC link voltage by the chopper:

$P_r < (U_{DC}^2)/R$							
P_r	Load capacity of the custom brake resistor NOTICE Never use a brake resistor with a resistance smaller than R_{\min} . The drive and the chopper are not able to handle the overcurrent caused by the low resistance.						
U_{DC}	Drive DC link voltage during braking						
	Supply voltage range (V AC)	208...240	380...415	440...480	500	525...600	660...690
	Drive DC link voltage during braking (V DC) when internal brake chopper at 100% pulse width	403	697	806	806	1008	1159
Refer to the drive firmware manual for more information.							
R	Resistance of the custom brake resistor						

Selecting and routing the brake resistor cables

Use the same cable cross-section for the brake resistor cabling as for the drive input cabling to make sure, that the input fuses also protect the brake resistor cable. ABB recommends to use a shielded cable to minimize electromagnetic interference.

■ Minimizing electromagnetic interference

Follow these rules in order to minimize electromagnetic interference caused by the rapid current changes in the brake resistor cables:

- Shield the braking power line completely, either by using shielded cable or a metallic enclosure. Unshielded single-core cable can only be used if it is routed inside a cabinet that efficiently suppresses the radiated emissions.
- Install the cables away from other cable routes.

14 Planning the braking system

- Avoid long parallel runs with other cables. The minimum parallel cabling separation distance should be 0.3 meters.
- Cross the other cables at right angles.
- Keep the cable as short as possible in order to minimize the radiated emissions and stress on chopper IGBTs. The longer the cable the higher the radiated emissions, inductive load and voltage peaks over the IGBT semiconductors of the brake chopper.

Maximum cable length

The maximum length of the brake resistor cable(s) is 10 m (33 ft).

EMC compliance of the complete installation

ABB has not verified that the EMC requirements are fulfilled with external user-defined brake resistors and cabling. The EMC compliance of the complete installation must be considered by the customer.

4

Mechanical installation

Placing the brake resistors

Install the brake resistors outside the drive in a place where they can cool properly.

Arrange the cooling of the brake resistor in a way that:

- no danger of overheating is caused to the brake resistor or nearby materials
- the temperature of the room the brake resistor is located in does not exceed the allowed maximum.

Supply the brake resistor with cooling air or water according to the brake resistor manufacturer's instructions.



▲WARNING The materials near the brake resistor must be non-flammable. The surface temperature of the resistor is high. Air flowing from the resistor is of hundreds of degrees Celsius. If the exhaust vents are connected to a ventilation system, make sure that the material withstands high temperatures. Protect the resistor against contact.

SACE type

- Free space

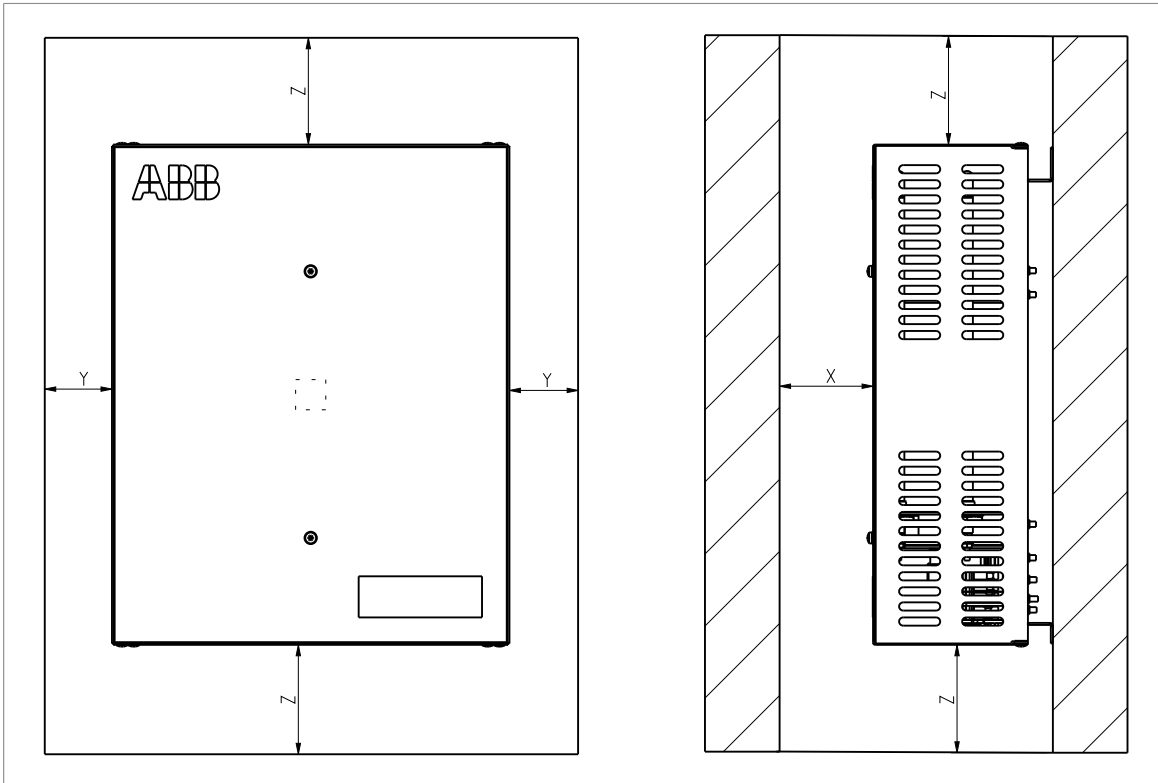

Type	X mm [in]	Y mm [in]	Z mm [in]
SACE 08 RE 44	150 [5.9]	150 [5.9]	300 [11.8]
SACE 15 RE 13			
SACE 15 RE 22			

SAFUR type

- Free space

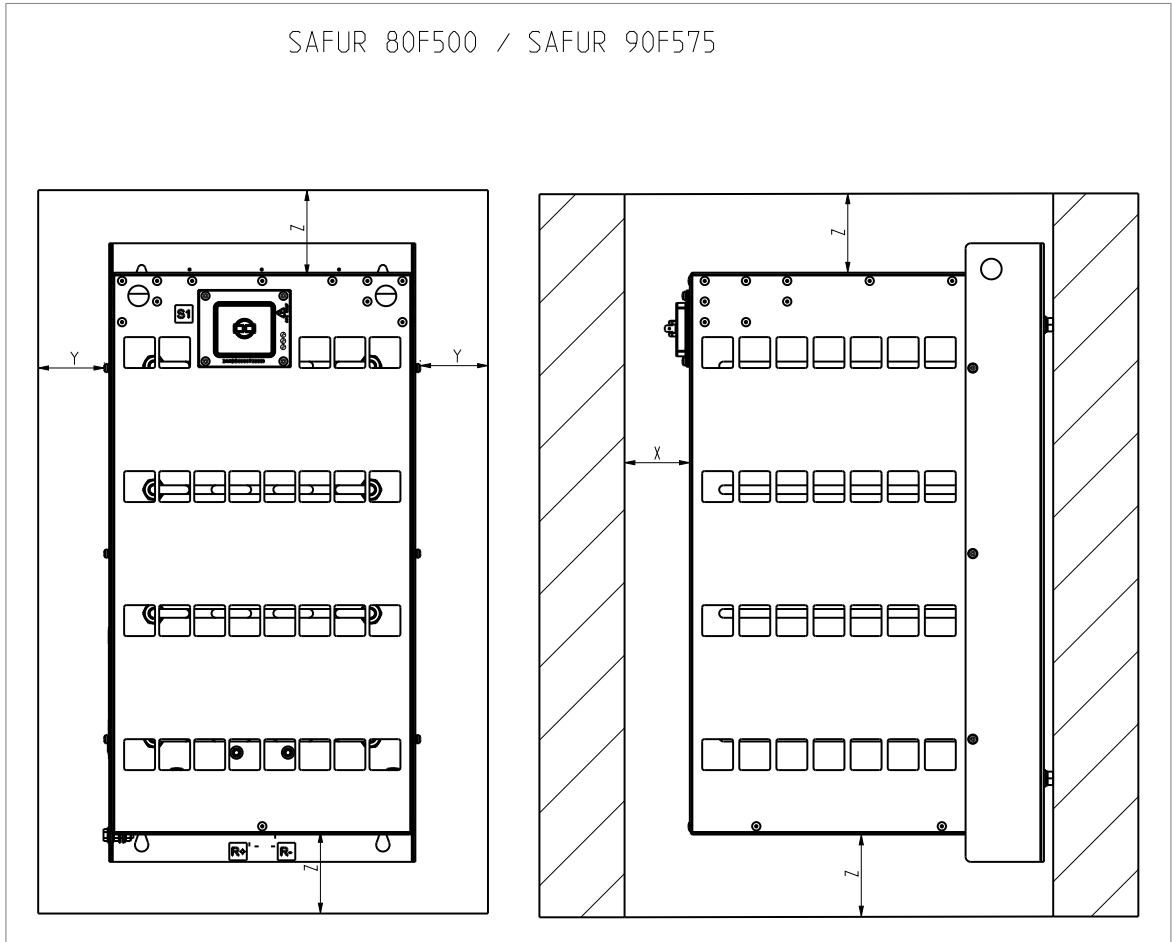

Type	X mm [in]	Y mm [in]	Z mm [in]
SAFUR 80F500	40 [1.57]	40 [1.57]	300 [11.8]
SAFUR 90F575	40 [1.57]	40 [1.57]	300 [11.8]

18 Mechanical installation

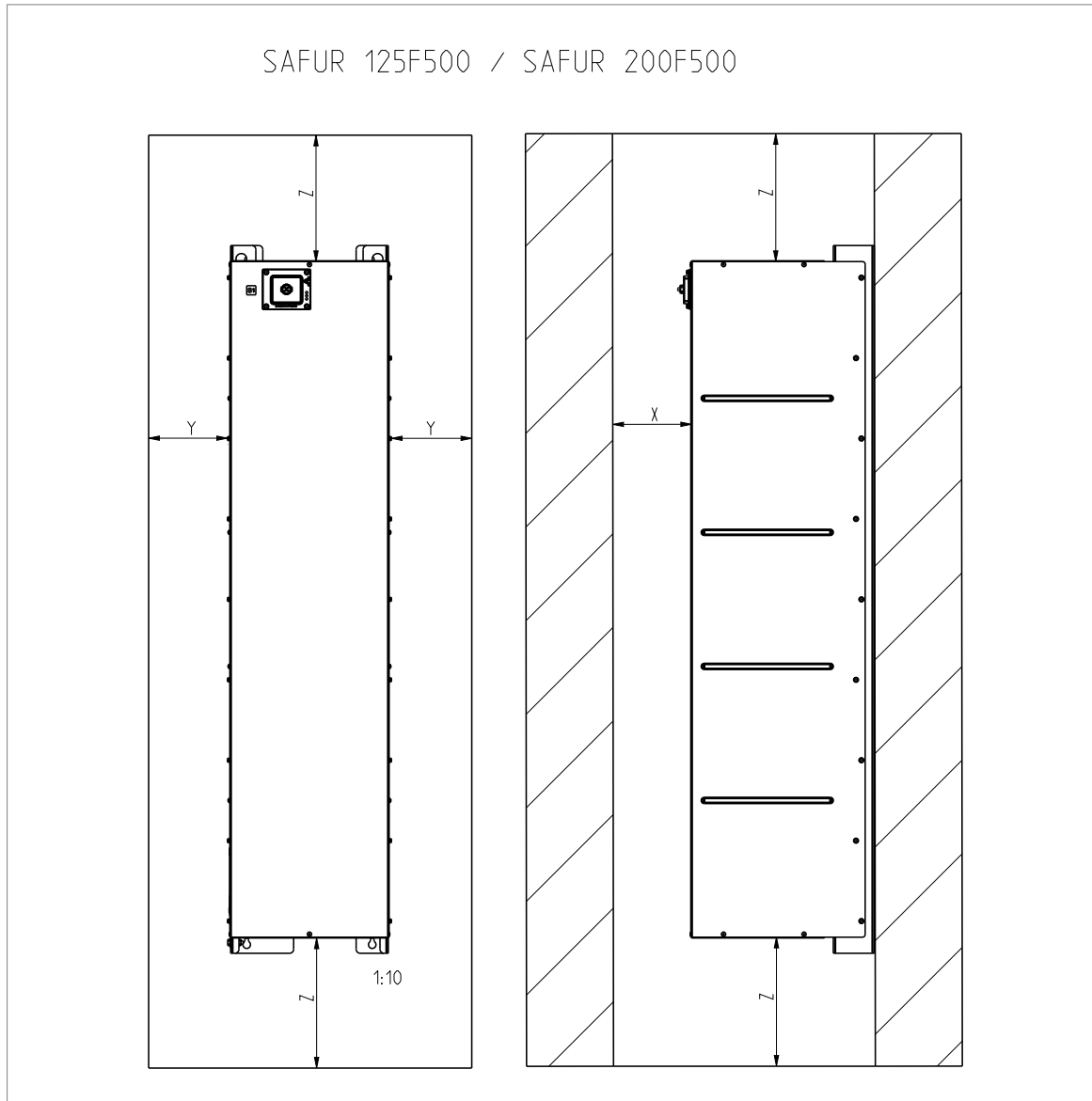

Type	X mm [in]	Y mm [in]	Z mm [in]
SAFUR 125F500	40 [1.57]	40 [1.57]	300 [11.8]
SAFUR 200F575			

NOTICE SAFUR braking resistors are specifically designed for integration within ABB ACS880-BRR cabinets and are not intended for standalone use. Active cooling is necessary to make sure that their operation and thermal management is correct.

Within the ACS880-BRR solution, cooling is supplied by a W2E250-HL06-21 fan, which delivers an airflow of 1275 m³/h at 90 Pa.

If you use SAFUR resistors outside the ACS880-BRR system, it is critical to make sure that your design supplies sufficient airflow to prevent overheating and to make sure that the operation is safe.

JBR type

■ Free space

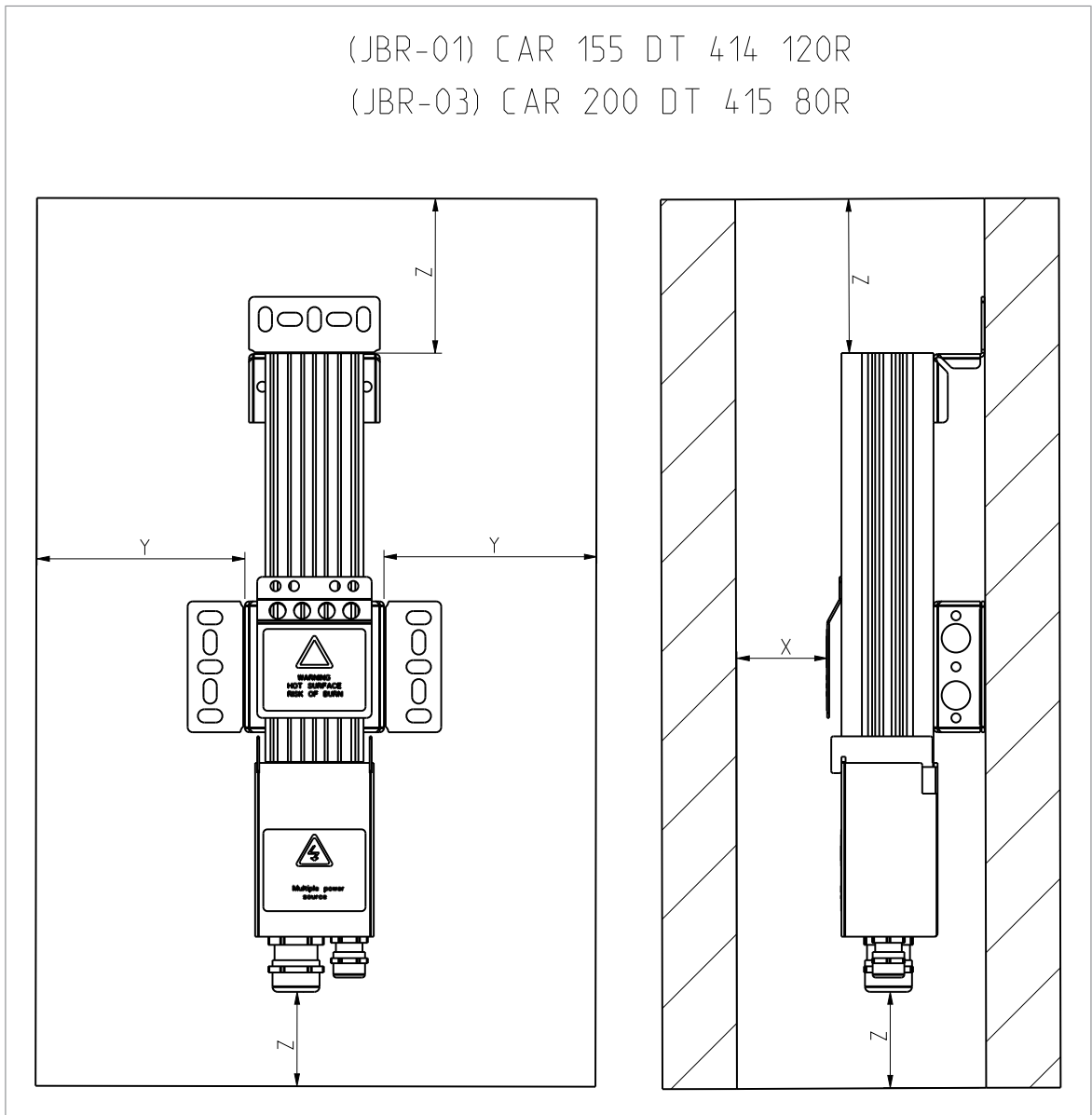

Type	X mm [in]	Y mm [in]	Z mm [in]
CAR 155 DT 414 120R	200 [7.8]	200 [7.8]	200 [7.8]
CAR 200 DT 415 80R	200 [7.8]	200 [7.8]	200 [7.8]

20 Mechanical installation

(JBR-04) CBR-V 210 DT 415 40R

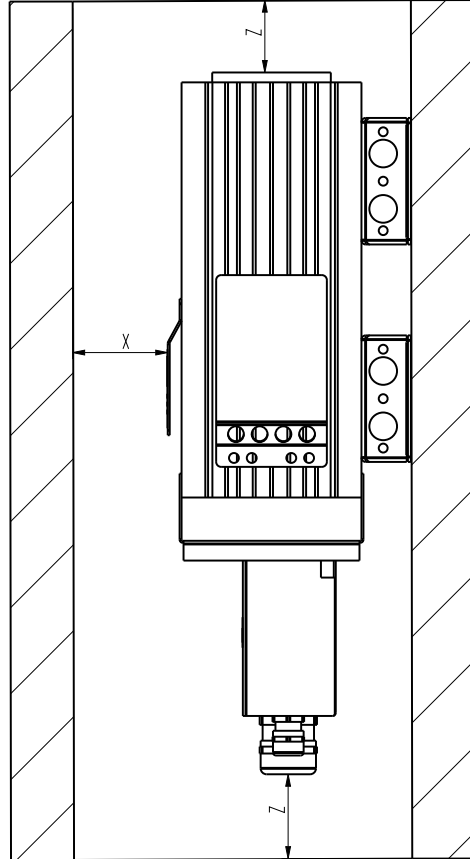
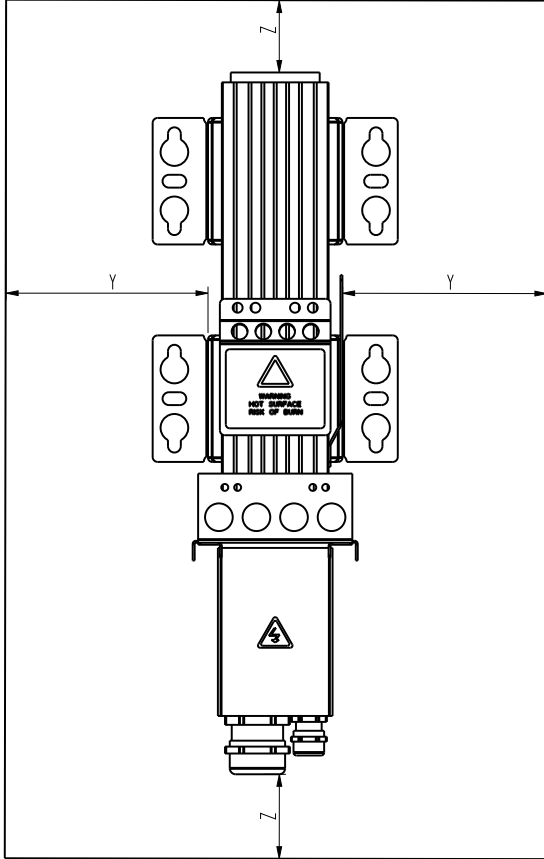

Type	X mm [in]	Y mm [in]	Z mm [in]
CBR-V 210 DT 415 40R	200 [7.8]	200 [7.8]	200 [7.8]

5

Electrical installation

Measuring the insulation resistance of the brake resistor circuit



▲WARNING Obey the safety instructions of the drive. If you ignore them, injury or death, or damage to the equipment can occur. If you are not a qualified electrical professional, do not do electrical installation, commissioning or maintenance work.

1. Stop the drive and do the steps in [Electrical safety precautions \(page 8\)](#) before you start the work.
 2. Make sure that the resistor cable is connected to the resistor and disconnected from the drive output terminals.
 3. At the drive end, connect the R+ and R- conductors of the resistor cable together. Measure the insulation resistance between the conductors and the PE conductor with a measuring voltage of 1000 V DC. The insulation resistance must be more than 1 Mohm.
-

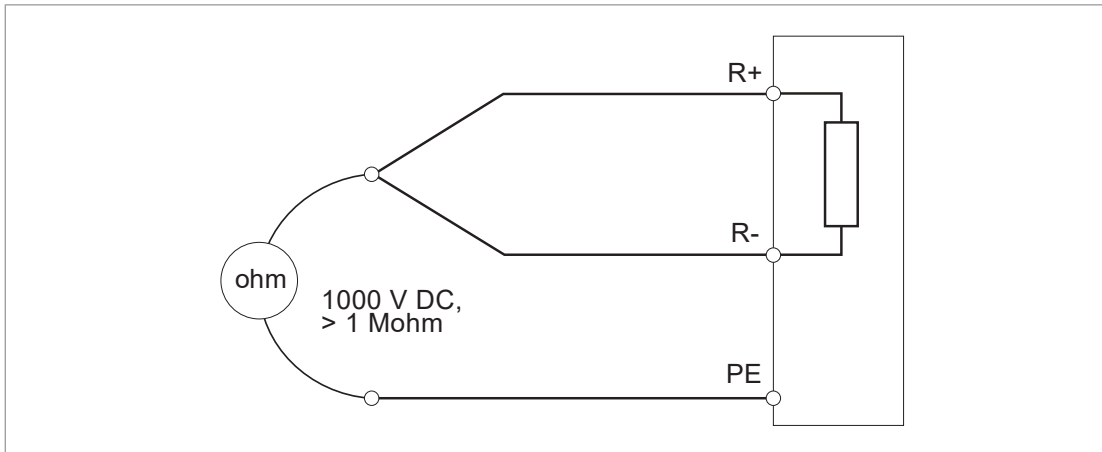

Protecting the system in brake circuit fault situations

■ Protecting the system in cable and brake resistor short-circuit situations

The drive input fuses also protect the resistor cable when it is identical to the input power cable.

■ Protecting the system against thermal overload

The drive has a brake thermal model that protects the brake resistor against overload. ABB recommends that you enable the thermal model at start up.

ABB recommends that you use a main contactor with the drive for safety reasons even when you have enabled the resistor thermal model. Connect the contactor so that it opens if the resistor overheats. This is essential for safety, since the drive will not otherwise be able to interrupt the main supply if the chopper conducts in a fault situation. The figure shows an example connection diagram. ABB recommends that you use resistors equipped with a thermal switch (1) in the resistor assembly. The switch indicates overtemperature.

ABB recommends that you connect the thermal switch to a digital input of the drive, and configure the input to cause a fault trip at resistor overtemperature indication.

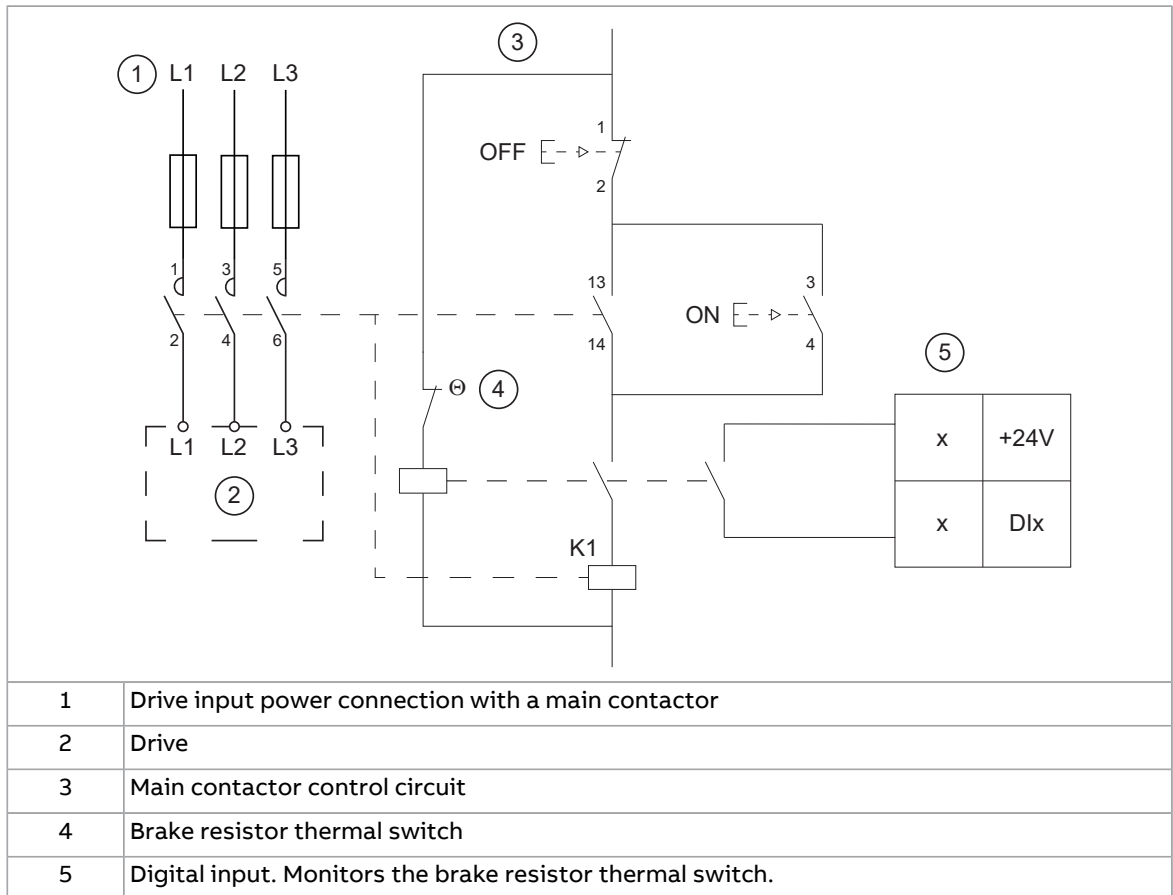

Protecting the brake resistor cable against short-circuits

The input fuses will also protect the brake resistor cable when it is identical with the input cable.

Connection procedure

Connect the resistor cables to the R+ and R- terminals of the drive. If a shielded three-conductor cable is used, cut the third conductor and ground the twisted shield of the cable (protective earth conductor of the resistor assembly) at both ends.

Wire the thermal switch to a digital input on the drive control unit.

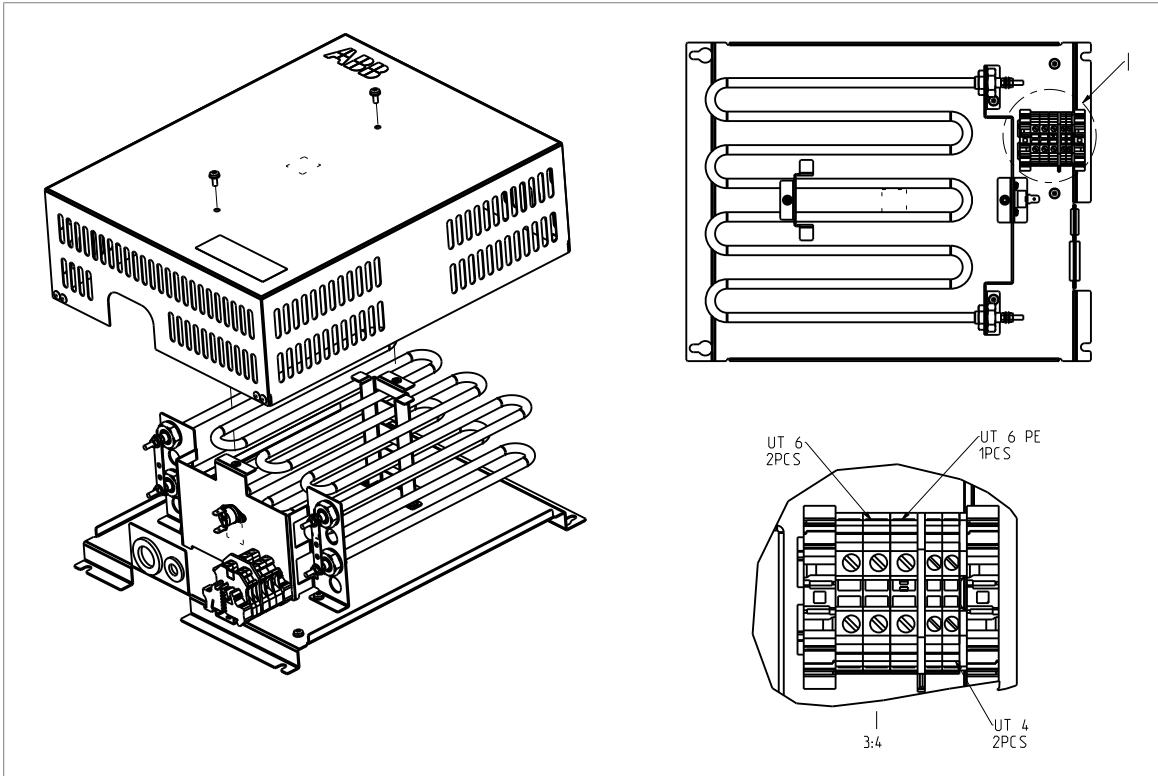



Start-up



WARNING Make sure that there is sufficient ventilation. New brake resistors can have a protective grease coating. When the resistor warms up for the first time, the grease burns off and can cause some smoke.

For brake resistor related parameter settings, refer to the drive hardware and firmware manuals.

NOTICE If you disable the brake chopper by parameter, also disconnect the brake resistor cable from the drive. Otherwise, there is a risk of resistor overheating and damage.



Dimension drawings

Contents of this chapter

This chapter shows the dimension drawings of SACE, SAFUR and JBR brake resistors.

Note: The dimensions are given in millimeters and [inches].

SACE resistors

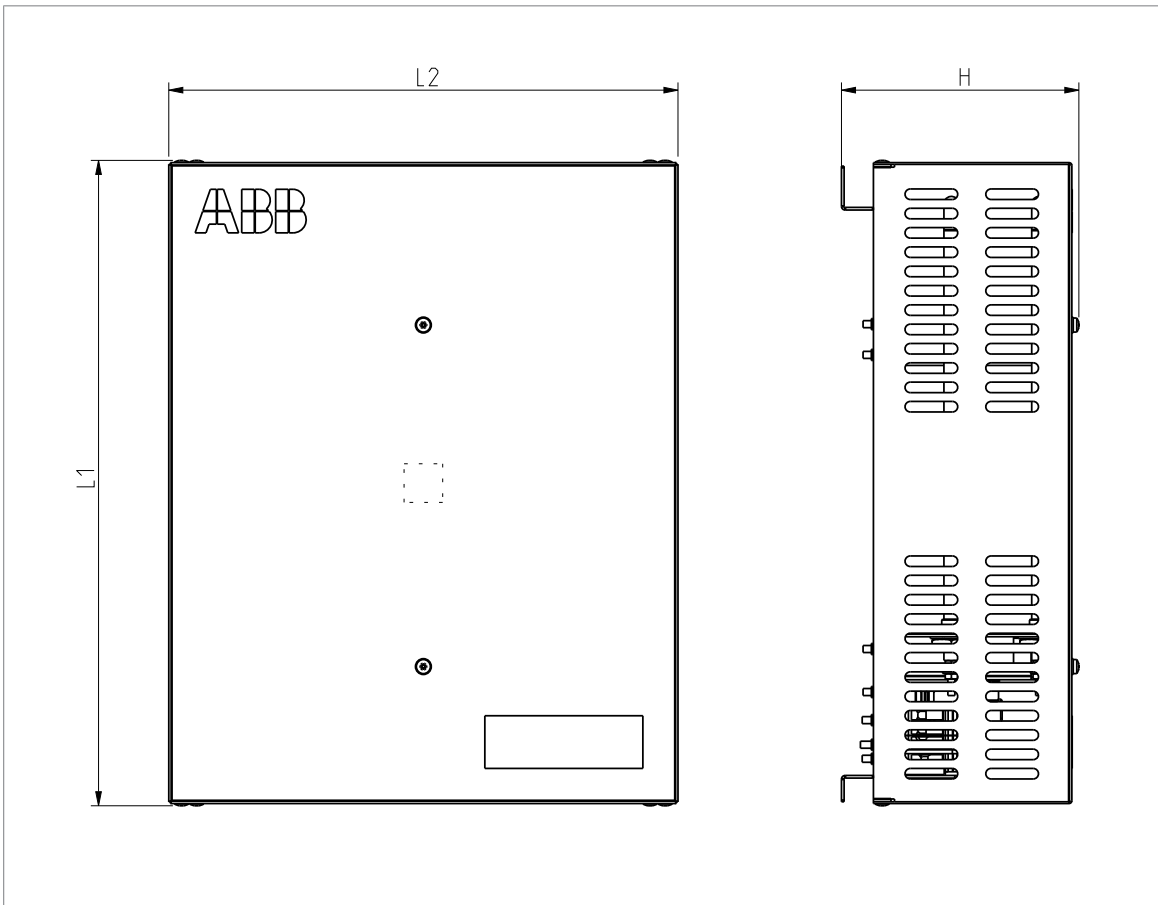

Type	L1 mm [in]	L2 mm [in]	H mm [in]	Weight kg [lbs]
SACE 08 RE 44	367.5 [14.47]	290 [11.42]	135 [5.32]	5.25 [11.6]
SACE 15 RE 13	367.5 [14.47]	290 [11.42]	135 [5.32]	6.35 [14.0]
SACE 15 RE 22	367.5 [14.47]	290 [11.42]	135 [5.32]	6.35 [14.0]

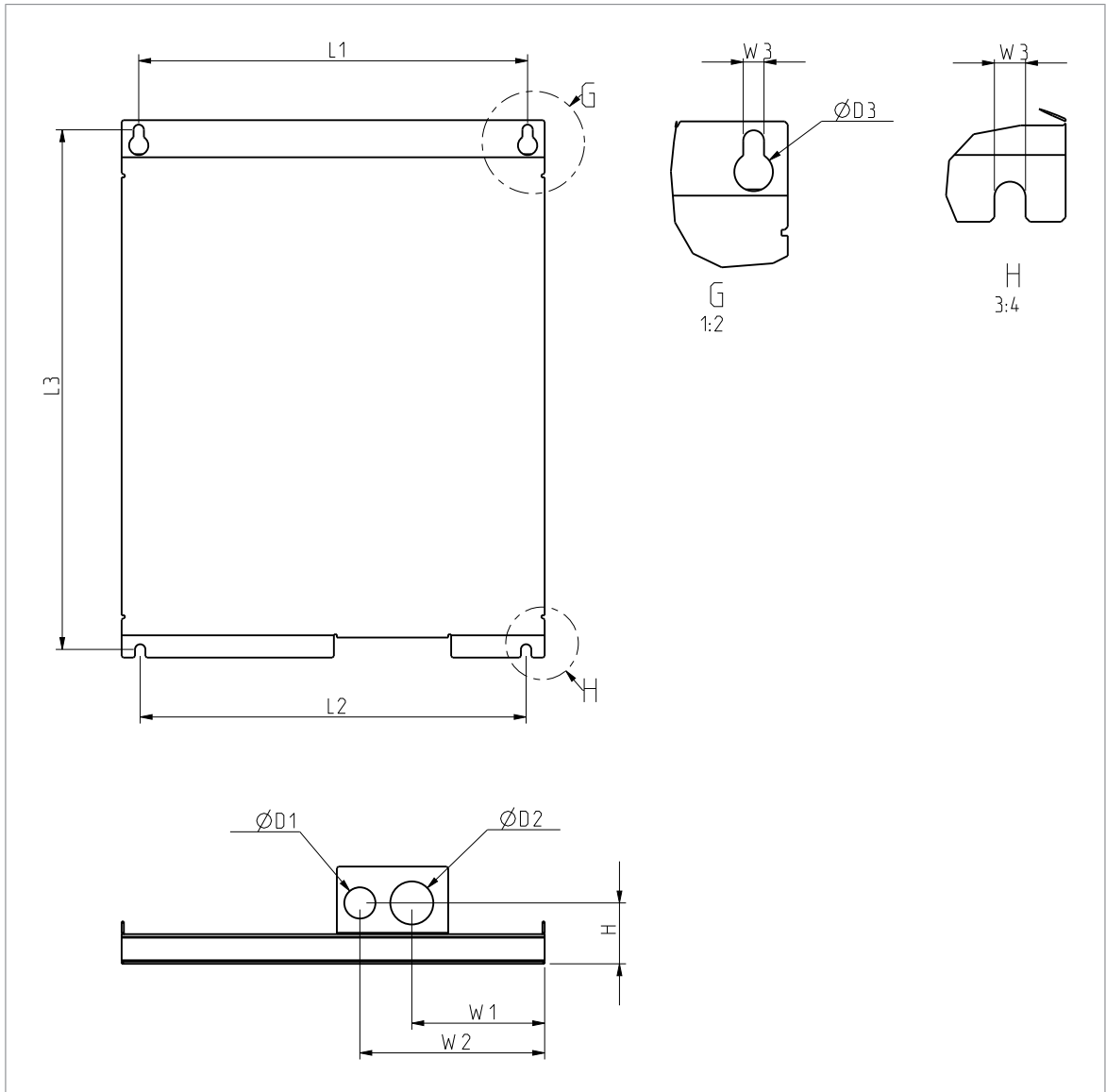

Type	L1 mm [in]	L2 mm [in]	L3 mm [in]	W1 mm [in]	W2 mm [in]	D1 mm [in]	D2 mm [in]	D3 mm [in]	W3 mm [in]	H mm [in]
SACE 08 RE 44	262 [10.31]	260 [10.24]	350 [13.78]	89.8 [3.52]	124.5 [4.90]	21 [0.83]	29 [1.14]	13 [0.51]	7 [0.28]	41 [1.61]
SACE 15 RE 13	262 [10.31]	260 [10.24]	350 [13.78]	89.8 [3.52]	124.5 [4.90]	21 [0.83]	29 [1.14]	13 [0.51]	7 [0.28]	41 [1.61]
SACE 15 RE 22	262 [10.31]	260 [10.24]	350 [13.78]	89.8 [3.52]	124.5 [4.90]	21 [0.83]	29 [1.14]	13 [0.51]	7 [0.28]	41 [1.61]

SAFUR resistors

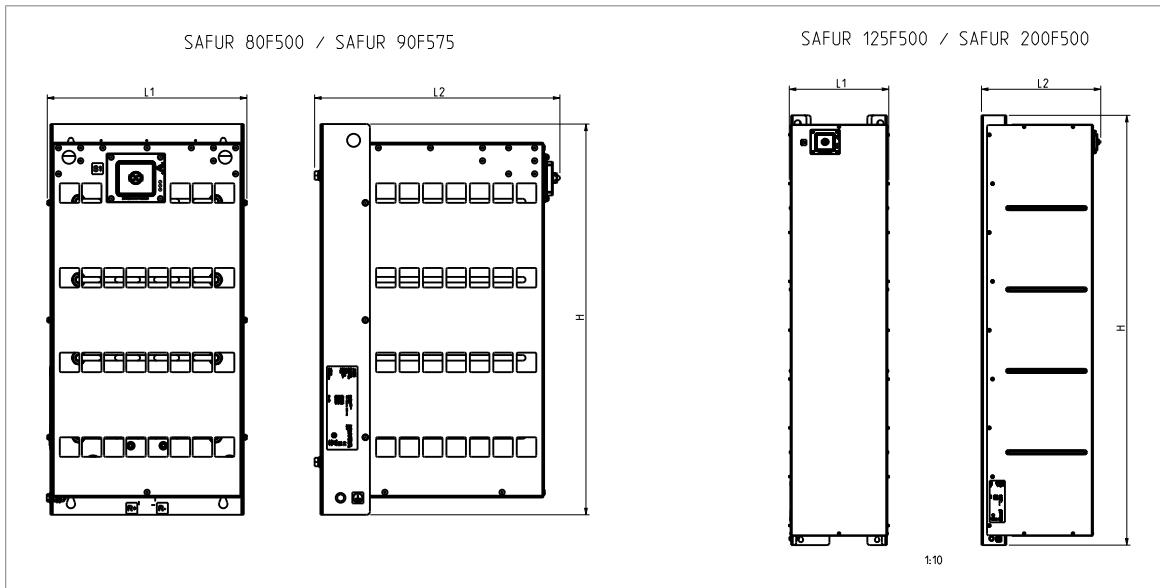

Type	L1 mm [in]	L2 mm [in]	H mm [in]	Weight kg [lbs]
SAFUR 80 F500 SAFUR 90 F575	306.5 [12.07]	376.7 [14.83]	600 [23.62]	16.33 [35.99]
SAFUR 125 F500 SAFUR 200 F500	305.5 [12.03]	366.4 [14.42]	1320 [51.97]	39.21 [86.44]

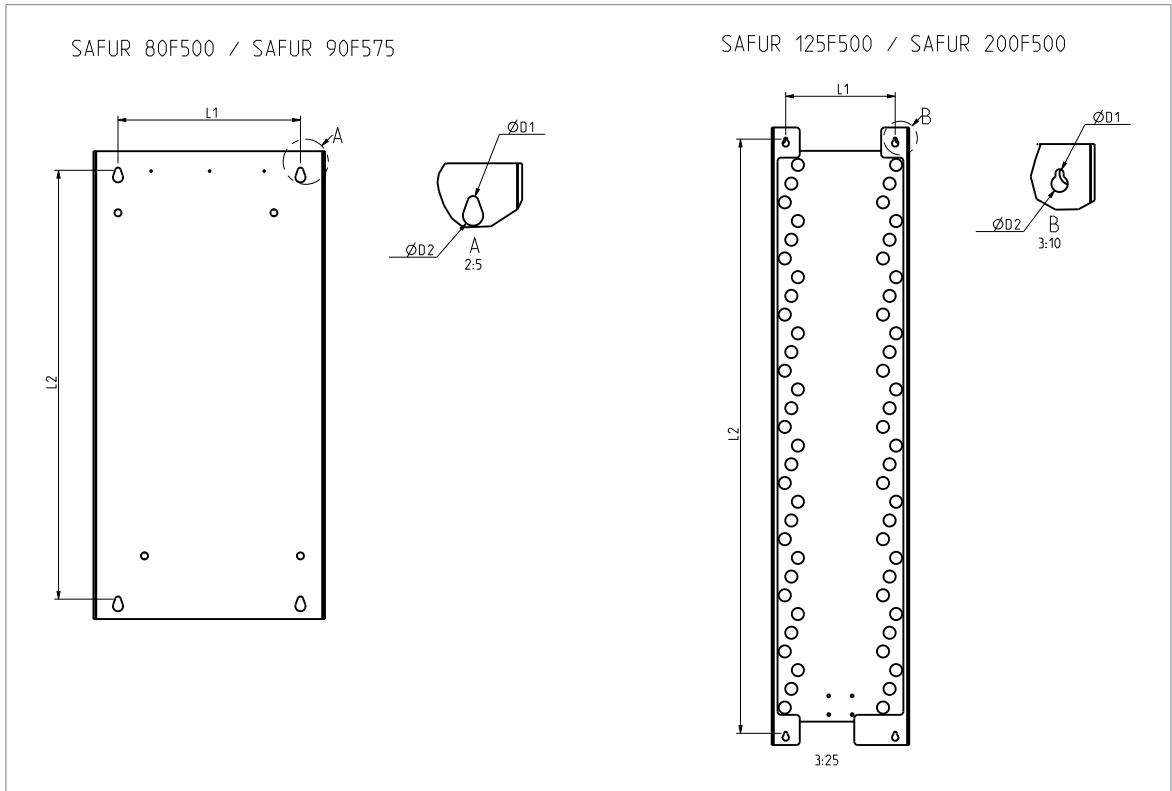

Type	L1 mm [in]	L2 mm [in]	D1 mm [in]	D2 mm [in]
SAFUR 80F500 SAFUR 90F575	234 [9.21]	550 [21.65]	7 [0.28]	13 [0.51]
SAFUR 125F500 SAFUR 200F575	234 [9.21]	1270 [50.00]	7 [0.28]	14 [0.55]

JBR resistors

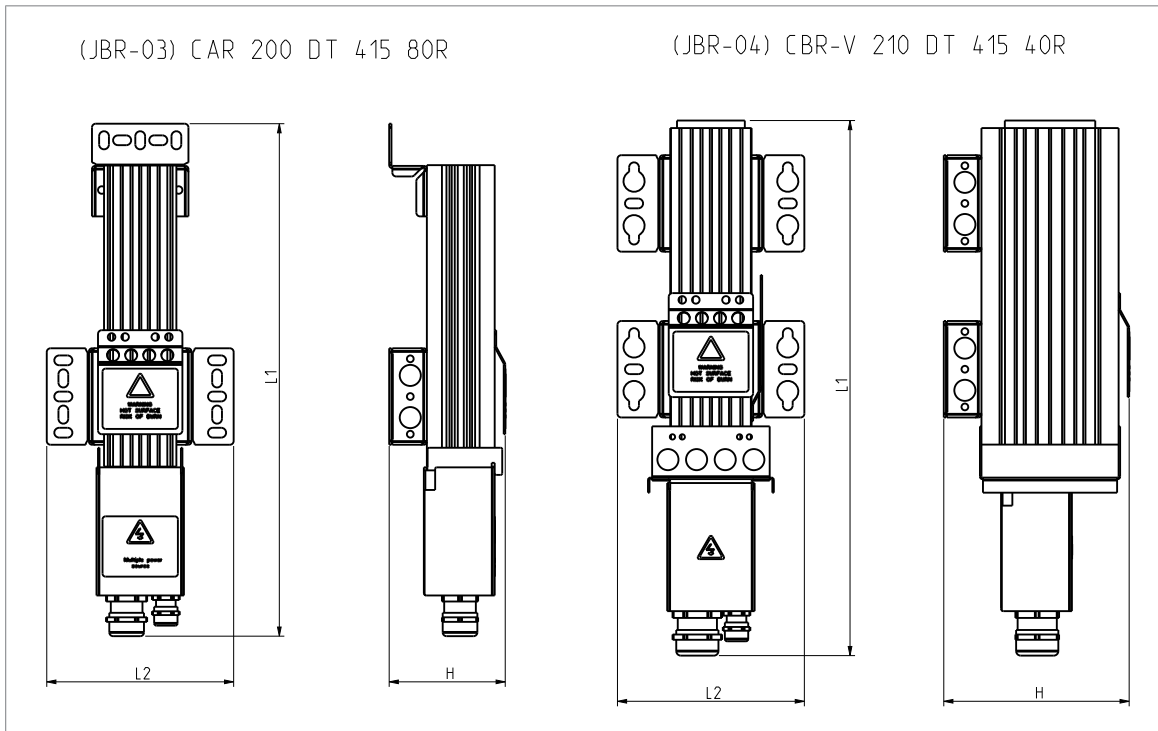

Type	L1 mm [in]	L2 mm [in]	H mm [in]	Weight kg [lbs]
CAR 155 DT 414 120R	295 [11.61]	124 [4.88]	77 [3.03]	0.93 [2.05]
CAR 200 DT 415 80R	340 [13.39]	124 [4.88]	77 [3.03]	1.06 [2.34]
CBR-V 210 DT 415 40R	355 [13.98]	124 [4.88]	123 [4.84]	2.16 [4.76]

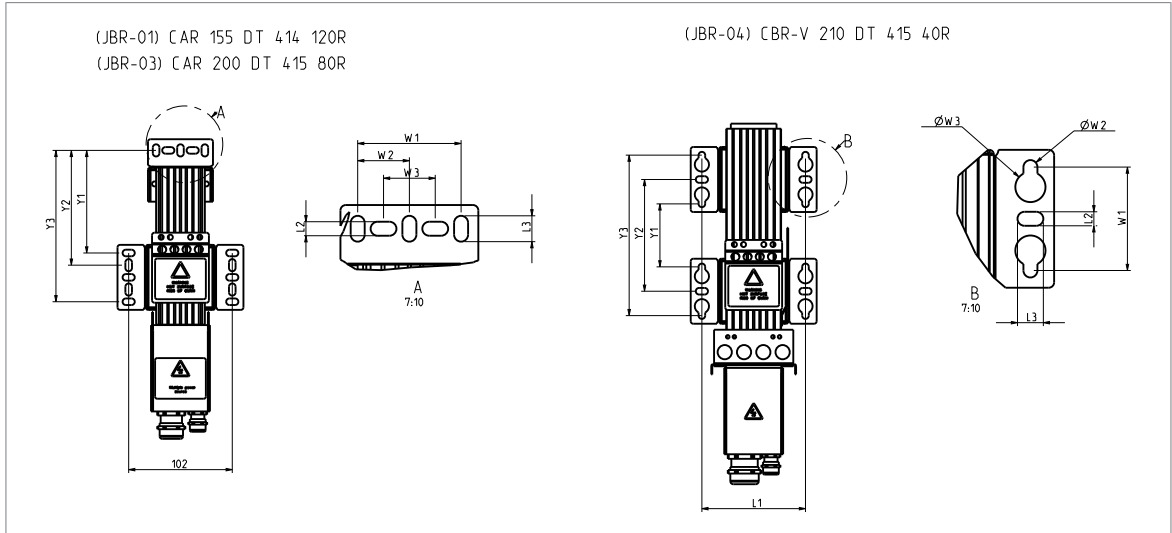

Type	L1 mm [in]	L2 mm [in]	L3 mm [in]	W1 mm [in]	W2 mm [in]	W3 mm [in]	Y1 mm [in]	Y2 mm [in]	Y3 mm [in]
CAR 155 DT 414 120R CAR 200 DT 415 80R	102 [4.02]	6.5 [0.26]	12 [0.47]	48 [1.89]	24 [0.94]	24 [0.94]	101 [3.98]	113 [4.45]	149 [5.87]
CBR-V 210 DT 415 40R	102 [4.02]	6.5 [0.26]	12 [0.47]	48 [1.89]	6.5 [0.26]	14 [0.55]	62 [2.44]	110 [4.33]	158 [6.22]



Technical data

SACE resistors

Type	P _{peak} (kW)	P _{Rcont} (kW)	R (ohm)	E _R (kJ)	Terminal connection
SACE 08 RE 44	15	1.2	44	210	Main terminals max. 6 mm ² Thermal switch terminals max 4 mm ² Cable length max. 10 m
SACE 15 RE 22	28	2	22	420	
SACE 15 RE 13	29	2	13	435	

SAFUR resistors

Type	P _{peak} (kW)	P _{Rcont} (kW)	R (ohm)	E _R (kJ)	Terminal connection
SAFUR 80F500/K160	120	6	6.0	2400	Main busbar connection with M6 cable lug Thermal switch flat male push on terminal 4.8 × 0.8 mm Cable length max. 10 m
SAFUR 90F575/K160	90	4.5	8.0	1800	
SAFUR 125F500/K160	180	9	4.0	3600	
SAFUR 180F460/K160	300	15	2.4	6000	
SAFUR 200F500/K160	270	13.5	2.7	5400	
SAFUR 210F575/K160	210	10.5	3.4	4200	
SAFUR 200F500/MK160	270	13.5	2.7	5400	

JBR resistors

Resistor		P _{Rcont} (W)	Pulse load (W) Temperature 40 °C, cycle 120 s				R (ohm)	E _R (kJ)	Terminal connection
ABB type	Manufacturer type		duty 1 s	duty 5 s	duty 10 s	duty 40 s			
JBR-01	CAR 155 DT 414	105	3750	1170	830	405	120	22	Main terminals max. 6 mm ² Thermal switch terminals max 4 mm ² Cable length max. 10 m
JBR-03	CAR 200 DT 415	135	7420	1910	1230	570	80	40	
JBR-04	CBR-V 210 DHT 415	360	10600	2800	1800	900	40	73	
JBR-05	CBR-V 330 DHT 415	570	30000	7100	4200	1700	20	77	
JBR-06	CBR-V 460 DHT 415	790	39400	12900	8000	2400	13	132	

P_{peak} Maximum continuous braking power allowed in 15 seconds

P_{Rcont} Continuous power heat dissipation of the brake resistor when the brake resistor is placed correctly

R Resistance of the brake resistor

E_R Short energy pulse that the brake resistor assembly withstands every 400 seconds

Degree of protection, thermal time constant and insulation resistance of the resistor

Resistor type	Degree of protection	Thermal time constant (s)	Insulation resistance (kV/min)
SACE	IP21	200	2
SAFUR	IP00	555	2
JBR	IP20	1000	3.5

9

Declarations of conformity



[Link to EU Declaration of conformity \(3AXD10002156065\)](#)

10

Circuit diagrams

SACE resistors

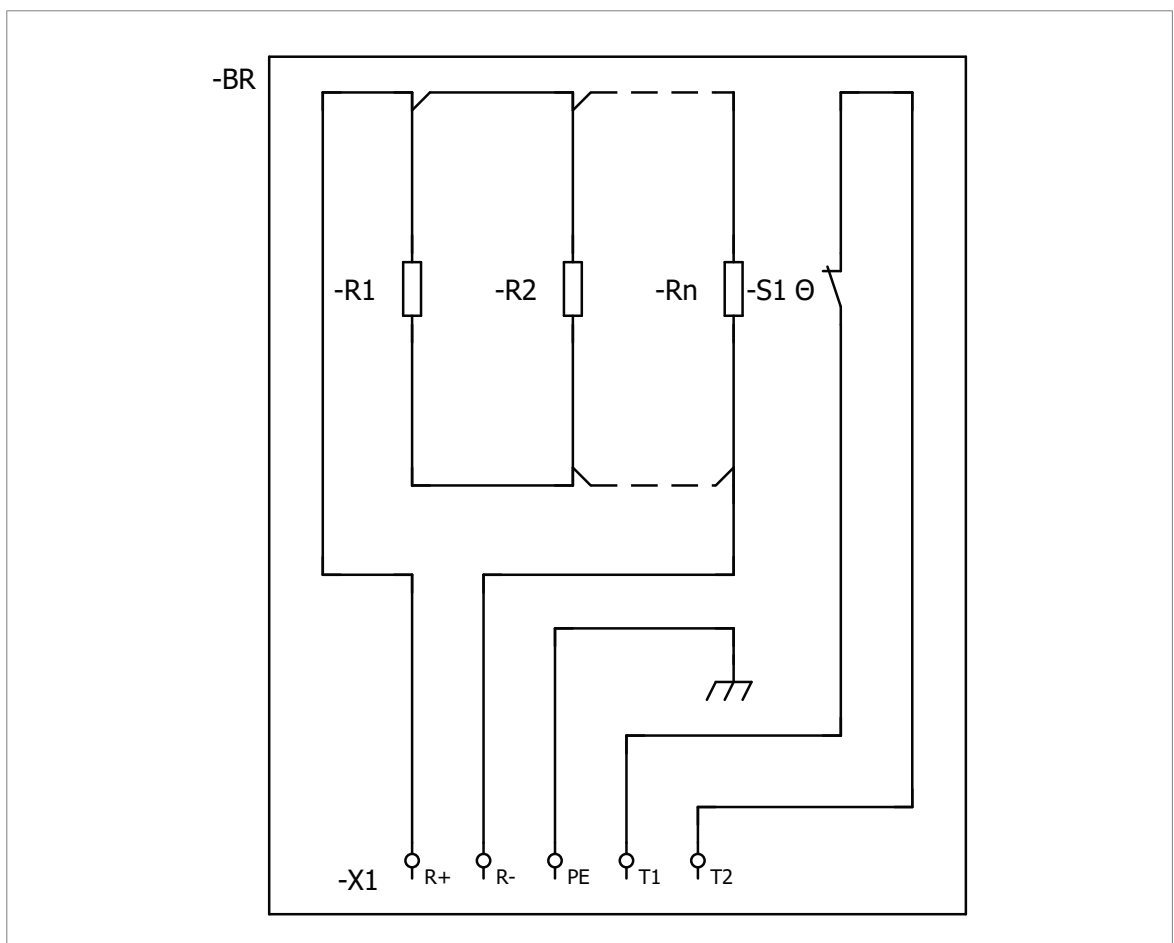

SAFUR resistors

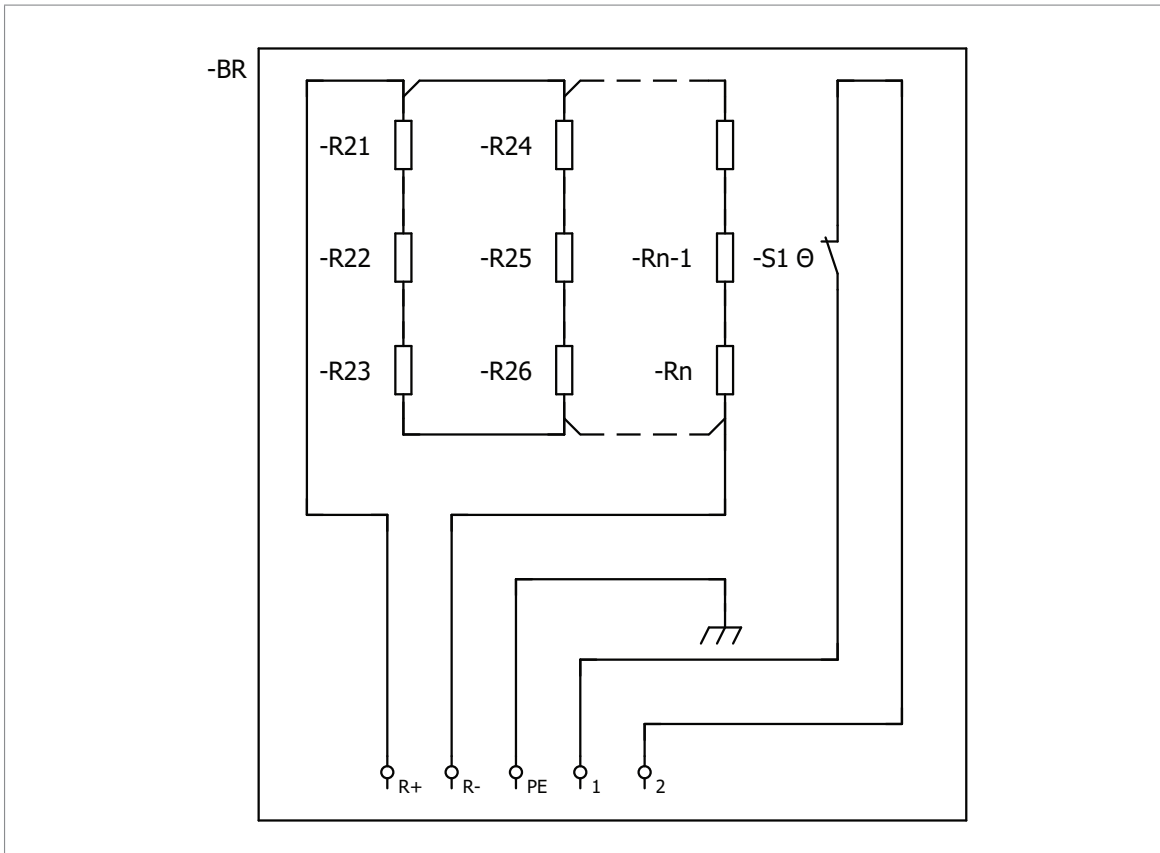

JBR resistors

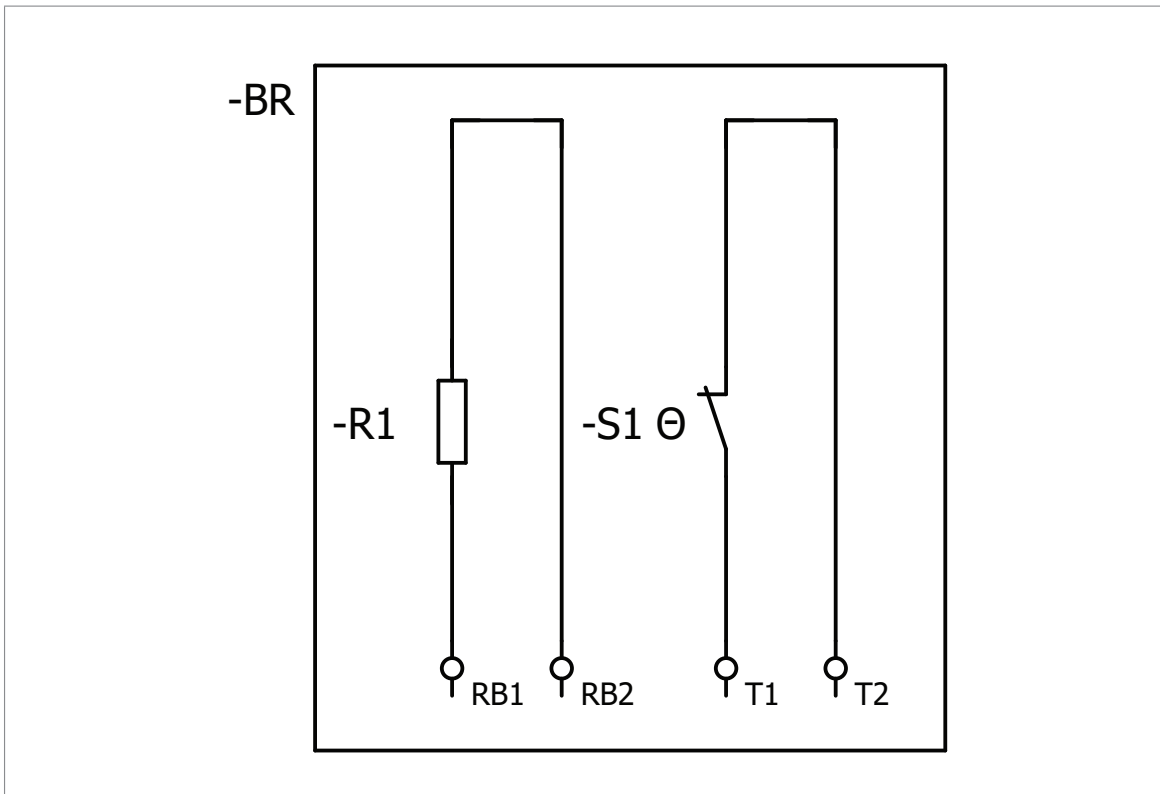



Further information

Product and service inquiries

Address any inquiries about the product to your local ABB representative, quoting the type designation and serial number of the unit in question. A listing of ABB sales, support and service contacts can be found by navigating to new.abb.com/contact-centers.

Product training

For information on ABB product training, navigate to new.abb.com/service/training.

Providing feedback on ABB manuals

Your comments on our manuals are welcome. Navigate to forms.abb.com/form-26567.

Document library on the Internet

You can find manuals and other product documents in PDF format on the Internet at www.abb.com/drives/documents.



www.abb.com/drives



3AXD50001283780B