

IEC 60870-5-103 Star Coupler RER 125

User's Guide



Contents

1. Introduction	4
1.1. RER 125	4
1.2. SFIB 103 option card	4
2. Safety information	5
3. Applications	6
4. Functions	8
4.1. General	8
5. Mechanical and electrical design	9
5.1. Block diagram	9
5.2. Option card slots	10
6. Interfaces	11
6.1. Fibre-optic connections	12
7. Mechanical design	13
8. Installation and configuration	14
8.1. Mechanical installation	14
8.1.1. Wall mounting	14
8.1.2. Panel mounting	15
8.1.3. Rack mounting	16
8.2. Installation of option cards	17
9. Technical data	18
10. Maintenance and service	20
10.1. Self-diagnosis	20
10.1.1. Power supply LEDs $U_{1_{aux}}$ and $U_{2_{aux}}$	20
10.1.2. Fault relays	20
10.2. Service and spare parts	20
11. Ordering information	21
12. Index	23

1 Introduction

1.1. RER 125

The RER 125 provides a fibre-optic star connection point for interconnection of devices using the IEC 60870-5-103 protocol.

As standard, the RER 125 unit includes:

- Optional single or double auxiliary power supply units with input voltage ranges 110...240 VAC/DC or 24...60 VDC
- Input/Output (I/O) card for power supply and fault relay connection
- 8 slots for option cards
- Communication speed 9600/19200 bps

1.2. SFIB 103 option card

SFIB103 option cards, which are placed into the RER 125, are used for interconnecting devices using the IEC 60870-5-103 protocol. These cards have to be ordered separately. Please refer to chapter 11 "Ordering information" on page 21.



The SFIB 103 option card includes 3 fibre-optic transceiver pairs for interconnection of bay level devices, for connection between two RER 125 units equipped with SFIB103 or between an RER 125 unit and higher level devices, e.g. MicroSCADA.

Channel 3 of the SFIB103 card can be configured as a master or a slave channel, while the other two serve only as slave channels. The channels are configured with DIP switches. A message entering the master channel is sent to the slave channels. A response from a slave channel is sent only to the master channel, and not echoed to the other slave channels, thus enabling only vertical communication. The default line idle state of a channel can be set with DIP switches. The state (light ON or light OFF) depends on the line idle state of the device connected to the SFIB103 card.

Note that in each RER 125 unit only one channel is configured for master operation.

For more information about the SFIB103 card, refer to the SFIB103 User's Guide, 1MRS751296-MUM.

2**Safety information**

	Electrostatic sensitive devices. ESD must be avoided during installation and while components remain detached.
	Dangerous voltages can occur on the connectors, even though the auxiliary voltage is disconnected.
	National and local electrical safety regulations must always be followed.
	Only a competent electrician is allowed to carry out the electrical installation.

3 Applications

A SFIB103 option card inside the RER 125 unit operates as a repeater between multiple connections in systems based on the IEC 60870-5-103 protocol. Channel 3 can be configured for master or slave operation, whereas the two other ones are slave channels. In each RER 125 unit only one channel should be configured for master operation. The configuration is done with DIP switches. A message entering the master channel is sent to all slave channels, but response messages from a slave are only sent to the master channel.

The picture below shows an example of a connection of the RER 125 unit.

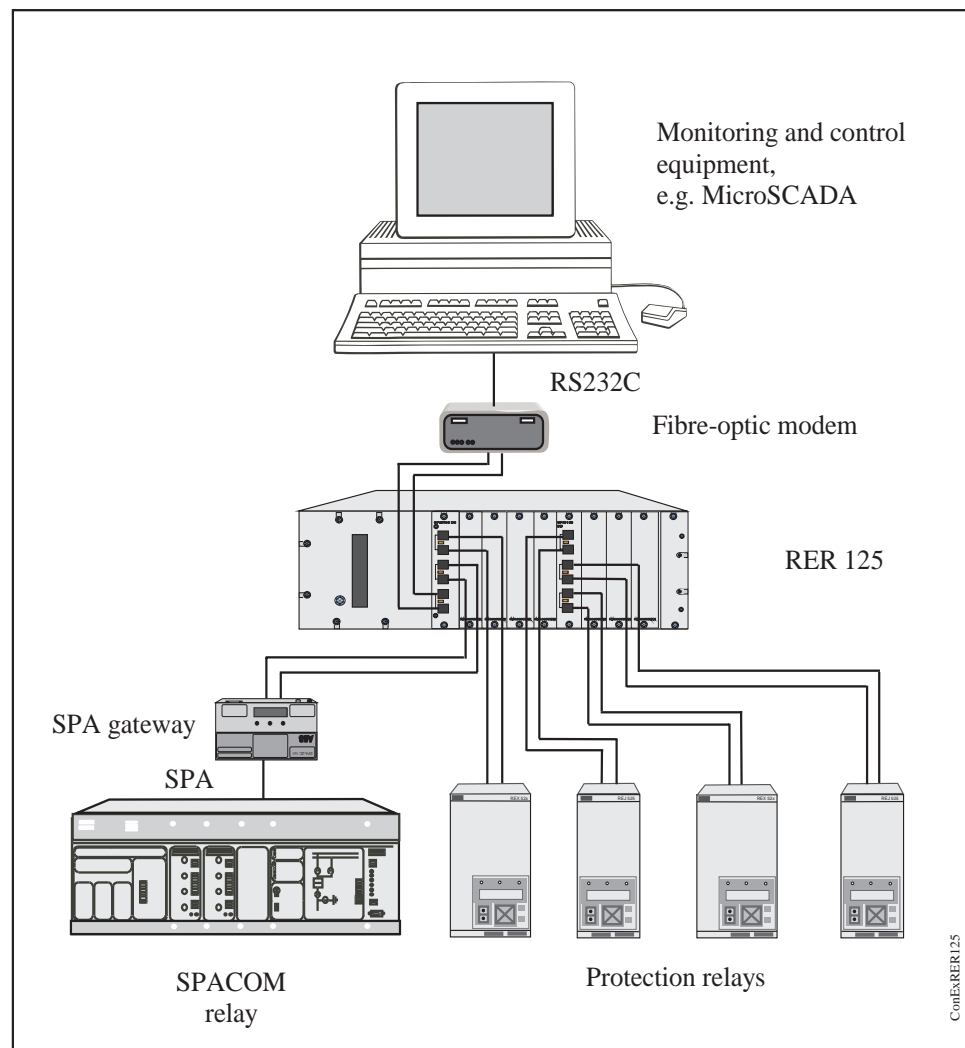

Fig. 3.-1 Example of a connection of the RER 125

The master channel of the RER 125 unit is typically connected to monitoring and control equipment via a fibre-optic modem, e.g. Westermo MA-62. The slave channels of the unit connect to slave devices either directly (devices using the IEC 60870-5-103 protocol) or via a SPA gateway.

User's Guide

Several RER 125 units may be used within any IEC 60870-5-103 network by connecting one main unit and many subordinate units. It is recommended that the RER 125 units are used on two levels at the maximum. The main RER 125 unit can be connected to higher level devices for monitoring, control, programming, etc.

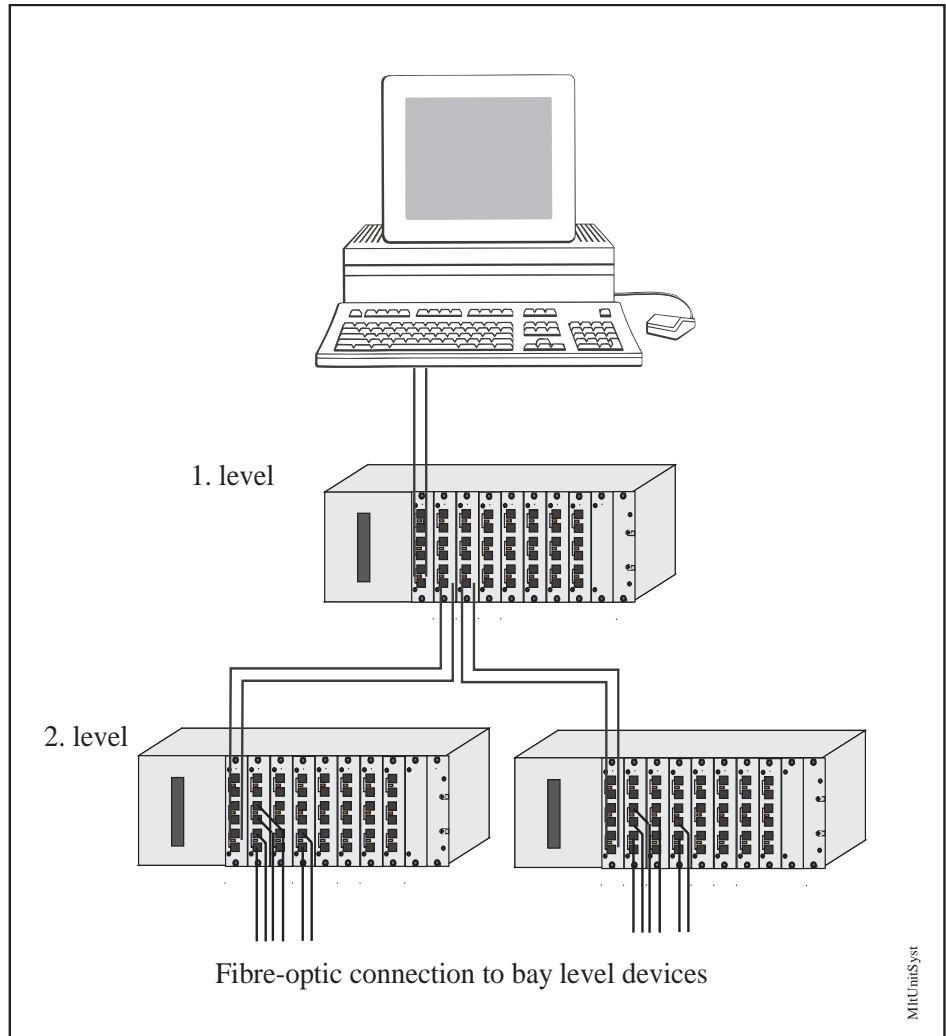

Fig. 3.-2 Large IEC 60870-5-103 network including several RER 125 units

4 Functions

4.1. General

The RER 125 unit functions as an interconnector of devices using the IEC 60870-5-103 protocol. It provides the power required by all the cards within the unit by integration of a single or double power supply. The supply voltage of the power supply card is either 110...240 VAC/DC or 24...60 VDC. These power supply cards can be used in any combination.

Further, the RER 125 unit contains an I/O module card. This module incorporates two fault relays used for diagnosing the condition of the power supply cards. The external power source required for the power supply cards is wired through this card. The fault relays can be connected to an alarm unit for monitoring the power supplies of the RER 125 unit.

The RER 125 unit provides the mother board connection for the option cards. The mother board contains two internal open collector buses and a power supply line, to which all eight option card slots are attached.

5 Mechanical and electrical design

5.1. Block diagram

The block diagram below shows the layout of the RER 125 unit, which consists of single or double power supplies, an I/O card, a mother board and slots for eight option cards.

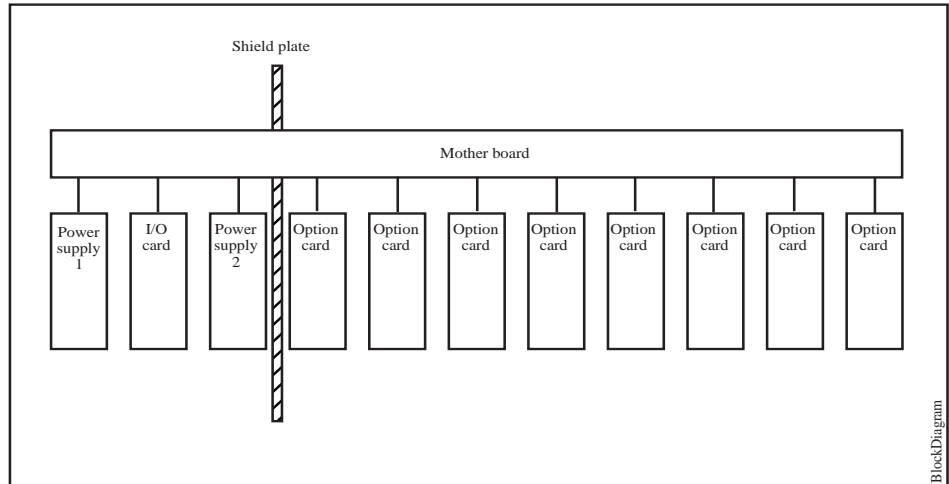

Fig. 5.1.-1 Block diagram of the RER 125 hardware

The power supply card(s) and the I/O card have fixed positions within the casing of the RER 125 unit. The cards are situated to the left in the casing, so that the first power supply ($U_{1_{aux}}$) is in the leftmost slot, the I/O card is in the middle slot and the second power supply card ($U_{2_{aux}}$), if any, is in the rightmost slot. Further, the case is divided into two sections by a shield plate.

There are two types of power supply cards available, SPGU 240 and SPGU 48.

Table 5.1.-1 SPGU 240

SPGU 240 A1	
Rated voltage	$U_N = 110/120/230/240 \text{ VAC}$ $U_N = 110/125/220 \text{ VDC}$
Operative voltage range	$U = 80...265 \text{ VAC}$

Table 5.1.-2 SPGU 48

SPGU 48 B2	
Rated voltage	$U_N = 24/48/60 \text{ VDC}$
Operative voltage range	$U = 18...80 \text{ VDC}$

Both the power supply modules are transformer connected, i.e. primary circuit is galvanically separated from secondary circuits with flyback type rectifiers. The primary circuit is protected by a fuse F1, 1 A (slow) in SPGU 240 A1 and 3 A (slow) in SPGU 48 B2. The fuses are located on the circuit board of the module.

The two power supply cards can be used in any combination. The power supply of the RER 125 unit is marked on the strip on the front plate of the device. Each power supply card is provided with a green LED that is lit when the card is energized, i.e. in use.

The I/O card has two fault relays and a 12-pin screw terminal. The terminal is used for the wiring of the power supply inputs and the fault relay outputs. See figure 5.1.-2

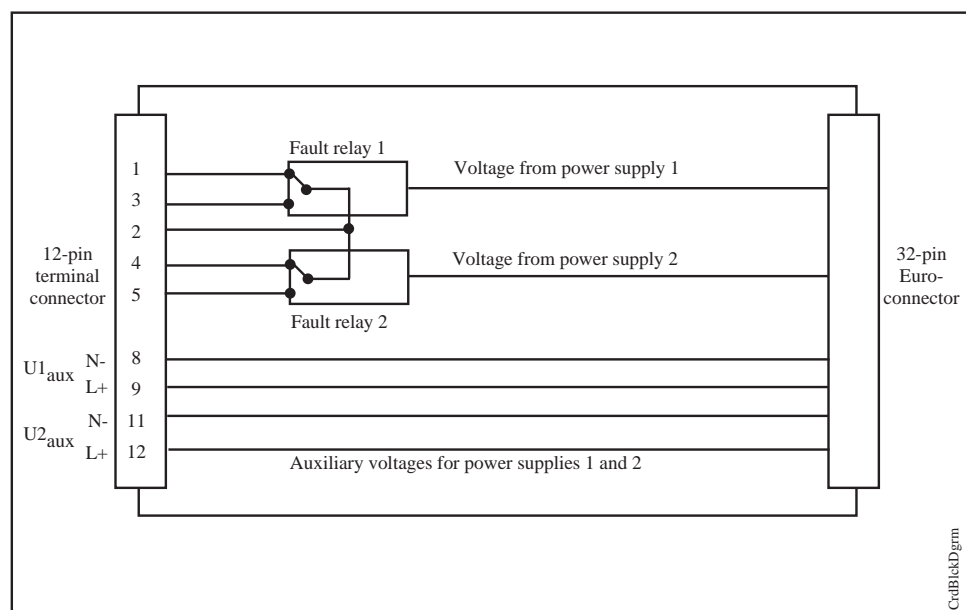

Fig. 5.1.-2 I/O card block diagram. The picture shows the normal state of the relays when the power supplies are energized and working.

5.2.

Option card slots

The mother board of the RER 125 unit contains eight option card connectors (64-pin E1 connectors) located to the right in the casing. As the slots are identical in construction, it is up to the user in what order to place the option cards in these slots.

6 Interfaces

The RER 125 unit has only one fixed interface, i.e. the screw terminal for power supplies and fault relays. Other interfaces available depend on the specific cards to which they are attached.

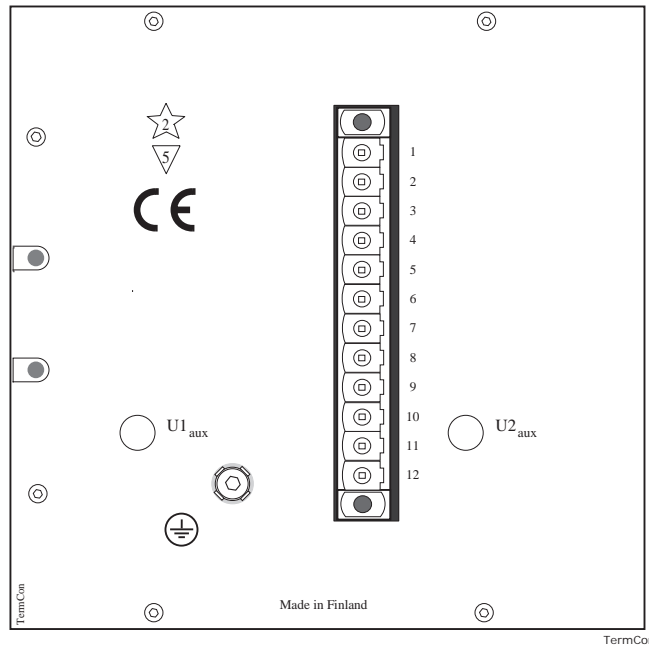

Fig. 6.-1 Screw terminal connections and power supply LEDs $U1_{aux}$ and $U2_{aux}$

Table 6.-1 Pin designations for the 12-pin screw terminal

Pin number	Designation
1	Fault relay output for auxiliary power 1. When power is applied, 1-2 is closed.
2	Common pin for fault relays 1 and 2.
3	Fault relay output for auxiliary power 1. When power is applied, 2-3 is open.
4	Fault relay output for auxiliary power 2. When power is applied, 2-4 is closed.
5	Fault relay output for auxiliary power 2. When power is applied, 2-5 is open.
6	Not used
7	Not used
8	$U1_{aux}$ N (-)
9	$U1_{aux}$ L (+)
10	Not used
11	$U2_{aux}$ N (-)
12	$U2_{aux}$ L (+)

User's Guide

The earth cable is connected to the earth pin located in the front plate covering the power supplies and the I/O card.



Before disconnecting the earth cable, turn off the auxiliary power supply and disconnect the screw terminal from the power supplies and the fault relays.

Table 6.-2 Power supply arrangements

Order code	U1 _{aux} Power type	U2 _{aux} Power type
RER125A-A	110...240 VAC SPGU 240 A1	-
RER125A-AA	110...240 VAC SPGU 240 A1	110...240 VAC SPGU 240 A1
RER125A-C	24...60 VDC SPGU 48 B2	-
RER125A-CC	24...60 VDC SPGU 48 B2	24...60 VDC SPGU 48 B2
RER125A-AC	110...240 VAC SPGU 240 A1	24...60 VDC SPGU 48 B2

6.1.

Fibre-optic connections

A fibre-optic transceiver consists of a transmitter and a receiver. It is possible to use glass core fibre-optic cables or plastic core fibre-optic cables. Depending on the cable type used, the connector can be an ST type or snap-in type of connector according to the following table.

Table 6.1.-1 Specification of the fibre core optic connections

	Glass fibre core	Plastic fibre core
Cable connector	ST connector	Snap-in connector
Cable diameter	62.5/125 µm	1 mm
Max. cable length	1000 m	20 m
Min. cable length	1 m	1 m
Typical fibre-optic cable attenuation	3.5 dB / 1000 m	0.15...0.23 dB / m
Wave length	820...900 nm	660 nm
Transmitted power	-13 dBm	-10 dBm
Receiver sensitivity	-24 dBm (HFBR-2412)	-20 dBm (HFBR-2521)



Read the cable manufacturer's specifications for used cable for more details.



Do not touch the fibre-optic transceiver and use always dust shields when transceivers are not in use.

7 Mechanical design

The RER 125 unit is built into an enclosure 3U in height and 3/4 of 19" in width, and the wall mounting bracket can be mounted in either side of the enclosure. See figure 7.-1.

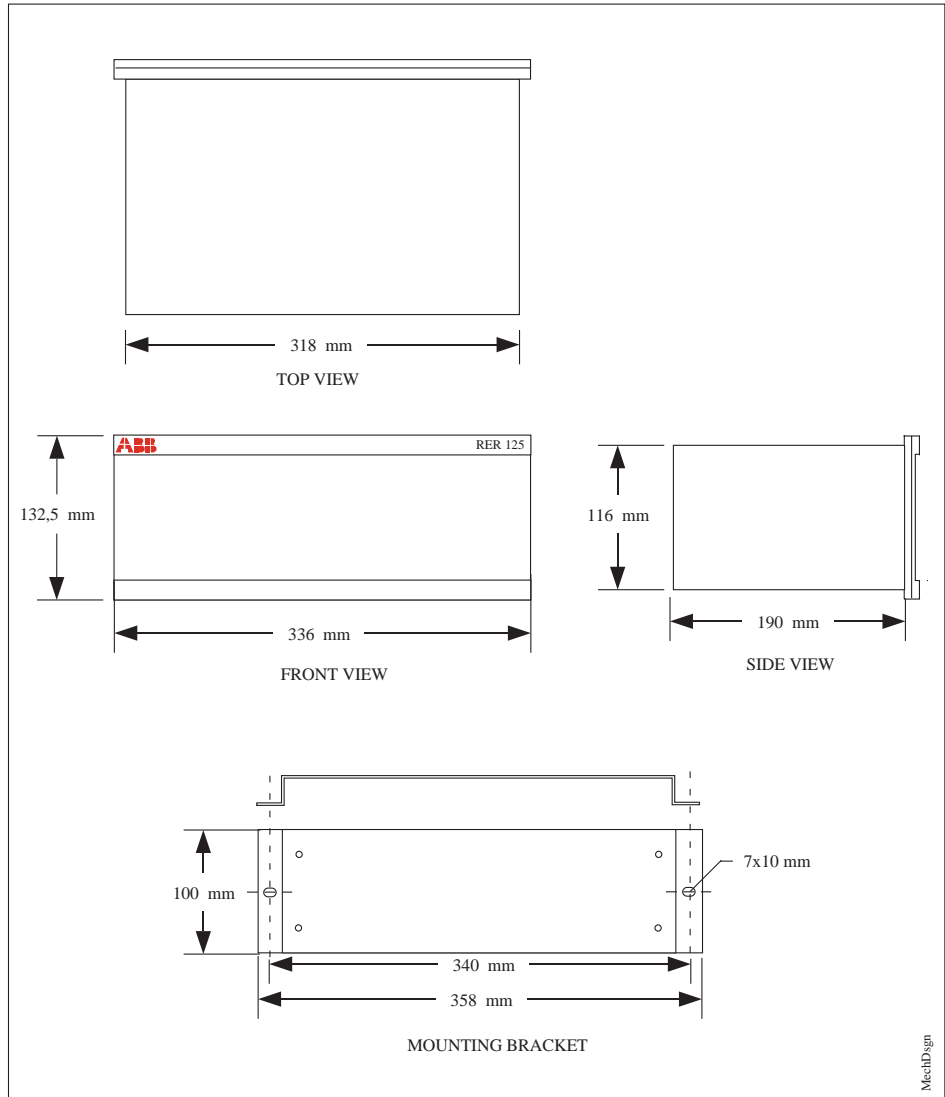

Fig. 7.-1 Mechanical drawing of RER 125 unit casing and wall mounting bracket

Each option card is covered by its own front plate attached to the circuit board. In addition, there is a plate covering the power supplies and the I/O card.

8 Installation and configuration

8.1. Mechanical installation

The RER 125 unit can be mounted on a wall, in a panel or in a 19" rack.

8.1.1. Wall mounting

At wall mounting, the wall mounting bracket included in the delivery must be attached to the screw holes on the side of the casing. The enclosure can be screwed to the wall in vertical or horizontal position.



When mounting the fibre-optic cables, follow the recommendations given by the manufacturer of the fibre-optic cable.

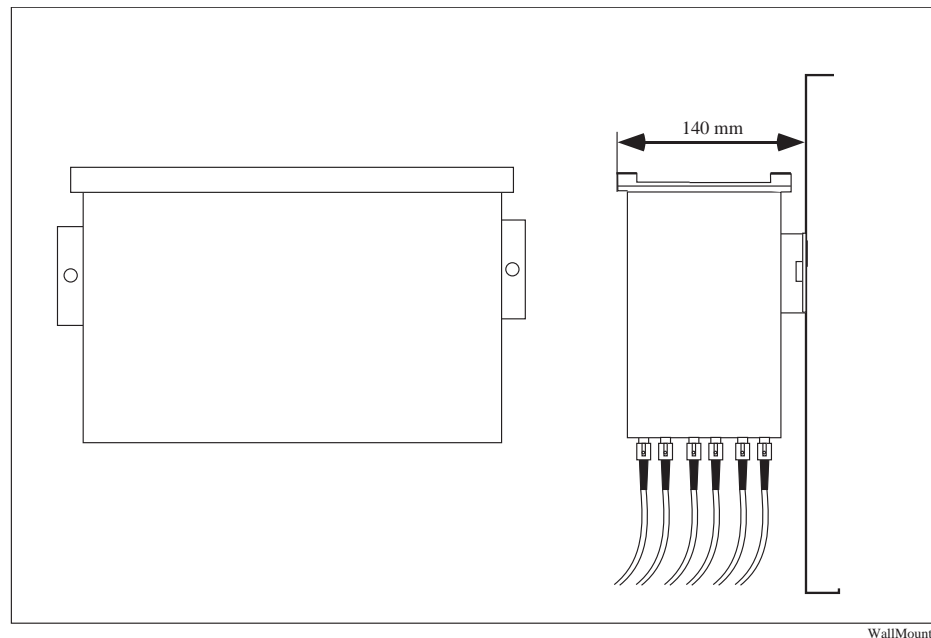
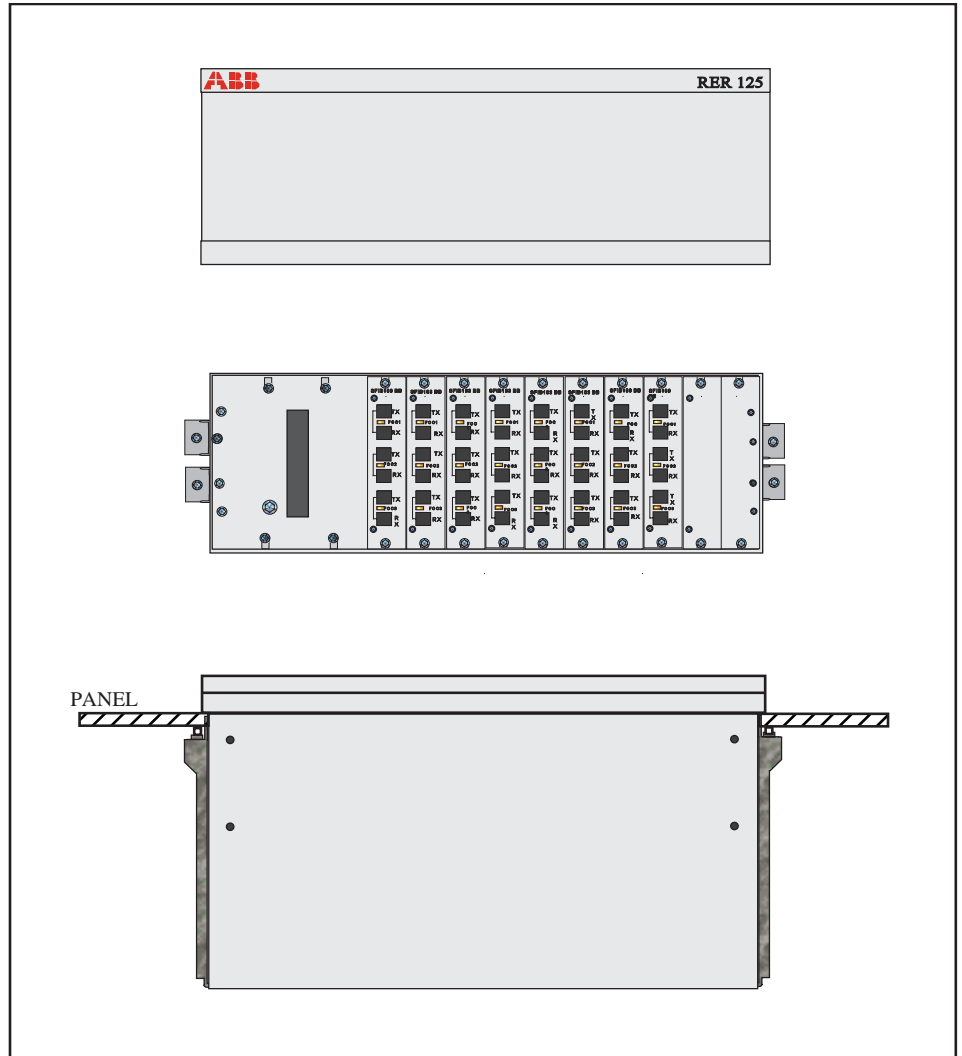

Fig. 8.1.1.-1 Wall mounting diagram

8.1.2. Panel mounting

A special mounting kit is required for mounting the unit in a panel. This panel mounting kit is delivered against separate order. For ordering information, see chapter 11 “Ordering information” on page 21.



PanelMount

Fig. 8.1.2.-1 Panel mounting diagram

8.1.3. Rack mounting

A special mounting kit is required for mounting the unit in a 19" rack, as shown in figure 8.1.3.-1 below. This rack mounting kit is delivered to separate order. For ordering information, see chapter 11 "Ordering information" on page 21.

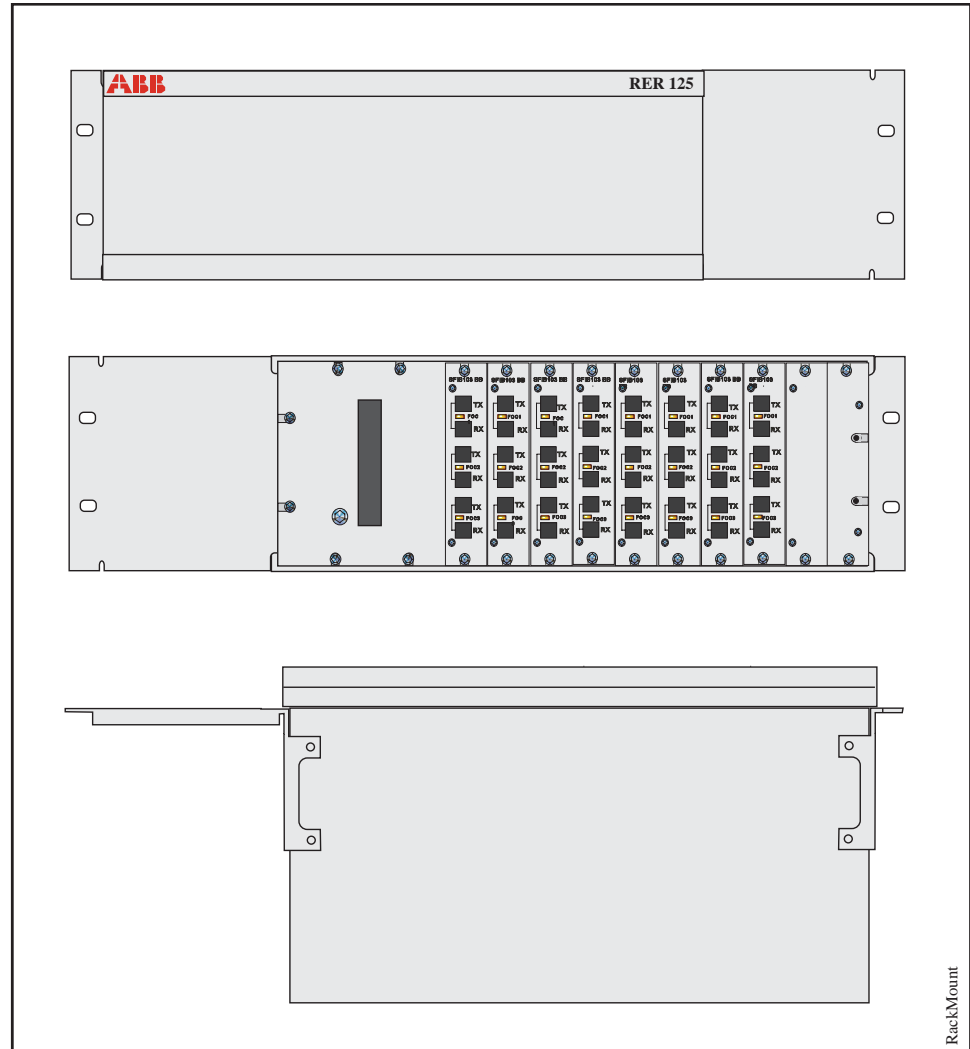

Fig. 8.1.3.-1 Rack mounting diagram

8.2. Installation of option cards

- Remove the strain screws in the blank plate or on the front plate of the option card.
- Lift off the blank plate or pull out the required option card of casing.
- Check that the DIP switches are in the right position.
- Push the option card into the unit until the front plate is flush with the enclosure.
- Secure the option card or blank plate to the case by tightening the strain screws.



Power must be set off during maintenance and service of the RER 125.

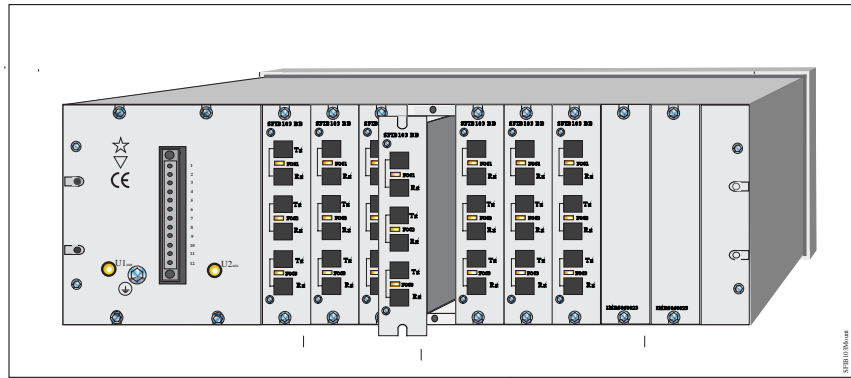

Fig. 8.2.-1 Mounting of SFIB103 option cards in the RER 125 unit

9

Technical data**Table 9.-1 Supply voltage**

Power supply module voltage range:	
SPGU 240 A1	
• Rated voltage U_N	110/120/230/240 VAC or 110/125/220 VDC
• Operative voltage range (U_{aux})	80...265 V ac/dc
SPGU 48 B2	
• Nominal voltage U_N	24/48/60Vdc
• Operative voltage range (U_{aux})	18...80 V dc
Power consumption with all option cards installed	< 20 W

Table 9.-2 Fault relays

Terminal numbers	Screw terminal/1-2,3-2,4-2,5-2 See Table 6.-1 on page 11
Nominal voltage U_N	250 Vac/dc
Continuous current carrying capacity	5 A
Make and carry for 0.5 s	10 A
Make and carry for 3 s	8 A
Breaking capacity for dc, when the control circuit time constant L/R < 40 ms, at 48/110/220 V dc control circuit voltage	1 A/ 0.25 A/ 0.15 A
Contact material	AgCdO ₂

Table 9.-3 Disturbance tests

High frequency interference test according to IEC 60255-22-1	
• common mode	2.5 kV, 1 MHz
• differential mode	1.0 kV, 1 MHz
Fast transient test according to IEC 61000-4-4 and IEC 60255-22-4, class IV	4 kV
Electrostatic discharge test according to IEC 61000-4-2 and IEC 60255-22-2, class III	
• contact discharge	6 kV
• air discharge	8 kV

Table 9.-4 Environmental conditions

Specified ambient service temperature range	-10...+55°C
Transport and storage temperature range	-40...+70°C

User's Guide

Table 9-5 Climatic environmental tests

Dry heat test according to IEC 60068-2-2	+55°C
Dry cold test according to IEC 60068-2-1	-10°C
Damp heat test according to IEC 60068-2-30	RH = 93%, 55°C, 6 cycles
Degree of protection by enclosure of the device case according to IEC 60529	IP 20

10 Maintenance and service

10.1. Self-diagnosis

10.1.1. Power supply LEDs $U1_{aux}$ and $U2_{aux}$

Under normal operating conditions the LED is lit when the power supply card is in operation. The power supply LEDs are presented in Figure 6.-1.

Fault relays

The fault relays are located on the I/O card. The purpose of the fault relays is to indicate a fault within the power supply. There is one relay for each power supply. Should a fault occur, then the relay changes state thus indicating which power supply has failed. The relays can be wired to external alarm or monitoring circuits via the 12-pin terminal on the I/O card. For more information, see chapter “Block diagram” on page 9.

10.2. Service and spare parts



Power must be set off during maintenance and service of the RER 125.

If a fault is found in the power supply or the option card of the RER 125 unit, the faulty part shall be replaced with a new one. Please, send the faulty part to the manufacturer. If the fault is not in the power supply or the option card, please contact the local vendor or order new RER 125A-__. For ordering information, see page 21.

User's Guide

Mounting

The brackets required for panel or rack (19") mounting must be ordered separately.

Note: The brackets are delivered in pairs.

Mounting set	Type designation
Panel mounting kit	1MRS050209
19" rack mounting kit	1MRS050201

Example

Example of ordering an RER 125 unit, with one 110...240 VAC power supply, including four SFIB103A-MM option cards and two SFIB103-BB option cards:

RER125A-A0 1 pc.
SFIB103A-MM 4 pcs
SFIB103A-BB 2 pcs

12**Index**

A	
Application	6
B	
Block diagram	9
C	
Climatic environmental tests	19
Configuration	14
D	
DIP switch	4, 6, 17
Disturbance tests	18
E	
Electrical design	9
Environmental conditions	18
F	
Fault relay	8, 10, 11, 18, 20
Fibre-optic connections	12
I	
Installation	14, 17
Interfaces	11
L	
LED	10, 11, 20
M	
Master channel	4, 6
Mechanical design	9, 13
O	
Ordering information	21
P	
Panel mounting	15, 22
Power supply	4, 8, 9, 10, 12, 18, 20, 21
R	
Rack mounting	16, 22
S	
Safety information	5
Self-diagnosis	20
Service	20

User's Guide

SFIB103 Option Card	4, 6, 17
Slave channel	4, 6
Spare parts	20
SPGU 240	9, 10, 12, 18, 21
SPGU 48	9, 10, 12, 18, 21
Supply voltage	18
T	
Technical data	18
Transceiver	4, 12, 21
W	
Wall mounting	13, 14, 21



ABB Oy

Distribution Automation

P.O. Box 699

FI-65101 Vaasa

FINLAND

Tel. +358 10 22 11

Fax. +358 10 224 1094

www.abb.com/substationautomation