

ABB MEASUREMENT & ANALYTICS | DATA SHEET

SensyMaster FMT230, FMT250

Thermal mass flowmeter



Measurement made easy

Precise and dynamic direct mass flow measurement of gas

Efficient top-quality thermal sensor elements

- Single-chip design on ceramic carrier material for top long-term stability
- Effective protective frames of the sensor elements with flow-forming characteristics for top repeat precision

Powerful electronic unit on a common ABB platform

- Quick Modbus communication via a RS485 interface
- 'Plug-and-play' electronic unit swap with SensorApplicationMemory
- Top precision with dynamic temperature compensation

ApplicationSelector

- Up to 8 configurable applications for top flexibility

Integrated diagnosis and device verification

- Low costs thanks to longer maintenance cycles
- Higher system availability with preventative maintenance
- Process security thanks to sensor element verification

Overview – models

Sensor

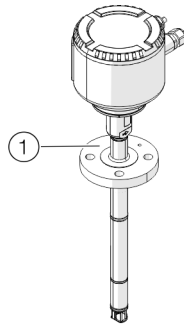

Figure 1: Sensor FMT230, FMT250 (example)

Model	FMT230	FMT250
Measuring media	Gas and gas mixtures with known composition, see table Available gas types on page 7	
Measuring accuracy for gases* Air	±1.2 % of Q_m in the range of 10 to 100 % of the standard measuring range; ±0.12 % of the Q_{maxDN} possible in the nominal diameter in the range of 0 to 10 % of the measuring range	±0.6 % of the measured value ± 0.05 % of the Q_{maxDN} possible in the nominal diameter
Other gases (with optional operating gas calibration)	—	±1.6 % of the measured value ±0.1 % of the Q_{maxDN} possible in the nominal diameter
Extended measuring range	Yes, optional (depending on the gas type, with limited measuring accuracy possibly)	Yes, optional (depending on the gas type, with limited measuring accuracy possibly)
Measuring medium temperature T_{medium}	Standard and explosion-proof design: –20 to 150 °C (–4 to 302 °F) Temperature information for high temperature**, low temperature and DVGW design, see Measured medium temperature on page 12.	Standard and explosion-proof design: –20 to 150 °C (–4 to 302 °F)
Ambient temperature $T_{ambient}$	Standard: –20 to 70 °C (–4 to 158 °F) Optional: –40 to 70 °C (–40 to 158 °F)	
Sensor connection ①	Flange DN 25 – PN 40, threaded connection DIN 11851, compression fitting	
Wetted materials	Stainless steel, ceramic sensor element	
Power supply	24 V DC, ±20 %	
IP rating	In accordance with EN 60529: IP 65 / IP 67	
NEMA rating	In accordance with NEMA 4X	
Communication	Modbus® RTU, RS485	
Outputs in serial production	Two passive digital outputs	
ApplicationSelector	Yes, up to 2 applications	Yes, up to 8 applications
Preconfigured applications	Yes, up to 2 applications	Yes, up to 4 applications
Freely configurable applications	No	Yes, up to 4 applications
Selectable nominal diameters	Yes	Yes
Selectable gas type	No	Yes
Filling function	No	Yes, optional
"VeriMass" diagnosis function	Yes, optional	Yes, optional
Approvals and certificates		
ATEX/IECEx/UKEX explosion protection	Zone 0, 1, 2, 21, 22	Zone 0, 1, 2, 21, 22
Explosion protection conforming to cFMusClass I Div. 1, Class I Div. 2, Zone 1, 2, 21		Class I Div. 1, Class I Div. 2, Zone 1, 2, 21
Additional approvals	Available on our website abb.com/flow or on request	

* The stated measuring accuracy only applies under the reference conditions in the stated standard measuring range.

** Not in connection with explosion-proof design.

... Overview – models

Pipe components (process connections)

FMT091 – Wafer type design

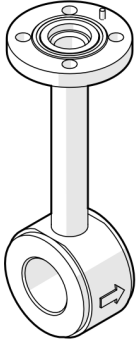

FMT094 – Weld-on adapter

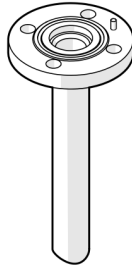

FMT094 – Weld-on adapter with clamp ring threading

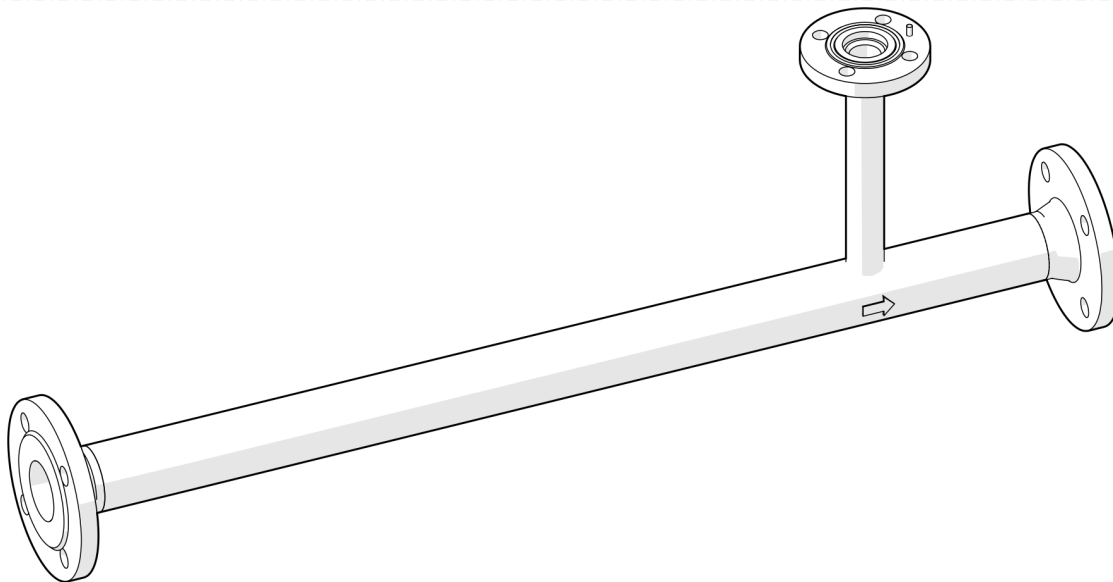

FMT092 – Partial measuring section

Figure 2: Pipe components (examples)

Pipe components

FMT091 – Wafer type design	In accordance with EN 1092-1: DN 40 to 200, PN 40 In accordance with ASME B16.5: 1½ to 8 in, CL 150 to 300
FMT092 – Partial measuring section	Flange in accordance with EN 1092-1: DN 25 to 100 (larger nominal diameters on request), PN 10 to 40 Flange in accordance with ASME B16.5: 1½ to 8 in, CL 150 to 300 Male thread DN 25 to 80, R1 to 3 in
FMT094 – Weld-on adapter	For rectangular ducts or pipe diameters \geq DN 80 (3 in.), PN 16 to 40
Options	With ball valve (order code SCA) or integrated hot tap fitting (order code SCB, SCC, SCD)
ATEX/IECEX/UKEX explosion protection	Zone 1, 2, 21, 22
Explosion protection conforming to cFMus	Can be used in Div. 1, Div. 2, Zone 1, 2, 21

Wetted materials for pipe components

Stainless steel, galvanized

Temperature data for pipe components

Measuring medium temperature T_{medium} Standard: -20 to 150 °C (-4 to 302 °F)

Ambient temperature T_{amb} for pipe Standard: -20 to 70 °C (-4 to 158 °F), optional: -40 to 70 °C (-40 to 158 °F)
components **without** ball valve or integrated hot tap fitting. Depending on the selected **ambient temperature range (TA3/TA9)** of the sensor and O-ring design.

Ambient temperature T_{amb} for pipe Standard: -20 to 70 °C (-4 to 158 °F)
components with ball valve or integrated hot tap fitting

(Sensor connection options: SCA, SCB, SCD)

... Overview – models

Device description

The SensyMaster FMT230, FMT250 works in accordance with the measuring principle of a hot-film anemometer. This measurement method allows for direct measurement of the gas mass flow.

Taking into account the standard density, the norm volume flow can be displayed without the need for additional pressure and temperature compensation.

The device is equipped with a Modbus® interface and two fast digital outputs that can be configured as pulse, frequency or binary outputs.

The SensyMaster FMT230, FMT250 is used in the process industry for the flow measurement of gases and gas mixtures.

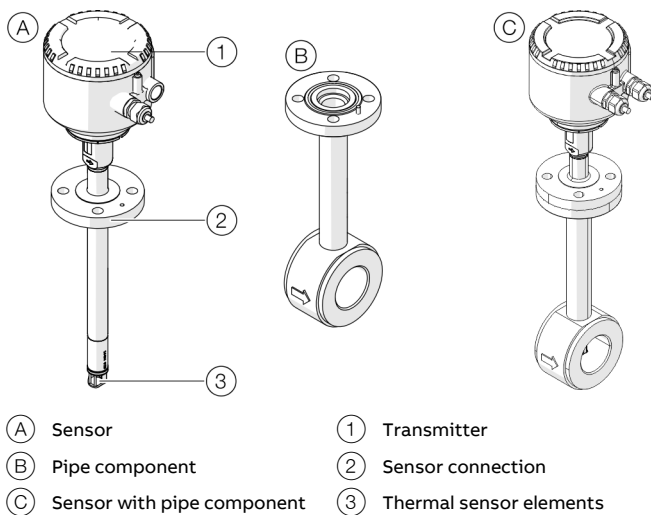

Figure 3: Sensor (example, wafer type design)

The SensyMaster FMT230, FMT250 is composed of the components sensor and pipe component (process connection).

The pipe component can be delivered in various designs. In addition, a weld-on adapter makes it possible to install the flowmeter sensor in rectangular ducts or pipelines with any diameter.

Measuring principle

Thermal flow metering procedures use different ways to evaluate the flow dependent cooling of a heated resistor as measuring signal.

In a hotfilm anemometer with constant temperature difference control, the heated platinum resistor is maintained at a constant overtemperature in relation to an unheated platinum sensor inside the gas flow.

The heating power required for maintaining the overtemperature depends directly on the flow rate and the material properties of the gas. With a known (and constant) gas composition the mass-flow can be determined by electronically evaluating the heater current / mass-flow curve without additional pressure and temperature compensation. Together with the standard density of the gas this results directly in the standard volume flow.

Considering the high measuring range dynamics up to 1:100, an accuracy smaller than 1 % of the measuring value is achieved.

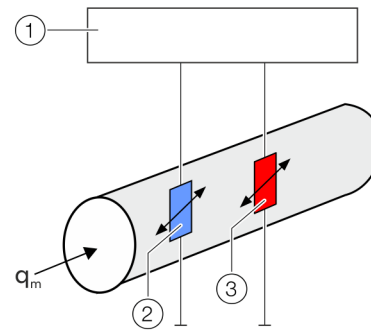

- | | |
|--|----------------------|
| (1) Transmitter | (3) Heating resistor |
| (2) Gas temperature measurement resistor | |

Figure 4: Measuring principle (simplified)

The transmitter has three signals available. In addition to the heating power, the temperatures of the measuring medium and the heater resistance are included herein, which can be used to compensate the temperature dependency of gas parameters.

By storing the gas data in the transmitter the optimal tailoring can be calculated and performed at any operating point.

Advantages of the SensyMaster measuring principle

- Through the provision of several primary and secondary signals, they can be displayed in parallel via the Modbus® interface. This saves a gas temperature measurement.
- Regulating the sensor element and adjusting the signal processing to the process becomes possible through the implementation of fully digital signal processing. Thus, an optimum measuring dynamic can always be achieved even under changing operating conditions.
- The SensyMaster measuring principle can offer an even larger measuring range.

Typical applications

- Gas volume measurement in the chemical industry and process technology
- Pressurized air balancing
- Gas burner controls
- Digester gas and activation air measurements in sewage plants
- Gas measurement in air separators
- Hydrogen measurements in the process

ApplicationSelector – integrated data bank for gases

The thermal mass flowmeter SensyMaster FMT230, FMT250 has an integrated gas data bank (see table **Available gas types** on page 7).

Two (FMTx30) or eight (FMTx50) different applications can be defined in total.

Up to two or four applications can also be factory-preconfigured on request.

The operator can define their own applications (only with FMTx50):

- For each application, the gas type can be chosen from a table, additionally gas mixtures of up to ten different gases can also be configured.
- For each application the pipeline diameter can be configured.
- For each application the parameters for the flow rate and temperature measurement can be configured.

Available gas types

Air	Ketene – CH ₂ CO
Nitrogen – N ₂	Diketene – C ₄ H ₄ O ₂
Oxygen – O ₂	Ethane – C ₂ H ₆
Methane – CH ₄	Ethanol – C ₂ H ₅ OH
Carbon dioxide – CO ₂	Ethylene – C ₂ H ₄
Hydrogen – H ₂	Formaldehyde – CH ₂ O
Biogas Type 1*	Helium – He
Propane – C ₃ H ₈	Hexane – C ₆ H ₁₄
Argon – Ar	Hydrogen sulphide – H ₂ S
Natural gas Type 1*	Methanol – CH ₃ OH
Acetone – C ₃ H ₆ O	Neon – Ne
Acetylene – C ₂ H ₂	Nitrogen oxide – NO
Ammonia – NH ₃	Ozone – O ₃
1.2-Butadiene – C ₄ H ₆	Pentane – C ₅ H ₁₂
1.3-Butadiene – C ₄ H ₆	Propadiene – C ₃ H ₄
Butane – C ₄ H ₁₀	Propylene – C ₃ H ₆
1 Butane – C ₄ H ₈	Water vapor – H ₂ O
Carbon monoxide – CO	

* In the case of natural gas and biogas, the exact composition must be provided.

Note

In the case of hydrogen and helium gas types as pure gas or as a component of a gas mixture with a concentration of over 10 %, an optional process gas calibration should always be additionally ordered.

That way, any possible additional measuring errors due to the special characteristics of gases are avoided.

Note

For measuring medium H₂ or He in nominal diameter DN 25 to DN 50 or 1 to 2 in please use pipe component design 2 (FMT092) with flow straightener.

... Overview – models

Diagnosis and self-monitoring

The thermal mass flowmeter SensyMaster FMT230, FMT250 also includes the internal monitoring of the transmitter and the sensor.

Amongst other things, the following functions and components are monitored:

- Monitoring of the power supply
- Limit value monitoring of the process values, temperature monitoring of the measuring medium
- Monitoring of the sensor element for line break and short-circuit
- Monitoring of the SensorApplicationMemory

Sensor element check 'VeriMass. (optional)

SensorCheck

VeriMass includes the SensorCheck, which verifies the integrity of the measuring elements and can notify of possible deposits on the measuring elements.

The SensorCheck relies on the comparison of fingerprints. The finger print includes values that are based on the temperature and heat conductivity of the measuring element. For instance, a fingerprint created during installation can be compared with a fingerprint created at a later point in time.

The SensorCheck must be started in the transmitter and always performed at zero flow under the same conditions. The comparison of values delivers information on possible damage or contamination of the measuring elements.

FillMass batch function

Only with FMT250

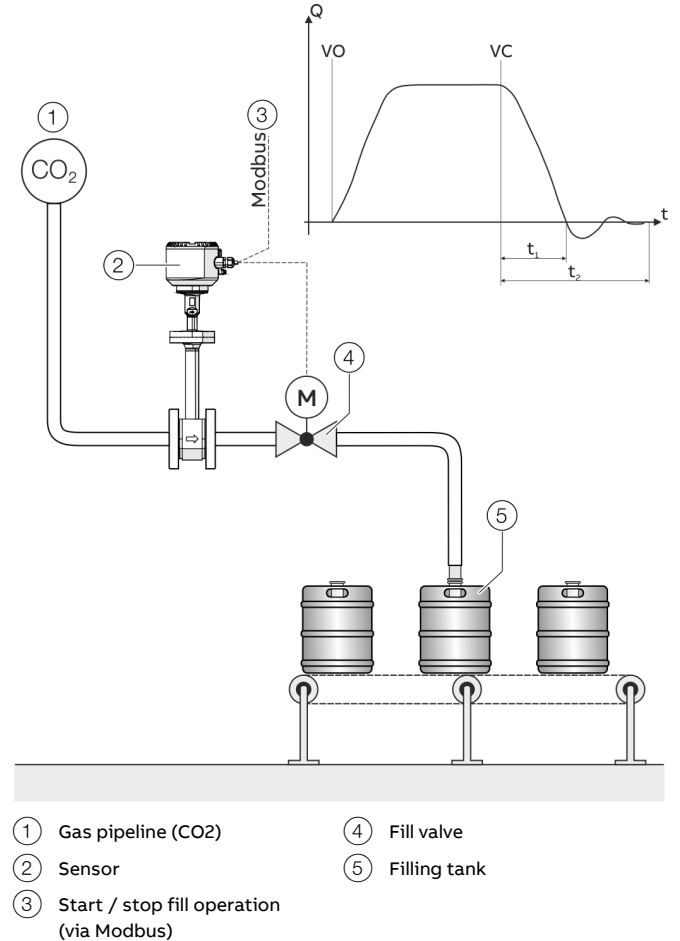

Figure 5: FillMass filling function (example CO₂ fill)

Diagram legend

VO	Valve open (filling started)
VC	Valve closed (fill quantity reached)
t ₁	Valve closing time
t ₂	Overrun time

The integrated FillMass fill function allows filling operations with filling times of > 3 s.

For this purpose, the filling quantity is given via an adjustable totalizer.

The Modbus interface is used to configure and control the fill function.

The valve is triggered via one of the digital outputs and closed again once the preset filling quantity is reached.

The transmitter measures the overrun quantity and calculates the overrun correction from this.

Additionally, the low flow cut-off can be activated if required.

Flowmeter sensor

Installation conditions

Installation location and assembly

Note the following points when selecting the installation location and when mounting the sensor:

- The ambient conditions (IP rating, ambient temperature range T_{ambient}) of the device must be adhered to at the installation location.
- Sensors and transmitters must not be exposed to direct sunlight. If necessary, provide a suitable means of sun protection on site. The limit values for ambient temperature T_{ambient} must be adhered to.
- On flange devices, ensure that the counterflanges of the piping are aligned plane parallel. Only install flange devices with suitable gaskets.
- Prevent the sensor from coming into contact with other objects.
- The device is designed for industrial applications. No special EMC protective measures are required if the electromagnetic fields and interference at the installation location of the device comply with 'Best Practice' (in accordance with the standards listed in the declaration of conformity).
Maintain a suitable distance from electromagnetic fields and interference that extend beyond the usual dimensions.

Seals

Users are responsible for selecting and mounting suitable gaskets (material, shape).

Note the following points when selecting and mounting gaskets:

- Use gaskets made from a material that is compatible with the measuring medium and measuring medium temperature.
- Gaskets must not extend into the flow area, since possible turbulence may influence the accuracy of the device.

Inlet and outlet sections

The figures below show the recommended inlet and outlet sections for various installations.

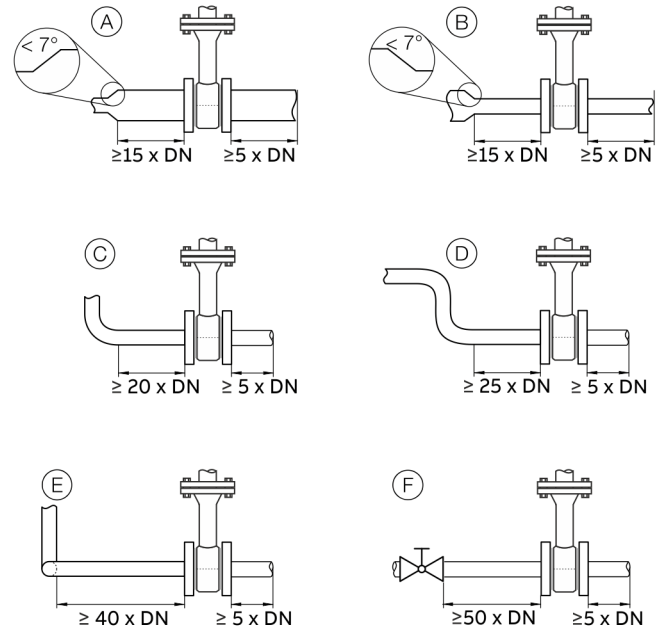

Figure 6: Inlet and outlet sections

Installation	Inlet section	Outlet section
(A) Pipe extension	min. 15 × DN	min. 5 × DN
(B) Pipe reduction	min. 15 × DN	
(C) 90° Pipe elbow	min. 20 × DN	
(D) 2 × 90° pipe elbow in one level	min. 25 × DN	
(E) 2 × 90° pipe elbow in two levels	min. 40 × DN	
(F) Control Valve	min. 50 × DN	

... Flowmeter sensor

To achieve the specified measuring accuracy, the indicated inlet and outlet sections are required.

In case of combinations of several inlet-side effects, e.g. valve and reduction, the longer inlet section must be taken into account.

In case of confined spaces at the installation site, the outlet section can be shortened to $3 \times \text{DN}$. However, reducing the specified inlet section will reduce the achievable level of accuracy.

A high repeatability of the measured value is maintained.

In case of insufficient inlet and outlet sections, a special calibration may be possible. To do this, a detailed reconciliation is necessary for individual cases.

The specified inlet and outlet sections must be doubled for gases with a very low density (hydrogen, helium).

Sensor insulation

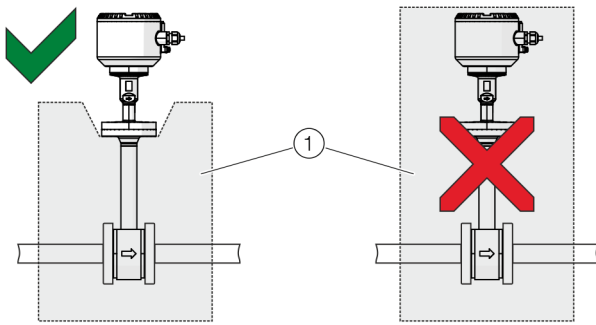

① Insulation

Figure 7: Isolation of the sensor

The sensor may be insulated as shown in **Figure 7**.

Installation at high ambient temperatures

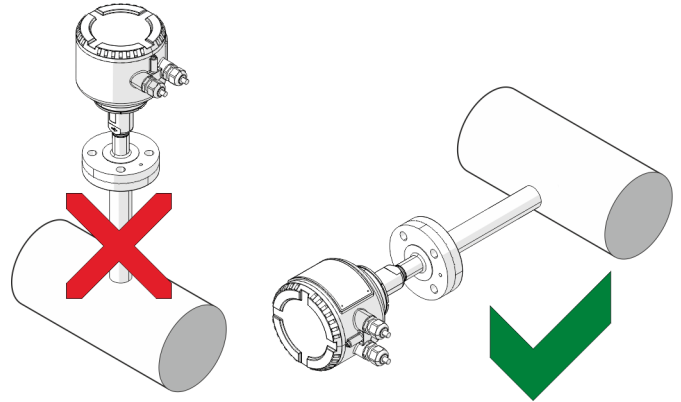

Figure 8: Mounting position at high ambient temperatures

Under high but permissible ambient temperatures, avoid additional thermal stress from heat convection or radiation, since these sources of heat may exceed the permissible ambient temperature on the equipment surface.

If the device needs to be installed directly on a hot, horizontal piping, we recommend installing it on the side. In such cases, you should avoid installing it in the 12 o'clock position, otherwise the warm air that rises up will cause additional heating of the electronics.

NOTICE – Damage of the device due to high ambient temperature!

To prevent device damage through overheating of the electronics, pay attention to the following points:

- If it is being installed close to sources of heat, adequate shielding must be put in place.
- If it is being installed outdoors, sun protection must be provided.

Measuring accuracy

Measured error

The stated measured error only applies under the reference conditions in the stated measuring range. Special calibration on request.

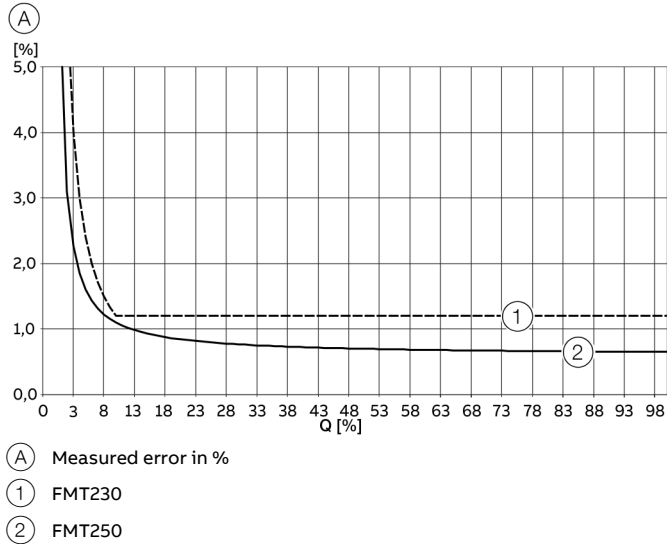

Figure 9: Measured error under reference conditions

Measured medium	FMT230	FMT250
Air	<ul style="list-style-type: none"> ±1.2 % of the measured value in the range of 10 to 100 % of the measuring range ±0.12 % of the measuring range end value possible in the nominal diameter in the range of 0 to 10 % of the measuring range 	<ul style="list-style-type: none"> ±0.6 % of the measured value range end value possible in the nominal diameter
Other gases (with optional operating gas calibration)	—	<ul style="list-style-type: none"> ±1.6 % of the measured value ±0.1 % of the measuring range end value possible in the nominal diameter

Reference conditions

Calibration with air

Calibration gas	Air
Temperature	21 °C, ± 2°C
Pressure	Atmospheric pressure
Relative humidity	40 to 60 %
Test laboratory	In accordance with ISO / IEC 17025

Calibration with process gas

Order code RP, RM

ABB offers the possibility of calibrating thermal mass flowmeters with non-corrosive and non-toxic gases and mixtures of such, subject to availability.

The availability of gases should be inquired prior to ordering with ABB.

For the following gases: argon (Ar), helium (He), hydrogen (H₂) and carbon dioxide (CO₂), ABB recommends operating gas calibration.

The exact reference conditions are noted in the respective calibration certificate.

Repeatability

< 0.2 % of the measured value, measuring time: 10 s

Response time

T₆₃ = 0.5 s

Effect of the measuring medium temperature

< 0.025 % of the measured value per Kelvin (depending on the gas type)

Effect of the measuring medium pressure

< 0.1 % of the measured value per 100 kPa (1 bar) (depending on the gas type)

Influence of the relative humidity of the measuring medium

0.2 % of the measured value per 10 % RH in the range from 15 to 70 % RH

... Flowmeter sensor

Influence of the pipe cross-section

If the inside diameter configured in the device does not correspond with the real diameter of the piping, measuring errors in the flow measurement occur.

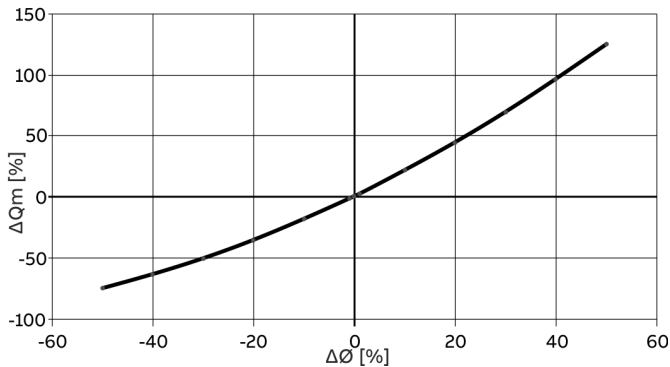

ΔQ_m [%] = Measuring error mass flowmeter in %

$\Delta \varnothing$ [%] = Deviation piping inside diameter in %

Figure 10: Influence of the pipe cross-section

Ambient conditions

Note

When using the device in potentially explosive atmospheres, note the additional temperature data in **Temperature data** on page 33!

Ambient temperature

- Standard: -20 to 70 °C (-4 to 158 °F)
- Optional: -40 to 70 °C (-40 to 158 °F)

Storage temperature range

Standard design:

-20 to 85 °C (-4 to 185 °F),

Low temperature design:

-40 to 85 °C (-40 to 185 °F)

Relative humidity

Maximum 85 % RH, annual average \leq 65 % RH

IP rating

In accordance with EN 60529: IP 65 / IP 67

NEMA IP rating

NEMA 4X

Permitted pipe vibration

In accordance with IEC 60068-2-6

Maximum acceleration: 2 g in the frequency range of 10 to 150 Hz

Process conditions

Note

When using the device in potentially explosive atmospheres, note the additional temperature data in **Temperature data** on page 33!

Measured medium temperature

Devices with ceramic sensor element and flanged connection:

Design	T_{medium}
Standard and explosion-proof design	-20 to 150 °C (-4 to 302 °F)
High temperature design*	-20 to 300 °C (-4 to 572 °F)
Low temperature design	-40 to 150 °C (-40 to 302 °F)
DVGW Version	-20 to 100 °C (-4 to 212 °F)

* Not in connection with explosion-proof design.

The approved measuring medium temperature T_{medium} also depends on the selected sensor connection and the design of the pipe components.

The following temperature specifications apply:

Sensor connection	T_{medium}
Flange DN25	-40 to maximum 300 °C (-40 to maximum 508 °F)
Threaded connection DIN 11851	-20 to 140 °C (-4 to 284 °F)
Clamp ring fitting	-40 to 150 °C (-40 to 302 °F)
Pipe components with ball valve	Maximum 150 °C (302 °F)
Integrated hot tap fitting	-20 to 150 °C (-4 to 302 °F)

Maximum operating pressure

Sensor connection	Maximum measuring medium pressure P_{medium}
Flange in accordance with DIN EN 1092, PN 40	4 MPa, 40 bar (580 psi)
Threaded connection DIN 11851	1.6 MPa, 16 bar (232 psi)
Clamp ring fitting	2 MPa, 20 bar (290 psi)
Integrated hot tap fitting	See Integrated hot tap fitting on page 29

Pressure loss

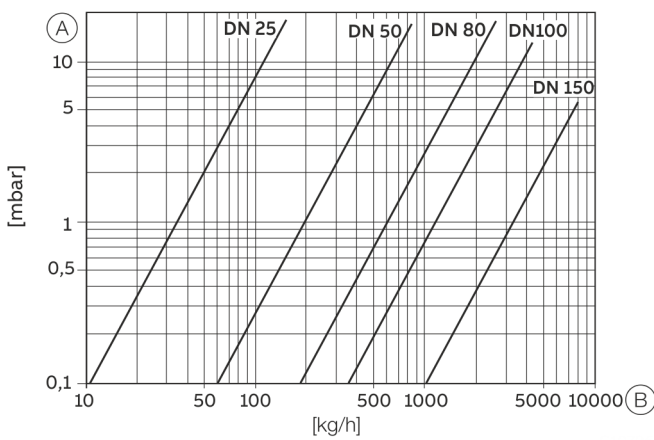

(A) Pressure loss

(B) Mass flow

Figure 11: Pressure loss in logarithmic representation

Sensor installation length

The sensor is available in different installation lengths. Refer to **Sensor** on page 21.

Sensor connection

The following sensor connections are available for connecting the sensor to the pipe components or the process:

Sensor connection
Flange in accordance with EN 1092-1 DN 25, PN 40
Male thread in accordance with DIN 11851, PN 16
Compression fitting NPT 1 in male thread, PN 20

Materials

Materials for the sensor

Wetted components	Material
Sensor	Stainless steel 1.4404 (AISI 316L)
Sensor element	Ceramic
Sensor connection gasket (O-ring)	<ul style="list-style-type: none"> • Viton® (standard) • Kalrez® 4079 / Kalrez® 1050 (for high temperature design) • Kalrez® 1050 (for oxygen) • Kalrez® Spectrum 6375 (for ammonia) • EPDM (DIN 11851) • FKM® (for low temperature design) • HNBR® (for DVGW design)

... Flowmeter sensor

Measuring range table

Non-Ex areas / Zone 2 / Division 2

The recommended value for applications with air (other gases on request) under atmospheric conditions. For hydrogen and helium, the measuring range lower limit is typically approx. 10 % of the upper limit.

Devices with process connections in accordance with EN 1029-1

Nominal diameter	Standard measuring range		Extended measuring range	
	Q _{max} [kg/h]	Q _{max} [Nm ³ /h]**	Q _{max} [kg/h]	Q _{max} [Nm ³ /h]**
DN 25 (1 in)	180	140	240	180
DN 40 (1½ in)	450	350	590	450
DN 50 (2 in)	800	620	1050	800
DN 65 (2½ in)	1400	1100	1800	1400
DN 80 (3 in)	1900	1500	2500	1900
DN 100 (4 in)	3200	2500	4100	3200
DN 125 (5 in)	4800	3800	6200	4800
DN 150 (6 in)	7000	5500	9000	7000
DN 200 (8 in)	11800	9200	15000	12000
Ø to 3000 mm (118 in)*	2500000	1900000	3200000	2500000

Device with process connections in accordance with ASME B16.5

Nominal diameter	Standard measuring range		Extended measuring range	
	Q _{max} [lbs/h]	Q _{max} [ft ³ /h]**	Q _{max} [lbs/h]	Q _{max} [ft ³ /h]**
1 in	350	4500	450	5900
1½ in	880	11000	1100	14500
2 in	1600	21000	2000	28000
3 in	3700	50000	4900	66000
4 in	6400	83000	8400	108000
6 in	14500	190000	19000	248000
8 in	25500	325000	33100	425000
Ø to 3000 mm (118 in)*	5500000	71000000	7100000	93000000

* Rectangular ducts and larger diameters on request

** Applies for air at 0 °C (32 °F) / 1013.25 hPa (14.696 psia)

*** Applies for air at 15 °C (59 °F) / 1013.25 hPa (14.696 psia)

Zone 0 / Zone 1 / Division 1**Devices with process connections in accordance with EN 1029-1**

Nominal diameter	Q _{max} [kg/h]	Q _{max} [Nm ³ /h]**
DN 25 (1 in)	150	120
DN 40 (1½ in)	380	300
DN 50 (2 in)	650	500
DN 65 (2½ in)	1200	920
DN 80 (3 in)	1700	1300
DN 100 (4 in)	3000	2300
DN 125 (5 in)	4500	3500
DN 150 (6 in)	6500	5000
DN 200 (8 in)	11000	8500
Ø to 3000 mm (118 in)*	2300000	1800000

Device with process connections in accordance with ASME B16.5

Nominal diameter	Q _{max} [lbs/h]	Q _{max} [ft ³ /h]***
1 in	290	3800
1½ in	750	10000
2 in	1400	18000
3 in	3400	45000
4 in	6000	80000
6 in	14000	180000
8 in	24000	310000

* Rectangular ducts and larger diameters on request

** Applies for air at 0 °C (32 °F) / 1013.25 hPa (14.696 psia)

*** Applies for air at 15 °C (59 °F) / 1013.25 hPa (14.696 psia)

Note

For additional information on dependencies and restrictions, and for help on product selection, please refer to the Online ABB Product Selection Assistant (PSA) for flow rate at abb.com/flow-selector.

Transmitter

Electrical connections

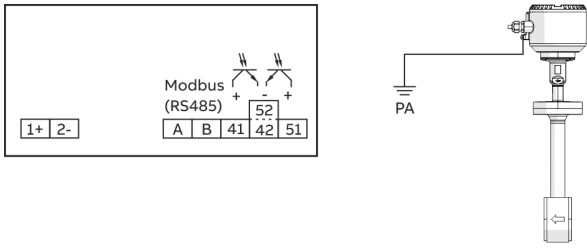

Figure 12: Electrical connection PA = functional ground (potential equalization)

Connections for the power supply

DC voltage	
Terminal	Function / comments
1+	+
2-	-

Connections for the outputs

Terminal	Function/comments
A / B	Modbus RTU (RS485)
41 / 42	Passive digital output DO1 The output can be configured as a pulse output, frequency output or switch output.
51 / 52	Passive digital output DO2 The output can be configured as a pulse output, frequency output or switch output.

Electrical data for inputs and outputs

Note

When using the device in potentially explosive atmospheres, note the additional connection data in **Use in potentially explosive atmospheres** on page 30!

Power supply

Supply voltage	24 V DC ± 20 % (ripple: ≤ 5 %)
Power consumption	P ≤ 10 W

Digital output 41 / 42, 51 / 52 Can be configured via Modbus.

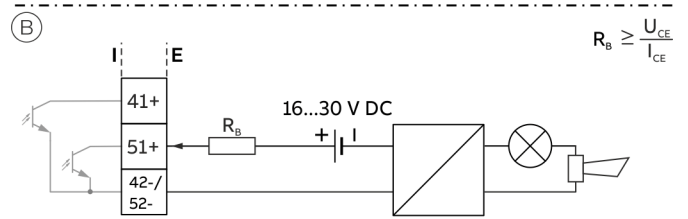
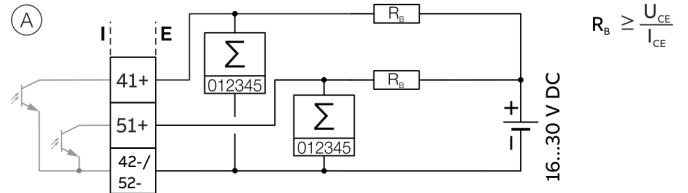

- (A) Passive digital output 41 / 42 as pulse or frequency output, Passive digital output 51 / 52 as pulse output
- (B) Passive digital output 51 / 52 as binary output

Figure 13: Passive digital outputs (I = internal, E = external)

Pulse / frequency output (passive)	
Terminals	41 / 42 (pulse / frequency output) 51 / 52 (pulse output)
Output 'closed'	0 V ≤ U _{CEL} ≤ 3 V For f < 2.5 kHz: 2 mA < I _{CEL} < 30 mA For f > 2.5 kHz: 10 mA < I _{CEL} < 30 mA
Output 'open'	16 V ≤ U _{CEH} ≤ 30 V DC 0 mA ≤ I _{CEH} ≤ 0.2 mA
f _{max}	10.5 kHz
Pulse width	0.1 to 2000 ms

Binary output (passive)	
Terminals	41 / 42, 51 / 52
Output 'closed'	0 V ≤ U _{CEL} ≤ 3 V 2 mA ≤ I _{CEL} ≤ 30 mA
Output 'open'	16 V ≤ U _{CEH} ≤ 30 V DC 0 mA ≤ I _{CEH} ≤ 0.2 mA
Switching function	Configurable

Note

- Digital output 51 / 52 **cannot** be configured as a frequency output.
- Terminals 42 / 52 have the same potential. Digital outputs 41 / 42 and 51 / 52 are not electrically isolated from each other.
- If you are using a mechanical counter, we recommend setting a pulse width of ≥ 30 ms and a maximum frequency of f_{max} ≤ 3 kHz.

Modbus® communication

Note

The Modbus® protocol is an unsecured protocol, as such the intended application should be assessed to ensure that these protocols are suitable before implementation.

Modbus is an open standard owned and administrated by an independent group of device manufacturers styled the Modbus Organization (www.modbus.org/).

Using the Modbus protocol allows devices made by different manufacturers to exchange information via the same communication bus, without the need for any special interface devices to be used.

Modbus protocol	
Terminals	V1 / V2
Configuration	Via the Modbus interface or via the local operating interface in connection with a corresponding Device Type Manager (DTM)
Transmission	Modbus RTU - RS485 serial connection
Baud rate	2400, 4800, 9600, 19200, 38400, 56000, 57600, 115200 baud Factory setting: 9600 baud
Parity	None, even, odd Factory setting: odd
Stop bit	One, two Factory setting: One
IEEE format	Little endian, big endian Factory setting: Little endian
Typical response time	< 100 ms
Response delay time	0 to 200 milliseconds Factory setting: 10 milliseconds

Cable specification

The maximum permissible length is dependent on the baud rate, the cable (diameter, capacity and surge impedance), the number of loads in the device chain, and the network configuration (2-core or 4-core).

- At a baud rate of 9600 and with a conductor cross-section of at least 0.14 mm² (AWG 26), the maximum length is 1000 m (3280 ft).
- When using a 4-core cable as a 2-wire wiring system, the maximum length must be halved.
- The spur lines must be short, a maximum of 20 m (66 ft).
- When using a distributor with 'n' connections, each branch must have a maximum length of 40 m (131 ft) divided by 'n.'

The maximum cable length depends on the type of cable used. The following standard values apply:

- Up to 6 m (20 ft): cable with standard shielding or twisted-pair cable.
- Up to 300 m (984 ft): double twisted-pair cable with overall foil shielding and integrated earth cable.
- Up to 1200 m (3937 ft): double twisted-pair cable with individual foil shielding and integrated earth cables. Example: Belden 9729 or equivalent cable.

A category 5 cable can be used for Modbus RS485 up to a maximum length of 600 m (1968 ft). For the symmetrical pairs in RS485 systems, a surge impedance of more than 100 Ω is preferred, especially at a baud rate of 19200 and above.

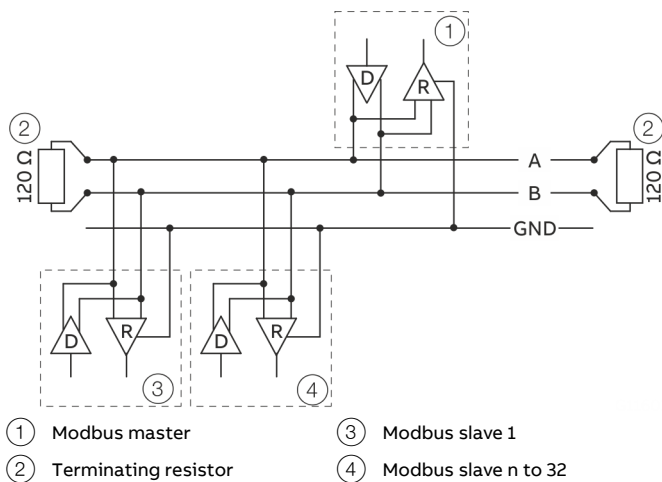

Figure 14: Communication with the Modbus protocol

... Transmitter

Materials

Materials for the transmitter terminal box

Housing

- Aluminum EN AC-44200 (YL104)

or

- Stainless steel 1.4409 (ASTM CF3M)

Housing color (only for aluminum housing)

- RAL 9002

Layer thickness of the paint: 80 to 120 µm

Pipe components

Process connections

The pipe components are available with the following process connections:

Type	Process connection
FMT091	Wafer type design <ul style="list-style-type: none"> DN 25 to 200, PN 40 in accordance with EN 1092-1 1 to 8 in, CL 150 / CL 300 in accordance with ASME B 16.5
FMT092	Partial measuring section (optional with flow straightener) <ul style="list-style-type: none"> DN 25 to 100, PN 40, flange in accordance with EN 1092-1 1 to 8 in, CL 150 / CL 300, flange in accordance with ASME B 16.5 DN 25 to 80, PN 10, flange in accordance with EN1092-1 B1 DN 25 to 80, PN 10, male thread R1 to 3 in
FMT094	Weld-on adapter The ball valve variants are available for all designs (FMT091/FMT092/FMT094) for rectangular ducts or pipe diameters DN 100 to 3000.

The pipe components are available optionally with ball valve or integrated hot tap fitting.

- The pipe components with ball valve are approved for use in ATEX/IECEX/UKEX Zone 2 or cFMus Div. 2.
- The integrated hot tap fitting is approved for use in ATEX/IECEX/UKEX Zone 1, Zone 2 (not Zone 0) or cFMus Div. 1 and Div. 2.
- For information on measuring medium temperature, see **Measured medium temperature** on page 12.

The installation length of the sensor must be taken into account when selecting the pipe component!

Materials

Wetted materials for the pipe components

Type	Material
FMT091 Wafer type design	Stainless steel 1.4571 (AISI 316 Ti)
FMT092 Partial measuring section	Stainless steel 1.4571 (AISI 316 Ti) or stainless steel 1.4301 (AISI 304)
Partial measuring section with male thread	Steel, galvanized
FMT094 Weld-on adapter	Stainless steel 1.4571 (AISI 316 Ti) optional: carbon steel 1.0037 (S 235)

Material loads for process connections

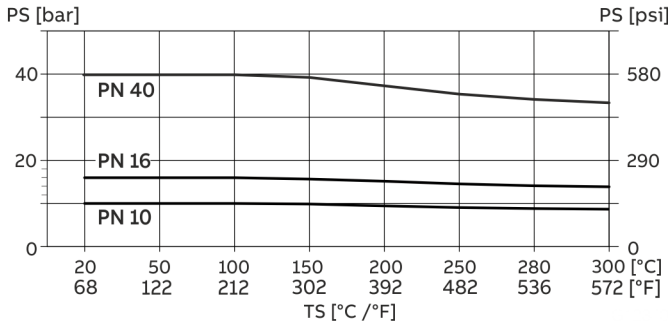

Figure 15: DIN flange process connection

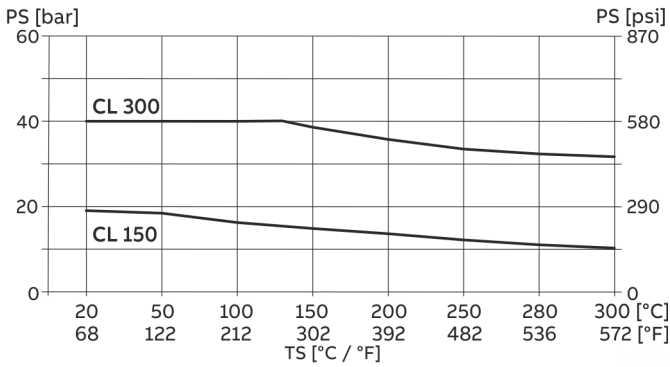

Figure 16: ASME flange process connection

The maximum approved operating pressure for CL 300 is limited to 40 bar (580 psi).

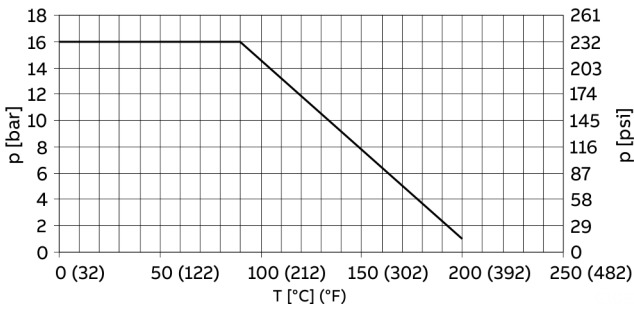

Figure 17: Maximum pressure/temperature values for integrated hot tap fitting

Integrated hot tap fitting

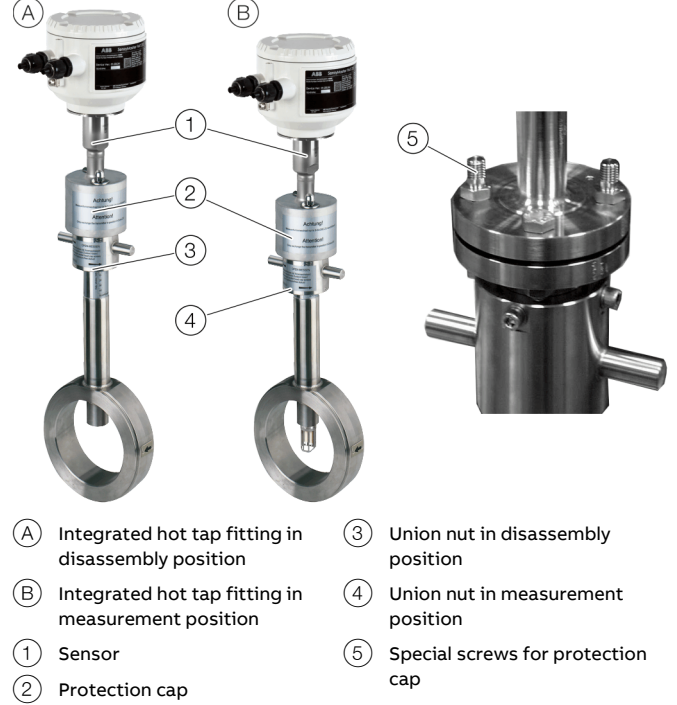

Figure 18: Integrated hot tap fitting (example)

The integrated hot tap fitting is used in conjunction with the previously described pipe components and weld-on adapters if it should be possible to remove the sensor during running operation.

The hot tap fitting is recommended for measurements in main lines (for example pressurized air supply) or at measuring points that need to be rinsed before the sensor is disassembled.

In general, a hot tap fitting should be used in case of measurements that make shutting-off device parts necessary to remove the sensor.

... Pipe components

Explosion protection approval

The integrated hot tap fitting is approved for use in potentially explosive atmospheres of ATEX/IECEX/UKEX Zone 1 and Zone 2 or cFMus Div. 1 and Div. 2.

Use in Zone 0 is not permitted!

Measuring medium temperature

Refer to **Measured medium temperature** on page 12.

Process connection

The integrated hot tap fitting is available in wafer type or welding design.

Connection flanges PN 16 with four screw holes must be used in the integrated hot tap fitting in wafer type design DN 65.

Wafer type designs 2 to 8 in only for connection flanges in accordance with ASME B16.5, CI 150.

Dimensions

Sensor

All dimensions and weights are specified in mm (in) or kg (lb).

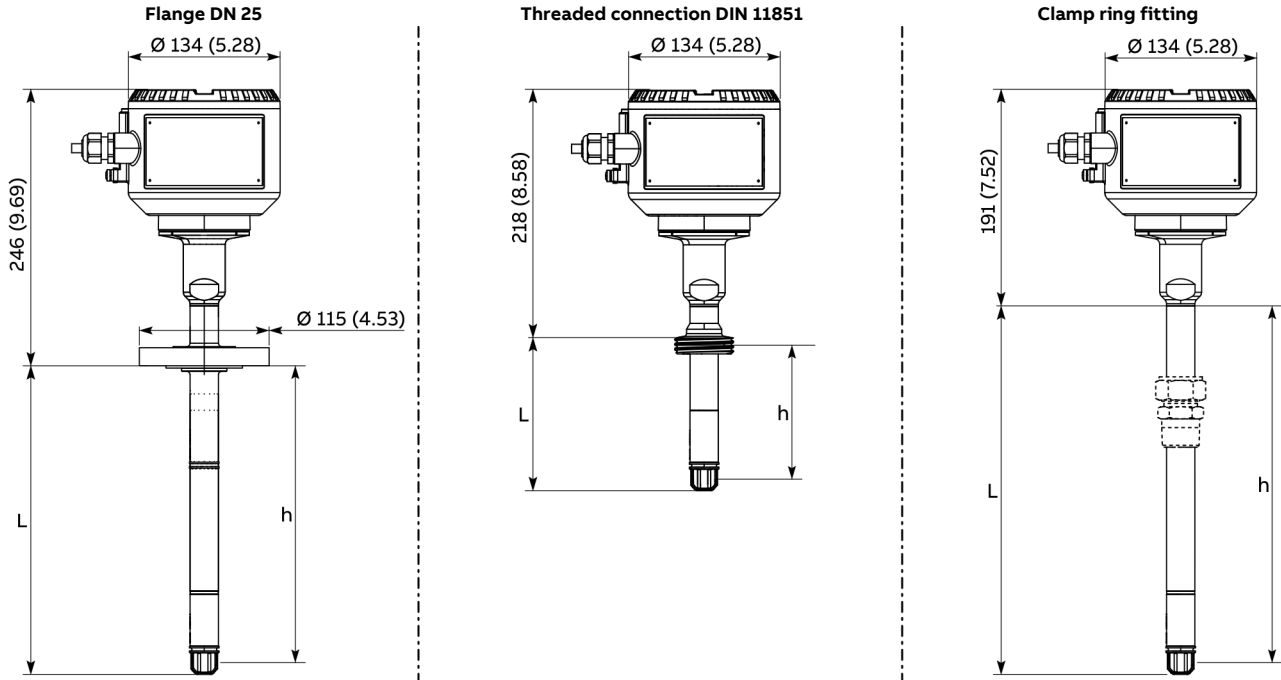

Figure 19: Sensor

Sensor connection	For nominal piping diameter	L	h (installation length)	Approximate weight
		mm (in)	mm (in)	Kg (lb)
Flange DN 25	DN 25 to 350 (1 to 14 in)	271 (10.64)	263 (10.35)	5 (11)
	> DN 350 to 700 (> 14 to 28 in)	433 (17.05)	425 (16.73)	5.5 (12)
	> DN 700 (> 28 in)	783 (30.83)	775 (30.51)	6 (13)
Clamp ring fitting	DN 25 to 350 (1 to 14 in)	326 (12.83)	318 (12.52)	4 (8.8)
	> DN 350 to 700 (> 14 to 28 in)	488 (19.21)	480 (18.90)	4.5 (9.9)
	> DN 700 (> 28 in)	838 (32.99)	830 (32.68)	5.5 (12)
Threaded connection DIN 11851	DN 25 to 80 (1 to 3 in)	136 (5.53)	120 (4.72)	3.2 (7)

Note

The specified nominal piping diameters apply for the use of the sensor with pipe components without ball valves or hot tap fittings.

... Dimensions

Pipe components

All dimensions and weights are specified in mm (in) or kg (lb).

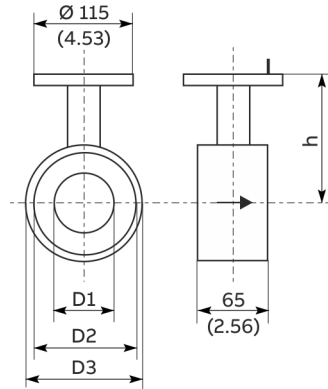

FMT091 – Wafer type design

Figure 20: Wafer type design dimensions

FMT091 – Wafer type design in accordance with EN 1092-1, PN 40 – Sensor connection: flange DN 25

Nominal diameter	h	D1	D2	D3	Weight
DN 40	263 (10.35)	43.1 (1.70)	88 (3.46)	94 (3.70)	4.5 (10)
DN 50		54.5 (2.15)	102 (4.02)	109 (4.29)	5.0 (11)
DN 65		70.3 (2.77)	122 (4.80)	129 (5.08)	—
DN 80		82.5 (3.25)	138 (5.43)	144 (5.67)	7.0 (15.5)
DN 100		107.1 (4.22)	162 (6.38)	170 (6.69)	8.5 (18.7)
DN 125		131.7 (5.19)	188 (7.40)	196 (7.72)	—
DN 150		159.3 (6.27)	218 (8.58)	226 (8.90)	11.5 (25.5)
DN 200		206.5 (8.13)	285 (11.22)	293 (11.54)	—

FMT091 – Wafer type design in accordance with ASME B 16.5, CL 150 – Sensor connection: flange DN 25

Nominal diameter	h	D1	D2	D3	Weight
1½ in	263 (10.35)	40.9 (1.61)	73 (2.87)	85 (3.35)	—
2 in		52.6 (2.07)	92 (3.62)	103 (4.06)	—
3 in		78.0 (3.07)	127 (5.00)	135 (5.31)	—
4 in		102.4 (4.03)	157 (6.18)	173 (6.81)	—
6 in		154.2 (6.07)	216 (8.50)	221 (8.70)	—
8 in		202.7 (7.98)	270 (10.63)	278 (10.94)	—

FMT091 – Wafer type design in accordance with ASME B 16.5, CL 300 – Sensor connection: flange DN 25

Nominal diameter	h	D1	D2	D3	Weight
1½ in	263 (10.35)	40.9 (1.61)	73 (2.87)	94 (3.70)	—
2 in		52.6 (2.07)	92 (3.62)	110 (4.33)	—
3 in		78.0 (3.07)	127 (5.00)	148 (5.83)	—
4 in		102.4 (4.03)	157 (6.18)	180 (7.09)	—
6 in		154.2 (6.07)	216 (8.50)	249 (9.80)	—
8 in		202.7 (7.98)	270 (10.63)	307 (12.09)	—

All dimensions and weights are specified in mm (in) or kg (lb).

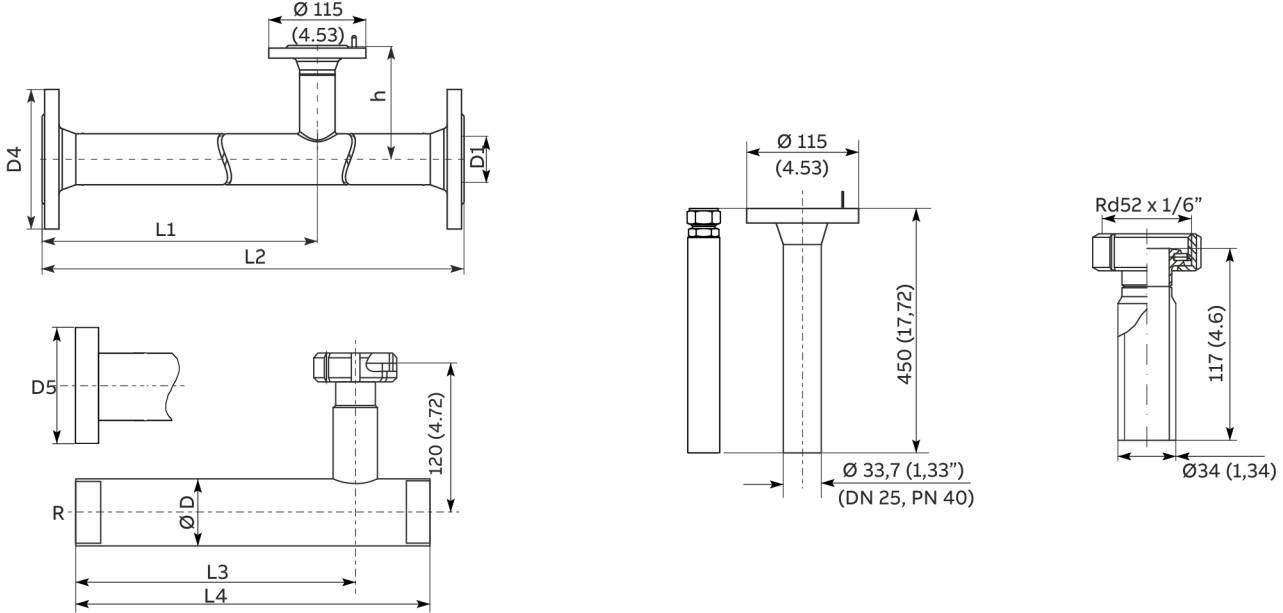

Figure 21:

FMT092 – Partial measuring section with flange in accordance with EN 1092-1, Form B1, PN 40 – Sensor connection: flange DN 25							
Nominal diameter	h	D1	D4	L1	L2	Weight	
DN 25	263 (10.35)	28.5 (1.12)	115 (4.53)	486 (19.13)	600 (23.62)	5.5 (12.0)	
DN 40		43.1 (1.70)	150 (5.91)	731 (28.78)	860 (33.86)	8.0 (17.5)	
DN 50		54.5 (2.15)	165 (6.50)	837 (32.95)	1000 (39.37)	11 (24.3)	
DN 65		70.3 (2.77)	185 (7.28)	1190 (46.85)	1400 (55.12)	16.5 (36)	
DN 80		82.5 (3.25)	200 (7.87)	1450 (57.09)	1700 (66.93)	22.5 (49)	
DN 100		107.1 (4.22)	235 (9.25)	1870 (73.62)	2200 (86.61)	34 (74)	

FMT092 – Partial measuring section with flange in accordance with EN 1092-1, Form B1, PN 10 – Sensor connection: threaded connection DIN 11851						
Nominal diameter	ØD inside	D5	L3	L4	Weight	
DN 25	27.3 (1.07)	115 (4.53)	410 (16.14)	550 (21.65)	–	
DN 40	41.9 (1.65)	150 (5.91)	615 (24.21)	820 (32.28)	–	
DN 50	53.9 (2.12)	165 (6.50)	810 (31.89)	1080 (42.52)	–	
DN 80	79.9 (3.15)	200 (7.87)	1200 (47.24)	1600 (62.99)	–	

FMT092 – Partial measuring section with male thread, PN 10 – sensor connection: threaded connection DIN 11851						
Nominal diameter	ØD inside	R male thread	L3	L4	Weight	
DN 25	27.3 (1.07)	R1" – 33.7 x 1.2	410 (16.14)	550 (21.65)	–	
DN 40	41.9 (1.65)	R1 1/2" – 48.3 x 3.2	615 (24.21)	820 (32.28)	–	
DN 50	53.9 (2.12)	R2" – 60.3 x 3.2	810 (31.89)	1080 (42.52)	–	
DN 80	79.9 (3.15)	R3" – 88.9 x 4.5	1200 (47.24)	1600 (62.99)	–	

... Dimensions

All dimensions and weights are specified in mm (in) or kg (lb).

FMT092 – Partial measuring section with flange in accordance with ASME B 16.5, CL 150 – Sensor connection: flange DN 25						
Nominal diameter	h	D1	D4	L1	L2	Weight
1 in	263 (10.35)	26.6 (1.05)	108 (4.25)	454 (17.87)	560 (22.05)	5.1 (11)
1½ in		40.9 (1.61)	127 (5.00)	741 (29.17)	864 (34.02)	7.6 (16.5)
2 in		52.6 (2.07)	154 (6.06)	846 (33.31)	1003 (39.49)	12.3 (26.8)
3 in		78.0 (3.07)	–	–	–	21.3 (46)
4 in		102.4 (4.03)	–	–	–	32.5 (71)

FMT092 – Partial measuring section with flange in accordance with ASME B 16.5, CL 300 – Sensor connection: flange DN 25						
Nominal diameter	h	d1	D4	L4	L3	Weight
1 in	263 (10.35)	26.6 (1.05)	123.9 (4.88)	454 (17.87)	560 (22.05)	–
1½ in		40.9 (1.61)	155.4 (6.12)	741 (29.17)	864 (34.02)	–
2 in		52.6 (2.07)	165.1 (6.50)	846 (33.31)	1003 (39.49)	–
3 in		78.0 (3.07)	–	–	–	–
4 in		102.4 (4.03)	–	–	–	–

Welding adapter

Dimensions in mm (in)

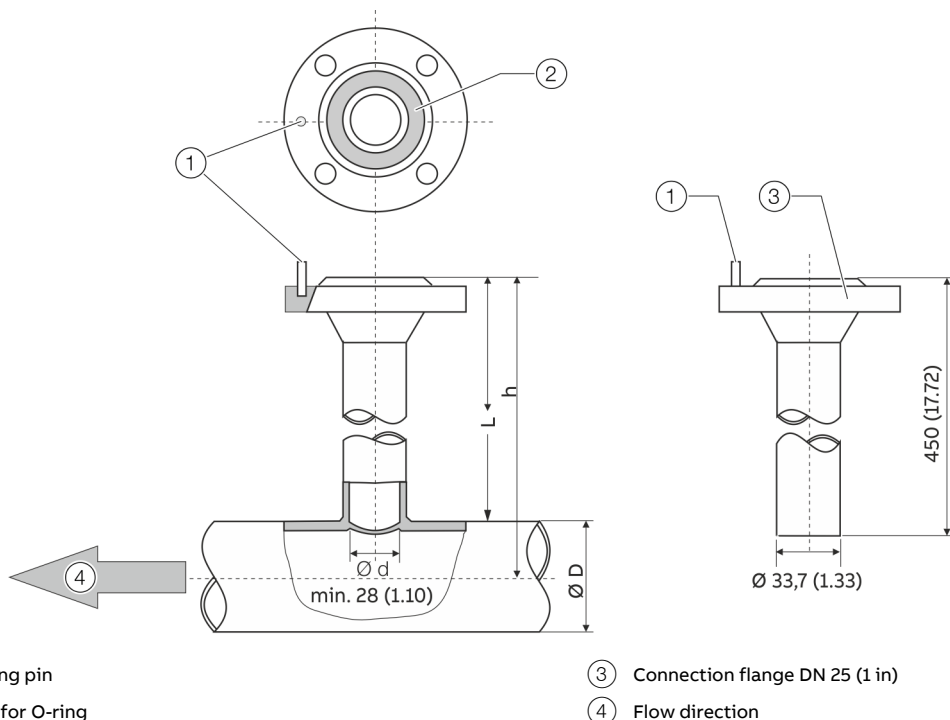

- ① Centering pin
- ② Groove for O-ring
- ③ Connection flange DN 25 (1 in)
- ④ Flow direction

Figure 22: Dimensions in mm (in)

h – sensor length	Ø D – outer pipe diameter
263 (10.35)	80 to 350 (3.24 to 13.78)
425 (16.73)	> 350 to 700 (> 13.78 to 27.56)
775 (30.51)	> 700 to 1400 (> 27.56 to 55.12)*

* The limitation of the maximum pipe diameter only applies for installations with a sensor element in the middle of the pipe. In case of larger or non-round cross-sections, a non-centered position of the measuring element in the piping is considered in the calibration.

Note

When mounting the weld-on adapter, observe the following points:

- The welding adapters must be shortened to the dimension L before installation, in accordance with: $L = h - (1/2 \times \varnothing D)$.
- The distance h from the upper edge of the flange to the pipe central axis must be within a tolerance of ± 2 mm (± 0.08 ").
- Maintain the right angle to the pipe axis (max. tolerance $\pm 2^\circ$).
- The adapter centering pin must be aligned with the pipe axis in the flow direction (outflow side, behind the measuring point).

... Dimensions

Weld-on adapter with ball valve

Dimensions in mm (in)

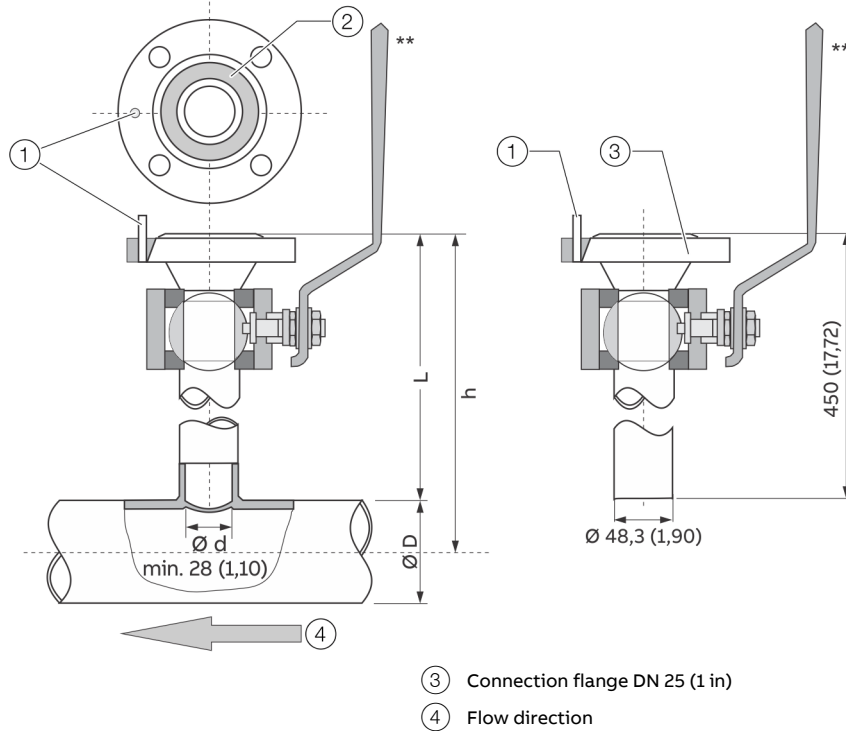

Figure 23: Dimensions in mm (in)

h – sensor length	Ø D - outer pipe diameter
263 (10.35)	80 to 150 (3.24 to 5.91)
425 (16.73)	> 150 to 500 (> 5.91 to 19.69)
775 (30.51)	> 500 to 1150 (> 19.69 to 45.28)*

* The limitation of the maximum pipe diameter only applies for installations with a sensor element in the middle of the pipe. In case of larger or non-round cross-sections, a non-centered position of the measuring element in the piping is considered in the calibration.

** Ball valve T_{medium} : maximum 150 °C (302 °F), explosion protection approval for use in ATEX/IECEX/UKEX Zone 2 or cFMus Div. 2.

Note

When mounting the weld-on adapter, observe the following points:

- The welding adapters must be shortened to the dimension L before installation, in accordance with: $L = h - (1/2 \times \text{Ø D})$.
- The distance h from the upper edge of the flange to the pipe central axis must be within a tolerance of $\pm 2 \text{ mm}$ ($\pm 0.08''$).
- Maintain the right angle to the pipe axis (max. tolerance $\pm 2^\circ$).
- The adapter centering pin must be aligned with the pipe axis in the flow direction (outflow side, behind the measuring point).

Welding adapter with threaded connection in accordance with DIN 11851

Dimensions in mm (in)

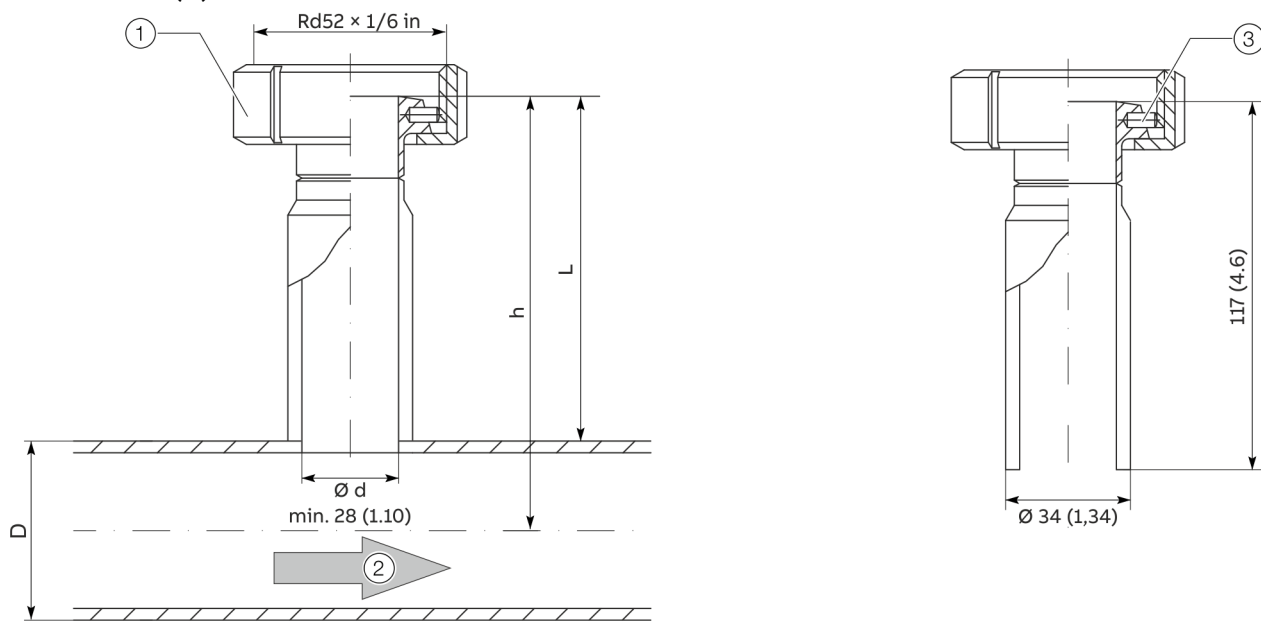

① Union nut

② Flow direction

③ Centering pin

Figure 24: Dimensions in mm (in)

Note

When mounting the weld-on adapter, observe the following points:

- Always mount the weld-on adapter together with the union nut on the piping. Mounting it at a later time is not possible.
- The welding adapters must be shortened to the dimension L before installation, in accordance with: $L = h - (1/2 \times \text{Ø } D)$.
- The distance h from the upper edge of the adapter to the pipe central axis must be within a tolerance of $\pm 2 \text{ mm}$ ($\pm 0.08 \text{ inch}$).
- Maintain the right angle to the pipe axis (max. tolerance $\pm 2^\circ$).
- Observe the thickness of pipeline wall and the degree of shrinkage when welding on.
- The adapter centering pin must be aligned with the pipe axis in the flow direction (outflow side, behind the measuring point).
- Once welding is complete, there must be a passage of at least 28 mm (1.10 inch) free for the purpose of mounting the sensor (drill to create if necessary)

... Dimensions

Welding adapter with compression fitting

All dimensions in mm (in)

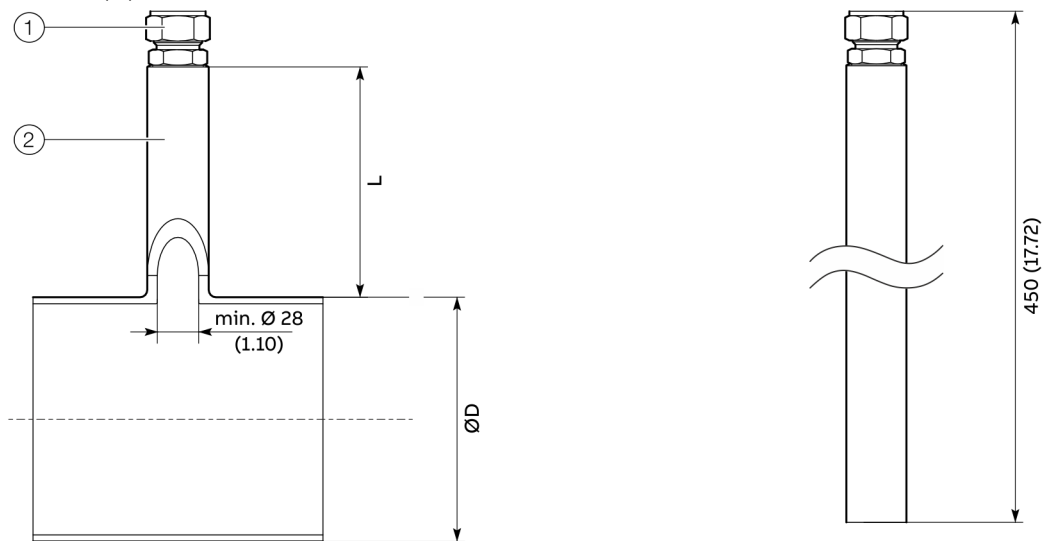

① Compression fitting

② Welding tube for the compression fitting

Figure 25: Welding adapter with compression fitting

h – sensor length	h3 – installation length	$L = h3 - (\frac{1}{2} \times \text{ØD})$	Ø D – outer pipe diameter*
263 (10.35)	244 (9.61)	to be calculated	≥ 80 to 350 (≥ 3.24 to 13.78)
425 (16.73)	406 (15.98)		> 350 to 700 (> 13.78 to 27.56)
775 (30.51)	756 (29.76)		> 700 to 1400 (> 27.56 to 55.12)

Table 1: Dimensions of welding adapter with compression fitting

* The limitation of the maximum pipe diameter only applies for installations with thermal sensor elements in the middle of the pipe. In case of larger or non-round cross-sections, a non-centered position of the thermal sensor elements in the piping is considered in the calibration.

Note

When installing the adapter tubes for compression fittings, observe the following points:

- The welding adapter tubes should be shortened to dimension L before installation, in accordance with: $L = h3 - (\frac{1}{2} \times \text{ØD})$
- It is imperative that you maintain a right angle to the longitudinal and transversal axes of the meter tube (maximum tolerance $\pm 2^\circ$).
- Make sure that after welding the free opening of the adapter tube is at least $\text{Ø}28$ mm (1.10 in).

Integrated hot tap fitting

Dimensions in mm (in)

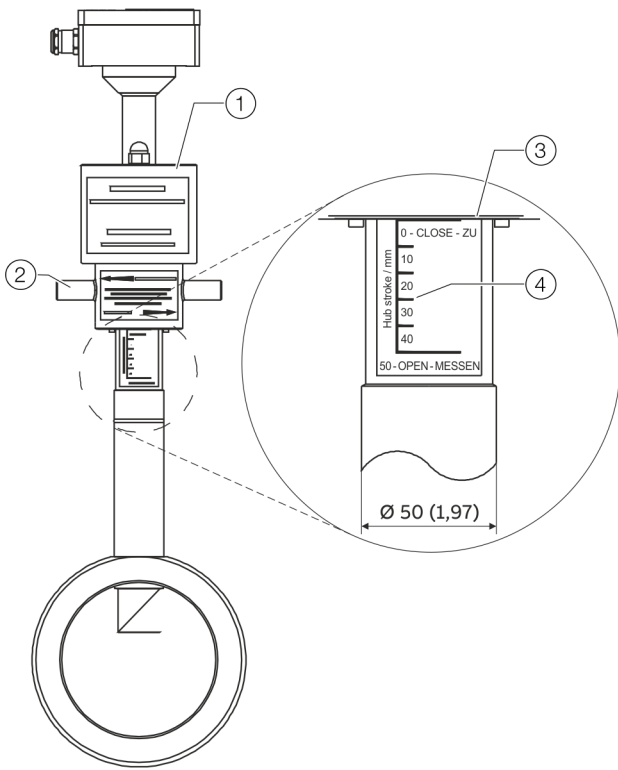

Wafer type design

- ① Cover plate for flange DN 25 (1 in)
- ② Union nut
- ③ Lower edge of union nut

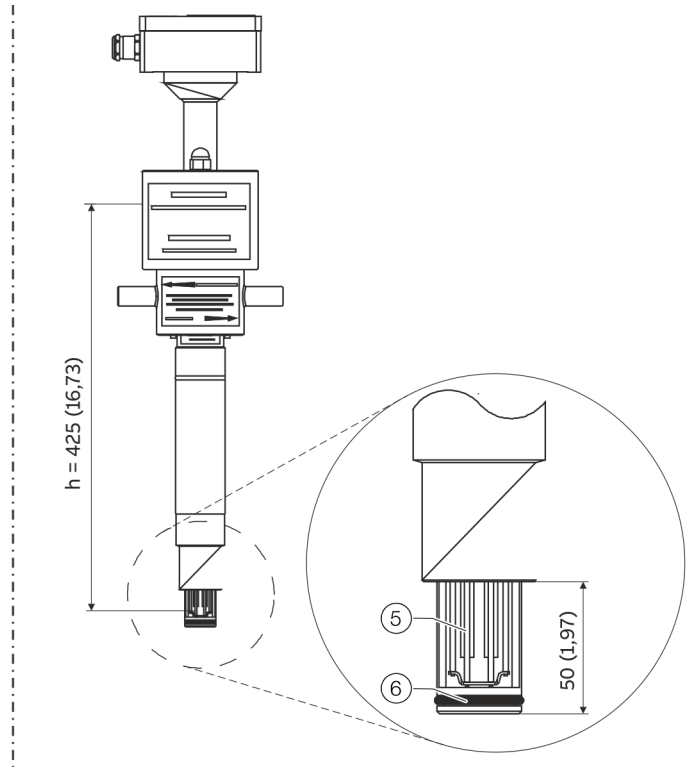

Welding adapter design

- ④ Display sensor element position, stroke 50 mm (1.97 in)
- ⑤ Sensor element
- ⑥ O-ring

Figure 26: Hot tap fitting

Nominal diameter	h – sensor length	
	Wafer type design	Welding design
DN 50, DN 65, DN 80 (2 in, 3 in)	263 mm (10.35 in)	425 mm (16.73 in) from nominal diameter DN 80
DN 100, DN 125, DN 150, DN 200 (4 in, 6 in, 8 in)	425 mm (16.73 in)	





Use in potentially explosive atmospheres

Note

Further information on the approval of devices for use in potentially explosive atmospheres can be found in the type examination certificates or the relevant certificates at www.abb.com/flow.

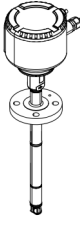
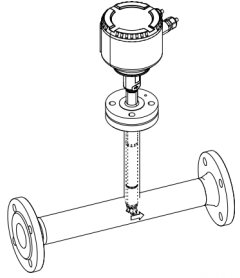
Device overview

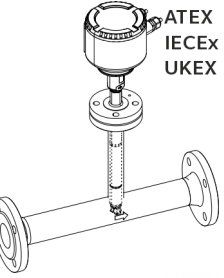
ATEX, IECEx and UKEX

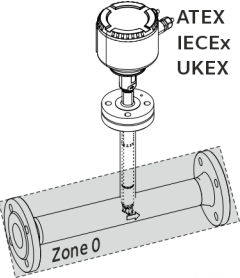
	Standard / No explosion protection		Zones 2, 22		Zone 1, 21 (Zone 0)	
Model number	FMT2xx Y0		FMT2xx A2, U2		FMT2xx A1, A3, U1, U4	
<ul style="list-style-type: none"> • Standard • Zone 2, 22 • Zone 1, 21 • Zone 0 						

cFMus

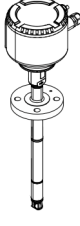
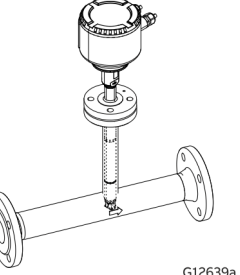
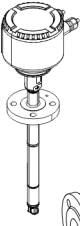
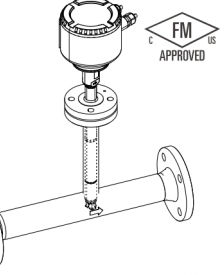
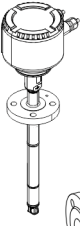
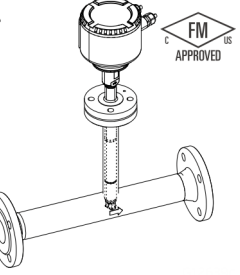
	Standard / No explosion protection		Class I Div. 2 Zone 2, 22		Class I Div. 1 Zone 1, 21	
Model number	FMT2xx Y0		FMT2xx F2		FMT2xx F1	
<ul style="list-style-type: none"> • Standard • Class I Div. 2 • Class I Div. 1 • Zone 2, 22 • Zone 1, 21 						

Ex marking: flowmeter

Note

- A specific marking applies, depending on the design.
- ABB reserves the right to modify the Ex-marking. Refer to the name plate for the exact marking.

ATEX, IECEx and UKEX

Model FMT2xx-A2, U2... in Zone 2, 22

Certificate (Atex)	FM19ATEX0178X
Certificate (IECEX)	IECEX FMG 19.0025X
Certificate (UKEX)	FM21UKEX0136X
II 3G Ex ec mc IIC T6...T2 Gc	
II 3D Ex tc IIIC T85°C...T _{medium} Dc	

Model FMT2xx-A1, U1... in Zone 1, 21

Certificate (Atex)	FM19ATEX0177X
Certificate (IECEX)	IECEX FMG 19.0025X
Certificate (UKEX)	FM21UKEX0135X
II 2G Ex eb ia mb IIC T6...T2 Gb	
II 2G Ex ia IIC T6...T1 Gb	
II 2D Ex ia tb IIIC T85°C...T _{medium} Db	
permitted supply short-circuit current: 35A	

Model FMT2xx-A3, U4... in Zone 0, 1, 21

Certificate (Atex)	FM19ATEX0177X
Certificate (IECEX)	IECEX FMG 19.0025X
Certificate (UKEX)	FM21UKEX0135X
II 1/2 G Ex eb ia mb IIC T6...T2 Ga/Gb	
II 1G Ex ia IIC T6...T1 Ga	
II 2D Ex ia tb IIIC T85°C...T _{medium} Db	
permitted supply short-circuit current: 35A	

cFMus

Designation for model FMT2xx-F2... in Division 2

FM (marking for US)	
Certificate	FM19US0110X
NI: CL I, Div 2, GPS ABCD, T6...T2	
NI: CL II,III Div 2, GPS EFG, T6...T3B	
DIP: CL II, Div 1, GPS EFG, T6...T3B	
DIP: CL III, Div 1,2, T6...T3B	
CL I, ZN 2, AEx ec IIC T6...T2 Gc	
ZN 21, AEx tb IIIC T85°C...T165°C Db	
See handbook for temperature class information	

FM (marking for Canada)

Certificate	FM19CA0055X
NI: CL I, Div 2, GPS ABCD, T6...T2	
NI: CL II,III Div 2, GPS EFG, T6...T3B	
DIP: CL II, Div 1, GPS EFG, T6...T3B	
DIP: CL III, Div 1,2, T6...T3B	
CL I, ZN 2, Ex ec IIC T6...T2 Gc	
Ex tb IIIC T85°C...T165°C Db	
ANSI/ISA 12.27.01: Dual Seal	

Designation for model FMT2xx-F1... in Division 1

FM (marking for US)	
Certificate	FM19US0110X
XP-IS: CL I, Div 1, GPS BCD, T6...T2	
DIP: CL II,III, Div 1, GPS EFG, T6...T3B	
CL I, ZN 1, AEx db ia IIB+H2 T6...T2 Ga/Gb	
ZN21, AEx ia tb IIIC T85°C...T165°C Db	
Permitted supply short-circuit current: 35A	
See handbook for temperature class information and installation drawing 3kxf000094G0009	
FM (marking for Canada)	
Certificate	FM19CA0055X
XP-IS: CL I, Div 1, GPS BCD, T6...T2	
DIP: CL II,III, Div 1, GPS EFG, T6...T3B	
CL I, ZN 1, Ex db ia IIB+H2 T6...T2 Ga/Gb	
Ex ia tb IIIC T85°C...T165°C Db	
IN-/OUTPUTS: Urated=30V	
Ex ia INTRINSICALLY SAFE	
SECURITE INTRINSEQUE	

... Use in potentially explosive atmospheres

Ex marking pipe components and integrated hot tap fitting

Note

- A specific marking applies, depending on the design.
- ABB reserves the right to modify the Ex-marking. Refer to the name plate for the exact marking.

ATEX, IECEx and UKEX

Model number for use in Zone 2, 22	Ex marking	Certificate
FMT091_ (j=SCA, SCB, SCC) SensyMaster FMT091 pipe component type 1, wafer type Optional with ball valve or integrated hot tap fitting	II 3 G Ex h IIC T6...T3 Gc II 3 D Ex h IIIC T85°C ... T150°C Dc	ATEX: FM19ATEX0178X IECEX: IECEX FMG 19.0025X
FMT092_ (j=SCA, SCB, SCC) SensyMaster FMT092 pipe component type 2, partial measuring section Optional with ball valve or integrated hot tap fitting		UKEX: FM21UKEX0136X
FMT094_ (j=SCA, SCD) SensyMaster FMT094 pipe component type 4, partial measuring section Optional with ball valve or integrated hot tap fitting		

Model number for use in Zone 0/1, 21	Ex marking	Certificate
FMT091_ (j=SCA, SCB, SCC) SensyMaster FMT091 pipe component type 1, wafer type	II 2 G Ex h IIC T6...T3 Gb II 2 D Ex h IIIC T85°C ... T150°C Db	ATEX: FM19ATEX0177X IECEX: IECEX FMG 19.0025X
FMT092_ (j=SCA, SCB, SCC) SensyMaster FMT092 pipe component type 2, partial measuring section		UKEX: FM21UKEX0135X
FMT094_ (j=SCA, SCD) SensyMaster FMT094 pipe component type 4, partial measuring section Optional with ball valve or integrated hot tap fitting		

Notice regarding the integrated hot tap fitting

The integrated hot tap fitting has been designed in accordance with the DIN EN 80079-36 and DIN EN 80079-37 standards and the 'c – constructional safety' type of protection.

cFMus

The pipe components do not have any marking in accordance with cFMus. The pipe components can be used in accordance with cFMus in the following areas:

- Div. 1
- Div. 2, Zone 1, 2, 21

Temperature data

Temperature resistance for the connecting cable

The temperature at the cable entries of the device is dependent on the measuring medium temperature T_{medium} and the ambient temperature $T_{\text{amb.}}$.

For the electrical connection of the device, use only cables with sufficient temperature resistance in accordance with the following table.

$T_{\text{amb.}}$	Temperature resistance for the connecting cable
$\leq 50\text{ °C}$ ($\leq 122\text{ °F}$)	$\geq 70\text{ °C}$ ($\geq 158\text{ °F}$)
$\leq 60\text{ °C}$ ($\leq 140\text{ °F}$)	$\geq 80\text{ °C}$ ($\geq 176\text{ °F}$)
$\leq 70\text{ °C}$ ($\leq 158\text{ °F}$)	$\geq 90\text{ °C}$ ($\geq 194\text{ °F}$)

From an ambient temperature of $T_{\text{amb.}} \geq 60\text{ °C}$ ($\geq 140\text{ °F}$), the wires in the connection boxes with the enclosed silicone hoses need to be additionally insulated.

Note

The signal cable supplied by ABB can be used without restrictions up to an ambient temperature of $\leq 80\text{ °C}$ ($\leq 176\text{ °F}$).

Environmental and process conditions for model FMT2xx...

Ambient temperature $T_{\text{amb.}}$	-20 to 70 °C (-4 to 158 °F) -40 to 70 °C (-40 to 158 °F)*
Measuring medium temperature T_{medium}	-20 to 150 °C (-4 to 302 °F) -40 to 150 °C (-40 to 302 °F)*
IP rating / NEMA rating	IP 65, IP 67 / NEMA 4X, Type 4X

* Low temperature design (optional)

... Use in potentially explosive atmospheres

Measuring medium temperature (Ex data) for model FMT2x0-A1... in Zone 1, Zone 21

The table shows the maximum permissible measuring medium temperature as a function of ambient temperature and temperature class. The permissible measuring medium temperature specified in **Environmental and process conditions for model FMT2xx...** on page 33 must not be up-scaled!

Ambient temperature T _{amb.}	Temperature class					
	T1	T2	T3	T4	T5	T6
-40 °C to 40 °C (-40 °F to 104 °F)	280 °C (536 °F)	185 °C (365 °F)	90 °C (194 °F)	90 °C (194 °F)	—	—
-40 °C to 50 °C (-40 °F to 122 °F)	280 °C (536 °F)	185 °C (365 °F)	90 °C (194 °F)	90 °C (194 °F)	—	—
-40 °C to 60 °C (-40 °F to 140 °F)	280 °C (536 °F)	185 °C (365 °F)	90 °C (194 °F)	90 °C (194 °F)	—	—
-40 °C to 70 °C (-40 °F to 158 °F)	280 °C (536 °F)	185 °C (365 °F)	90 °C (194 °F)	90 °C (194 °F)	—	—

Measuring medium temperature (Ex data) for model FMT2x0-A2... in Zone 2, Zone 22

The table shows the maximum permissible measuring medium temperature as a function of ambient temperature and temperature class. The permissible measuring medium temperature specified in **Environmental and process conditions for model FMT2xx...** on page 33 must not be up-scaled!

Ambient temperature T _{amb.}	Temperature class					
	T1	T2	T3	T4	T5	T6
-40 °C to 40 °C (-40 °F to 104 °F)	300 °C (572 °F)	290 °C (554 °F)	195 °C (383 °F)	130 °C (266 °F)	95 °C (203 °F)	80 °C (176 °F)
-40 °C to 50 °C (-40 °F to 122 °F)	300 °C (572 °F)	290 °C (554 °F)	195 °C (383 °F)	130 °C (266 °F)	95 °C (203 °F)	—
-40 °C to 60 °C (-40 °F to 140 °F)	300 °C (572 °F)	290 °C (554 °F)	195 °C (383 °F)	130 °C (266 °F)	—	—
-40 °C to 70 °C (-40 °F to 158 °F)	300 °C (572 °F)	290 °C (554 °F)	195 °C (383 °F)	130 °C (266 °F)	—	—

Measuring medium temperature (Ex data) for model FMT2x0-F1... in Class I Division 1 and Class II Division 1

The table shows the maximum permissible measuring medium temperature as a function of ambient temperature and temperature class. The permissible measuring medium temperature specified in **Environmental and process conditions for model FMT2xx...** on page 33 must not be up-scaled!

Ambient temperature T_{amb}	Temperature class					
	T1	T2	T3	T4	T5	T6
-40 °C to 40 °C (-40 °F to 104 °F)	280 °C (536 °F)	185 °C (365 °F)	90 °C (194 °F)	90 °C (194 °F)	—	—
-40 °C to 50 °C (-40 °F to 122 °F)	280 °C (536 °F)	185 °C (365 °F)	90 °C (194 °F)	90 °C (194 °F)	—	—
-40 °C to 60 °C (-40 °F to 140 °F)	280 °C (536 °F)	185 °C (365 °F)	90 °C (194 °F)	90 °C (194 °F)	—	—
-40 °C to 70 °C (-40 °F to 158 °F)	280 °C (536 °F)	185 °C (365 °F)	90 °C (194 °F)	90 °C (194 °F)	—	—

Measuring medium temperature (Ex data) for model FMT2x0-F1... in Class I Division 2 and Class II Division 2

The table shows the maximum permissible measuring medium temperature as a function of ambient temperature and temperature class. The permissible measuring medium temperature specified in **Environmental and process conditions for model FMT2xx...** on page 33 must not be up-scaled!

Ambient temperature T_{amb}	Temperature class					
	T1	T2	T3	T4	T5	T6
-40 °C to 40 °C (-40 °F to 104 °F)	300 °C (572 °F)	290 °C (554 °F)	195 °C (383 °F)	130 °C (266 °F)	95 °C (203 °F)	80 °C (176 °F)
-40 °C to 50 °C (-40 °F to 122 °F)	300 °C (572 °F)	290 °C (554 °F)	195 °C (383 °F)	130 °C (266 °F)	95 °C (203 °F)	—
-40 °C to 60 °C (-40 °F to 140 °F)	300 °C (572 °F)	290 °C (554 °F)	195 °C (383 °F)	130 °C (266 °F)	—	—
-40 °C to 70 °C (-40 °F to 158 °F)	300 °C (572 °F)	290 °C (554 °F)	195 °C (383 °F)	130 °C (266 °F)	—	—

... Use in potentially explosive atmospheres

Ambient and process conditions for pipe components and integrated hot tap fitting

Measuring medium temperature T_{medium}	Standard: -20 to 150 °C (-4 to 302 °F)
Ambient temperature T_{amb} for pipe components without ball valve or integrated hot tap fitting.	Standard: -20 to 70 °C (-4 to 158 °F), optional: -40 to 70 °C (-40 to 158 °F) Depending on the selected ambient temperature range (TA3/TA9) of the sensor and O-ring design.
Ambient temperature T_{amb} for pipe components with ball valve or integrated hot tap fitting	Standard: -20 to 70 °C (-4 to 158 °F)

(Sensor connection options: SCA, SCB, SCD)

Measuring medium temperature (Ex data) for pipe components and integrated hot tap fitting

The table shows the maximum permissible measuring medium temperature as a function of ambient temperature and temperature class. The permissible measuring medium temperature specified in the table above must not be up-scaled!

Ambient temperature T_{amb}	Options	Temperature class			
		T3	T4	T5	T6
-20 °C to 70 °C (-4 °F to 158 °F)	Pipe component without ball valve or integrated hot tap fitting	150 °C (302 °F)	135 °C (275 °F)	100 °C (212 °F)	85 °C (185 °F)
-40 °C to 70 °C (-40 °F to 158 °F)	Pipe component without ball valve or integrated hot tap fitting	150 °C (302 °F)	135 °C (275 °F)	100 °C (212 °F)	85 °C (185 °F)
-20 °C to 70 °C (-4 °F to 158 °F)	Pipe component with ball valve or integrated hot tap fitting	150 °C (302 °F)	135 °C (275 °F)	100 °C (212 °F)	85 °C (185 °F)

Integrated hot tap fitting – maximum surface temperature

The maximum surface temperature of the integrated hot tap fitting is 85 °C to 150 °C (185 °F to 302 °F) depending on the measuring medium temperature.

Electrical data

Modbus outputs and digital outputs

ATEX/IECEX model: FMT2xx-A1..., FMT2xx-A2..., FMT2xx-A3...

cFMus model: FMT2xx-F1..., FMT2xx-F2...

	Operating values		Type of protection									
	(general)		'Ex ec' / 'NI' (Zone 2, 22) (Div. 2, Zone 2)		'Ex e' / 'XP' (Zone 1, 21) (Div. 1, Zone 1)		'Ex ia' / 'IS' (Zone 1, 21) (Div. 1, Zone 1)					
	U_N [V]	I_N [mA]	U_N [V]	I_N [mA]	U_M [V]	I_M [mA]	U_O [V]	I_O [mA]	P_O [mW]	C_O [nF]	$C_{O,pa}$ [nF]	L_O [μH]
Outputs												
Modbus, active												
Terminals A / B	30	30	30	30	30	100	4,2	150	150	13900	—	20
							U_i [V]	I_i [mA]	P_i [mW]	C_i [nF]	$C_{i,pa}$ [nF]	L_i [μH]
							4,2	150	150	13900	—	20
Digital output DO1, passive												
Terminals 41 / 42	30	30	30	30	30	100	30	25	187	20	—	200
Digital output DO2, passive												
Terminals 51 / 52	30	30	30	30	30	100	30	25	187	20	—	200

All outputs are electrically isolated from each other and from the power supply.

Digital outputs DO1 / DO2 are not electrically isolated from each other. Terminals 42 / 52 have the same potential.

Special connection conditions

Note

If the protective earth (PE) is connected in the flowmeter's terminal box, you must ensure that no dangerous potential difference can arise between the protective earth (PE) and the potential equalization (PA) in areas with explosion risk.

Note

The safety requirements for intrinsically safe circuits in the EC type examination certificate of the device must be complied with.

The output circuits are designed so that they can be connected to both intrinsically-safe and non-intrinsically-safe circuits.

- Combining intrinsically safe and non-intrinsically safe circuits is not permitted.
- On intrinsically safe circuits, potential equalization should be established along the entire length of the cable used for the signal outputs.
- The rated voltage of the non-intrinsically safe circuits is $U_M = 30$ V.
- Intrinsic safety is preserved If the rated voltage $U_M = 30$ V is not up-scaled when connections are established to non-intrinsically safe external circuits.
- The information in **Changing the type of protection** in the operating instruction must be observed when changing the type of protection.

Use in hazardous areas in accordance with EAC TR-CU-012

Note

- An additional document with information on EAC-Ex certification is available for measuring systems that are used in potentially explosive atmospheres in accordance with EAC TR-CU-012.
- The information on EAC-Ex certification is an integral part of this instruction. As a result, it is crucial that the installation guidelines and connection values it lists are also observed.

The icon on the name plate indicates the following:



Information on EAC-Ex certification is available for free download at the following link. Alternatively simply scan the QR code.



<INF/FMT200/FMT400/EAC-Ex-X8>

Ordering Information

Note

For additional information on dependencies and restrictions, and for help on product selection, please refer to the Online ABB Product Selection Assistant (PSA) for flow rate at abb.com/flow-selector.

SensyMaster FMT230

Thermal Mass Flowmeter, for standard OEM applications

Base model	FMT230	XX	XX	X	X	XX	XX	XX	X
SensyMaster FMT230 Thermal Mass Flowmeter									
Explosion Protection Certification									
Without		Y0							
ATEX / IECEx (Zone 2 / 21)		A2							
ATEX / IECEx (Zone 1 / 21)		A1							
ATEX / IECEx (Zone (0) 1 / 21)		A3							
cFMus (Class 1 Div. 2 / Zone 2)		F2							
cFMus (Class 1 Div. 1 / Zone 1)		F1							
UKEX Zone 2 / 22		U2							
UKEX Zone 1 / 21		U1							
UKEX Zone (0) 1 / 21		U4							
Measuring Medium									
Air or other clean gas (One gas component only)					C1				
Gas mixtures with max. 23.5 Vol% O ₂ (eg. Natural gas or Biogas)					C2				
Oxygen / gas mixtures > 23.5 Vol% O ₂ , oil and grease-free, with O2 certificate (max. 150 °C / 302 °F)					P1				
Ammonia					H3				
Sensor Element Type / Temperature Range of Measuring Medium									
Standard ceramic sensor / Standard range -20 to 150 °C (-4 to 302 °F)					A				
Ceramic sensor elements / High temperature range -20 to 300 °C (-4 to 572 °F)					B				
Ceramic sensor elements / Low temperature range -40 to 150 °C (-40 to 302 °F)					E				
Mounting Length / Flowmeter Sensor Material									
120 mm (4.7 in) / AISI 316Ti SST (1.4571) (DN 25 to DN 125 [1 to 5 in])									1*
263 mm (10.4 in) / AISI 316Ti SST (1.4571) (DN 25 to DN 350 [1 to 14 in])									2*
425 mm (17 in) / AISI 316Ti SST (1.4571) (> DN 350 to DN 700 [> 14 to 28 in])									3*
775 mm (31 in) / AISI 316Ti SST (1.4571) (> DN 700 [> 28 in])									4*
Sensor Connection									
Flange DN 25, nominal pressure 4 MPa (40 bar, 580 psi)									D3
Compression fitting, stainless steel, nominal pressure 2 MPa (20 bar, 290 psi) (-40 to 150 °C (-40 to 302 °F)) (≥ DN80 (≥ 3 in))									G2
Thread DIN 11851, nominal pressure 1.6 MPa (16 bar, 232 psi) (-20 to 140 °C (-4 to 284 °F)) (-20 to 140 °C (-4 to 284 °F))									F1
Connection Design / Transmitter Housing Type / Transmitter Housing Material / Cable Glands									
Integral / Single compartment / Aluminium / 2 × M20 × 1.5									B1
Integral / Single compartment / Aluminium / 2 × NPT ½ in									B2
Integral / Single compartment / Stainless Steel / 2 × M20 × 1.5									T1
Integral / Single compartment / Stainless Steel / 2 × NPT ½ in									T2
Outputs									
MODBUS, 2 Digital outputs (passive) (No HART)									M2
Power Supply									
24 V DC, +/- 20 %									B

* Nominal size ranges when using flanged pipe components or weld-on adapters without ball valve

Continued on next page

... Ordering Information

Additional ordering information SensyMaster FMT230

Additional ordering information	XX	XX	XXX	XX	XXX	XX	XX	XXX	XX
SensyMaster FMT230 Thermal Mass Flowmeter									
Material Certificates									
Material monitoring with inspection certificate 3.1 acc. EN 10204	C2								
Declaration of compliance with the order 2.1 acc. EN 10204	C4								
Inspection certificate 3.1 acc. EN 10204 for visual, dimensional and functional test	C6								
Inspection certificate 3.1 acc. EN 10204 for positive material identification PMI	CA								
Inspection certificate 3.1 acc. EN 10204 for positive material identification PMI with material analysis	C5								
Additional Calibration Certificates									
Certificate of DAkkS calibration, 10 points, traceable acc. ISO / IEC 17025 (Former DKD certificate, based on reference conditions with air)	CH								
Declaration of compliance for calibration 2.1 acc. EN 10204	CM								
Other Usage Certifications									
DVGW Certificate (T _{amb} : -20 to 100 °C)			CGW						
UKCA conformity			CU1						
Documentation Language									
German				M1					
English				M5					
Western Europe Scandinavia				MW					
Eastern Europe				ME					
Configuration Type									
Parameters set to factory default					NC1				
Parameters set customer specific (e.g. function of the outputs, etc.)					NCC				
Calibration Type									
5-point calibration, standard measuring range, incl. factory certificate						R3			
5-point calibration, extended measuring range, incl. factory certificate (non Ex version only)						R4			
Device Identification Plate									
Stainless steel plate with TAG no.							T1		
Adhesive label with TAG no.							TC		
Ambient Temperature Range									
Extended -40 to 70 °C (-40 to 158 °F) (in preparation)								TA9	
Extended Diagnostic Options									
VeriMass Verification Software									

SensyMaster FMT250

Thermal Mass Flowmeter, for advanced OEM applications

Base model	FMT250	XX	XX	X	X	XX	XX	XX	X
SensyMaster FMT250 Thermal Mass Flowmeter									
Explosion Protection Certification									
Without		Y0							
ATEX / IECEx (Zone 2 / 21)		A2							
ATEX / IECEx (Zone 1 / 21)		A1							
ATEX / IECEx (Zone (0) 1 / 21)		A3							
cFMus (Class 1 Div. 2 / Zone 2)		F2							
cFMus (Class 1 Div. 1 / Zone 1)		F1							
UKEX Zone 2 / 22		U2							
UKEX Zone 1 / 21		U1							
UKEX Zone (0) 1 / 21		U4							
Measuring Medium									
Air or other clean gas (One gas component only)									C1
Gas mixtures with max. 23.5 Vol% O ₂ (eg. Natural gas or Biogas)									C2
Oxygen / gas mixtures > 23.5 Vol% O ₂ , oil and grease-free, with O ₂ certificate (max. 150 °C / 302 °F)									P1
Ammonia									H3
Sensor Element Type / Temperature Range of Measuring Medium									
Standard ceramic sensor / Standard range -20 to 150 °C (-4 to 302 °F)									A
Standard ceramic sensor / High temperature range -20 to 300 °C (-4 to 572 °F)									B
Ceramic sensor elements / Low temperature range -40 to 150 °C (-40 to 302 °F)									E
Mounting Length / Flowmeter Sensor Material									
120 mm (4.7 in) / AISI 316Ti SST (1.4571) (DN 25 to DN 125 [1 to 5 in])									1*
263 mm (10.4 in) / AISI 316Ti SST (1.4571) (DN 25 to DN 350 [1 to 14 in])									2*
425 mm (17 in) / AISI 316Ti SST (1.4571) (> DN 350 to DN 700 [> 14 to 28 in])									3*
775 mm (31 in) / AISI 316Ti SST (1.4571) (> DN 700 [> 28 in])									4*
Sensor Connection									
Flange DN 25, nominal pressure 4 MPa (40 bar, 580 psi)									D3
Compression fitting, stainless steel, nominal pressure 2 MPa (20 bar, 290 psi) (-40 to 150 °C (-40 to 302 °F)) (≥ DN80 (≥ 3 in))									G2
Thread DIN 11851, nominal pressure 1.6 MPa (16 bar, 232 psi) (-20 to 140 °C (-4 to 284 °F)) (-20 to 140 °C (-4 to 284 °F))									F1
Connection Design / Transmitter Housing Type / Transmitter Housing Material / Cable Glands									
Integral / Single compartment / Aluminium / 2 × M20 × 1.5									B1
Integral / Single compartment / Aluminium / 2 × NPT ½ in									B2
Integral / Single compartment / Stainless Steel / 2 × M20 × 1.5									T1
Integral / Single compartment / Stainless Steel / 2 × NPT ½ in									T2
Outputs									
Digital output 1 (passive), MODBUS (No HART)									M2
Power Supply									
24 V DC, +/-20 %									B

* Nominal size ranges when using flanged pipe components or weld-on adapters without ball valve.

... Ordering Information

Additional ordering information SensyMaster FMT250

Additional ordering information	XX	XX	XXX	XX	XXX	XX	XX	XX	XX	XXX	XX
SensyMaster FMT250 Thermal Mass Flowmeter											
Material Certificates											
Material monitoring with inspection certificate 3.1 acc. EN 10204	C2										
Declaration of compliance with the order 2.1 acc. EN 10204	C4										
Inspection certificate 3.1 acc. EN 10204 for visual, dimensional and functional test	C6										
Inspection certificate 3.1 acc. EN 10204 for positive material identification PMI	CA										
Inspection certificate 3.1 acc. EN 10204 for positive material identification PMI with material analysis	C5										
Additional Calibration Certificates											
Certificate of DAKKS calibration, 10 points, traceable acc. ISO / IEC 17025 (Former DKD certificate, based on reference conditions with air)		CH									
Declaration of compliance for calibration 2.1 acc. EN 10204		CM									
Other Usage Certifications											
DVGW Certificate (T _{amb} : -20 to 100°C)			CGW								
UKCA conformity			CU1								
Documentation Language											
German				M1							
English				M5							
Western Europe Scandinavia				MW							
Eastern Europe				ME							
Configuration Type											
Parameters set to factory default					NC1						
Parameters set customer specific (e.g. function of the outputs, etc.)					NCC						
Special Applications											
Filling application								PT			
Calibration Type											
7-point calibration, standard measuring range, incl. factory certificate								R2			
7-point calibration, extended measuring range, incl. factory certificate (non Ex version only)								R4			
Process gas calibration, up to two gas components, incl. factory certificate								RP			
Process gas calibration, gas mixtures with more than two gas components, incl. factory certificate								RM			
Device Identification Plate											
Stainless steel plate with TAG no.									T1		
Adhesive label with TAG no.									TC		
Ambient Temperature Range											
Extended -40 to 70 °C (-40 to 158 °F) (in preparation)										TA9	
Extended Diagnostic Options											
VeriMass Verification Software											

SensyMaster FMT091 Pipe component / Wafer Design (Type 1)

Base model	FMT091	X	XXX	XX	XX	XX	XX	XX
SensyMaster FMT091 Pipe component / Wafer Design (Type 1)								
Design								
Standard		S						
Nominal Diameter								
DN 40 (1½ in)			040					
DN 50 (2 in)			050					
DN 65 (2½ in)			065					
DN 80 (3 in)			080					
DN 100 (4 in)			100					
DN 125 (5 in)			125					
DN 150 (6 in)			150					
DN 200 (8 in)			200					
Process Connection								
Flanges DIN PN 40					D4			
Flanges ANSI / ASME B16.5 Class 150, Schedule 40 S					A1			
Flanges ANSI / ASME B16.5 Class 300, Schedule 40 S					A3			
Sensor Connection								
Flange DN 25, nominal pressure 4 MPa (40 bar, 580 psi) with centering pin						D3		
Measuring Medium								
Air or other clean gas (only one gas type)							C1	
Gas mixtures with max. 23.5 Vol% O ₂ (e.g. natural gas or biogas)							C2	
Oxygen / gas mixtures > 23.5 Vol% O ₂ , oil and grease-free, with O ₂ certificate (max. 150 °C / 302 °F)							P1	
Ammonia							H3	
Pipe Material								
Stainless steel AISI 316Ti (1.4571)								S2
Mounting Length of the Sensor								
263 mm (10.4 in)								L2
425 mm (17 in)								L3

Continued on next page...

... Ordering Information

Additional ordering information

Additional ordering information	XXX	XXX	XX
SensyMaster FMT091 Pipe component / Wafer Design (Type 1)			
Sensor Connection Options			
With ball valve (max. 150 °C / 302 °F)	SCA* **		
With integrated hot-tap fitting, for pipe component DN 50 to DN 80 (-20 to 150°C / -4 to 302°F)	SCB***		
With integrated hot-tap fitting, for pipe component DN 100 to DN 200 (-20 to 150°C / -4 to 302°F)	SCC***		
Sensor Connection Accessories			
DN 25 blind flange to close flowmeter sensor connection, material stainless steel AISI 316Ti (1.4571)		SBA	
Certificates			
Material monitoring with inspection certificate 3.1 acc. EN 10204			C2
Declaration of compliance with the order 2.1 acc. EN 10204			C4
Inspection certificate 3.1 acc. EN 10204 for visual, dimensional and functional test			C6
Inspection certificate 3.1 acc. EN 10204 for positive material identification PMI			CA
Inspection certificate 3.1 acc. EN 10204 for positive material identification PMI with material analysis			C5
Pressure test acc. AD2000			CB
Other Usage Certifications			
DVGW Certificate (T _{amb} : -20 to 100°C)			CGW
UKCA conformity			CU1

* Correct sensor length: For pipe component DN 40 to DN 100: h = 263 mm, from DN 125: h = 425 mm.

** Suitable for use in Zone 2 / Div. 2.

*** Suitable for use in Zone 1, Zone 2 (not Zone 0) / Div. 1, Div. 2.

SensyMaster FMT092 Pipe component, partial measuring section (type 2)

Max. 1,6 MPa (16 bar, 232 psi)

Base model	FMT092	X	XXX	XX	XX	XX	XX	XX
SensyMaster FMT092 Pipe component, partial measuring section (type 2)								
Design								
Standard		S						
Integrated flow straighteners		F						
Nominal Diameter								
DN 25 (1 in)			025					
DN 40 (1½ in)			040					
DN 50 (2 in)			050					
DN 65 (2½ in)			065					
DN 80 (3 in)			080					
DN 100 (4 in)			100					
DN 125 (5 in)			125					
DN 150 (6 in)			150					
DN 200 (8 in)			200					
Process Connection								
Flanges DIN PN 40					D4			
Flanges ANSI / ASME B16.5 Class 150, Schedule 40 S					A1			
Flanges ANSI / ASME B16.5 Class 300, Schedule 40 S					A3			
R-External thread 1.6 MPa (16 bar, 232 psi)					N6			
Sensor Connection								
Flange DN 25, nominal pressure 4 MPa (40 bar, 580 psi) with centering pin						D3		
Thread DIN 11851, nominal pressure 1.6 MPa (16 bar, 232 psi) with centering pin						F1		
Measuring Medium								
Air or other clean gas (only one type of gas)							C1	
Gas mixtures with max. 23.5 Vol% O ₂ (e.g. natural gas or biogas)							C2	
Oxygen / gas mixtures > 23.5 Vol% O ₂ , oil and grease-free, with O ₂ certificate (max. 150 °C / 302 °F)							P1	
Ammonia							H3	
Pipe Material								
Stainless steel AISI 316Ti (1.4571)							S2	
Steel S 235 (1.0037) galvanized							S3	
Mounting Length of the Sensor								
120 mm (4.7 in)								L1
263 mm (10.4 in)								L2

Continued on next page...

... Ordering Information

Additional ordering information

Additional ordering information	XXX	XXX	XX
SensyMaster FMT092 Pipe component, partial measuring section (type 2)			
Sensor Connection Options			
With ball valve (max. 150 °C / 302 °F)	SCA* **		
With integrated hot-tap fitting, for pipe component DN 50 to DN 80 (-20 to 150°C / -4 to 302°F)	SCB***		
Sensor Connection Accessories			
DN 25 blind flange to close flowmeter sensor connection, material stainless steel AISI 316Ti (1.4571)		SBA	
Blind screw connection for Thread DIN 11851, to close flowmeter sensor connection, material stainless steel AISI 304 (1.4301)		SBB	
Certificates			
Material monitoring with inspection certificate 3.1 acc. EN 10204			C2
Declaration of compliance with the order 2.1 acc. EN 10204			C4
Inspection certificate 3.1 acc. EN 10204 for visual, dimensional and functional test			C6
Inspection certificate 3.1 acc. EN 10204 for positive material identification PMI			CA
Inspection certificate 3.1 acc. EN 10204 for positive material identification PMI with material analysis			C5
Other Usage Certifications			
DVGW Certificate (T _{amb} : -20 to 100°C)			CGW
UKCA conformity			CU1

* Correct sensor length: For pipe component DN 50 to DN 100: h = 263 mm, from DN 125: h = 425 mm.

** Suitable for use in Zone 2 / Div. 2.

*** Suitable for use in Zone 1, Zone 2 (not Zone 0) / Div. 1, Div. 2.

SensyMaster FMT094 Pipe component, weld-on adapter

Base model	FMT094	X	XXX	XX	XX	XX	XX	XX
SensyMaster FMT094 Pipe component, weld-on adapter								
Design								
Standard		S						
Nominal Diameter								
Selection for weld-on adapter			000					
Process Connection								
Selection for weld-on adapter				W2				
Sensor Connection								
Flange DN 25, nominal pressure 4 MPa (40 bar, 580 psi) with centering pin						D3		
Compression fitting, stainless steel, nominal pressure 2 MPa (20 bar, 290 psi)						G2		
Thread DIN 11851, nominal pressure 1.6 MPa (16 bar, 232 psi) with centering pin						F1		
Measuring Medium								
Air or other clean gas (only one gas type)							C1	
Gas mixtures with max. 23.5 Vol% O ₂ (e.g. natural gas or biogas)							C2	
Oxygen / gas mixtures > 23.5 Vol% O ₂ , oil and grease-free, with O ₂ certificate (max. 150 °C / 302 °F)							P1	
Ammonia							H3	
Pipe Material								
Stainless steel AISI 316Ti (1.4571)								S2
Carbon steel S 235 (1.0037)								C1
Mounting Length of the Sensor								
120 mm (4.7 in)								L1
263 mm (10.4 in)								L2
425 mm (17 in)								L3
775 mm (31 in)								L4

Continued on next page...

... Ordering Information

Additional ordering information SensyMaster FMT094

Additional ordering information	XXX	XXX	XX
SensyMaster FMT094 Pipe component, weld-on adapter			
Sensor Connection Options			
With ball valve (max. 150 °C / 302 °F)	SCA* **		
With integrated hot-tap fitting, with weld on adapter for diameter DN 100 to DN 300 (4 to 12 in) (-20 bis 150°C / -4 bis 302°F)	SCD***		
Sensor Connection Accessories			
DN 25 blind flange to close flowmeter sensor connection, material stainless steel AISI 316Ti (1.4571)		SBA	
Blind screw connection for Thread DIN 11851, to close flowmeter sensor connection, material stainless steel AISI 304 (1.4301)		SBB	
Certificates			
Material monitoring with inspection certificate 3.1 acc. EN 10204			C2
Declaration of compliance with the order 2.1 acc. EN 10204			C4
Inspection certificate 3.1 acc. EN 10204 for visual, dimensional and functional test			C6
Inspection certificate 3.1 acc. EN 10204 for positive material identification PMI			CA
Inspection certificate 3.1 acc. EN 10204 for positive material identification PMI with material analysis			C5
Other Usage Certifications			
DVGW Certificate (T _{amb} : -20 to 100°C)			CGW
UKCA conformity			CU1

* Correct sensor length: For pipe component DN 50 ... DN 100: h = 263 mm, from DN 125: h = 425 mm.
For weld-on adapter up to 150 mm: h = 263 mm, up to 500 mm: h = 425 mm, > 500 mm: h = 775 mm

** Suitable for use in Zone 2 / Div. 2.

*** Suitable for use in Zone 1, Zone 2 (not Zone 0) / Div. 1, Div. 2.

Questionnaire

Customer:	Date:
Ms. / Mr.:	Department:
Telephone:	Email:

Model:

FMT230 FMT430 Not determined
 FMT250 FMT450

Application data:

Operating pressure min. / norm. / max. [bar abs, psi, other] _____ Temperature min. / norm. / max. [°C, °F] _____

Flow rate min. / norm. / max. [kg/h, lbs/h, Nm³/h, other] _____ Normal conditions (in volume flow)

0°C, 1013mbar other
 20°C, 1013mbar

Gas data:

Gas type (pure gas): _____

Gas mixture (name, vol. %) ¹	Component 1	Component 2	Component 3	Component 4	Component 5
_____	_____	_____	_____	_____	_____

Transmitter design

Design: Signal cable length (remote mount design) Communication:

Integral mount design Single-compartment housing 5 m 25 m current output / HART
 Remote mount design Dual-compartment housing 15 m Modbus RTU

Piping / pipe component

Nominal diameter / pressure rating [DIN / ASME] _____ Inside diameter [mm] _____

Pipe component design

wafer type FMT091
 Partial measuring section FMT092
 Welding adapter FMT094

* In case of mixed gases the composition must be specified by stating the components: CH₄ 90 %, C₂H₆ 5 %, N₂ 3 %, C₃H₈ 1 %, CO₂ 1 %

Note

The order can only be confirmed and a delivery date specified once full technical clearance has been obtained!

Trademarks

Modbus is a registered trademark of Schneider Automation Inc.

Kalrez and Kalrez Spectrum are registered trademarks of DuPont

Performance Elastomers.

Sales



Service





ABB Measurement & Analytics

For your local ABB contact, visit:
www.abb.com/contacts

For more product information, visit:
www.abb.com/flow

We reserve the right to make technical changes or modify the contents of this document without prior notice. With regard to purchase orders, the agreed particulars shall prevail. ABB does not accept any responsibility whatsoever for potential errors or possible lack of information in this document.

We reserve all rights in this document and in the subject matter and illustrations contained therein. Any reproduction, disclosure to third parties or utilization of its contents – in whole or in parts – is forbidden without prior written consent of ABB.