



ELR: ABB range of front panel residual current relays  
Protection device according to IEC/EN 60947-2 Annex M

Power and productivity  
for a better world™



# Tested, certified, reliable

## Network monitoring and protection

The electronic residual current relays allow monitoring and protection of the low voltage distribution network through the use of a toroidal transformer. Protection is achieved in combination with the MCBs and MCCBs.

Compliance with protection standard IEC/EN 60947-2 Annex M allows to offer a cumulative operational time (residual current relay, shunt-trip, circuit breaker) guaranteed by the manufacturer. The new ABB ELR front panel residual current relays are tested for this purpose.

### Carrying out the protection

Thanks to the residual current relays it is possible to measure the leakage current to earth. These relays work in conjunction with a separate external toroid. The active conductors that pass through the toroid create a magnetic field proportional to the current flow. Under normal conditions and in the absence of leakage current, the vector sum of the current is zero. Any fault condition causes an unbalance in the vector sum proportional to the value of the leakage current. The value of the fault current is constantly detected by the toroid: when the residual current relay receives a signal from the toroid, it switches its output contacts. Then the shunt-trip opens the circuit breaker.

### Compliance to IEC/ EN 60947-2 Annex M

When the product is in compliance with IEC/EN 60947-2 Annex M, the manufacturer is responsible for respecting operational times.

The new range of ELR products from ABB comply with IEC/EN 60947-2 Annex M and is tested within a configuration that includes residual current relay, toroid, shunt-trip, MCCB/MCB available in ABB offer.

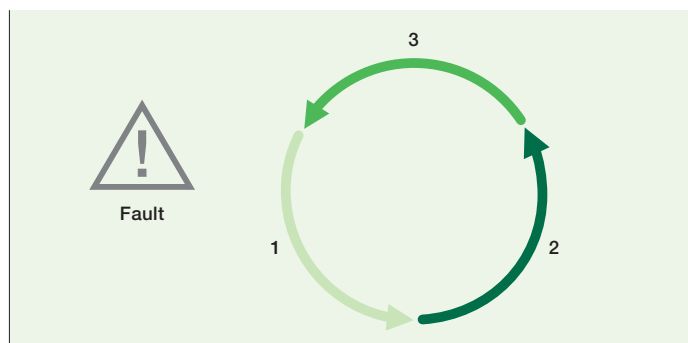

1. A residual current causes a flow unbalance detected by the toroid
2. The residual current relay receives the signal from the toroid and switches its output contacts
3. The shunt-trip relay opens the circuit breaker.



The new range of ELR front panel residual current relays has been tested in combination with miniature circuit breaker (S200 range) and moulded case circuit breakers (Tmax series up to T5 630 A) conforming with IEC/EN 60947-2 Annex M.

In order to ensure compliance to IEC/EN 60947-2 Annex M ABB has considered the following parameters:

**Operational time:** time that elapses between the occurrence of a fault and the intervention of the relay contacts

**Cumulative operational time:** time that elapses between the occurrence of a fault and the intervention (opening) of the associated circuit breaker.

**Non-operation time:** delay, adjustable on the device, which defines how long the fault should last before the relay contacts switch. This value is important to ensure selectivity and resistance to unwanted tripping of the associated circuit breaker.

# Completeness of the range

## Technical features



		ELR48P	ELR72	ELR72P
Operating voltage	V	ELR48P: 110 V a.c./d.c. 230 V a.c. (±20%) ELR48V24P: 24-48 V a.c./d.c. (±20%)	ELR72: 110 V a.c./d.c. 230 V a.c. (±20%) ELR72V24: 24-48 V a.c./d.c. (±20%)	ELR72P: 110, 230, 400 V a.c. (±20%) ELR72V24P: 24-48 V a.c./d.c. (±20%)
Frequency	Hz	50 – 60	50 – 60	50 – 60
Frequency filtering		-	-	-
Type		A	A	A
Operating temperature	°C	-10...+60	-10...+60	-10...+60
Power consumption	W	<7	<7	<7
Sensitivity adjustments $I_{\Delta n}$	A	from 0.03 to 30	from 0.03 to 30	from 0,03 to 30
Tripping time adjustments $\Delta t$	sec.	from 0 to 5	from 0 to 5	from 0 to 5
Number of contacts	n°	2	1	2
Contact capacity	A	5 (250 V a.c.)	5 (250 V a.c.)	5 (250 V a.c.)
Dimensions L x H	mm	48 x 48	72 x 72	72 x 72
Display		-	-	-
Protection degree		IP52 (front with cover) IP40 (front), IP20 (output contacts)	IP52 (front with cover) IP40 (front), IP20 (output contacts)	IP52 (front with cover) IP40 (front), IP20 (output contacts)
Standard		IEC/EN 60947-2 Annex M	IEC/EN 60947-2 Annex M	IEC/EN 60947-2 Annex M





	<b>ELR96</b>	<b>ELR96P</b>	<b>ELR96PF</b>	<b>ELR96PD</b>
	<b>ELR96:</b> 110 V a.c./d.c. 230, 400 V a.c. (±20%) <b>ELR96V24:</b> 24-48 V a.c./d.c. (±20%)	<b>ELR96P:</b> 110, 230, 400 V a.c. (±20%) <b>ELR96V24P:</b> 24-48 V a.c./d.c. (±20%)	<b>ELR96PF:</b> 110, 230, 400 V a.c. (±20%)	<b>ELR96PD:</b> 110, 230, 400 V a.c. (±20%)
	50 – 60	50 – 60	50 – 60	50 – 60
	-	-	YES	YES
	A	A	A	A
	-10...+60	-10...+60	-10...+60	-10...+60
	<7	<7	<7	<7
	from 0,03 to 30	from 0,03 to 30	from 0,03 to 30	from 0,03 to 30
	from 0 to 5	from 0 to 5	from 0 to 5	from 0 to 5
	1	2	2	2
	5 (250 V a.c.)	5 (250 V a.c.)	5 (250 V a.c.)	5 (250 V a.c.)
	96 x 96	96 x 96	96 x 96	96 x 96
	-	-	yes	yes
	IP52 (front with cover) IP40 (front), IP20 (output contacts)	IP52 (front with cover) IP40 (front), IP20 (output contacts)	IP52 (front with cover) IP40 (front), IP20 (output contacts)	IP52 (front with cover) IP40 (front), IP20 (output contacts)
	IEC/EN 60947-2 Annex M	IEC/EN 60947-2 Annex M	IEC/EN 60947-2 Annex M	IEC/EN 60947-2 Annex M

## Toroidal transformers

The choice of toroidal transformers is made according to the useful diameter and the minimum value of the leakage current to be detected.

**Table 1**

Type	Toroid useful diameter [mm]	Max rated current [A]	Min measurable current [mA]
TRM	29	65	30
TR1	35	75	30
TR2	60	85	30
TR3	80	160	100
TR4	110	250	100
TR4/A	110	250	300
TR160	160	400	300
TR160/A	160	400	500
TR5	210	630	300
TR5/A	210	630	500

Table 1 shows toroidal transformers selection for use with ELR according to IEC/ EN 60947-2 Annex M in combination with MCBs S200 range and MCCBs Tmax range up to T5.

**Table 2**

Type	Toroid useful diameter [mm]	Min measurable current [mA]	Maximum capacity [A]
TRM	29	30	160
TR1	35	30	250
TR2	60	30	400
TR3	80	100	800
TR4	110	100	1250
TR4/A	110	300	1250
TR160	160	300	2000
TR160/A	160	500	2000
TR5	210	300	3200
TR5/A	210	500	3200

Table 2 shows the technical features of the toroidal transformers.



# Compliance with standards, ongoing monitoring

## The features and benefits of the residual current relays

### Adjusting sensitivity and tripping times

The sensitivity  $I_{\Delta n}$  can be set from 0.03 to 30 A while the tripping times from 0 to 5 seconds, thus ensuring flexibility for many applications.

### Alarm

#### (72P and 96P versions only)

If the alarm function is ON, the alarm contact switches when the fault current exceeds 60% of the threshold  $I_{\Delta n}$  selected.

### Fail Safe

#### (P version only)

The new range of ELR residual current relays allows, through a selector switch, to enable or not the fail safe function. If Fail safe is OFF, the relay activates the shunt-trip once the fault current is detected and also when there is no connection between the relay and toroid.

If Fail Safe is ON, the relay activates the shunt-trip also when there is lack of supply to the residual current relay. The Fail Safe prevents the line from not being protected when there is no auxiliary power to the device.



### Remote reset

The output contacts of the ELR residual current relays can be reset remotely, using push-buttons.

### Autoreset

When the fault will be removed from the network, the relay contacts will switch automatically, without the need to press the reset button from a local or remote position.

### Frequency filtering (ELR96PF and ELR96PD versions only)

This feature makes the relay stronger in presence of currents with harmonic components that are not due to an effective fault in the circuit but they are typically caused by the presence of electronic filters (e.g. when using frequency converters driving motors).

### Fault Memory LED (ELR96PF version only)

The fault memory LED turns on in case of a fault and is only resettable manually. In this way it is possible to know if the relay has tripped even if the fault is no longer present and the contacts have returned into the standard position thanks to the autoreset.

### Digital display (ELR96PD version only)

The digital display allows instant reading of the value of earth leakage current. It is possible, through a minidip, to block the display on the residual current value that has generated the intervention of the circuit breaker.

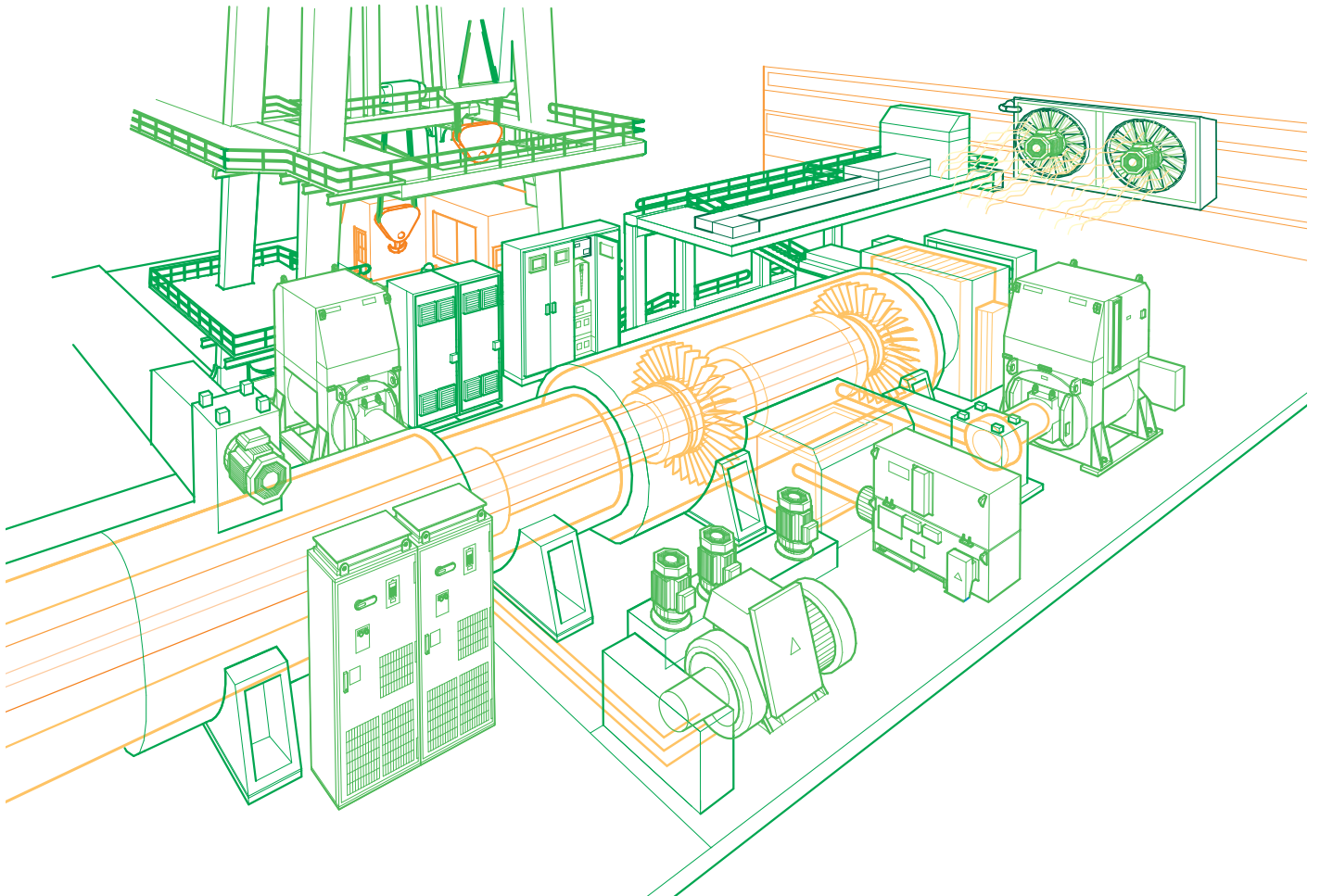

# Cutting-edge features

## ELR range details

### ELR72P

Minidip set-up: Alarm, multiplication constants of sensitivity and intervention time, Fail Safe (on both output contacts)

Sensitivity adjustment  $I_{\Delta n}$  (from 0.03 to 30A)

Test push-button

Reset push-button



Supply voltages  
110, 230, 400 V a.c. (ELR72P)  
or 24 - 48 V a.c./d.c. (ELR72V24P)

Blank space for identification of the residual current relay and the associated toroid and breaker

Intervention time adjustment  $\Delta t$



### ELR48P (48x48 mm)

As the other models it allows to adjust  $I_{\Delta n}$  (from 0.03 to 30 A) and intervention times (from 0 to 5 sec). It is equipped with test and reset buttons, 2 status LEDs and 2 contact outputs. Furthermore it is possible to set the reset logic (automatic or manual) and Fail Safe. The ELR48P version provides supply voltages of 110 V a.c./d.c. and 230 V a.c.; the ELR48V24P version operates from 24 to 48 V a.c./d.c.



### ELR72 (72x72 mm)

The device has 1 output contact. It is possible to set the reset in automatic or manual mode. The supply voltage can be 110 V a.c./d.c. and 230 V a.c. The ELR72V24 version provides supply voltages from 24 to 48 V a.c./d.c.



## ELR96PD

Green LED "ON": power on.  
Yellow LED "ALARM": trip of the alarm contact.  
Red LED "FAULT": trip of the fault contact.

The digital display shows instantaneously the leakage current  $I_{\Delta}$

Sensitivity adjustment  $I_{\Delta n}$  from 0.03 to 30 A

Test push-button

Blank space for identification of the residual current relay and the associated toroid and breaker

Intervention times from 0 to 5 seconds

Supply voltages 110, 230, 400 V a.c.

Minidip set-up: Alarm, multiplication constants of sensitivity and intervention time, Fail Safe (on both the output contacts)

Reset push-button

2 output contacts (trip and alarm)



### ELR96 (96x96 mm)

This model offers the possibility of adjusting  $I_{\Delta n}$  (from 0.03 to 30 A) and intervention times (from 0 to 5 sec). The most important functions of this device are: test push-button, reset push-button, status LEDs and output contact. It is possible to set the reset logic (automatic or manual). The supply is 110 V a.c./d.c., 230 and 400 V a.c.; the ELR96V24 version operates from 24 to 48 V a.c./d.c.



### ELR96P (96x96 mm)

This model has an "ALARM" LED (the fault current has exceeded 60% of the  $I_{\Delta n}$  selected), 2 contact outputs (trip and alarm) and the Fail Safe function can be set for both the contacts. The supply is 110 V a.c./d.c., 230 and 400 V a.c. or from 24 to 48 V a.c./d.c. (ELR96V24P). Trip, Alarm and Autoreset contacts are available, with the possibility of remote reset.



### ELR96PF (96x96 mm)

It has the same features as the ELR96, but it is provided with a LED light which turns on in the event of a trip and can only be reset manually. The frequency filtering function makes the product stronger against unwanted trippings due to faults with harmonic components. The supply voltage is 110, 230 or 400 V a.c.

# The new range of residual current relays

## Order codes and overall dimensions

### Order codes for residual current relays

Operating voltage	Description Type	Order code	Bbn 8012542 EAN	Unit weight [kg]
110 V a.c./d.c., 230 V a.c. ( $\pm 20\%$ )	ELR48P	2CSG252211R1202	748229	0.112
24-48 V a.c./d.c. ( $\pm 20\%$ )	ELR48V24P	2CSG452211R1202	734826	0.112
110 V a.c./d.c., 230 V a.c. ( $\pm 20\%$ )	ELR72	2CSG252120R1202	733928	0.322
24-48 V a.c./d.c. ( $\pm 20\%$ )	ELR72V24	2CSG452120R1202	747024	0.322
110, 230, 400 V a.c. ( $\pm 20\%$ )	ELR72P	2CSG152424R1202	734727	0.322
24-48 V a.c./d.c. ( $\pm 20\%$ )	ELR72V24P	2CSG452424R1202	733829	0.322
110, 230, 400 V a.c. ( $\pm 20\%$ )	ELR96	2CSG152130R1202	734628	0.383
24-48 V a.c./d.c. ( $\pm 20\%$ )	ELR96V24	2CSG452130R1202	733720	0.383
110, 230, 400 V a.c. ( $\pm 20\%$ )	ELR96P	2CSG152434R1202	734529	0.383
24-48 V a.c./d.c. ( $\pm 20\%$ )	ELR96V24P	2CSG452434R1202	733621	0.383
110, 230, 400 V a.c. ( $\pm 20\%$ )	ELR96PF	2CSG152435R1202	734420	0.383
110, 230, 400 V a.c. ( $\pm 20\%$ )	ELR96PD	2CSG152436R1202	733522	0.383

### Overall dimensions for residual current relays

#### ELR48P

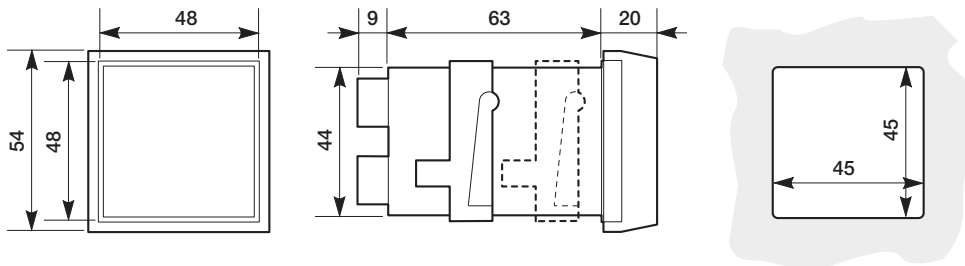

#### ELR72

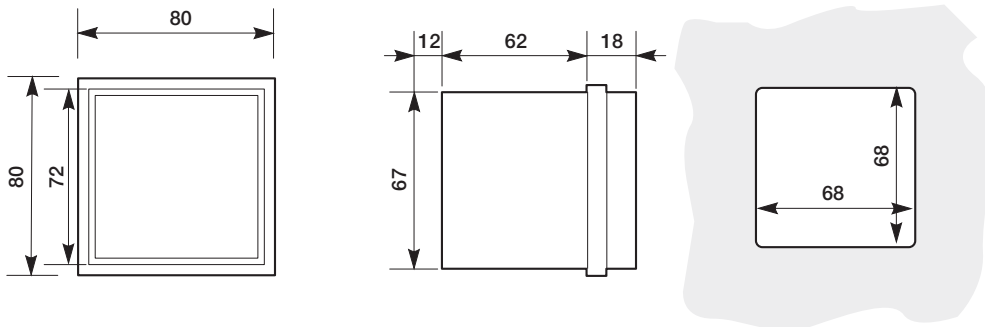

#### ELR96

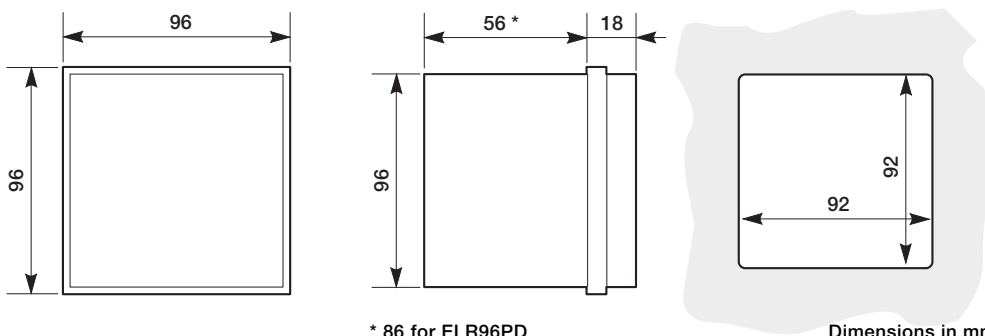

\* 86 for ELR96PD

Dimensions in mm

## Order codes for toroidal transformers

Dimensions (Internal diameter) [mm]	Description Type	Order code	Bbn 8012542 EAN	Unit weight [kg]
39 (modular version)	TRM	2CSM029000R1211	020707	0.170
35	TR1	2CSG035100R1211	020301	0.212
60	TR2	2CSG060100R1211	020400	0.274
80	TR3	2CSG080100R1211	020509	0.454
110	TR4	2CSG110100R1211	020608	0.530
160	TR160	2CSG160100R1211	743507	0.600
210	TR5	2CSG210100R1211	024804	1.350
110 (openable)	TR4/A	2CSG110200R1211	743408	1.600
160 (openable)	TR160 A	2CSG160200R1211	743606	1.534
210 (openable)	TR5/A	2CSG210200R1211	065708	1.856

## Overall dimensions for toroidal transformers

Type	Dimensions [mm]									
	A	B	C	D	E	F	G	H	K	
TR1	35	100	60	110	47	50	43	30	-	
TR2	60	100	60	110	47	50	43	30	-	
TR3	80	150	110	160	70	50	43	30	-	
TR4	110	150	110	160	70	50	43	30	-	
TR4A	110	145	110	150	75	45	38	25	180	
TR160	160	220	156	236	110	64	50	34	-	
TR160A	160	220	156	236	110	64	50	34	-	
TR5	210	310	240	290	145	260	280	36	55	
TR5A	210	310	240	290	145	260	280	36	55	

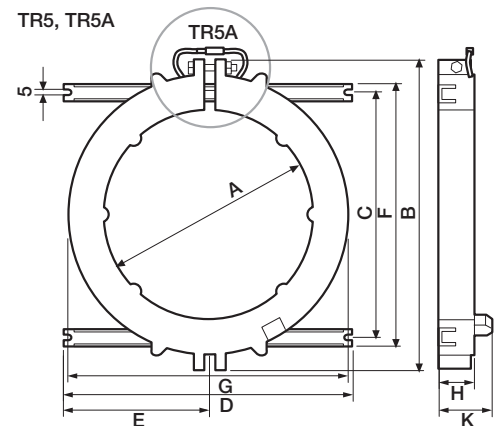
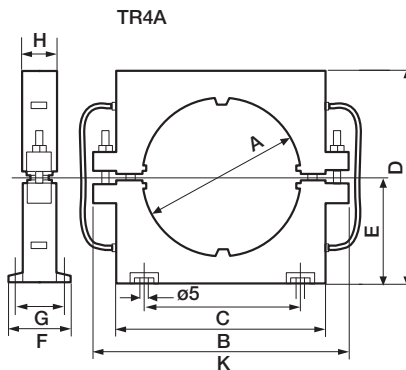
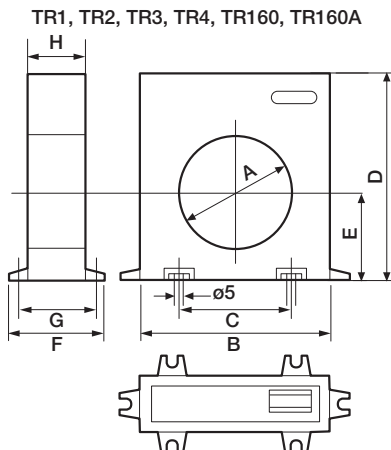
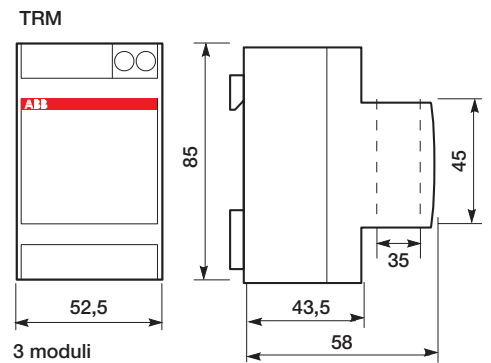

# Contacts

## **ABB SACE**

**A division of ABB S.p.A.  
Line Protection Devices**

Viale dell'Industria, 18  
20010 Vittuone (MI) - Italy  
Tel.: +39 02 9034 1  
Fax: +39 02 9034 7609

**[www.abb.com](http://www.abb.com)**

The data and illustrations are not binding. We reserve the right to modify the contents of this document on the basis of technical development of the products, without prior notice.

Copyright 2012 ABB. All rights reserved.

2CSC44050E0201 - 01/2012 - 2.000 Pz. - CAL