

SACO 16D1 Annunciator unit

User's manual and Technical description



Data subject to change without notice

Table of contents	Features	3
	General	3
	Area of applications	3
	Description of functions	4
	Introduction	4
	Mechanical construction	5
	Field contact circuits	6
	Alarm channel functions	6
	Visual alarm indication	8
	Standardized operational sequences	8
	First-out indication	10
	Event register	10
	Event register for the serial communication	11
	Auxiliary outputs	12
	Group alarm reflash signals	12
	Audible device output	13
	Self-supervision output	14
	Interlockings	15
	Serial communication interface	17
	Synchronizing of the blinking sequence	17
	Programming	18
	Auxiliary power supply system	18
	Application	19
	Mounting	19
	Terminals and wiring	20
	Start-up	21
	Operational test	21
	Legend plate	21
	Selection of output contact mode	22
	Operation instructions	23
	First-out alarm indication	24
	Event sequence register	25
	Programming	26
	Programming technique	26
	Programming push-buttons	28
	Channel related parameters	28
	Selection of channel input delay	28
	Selection of channel resetting delay	28
	Selection of field contact type or pulse counter	29
	Selection of channel-specified indications	29
	Configuration of pumping supervision	29
	Configuration of reflash group alarms	29
	Module related parameters	30
	Selection of mode of operation for the reflash output relays	30
	Selection of interlocking configuration	30
	Selection of annunciator SPA bus slave address	31
	Selection of alarm sequence type	31
	Selection for the serial communication port	32
	Parameter selection key	33
	Parameter chart	34
	Channel interlocking scheme	35
	Remote information to and from the alarm annunciator	36
	Event codes	40
	Technical data	40
	Testing	42
	Maintenance and repair	42
	Exchange and spare parts	43

Features	SACO 16 D1 is a self-contained microprocessor based multi channel alarm annunciator unit	Numerical display for first out alarm indication, event sequence reporting and programming
	16 contact operated on/off alarm or pulse counting channels per unit	Event register for the 50 latest events
	Four output relays of which two user configurable	Serial communication interface for easy connection of the annunciator unit to a monitoring and/or control system.
	Relay output for audible alarm and self supervision	Improved system reliability backed up by a sophisticated self-supervision function comprising both hardware and software watchdog functions
	LEDs for visual alarm indication	High immunity against electrical interference and an enclosure to IP 54 when panel mounted
	Fully programmable by means of push-buttons on the front panel or via the serial communication interface	

General

The alarm annunciator unit type SACO 16D1 is a part of the integrated substation secondary equipment system SPACOM.	field contact voltage, which also is used in the external acknowledge/reset circuits. Thus no separate power units are needed for the field contact circuits.
The on/off annunciator unit is a fully self-contained compact microprocessor based device suitable for use as stand-alone annunciator, but also as data acquisition, recording or control unit, either stand-alone or integrated into a system.	The microprocessor module is a standardized 100 mm x 160 mm Euro-card printed circuit board (PCB) which also functions as the basic element in large alarm annunciator systems mechanically designed according to the 19 inch rack and cabinet system (SACO 64D4).
The annunciator unit is provided with 16 channels for operation from NO or NC field contacts. The unit is furthermore provided with four auxiliary output relays, one for control of an audible device (horn, buzzer etc.), one is controlled by the internal self-supervision system and two for general retransmission of individual or group alarm signals. The unit is also provided with two control inputs for external acknowledge and reset functions. The alarm annunciator unit is fully self-contained including an integral power supply unit generating the internal supply voltages as well as the external	The modern microprocessor technology used in the SACO system offers new features which not only extend the conventional area of application for alarm annunciator systems but also increase the reliability of the annunciator systems. The most significant feature of the new annunciator system is the outstanding system flexibility. The annunciator is truly field programmable by means of push-buttons on the front panel, or from a PC via the serial communication, for easy selection of a proper operational scheme and suitable parameter values in the intended application.

Area of application

The annunciator unit SACO 16D1 has been developed and manufactured to meet the most demanding specifications regarding reliability in operation and immunity against interference which can be expected from a modern annunciator system for use in:	Furthermore the annunciator system can be used in any conventional application where there is a demand for a continuous supervision or monitoring of a number of contacts to provide an immediate fault recognition, fault identification and a visual/audible alarm in order to call attention to an abnormal process condition or as a pulse counter for change of state of a process parameter under normal process conditions.
<ul style="list-style-type: none"> - electric power plants and substations - industrial plants and processes - marine vessels and off-shore installations - technical installations in buildings - water treatment plants, etc. 	

Description of functions

Introduction

The annunciator unit SACO 16D1 is a flexible and versatile annunciator package comprising 16 input alarm channels. Its main purpose is to supervise a given process and to call attention to abnormal process conditions by the use of individual visual LED indicators and a common audible device. The annunciator system can also be connected to an event recorder system, by means of which printed records with channel identification, date and time, are obtained whenever a change in the state of an alarm channel occurs.

The basic functions of the annunciator unit are illustrated in the block diagram below.

The alarm channel inputs are connected to the field contacts. The field contacts, i.e. the output contacts of the devices sensing the process condition can be of the normally open (NO) or the normally closed (NC) type.

The central unit continually compares incoming channel information with previously stored information. When a change of state has been detected, the alarm channel is activated and if the situation persists for a longer time than the specified channel input delay time, the event will be registered. The visual indicators and the auxiliary output relays respond to the situation according to the functional program they have been given.

The annunciator unit can be acknowledged and reset with a push-button on the front panel or by means of external remote push-buttons.

The annunciator unit comprises an internal event register. The unit is provided with a serial communication interface and thus it can be connected to a local data collector, e.g. a SRIO 500M/1000M, by means of a serial communication link. The information stored in the event register of the annunciator unit can be read out via the serial communication link.

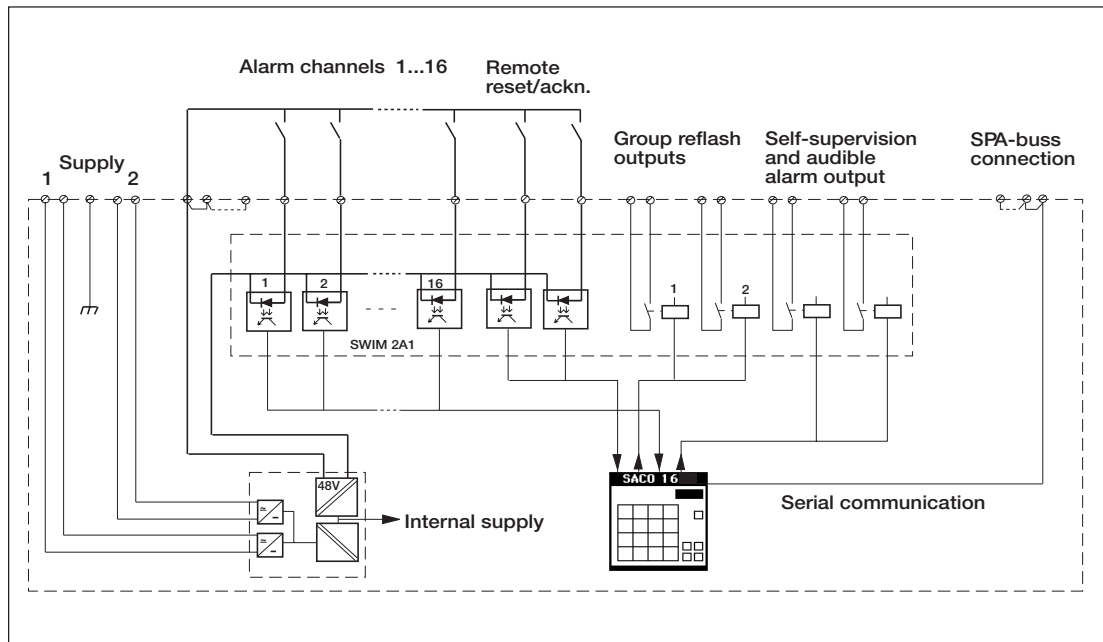

Fig. 1. Block schematic diagram for the annunciator unit SACO 16D1.

The annunciator unit is composed of standardized 100 mm x 160 mm "Euro-card" plug-in modules. An annunciator unit type SACO 16D1 consists of the following modules:

- a power supply module type SPGU 240A1 or SPGU 48B2
- an Input/Output module type SWIM 2A1
- an alarm annunciator module type SWPM 3A1

The enclosure of the annunciator module consists of an extruded aluminum profile to which the connection module SWCM 3A1 has been fixed to form the mounting case. The connection module comprises the plug-in PCB connectors and the screw terminals to facilitate all external connections. The connection module also comprises a 48 V dc power unit for voltage supply to the field contact circuits.

The annunciator unit is intended for flush mounting. The depth behind the panel can be

reduced by 40, 80 or 120 mm by using a raising frame.

The cast aluminum alloy mounting frame is stove-finished with a beige semi gloss carbamide resin paint and provided with a rubber gasket which provides a degree of protection by enclosure to IP 54 between the mounting case and the panel .

The mounting case is also provided with a glass-clear UV-stabilized polycarbonate lid with a sealable locking screw. The lid also has an IP 54 classification when closed with the finger screw.

The screw terminal blocks to facilitate all input and output wire connections are located on the back of the mounting case. One or two max. 2.5 mm² conductors can be connected to each terminal. No terminal lugs are needed. A connection diagram is shown on one of the sides of the case.

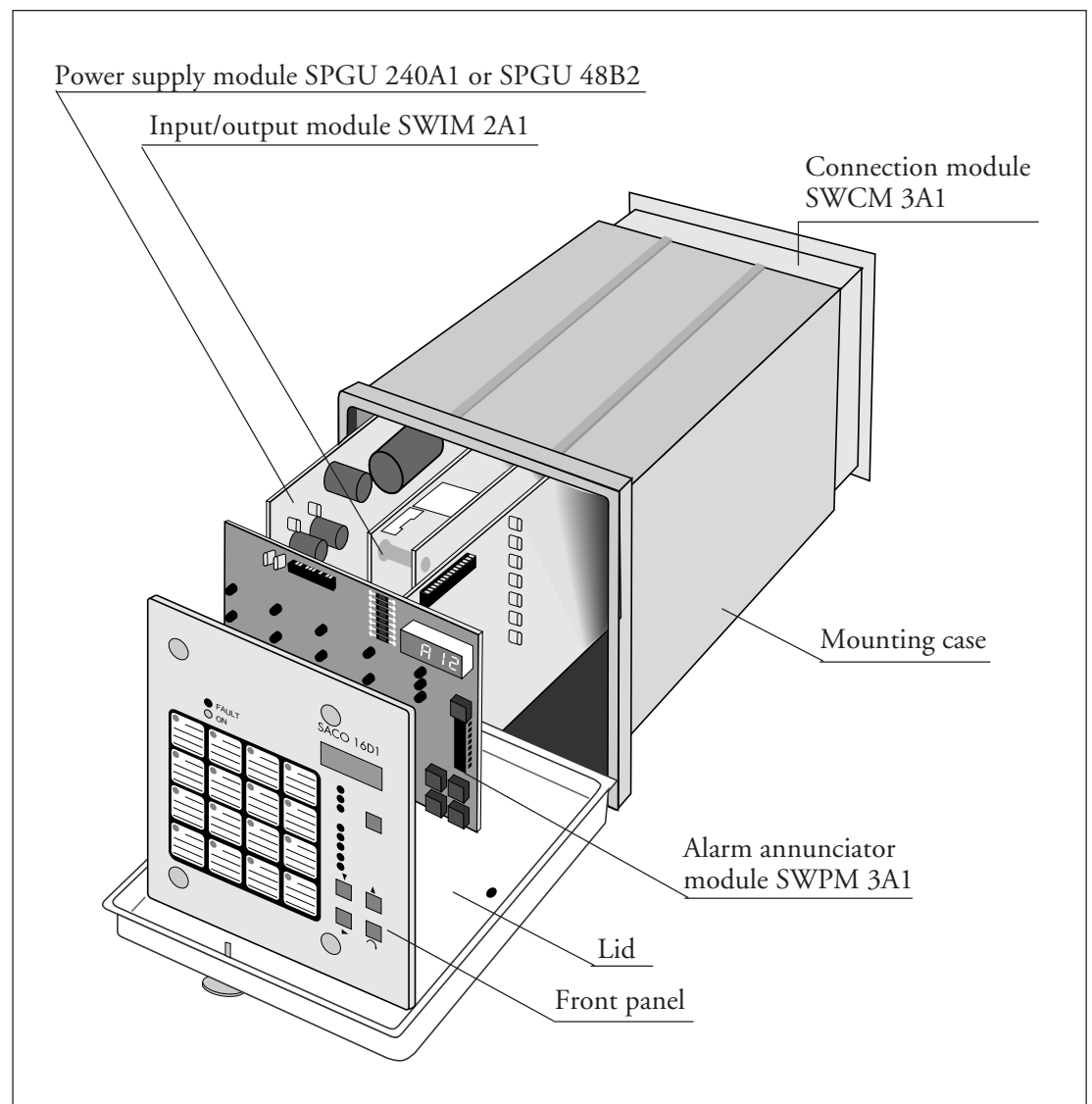

Fig. 2. Plug-in modules of the annunciator unit SACO 16D1.

Field contact circuits

The electrical contacts of the devices sensing the process condition must be potential-free while the annunciator unit itself generates the 48 V dc field contact voltage. This specification also applies to the remote control inputs.

The power unit supplying voltage to the field contacts also provides a full galvanic isolation between the field contact circuits and the electronic circuits of the annunciator unit itself as well as the system earth. The channel inputs are provided with transient suppression circuits and input voltage limiters.

The alarm channels can be individually programmed for operation from normally closed (NC) or from normally open (NO) contacts. The annunciator is provided with an integrated field contact voltage supervision function. When a fault is detected the LED indicator marked "FAULT" on the front panel is switched on and internal supervision output relay operates. The fault message can also be transmitted over the serial communication link to the higher system levels.

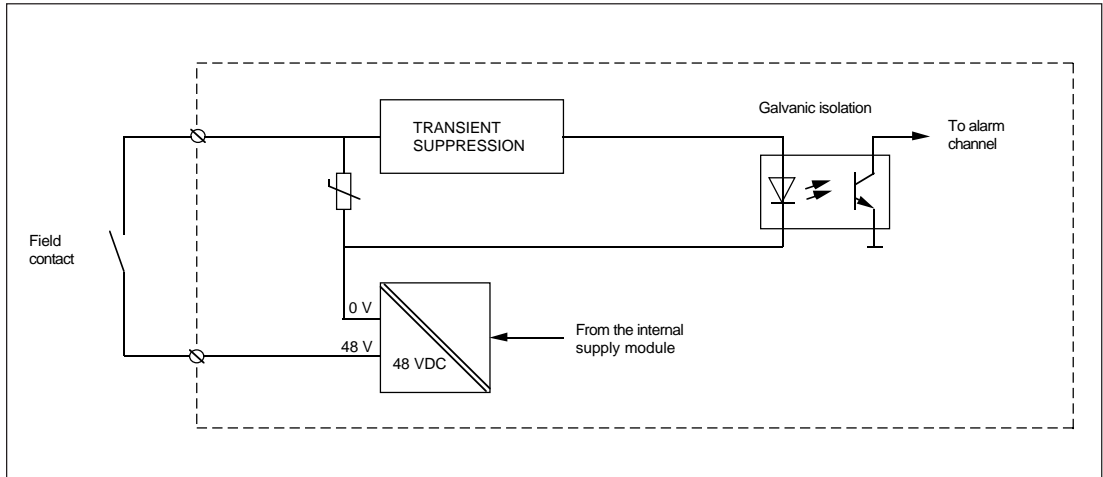

Fig. 3. Principle of alarm channel input.

Alarm channel functions

An alarm channel is composed of a number of functional blocks illustrated below. The lists of variables underneath some of the blocks indicate that a certain parameter can be selected

from a set of given values, i.e. the parameter can be programmed. The selected parameter is shown in the numerical display when called up during the programming.

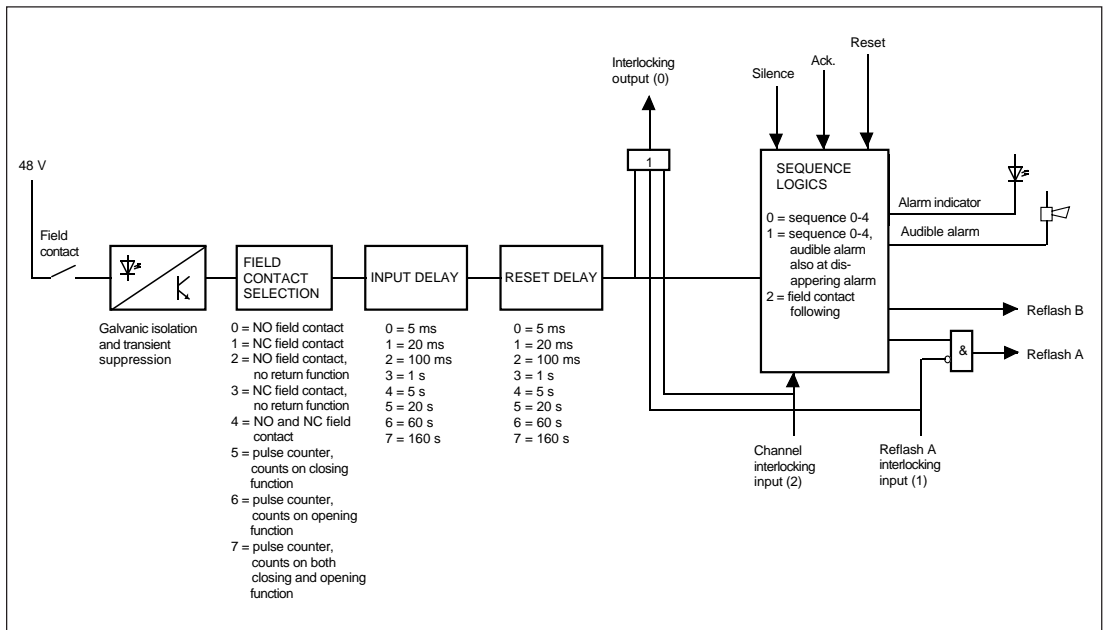

Fig. 4. Block schemating diagram for an alarm channel.

After the galvanic separation and the transient suppression the incoming field contact signal is analyzed and identified in respect of signal type. Seven input signal types are specified:

- 0 = signal from normally open contact, with return function
- 1 = signal from normally closed contact, with return function
- 2 = signal from raising edge only
- 3 = signal from falling edge only
- 4 = signal from raising and the falling edge
- 5 = pulse counter, counts by contact closing
- 6 = pulse counter, counts by contact opening
- 7 = pulse counter, counts by contact opening and closing

The input signal types 2, 3 and 4 are usually selected when event recording is used. For example the signal indicating that a circuit breaker has tripped is noticed and registered with its raising edge only.

The pulse counter is used only when the data is transferred to a higher level system. The pulse counter channels sequence logic is to be set to signal following without blinking and audible alarm functionality (S4 = 2). The reflash relays connected to the pulse counter channels are to be configured as ISR, Impulse Shaping Reflash (S1 or S2 = 2).

The channels configured as pulse counters counts pulses up to 3 Hz. The capacity of the counter is 0...29999. The counter is freely presettable within this range. When the pulse counter reaches 29999 it starts over again from 0.

The counter can be read and set only via the SPA bus with the channel specific parameter V5. When the parameter V5 is read the present value of the pulse counter is received, when written the preset (start) value for the pulse counter is given.

The counters memory circuit has no battery backup, hence the stored values are lost if the auxiliary power drops off and the counter starts over again from 0 or its preset value when the auxiliary power returns.

When a change of status has been detected for an incoming field contact signal and the new status exceeds the channel input delay in duration, the operation sequence memory is activated.

The channel input delay can be selected from a set of eight alternative values from the front panel:

- 0 = 5 ms
- 1 = 20 ms
- 2 = 100 ms

3 = 1 s

4 = 5 s

5 = 20 s

6 = 60 s

7 = 160 s

8 = another value, which is programmed via the serial interface

Via the serial interface the channel input delay can be freely programmed. Refer to the parameter list in the end of this manual (S1).

If the change-of-status of a field contact signal means that the signal returns to normal, the channel reset delay time must be exceeded before the change is registered. The delay time alternatives are the same as those for the input delay but the channel reset delay times are selected separately (S2).

When the operation sequence logic circuits are activated, the visual alarm displays start functioning according to the programmed operational sequence (flash sequence). The most suitable of five standard operational sequences is chosen by programming. All changes of status of the incoming signals are stored in the event register irrespective of the selected operational sequence for the visual alarm displays.

The sequence memory is acknowledged/reset in the following order:

- SILENCE = resets the audible alarm
- ACKNOWLEDGE = indicates recognition of an alarm
- RESET = returns the channel to the normal state

The alarm channels each generate two reflash signals A and B which can be linked to the auxiliary reflash output relays, for details please refer to section Configuration of reflash group alarms on page 29.

Each alarm channel is also provided with two interlocking signal inputs and one interlocking signal output. The interlocking signal inputs/outputs are:

- 0 = interlocking signal output. Can be connected to the other channels
- 1 = interlocking signal input. Blocks the reflash signal A
- 2 = interlocking signal input. Blocks the whole alarm channel, returns as acknowledged alarm
- 3 = interlocking signal input. Blocks the whole alarm channel, returns as a new alarm

The interlocking signal output is also always activated by an interlocking signal input being activated in the same channel.

Visual alarm indication

The state of the alarm channel is indicated by super-bright LEDs. A legend plate of transparent film is inserted in a slot at the edge of the also transparent plastic overlay. For more information, see section "Legend plate", page 21.

The first-out indication is accomplished with the four digit display on the front panel. The information stored in the event register can also be displayed on the digital display.

Acknowledge and reset is done with a push-button located on the plastic cover on the front of the unit or with two external push-button. The reset indicator LEDs on the front panel marked SILENCE, ACK, RESET/TEST shows which of the actions is to be performed. The reset sequence depends on the operational sequences.

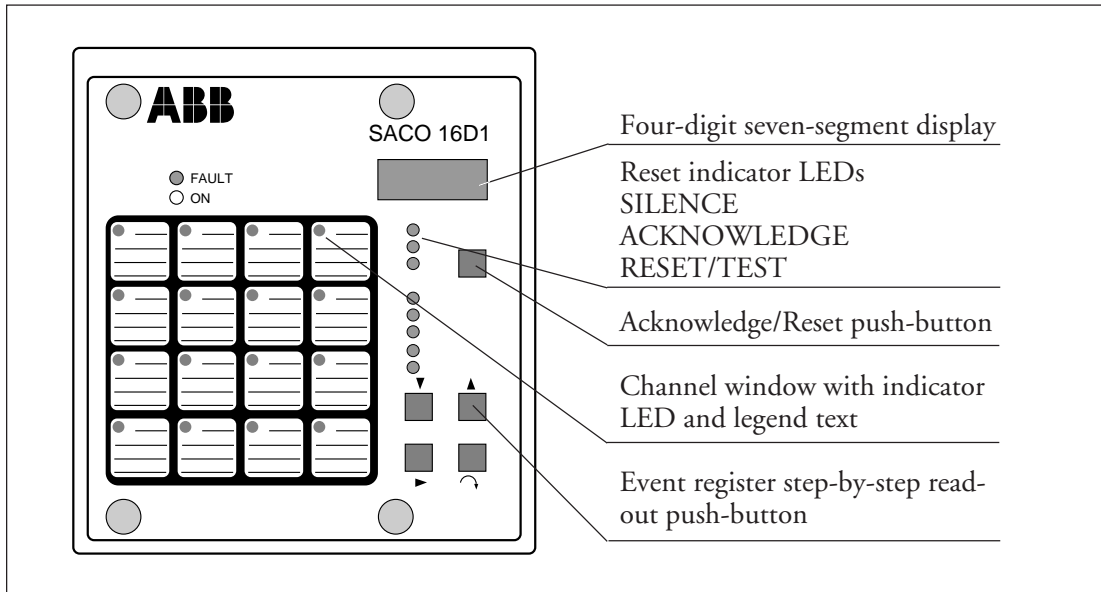

Fig. 5. Alarm indicators and push-buttons of the annunciator unit SACO 16D1.

Standardized operational sequences

The annunciator unit is supplied with five standardized field-selectable operational sequence alternatives of which the most adequate one for a certain application is selected. The operational sequences are:

- 0 = ISA A, automatic reset
- 1 = ISA A-1, automatic reset, separate reset of audible alarm
- 2 = ISA M-1, manual reset, separate reset of audible alarm
- 3 = ISA R-1, manual reset, separate reset of audible alarm, visual ringback on return
- 4 = DIN 19235, manual reset after return to normal if acknowledged while alert, visual ringback on return if acknowledged before return to normal

The above operational sequences are common to all the 16 channels. However the sequences can be altered on a per-channel basis according to the following:

- 0 = indications according to the selected sequence
- 1 = indications according to the selected sequence but including audible alarm also on return. Valid only for sequences ISA R-1 and DIN 19235
- 2 = field contact following indication without audible alarm

The acknowledge/reset operations required are determined by the annunciator unit itself and the acknowledge/reset operation being asked for is pointed out with the indicator LED. The annunciator unit is provided with two external control inputs, one for remote resetting of the audible device and an other for remote acknowledge/reset of the alarm channels.

NOTE!

The acknowledge/reset push-button on the front panel also operates as a visual display test button. The test is accomplished by pressing the acknowledge/ reset test button continually for approximately 1 second which causes all LED indicators to light up and the digital display to show 8888. The visual displays can not be tested if an alarm channel is unacknowledged or not reset. Pressing the test button for approximately 15 s activates the self-supervision auxiliary output relay and the FAULT LED.

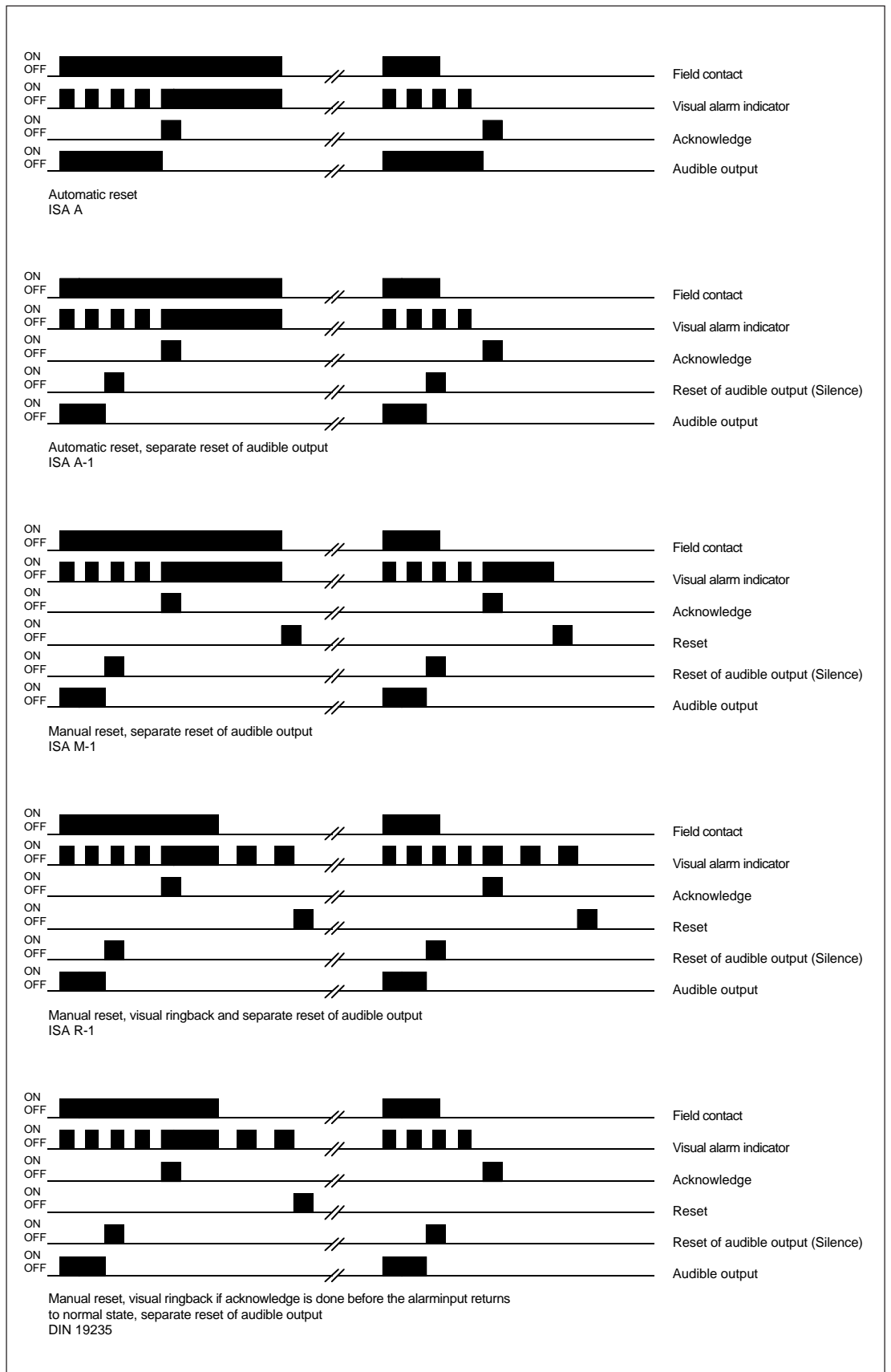

Fig. 6. Selectable alarm sequences.

First-out indication

The annunciator unit is provided with a first-out indication feature. The alarm channel which operates first is indicated in the digital display with a letter A and the channel number. The first-out indication always relates to the first

incoming alarm after an annunciator acknowledge/reset being performed. The first-out indication can be reset with the acknowledge/reset push-button.

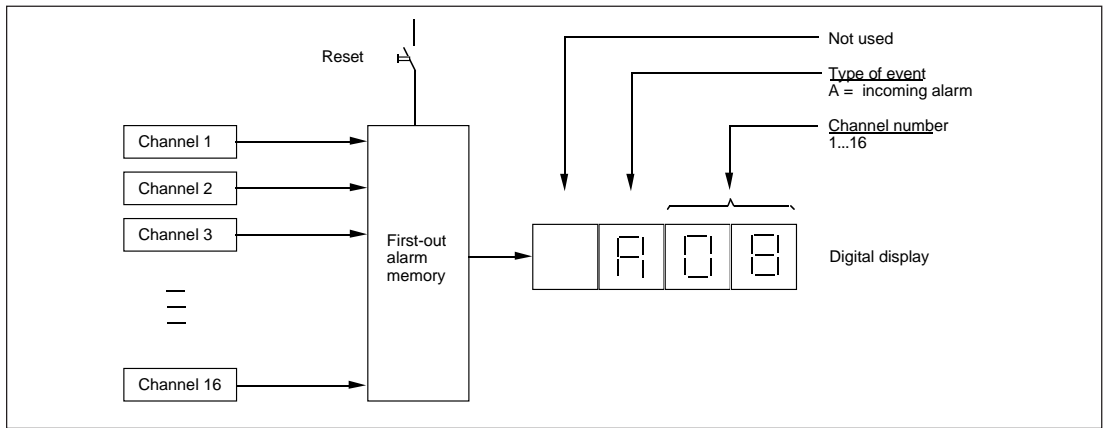

Fig. 7. Principle of the first-out alarm indication.

Event register

For evaluating of disturbances, the alarm annunciator unit has been provided with an event register, which enables the incoming and disappearing alarms to be read out. The register holds 9 events which can be read out on the digital display step by step using the push-button ↑.

The latest (youngest) information, i.e. address No 9, is read out first and then the events are represented in the display one by one until address No 1, which represents the oldest information, is reached.

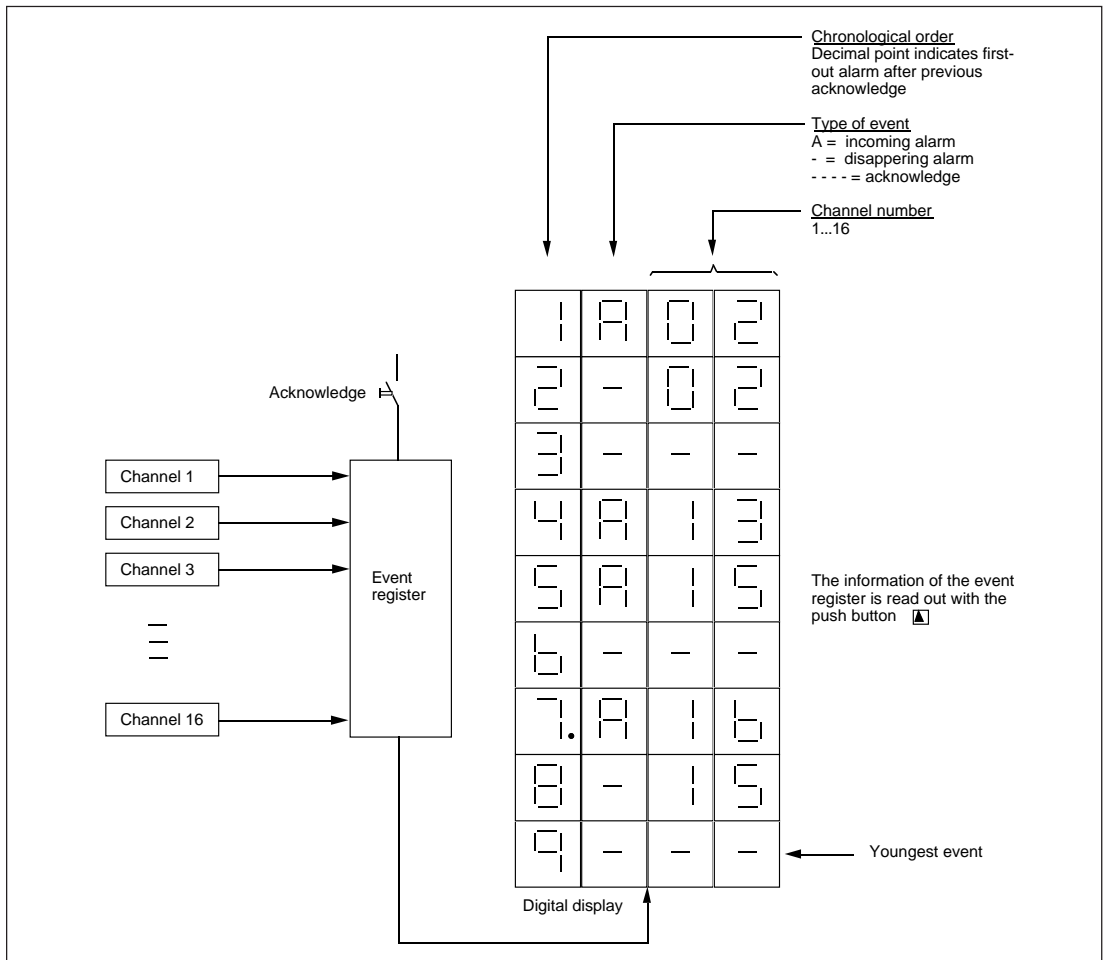

Fig. 8. Operating principle of the event register.

Event register for the serial communication

The annunciator unit incorporates a separate event register which contains information on the type of event and the channel number including a synchronous time stamp. This enables a higher level system to read out events from the annunciator over the SPA bus serial communication. The event register holds 50 events. The time stamps are relative and the time span is max. 60 s. The clocks of the interconnected units are synchronized, generally once per second, by the

higher level system (the SPA bus master). The time resolution between the channels is 5 ms.

The annunciator unit also includes a channel matrix register which operates in parallel with the event register and in which each channel corresponds to one bit. If a channel is activated during an overflow situation of the even register, the corresponding bit in the matrix register is activated.

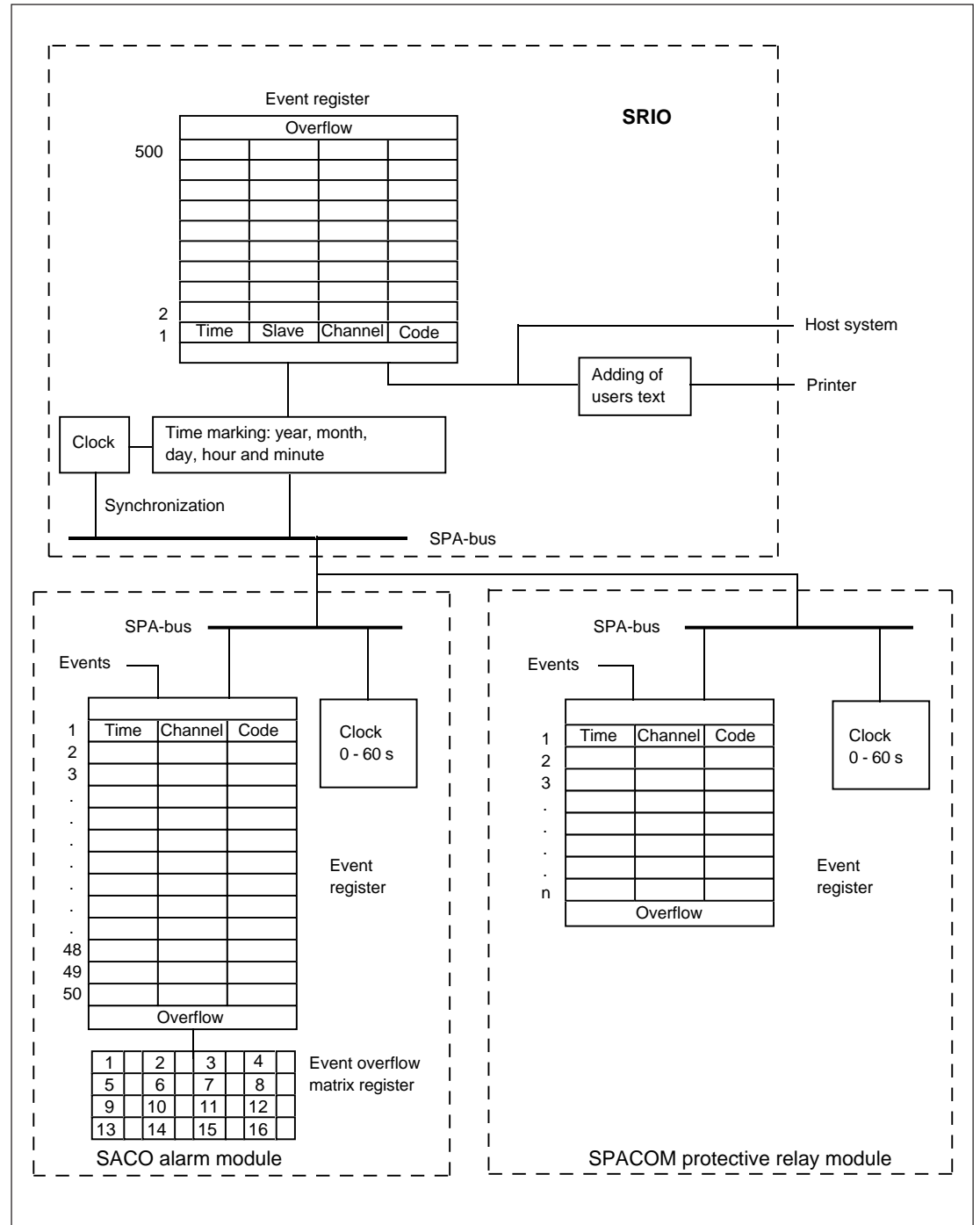

Fig. 9. Event registration in SPACOM systems.

Auxiliary outputs

The annunciator includes four auxiliary output relays. Two output relays act as group alarm refresh output elements, one auxiliary output

relay is dedicated for control of an audible device and one relay acts as an auxiliary output element for the internal self-supervision function.

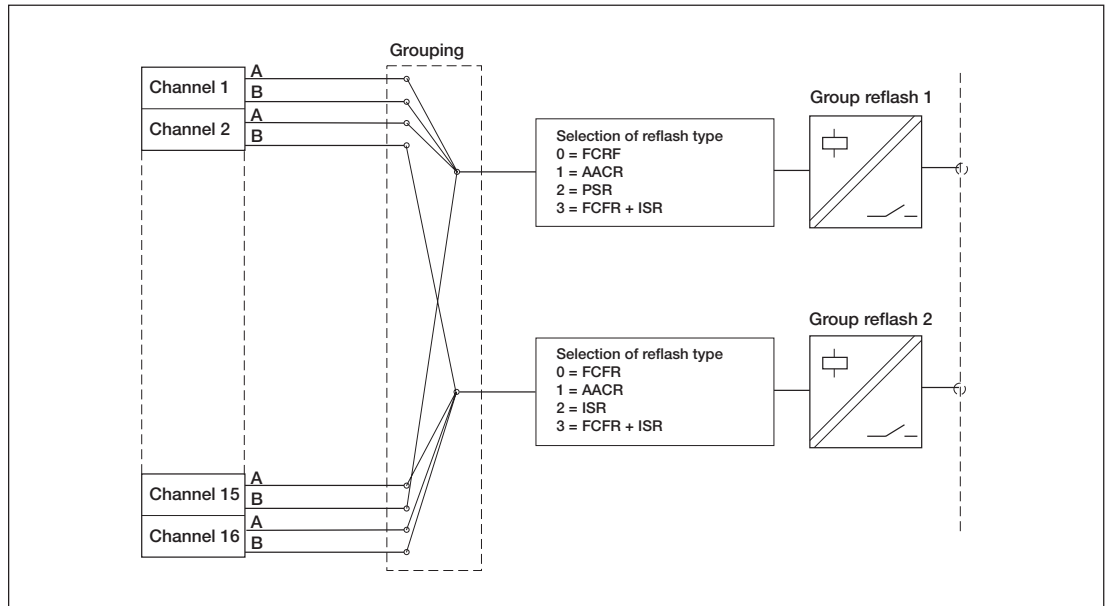

Fig. 10. Principle diagram of refreshes.

Group alarm refresh signals

Each alarm channel generates two refresh output signals, A and B, which can be freely linked to the two refresh output relays to form two group alarm refresh functions. The two group alarm refresh output relays can be given one of the following modes of operation selectable by programming, separately for both of the output relays:

- 0 = FCFR, Field Contact Following Refresh
- 1 = AACR, Acknowledge Action Controlled Refresh
- 2 = ISR, Impulse Shaping Refresh
- 3 = FCFR + ISR, Field Contact Following Refresh with a 300 ms interruption of the refresh signal any time a new alarm signal joins in an already active group alarm bunch
- 4 = FCFR + AACR, Field Contact Following Refresh and Action Controlled Refresh (see figure below)

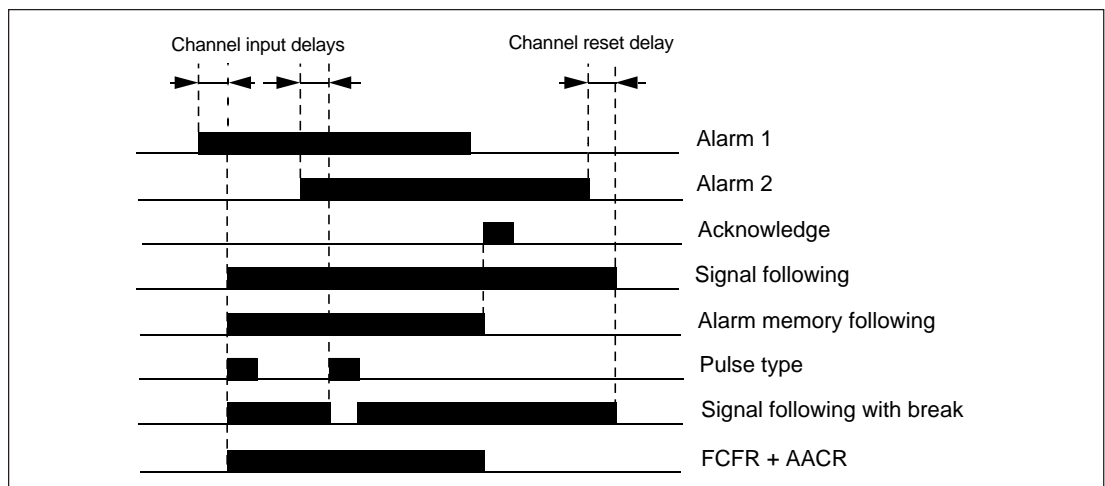

Fig. 11. Principle diagram for the different refresh signal types. The alarm signals 1 and 2 are grouped to the same group alarm refresh signal.

NOTE! The refresh signals are always accompanied by a certain basic delay. The basic delay time depends on the number of incoming alarm signals per time unit and on the number of

internal interlocking levels in use. The basic time delay of the refresh signal is 70 ms if only one alarm signal is received within a time period of 200 ms and if no interlockings are used.

Audible device output

Generally the relay output for control of an audible device operates if one of the 16 alarm channels is activated. Every channel can also be separately programmed to deliver an audible ringback when the alarm channel returns to normal state. If an alarm channel has been programmed for a sequence providing a field contact following visual indication only, no audible alarm will be generated, please refer to "Standardized operational sequences" on page 8.

The audible device can be silenced by means of the acknowledge/reset push-button or by means of an external control signal applied to the remote silence control input (17) of the annunciator unit.

An incoming alarm signal, for which only the audible alarm has been silenced but the alarm signal has not been acknowledged nor reset, will not produce a new audible alarm if the field contact starts "pumping".

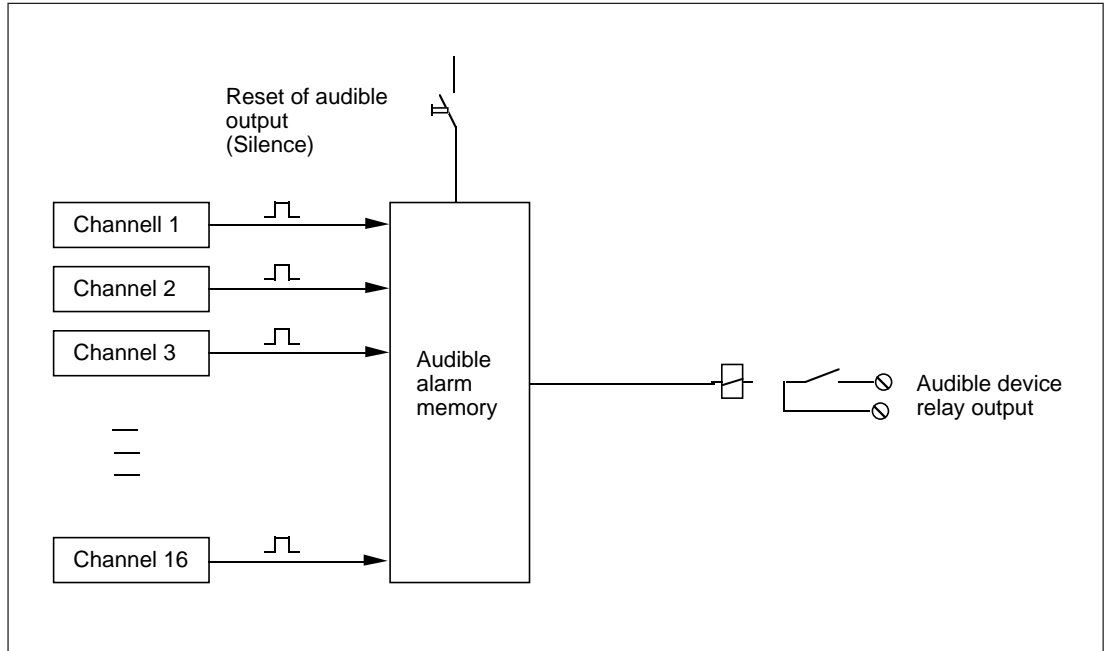

Fig. 12. Principle diagram for the audible alarm.

Self-supervision output

The annunciator unit is provided with extensive self-supervision functionality which, in case of an internal fault or if an internal malfunction is detected, causes an operation of the self-supervision auxiliary output relay. The self-supervision system monitors continuously the internal voltages, the program execution and micro-processor logic. An internal malfunction of the unit produces an automatic restart attempt and if the reason for the malfunction has disappeared, the normal operation of the annunciator unit continues.

If the fault on the program, the microprocessor or the supply voltages is of a permanent nature, the LED indicator marked FAULT is switched on and the self-supervision auxiliary output relay drops off (normally energized). At the same time all the other auxiliary outputs are locked including the serial communication port. If the voltage of the logic circuits totally disappears, the LED indicators marked ON and FAULT are turned off, but in other respects the functions are as described above.

If a fault occurs in the 48 V DC field contact voltage, generated by the annunciator unit, the FAULT LED is switched on and the self-supervision auxiliary output relay drops off (normally energized). The fault information can be sent

over the serial communication. If the control voltage of the auxiliary output relays disappears, the self-supervision auxiliary output relay drops off.

The following fault messages can be shown in the display:

- - - 1 = parameter memory circuit not available
- - - 2 = faulty parameter memory (checksum error)
- - - 3 = event register blocked due to field contact "pumping" (se below)
- - - 4 = undervoltage in field contact circuit supply

The serial communication is also supervised. The decimal point in the corner to the right in the display starts blinking if there hasn't been any serial communication within the last thirty seconds. The blinking decimal point indicates a fault on the communication bus or in the higher level system.

If no serial bus is connected to the annunciator, the bus supervision can be taken out of use. This is done by giving the parameter V201, "setting of data transmission rate", the value 1(synch out), se the section "Selections of the serial interface", page 32.

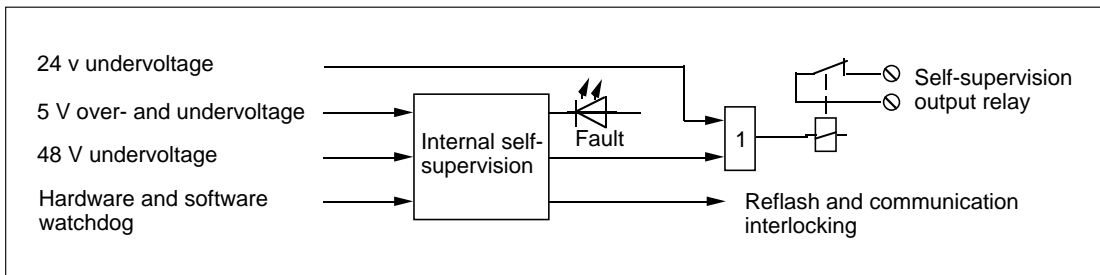
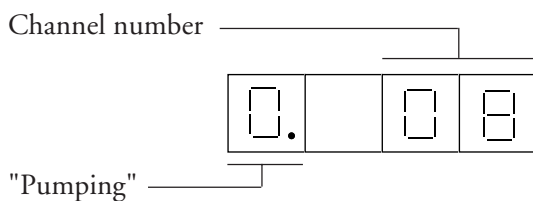

Fig. 13. Principle diagram for the self-supervision system.

To prevent a "pumping" field contact from blocking the communication to a higher level system, the unit is provided with a setting to indicate how many incoming alarms are allowed from one channel within one minute. In case the setting limit is exceeded the channel is blocked until the alarms per minute again goes below the set value. A channel with a "pumping" field contact is indicated as follows:



The indication is reset with the RESET push-button.

The "pumping" supervision is programmed by parameter S11 (channel related settings):

- 00 = "Pumping" supervision not in use
- 01...99 = Maximum alarms per minute

It has been mentioned in the section describing the functions of an alarm channel that each channel is provided with three interlocking input types, 1, 2 and 3, and one interlocking output type, 0.

The interlocking input type 1 prohibits, when energized, only the channel reflash signal type A from being transmitted, while the interlocking input type 2 blocks the whole alarm channel and if the blocking drops of while the channel is still active, the channel will be indicated as an acknowledged alarm. The interlocking input type 3 also blocks the whole channel but returns as a new alarm when the interlocking drops of. The interlocking output type 0 is activated by an alarm channel being activated or by one of the interlocking inputs being activated. The feature mentioned last enables the annunciator unit to be programmed with up to eight interlocking levels.

Note!

If more than three interlocking levels are used it will effect the resolution on the time stamp for the event register.

The interlockings are distributed between the different channels via eight internal interlocking lines, see figure on page 16.

Each channel can be connected to two interlocking lines. This means that alternatively both the interlocking inputs of an alarm channel are connected to two different interlocking lines, or the interlocking output and one of the interlocking inputs are connected to two different interlocking lines.

When an external interlocking signal is to be brought into the annunciator unit, one of the alarm channels can be used as an interlocking input. In this case the alarm channel may be given the field contact following visual indication sequence (S4 = 2) so no audible alarm will be generated from the channel, see page 29.

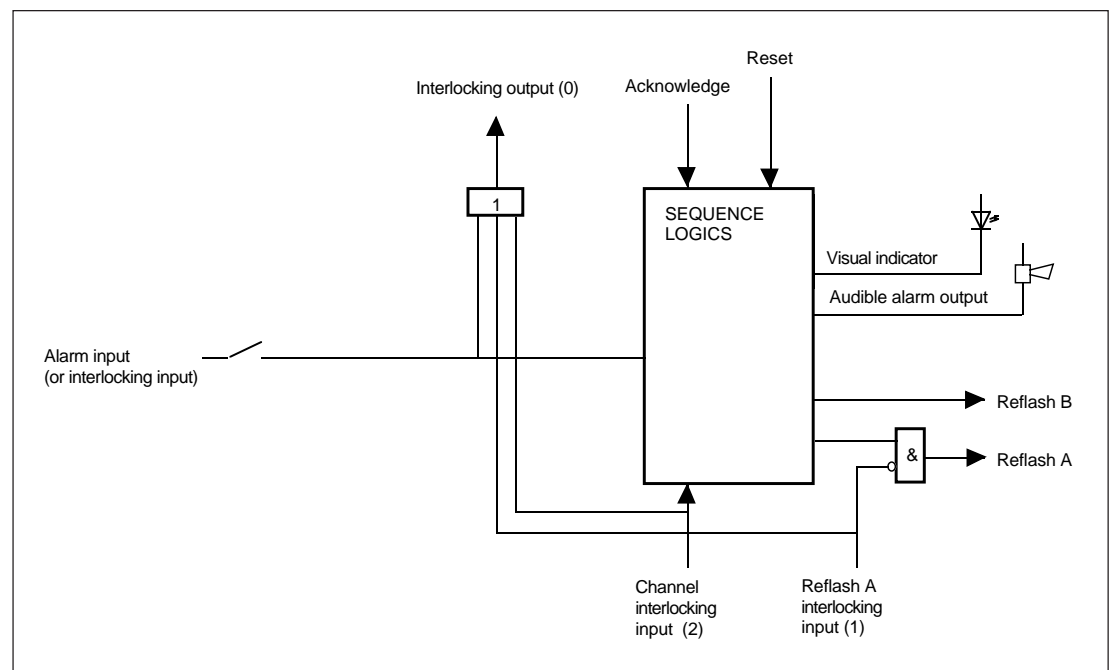

Fig. 14. Principles for the interlocking functions of an alarm channel.

Example of channel interlocking configuration

An external interlocking signal is connected to input channel 10 which is configured to give an interlocking output to interlocking line 1. When active, line 1 interlocks reflash signal type A on channel 7 and locks channel 8 totally. Channel 8 gives also an interlocking output to line 2 which in turn interlocks reflash signal type A on channel 5.

The connections described above have been marked with dots on the corresponding lines in figure 15. The programming technique using the push-buttons on the front panel is described on page 30.

To give a good overview of the interlocking configuration the figure 15 can be used when configuring the interlocking scheme.

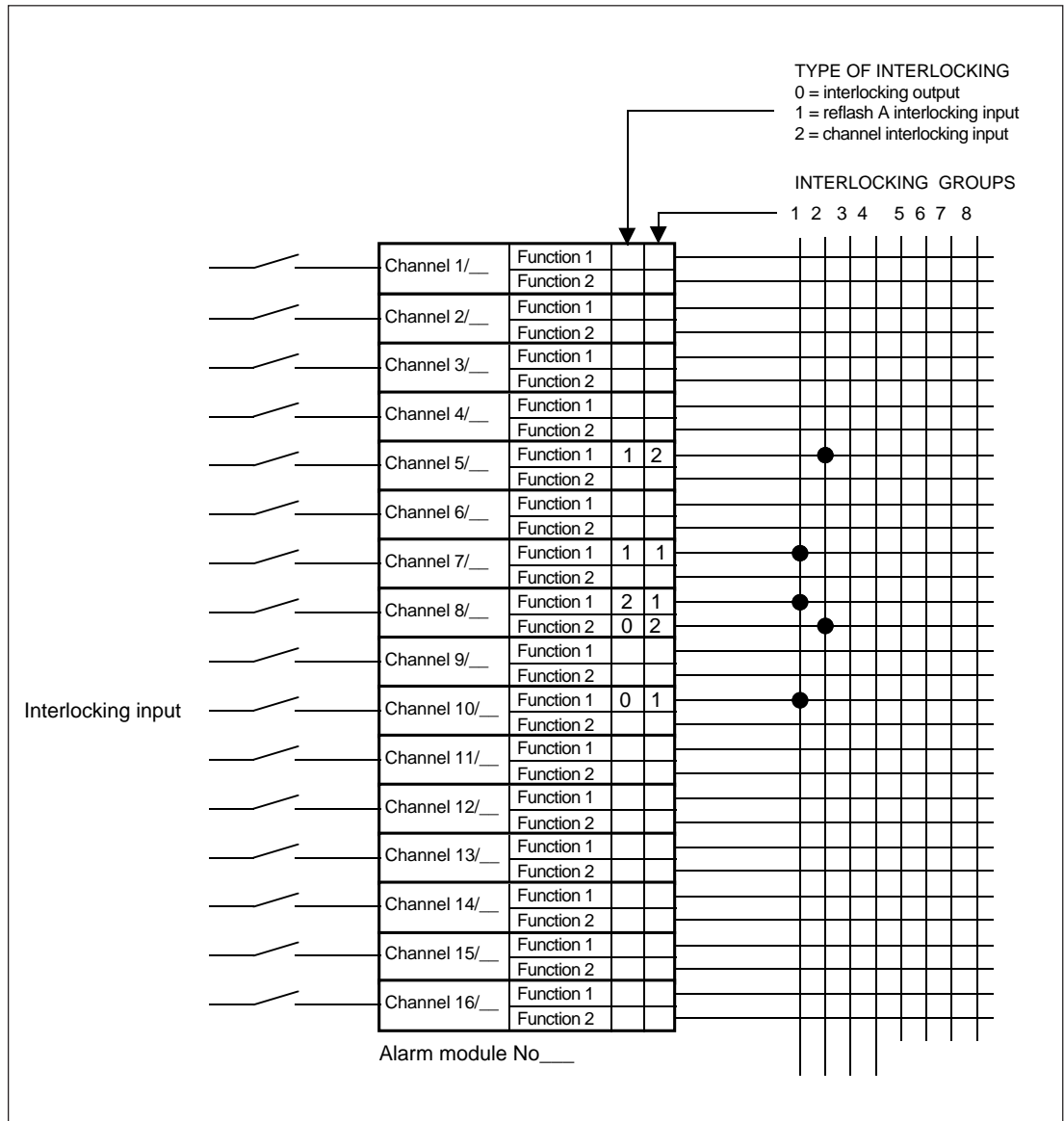

Fig. 15. Interlocking diagram.

Serial communication interface

The alarm annunciator unit comprises a serial communication port over which the unit can be connected to a local reporting and data communication system using the SPA bus protocol. The physical connection for the serial interface is located on the screw terminals on the back of the unit using terminals 1, 2, 3, 13 and 14 (see figure 16) The serial interface is according to the RS 485 standard.

Using electrical connection the transfer distance is about 20 to 30 m depending on the interference level of the installation. The maximum allowed ground potential difference between the units is $\pm 10V$.

A fiber optical connection module, SPA-ZC 17 or SPA-ZC 21 is used to connect the unit to a fiber optical bus. The transfer distance using fiber optical media is approximately 30 m for plastic fiber and 2 km for glass fiber.

Note! Because of the disturbant environment (like in substations) where the units are operating it is always recommended to use fiber optical communication.

By using the LON/SPA gateway, SPA-ZC 100, the alarm annunciator might also be connected to the LON bus.

The SPA bus protocol is described in the document SPA bus communication protocol V2.5, 34 SPACOM 2 EN1 and the LON Talk protocol is described in the document LON bus - LON Works network in protection and control systems; 1MRS750035-MTD EN

The speed of the serial communication is normally 9600 bits/s

Through the serial communication the following information is read from the unit:

- the event registers including the time markings
- the state of the channels and of the system
- the programmed parameter values
- pulse counter values

The following data can be written to the unit:

- time synchronization
- audible device reset
- alarm channels acknowledge and reset
- control of an alarm channel
- control of output relays
- control of the interlocking channels
- setting values
- testing of the unit

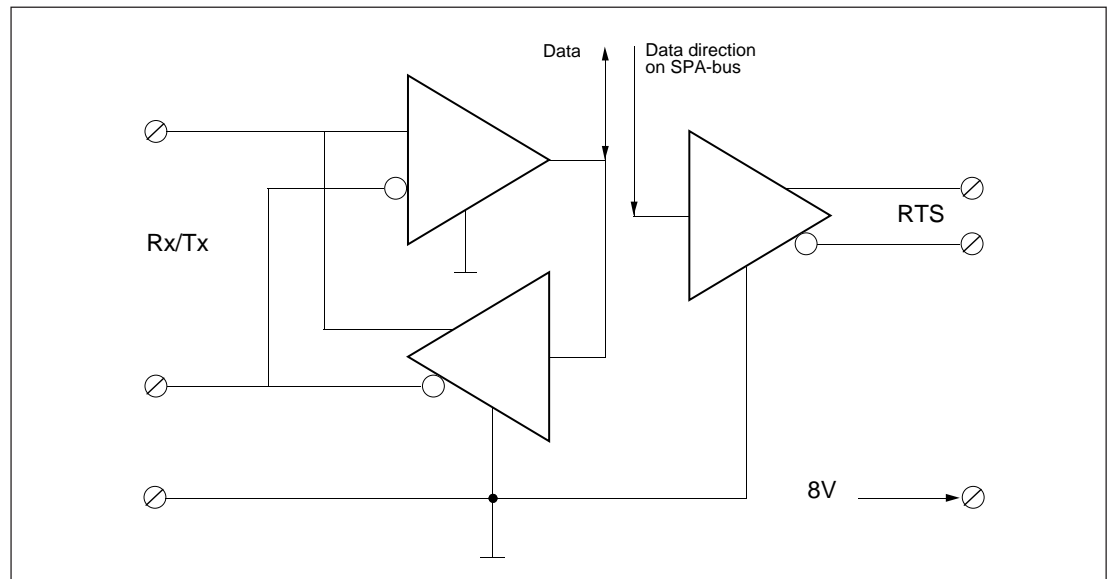

Fig. 16. Principle lay-out of the serial communication interface.

Synchronizing of the blinking sequence

If several units are located close to each other without any connection to a higher level system, it might be desired to synchronize the blinking sequences between the units. This is done by connecting the serial interfaces together and to configure one of the units to transmit a synchronizing signal (V201=1) and the others to receive that signal (V201 = 0).

V201 Setting of transmission rate

- 0 = 9600 bits/s, synch pulse receiver
- 1 = 9600 bits/s, synch pulse transmitter
- 2 = 9600 bits/s
- 3 = 4800 bits/s
- 4 = 2400 bits/s
- 5 = 1200 bits/s
- 6 = 300 bits/s

Programming

The parameter values are stored in the unit in a non-volatile EEPROM memory. Thus the setting of parameter values can be performed and changed by means of the push-buttons on the front panel or via the serial communication using e.g. the SMS 010 software. This means that the annunciator unit is fully field-programmable.

For connecting a PC directly to the serial interface of the unit (for parameterization) the cables SPA-ZP 6A3 and SPA-ZP 21A are used.

The entry to the parameter memory can be blocked by means of a plug selector which is located on the PCB right behind the front panel, see figure 31 on page 27.

Auxiliary power supply system

The plug-in power supply module of the annunciator unit is specified for supply voltage within the range of 80...265 V AC or DC (SPGU 240A1) or 18...80 V DC (SPGU 48B2).

The annunciator unit is equipped with one power supply module but with two identical supply voltage inputs (figure 17). Generally only one of the inputs is used, but the annunciator can be supplied from two sources. It must, however, be noticed that the two supply inputs

are galvanically connected. Thus, in case two supplies are used, it is recommended that the two supply sources are galvanically isolated. If an ac supply is used, an isolating transformer can be installed to provide the galvanic separation (figure 18).

The insulation level between the supply source and the electronics as well as between the field contact circuits and the electronics is 2 kV, 50 Hz, 1 min.

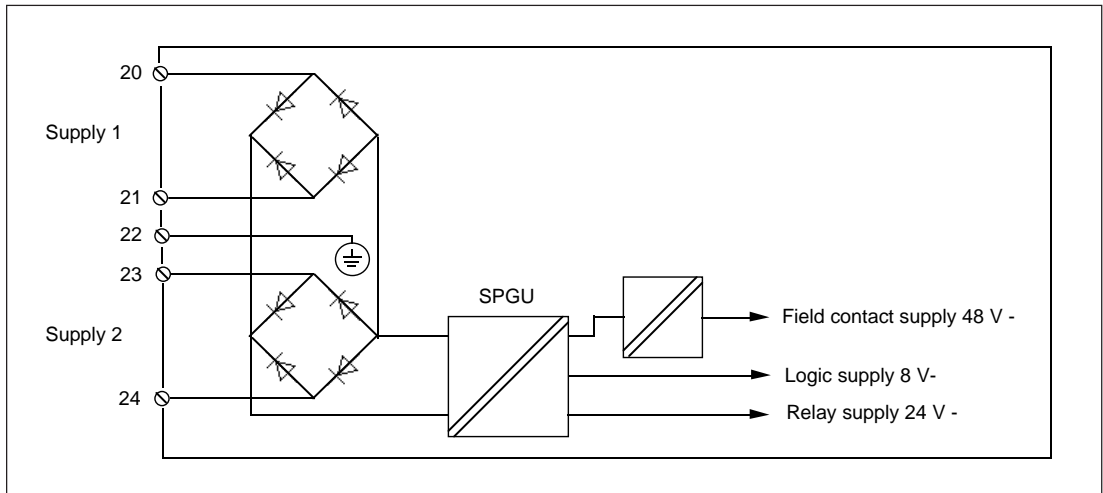

Fig. 17. Principle diagram for the power supply system.

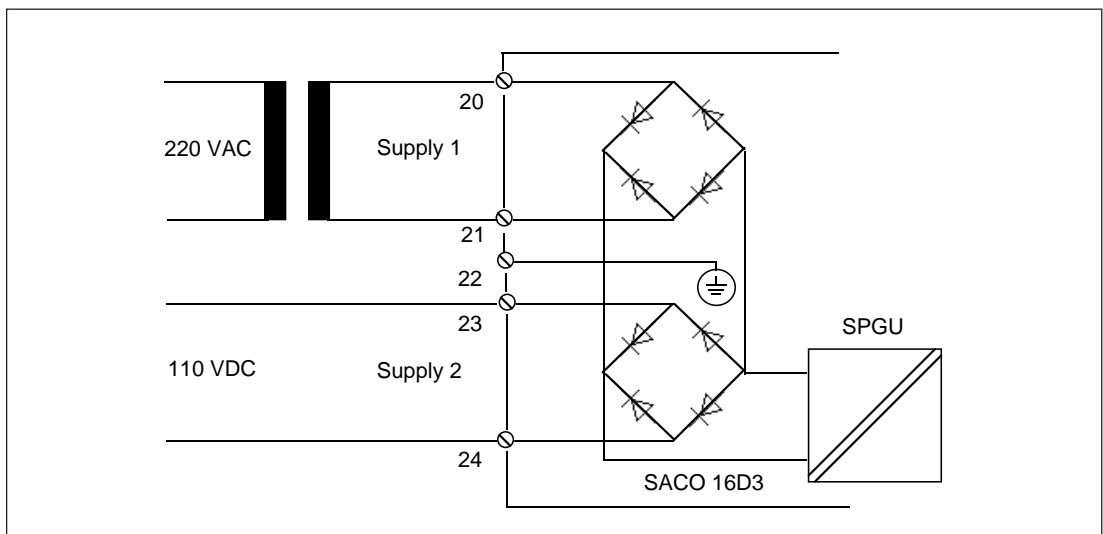

Fig. 18. Example of double power supply arrangement. Supply 1: 220 V AC with an isolating transformer 20 VA, 220 V/220 V. Supply 2: 110 V DC supply.

Application

Mounting

The annunciator unit is intended for flush mounting and provided with two mounting brackets. The depth behind the panel can be reduced by means of raising frames. Three raising frames are available, 40 mm, 80 mm and 120 mm:

- SPA-ZX 101, 40 mm raising frame
- SPA-ZX 102, 80 mm raising frame
- SPA-ZX 103, 120 mm raising frame

The corresponding mounting brackets are delivered along with the raising frames .

The mounting frame is furnished with a rubber gasket which provides a degree of protection by enclosure to IP 54 between the case of the annunciator and the mounting panel.

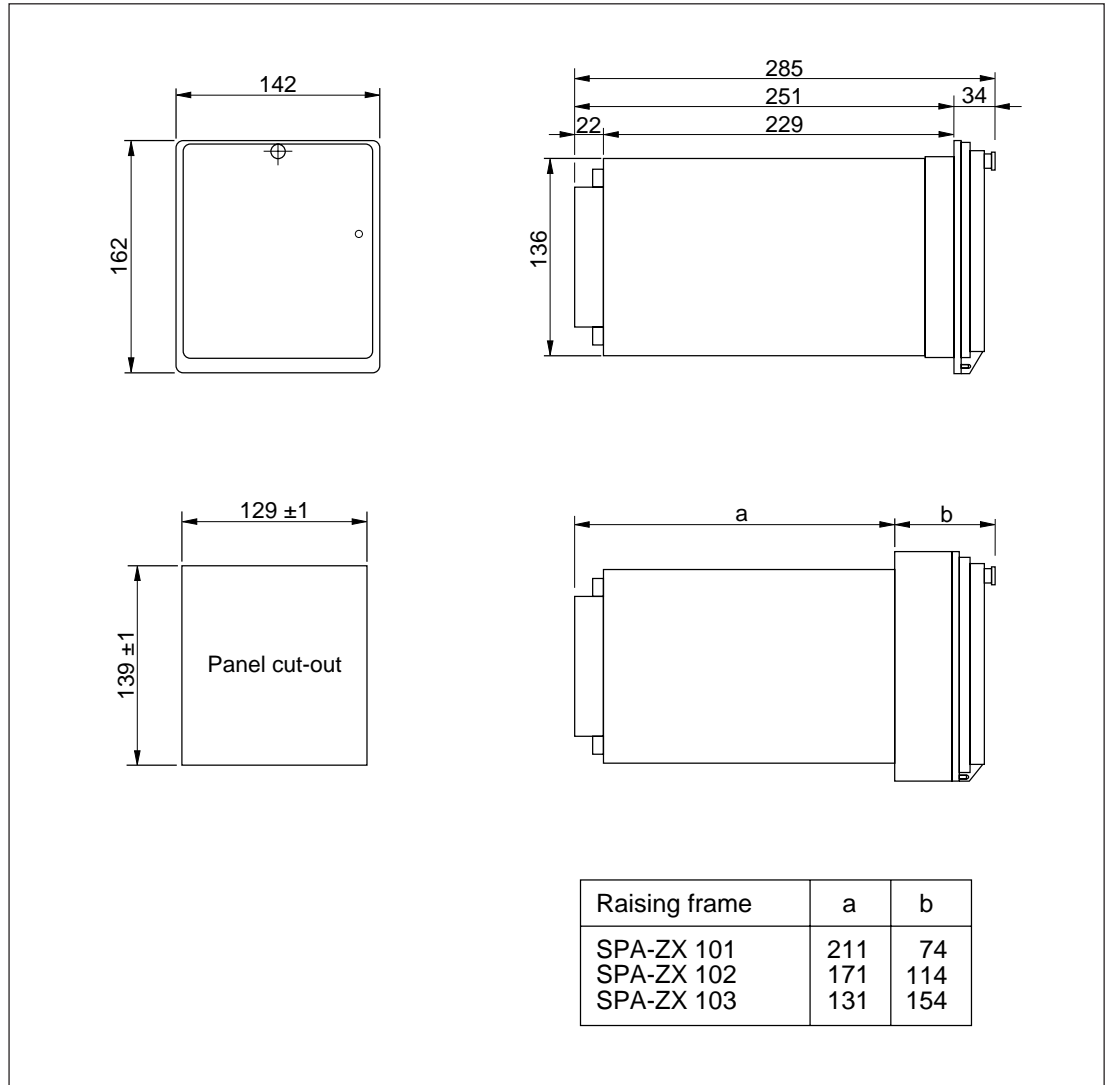

Fig. 19. Dimension and mounting drawings for the annunciator unit SACO 16D1.

The screw terminal to facilitate all input and output connections are located on the rear panel of the annunciator case. Each screw terminal can accommodate one or two max. 2.5 mm² wires. No terminal lugs are needed.

A connection diagram is attached to on one of the side surfaces of the annunciator case.

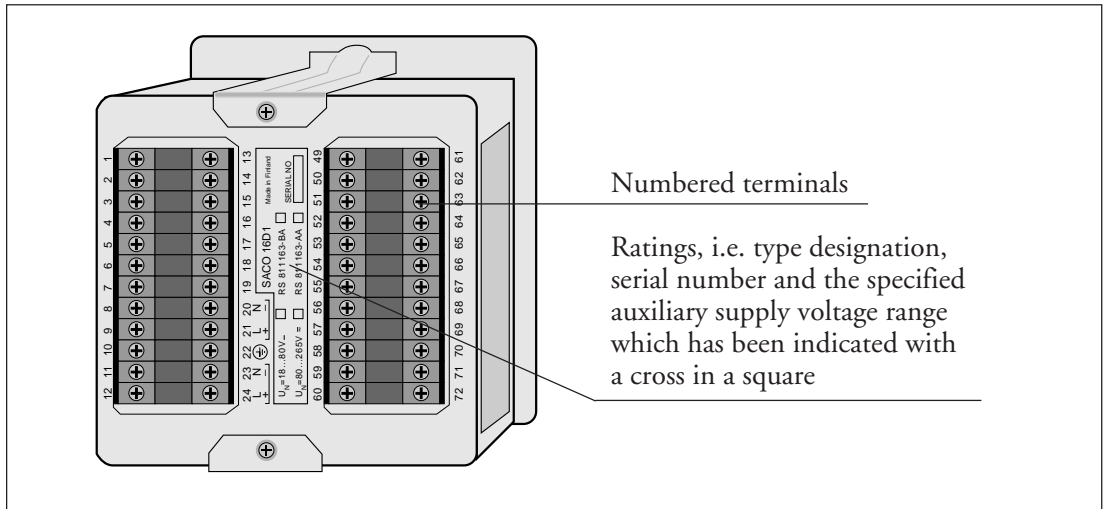

Fig. 20. Rear view of the annunciator unit SACO 16D1.

Connections:

Auxiliary supply	20-24
Protective ground	22
Field contact circuits	49 - 72
Acknowledge/reset	16 - 18
Reflash outputs	5 - 12
Serial interface	1 -3 and 13 - 14

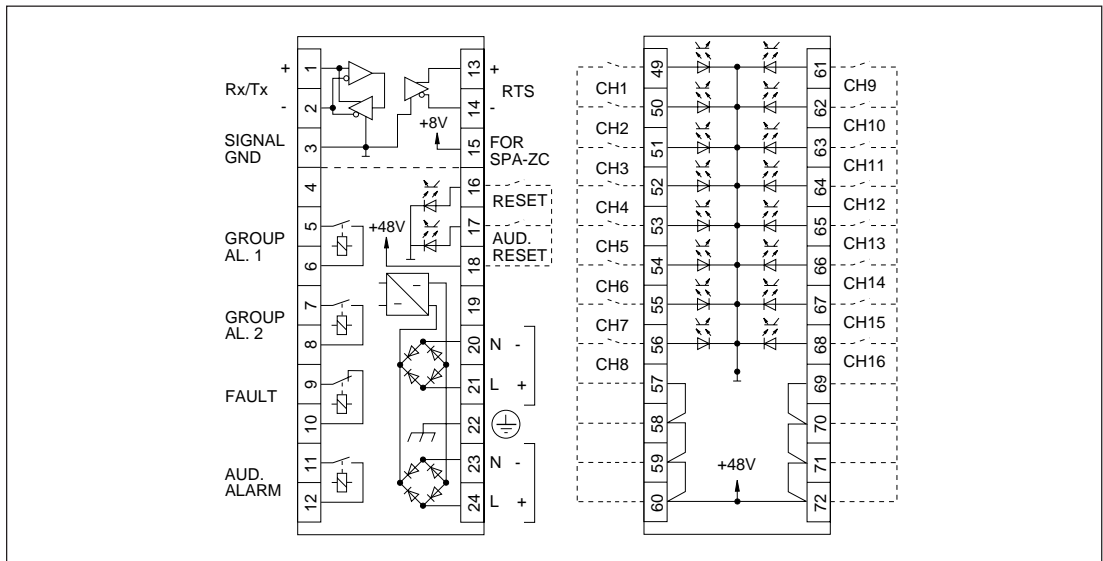

Fig. 21. Connection diagram for the annunciator unit SACO 16D1.

Important 1

Make sure that the connected auxiliary supply voltage complies with the specification. If two auxiliary supply voltages are used, both voltages are to be in accordance with the specified supply voltage range.

Also make sure that the Protective ground (22) is properly wired.

Important 2

If the annunciator is powered from two separate auxiliary voltage sources, the supply networks must be galvanically separated e.g. with an isolating transformer if the customer does not accept that the supply networks are galvanically interconnected.

Start-up When the auxiliary supply voltage is connected, all active alarm channels are indicated as already being acknowledged. These alarms are not to be found in the event register.

Operational test The unit is tested by first acknowledged/reset all alarms and then the acknowledge/reset push-button is kept depressed for about 1 second. This move will cause all LED indicators, except the FAULT LED, to be switched on and the digital display to indicate 8888 as long as the push-button is depressed. If the acknowledge/reset push-button is depressed for more than 15 s, the self supervision output relay drops of and the FAULT LED is lit.

The operational test comprises the internal system circuitry. The field contact circuits and auxiliary devices must be tested separately.

Legend plate The screened plastic overlay is provided with translucent windows for the 16 channels. The channel legend texts are applied on a drawing film also square-ruled to form 16 text fields. The drawing film can be inserted in a slot along the left-hand edge of the front plate, see figure 22. The front plate including the legend text film and the screened plastic overlay are kept in place by means of four finger screws.

annunciator unit a sheet of drawing film comprising three legend plates is delivered.

The channel text surface comprises 20 mm x 20 mm and the text area is ruled with four lines.

NOTE!
The starting point for the first line of the channel legend text is intended a few millimeters from left in order not to cover the visual LED indicator of the channel.

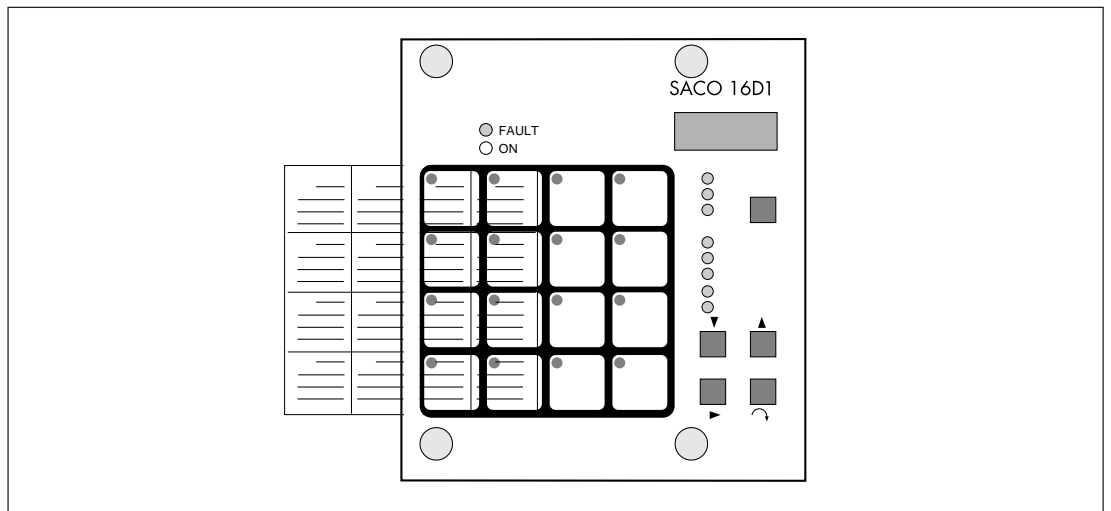

Fig. 22. Partially withdrawn a drawing film.

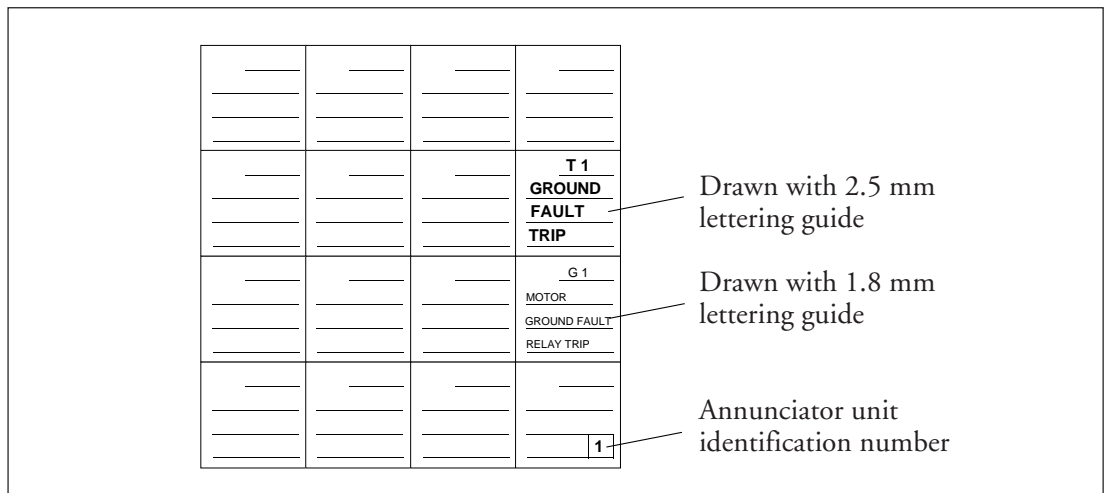

Fig. 23. Channel legend text drawing film.

Selection of output contact mode

Upon delivery the output contacts of the annunciator unit are selected for a NO mode of operation except for the internal self supervision output relay that is normally energized and its output contact is open, i.e. NC. If needed the mode of operation of the output contacts can be changed to the NC.

The output relays are physically located on the PCB of the Input/Output module SWIM 2A1. Access to the module is obtained so that first the lid is opened and the front panel dismantled and then the microprocessor module SWPM 3A1 is withdrawn.

WARNING!

Although the auxiliary supply voltage of the annunciator unit has been switched off, external voltages may be present in the auxiliary reflash contact circuits.

When the Input/Output module has been withdrawn from the case, the PCBs can be separated from each other so that the retaining tongues of the plastic spacing plugs are depressed and the upper PCB is lifted. The jumper wires on the PCB corresponds to the output relays as follows:

- W1 reflash output relay 1
- W2 reflash output relay 2
- W3 self-supervision system output relay
- W4 audible device output relay

The mode of operation selection for the output relays is carried out by moving the concerned jumpers on the PCB in the way illustrated by the legend print on the PCB.

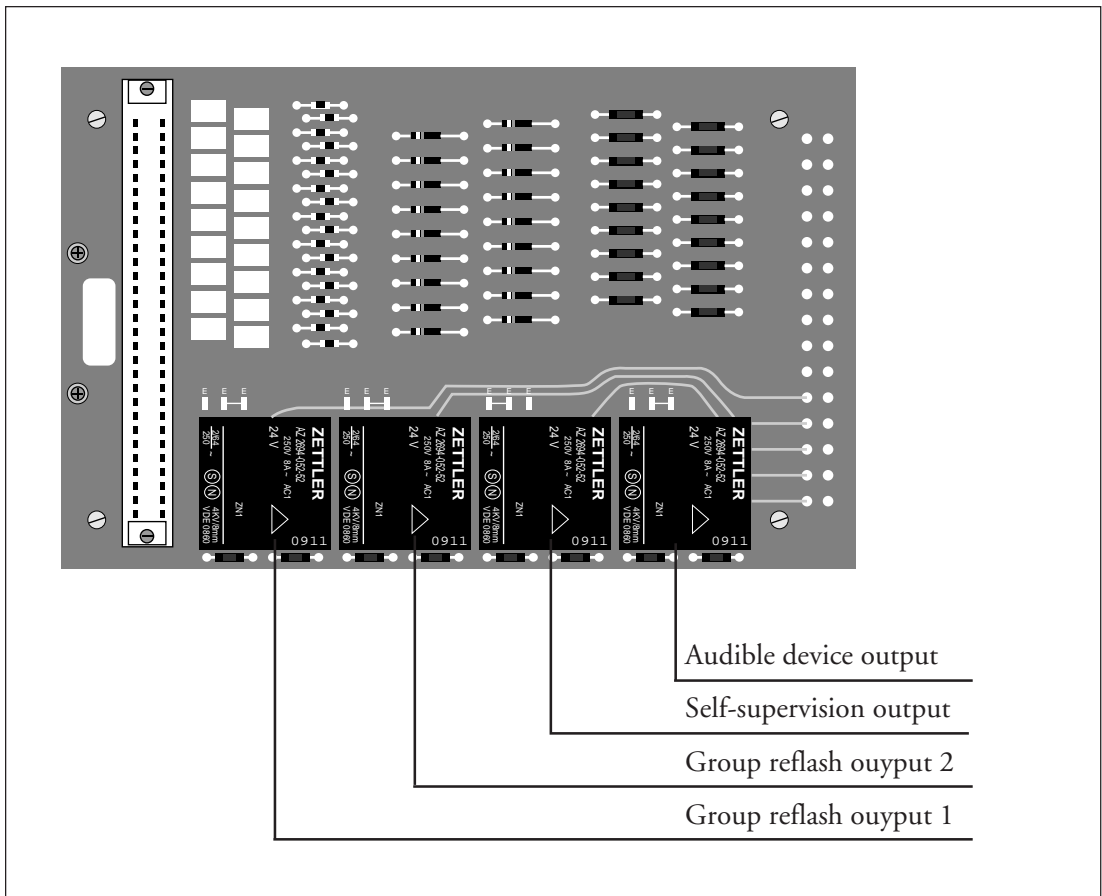

Fig. 25. Output relays of the I/O module SWIM 2A1.

The alarm annunciator unit is very easy to use. In principle the use of the annunciator is controlled from the "Reset and test push-button" only. However, when parameters are selected

and altered and when stored information is read out from the event register, the four push-buttons in the lower right hand corner are used.

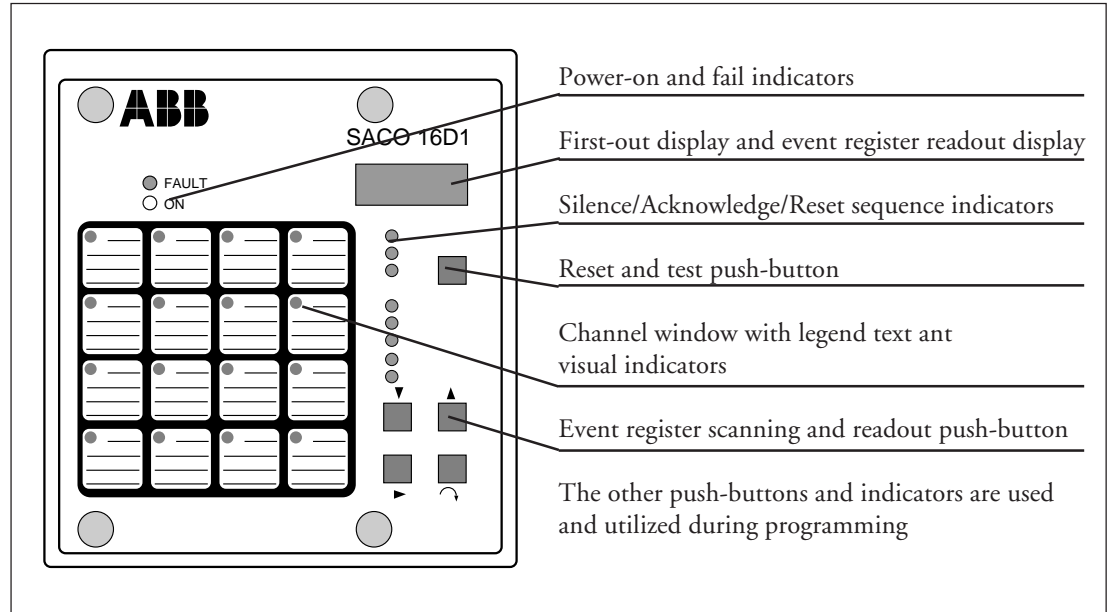

Fig. 26. Front panel indicators and event register push-buttons for the annunciator unit SACO 16D1.

During a normal process condition, when no alarms are active and when all acknowledges/resets have been performed, the only indicator glowing on the front panel is the ON LED. When alarm signals are received, the alarm channels starts and the visual LED alarm indicators are activated according to the selected sequence programs. At the same time the first alarm channel number and a letter A in front of it is to be seen in the display. The SILENCE/ACKNOWLEDGE/RESET LEDs indicate the next reset function at hand.

- The reset functions are:
- SILENCE = stops the sound of the audible device
 - ACKNOWLEDGE = indicates recognition of an alarm
 - RESET = returns the alarm channel to normal state

The SILENCE and ACKNOWLEDGE sequence actions can also be carried out with external push-buttons. The external push-buttons are wired to the terminals AUD. RESET (17) and RESET (16) of the annunciator unit.

First-out alarm indication

The first-out alarm indication is a feature of the annunciator unit which means that the first alarm channel to start after a reset is indicated

with a letter A and the channel number in the four-digit display.

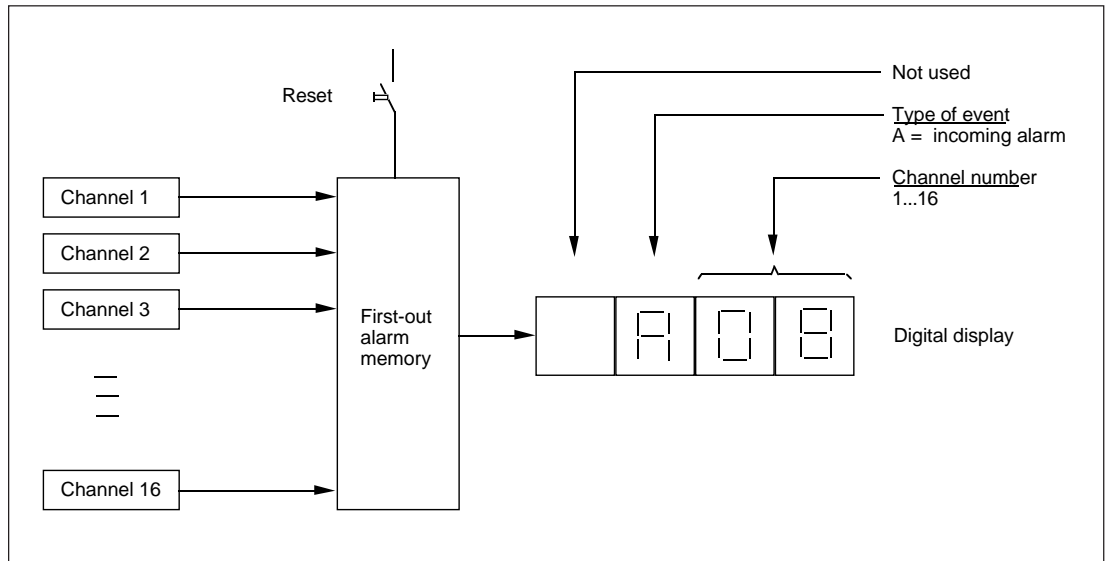

Fig. 27. Principle of the first-out alarm indication.

The first-out alarm indication is removed from the display with the acknowledge/ reset push-button.

Event sequence register

The annunciator unit continually registers the incoming events and the latest 9 events are always stored in their chronological order in the event sequence register from which they can be read out from the digital display at any time.

The events are read out with the push-button \uparrow , which becomes accessible when the plastic lid has been opened. Each time the \uparrow push-button is depressed, a new event is shown in the display starting with the youngest event and ending up with the oldest event after which the display is turned off. The stepping through of the event sequence register can be repeated if required.

The stepping through always proceeds in the same direction.

IMPORTANT!

When the annunciator unit is turned into the programming mode by the push-button \uparrow , the information in the event sequence register is automatically erased. The information in the event sequence register is also lost if the auxiliary supply of the annunciator unit is interrupted. However, the event register for the serial communication will not be reset when the unit is turned into programming mode only if the auxiliary supply is interrupted.

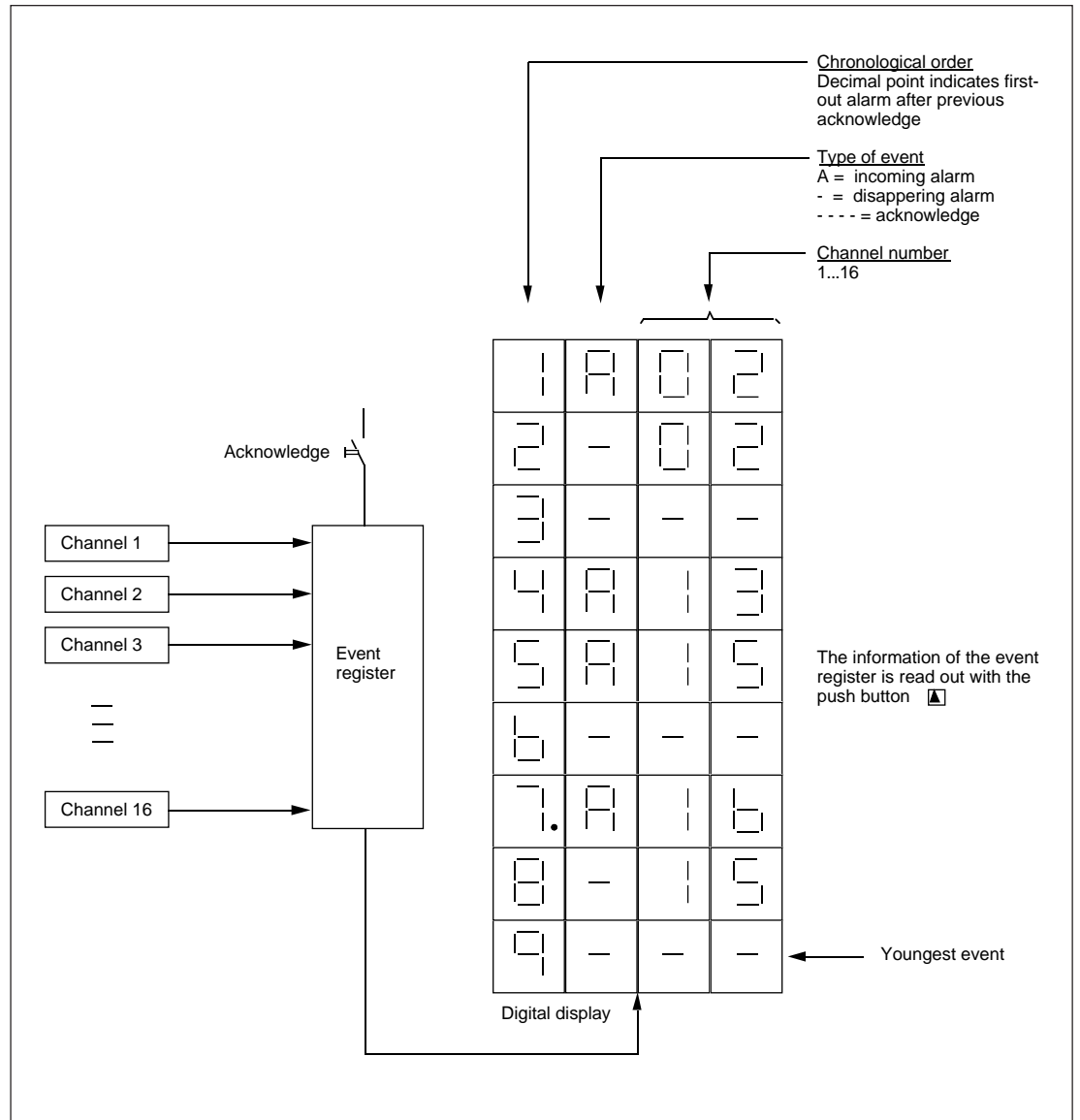

Fig. 28. Principle of the event sequence register.

Programming

The alarm annunciator unit is a very flexible device but at the same time easy to use.

The programming work is carried out easily by means of the programming push-buttons on the front panel or via the serial communication using e.g. the SMS 010 setting and monitoring software. The parameter values are stored in a non-volatile EEPROM memory which means that the parameter programming is a very straightforward action and that the information content of the memory is maintained even in a loss of supply situation.

The parameter values can be and are usually finally defined after that the annunciator unit has been mounted at site during the commissioning work.

By means of a plug selector located on the PCB just behind the front panel the switching over of the annunciator unit into the programming mode can be prohibited. In this way the program memory of the annunciator unit can be protected against unauthorized access.

Programming technique

The annunciator unit is programmed by means of the five push-buttons and the four digit display

on the front panel. The push-buttons are accessible after that the plastic lid has been opened.

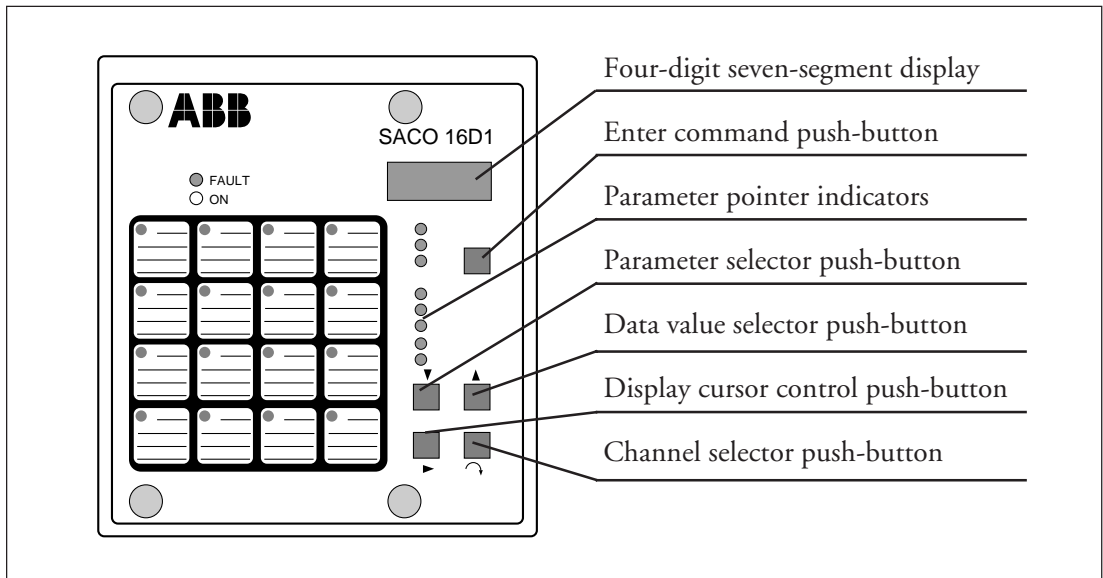

Fig. 29. Front view of the annunciator unit.

For better HMI (Homan Machine Interface) the unit can be programmed via the serial interface using a PC program, e.g. SMS 010 software.

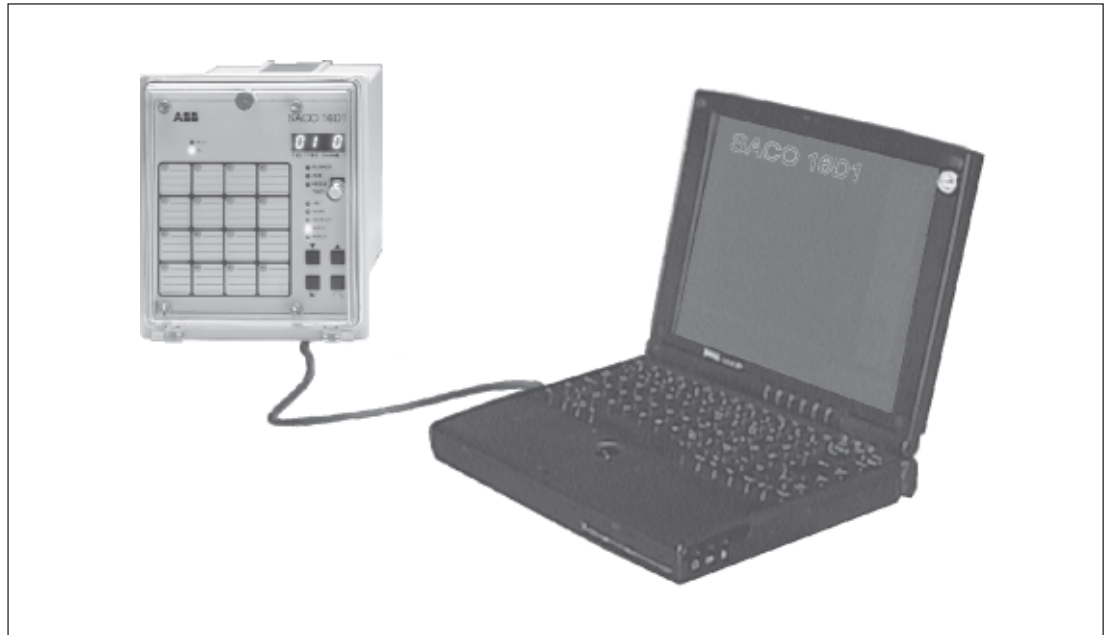

Fig. 30. SACO connected to a SMS PC.

IMPORTANT!

When the programming work is done the unit goes off-line, which means that the annunciator unit is set out of its normal operation during the time it is being programmed. The procedure when it goes back from programming mode is the same as when it starts up.

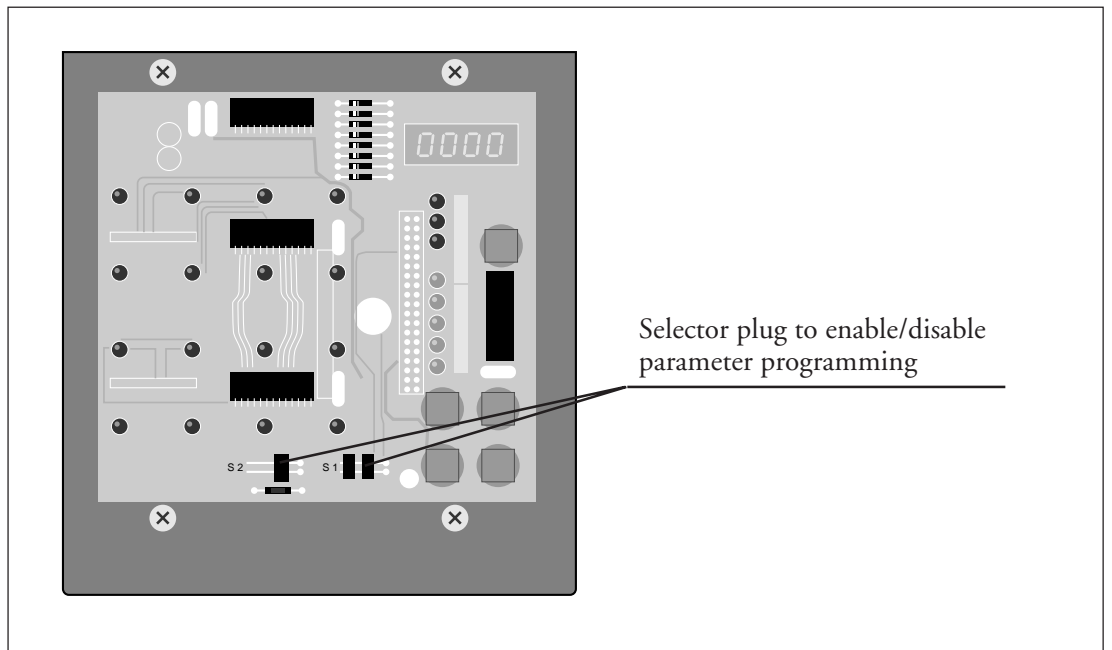

Fig. 31. Selector plugs.

IMPORTANT!

The plug selector which is used to enable or prohibit programming of the annunciator unit can be located in two places named S1 and S2. Programming is prohibited when the selector plug is located in position S2 and enabled when the selector plug is in the position S1. The front panel can be dismantled by the four finger screws on the front panel.

Programming push-buttons

Parameter selector push-button ↓

With the parameter selector push-button the five programmable parameter groups are called up one by one. At the same time the previously selected parameter values are displayed. When all parameters have been stepped through, the fifth parameter pointer LED is switched off, the annunciator unit steps out of the programming mode.

Display cursor control push-button →

The cursor can be moved with the display cursor control push-button. The cursor always moves from the left to the right and the cursor position is indicated by blinking digit(s).

Parameter value selector push-button ↑

With the parameter value selector push-button the appropriate code number or data value for the concerned parameter is selected, i.e. for the digit(s) blinking.

Enter command push-button (Reset)

The selected data value is stored in the parameter memory with the enter command push-button. See figure 29 to locate the button.

Channel selector push-button ∩

The channel to be programmed is called up with the channel selector push-button. The channels are stepped through one by one from 1 to 16 and the channel to be programmed is indicated by its LED indicator glowing .

Channel related parameters

Selection of channel input delay

The pointer LED marked INPUT is called up with the parameter selector push-button ↓ and the channel to be programmed is chosen with the channel selector ∩. The cursor is moved to the leftmost digit of the display with the cursor control push-button →. The concerned digit starts blinking. The blinking number displayed corresponds to the following values of the channel input delay:

- 0 = 5 ms
- 1 = 20 ms
- 2 = 100 ms
- 3 = 1 s
- 4 = 5 s
- 5 = 20 s
- 6 = 60 s
- 7 = 160 s
- 8 = other time value set over the serial communication

The required value is chosen with the data value selector push-button - and stored in the parameter memory with the enter command push-button (Reset). The rest of the channels and their input delays can be programmed in the same way. Escape from the programming mode by repeatedly pressing the parameter selector push-button ↓ until all the parameter pointer indicators are switched off.

NOTE!

If no push-button has been pressed for a minute, the annunciator unit automatically escapes from the programming mode and enters into its normal operation mode.

Selection of channel resetting delay

The channel resetting delay is programmed in exactly the same way as the channel input delay (see above). The cursor is, however, located to the second digit from the left of the display,

which indicates the resetting delay time. The time values are also the same as those for the input delay.

Selection of field contact type or pulse counter

The LED marked INPUT is called up with the parameter selector push-button ↓ and the channel to be programmed is chosen with the channel selector push-button ∩. The cursor is moved to the third digit from the left of the display with the cursor control push-button →. The value corresponds to the following input signal types:

- 0 = input signal from a normally open field contact
- 1 = input signal from a normally closed field contact
- 2 = channel activated from a raising edge signal only
- 3 = channel activated from a falling edge signal only
- 4 = channel activated from a raising and falling edge signal

- 5 = Pulse counting on closing contact
- 6 = Pulse counting on opening contact
- 7 = Pulse counting on closing and opening contact

The chosen value is selected with the data value selector push-button ↓ and stored in the parameter memory with the enter command push-button.

NOTE!

Those channels which have been programmed to be activated by a raising or a falling edge signal are not to be linked to any other type of reflash group than to the AACR and ISR types. A channel which is controlled by an edge signal can be interlocked but it can not itself generate an interlocking signal to be forwarded.

Selection of channel-specified indications

The LED marked INPUT is called up with the parameter selector push-button ↓ and the channel to be programmed is chosen with the channel selector push-button ∩. The cursor is moved to the fourth digit from the left with the cursor control push-button →. The fourth digit expresses the type of indication as follows:

- 0 = normal sequence, i.e. the same operation sequence that has been selected for the whole annunciator unit (see section Selection of alarm sequence type on page 31)

- 1 = normal sequence, i.e. the same operation sequence as has been selected for the whole annunciator unit but extended with an audible ringback feature upon return to normal of an alarm channel. Applies only to the sequences 3 (ISA R-1) and 4 (DIN 19235),
- 2 = field contact following indication without audible alarm

The chosen value is selected with the data value selector push-button - and stored in the parameter memory with the enter command push-button.

Configuration of pumping supervision

The LED marked INPUT is called up with the parameter selector push-button ↓ and the channel to be included in the pumping supervision is chosen with the channel selector push-button ∩. The cursor control push-button → is pressed five (5) times and the first, third and fourth

digits are lit. The third and fourth digit expresses the pumping supervision as follows:

- 00 = pumping supervision not in use
- 01...99 = maximum allowed events per minute

Configuration of reflash group alarms

The LED marked GROUP is called up with the parameter selector push-button ↓ and the channel which is to be joined to a reflash group is selected with the channel selector push-button ∩. Then with the cursor control push-button → the cursor is moved to the first two digits from the left corresponding to channel reflash type A or to the last two digits corresponding to the channel reflash type B. The designated reflash group is selected with the data value selector push-button ↑, that is:

- 01 = output reflash group 1
- 02 = output reflash group 2

If required the channel reflash types A and B can both be programmed for the same channel. The selected reflash configuration is stored in the program memory using the enter command push-button.

Module related parameters	<p>The programming examples and selections above have all been channel specific which means that the parameters are selected individually for each channel. The function which will be described</p>	<p>in the following section is annunciator specific, which means that the selected function concerns the whole annunciator unit.</p>
<i>Selection of mode of operation for the reflash output relays</i>	<p>The LED marked OUTPUT is called up with the parameter selector push-button ↓ and the first two digits from the left of the display are activated with the cursor control push-button →. The blinking digits indicate, as listed below, which reflash group is being programmed at the moment, i.e.:</p>	<p>0 = field contact following reflash (FCFR) 1 = acknowledge action controlled reflash (AACR) 2 = impulse shaping reflash (ISR), impulse length 300 ms 3 = field contact following reflash with a 300 ms interruption of the reflash signal any time a new alarm signal joins into an already active group alarm 4 = FCFR + AACR, Field Contact Following Reflash and Action Controlled Reflash</p>
	<p>01 = output reflash group 1 02 = output reflash group 2</p>	
	<p>The reflash group in question is called up with the data value selector push-button ↑, after which the cursor is moved to digits three and four from the left of the display with the cursor control push-button →. The two digits are indicating the mode of reflash alarm signal for the selected output reflash group as follows:</p>	<p>See figure on page 12.</p>
		<p>The chosen reflash mode is selected with the data value selector push-button ↑ and stored in the parameter memory with the enter command push-button.</p>
<i>Selection of interlocking configuration</i>	<p>The interlocking configuration is channel specific, i.e. is done separately for each channel. A general overview of the channel interlockings is illustrated in figure 35 on page 34, which can be used to draw up the interlocking scheme when the channel interlockings are to be programmed.</p>	<p>When the required interlocking function has been selected, it can be linked to the chosen interlocking line by moving the cursor to the second digit from the left with the cursor control push-buttons →. The chosen interlocking line (1...8) is selected with the data value selector push-button ↑. If no interlocking function is needed, a - mark is selected in stead of the number of the interlocking line. The selected parameter values are stored in the memory by pressing the enter command push-button.</p>
	<p>The parameter selector push-button ↓ is repeatedly pressed until the LED marked INTERLOCK starts glowing. Select channels with the channel selector push-button ∩.</p>	
	<p>A maximum of two interlockings can be selected per channel. I.e. a channel can receive interlocking signals from two different interlocking lines (groups) or transmit one interlocking signal and receive one interlocking signal. The first two digits from the left in the display correspond to the first interlocking function and the digits three and four corresponds to the second interlocking function.</p>	<p>The selection relating to the second channel interlocking function is carried out in the same way as the selection of the first interlocking function, but in this case the third digit from the left of the display indicates the type of interlocking and the fourth digit states the corresponding interlocking line.</p>
	<p>If the first interlocking function is to be taken in use, the first digit from the left in the display indicate the type of interlocking, that is:</p>	<p>IMPORTANT! If more than three interlocking levels are used (i.e. a channel that blocks a channel that blocks a channel) the resolution of the time stamp of the events will be effected.</p>
	<p>0 = interlocking output 1 = interlocking input, reflash type A interlocked 2 = interlocking input, whole channel, return as an acknowledged alarm 3 = interlocking input, whole channel, return as a new alarm</p>	
	<p>See interlockings on page 15</p>	

The following example of an interlocking configuration relates to the figure on page xx.

At first INTERLOCK function is selected.
Channel 10 is called up.
The display is set to 010-, which is stored in the memory.
Channel 10 now activates interlocking Line 1.

Channel 8 is called up.
The display is set at 2102, which is stored in the memory.
Channel 10 now interlocks whole channel 8 (via the interlocking line 1) at the same time channel 8 activates interlocking line 2.

Then channel 7 is called up.
The display is set at 110-, which is stored in the memory.

Channel 10 now interlocks the reflash A of channel 7 via interlocking Line 1.

Then channel 5 is called up.
The display is set at 120-, which is stored in the memory.

Channel 10 now interlocks channel 8 which interlocks the channel reflash type A of channel 5 via interlocking line 2.

Selection of annunciator SPA bus slave address

The parameter selector push-button ↓ is repeatedly pressed until the LED marked MODULE starts glowing. The cursor is moved to the first two digits from the left of the display, using the cursor control push-button →. The SPA bus slave number (01...99) is selected for the annunciator unit with the data value selector push-

button ↑. The chosen slave number is entered into the parameter memory by pressing the enter control push-button.

NOTE!

No slave number is needed if the annunciator unit is not connected to a higher level system.

Selection of alarm sequence type

The selectable alarm sequences are illustrated on page xx. To select the chosen alarm sequence the parameter selector push-button ↓ is repeatedly pressed until the LED marked MODULE starts glowing. Using the cursor control push-button →, the cursor is moved to the third digit, seen from the left, which indicates the selectable alarm sequence types as follows:

- 0 = ISA A, automatic reset
- 1 = ISA A-1, automatic reset
- 2 = ISA M-1, manual reset
- 3 = ISA R-1, indication on return to normal
- 4 = DIN 19235, indication on return to normal

All sequence types but ISA A requires a separate reset of the audible alarm. The chosen sequence is selected with the data value selector push-button ↑ and stored in the parameter memory with the enter command push-button.

When the annunciator system is composed of several interconnected units, the flash sequence of the visual indicators can be synchronized. One of the annunciator units is defined as the master (1), thus delivering a synchronizing pulse to all the other interconnected annunciators (0). If the annunciator units are connected to a higher level system, the synchronizing pulses for the annunciator units are obtained automatically.

The parameter selector push-button ↓ is repeatedly pressed until the LED marked MODULE starts glowing. The cursor is then moved to the fourth digit from the left of the display with the cursor control push-button →. The fourth digit corresponds to one of the following functions:

- 0 = sync-pulse receiver, when not connected to a higher level system
- 1 = sync-pulse transmitter, when not connected to a higher level system
- 2 = 9600 bits/s serial communication
- 3 = 4800 bits/s
- 4 = 2400 bits/s
- 5 = 1200 bits/s
- 6 = 300 bits/s

The data value selector push-button ↑ is repeatedly pressed until the function aimed at is reached. The selected function is then stored in the parameter memory by pressing the enter command push-button.

If the annunciator unit is connected to a higher level system by means of a serial communication link or if the annunciator unit has been programmed to receive an externally generated synchronizing pulse and no synchronizing pulse is received within a time period of one minute, a visual indication in the form of a blinking decimal point will be switched on in the right-hand lower corner of the display. When no serial communication link is connected to the annunciator unit, the annunciator unit must be programmed to function in the sync-pulse receiver mode.

NOTE!

The parameters need not to be stored in the parameter memory one by one, but they can be stored all together at the same time, when they have been given their specified values in the display.

A summary of the programming parameters (figure 32) and empty parameter tables (figure 33 and 34) is given on the following pages.

DISPLAY				
PARAMETER				
⊗ Input Channel input settings	Channel input delay	Channel reset delay	Contact type	Channel indication
	0 = 5 ms 1 = 20 ms 2 = 100 ms 3 = 1 s 4 = 5 s 5 = 20 s 6 = 60 s 7 = 160 s	0 = 5 ms 1 = 20 ms 2 = 100 ms 3 = 1 s 4 = 5 s 5 = 20 s 6 = 60 s 7 = 160 s	0= NO contact 1= NC contact 2= NO contact, no return 3= NC contact, no return 4= NO and NC contact Pulse counters: 5= NO contact 6= NC contact 7= NO and NC contact	0= seq. 0-4 1= seq. 0-4 audible also at return to normal 2= field cont. following, no flashing, or audible
			Channel-related anti-pumping	
			00= supervision disabled 00...99= allowed number of registrations per minute	
⊗ Group Reflash grouping	Channel reflash A		Channel reflash B	
	-- = no group alarm 01= group alarm 1 - - 16= group alarm 16		-- = no group alarm 01= group alarm 1 - - 16= group alarm 16	
⊗ Interlock Configuration of interlockings	Interlocking function 1		Interlocking function 2	
	Type of interlocking	Interlocking group	Type of interlocking	Interlocking group
	0= interlocking output 1= channel reflash A interlocked 2= channel interlocked 3= channel interlocked	-- = not grouped 1= group 1 2= group 2 3= group 3 4= group 4 5= group 5 6= group 6 7= group 7 8= group 8	0= interlocking output 1= channel reflash A interlocked 2= channel interlocked 3= channel interlocked	-- = not grouped 1= group 1 2= group 2 3= group 3 4= group 4 5= group 5 6= group 6 7= group 7 8= group 8
⊗ Output Group alarm settings	Group alarm number		Type of reflash relay function	
	01= group alarm relay 1 02= group alarm relay 2 - - 16= group alarm relay 16		0= field contact following 1= alarm memory following 2= 300 ms pulse 3= 0 + 2	
⊗ Module Annunciator module settings	Unit identification number		Sequence	Serial comm.
	01= number 1 02= number 2 - - 99= number 99		0= ISA A 1= ISA A-1 2= ISA M-1 3= ISA R-1 4= DIN 19235	0= syncr. input 1= syncr. output 2= 9600 Bd 3= 4800 Bd 4= 2400 Bd 5= 1200 Bd 6= 300 Bd

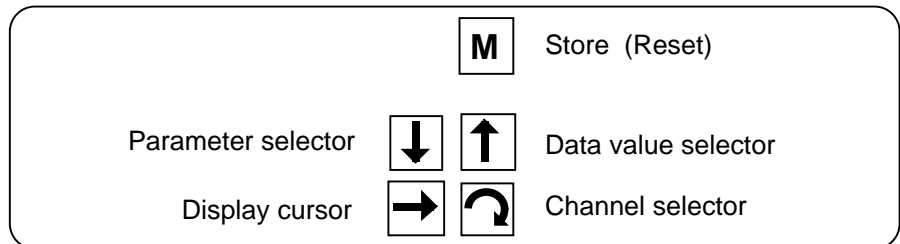

Fig. 32. Parameter selection key for annunciator unit SACO 16D1.

Alarm channel	Input				Group				Interlock			
	Channel input delay	Channel reset delay	Contact type	Channel indication	Channel reflash A		Channel reflash B		Interlock funct.1		Interlock funct.2	
									Type of interlocking	Interlocking group	Type of interlocking	Interlocking group
1												
2												
3												
4												
5												
6												
7												
8												
9												
10												
11												
12												
13												
14												
15												
16												

Output	
Group alarm number	Type of reflash relay function

Module		
Unit identification number	Sequence	Serial communication

Fig. 33. Parameter chart.

Channel interlocking scheme

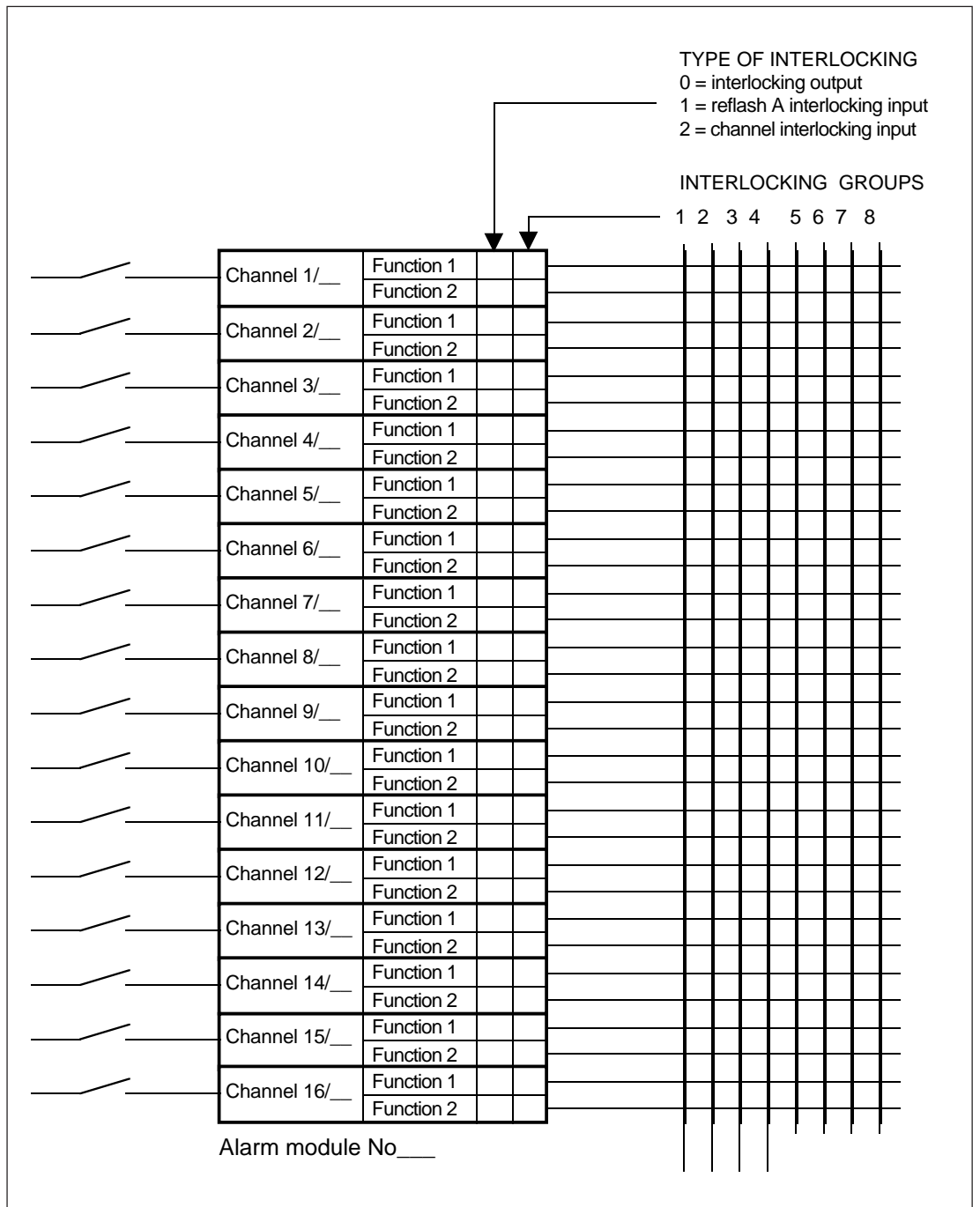

Fig. 34. Channel interlocking scheme for programming.

Remote information
to and from the
alarm annunciator

The following parameters can be read out or
written down to the annunciator unit from a
higher level device.

Code	Factory setting	Value and function
Module related parameters		
V205	-	Program version
S1	0	Reflash output 1 sequence 0 = FCFR 1 = AACR 2 = ISR 3 = FCFR + ISR 4 = FCFR + AACR
S2	0	Reflash output 1 sequence
S17	3	Alarm sequences 0 = ISA A 1 = ISA A-1 2 = ISA M-1 3 = ISA R-1 4 = DIN 19235
S18	0	Specification of active channels to be printed out as a result when parameter A is read out 0 = both alarm and status channels are printed out 1 = only alarm channels are printed out 2 = no out printing
S19	0	Pumping supervision output relay 00 = not connected 01 = output relay 1 02 = output relay 2
S33	0	Control of the output relay 1 over the SPA bus 0 = not active 1 = changing of state (on/off) 2 = pulse activation
S34	0	Control of the output relay 2 over the SPA bus
S49	0	Pulse length of output relay 1 0,3...25,5 = pulse length in seconds
S50	0	Pulse length of output relay 2
V1	-	Position of local/remote position 0 = local + remote position 1 = local position 2 = remote position
V2	-	Resetting of audible alarm output 1 = reset
V3	-	Acknowledge of alarm signal 1 = acknowledge
V4	-	Testing 0 = testing off 1 = testing on

Code	Factory setting	Value and function
V50	-	Status information of all 16 channels, HEX coded form 0000 = no active channels 0001 = channel 1 active 0002 = channel 2 active 0003 = channel 1 and 2 active 0004 = channel 3 active 0005 = channel 1 and 3 active 0006 = channel 2 and 3 active 0007 = channel 1,2 and 3 active 0008 = channel 4 active 0009 = channel 1 and 4 active 000A = channel 2 and 4 active 000B = channel 1,2 and 4 active 000C = channel 3 and 4 active 000D = channel 1,3 and 4 active 000E = channel 2,3 and 4 active 000F = channel 1,2,3 and 4 active - - - FFFF = all 16 channels active
V51	-	Status information of the overflow matrix register, HEX coded form 0000 = no active channels 0001 = channel 1 active 0002 = channel 2 active 0003 = channel 1 and 2 active 0004 = channel 3 active 0005 = channel 1 and 3 active 0006 = channel 2 and 3 active 0007 = channel 1,2 and 3 active 0008 = channel 4 active 0009 = channel 1 and 4 active 000A = channel 2 and 4 active 000B = channel 1,2 and 4 active 000C = channel 3 and 4 active 000D = channel 1,3 and 4 active 000E = channel 2,3 and 4 active 000F = channel 1,2,3 and 4 active - - - FFFF = all 16 channels active
V100	-	Reset of alarm channel 1 = reset
V151	-	Storing of information in non-volatile memory 1 = storing
V200	-	Module SPA slave address 1...99 = address number 1...99

Code	Factory setting	Value and function
V201	2	Setting of the data transfer rate 0 = 9600 bits/s, synch in 1 = 9600 bits/s, synch out 2 = 9600 bits/s 3 = 4800 bits/s 4 = 2400 bits/s 5 = 1200 bits/s 6 = 300 bits/s
I1	-	State of interlocking line 1 0 = not active state 1 = active state
I2	-	State of interlocking line 2
I3	-	State of interlocking line 3
I4	-	State of interlocking line 4
I5	-	State of interlocking line 5
I6	-	State of interlocking line 6
I7	-	State of interlocking line 7
I8	-	State of interlocking line 8
O1	-	State of output relay 1 0 = not active state 1 = active state
O2	-	State of output relay 2
C	0	Status information of module 0 = when read normal state, when written resets the status register 1 = CPU reset has occurred 2 = overflow of the event register has occurred 3 = 1 + 2
F	SACO 16D2B	Type designation of module
T	-	Time setting 0.000...59.999 = time in seconds and milliseconds
L	-	Event sequence register Time, channel and event code
B	-	Repeated read out of event register Time, channel and event code
A	-	Active alarms Channel number and event code
Channel related parameters (alarm channels 1...16)		
S1	0.02	Channel input delay 0.005...160.0 = reset delay 0.005 s steps
S2	0.02	Channel reset delay 0.005...160.0 = reset delay 0.005 s steps

Code	Factory setting	Value and function
S3	0	Field contact type 0 = NO contact, with return function 1 = NC contact, with return function 2 = raising edge only 3 = falling edge only 4 = raising and the falling edge 5 = pulse counter, counts by contact closing 6 = pulse counter, counts by contact opening 7 = pulse counter, counts by contact opening and closing
S4	0	Channel related sequence 0 = visual indication in accordance with selected sequence 1 = visual indication in accordance with selected sequence, but with audible alarm also on return to normal 2 = field contact following visual indication without audible alarm
S5	0	Channel reflash A 0 = not connected 1 = connected to reflash group 1 2 = connected to reflash group 2
S6	0	Channel reflash B 0 = not connected 1 = connected to reflash group 1 2 = connected to reflash group 2
S7	0	Interlocking signal 1, type specification 0 = interlocking output 1 = interlocking input, reflash A blocked 2 = interlocking input, entire channel, return as acknowledged alarm 3 = interlocking input, entire channel, return as new alarm
S8	0	Interlocking signal 1, grouping 0 = not connected 1...8 = connected to interlocking line 1...8
S9	0	Interlocking signal 2, type specification 0 = interlocking output 1 = interlocking input, reflash A blocked 2 = interlocking input, entire channel, return as acknowledged alarm 3 = interlocking input, entire channel, return as new alarm
S10	0	Interlocking signal 2, grouping 0 = not connected 1...8 = connected to interlocking line 1...8
S11	0	Pumping supervision 0 = not connected 1...99 = allowed events per minute
V5	0	Pulse counter 0...29999 = start value
I1	-	Sate of alarm channel 0 = not active 1 = active

Code	Meaning
------	---------

 Module related event codes

E10	Module fault
E13	Events from the overflow matrix register
E50	Module reset
E51	Event register overflow

Channel related event codes

E1	Alarm channel active
E2	Alarm channel reset
E3	Alarm channel active, signal follower, no blink- or audible functionality
E4	Alarm channel reset, signal follower

Technical data**Alarm channels**

Number of alarm channels	16 channels
Type of field contact signal	Normally open contact *) Normally closed contact Raising and/or falling edge Pulse counter
Internally generated field contact voltage	48 V dc + 20 %
Loop current of closed field contact circuit	4 mA ±20%
Channel input and reset delay time, field-selectable	5 ms, 20 ms *), 100 ms, 1 s, 5 s, 20 s, 60 s or 160 s Other values possible over the serial communication
Max. counting frequency for pulse counter	3 Hz

*) = factory settings

External acknowledge/reset inputs

Channel acknowledge/ reset	Closing contact
Reset of audible device	Closing contact
The control voltage for the acknowledge/reset circuits is taken from the internal supply	48 V dc + 20 %

Reflash signal outputs

Reflash group alarm outputs	2 relays
Audible device output	1 relay
Internal self-supervision output	1 relay
Output relay contact types	Normally open contacts, changeable to normally closed contacts
Rated contact current/breaking voltage	3 A/250 V
Breaking capacity for dc currents when the load time-constant L/ R < 40 ms at the voltage levels 48/110/220 V dc	3 A/0.25 A/0.15 A

Serial communication port

Protocol	SPA bus
Interface	RS 485
Data interchange speed, selectable	9600 Baud 4800 Baud 2400 Baud 1200 Baud 300 Baud
Bus connection modules	SPA-ZC 17 or SPA-ZC 21

Auxiliary power supply

Internal power unit for any supply voltage	80. . .265 V dc or ac or 18...80 V dc
Power demand from auxiliary source, min. /max. values	10 W/15 W

Test voltages

Test voltages applied to the following points:

- alarm- and acknowledge/reset inputs to the frame
- output relay contacts to the frame
- auxiliary supply circuits to the frame
- inputs, outputs and supply circuits between themselves

Dielectric test voltage as per IEC 255-5 and SS 436 15 03	2 kV, 50 Hz, 1 min.
Impulse test voltage as per IEC 255-5 and SS 436 15 03	5 kV, 1.2/50 ps, 0.5 J
High-frequency interference test voltage as per IEC 255-6 and SS 436 15 03	2.5 kV, 1 MHz

Environmental conditions

Service temperature range	-10. . . +55°C
Storage temperature range	-40. . . +70°C
Heat and damp as per I EC 68-2-3	< 95 % max. 56 d/y at +40 C
Degree of protection by enclosure	IP 54
Weight	3.1 kg

Testing

The alarm annunciator unit is provided with an automatic self-supervision system which monitors the internal system voltages as well as the function of the microprocessor and the logical circuits.

If an internal fault situation is detected, the contact of the output relay of the self-supervision system drops off and the FAULT LED is switched on.

The LED indicators can be tested by pressing the acknowledge/reset push-button continuously for more than one second. Then all LED indicators, except the FAULT indicator, on the front panel are switched on together with all the segments of the digital display. If the push-button is depressed for more than 15 seconds, the FAULT indicator also turns on and the output relay of the self supervision system drops off.

It is recommended that the function of the field contact circuits are tested by performing primary tests to the field contacts.

Maintenance and repair

When the annunciator unit is operating under normal service conditions as specified in the section "Technical data", the annunciator unit is practically maintenance free. The modules include no parts or components, which are subject to an abnormal physical or electrical wear under normal operating conditions.

If the environmental conditions at the operating site differ from those specified, as to ambient temperature, humidity or if the atmosphere around the annunciator unit holds chemically active gases or dust, the modules ought to be visually inspected in association with the secondary testing being performed or whenever the plug-in modules are withdrawn from the case. At the visual inspection the following things should be noted:

- possible mechanical damage of the mounting case, mounting brackets or frame, plastic lid or its rubber gasket, plug-in units or their connection sockets
- signs of oxidation on the PCBs, component legs and cups, screws and other metallic parts
- traces of dust and dirt accumulating inside the plastic lid, on the PCB or inside the case. Check the condition of the rubber gasket of the lid.

If the annunciator unit fails in operation or if the operating values differ from those specified, the annunciator unit should be checked and repaired by a competent specialist in an authorized repair shop.

Generally a fault can be eliminated by changing a plug-in module, please refer to the spare part list. When a new alarm module SWPA 3A1 is inserted, the programmed parameter memory of the old alarm module can be plugged to the new module. Thus the new alarm module is ready to work with the same operating values as the old one without being separately programmed. The parameter memory is marked D17.

IMPORTANT!

When the memory circuit is plugged in, the slot on the circuit should point towards the front panel of the module. In this way possible damage of the memory circuit can be avoided. Please always use EDS protection when handling the electronic circuit

**Exchange and
spare parts**

Alarm module	SWPA 3A1
Input and output module	SWIM 2A1
Connection module, the whole rear unit	SWCM 3A1
Supply module, U = 80. . .265 V dc/ac	SPGU 240A1
Supply module, U = 18...80 V dc	SPGU 48B2
Alarm legend film, unwritten	SYKU 639

Bus connection modules

RS 485 with two 9-pin D-type connectors	SPA-ZC3
Fiber optical module, plastic out - plastic in	SPA-ZC 21 BB/S
Fiber optical module, glass out - glass in	SPA-ZC 21 MM/S
Fiber optical module, plastic out - glass in	SPA-ZC 21 BM/S
Fiber optical module, glass out - plastic in	SPA-ZC 21 MB/S
Fiber optical module, plastic out - plastic in	SPA-ZC 17 BB/S
Fiber optical module, glass out - glass in	SPA-ZC 17 MM/S
Fiber optical module, plastic out - glass in	SPA-ZC 17 BM/S
Fiber optical module, glass out - plastic in	SPA-ZC 17 MB/S

Raising frames

Raising frame, 40 mm	SPA-ZX 101
Raising frame, 80 mm	SPA-ZX 102
Raising frame, 120 mm	SPA-ZX 103



ABB Oy

Substation Automation

P.O.Box 699

FIN-65101 VAASA

Finland

Tel. +358 (0)10 22 11

Fax.+358 (0)10 22 41094

www.abb.com/substationautomation