



# E 90 range of fuse disconnectors and fuseholders

Uncompromising performance

# Designing simplicity

## ABB competence serving the most demanding customers

Suitability for disconnection and switching, effective heat dissipation and certified compliance with several international standards are mandatory requirements to meet the needs of the most demanding customers. ABB has dedicated its designers' passion, competence and creativity to the development of E 90 new range of disconnectors and fuseholders.

The result is the first AC-22B fuse disconnector, certified up to 32 A by the most outstanding marks and approvals all over the world.

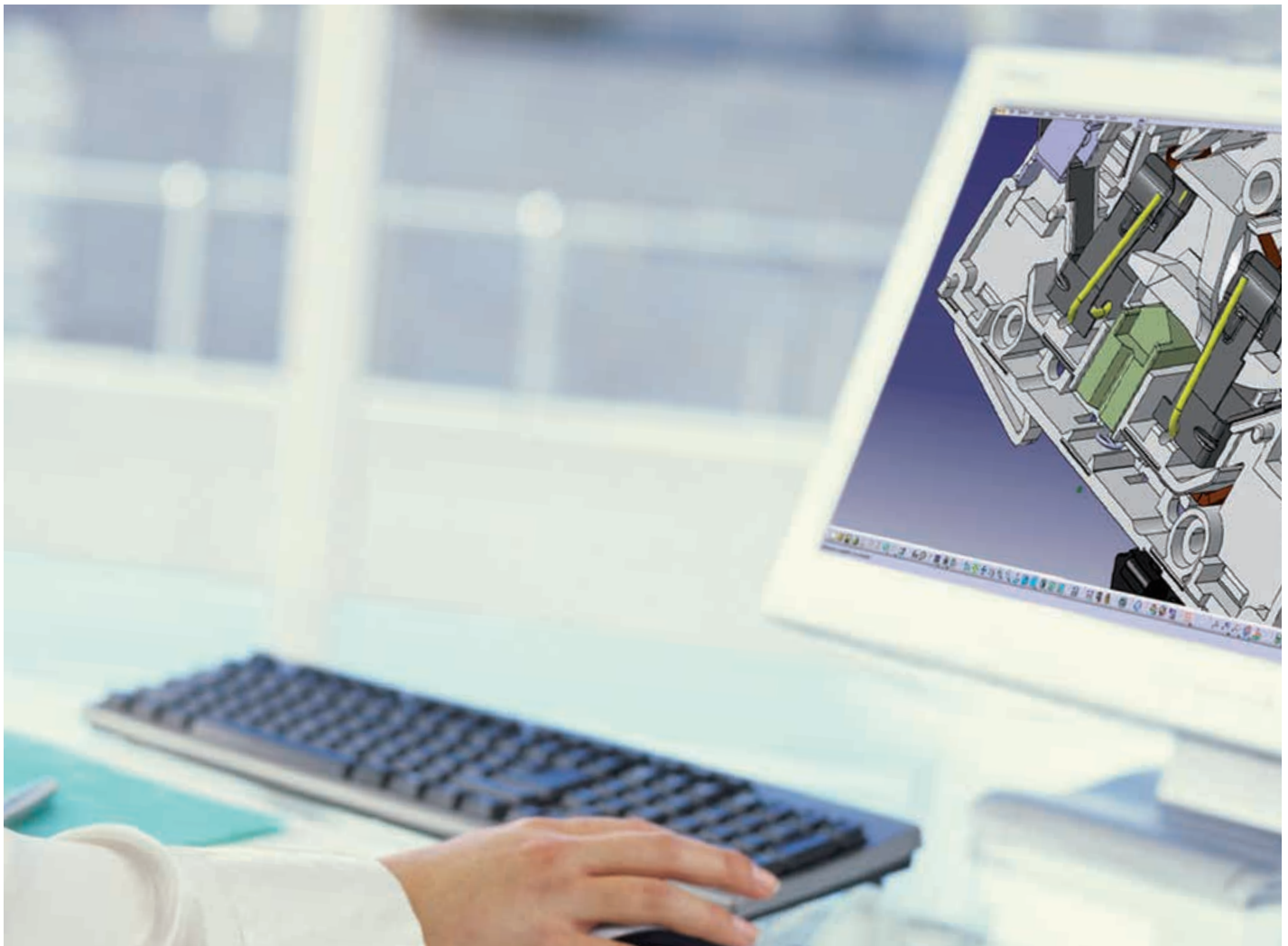

# The new ABB standard Certified according to the most important international marks



A passport to the world.  
International quality marks, naval type-approvals and UL certification  
make E 90 the ideal range for designers and manufacturers of  
switchboards and installations “without frontiers”.

# E 90 range

## Designed by ABB for the most demanding customers

### Industrial automation E 90 fuse switch disconnectors

- One module per pole
- Versions 1, 1N, 2, 3, 3N, 4
- AC-22B according to IEC 60947-3
- Rated current 20 A and 32 A
- Rated voltage 400 V AC-22B and 690 V AC-20B
- Can be equipped with 8.5 x 31.5 mm and 10.3 x 38 mm aM and gG fuses
- Designed for isolation and switching under load and for protection of secondary circuits of industrial plants
- All the versions are available with optical blown fuse indicator
- Compatible with ABB busbars of S 200 series and Unifix plug-in system
- cURus certification

### Distribution switchboards E 90h fuseholders

- One pole plus neutral in one module
- Versions 1N, 3N
- Certified according to IEC 60269-3
- Rated current 20 A and 32 A
- Rated voltage 400 V AC
- Can be equipped with 8.5 x 31.5 mm and 10.3 x 38 mm aM and gG fuses
- Designed for instruments and auxiliaries protection in switchboards and consumer units
- All the versions are available with optical blown fuse indicator
- Compatible with ABB busbars of SN 201 series and Unifix plug-in system

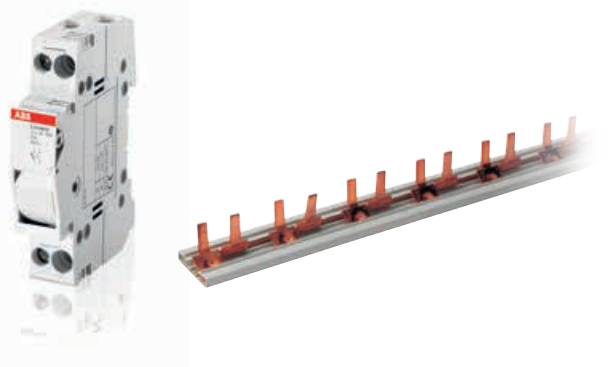
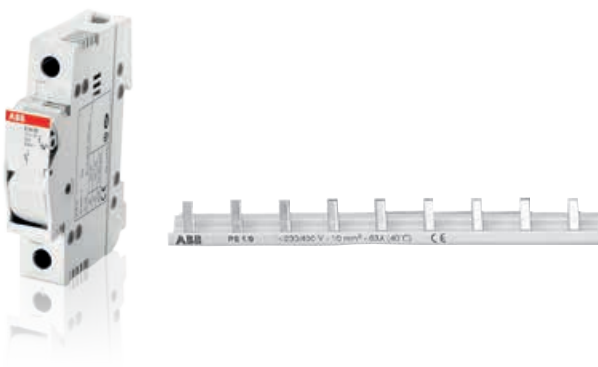
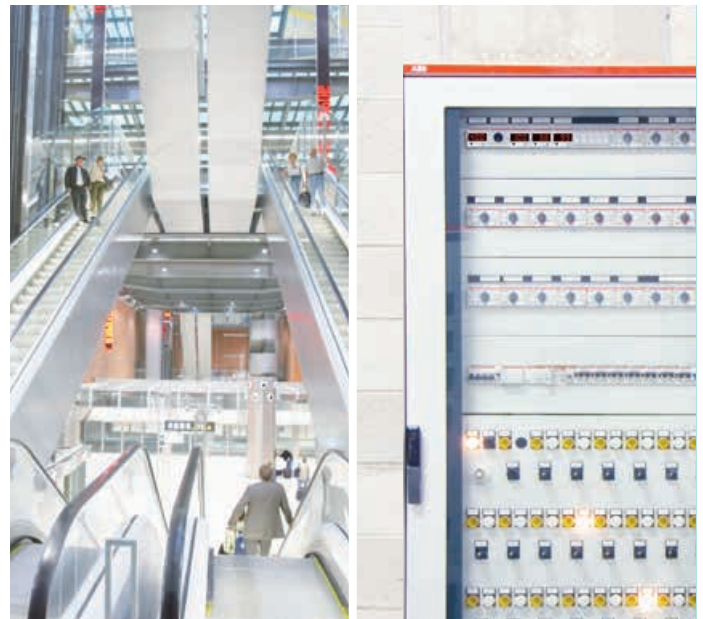
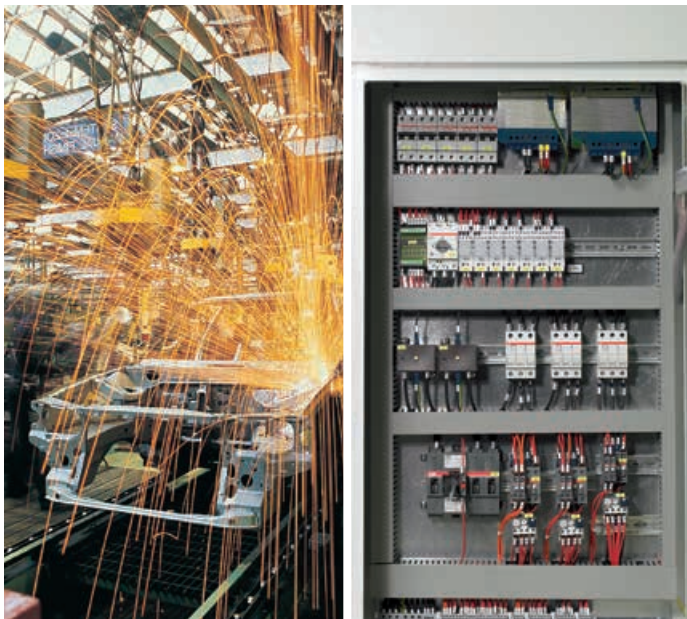

## Photovoltaic installations E 90 PV fuse disconnectors

- One module per pole
- 1 and 2-pole versions
- DC-20B according to IEC 60947-3
- Rated current 32 A
- Rated voltage 1000 V DC
- Can be equipped with 10.3 x 38 mm gPV fuses
- Designed for isolation and protection of circuits in photovoltaic installations up to 1000 V DC
- All the versions are available with optical blown fuse indicator
- Certified according to UL 4248-18
- Compatible with UL-508 busbars



## For the American market E 90 CC fuseholders

- One module per pole
- Versions 1, 1N, 2, 3, 3N, 4 poles
- Rated current 30 A
- Rated voltage 600 V AC/DC
- Can be equipped with Class CC fuses
- Specifically designed for North American market
- All the versions are available with optical blown fuse indicator
- Certified according to UL 4248-4
- Compatible with UL-508 busbars
- Rejection member feature according to UL 4248-4

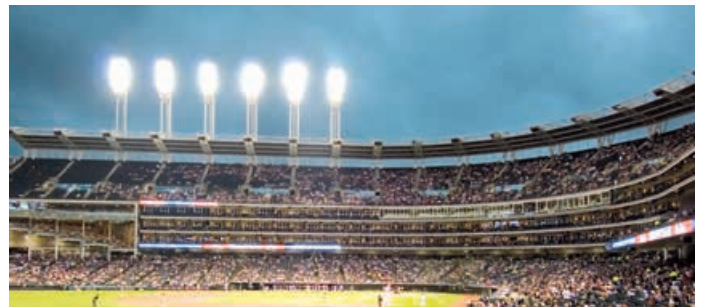

# Choosing the best ABB experience sets a new leading-edge performance standard

## Tip-top performance

E 90 fuseholders can be used in any applications where you need to ensure electrical protection, isolation and switching under load of inductive or resistive loads in compliance with IEC 60947-3 Standard, AC-22B utilization category. The technology solutions applied to reduce power dissipation help to minimize module heating.

## Completeness

The fuse tripping can be easily displayed, thanks to the special blown fuse indicator light.

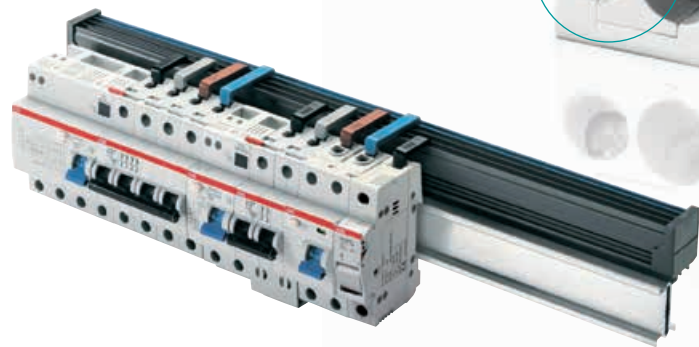

Ease of installation.  
E 90 fuseholders are fully compatible  
with the Unifix-L wiring system

## Reliability

Venting grooves and cooling chambers improve heat dissipation even in multiple-pole configurations. The reduced operating temperature inside fuseholders ensures durability and reliability of the devices over time.

## Compactness

When open, the drawer projection is only 17 mm more than in the normal closed position.

The compact dimensions enable to close the switchboard door even when the fuseholder is open, thus ensuring total safety during maintenance. 1P+N versions in one module only and 3P+N in three modules only are available.

## Universal use

Screw holes have increased diameter to accommodate insulated screwdrivers and electric screwdrivers. In addition, with the Pozidrive PZ2 screws tightening can be performed by exerting less torque than conventional screws, and the same electric screwdriver can be used for all terminals. Moreover, the PS connection busbars facilitate the connecting operations, making the wiring both simple and safe and providing complete integration with S 200 and SN 201 System pro M compact® circuit-breakers.

E 90 safe and smart range is designed for quick, flexible and error-proof installation, to ease the everyday use of devices. Thanks to its unique features, E 90 series sets a new safety standard.

## Reliable connections

Wide terminals allow the use of cables with section up to 25 mm<sup>2</sup>, whereas the antivibration knurling on the terminal cages ensures safe and reliable connections.

## Ease of use

Fuseholder profile has been designed for maximum ease of use: the 90° flip hinge with ergonomic knob, makes the replacement of fuses easier even in small spaces or when wearing protective gloves.

## Safety

To ensure protection and safety during maintenance operations and avoid any accidental switching, fuseholders can be sealed in closed position, and padlocked in open position. The protection degree is IP20 when the unit is installed behind the switchboard slotting.

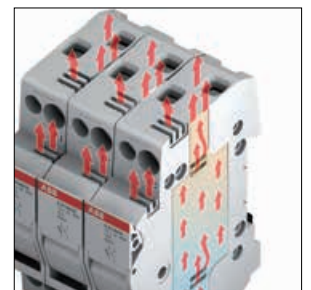
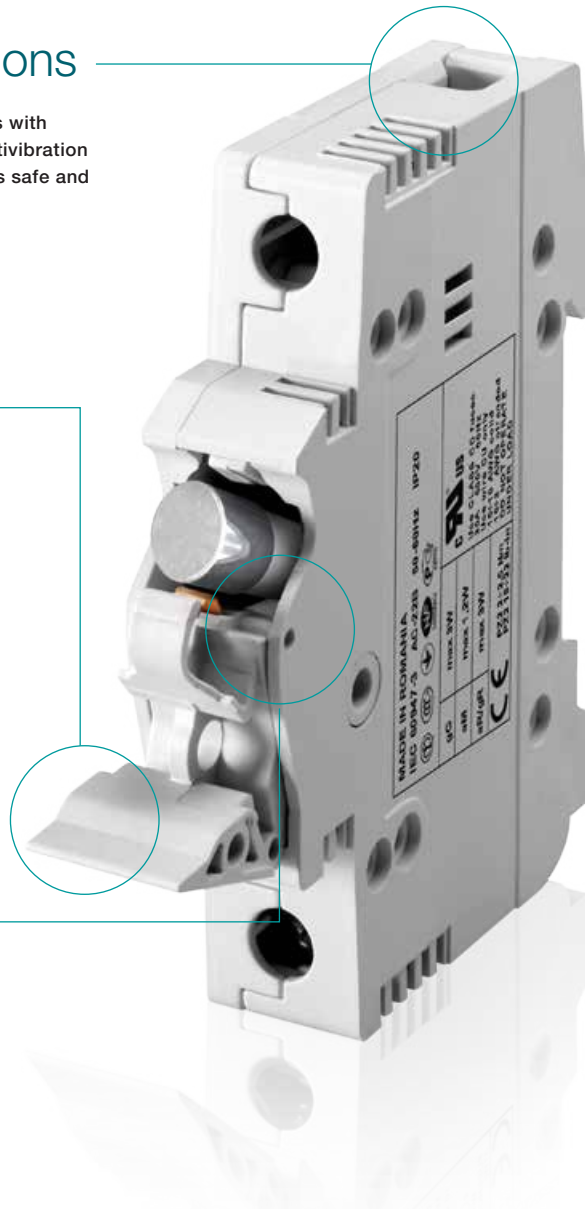

## Environmental protection.

The fuseholders are compliant with RoHS (Restriction of Hazardous Substances) European directive, which prohibits the use of hazardous substances in the manufacture of electrical and electronic equipment.





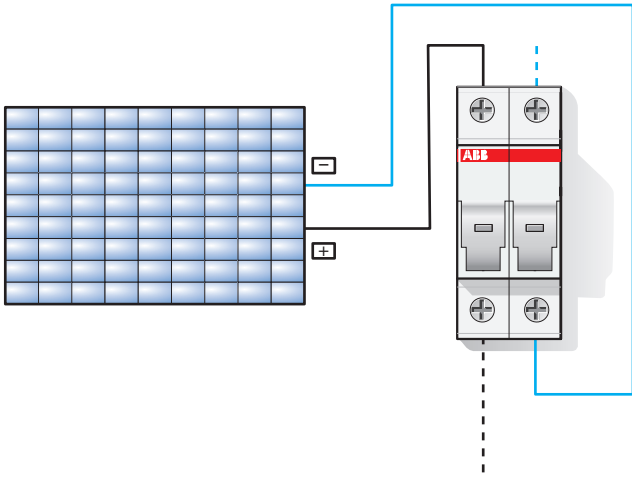

Wiring diagram for d.c. networks

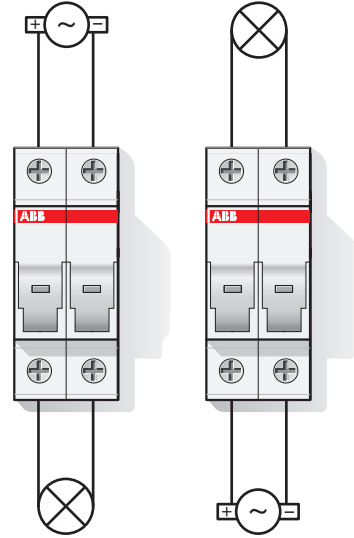

Wiring diagram for a.c. networks

## E 90 Wizard

E 90 Wizard is an APP to easily select fuse and fuse holder codes in few simple steps wherever you are.

E 90 Wizard helps you to select ABB codes for E 90 and E 9F series for all the applications: industrial, residential, photovoltaic and North American markets. In few taps E 90 Wizard can provide you the right code, listing you technical characteristics and documentation links.



# Results you can trust High performance of E 90 fuse disconnectors



# E 90 protection and control

## A range developed for automation and industry

### Applications

- Automation switchboards
- On-board switchboards
- OEM

### Main functions:

- Protection of terminal circuits
- Switching of loads, even inductive
- Selectivity



E90 fuse disconnectors are designed for switching under load, ensuring isolation and protection against short circuit and overload, in compliance with the IEC 60947-3 Standard.

E 90 range is designed to comply with the strictest requirements of OEMs and panel builders. They are ideally installed in industrial automation switchboards to protect secondary circuits, primary and secondary of transformers, motors and other resistive or inductive loads. Due to the AC-22B utilization category up to 400V, according to the IEC 60947-3 Standard, E 90 fuse disconnectors are convenient, simple and reliable devices for loads switching and protection. Fuse disconnectors ensure selectivity, if equipped with appropriate fuses. Since they are uURus type-approved, they can be installed in UL-certified machines designed for the American market.

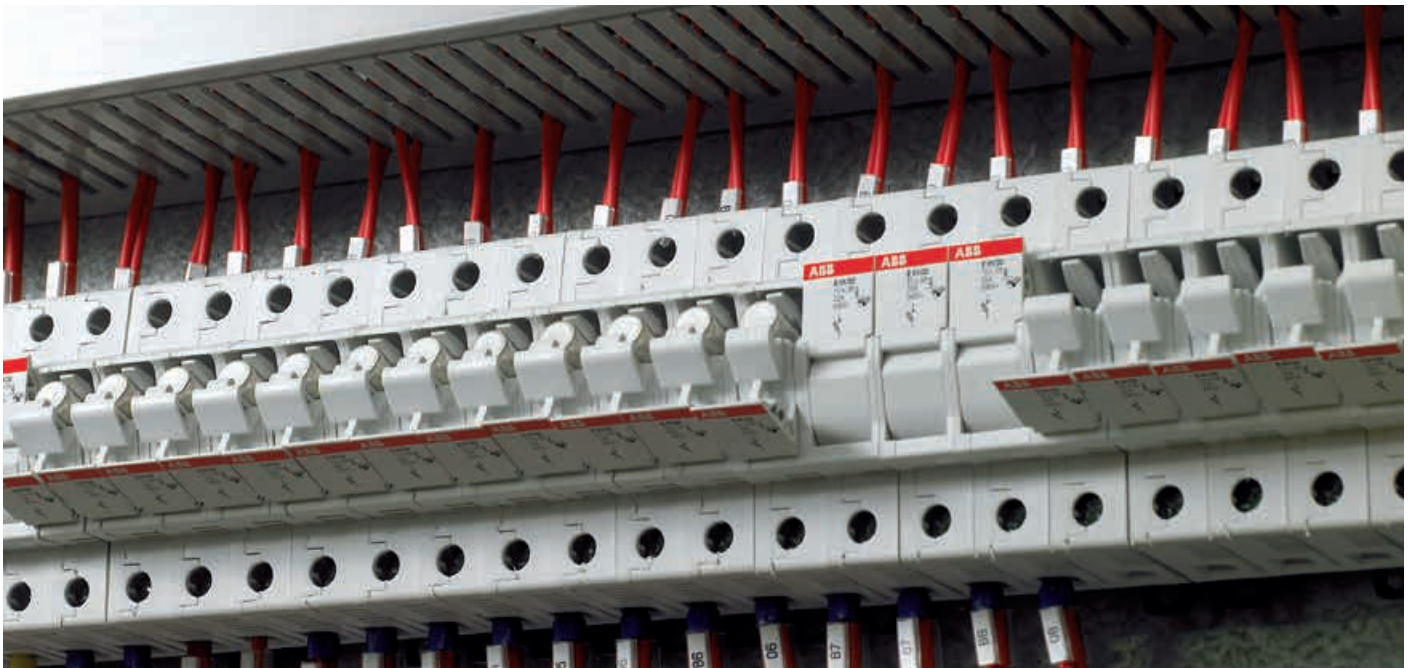

### Application example

Here you can find a typical industrial control application. According to IEC 60364-1 Standard, the secondary winding of a control transformer must be protected against short circuits and overload. The transformer provides dedicated 230 V a.c. power supply to a battery of industrial contactors.

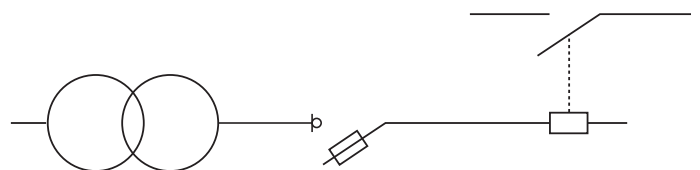

# Industrial distribution E 90h fuseholders: ideal for distribution switchboards



# E 90h fuseholders

## Compact protection of electric auxiliaries in distribution switchboards

### Applications

- Distribution switchboards
- Consumer units

### Terminal protection of of:

- Electric auxiliaries
- Switchboard instrumentation
- Surge arresters

E90 Fuseholders – 1P+N in one module and 3P+N in three modules, respectively – are very compact in size and are the most suitable solution for protection of circuits and devices inside switchboards.

E 90h range is designed for protecting electrical devices both in single phase and in three-phase networks with neutral. They are particularly suitable inside switchboards and consumer units for protecting lighting circuits, modular sockets and electrical devices for monitoring, measuring and signalling.



### Application example

Here you can find a typical application inside a secondary distribution switchboard. Following the manufacturer's instruction, the voltmeter inputs of the multimeter are protected with fuses.

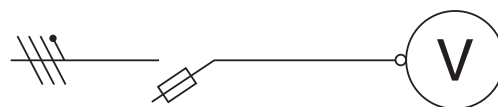

# E 90 PV fuse disconnectors for photovoltaic applications Designed for industry professionals

## Features

- For 10.3 x 38 mm fuses
- Rated voltage 1000 V DC
- Rated current 32 A
- DC-20B Utilization category
- Reference standards:  
IEC 60947-3 UL 4248-18

E 90 PV fuse disconnectors have been specifically designed for photovoltaic applications. Thanks to their rated voltage up to 1000 V d.c. they are the ideal solution for protecting cells, inverters or surge arresters. In case of maintenance, they ensure isolation of circuits and strings up to 1000 V in direct current, in total safety.



# Isolation and protection of strings up to 1000 V

## Application examples

### String protection

To prevent damage to the equipment in the direct current lines of photovoltaic installations and ensure that it remains **isolated** when maintenance work is performed, E 90 PV fuse disconnectors can be installed downstream of the inverter so as to protect each string. The fuses must be selected to suit the rated current of the line.

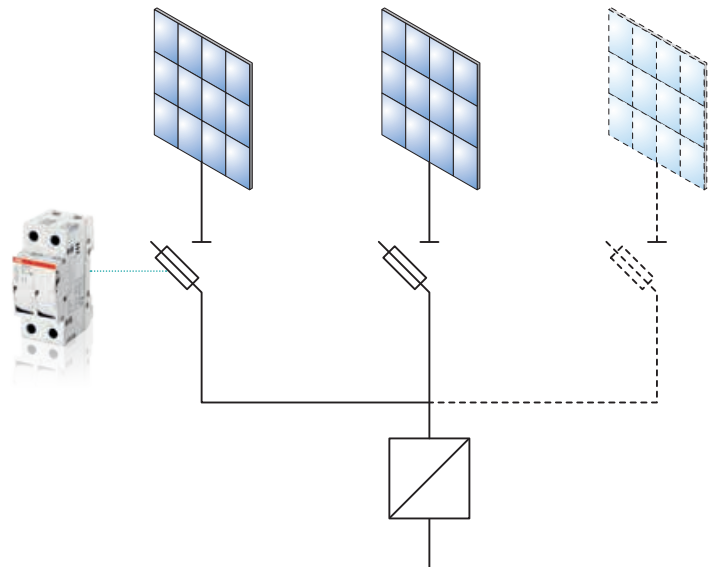

### Surge arrester back-up

When the lcc short-circuit current at the installation point exceeds 100 A DC, **OVR PV** surge arresters require back-up protection with a specific gR-type fuse.

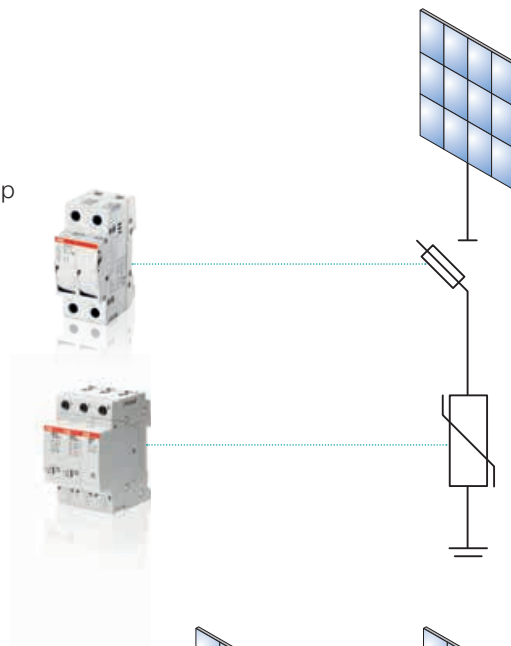

### D.c. side of the inverter

In small photovoltaic installations, E 90 PV fuse disconnectors can be used to protect the direct current side of the inverter. Fuse cartridges should be selected according to the inverter rated current.

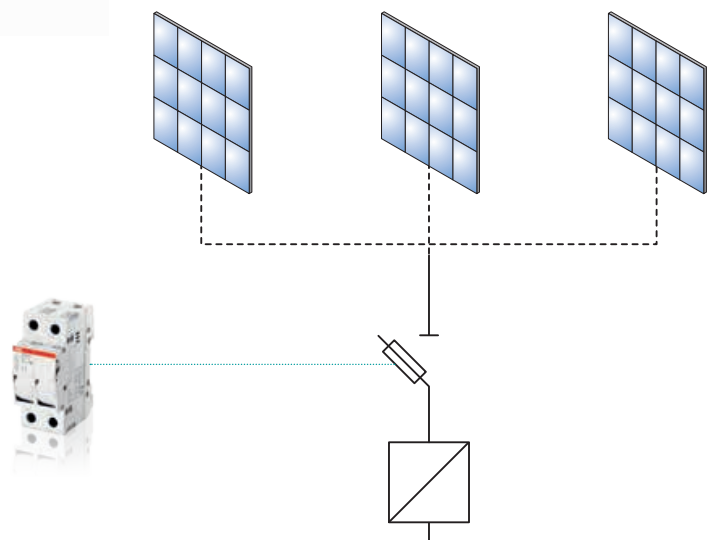

# Quality also speaks American E 90 CC fuseholders, designed for the North American market

## Features

- UL Listed according to UL 4248-1 and UL 4248-4
- Can be equipped only with Class CC fuses
- Rated voltage 600 V AC/DC
- Rated current 30 A
- Versions 1, 1N, 2, 3, 3N, 4 poles
- Rejection member to allow just the insertion of a class CC fuse



E 90 CC range has been designed to comply with North American market regulations and to enable worldwide manufacturers to sell their equipment in conformity with safety requirements also in these countries.

Class CC fuses have limiting characteristics dedicated to terminal protection of components and apparatuses against short-term overloads and to protect motor against short-circuit. Maximum rated current of a Class CC fuse is 30 A, whereas the maximum rated voltage is 600 V. The breaking capacity reaches 200 kA. The limiting properties of the Class CC fuses are particularly appreciated in the North American market, allowing suitable protection even of equipment with limited resistance to short-circuit. The use of Class CC fuses is continuously increasing in the American market, since the safety and reliability prescriptions of end users have become stricter and do not tolerate any permanent damage to motor starts.





# E 930 fuse disconnectors

## Protection for industrial circuits

### Features

- For 14x51 and 22x58 mm fuses
- 690 V AC/DC according to IEC and 750V AC/DC according to UL
- UR and CSA type-approved



E 930 fuse disconnectors are specifically designed for protecting industrial circuits thanks to aM and gG cylindrical fuses with 50 A and 125 A ratings.

E 930 range can be padlocked in the open position to ensure safety for operators performing maintenance work. Moreover, they also support MCR microswitches thanks to which the status of the device can be fully monitored from remote. The microswitch is able to provide an indication when the fuse blows, if the drawer is open and if it has been closed without inserting the fuse. Microswitch functionalities are guaranteed only using fuses with striker pin. More technical details can be found at pag. 43.

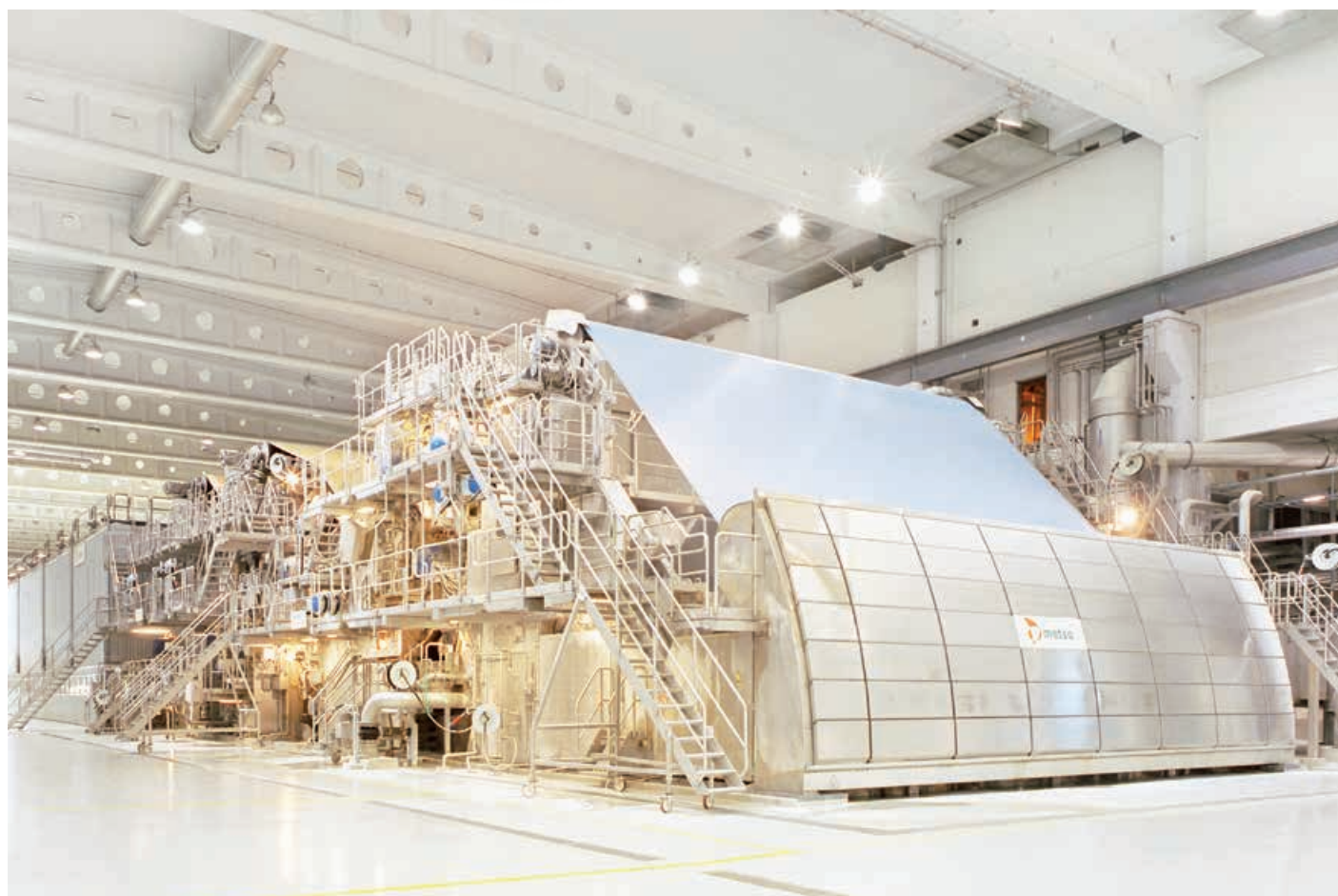

# Technical data

## E 90 series

### Data according to IEC

Type		E 90/20	E 90/32	E 90hN/20	E 90hN/32	E 90/32 PV	E 930/50	E 930/125
Rated current	A	20	32	20	32	32	50	125
Type of current		AC		AC		DC	AC/DC	
Fuse	mm	8 x 31	10 x 38	8 x 31	10 x 38	10 x 38	14 x 51	22 x 58
Max power dissipation accepted	W	2,5	3	2,6	3,2	3	5	9,5
Rated frequency	Hz	/ 50-60		/ 50-60		–	= / 50-60	
Tightening torque	Nm	PZ2 2-2,5		PZ2 0,8-1,2		PZ2 2-2,5	PZ2 3,5	PZ2 4
Protection degree		IP20		IP20		IP20	IP20	
Terminals' section	mm <sup>2</sup>	25		16		25	35	50
Cross section rigid copper conductors	mm <sup>2</sup>	1,5 - 25		1,5 - 16		1,5 - 25	2,5 - 35	4 - 50
Cross section stranded copper conductors	mm <sup>2</sup>	1,5 - 16		1,5 - 10		1,5 - 16	2,5 - 25	4 - 35
Operating temperature	°C	-5 / +40***		-5 / +40***		-5 / +40***	-5 / +40***	
Storage temperature	°C	-25 / +70****		-25 / +70****		-25 / +70****	-25 / +70****	
Altitude	m	2000		2000		2000	2000	
Voltage range for LED indicator light		24 - 1000 AC/DC (only s version)		–	–	24 - 1000 AC/DC (only s version)	24 - 1000 AC/DC (only s version)	
Padlockable (when open)		•	•	•	•	•	•	
Sealable (when closed)		•	•	•	•	•	•	

#### IEC 60947-3

Utilization category		AC-22B	AC-20B	AC-22B	AC-20B	–	DC-20B	AC-20B / DC-20B	
Rated voltage	V	400	690	400	690	–	1000	690	690

#### IEC 60269-3

Rated voltage	V	–			400	400	–	–	–
---------------	---	---	--	--	-----	-----	---	---	---

Marks and approvals	E 90/20	E 90/32	E 90hN/20	E 90hN/32	E 90/32 PV	E 930/50	E 930/125
IMQ	•*(1)	•*(1)	•*	•*			
NF	•**(1)	•**(1)					
CCC - Cina	•*(1)	•*(1)	•*	•*			
cURus		•(2)					
UR							•
UL					•(3)		
CSA							•
RINA	•*(1)	•*(1)	•*	•*			
LLOYD	•*(1)	•*(1)	•*	•*			
BV	•(1)	•(1)	•	•	•		•
GOST - Russia	•	•	•	•	•		•
GOST - Ukraina	•	•	•	•	•		•

•\*= without LED version

•\*\* = no neutral and without LED version

\*\*\*= for lower temperature verify fuse technical characteristics, for higher temperature refer to derating table at page 25

\*\*\*\*= for more than 24h max temperature is +55°C

(1) = certified AC-22B at 400V in compliance with IEC 60947-3

(2) = certified at 600V in compliance with UL 4248-4

(3) = certified at 1000V in compliance with UL 4248-18

## Data according to UL

Type		E 90/30 CC	E 90/32 PV
Rated current	A	30	32
Rated Voltage	V	600	1000
Type of current		AC/DC	DC
Fuse		class CC	10x38
Rated frequency	Hz	= / 60	-
Tightening torque	Nm	PZ2 2-2,5	PZ2 2-2,5
Protection degree		IP20	IP20
Terminals' section	mm <sup>2</sup>	25	25
Cross section rigid copper conductors	AWG	16÷10	16÷10
Cross section stranded copper conductors	AWG	16÷3	16÷3
Padlockable (when open)		•	•
Sealable (when closed)		•	•
<b>Marks and Approvals</b>			
cULus		• <sup>(1)</sup>	
UL			• <sup>(2)</sup>

(1) = certified at 600V in compliance with UL 4248-1 and UL 4248-4

(2) = certified at 1000V in compliance with UL 4248-18

## Shock and vibration

### Vibration withstand on the 3 main axis:

- Sinusoidal vibration testing according to IEC 60068-2-6
  - 2 to 13Hz x= 1 mm peak
  - 13 to 100Hz y= 0.7g peak
- Random vibration testing according to IEC 61373
  - Category 1 Class B

### Shock withstand on the 3 main axis:

- Shock testing according to IEC 60068-2-27 15g/11ms/18 shocks
- Shock testing according to IEC 61373 Category 1 Class B

# Order codes

## E 90 series

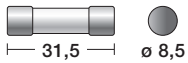
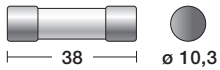
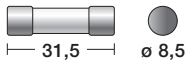
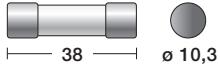

Poles	Rated current	Modu-les	Description Type	ABB code	Bbn 8012542 EAN	Piece weight kg	Pack unit pcs
-------	---------------	----------	------------------	----------	-----------------	-----------------	---------------

### E 90 fuse disconnectors for 10.3 x 38 mm fuses

<b>1</b>	<b>32</b>	<b>1</b>	<b>E 91/32</b>	<b>2CSM200923R1801</b>	<b>009238</b>	<b>0,061</b>	<b>6</b>
1	32	1	E 91/32s*	2CSM202483R1801	024835	0,062	6
1+N	32	2	E 91N/32	2CSM200893R1801	008934	0,130	3
1+N	32	2	E 91N/32s*	2CSM251503R1801	515036	0,131	3
<b>2</b>	<b>32</b>	<b>2</b>	<b>E 92/32</b>	<b>2CSM200883R1801</b>	<b>008835</b>	<b>0,122</b>	<b>3</b>
2	32	2	E 92/32s*	2CSM251493R1801	514930	0,123	3
<b>3</b>	<b>32</b>	<b>3</b>	<b>E 93/32</b>	<b>2CSM204753R1801</b>	<b>047537</b>	<b>0,183</b>	<b>2</b>
3	32	3	E 93/32s*	2CSM202063R1801	020639	0,184	2
3+N	32	4	E 93N/32	2CSM204733R1801	047339	0,252	1
3+N	32	4	E 93N/32s*	2CSM251483R1801	514831	0,254	1
4	32	4	E 94/32	2CSM204723R1801	047230	0,244	1
4	32	4	E 94/32s*	2CSM202053R1801	020530	0,245	1

### E 90 fuse disconnectors for 8.5 x 31.5 mm fuses

<b>1</b>	<b>20</b>	<b>1</b>	<b>E 91/20</b>	<b>2CSM200983R1801</b>	<b>009832</b>	<b>0,061</b>	<b>6</b>
1	20	1	E 91/20s*	2CSM202423R1801	024231	0,062	6
2	20	2	E 92/20	2CSM200953R1801	009535	0,122	3
2	20	2	E 92/20s*	2CSM289623R1801	896234	0,123	3
3	20	3	E 93/20	2CSM200943R1801	009436	0,183	2
3	20	3	E 93/20s*	2CSM289613R1801	896135	0,184	2

The most widely used codes are in green

\*s: versione with blown fuse indicator

Poles	Rated current	Modu-les	Description Type	ABB code	Bbn 8012542 EAN	Piece weight kg	Pack unit pcs
-------	---------------	----------	------------------	----------	-----------------	-----------------	---------------

### E 90h fuseholders for 10.3 x 38 mm fuses

<b>1+N</b>	<b>32</b>	<b>1</b>	<b>E 91hN/32</b>	<b>2CSM200913R1801</b>	<b>009139</b>	<b>0,070</b>	<b>6</b>
1+N	32	1	E 91hN/32s*	2CSM206573R1801	065739	0,071	6
3+N	32	3	E 93hN/32	2CSM204743R1801	047438	0,192	2
3+N	32	3	E 93hN/32s*	2CSM274343R1801	743439	0,193	2

### E 90h fuseholders for 8.5 x 31.5 mm fuses

<b>1+N</b>	<b>20</b>	<b>1</b>	<b>E 91hN/20</b>	<b>2CSM200963R1801</b>	<b>009634</b>	<b>0,070</b>	<b>6</b>
1+N	20	1	E 91hN/20s*	2CSM200703R1801	007036	0,071	6
3+N	20	3	E 93hN/20	2CSM200933R1801	009337	0,192	2
3+N	20	3	E 93hN/20s	2CSM289603R1801	896036	0,193	2

The most widely used codes are in green

\*s: versione with blown fuse indicator

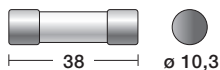

Poles	Rated current	Modules	Description Type	ABB code	Bbn 8012542 EAN	Piece weight kg	Pack unit pcs
<b>E 90 PV fuse disconnectors for 10.3 x 38 mm fuses (DC-20B)</b>							
1	32	1	E 91/32 PV	2CSM204713R1801	047131	0,061	6
1	32	1	E 91/32 PVs*	2CSM204693R1801	046936	0,062	6
<b>2</b>	<b>32</b>	<b>2</b>	<b>E 92/32 PV</b>	<b>2CSM204703R1801</b>	<b>047032</b>	<b>0,122</b>	<b>3</b>
2	32	2	E 92/32 PVs*	2CSM256913R1801	569138	0,122	3

The most widely used codes are in green

\*s: version with blown fuse indicator

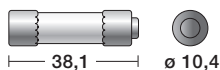

Poles	Rated current	Modules	Description Type	ABB code	Bbn 8012542 EAN	Piece weight kg	Pack unit pcs
<b>E 90 CC fuseholders for Class CC 10.4 x 38.1 mm fuses</b>							
1	30	1	E 91/30 CC	2CSM299872R1801	998723	0,061	6
1	30	1	E 91/30 CCs*	2CSM299882R1801	998822	0,062	6
1+N	30	2	E 91N/30 CC	2CSM299892R1801	998921	0,13	3
1+N	30	2	E 91N/30 CCs*	2CSM299902R1801	999027	0,131	3
2	30	2	E 92/30 CC	2CSM299912R1801	999126	0,122	3
2	30	2	E 92/30 CCs*	2CSM299922R1801	999225	0,123	3
<b>3</b>	<b>30</b>	<b>3</b>	<b>E 93/30 CC</b>	<b>2CSM299932R1801</b>	<b>999324</b>	<b>0,183</b>	<b>2</b>
3	30	3	E 93/30 CCs*	2CSM299942R1801	999423	0,184	2
3+N	30	4	E 93N/30 CC	2CSM299952R1801	999522	0,252	1
3+N	30	4	E 93N/30 CCs*	2CSM299962R1801	999621	0,253	1
4	30	4	E 94/30 CC	2CSM299972R1801	999720	0,244	1
4	30	4	E 94/30 CCs*	2CSM299982R1801	999829	0,245	1

The most widely used codes are in green

\*s: version with blown fuse indication indicator

# Order codes

## E 930 series

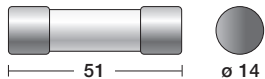

Poles	Rated current	Modules	Description Type	ABB code	Bbn 8012542 EAN	Piece weight kg	Pack unit pcs
<b>E 930 fuse disconnectors for 14 x 51 mm fuses (AC-20B)</b>							
1	50	1,5	E 931/50	2CSM361610R1801	446804	0,200	6
1+N	50	3	E 931N/50	2CSM365610R1801	446903	0,400	3
2	50	3	E 932/50	2CSM362610R1801	447009	0,400	3
<b>3</b>	<b>50</b>	<b>4,5</b>	<b>E 933/50</b>	<b>2CSM363610R1801</b>	<b>447108</b>	<b>0,600</b>	<b>1</b>
3+N	50	6	E 933N/50	2CSM367610R1801	447207	0,800	1

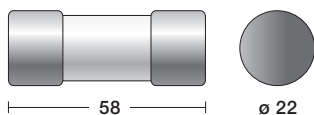

Poles	Rated current	Modules	Description Type	ABB code	Bbn 8012542 EAN	Piece weight kg	Pack unit pcs
<b>E 930 fuse disconnectors for 22 x 58 mm fuses (AC-20B)</b>							
1	125	2	E 931/125	2CSM371710R1801	447504	0,200	6
1+N	125	4	E 931N/125	2CSM375710R1801	447603	0,400	3
2	125	4	E 932/125	2CSM372710R1801	447702	0,400	3
3	125	6	E 933/125	2CSM373710R1801	447801	0,600	1
<b>3+N</b>	<b>125</b>	<b>8</b>	<b>E 933N/125</b>	<b>2CSM377710R1801</b>	<b>447900</b>	<b>0,800</b>	<b>1</b>

The most widely used codes are in green

Poles	Rated current	Modules	Description Type	ABB code	Bbn 8012542 EAN	Piece weight kg	Pack unit pcs
<b>Accessories for E 930 series fuseholders</b>							
<b>Microswitch for fuse blown signalling</b>							
<b>1</b>	<b>50</b>	<b>1,5</b>	<b>E 930/MCR1P50</b>	<b>2CSM060019R1801</b>	<b>451006</b>	<b>0,030</b>	<b>1</b>
3	50	4,5	E 930/MCR3P50	2CSM060029R1801	451105	0,030	1
1	125	2	E 930/MCR1P125	2CSM070019R1801	451204	0,030	1
3	125	6	E 930/MCR3P125	2CSM070029R1801	451303	0,030	1

The most widely used codes are in green



# Wiring diagrams and overall dimensions E 90 series

## E 90 wiring diagrams

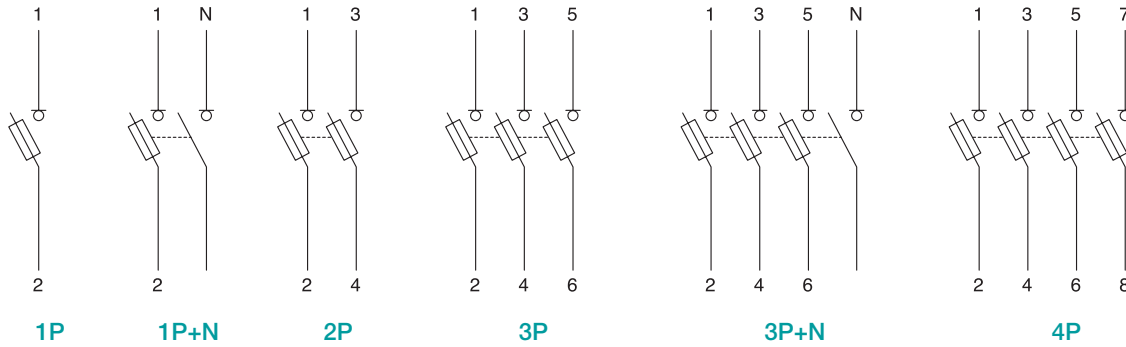

## E 90h wiring diagrams

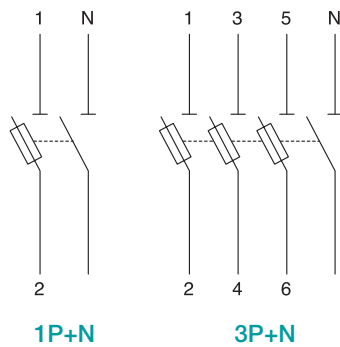

## E 90 PV wiring diagrams

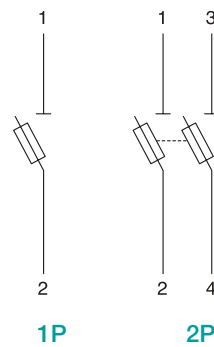

## Overall dimensions

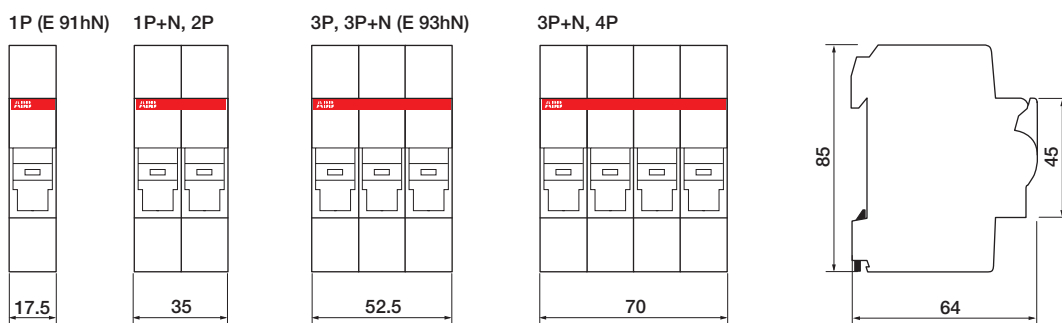

# Wiring diagrams and overall dimensions E 930 series

## Wiring diagrams

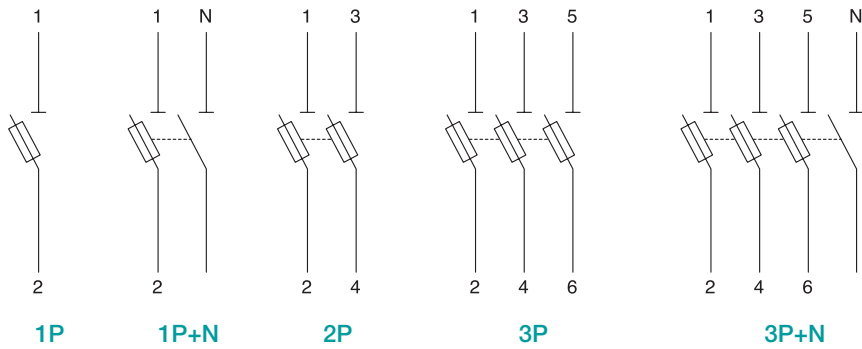

## Overall dimensions:

50 A

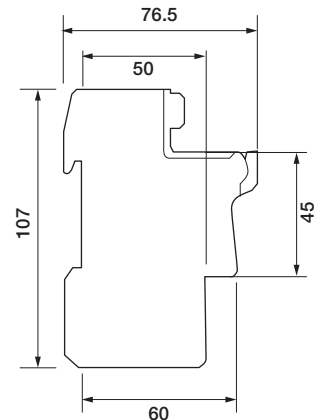
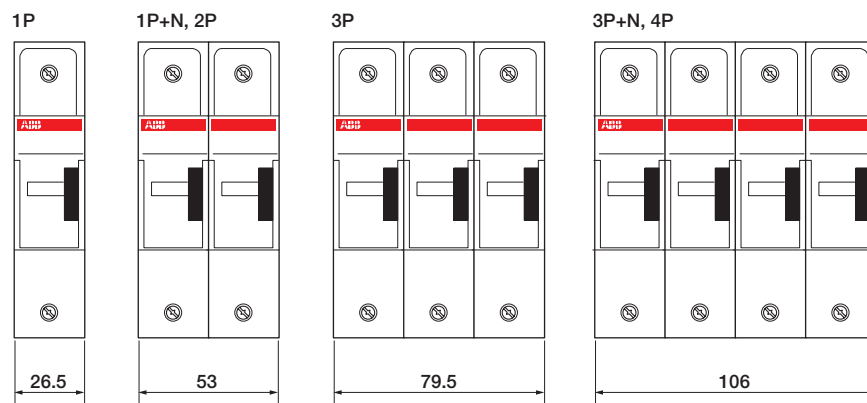

125 A

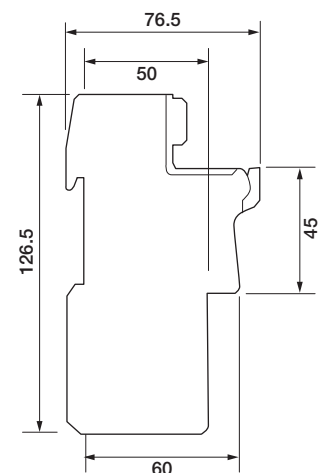
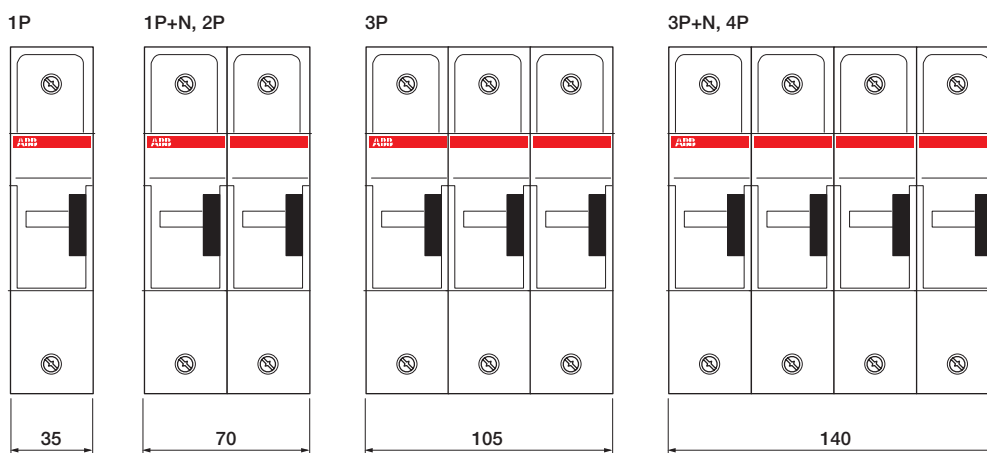



# How to choose the protection system

## Maximum rated current value of the fuse

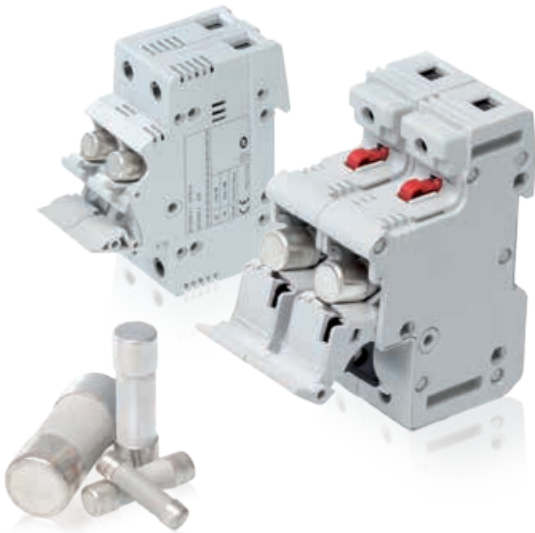

The maximum rated current values of the fuse that can be installed in the fuseholder are given in the table below. These values depend on the rated voltage of the network and conform to the maximum limits of the power dissipated by the protection system, formed by the fuse and fuseholder. ABB fuses and fuseholders allow all the requirements established by the standards to be met in full safety. The performance provided by ABB products allows a fuse with a rated current that exceeds the limit dictated by standard IEC 60269-2-1 (Art. 5-3-1) to be installed in certain situations.

		Fuseholders			
Rated voltage	Fuse curve	E 90/20 8,5 x 31,5 mm	E 90/32 10,3 x 38 mm	E 930/50 14 x 51 mm	E 930/125 22 x 58 mm
400 V c.a.	gG	20 A	32 A	50 A	<b>100 A</b>
	aM	10 A	32 A	50 A	<b>125 A*</b>
500 V c.a.	gG	-	25 A	40 A	100 A
	aM	-	<b>25 A</b>	40 A	100 A
690 V c.a.	gG	-	10 A	25 A	<b>80 A</b>
	aM	-	-	25 A	<b>80 A</b>

\* = to be used in combination with a device which guarantees protection against overload.

## Derating values for E 90 fuseholders

Depending on the rated current, the number of poles installed side by side or the temperature and relative humidity, the derating parameters in the table must be considered if several poles are installed side by side or if the equipment is installed in unusual climatic conditions.

Installation of single poles side by side					
E 91/32		E 91hN/32		E930 50/125	
Poles	Maximum current	Poles	Maximum current	Poles	Maximum current
1...4	In	1...3	In	1...3	In
5...7	0,8 x In	4...9	0,7 x In	4...6	0,95 x In
more than 7	0,7 x In	more than 10	0,6 x In	more than 7	0,9 x In

Climatic conditions				
Maximum temperature	20 °C	30 °C	40 °C	50 °C
Maximum humidity	95 %	90 %	80 %	50 %
Maximum current	In	In x 0,95	In x 0,9	In x 0,8

# E 9F gG cylindrical fuses

## The fastest protection for industrial automation switchboards

E 9F gG series fuses are the best way to protect against overloads and short-circuits together with series fuse E 90 and E 930. They feature a fast tripping curve that is ideal for protecting electronic devices, transformers and electric cables. The E 9F gG series is available for all the main sizes (8.5 x 31.5 mm, 10.3 x 38 mm, 14 x 51 mm e 22 x 58 mm) and with a wide range of rated current values (from 1 A to 125 A and up to 690 V a.c.). All the E 9F series fuses conform to the RoHS directive and are type-approved in accordance with the most important international naval marks.

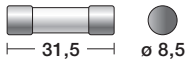

E 9F 8 gG 8.5 x 31.5 mm cylindrical fuses

Rated current In [A]	Description Type	ABB code	Bbn 8012542 EAN	Piece weight kg	Package
1	E 9F8 GG1	2CSM257573R1801	575733	0,004	10
2	E 9F8 GG2	2CSM256393R1801	563938	0,004	10
4	E 9F8 GG4	2CSM258663R1801	586630	0,004	10
6	E 9F8 GG6	2CSM257483R1801	574835	0,004	10
8	E 9F8 GG8	2CSM256303R1801	563037	0,004	10
10	E 9F8 GG10	2CSM277573R1801	775737	0,004	10
12	E 9F8 GG12	2CSM277353R1801	773535	0,004	10
16	E 9F8 GG16	2CSM277133R1801	771333	0,004	10
20	E 9F8 GG20	2CSM277503R1801	775034	0,004	10

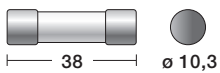

E 9F 10 gG 10.3 x 38 mm cylindrical fuses

Rated current In [A]	Description Type	ABB code	Bbn 8012542 EAN	Piece weight kg	Package
0,5	E 9F10 GG05	2CSM277333R1801	773337	0,007	10
1	E 9F10 GG1	2CSM277113R1801	771135	0,007	10
2	E 9F10 GG2	2CSM258723R1801	587231	0,007	10
4	E 9F10 GG4	2CSM257543R1801	575436	0,007	10
6	E 9F10 GG6	2CSM256363R1801	563631	0,007	10
8	E 9F10 GG8	2CSM258633R1801	586333	0,007	10
10	E 9F10 GG10	2CSM257453R1801	574538	0,007	10
12	E 9F10 GG12	2CSM256273R1801	562733	0,007	10
16	E 9F10 GG16	2CSM277543R1801	775430	0,007	10
20	E 9F10 GG20	2CSM277323R1801	773238	0,007	10
25	E 9F10 GG25	2CSM277103R1801	771036	0,007	10
32	E 9F10 GG32	2CSM258713R1801	587132	0,007	10

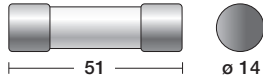

#### E 9F 14 gG 14 x 51 mm cylindrical fuses

Rated current In [A]	Description Type	ABB code	Bbn 8012542 EAN	Piece weight kg	Package
2	E 9F14 GG2	2CSM277523R1801	775232	0,018	10
4	E 9F14 GG4	2CSM277303R1801	773030	0,018	10
6	E 9F14 GG6	2CSM277083R1801	770831	0,018	10
8	E 9F14 GG8	2CSM291003R1801	910039	0,018	10
10	E 9F14 GG10	2CSM290983R1801	909835	0,018	10
12	E 9F14 GG12	2CSM290963R1801	909637	0,018	10
16	E 9F14 GG16	2CSM258783R1801	587835	0,018	10
20	E 9F14 GG20	2CSM257603R1801	576037	0,018	10
25	E 9F14 GG25	2CSM256423R1801	564232	0,018	10
32	E 9F14 GG32	2CSM258693R1801	586937	0,018	10
40	E 9F14 GG40	2CSM257513R1801	575139	0,018	10
50	E 9F14 GG50	2CSM256333R1801	563334	0,018	10

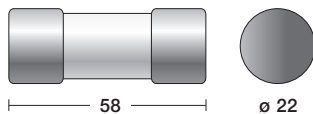

#### E 9F 22 gG 22 x 58 mm cylindrical fuses

Rated current In [A]	Description Type	ABB code	Bbn 8012542 EAN	Piece weight kg	Package
4	E 9F22 GG4	2CSM257183R1801	571834	0,048	10
6	E 9F22 GG6	2CSM259283R1801	592839	0,048	10
8	E 9F22 GG8	2CSM258103R1801	581031	0,048	10
10	E 9F22 GG10	2CSM256923R1801	569237	0,048	10
12	E 9F22 GG12	2CSM259403R1801	594031	0,048	10
16	E 9F22 GG16	2CSM258223R1801	582236	0,048	10
20	E 9F22 GG20	2CSM257043R1801	570431	0,048	10
25	E 9F22 GG25	2CSM259533R1801	595335	0,048	10
32	E 9F22 GG32	2CSM258353R1801	583530	0,048	10
40	E 9F22 GG40	2CSM257173R1801	571735	0,048	10
50	E 9F22 GG50	2CSM259393R1801	593935	0,048	10
63	E 9F22 GG63	2CSM258213R1801	582137	0,048	10
80	E 9F22 GG80	2CSM257033R1801	570332	0,048	10
100	E 9F22 GG100	2CSM259523R1801	595236	0,048	10
125	E 9F22 GG125	2CSM258343R1801	583431	0,048	10

#### Technical specifications

Rated voltage	[V]	400, 500, 690 AC
Rated current	[A]	0,5...125
Breaking capacity	[kA]	20, 80, 120
Overall dimensions	[mm]	8,5 x 31,5, 10,3 x 38, 14 x 51, 22 x 58
Weight	[g]	4, 7, 18, 48
Marks		LLOYD, BV
Standards		IEC 60269-2; ROHS 2002/98/CE

# E 9F gG cylindrical fuses

## The fastest protection for industrial automation switchboards

E 9F 8 gG 8.5 x 31.5 mm cylindrical fuses

Type	Rated current [A]	Rated voltage [V a.c.]	Breaking capacity [kA]
E 9F8 GG1	1	400	20
E 9F8 GG2	2	400	20
E 9F8 GG4	4	400	20
E 9F8 GG6	6	400	20
E 9F8 GG8	8	400	20
E 9F8 GG10	10	400	20
E 9F8 GG12	12	400	20
E 9F8 GG16	16	400	20
E 9F8 GG20	20	400	20

E 9F 14 gG 14 x 51 mm cylindrical fuses

Type	Rated current [A]	Rated voltage [V a.c.]	Breaking capacity [kA]
E 9F10 GG05	0,5	500	120
E 9F10 GG1	1	500	120
E 9F10 GG2	2	500	120
E 9F10 GG4	4	500	120
E 9F10 GG6	6	500	120
E 9F10 GG8	8	500	120
E 9F10 GG10	10	500	120
E 9F10 GG12	12	500	120
E 9F10 GG16	16	500	120
E 9F10 GG20	20	500	120
E 9F10 GG25	25	500	120
E 9F10 GG32	32	400	120

E 9F 10 gG 10.3 x 38 mm cylindrical fuses

Type	Rated current [A]	Rated voltage [V a.c.]	Breaking capacity [kA]
E 9F14 GG2	2	690	80
E 9F14 GG4	4	690	80
E 9F14 GG6	6	690	80
E 9F14 GG8	8	690	80
E 9F14 GG10	10	690	80
E 9F14 GG12	12	690	80
E 9F14 GG16	16	690	80
E 9F14 GG20	20	690	80
E 9F14 GG25	25	690	80
E 9F14 GG32	32	500	120
E 9F14 GG40	40	500	120
E 9F14 GG50	50	400	120

E 9F 22 gG 22 x 58 mm cylindrical fuses

Type	Rated current [A]	Rated voltage [V a.c.]	Breaking capacity [kA]
E 9F22 GG4	4	690	80
E 9F22 GG6	6	690	80
E 9F22 GG8	8	690	80
E 9F22 GG10	10	690	80
E 9F22 GG12	12	690	80
E 9F22 GG16	16	690	80
E 9F22 GG20	20	690	80
E 9F22 GG25	25	690	80
E 9F22 GG32	32	690	80
E 9F22 GG40	40	690	80
E 9F22 GG50	50	690	80
E 9F22 GG63	63	690	80
E 9F22 GG80	80	690	80
E 9F22 GG100	100	500	120
E 9F22 GG125	125	400	120

Power dissipation [W]				
In [A]	Size mm			
	8,5 x 31,5	10,3 x 38	14 x 51	22 x 58
0,5	0,55	2		
1	0,35	2,5	3,4	
2	0,45	0,70	1	1,20
4	0,06	0,80	1,10	1,30
6	0,83	0,90	1,20	1,40
8	1	1,10	1,50	1,65
10	1,2	1,35	1,80	2
12	1,3	1,55	2,10	2,40
16	1,7	1,90	2,55	3
20	2	2,30	3	3,40
25	2,4	2,80	3,50	3,80
32		3	3,80	4,30
40			4,40	5,10
50			4,70	5,50
63				6,70
80				8
100				9
125				12,5

It is important to make sure that the power dissipated by the fuse does not exceed the limit imposed by the fuseholder in which it is installed. The maximum power dissipation values, in accordance with the specifications of the E 90 and E 930 series fuseholders, are highlighted in green.

# E 9F gG cylindrical fuses

## The fastest protection for industrial automation switchboards

Characteristic  $tI$

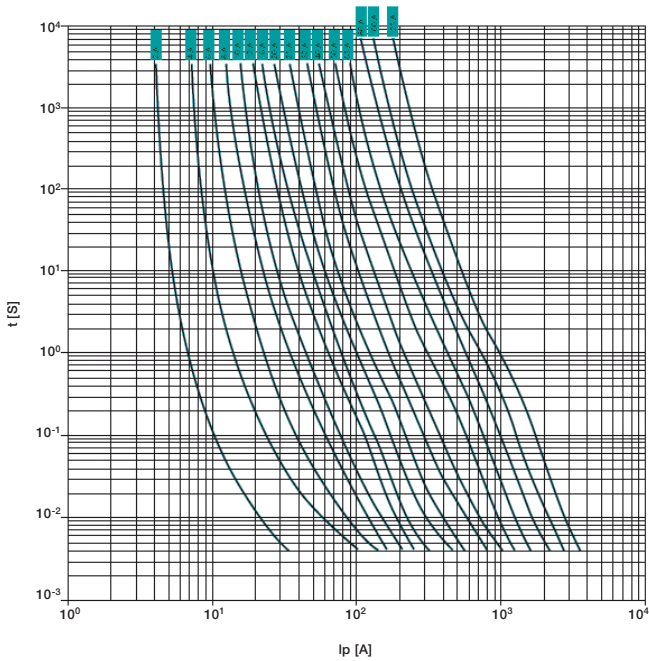

Characteristic  $I^2t$

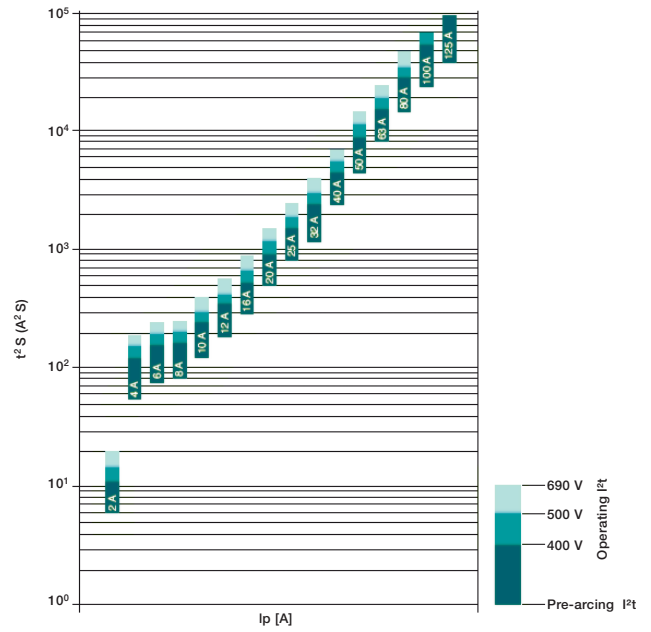

Temperature increase

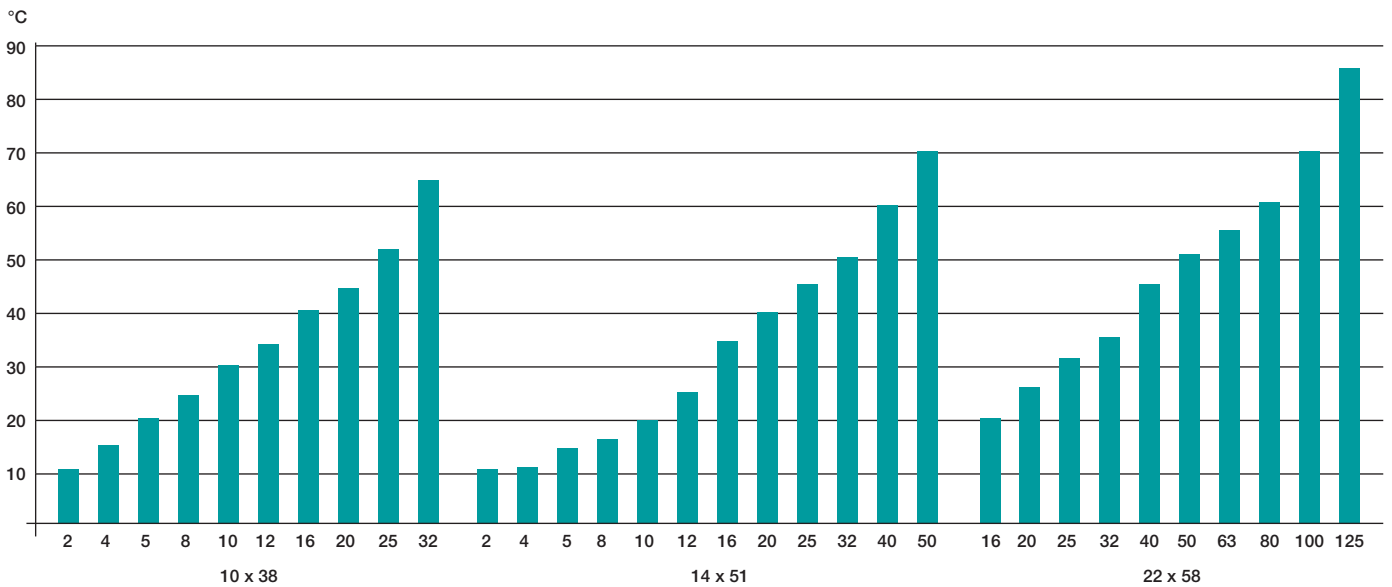

Maximum length [m] of the copper conductors										
Copper conductor section (mm <sup>2</sup> )	Rated current In (A) of gG fuses									
	16	20	25	32	40	50	63	80	100	125
1,5	99/113	86/87	40/59	21/29	13/16	7/9				
2,5		134	110/122	67/84	41/51	25/33	13/20	8/11		
4			183	139	108/119	67/84	46/58	24/32	14/17	7,3/10
6				214	165	139	94/113	55/70	33/41	20/27
10					275	226	172	130	90/108	57/70
16							283	217	168	128
25								336	257	197
35									367	283
50										379

Use this table to find the cable length, in meters, that is protected by a fuse.

Just cross the rated current of the fuse (in the columns) with the section of the conductor (on the lines). The resulting number corresponds to the protected length of the conductor: for example, a 32 A fuse can protect up to 214 meters of 6 mm<sup>2</sup> section cable. When there are two values, it means that the maximum length of the cable is between the two numbers given in the table.

# E 9F aM cylindrical fuses

## Delayed protection for motor starts

E 9F aM series fuses are the best way to protect against overloads and short-circuits together with series fuse E 90 and E 930. They feature a delayed tripping curve and are therefore ideal for protecting industrial motors that require high inrush current during the starting phase. The E 9F aM series is available for all the main sizes (8.5 x 31.5 mm, 10.3 x 38 mm, 14 x 51 mm e 22 x 58 mm) and with a wide range of rated current values (from 1 A to 125 A and up to 690 V a.c.). All the E 9F series fuses conform to the RoHS directive and are type-approved in accordance with the most important international naval marks.

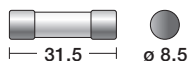

E 9F 8 aM 8.5 x 31.5 mm cylindrical fuses

Rated current In [A]	Description Type	ABB code	Bbn 8012542 EAN	Piece weight kg	Package
1	E 9F8 AM1	2CSM277283R1801	772835	0,004	10
2	E 9F8 AM2	2CSM277063R1801	770633	0,004	10
4	E 9F8 AM4	2CSM258743R1801	587439	0,004	10
6	E 9F8 AM6	2CSM257563R1801	575634	0,004	10
8	E 9F8 AM8	2CSM256383R1801	563839	0,004	10
10	E 9F8 AM10	2CSM258653R1801	586531	0,004	10

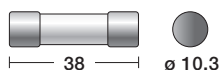

E 9F 10 aM 10.3 x 38 mm cylindrical fuses

Rated current In [A]	Description Type	ABB code	Bbn 8012542 EAN	Piece weight kg	Package
0,5	E 9F10 AM05	2CSM257473R1801	574736	0,007	10
1	E 9F10 AM1	2CSM256293R1801	562931	0,007	10
2	E 9F10 AM2	2CSM277563R1801	775638	0,007	10
4	E 9F10 AM4	2CSM277343R1801	773436	0,007	10
6	E 9F10 AM6	2CSM277123R1801	771234	0,007	10
8	E 9F10 AM8	2CSM258733R1801	587330	0,007	10
10	E 9F10 AM10	2CSM257553R1801	575535	0,007	10
12	E 9F10 AM12	2CSM256373R1801	563730	0,007	10
16	E 9F10 AM16	2CSM258643R1801	586432	0,007	10
20	E 9F10 AM20	2CSM257463R1801	574637	0,007	10
25	E 9F10 AM25	2CSM256283R1801	562832	0,007	10
32	E 9F10 AM32	2CSM277553R1801	775539	0,007	10



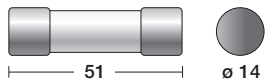

#### E 9F 14 aM 14 x 51 mm cylindrical fuses

Rated current In [A]	Description Type	ABB code	Bbn 8012542 EAN	Piece weight kg	Package
1	E 9F14 AM1	2CSM257533R1801	575337	0,018	10
2	E 9F14 AM2	2CSM256353R1801	563532	0,018	10
4	E 9F14 AM4	2CSM258623R1801	586234	0,018	10
6	E 9F14 AM6	2CSM257443R1801	574439	0,018	10
8	E 9F14 AM8	2CSM256263R1801	562634	0,018	10
10	E 9F14 AM10	2CSM277533R1801	775331	0,018	10
12	E 9F14 AM12	2CSM277313R1801	773139	0,018	10
16	E 9F14 AM16	2CSM277093R1801	770930	0,018	10
20	E 9F14 AM20	2CSM258703R1801	587033	0,018	10
25	E 9F14 AM25	2CSM257523R1801	575238	0,018	10
32	E 9F14 AM32	2CSM256343R1801	563433	0,018	10
40	E 9F14 AM40	2CSM258613R1801	586135	0,018	10
45	E 9F14 AM45	2CSM257433R1801	574330	0,018	10
50	E 9F14 AM50	2CSM256253R1801	562535	0,018	10

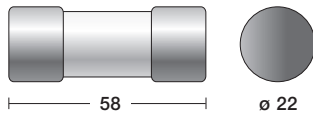

#### E 9F 22 aM 22 x 58 mm cylindrical fuses

Rated current In [A]	Description Type	ABB code	Bbn 8012542 EAN	Piece weight kg	Package
6	E 9F22 AM6	2CSM258603R1801	586036	0,048	10
8	E 9F22 AM8	2CSM257423R1801	574231	0,048	10
10	E 9F22 AM10	2CSM256243R1801	562436	0,048	10
12	E 9F22 AM12	2CSM277513R1801	775133	0,048	10
16	E 9F22 AM16	2CSM277293R1801	772934	0,048	10
20	E 9F22 AM20	2CSM277073R1801	770732	0,048	10
25	E 9F22 AM25	2CSM277493R1801	774938	0,048	10
32	E 9F22 AM32	2CSM277273R1801	772736	0,048	10
40	E 9F22 AM40	2CSM277053R1801	770534	0,048	10
50	E 9F22 AM50	2CSM259413R1801	594130	0,048	10
63	E 9F22 AM63	2CSM258233R1801	582335	0,048	10
80	E 9F22 AM80	2CSM257053R1801	570530	0,048	10
100	E 9F22 AM100	2CSM259543R1801	595434	0,048	10
125	E 9F22 AM125	2CSM258363R1801	583639	0,048	10

#### Technical specifications

Rated voltage	[V]	400, 500, 690 AC
Rated current	[A]	0,5...125
Breaking capacity	[kA]	20, 80, 120
Overall dimensions	[mm]	8,5 x 31,5, 10,3 x 38, 14 x 51, 22 x 58
Weight	[g]	4, 7, 18, 48
Marks		LLOYD, BV
Standards		IEC 60269-2; ROHS 2002/98/CE

# E 9F aM cylindrical fuses

## Delayed protection for motor starts

E 9F 8 aM 8.5 x 31.5 mm cylindrical fuses			
Type	Rated current [A]	Rated voltage [V a.c.]	Breaking capacity [kA]
E 9F1 AM1	1	400	20
E 9F8 AM2	2	400	20
E 9F8 AM4	4	400	20
E 9F8 AM6	6	400	20
E 9F8 AM8	8	400	20
E 9F8 AM10	10	400	20

E 9F 10 aM 10.3 x 38 mm cylindrical fuses			
Type	Rated current [A]	Rated voltage [V a.c.]	Breaking capacity [kA]
E 9F10 AM05	0,5	500	120
E 9F10 AM1	1	500	120
E 9F10 AM2	2	500	120
E 9F10 AM4	4	500	120
E 9F10 AM6	6	500	120
E 9F10 AM8	8	500	120
E 9F10 AM10	10	500	120
E 9F10 AM12	12	500	120
E 9F10 AM16	16	500	120
E 9F10 AM20	20	500	120
E 9F10 AM25	25	400	120
E 9F10 AM32	32	400	120

E 9F 14 aM 14 x 51 mm cylindrical fuses			
Type	Rated current [A]	Rated voltage [V a.c.]	Breaking capacity [kA]
E 9F14 AM1	1	690	80
E 9F14 AM2	2	690	80
E 9F14 AM4	4	690	80
E 9F14 AM6	6	690	80
E 9F14 AM8	8	690	80
E 9F14 AM10	10	690	80
E 9F14 AM12	12	690	80
E 9F14 AM16	16	690	80
E 9F14 AM20	20	690	80
E 9F14 AM25	25	690	80
E 9F14 AM32	32	500	120
E 9F14 AM40	40	500	120
E 9F14 AM50	50	400	120

E 9F 22 aM 22 x 58 mm cylindrical fuses			
Type	Rated current [A]	Rated voltage [V a.c.]	Breaking capacity [kA]
E 9F22 AM6	6	690	80
E 9F22 AM8	8	690	80
E 9F22 AM10	10	690	80
E 9F22 AM12	12	690	80
E 9F22 AM16	16	690	80
E 9F22 AM20	20	690	80
E 9F22 AM25	25	690	80
E 9F22 AM32	32	690	80
E 9F22 AM40	40	690	80
E 9F22 AM50	50	690	80
E 9F22 AM63	63	690	80
E 9F22 AM80	80	690	80
E 9F22 AM100	100	500	120
E 9F22 AM125	125	400	120

# E 9F aM cylindrical fuses

## Delayed protection for motor starts

It is important to make sure that the power dissipated by the fuse does not exceed the limit imposed by the fuseholder in which it is installed. The maximum power dissipation values, in accordance with the specifications of the E 90 and E 930 series fuseholders, are highlighted in green.

In [A]	Power dissipation [W]			
	Size mm			
	8,5 x 31,5	10,3 x 38	14 x 51	22 x 58
0,5		0,50	0,75	
1	0,09	0,13	0,18	0,20
2	0,15	0,20	0,25	0,30
4	0,26	0,30	0,40	0,50
6	0,35	0,45	0,55	0,65
8	0,47	0,55	0,65	0,75
10	0,55	0,65	0,75	0,85
12	0,7	0,75	0,85	1
16		0,90	1,20	1,40
20		1,10	1,50	1,70
25		1,40	1,80	2
32		2	2,10	2,60
40			2,60	3,20
45			2,80	
50			2,90	3,90
63				4,60
80				5,60
100				6,50
125				9,50

# E 9F aM cylindrical fuses

## Delayed protection for motor starts

Characteristic  $tI$

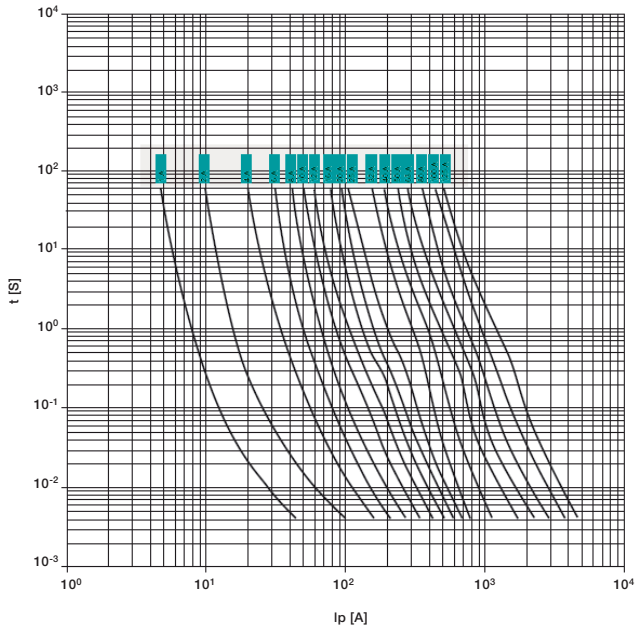

Characteristic  $I^2t$

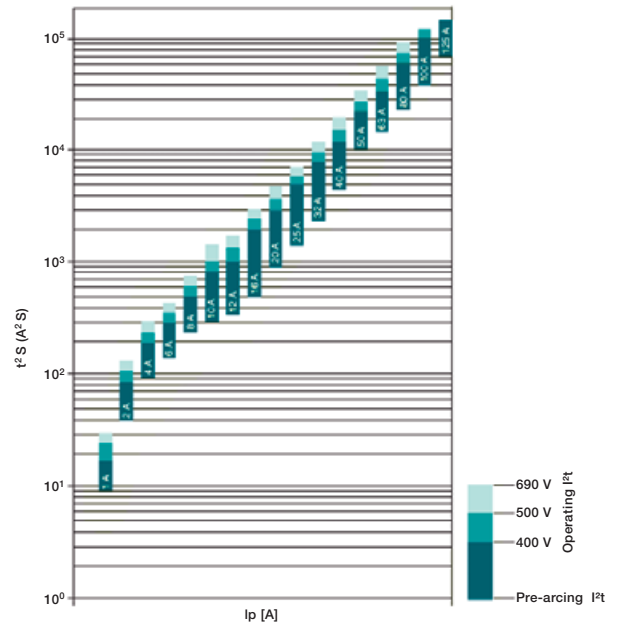

Temperature increase

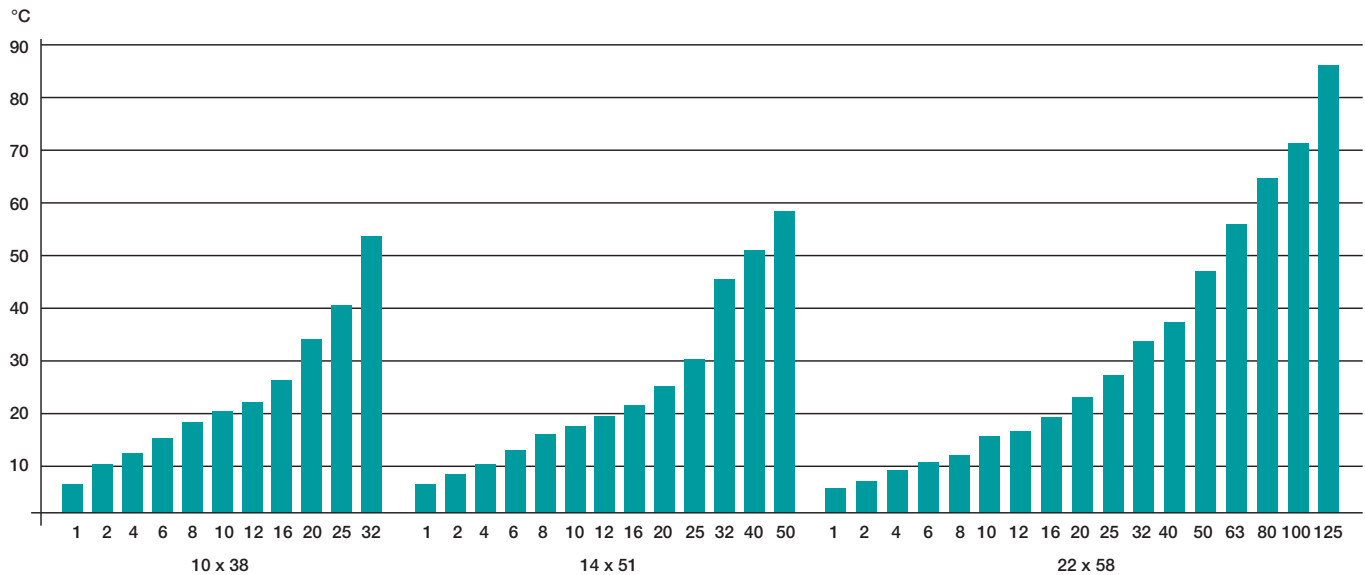

Maximum cable length according to the rated current and section of the conductor

Copper conductor section (mm <sup>2</sup> )	Rated current In (A) of aM fuses									
	16	20	25	32	40	50	63	80	100	125
1,5	55/64	37-45	25/30	15/20						
2,5	116	84/94	58/68	40/49	26/32	17/20				
4	181	147	118	84/95	58/68	42/48	28/33	18/23		
6	273	223	178	139	105/117	79/89	55/64	37/42	26/31	14/20
10				227	181	147	113/125	80/94	57/69	40/47
16						236	189	151	120	83/97
25								231	185	147
35									262	210

Use this table to find the cable length, in meters, that is protected by a fuse.

Just cross the rated current of the fuse (in the columns) with the section of the conductor (on the lines). The resulting number corresponds to the protected length of the conductor: for example, a 32 A fuse can protect up to 214 meters of 6 mm<sup>2</sup> section cable. When there are two values, it means that the maximum length of the cable is between the two numbers given in the table.

# E 9F gPV cylindrical fuses

## The best protection for direct current photovoltaic installations

The E 9F PV series of cylindrical fuses has been specifically designed for protecting direct current circuits up to 1000 V. Available in the 10.3 x 38 mm size for up to 30 A rated current values, they are the best way to protect the strings, inverters and surge arresters in photovoltaic installations according to IEC 60269-6 "Supplementary requirements for fuse-links for the protection of solar photovoltaic energy systems".

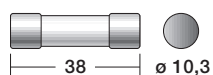

E 9F gPV 10.3 x 38 mm cylindrical fuses

Rated current In [A]	Description Type	ABB code	Bbn 8012542 EAN	Piece weight Kg	Package
1	E 9F1 PV	2CSM213456R1801	134565	0,007	10
2	E 9F2 PV	2CSM213466R1801	134664	0,007	10
3	E 9F3 PV	2CSM213476R1801	134763	0,007	10
4	E 9F4 PV	2CSM213486R1801	134862	0,007	10
5	E 9F5 PV	2CSM213496R1801	134961	0,007	10
6	E 9F6 PV	2CSM213506R1801	135067	0,007	10
7	E 9F7 PV	2CSM213516R1801	135166	0,007	10
8	E 9F8 PV	2CSM213526R1801	135265	0,007	10
10	E 9F10 PV	2CSM213536R1801	135364	0,007	10
12	E 9F12 PV	2CSM213546R1801	135463	0,007	10
15	E 9F15 PV	2CSM213556R1801	135562	0,007	10
20	E 9F20 PV	2CSM213566R1801	135661	0,007	10
25	E 9F25 PV	2CSM213576R1801	135760	0,007	10
30	E 9F30 PV	2CSM213586R1801	135869	0,007	10

### Technical specifications

Rated voltage	[V]	1000 DC
Rated current	[A]	1...30
Breaking capacity	[kA]	10
Minimum breaking capability		da 1A a 7A = 1.3 x In da 8A a 30A = 2.0 x In
Dimensions	[mm]	10,3 x 38
Weight	[g]	7
Standards		IEC 60269-6; ROHS 2002/98/CE

E 9F gPV 10.3 x 38 mm cylindrical fuses

Type	Rated current [A]	Dissipated power 0.7 In [W]	Dissipated power 0.8 In [W]	Dissipated power In [W]	I <sup>2</sup> t PreArc [A <sup>2</sup> s]	Total I <sup>2</sup> t [A <sup>2</sup> s]
E 9F1 PV	1	0,12	0,16	0,32	1,2	19
E 9F2 PV	2	0,15	0,20	0,43	10,4	120
E 9F3 PV	3	0,70	0,90	1,4	3,1	130
E 9F4 PV	4	0,70	0,80	1,3	10,4	220
E 9F5 PV	5	0,70	0,90	1,4	22	330
E 9F6 PV	6	0,70	0,90	1,5	49	410
E 9F7 PV	7	0,80	1	1,5	65	630
E 9F8 PV	8	0,80	1	1,1	6,5	105
E 9F10 PV	10	0,90	1,20	1,5	10	127
E 9F12 PV	12	1	1,3	2	17	215
E 9F15 PV	15	1,20	1,60	3	26	495
E 9F20 PV	20	1,40	1,90	4,4	49	755
E 9F25 PV	25	1,20	1,70	2,90	132	1650
E 9F30 PV	30	1,50	2,10	3,80	197	1850

The power dissipation of the fuse cannot exceed the maximum power dissipation accepted by the fuseholder.

Derating in combination with Ambient Temperature

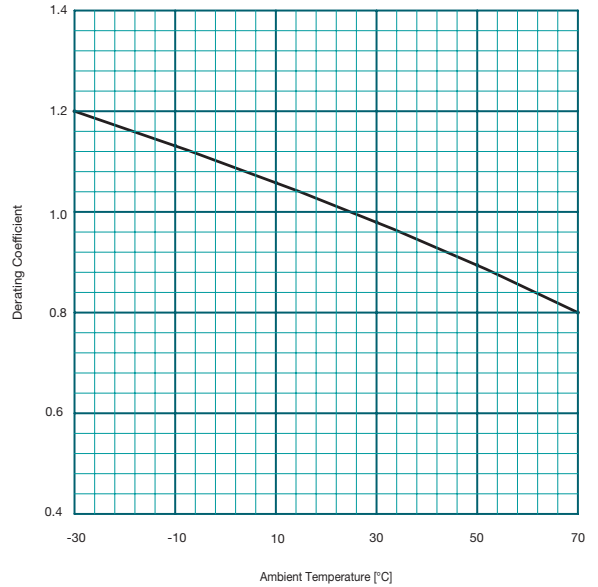

Time/current tripping characteristics

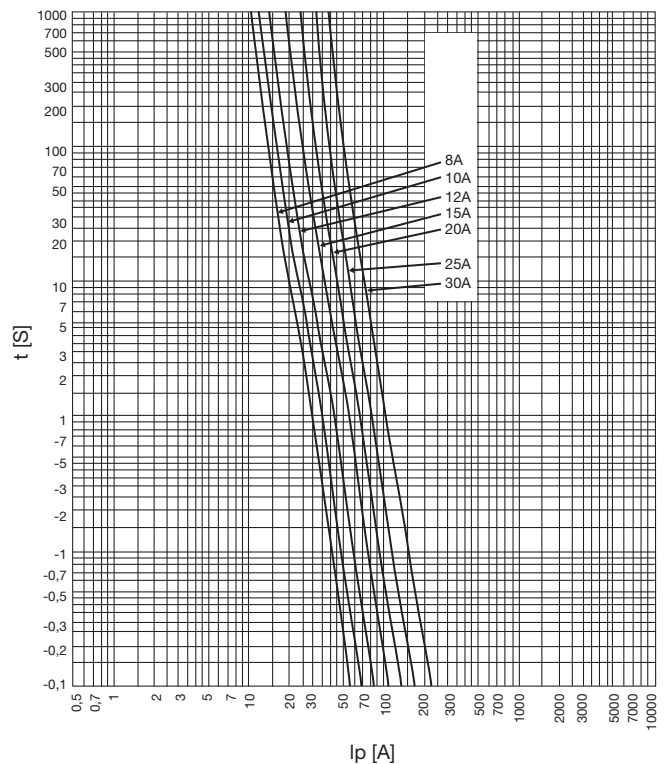
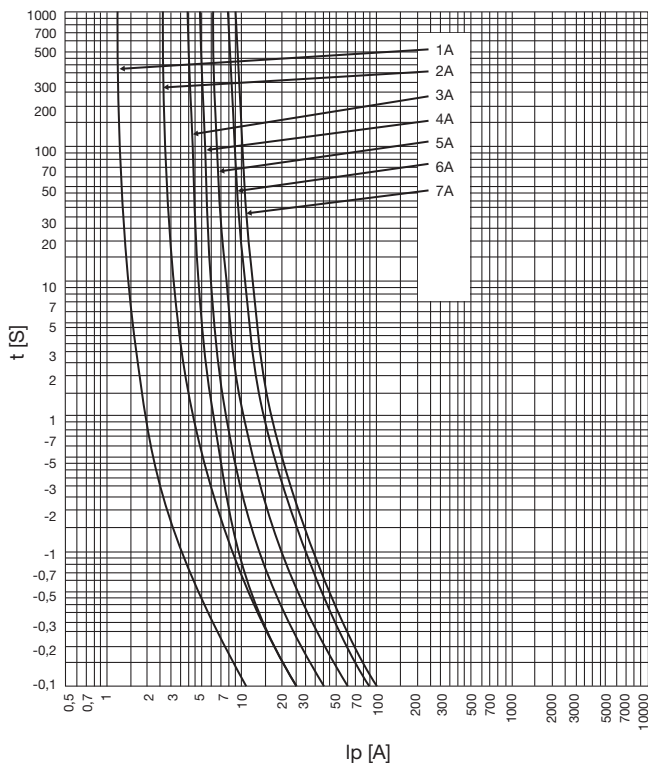

# Questions & answers

## Technical and regulatory details concerning the E 90 range

### IEC 60947-3: switches, disconnectors, switch-disconnectors and fuse-combination units

This standard establishes the requirements of a device to ensure its suitability for disconnection and operation.

#### Disconnector:

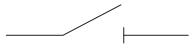

A disconnector is a mechanical control device which, when open, meets the prescriptions for the disconnection function laid down by the international IEC 60947-3 standard. Opening a disconnector ensures that downstream the circuit is electrically isolated from upstream. This condition is necessary if you need to operate on a network component, e.g. during maintenance. Pursuant to the IEC 60364 standard, any maintenance operations on the installation are prohibited unless circuits have been previously disconnected.

#### Fuse-disconnector:

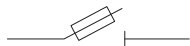

This defines a fuseholder that also performs disconnecting functions. Not all fuseholders are also disconnectors: to meet this definition they must meet the requirements and pass the tests provided for in the IEC 60947-3 standard.

#### Fuse-switch-disconnector:

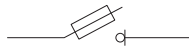

According to the IEC 60947-3 standard, this definition concerns a fuse-switch-disconnector that enables switching under load. Not all fuse-disconnectors enable this operation: to be considered as a fuse-switch-disconnector a device must have utilization category equal to AC-21B or above.

#### Utilization categories:

Not all devices intended for disconnection have the same performance. The type of operation allowed depends on a designation that specifically defines the methods of use, i.e. the utilization category.

This identifies:

- The nature of current (AC/DC)
- The type of switching allowed (no load, resistive loads, highly inductive loads, etc.)
- The operation frequency

E 90 fuse-switch disconnectors have AC-22B utilization category up to 400V and utilization category AC-20B up to 690V. The E 90 PV fuse-switch-disconnectors have DC-20B utilization category.

Current nature	Utilization category		Typical applications
	A	B	
Alternating current	AC-20A	AC-20B	Connecting and disconnecting under no-load conditions
	AC-21A	AC-21B	Switching of resistive loads including moderate overloads
	AC-22A	<b>AC-22B</b>	<b>Switching of mixed resistive and inductive loads, including moderate overload</b>
	AC-23A	AC-23B	Switching of motor loads or other highly inductive loads
Direct current	DC-20A	<b>DC-20B</b>	<b>Connecting and disconnecting under no-load conditions</b>
	DC-21A	DC-21B	Switching of resistive loads including moderate overloads
	DC-22A	DC-22B	Switching of mixed resistive and inductive loads, including moderate overloads (e.g. shunt motors)
	DC-23A	DC-23B	Switching of highly inductive loads? (e.g. series motors)

#### Which loads can be disconnected using a product with AC-22B utilization category?

The AC-22B utilization category allows occasional operation of mixed, resistive and inductive loads with moderate overloads in alternating current circuits. Mixed loads include: transformers, corrected motors, capacitor batteries, discharge lamps, heating, etc.

#### Which loads can be disconnected using a product with AC-20B utilization category?

The AC-20B utilization category does not allow operation under load. Disconnection is possible only by first disconnecting the load through an appropriate switch.





### **IEC 60269-1: Fuses with voltage not exceeding 1000 V in alternating current and 1500 V in direct current**

This standard establishes the requirements of low voltage fuses, and as a result the requirements of fuseholders as devices intended to accommodate fuses.

This standard includes two different sections, with different requirements depending on the type of individual using the equipment:

**IEC 60269-2:** supplementary requirements for fuses for use by skilled persons (mainly for industrial application).

**IEC 60269-3:** supplementary requirements for fuses for use by unskilled persons (mainly for household and similar applications).

### **What is the difference between a IEC 60947-3-compliant fuseholder and a IEC 60947-2-compliant fuseholder?**

These are two complementary standards: IEC 60269-2 establishes the characteristics of fuses, and, from these general requirements for fuseholders are derived. It is the reference standard for overcurrent protection but not for disconnection and switching.

### **Are fuseholders marked UR and UL equivalent to each other?**

They are different products and they comply with equally different requirements. E 90/32 switch disconnectors conform to IEC standards and accommodate midget fuses. However, since they are recognized by the UL laboratories, by means of the UR mark, they can be used as components in UL-certified machines designed for the American market.

On the other hand, E 90/30 CC fuseholders are specifically designed and tested in accordance with the American standards. They are able to accommodate Class CC cylindrical fuses, which possess particular limitation characteristics. This means that it is forbidden to use 10.3x38 fuses that conform to IEC standards in E 90/30 CC fuseholders.



# Questions & answers

## Technical and regulatory details concerning the E 9F range

### Maximum rated current for cylindrical fuses according to IEC 60269-2-1 (Art. 5-3-1).

Size of fuse [mm]	400 V a.c.		500 V a.c.		690 V a.c.	
	gG	aM	gG	aM	gG	aM
$I_n$ A						
8,5 x 31,5	16	10	-	--	-	-
10,3 x 38	-	-	25	16	10	-
14 x 51	-	-	50	40	25	25
22 x 58	-	-	100	100	50	50

The Standard also allows the use of fuses with rated current values that are higher than the value in the table. The maximum rated current values envisaged for the fuseholders are indicated



### Can fuses with rated current values higher than the one indicated in the table be used? For example, can a 10.3 x 38 mm 32 A gG fuse be used in a 10.3 x 38 mm E 90/32 fuseholder?

Yes, in compliance with the instructions provided by the manufacturer: make sure that the power dissipated at the rated voltage value declared by the manufacturer for the size considered does not exceed the maximum dissipated power limit of the fuseholder. In this specific case, an E 9F10 GG32 fuse dissipates 3 W at 400 V rated voltage. Since an E 90/32 series fuseholder for 10.3 x 38 mm fuses achieves 3 W thermal dissipation, the fuse in question can be used at 400 V rated voltage or less.

### Can a 10.3 x 38 mm 32 A gG fuse be used in a 10.3 x 38 mm E 90/32 fuseholder with a rated voltage exceeding 400 V?

In the specific case of E 9F10 GG32, use of rated voltage exceeding 400 V fails to allow the equipment to comply with the maximum dissipated power limit.

### Maximum acceptable values of power dissipation in order to be used in combination with the fuseholders according to IEC 60269-2.

Characteristic curve	Size of fuse			
	8,5 x 31,5	10,3 x 38	14 x 51	22 x 58
gG	2,5 W	3 W	5 W	9,5 W
aM	0,9 W	1,2 W	3 W	7 W
gPV		3 W		

The table gives the maximum dissipated power values of the fuses, considering their size and characteristic curve. The values shown correspond to the maximum dissipated power limit for the fuseholders.

# Questions & answers

## Technical details concerning the Microswitch

### Does the microswitch work with every kind of fuse?

No, Microswitch functionalities are guarantee only using fuses with striker pin.

### Microswitch assembly and didassembly steps

1- assembly

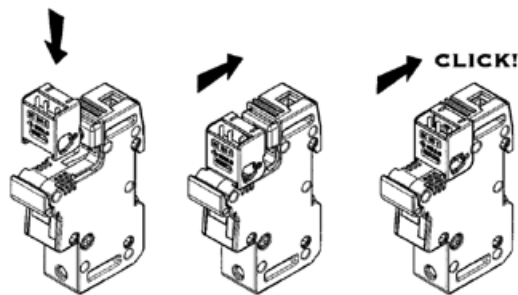

2- disassembly

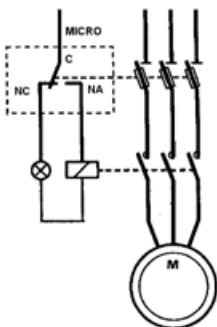
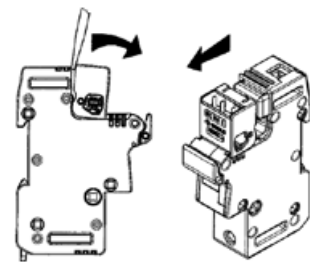

### Microswitch functions enabled thanks to fuses with striker pin

- a - Fuse blown : indicates fuse break condition
- b - Pre-opening: indicates when the fuseholders cover is open
- c - Presence: indicates when the cover is closed but there is no fuse inside



### State of the E930/MCR microswitch contact

Closed fuseholders with fuse

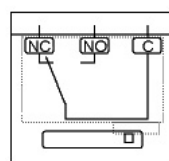

Open fuseholders without fuse

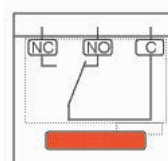

# Contact us

## **ABB SACE**

**A division of ABB S.p.A.**

**Line Protection Devices**

Viale dell'Industria, 18

20010 Vittuone (MI) - Italy

Tel.: +39 02 9034 1

Fax: +39 02 9034 7609

**[www.abb.com](http://www.abb.com)**

The data and illustrations are not binding. We reserve the right to modify the contents of this document on the basis of technical development of the products, without prior notice.

Copyright 2013 ABB. All rights reserved.

2CSC444002B0203 - 11/2013