

No gears required

ABB's Direct Drive solution meets the challenges of the world's most demanding processes

Markku Haikola

ABB has been delivering drive systems for papermaking machines for over 100 years. This wealth of experience has now yielded a Direct Drive system that incorporates all the features a paper production drive system needs.

This system is based on permanent magnet synchronous motor technology and provides better torque characteristics, very precise speed control and high efficiency without the need for gearboxes, pulse encoders and auxiliary components. In addition, it cuts electricity and lubrication oil consumption and reduces noise levels.

Since its launch in 2001, this breakthrough Direct Drive technology has been recognized as a revolutionary innovation in the papermaking industry. It has won a string of awards, the most recent being the The Marcus Wallenberg Prize, a major international technology award that recognizes, encourages and stimulates groundbreaking scientific achievements within the fields of importance to forestry and forest industries.

Companies are always searching for new ways of cutting costs while at the same time improving accuracy and efficiency. For many manufacturers this means looking for better ways to run their production lines.

Gearbox-driven systems have been used in many production processes, especially those in the paper industry. Unfortunately because of normal wear and tear, they are the source of downtime, which inevitably leads to costly maintenance. In addition, gearboxes are bulky and take up valuable floor space in and around the machine in question. From a papermaker's point of view, what is needed is a solution that requires less maintenance, less energy and less space, and Direct Drive technology is the answer to these needs.

ABB's breakthrough and award-winning Direct Drive technology has been recognized as a revolutionary innovation in the papermaking industry.

A Direct Drive solution not only reduces the number of mechanical drive components required in many applications, but it actually eliminates the gearbox entirely ¹. This in turn leads to lower installation and maintenance costs, improved reliability and system response (because gear backlash has

been removed) and increased system efficiency.

ABB was the first company in the world to develop a full-scale Direct Drive solution for running and controlling papermaking machines and is the recognized leader in providing drive systems for the pulp and paper industry.

Direct Drive – in a league of its own

Standard induction motors, normally designed to run at between 750 and 3,000 rpm are not particularly well suited for low-speed operation. ABB's Direct Drive solution has been designed to overcome this issue.

The solution consists of a permanent magnet synchronous motor controlled by a low-voltage AC drive such as the ACS800 [1]. The permanent magnet motor is directly connected to the load and can deliver more power from a smaller unit. Coupled with the well-known synchronous Direct Torque Control (DTC)¹⁾ motor control **Factbox 1**, the solution provides better torque characteristics, very precise speed control and high efficiency without the need for gearboxes, pulse encoders and auxiliary components.

The permanent magnet motor follows a radial flux design, which can be either air or water cooled with a permanent magnet rotor. The output power of the motor varies between 17 and 2,500 kW, while the motor voltage can go up to 690 VAC. In most cases, the motor is no bigger than an induction

Factbox 1 Direct Torque Control (DTC)

Direct Torque Control – or DTC – is the most advanced AC drive technology developed by any manufacturer in the world and has replaced traditional open- and closed-loop type pulse-width modulation (PWM) drives. It is called direct torque control because it describes the way in which the control of torque and speed are directly based on the electromagnetic state of the motor but is contrary to the way in which traditional PWM drives use input frequency and voltage. DTC is the first technology to control the “real” motor control variables of torque and flux. Because these parameters are directly controlled, there is no need for a modulator – as used in PWM drives – to control the frequency and voltage. This in turn dramatically speeds up the response of the drive to changes in required torque. DTC also provides precise torque control without the need for a feedback device.

High motor efficiency is a trade-off with variable-speed drive efficiency. The total system efficiency is affected by the switching frequency of the variable-speed drive (VSD). Using a low switching frequency will deliver higher VSD efficiency, but will result in greater losses in the output filtering or motor. It is therefore crucial to understand how the type of power supply, switching frequency and output voltage, and the motor design, affect total system efficiency. In addition, the type of power supply unit used also affects the amount of losses.

Footnote

¹⁾ A unique feature of DTC is that it optimizes the switching pulses for better overall efficiency.

1 An illustration showing the space-saving benefits of a Direct Drive system over the gearbox method

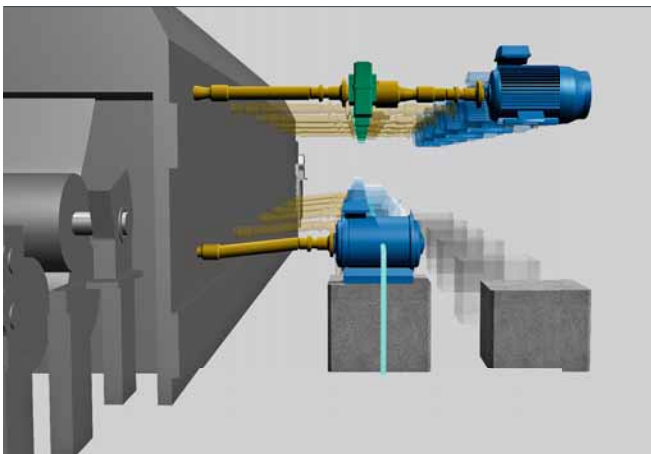

2 The first full-size Direct Drive solution ever installed took place at M-real's Äänekoski mill in Finland



Awards and innovations

machine. In fact, when compared to with an induction motor of the same size, a permanent magnet motor can deliver more than twice the torque to a driven shaft. For example, the output torque of ABB's IEC355 permanent magnet motor (330 kW) is 7,433 Nm²⁾ compared with the 3,417 Nm delivered by a 6-pole induction motor of the same size. The optimal speed rating of permanent magnet motors range between 120 and 600 rpm even though operational speeds could exceed 900 rpm. Motor torque can exceed 44,000 Nm for output power ranges of between 2,000 and 2,500 kW.

The Direct Drive solution consists of a permanent magnet synchronous motor controlled by a low-voltage AC drive such as the ACS800.

The construction of the traditional synchronous motor is more complicated than that of the asynchronous motor, so it requires more maintenance. However, the permanent magnets in the ABB motor simplify its construction by creating a constant flux in the air gap, thereby eliminating the need for the rotor windings and the brushes normally used for excitation in synchronous motors. This solution saves on motor maintenance as the

permanent magnet motor is very robust and the maintenance it requires is similar to that of standard AC induction motors.

Since the permanent magnet motor is synchronous, there is no rotor slip, meaning that very accurate static rotor speeds are possible. In addition, the absence of rotor slip eliminates the need for slip compensation, which in turn helps to improve dynamic motor control. What this means is that the speed of a motor can be controlled with a high degree of accuracy over a wide range.

ABB's permanent magnet motor is quieter than most conventional motors because of the way it is constructed and cooled. If water-cooled frames in particular are used, then the motor can be designed with high power densities and protection classes. Water cooling allows more freedom for drive placement by reducing the exposure of the drive components. This improves overall reliability, especially in harsh environments.

Safety and quality are two attributes that are evident in a permanent magnet motor. The magnet is made from neodymium iron boron (NdFeB)³⁾ and is manufactured to the highest standards in order to obtain the strongest, non-deteriorating magnetic fields needed to produce the desired torques. The good news is that this magnetic

field cannot escape the confines of the motor frame. However, a permanent magnet arrangement always has a strong internal electromagnetic field, producing a terminal voltage while the machine is rotating.

Direct Drive in papermaking machines

In many cases, a decisive factor favoring a Direct Drive solution is the space it saves around the machine. The combination of fewer components and simpler configuration reduces plant engineering hours, facilitates installation, allows more efficient use of floor space, and reduces spare parts inventories.

As permanent magnet technology is helping to eliminate gearboxes across a wide range of industries – for example, it has been successfully used in marine propulsion and wind power generation – the benefits of a Direct Drive solution are of particular importance in the paper industry. Papermaking machines require large numbers of high-accuracy, low-speed drives. Getting rid of the gearbox not only reduces maintenance and space requirements, it also saves energy.

The combination of fewer components and a simpler configuration reduces plant engineering hours, facilitates installation and allows a more efficient use of floor space.

Optimally, the Direct Drive solution should be applied in all sections of the paper making machine. Practical operational speeds, however, are achieved using a mix of conventional induction and permanent magnet motors.

When it all began

The development work for a papermaking machine drive application started in 1995, and the first prototypes were up and running in the lab



Footnotes

²⁾ Rated at 300 rpm

³⁾ NdFeB is the most powerful magnetic material available at room temperature, with high values of flux density at very high values of magnetization. It is also extremely resistant to demagnetization.

The 2009 Marcus Wallenberg Prize winners: Dr. Jouni Ikäheimo, Mr. Vesa Kajander and Mr. Bengt Welin with H.M. King Carl XVI Gustaf of Sweden



Photo: Janne Eriksson

in 1997. By 1999 the DC drive of a dryer section at M-real's⁴⁾ paper mill was replaced by the first factory-made permanent magnet motor. This flawless first installation remained in place for several years.

The board making machine at M-real's Äänekoski mill includes the first full-size Direct Drive solution ever installed **2**. Completed in 2002, it includes both

Factbox 2 The Marcus Wallenberg Prize

The Marcus Wallenberg Prize is an international prize established in 1980 to acknowledge the lifetime activities and memory of Marcus Wallenberg (1899–1982), the late Chairman of Stora Kopparbergs Bergslags AB (now Stora Enso). He was highly respected in financial and industrial circles, both in Sweden and abroad. Each year the prize recognizes a single research breakthrough by one scientist or a small group (normally two to four people) of collaborating scientists. In the view of the Prize Selection Committee and the Board of the Foundation, the selected breakthrough will have a significant effect on the industries. While rewarding the winner, the prize is also intended to stimulate further research around the globe. Every year up to 500 organizations around the world are invited to nominate candidates for the prize. Source: <http://www.mwp.org>

traditional AC motors (for smaller rolls) and permanent magnet motors (for larger rolls running at low speed), like most of the Direct Drive installations. Currently, there are 29 high-powered permanent magnet motors installed at this site.

Further installations can be found in many countries, including Finland, South-Africa, Germany, Spain, Poland, New Zealand, Australia, the United States and Argentina. In fact most European countries with a major paper industry are now on ABB's Direct Drive list.

ABB is the first company to introduce the Direct Drive solution on an industrial scale. The PMC800 is ABB's most recent solution for the drive system, and to date dozens of gearless and encoderless PMC800 Direct Drive systems are running in processes that produce copy paper, newsprint, fluting, uncoated woodfree paper, machine-finished coated paper and coated box board.

An award-winning concept

Since its launch at the Pulp Paper fair in Helsinki in 2001, ABB's Direct Drive solution has been recognized as a revolutionary innovation in the paper-making industry. In the same year it was awarded the Papex Product Innovation Award in Manchester as well as Le Prix Special du Jury du Grand Prix

de l'innovation by L'Association Technique de l'Industrie Papetière⁵⁾ (ATIP) in Grenoble. In 2004, Frost & Sullivan, a global growth consulting company, recognized the concept by awarding it the Motors, Drives and Power Transmission Customer Value Enhancement Award.

On September 29, 2009, the highly respected Marcus Wallenberg Prize **Factbox 2**, a major international technology award, was presented in Stockholm by H. M. King Carl XVI Gustaf of Sweden to three pioneers within ABB, Jouni Ikäheimo, Vesa Kajander and Bengt Welin (retired) for their breakthrough work in the development of the Direct Drive solution.

Markku Haikola

ABB Oy Process Industry
Helsinki, Finland
markku.haikola@fi.abb.com

Footnotes

⁴⁾ M-real is the leading primary fiber paperboard producer and a major paper supplier in Europe. It is part of Metsäliitto Group, one of the largest forest industry groups in the world, owned by a cooperative of 130,000 private Finnish forest owners.

⁵⁾ The Special Jury Prize at the Innovation Awards of the Technical Association of the Paper Industry.

Reference

[1] Salo, J. The attraction of simplicity: Permanent magnet machines are here to stay. *ABB Review* 2/2009, 29–34.