



The Company

We are an established world force in the design and manufacture of instrumentation for industrial process control, flow measurement, gas and liquid analysis and environmental applications.

As a part of ABB, a world leader in process automation technology, we offer customers application expertise, service and support worldwide.

We are committed to teamwork, high quality manufacturing, advanced technology and unrivalled service and support.

The quality, accuracy and performance of the Company's products result from over 100 years experience, combined with a continuous program of innovative design and development to incorporate the latest technology.

The NAMAS Calibration Laboratory No. 0255(B) is just one of the ten flow calibration plants operated by the Company and is indicative of our dedication to quality and accuracy.

EN ISO 9001: 1994



Cert. No. Q5907

ISO 9001: 2000



Cert. No. 9/90A



Cert. No. 0255

Use of Instructions



Warning.

An instruction that draws attention to the risk of injury or death.



Note.

Clarification of an instruction or additional information.



Caution.

An instruction that draws attention to the risk of damage to the product, process or surroundings.



Information.

Further reference for more detailed information or technical details.

Although **Warning** hazards are related to personal injury, and **Caution** hazards are associated with equipment or property damage, it must be understood that operation of damaged equipment could, under certain operational conditions, result in degraded process system performance leading to personal injury or death. Therefore, comply fully with all **Warning** and **Caution** notices.

Information in this manual is intended only to assist our customers in the correct operation of our equipment. Use of this manual for any other purpose is specifically prohibited and its contents are not to be reproduced in full or part without prior approval of Technical Communications Department, ABB.

Health and Safety

To ensure that our products are safe and without risk to health, the following points must be noted:

1. The relevant sections of these instructions must be read carefully before proceeding.
2. Warning labels on containers and packages must be observed.
3. Installation, operation, maintenance and servicing must only be carried out by suitably trained personnel and in accordance with the information given. Any deviation from these instructions, will transfer the complete liability to the user.
4. Normal safety precautions must be taken to avoid the possibility of an accident occurring when operating in conditions of high pressure and/or temperature.
5. Chemicals must be stored away from heat, protected from temperature extremes and powders kept dry. Normal safe handling procedures must be used.
6. When disposing of chemicals ensure that no two chemicals are mixed.

Safety advice concerning the use of the equipment described in this manual or any relevant hazard data sheets (where applicable) may be obtained from the Company address on the back cover, together with servicing and spares information.

CONTENTS

Section	Page
1. INTRODUCTION	3
2. PHASE 1 - PRELIMINARY CHECKS	
2.1 EXPLOSION PROTECTION	4
2.2 PRESSURE AND TEMPERATURE LIMITS	5
2.3 OPERATING VOLTAGE LIMITS	5
2.4 ENVIRONMENTAL LIMITS	6
2.4.1 Electromagnetic compatibility (EMC)	6
2.4.2 Humidity	6
2.4.3 Vibration resistance	6
2.4.4 Shock resistance	6
2.4.5 Wet and dust-laden atmospheres	6
2.4.6 Fill fluid warning	6
2.5 CORROSION	6
2.6 SPECIAL SERVICES	6
3. PHASE 2 - TRANSMITTER INSTALLATION	
3.1 TRANSMITTER LOCATION	7
3.2 TRANSMITTER MOUNTING	9
3.3 ROTATION	11
4. PHASE 3 - TRANSMITTER WIRING	
4.1 PROTECTIVE GROUNDING	12
4.2 ELECTRICAL CONNECTIONS	12
4.3 SUPPLY WIRING REQUIREMENTS	13
5. PHASE 4 - TRANSMITTER OPERATION	
5.1 FLOW MEASUREMENT	14
5.2 LEVEL MEASUREMENT	15

1. INTRODUCTION

This document provides basic instruction for the installation and commissioning of the ABB 2600T differential pressure transmitter. This transmitter is connected to a process by means of impulse lines and can measure Pressure, Differential pressure or Absolute pressure. The measurement is transmitted to a control system by means of a 4-20 mA signal with a superimposed digital signal (HART) or by means of a digital transmission protocols (PROFIBUS or FOUNDATION Fieldbus). The measure can also be indicated by means of one of the (optional) local or remote displays.

Instructions for preliminary checks, proper transmitter location, installation, wiring, power-up and zero calibration (trimming) of the transmitter are listed in the following.

In order to assure operator and plant safety it is essential that the installation is carried out by personnel suitably trained on the local applicable codes on hazardous location, electrical wiring and mechanical piping. Please read these instructions carefully before installing the transmitter. The protection provided by the equipment may be impaired if the equipment is used in a manner not specified.

For more information refer to the reference manual (document [26X_H/N/G/A HART Pressure Transmitters - Operating Instruction](#)) and, where applicable, the manuals relevant to PROFIBUS or FOUNDATION Fieldbus transmitters. These manuals are available also in electronic format on www.abb.com searching for the keyword "IM/*26*" or from local ABB representatives.

PHASE 1 - PRELIMINARY CHECKS

2. PRELIMINARY CHECKS

Before mounting the transmitter, check the compatibility with the following measurement and safety requirements:

- Explosion protection
- Pressure rating
- Operating voltage limits
- Process and ambient Temperature limits
- Environmental limits
- Corrosion

2.1 EXPLOSION PROTECTION

Explosions could result in death or serious injury. Installation of this transmitter in a Hazardous Area (i.e. a potentially explosive atmosphere) must be in accordance with the appropriate local, national, and international standards, codes, and practices.

Please review the approvals and marking of the transmitter shown on the label attached to the transmitter (see figure 1 - Ref. C), note that this is a sample, read the values on the real label; if this label is not present, the instrument is not suitable for installation in Hazardous Areas. It is necessary to check

that all the parameters listed on this label (or on the certificates enclosed with the transmitter) are in accordance with the requirements of the area where the transmitter is going to be installed. See the reference manual for an explanation of each parameter related to "EX SAFETY". In case of any discrepancy do not install the transmitter.

For pressure transmitter with ATEX combined approval, before installation, the transmitter should be permanently marked with the selected Protection Concept (e.g. intrinsically safe or explosion proof) on the safety label. The transmitter can be used only in accordance with this Protection Concept for its whole life.



Note - The transmitter may be used as a safety accessory (as defined by the Pressure Equipment Directive 97/23/EC) i.e. as part of a shutdown system. In this case it is recommended to select the correct fail safe mode for the 4-20 mA signal (as per Namur NE43 recommendation). See also the instructions relevant to fail safe selection (Up/Down scale mode) in the addendum to the instruction manual on "Use of hardware links on the secondary electronics".

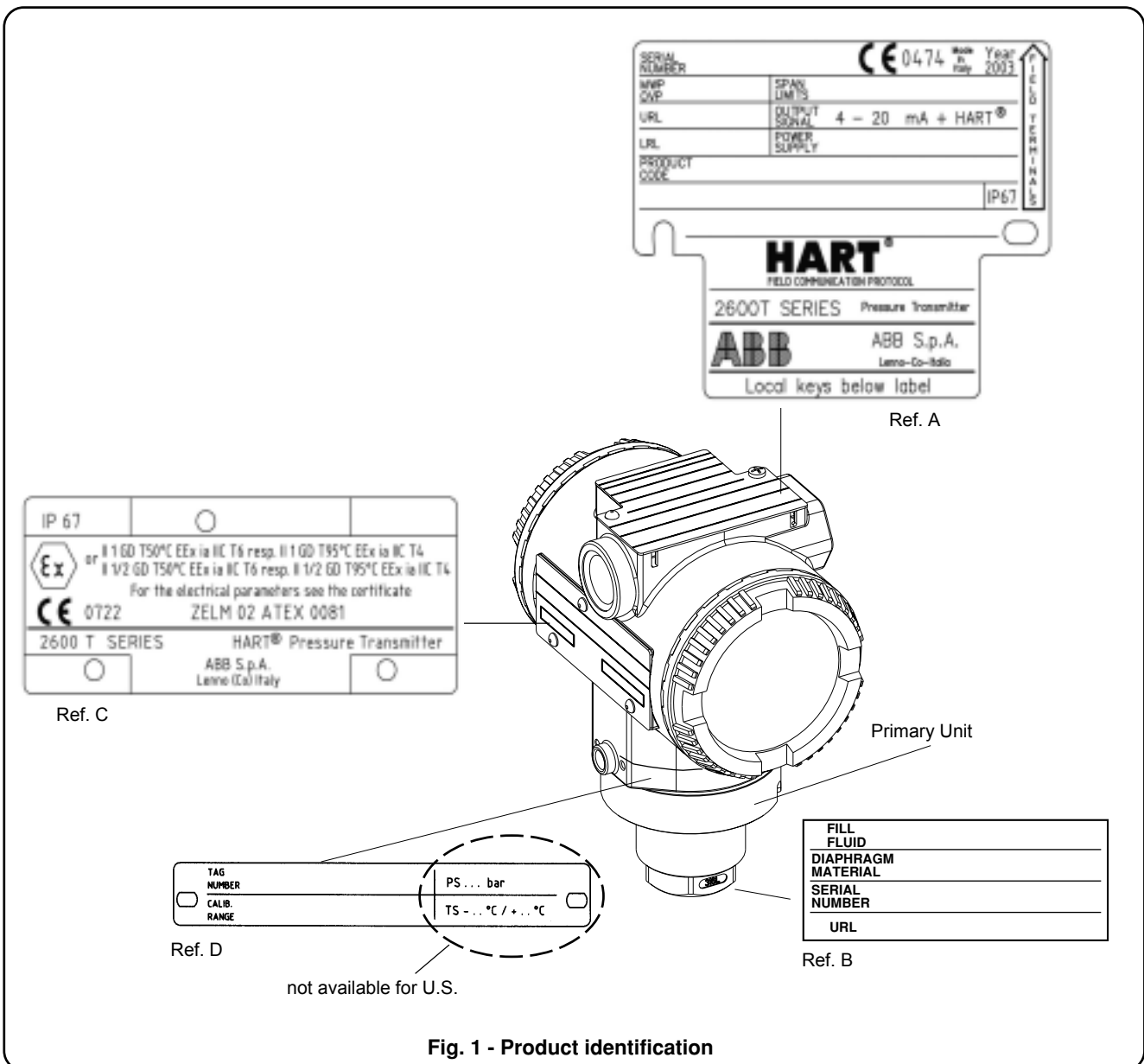

Fig. 1 - Product identification

PHASE 1 - PRELIMINARY CHECKS

2.2 PRESSURE AND TEMPERATURE LIMITS

The maximum allowable pressure (PS) and maximum/minimum allowable temperature (TS) of the pressure transmitter, for the European market are indicated on the tag plate (ref. D of Figure 1), in the U.S. please refer to the instrument data sheets available at: <http://138.221.224.36> searching for "264 and sheet" or from local ABB representatives.

PS and TS are defined according to the European Pressure Equipment Directive 97/23/EC (PED). For Temperature, the listing is for the min and max process temperature limits at which the instrument can be exposed, for Pressure this listing should be considered the maximum working pressure limit to which the transmitter can be exposed without damage (to the transmitter). These limits are valid when the transmitter is installed according to the instructions in this manual.



WARNING ! - For potentially explosive atmosphere applications see the temperature range specified in the certificate/approval relevant to the intended type of protection.

PS values

models 264GS and 264AS

- 1MPa, 10bar, 145psi for sensor codes C, F¹
- 0.5MPa, 5bar, 72.5psi for sensor code L¹
- 6MPa, 60bar, 870psi for sensor code U¹
- 20MPa, 200bar, 2900psi for sensor code R¹
- 90MPa, 900bar, 13050psi for sensor code V¹
- 0.6MPa, 6bar, 87psi for perfluoroelastomer gasket²

models 264HS, 264NS, 264HF, 264NF

- 14MPa, 140bar, 2030psi for sensor codes E, G, H, M¹
- 21MPa, 210bar, 3045psi for sensor codes P, Q, S¹
- 90MPa, 900bar, 13050psi for sensor code V¹

Proof pressure

The transmitter can be exposed without leaking to line pressure of up to:

models 264GS and 264AS

- 1MPa, 10bar, 145psi for sensor codes C, F¹
- 0.5MPa, 5bar, 72.5psi for sensor code L¹
- 6MPa, 60bar, 870psi for sensor code U¹
- 20MPa, 200bar, 2900psi for sensor code R¹
- 90MPa, 900bar, 13050psi for sensor code V¹
- 0.6MPa, 6bar, 87psi for perfluoroelastomer gasket²

models 264HS, 264NS, 264HF, 264NF

- 28MPa, 280bar, 4060psi for sensor codes E, G, H, M¹
- 40MPa, 400bar, 5800psi for sensor codes P, Q, S¹
- 90MPa, 900bar, 13050psi for sensor code V¹

¹ Sensor code is the 6th character of the product code on label Ref. A

² Digit 6 at 9th character of the product code on label Ref. A

Meet ANSI/ISA-S 82.03 hydrostatic test requirements and SAMA PMC 27.1.

Other 264Hx and 264Nx models using direct mount and/or remote seal(s) are compliant to SEP (Sound Engineering Practice).



WARNING ! - In order to assure the proper containment of the process fluid by the transmitter, it is recommended that any part, related to process fluid containment, be supplied only by ABB or authorized agents. The spare parts list is available at: <http://138.221.224.36> searching for "SL/26*" or from local ABB representatives.

The storage conditions must be within the following limits, Lower limit: -50°C (-58°F); -40°C (-40°F) for LCD indicators Upper limit: +85°C (+185°F) otherwise some material such as gaskets may be damaged and cannot assure proper fluid containment.

2.3 OPERATING VOLTAGE LIMITS

The transmitter is designed to provide a current transmission signal of 4 to 20 mA dc on the same wires that are carrying the power supply (two-wire transmitter).

The transmitter operates on a minimum voltage of 10.5 Vdc to a maximum of 42 Vdc and is protected against polarity inversion. The transmitter operates from 10.5 to 42 Vdc with no load.

The operating voltages range for fieldbus versions, both polarity independent, are as follows:

- PROFIBUS PA from 9 to 32 Vdc (17.5 Vdc for EEx ia)
- FOUNDATION Fieldbus from 9 to 32 Vdc (for EEx ia applications 24 Vdc max with entity or 17.5 Vdc max with FISCO)

Some communication problems may occur, in cases the loop resistance is increased by long wires or additional devices like meters, safety barriers, surge protection, remote indicators, etc. If this is the case, please refer to the reference manual for further details (the manual is available at www.abb.com inserting in the "search" tool the keyword "IM/26X") or from local ABB representatives.

For EEx ia and intrinsically safe (FM, CSA and SAA) approvals, the power supply must not exceed 30 Vdc. In some countries the maximum power supply voltage is limited to a lower value.

The transmitter insulation resistance (terminals to earth) is >100MΩ at 1000VDC.



CAUTION Do not arc-weld any pipe-connected to the transmitter as this could break the electrical insulation and damage the electronic part of the transmitter.

PHASE 1 - PRELIMINARY CHECKS

2.4 ENVIRONMENTAL LIMITS

2.4.1 Electromagnetic compatibility (EMC)

Complies with EN 50081-1 for emission and EN 50082-2 for immunity requirements and test;
Radiated electromagnetic immunity level: 30V/m (according to IEC 1000-4-3, EN61000-4-3).
Conducted electromagnetic immunity level : 30V (according to IEC 1000-4-6, EN 61000-4-6).
Surge immunity level (with surge protector): 4kV (according to IEC 1000-4-5 EN 61000-4-5).
Fast transient (Burst) immunity level: 4kV (according to IEC 1000-4-4 EN 61000-4-4).

2.4.2 Humidity

Relative humidity: up to 100% annual average
Condensing, icing: admissible

2.4.3 Vibration resistance

Accelerations up to 2g at frequencies up to 1000Hz (according to IEC 60068-2-26)

2.4.4 Shock resistance

Acceleration: 50g

Duration: 11ms (according to IEC 60068-2-27)



WARNING ! - Transmitters located in hazardous areas must be installed in such a way to prevent the ignition of explosive atmosphere because of impact and friction, even in case of rare events.

2.4.5 Wet and dust-laden atmospheres

The transmitter is dust and sand tight and protected against immersion effects as defined by IEC EN 60529 (1989) to IP 67 (that can be considered equivalent to NEMA 4X and JIS C0920).

2.4.6 Fill fluid warning

Be sure that the fill fluid (indicated on label Ref. B) can mix safely with the process fluid in case of rupture of the sensor membrane.

2.5 CORROSION

Be sure that the process fluid is compatible with the material of the process flanges and sensor diaphragm.
A fluid / material compatibility table is available at www.abb.com (inserting in the "search" tool the keyword "TB/COR") or from local ABB representatives.



NOTE

Data of the table are based on information from manufacturers.
All data is based on a temperature of 20 °C, 70°F unless noted otherwise.
Since corrosion involves many more variables than this table considers, such as trace contaminants, aeration or temperature-concentration profile, stress corrosion cracking and pitting, the table should be used only as a reference in narrowing the choice of materials that merit further investigation. Suitability of a particular material is best determined by field test. At this purpose, please contact our local ABB representatives.



WARNING

For safety purpose the design corrosion allowance of differential pressure instrument flanges is of about 1.5 mm 0.04 in. Therefore from the viewpoint of safe containment of liquids compatible with a specific material according to the table, the expected instrument lifetime is more than 10 years, but the previous note apply.

2.6 SPECIAL SERVICES

In case of Oxygen or Hydrogen or other special services, the transmitter has to be handled with a special care in order to prevent contamination with impure substances. It is recommended to use "sterile" gloves and that the removal of protection bags be done only immediately before the installation. Do not flush with impure fluids.

PHASE 2 - TRANSMITTER INSTALLATION

3. TRANSMITTER INSTALLATION

The following examples are standard mounting locations for instrumentation suitable for these main types of applications:

3.1 TRANSMITTER LOCATION

Level measurement with open tanks

1. Mount the transmitter at the same height or below of the lowest level to be measured.
2. Connect the transmitter to the bottom of the tank.

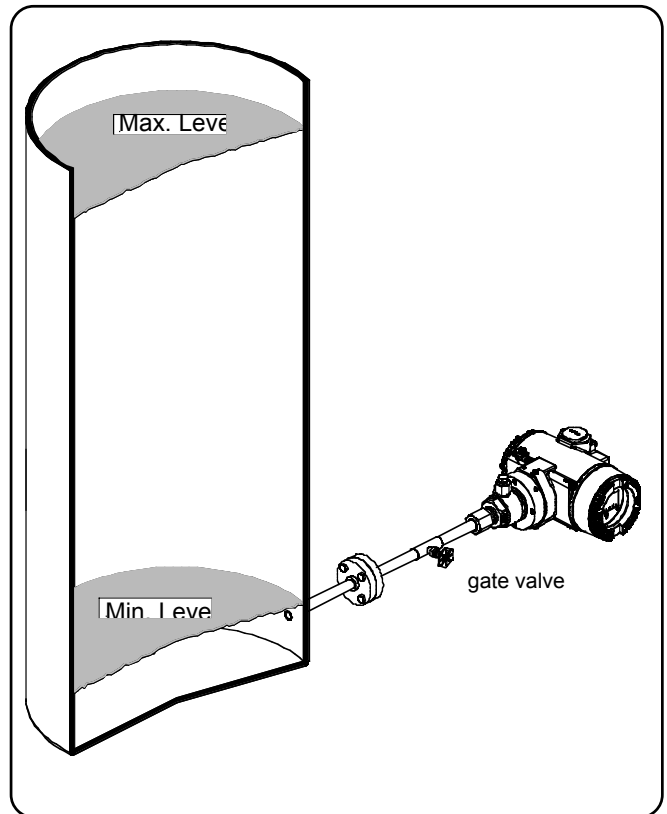

Pressure or absolute pressure measurement of a tank

1. Place the taps in the upper part of the tank.
2. Mount the transmitter above the elevation of the process tap.
3. Connect the transmitter to the tank.

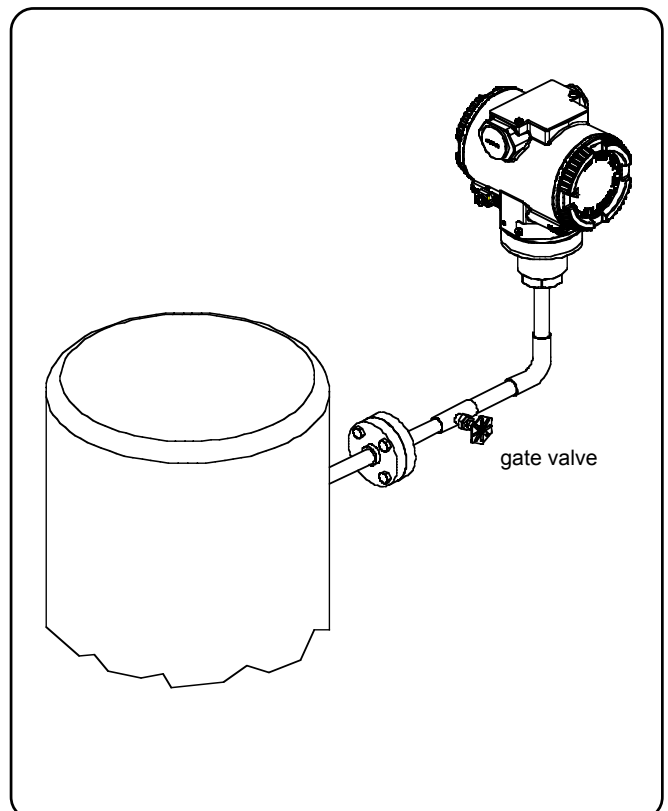

PHASE 2 - TRANSMITTER INSTALLATION

Pressure or absolute pressure measurement of a liquid in a pipe

1. Place the tap at the side of the line.
2. Mount the transmitter beside or below the tap for clean fluids, above the tap for dirty fluids.
3. Connect the transmitter to the pipe.

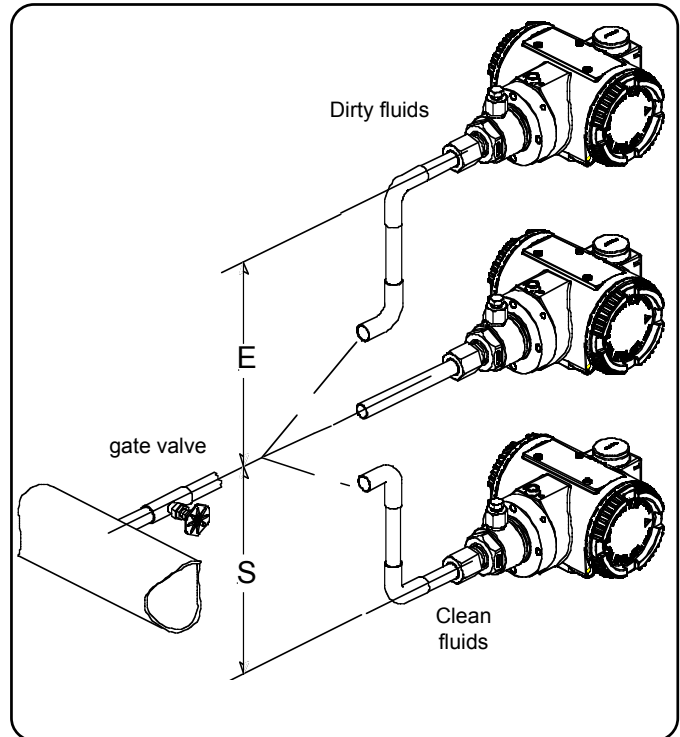

Pressure or absolute pressure measurement of a condensable vapor in a pipe

1. Place the tap at the side of the line.
2. Mount the transmitter below the tap.
3. Connect the transmitter to the pipe.
4. Fill the vertical section of the connecting line to the tap with a compatible liquid through the dedicated filling tee.

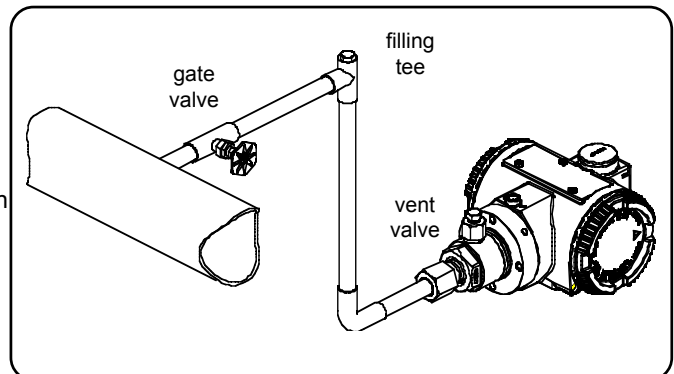

Pressure or absolute pressure measurement of a gas in a pipe

1. Place the tap at the top or side of the line.
2. Mount the transmitter beside or above the tap.
3. Connect the transmitter to the pipe.

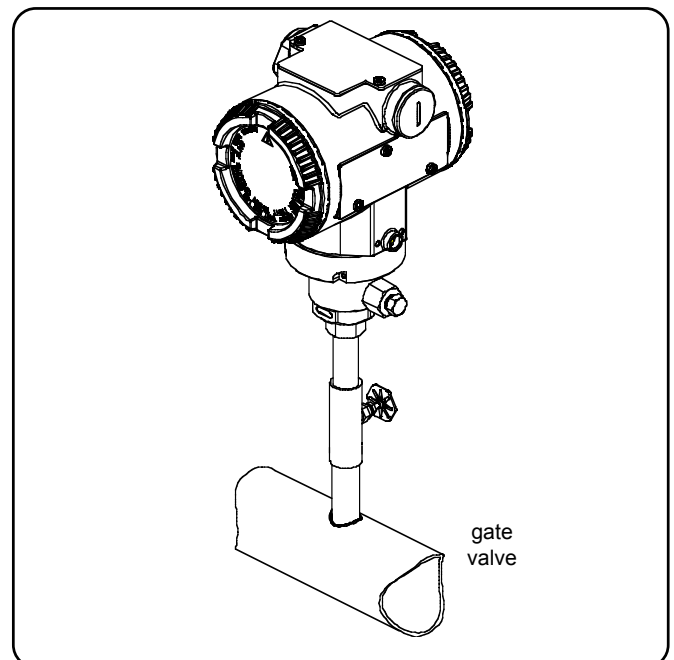

PHASE 2 - TRANSMITTER INSTALLATION

3.2 TRANSMITTER MOUNTING

Orient the process flanges to enable process connections to be made.

It is important to mount the transmitter and to lay the process piping so that gas bubbles, when measuring liquids, or condensate when measuring gases, can flow back into the process.

The vent/drain screw valves has to be ordered higher than the taps on liquid service in order to allow the venting of entrapped gas or below the taps on gas service in order to allow the drain of condensate.

For safety reasons, orient the drain/vent valves so that process fluid is directed down and away from technicians when the valve is used. This can be accomplished by pointing the hole in the outside valve body downward and away.

In addition, consider the need for a testing or calibration input, and provide space for the housing covers to be removed for electrical wiring and maintenance.



WARNING !

Process leaks may cause harm or result in death. Install and tighten process connectors and all accessories (including manifolds) before applying pressure. In case of toxic or otherwise dangerous process fluid, take any precautions as recommended in the relevant Material Safety Data Sheet when draining or venting. Use only a 12 mm (15/32 ") hexagonal spanner to tighten the bracket bolts.

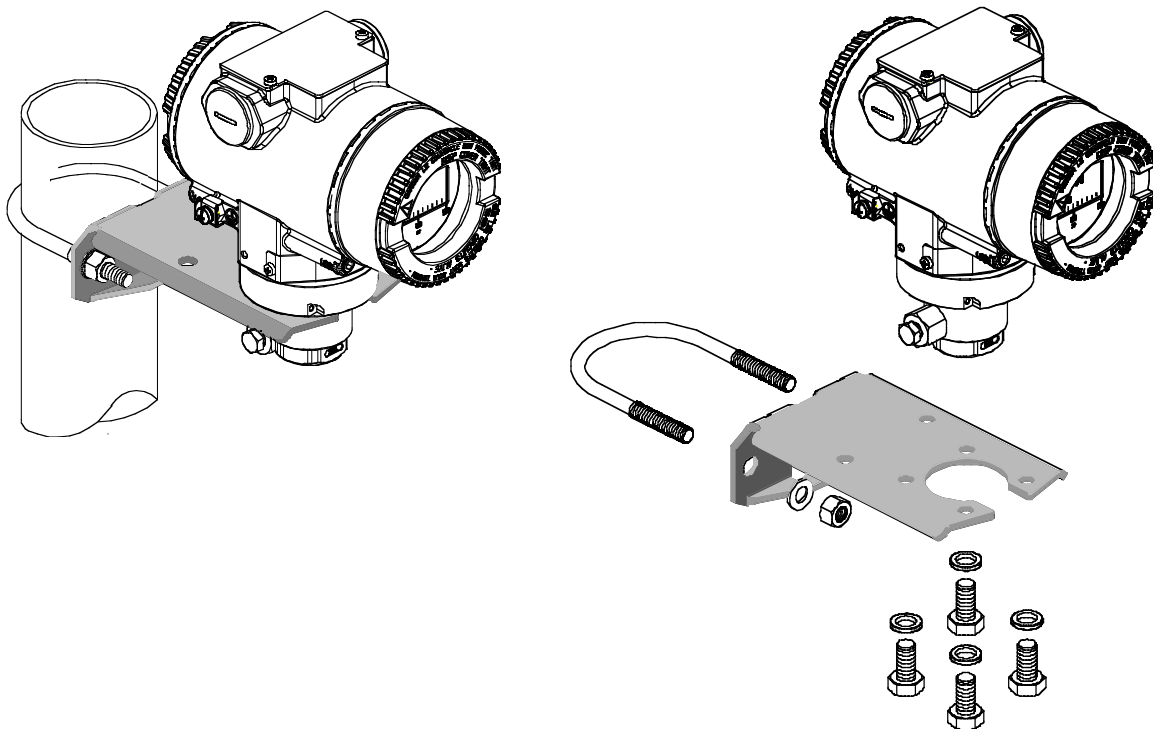

Traditional (Barrel) housing vertical mounting with bracket for vertical (option B1 and B2).

PHASE 2 - TRANSMITTER INSTALLATION

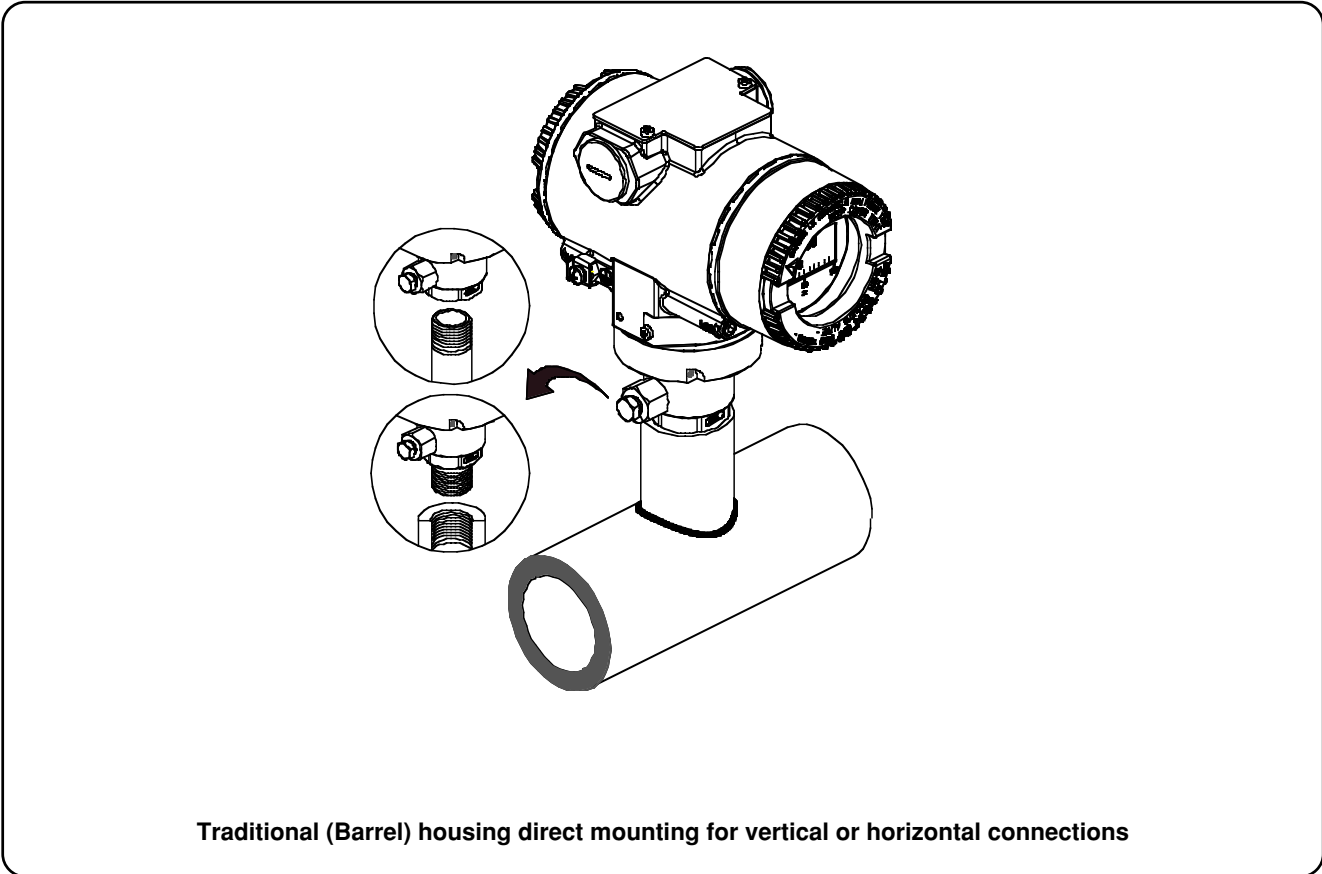
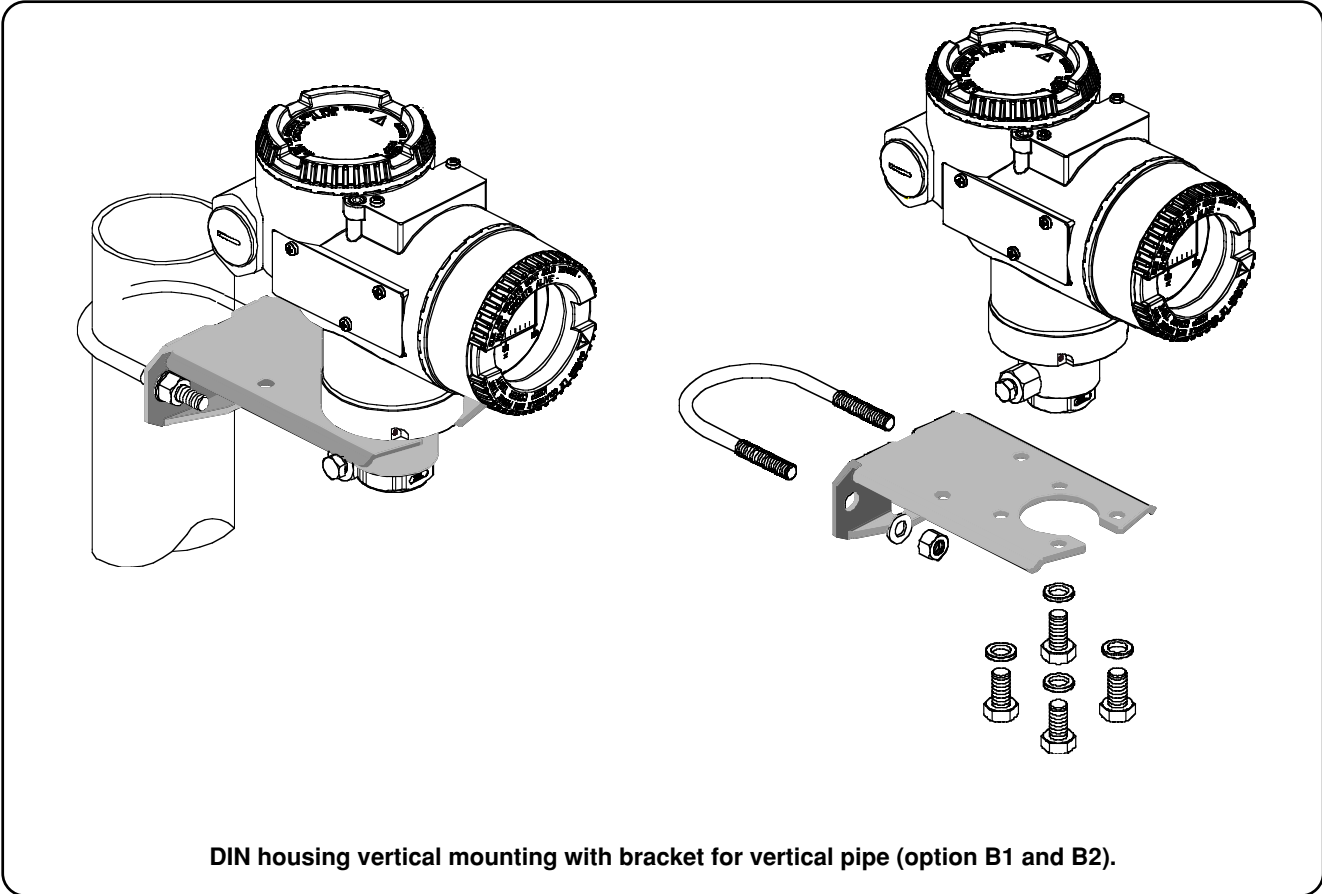

PHASE 2 - TRANSMITTER INSTALLATION

3.3 ROTATION

To improve field access to wiring or the readability of the optional LCD meter it is possible to rotate the Housing and the Meters or the Integral display.

Housing Rotation

1. Unlock the housing rotation set screw by turning it 1 turn (use the 3 mm Allen key supplied with the instrument)
2. Turn the housing clock wise or counterclockwise up to 180° from its original position.



Caution: over rotating will damage the transmitter.

3. Tighter the set screw.

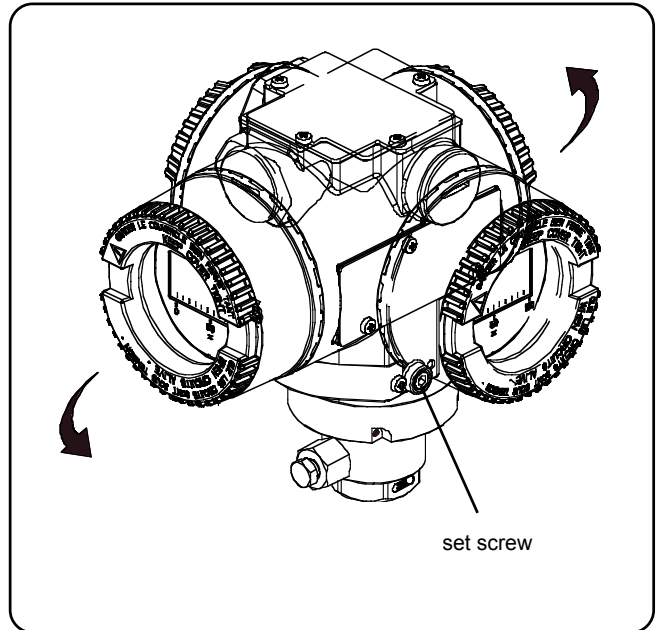

Output Meters rotation

In case an optional meter is installed, it is also possible to rotate the meter 90° degree clockwise or 255° counterclockwise with 15° steps.

Just turn it in the required position gripping around the complete meter to avoid pulling the cover from the base of the meter.

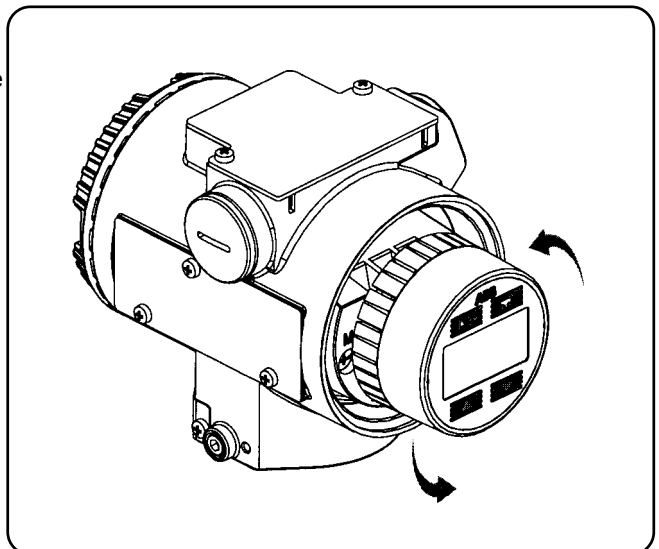

Integral Display rotation

In case an optional integral display meter is installed, it is possible to mount the display in four different positions rotated clockwise or counterclockwise with 90° steps.

This is possible by using one of the four connections located on the back of the display at a 90° distance each from the other.

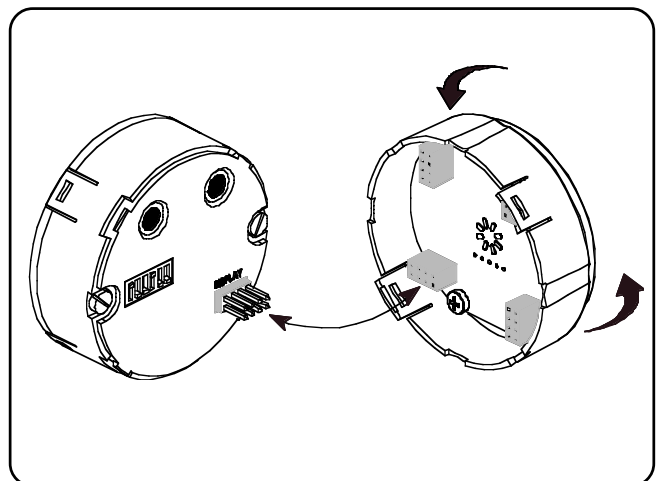

PHASE 3 - TRANSMITTER WIRING

4. TRANSMITTER WIRING

4.1 PROTECTIVE GROUNDING

All transmitters are supplied with an external ground connection for protective grounding.

Wire this ground connection marked with:  to a suitable earth ground.

For a transmitter measuring loop an earth ground should maintain a resistance of 5 ohms or less.

Use a heavy conductor, at least 15 AWG / 1,6 mm² Ø



WARNING ! - A protective grounding connection is absolutely necessary to insure personnel protection, to protect against surge (in case of installation of this option) and to prevent explosions in potentially explosive environment.



WARNING ! - In case the surge protection option is present and the transmitter is installed in a Hazardous area, the transmitter has to be power supplied from a voltage source isolated from mains (galvanic separation). Furthermore the potential equalization for the entire powering cable must be guaranteed since the intrinsic safety circuit of the transmitter is grounded.

4.2 ELECTRICAL CONNECTIONS



WARNING ! - Do **NOT** make electrical connections unless the electrical code designation stamped on the transmitter data plate agrees with the classification of the area in which the transmitter is to be installed. Failure to comply with this warning can result in fire or explosion.

The 4 to 20 mA dc output signal and the dc power supply to the transmitter are carried from the same pairs of wires. The supply voltage at the transmitter terminals must be between the limits of 10,5 and 42V dc.

For EEx ia and intrinsically safe (FM, CSA and SAA) approval power supply must not exceed 30 Vdc. In some countries the maximum power supply voltage is limited to a lower value.



WARNING ! - Electrical shock can result in death or serious injury. Avoid contact with the leads and terminals. High voltage that may be present on leads can cause electrical shock.

Follow these steps to wire the transmitter:

1. Remove the temporary plastic cap from one of the two electrical connection ports located at both sides in the upper part of the transmitter housing.
2. These connection ports have a 1/2 inch internal NPT threads. Various adaptors and bushings can be fitted to these threads to comply with plant wiring (conduit) standards.
3. Remove the housing cover of the "field terminals" side. See the indication on the label on top of the housing. In an Explosion-Proof/Flame-Proof installation, do not remove the transmitter covers when power is applied to the unit.
4. In case an Output meter is present it has to be removed by pulling it out. Grip around the complete meter to avoid pulling the cover from the base of the meter.

5. Run the cable through the cable gland and the open port.
6. Connect the positive lead to the + terminal, and the negative lead to the - terminal.



Note: Do not connect the power across the test terminals. Power could damage the test diode in the test connection.

7. Plug and seal the electrical ports. Make sure that when the installation has been completed, the electrical ports are properly sealed against entry of rain and corrosive vapors and gases.



WARNING ! - Cable, cable gland and unused port plug must be in accordance with the intended type of protection (e.g. intrinsically safe, explosion proof, etc.) and degree of protection (e.g. IP6x according to IEC EN 60529 or NEMA 4x). See also the addendum for "EX SAFETY" ASPECTS AND "IP" PROTECTION. In particular, for explosion proof installation, remove the red temporary plastic cap and plug the unused opening with a plug certified for explosion containment.

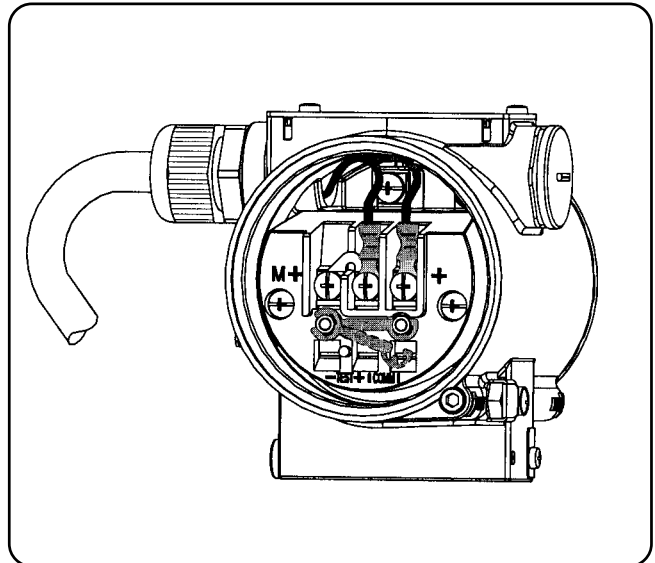

PHASE 3 - TRANSMITTER WIRING

8. If applicable, install wiring with a drip loop. Arrange the drip loop so the bottom is lower than the conduit connections and the transmitter housing. In case an Output meter is present, be sure that the by-pass connection is open, then plug the meter into the appropriate socket.
9. Put back the housing cover, turn it to seat O-ring into the housing and then continue to hand tighten until the cover contacts the housing metal-to-metal.
In EEx-d (Explosion Proof) installation, lock the cover rotation by turning the set nut (use the 2mm Allen key supplied with the instrument).

In case of FF or Profibus connections see the relevant diagram.
For further information find the relevant instruction manuals searching for the keyword "IM/*26*" on www.abb.com or from local ABB representatives.

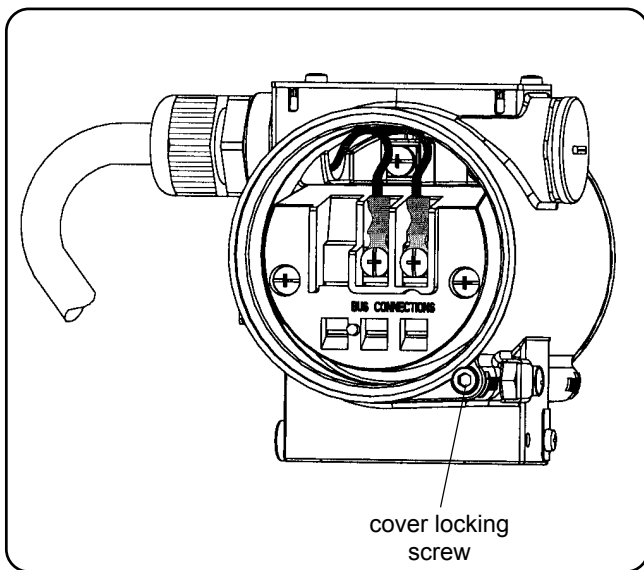

4.3 SUPPLY WIRING REQUIREMENTS

For signal/power connection use twisted, stranded pairs of wiring no 18 to 22 AWG / 0.8 to 0.35mm² \varnothing up to 5,000 feet (1500 meters). Longer loops require larger wire.

If a shielded wire is used the shield should be grounded only at one end, not both ends. In case of wiring at transmitter end, use the terminal located inside the housing marked with:



PHASE 4 - TRANSMITTER OPERATION

5. TRANSMITTER OPERATION

Use the following step to **adjust the transmitter zero**.

5.1 PRESSURE MEASUREMENT

1. Slowly open the gate valve to admit process fluid to primary of side H.
2. Vent all entrapped air (liquid service) or drain any condensate (gas service) from primary using the vent/drain valve.
3. Close the gate valve.
4. Bring the process to the desired zero reading condition, i.e. as an example:
 - a. In case of dry leg open the drain valve to bring the primary to atmospheric pressure
 - b. In case of wet leg slowly open the filling tee (and make sure to have the wet leg completely filled-in).
5. The output should be 4mA dc. If not:
 - a. Rotate the nameplate to get access to the external push buttons.
 - b. Push the zero (Z) button on top of the transmitter (fig. 5.2) for at least 2 seconds.
 - c. The output goes to 4 mA, and if present the integral display, the message "ZERO PASS" will appear.
 - d. If the output is not 4 Ma or the message "WRITE DISABLE" appears on the integral display, check the dip switches settings (you need to open the cover on the electronic side and to pull out the integral display: see fig. 5.1).
 - e. In case of other diagnostic messages, see the reference manual.
6. Close any open filling tee and drain valve.
7. Open the gate valve.

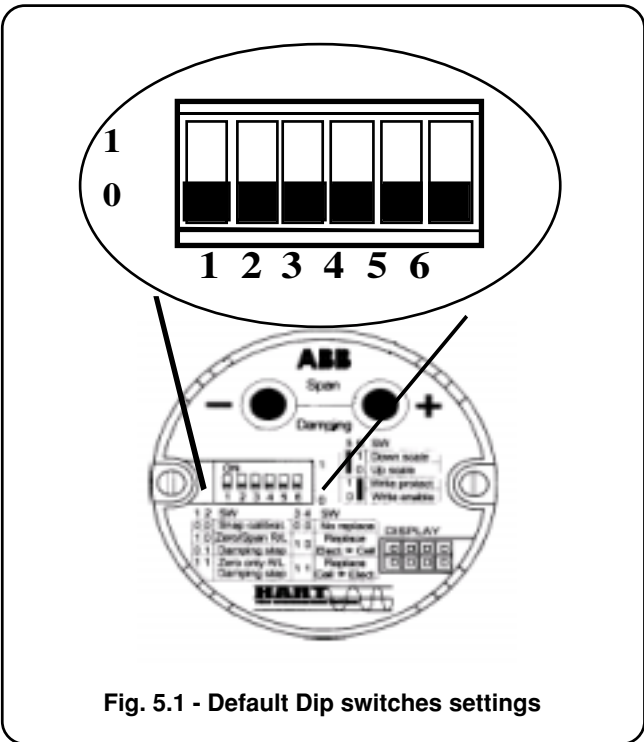
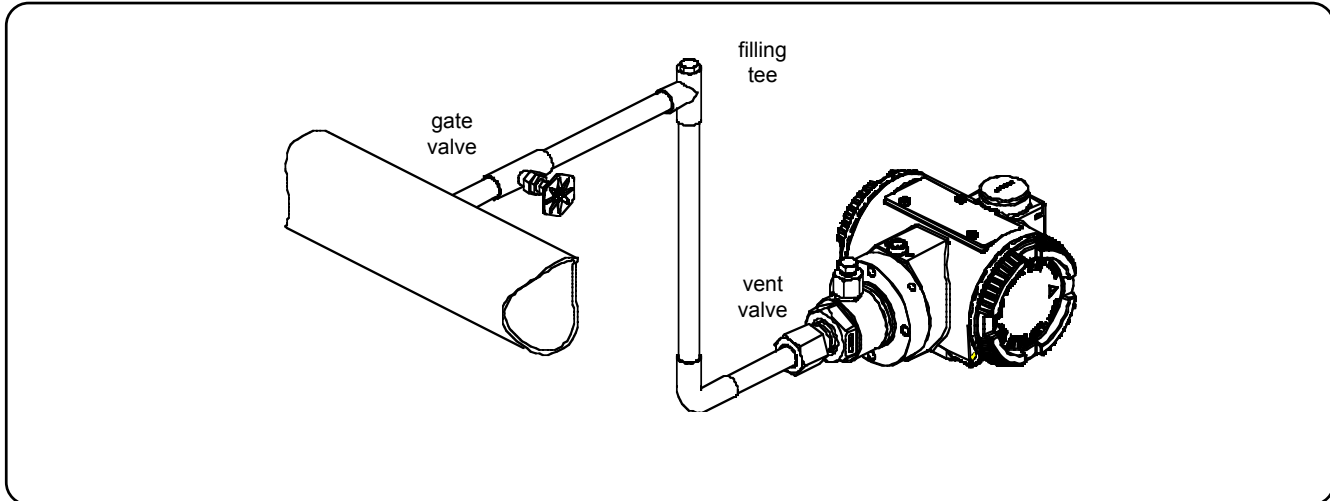

Fig. 5.1 - Default Dip switches settings



Fig. 5.2 - Zero button



PHASE 4 - TRANSMITTER OPERATION

5.2 LEVEL MEASUREMENT

1. Vent all entrapped air from primary using vent/drain valves on the transmitter, then close them.
2. Make sure to have the level in the tank at the required reference (minimum) level.

* Note - In case it is not possible to empty the tank, it is possible to follow the Zero Raise/Lower adjustment procedure described in the reference manual.

3. After venting, the output should be 4 mA dc. If not:
 - a. Rotate the nameplate to get access to the external push buttons.
 - b. Push the zero (Z) button on top of the transmitter (fig. 5.2) for at least 2 seconds.
 - c. The output goes to 4 mA, and if present the integral display, the message "ZERO PASS" will appear.
 - d. If a "WRITE DISABLE" message appears on the integral display, check the dip switches settings (you need to open the cover on the electronic side and to pull out the integral display: see fig. 5.1).
 - e. In case of other diagnostic messages, see the reference manual.

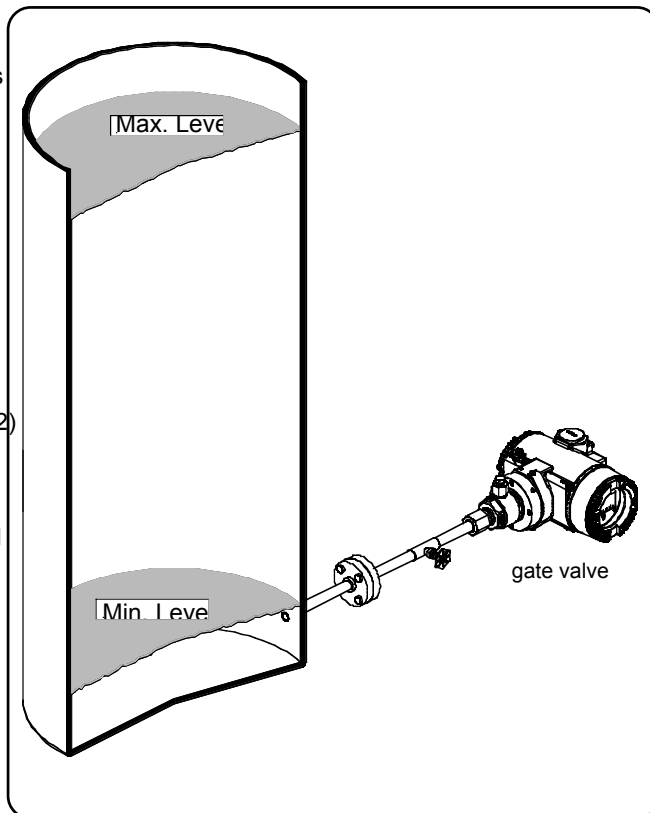



EC-Declaration of Conformity

We
ABB SpA
BU Instrumentation
Via Statale 113
22016 Lenno (Como) Italy

declares under our sole responsibility that the pressure transmitters of 600T and 2600T series, as below specified:

are in compliance with the requirements of 97/23/CE PED Directive

in details, when applicable, have been used for the compliance demonstration, as defined in the annex III of the Directive considering the transmitter as category IV, the D and B modules.

For the D Module has been released by RINA (0474) the certificate n° D/1 2002 MI PP 11

For the B Module have been released by RINA (0474) the certificates:

n° B/1 2002 MI PP 11 for the models:

611ED, 621ED, 611EE, 621EE, 611EG, 621EG, 611EA, 621EA, 611EH, 621EH, 262DS, 264DS, 262PS, 264PS, 262VS, 264VS, 266DS, 268DS, 266PS, 268PS, 266VS, 268VS, 262DF, 264DF, 262PF, 264PF, 262VF, 264VF

n° B/2 2002 MI PP 11 for the models:

614EG, 624EG, 614EA, 624EA, 262NS, 264NS, 262HS, 264HS, 266NS, 268NS, 266HS, 268HS, 262NF, 264NF, 262HF, 264HF

n° B/3 2002 MI PP 11 for the models:

614EGS, 624EGS, 614EAS, 624EAS, 262HSxT, 264HSxT, 262NSxT, 264NSxT

Lenno 14/02/08

Certification Manager
Business Unit Instrumentation
Walter Volo

ABB S.p.A.

Una società del Gruppo ABB
An ABB Group company
Sede Legale
Registered Office:
Via Vitor Pisani, 16
I-20124 Milano - Italy
Tel.: +39 02 2414.1
www.abb.it

Direzione e Uffici Amministrativi
Headquarters and Accounting Services:
20090 Sesto S. Giovanni (MI) - Italy
Via L. Lama, 33
Tel.: +39 02 2414.1
Fax: +39 02 2414.3892
C.P./P.O. Box: 155 Milano
e-mail: seca.ssg@it.abb.com

Capitale Sociale
Share capital:
€ 107.000.000 i.v./fully paid up
P. IVA/VAT: IT 11583900155
Codice Fiscale e n° di Iscrizione del Registro
delle Imprese di Milano/Fiscal Code and
Official Company Book: 00736410155
R.E.A. Milano 1513225

Unità Produttive
Factories:
Bergamo
Frosinone
Garbagnate Monastero (LC)
Lenno (CO)
Marostica (VI)

Santa Palomba (Rome)
S. Marino in Strada (LC)
Vilvane (MI)



EC-Declaration of Conformity

We **ABB SpA**
BU Instrumentation
Via Statale 113
22016 Lenno (Como) Italy

declares under our sole responsibility that the products:

50T Series: 51G/A, 53G/A, 54G/A, 55G/A

600T Series: 611ED, 621ED, 611EE, 621EE, 611EG, 621EG, 611EA, 621EA, 611EH, 621EH, 621SA, 614EG, 624EG, 614EA, 624EA, 614EGS, 624EGS, 614EAS, 624EDS, 611ES, 621ES, 614ES, 624ES, 621EM, S6 Seals.

2600T Series: 262DC, 264DC, 262DD, 264DD, 262DG, 264DG, 262DL, 264DL, 262DH, 264DH, 262DR, 264DR, 262HC, 264HC, 262HD, 264HD, 262HG, 264HG, 262HP, 264HP, 262HR, 264HR, 262NC, 264NC, 262ND, 264ND, 262NG, 264NG, 262NP, 264NP, 262NR, 264NR, 268DC, 268DD, 268HD, 268ND, 268DG, 268DL, 268DH, 268DR, 268HC, 268HG, 268HP, 268HR, 268NC, 268NG, 268NP, 268NR, 262G, 264G, 262A, 264A, 262B, 264B, S264 Seals, 364DS, 364PS, S364 Seals

Deltapi Series: NAA, NAB, NAD, NAE, NBC, NBD, NDA, NDB, NDC, NDD, N6 Seals

Campo Series: JAA, JAF, JAG, JBA, JBG, JCA, JCF, JCG, BBA, DBT

Others: =18311, WPP, WEP

are in compliance with the requirements of 97/23/CE PED Directive

in accordance with article 3, comma 3, of the Directive itself because designed following the sound engineering practice (SEP).

Lenno 14/02/08

Certification Manager
Business Unit Instrumentation

Walter Volo

ABB S.p.A.

Una società del Gruppo ABB
An ABB Group company
Sede Legale
Registered Office:
Via Vittor Pisani, 16
I-20124 Milano - Italy
Tel.: +39 02 2414.1
www.abb.it

Direzione e Uffici Amministrativi
Headquarters and Accounting Services:
20099 Sesto S. Giovanni (MI) - Italy
Via L. Loma, 33
Tel.: +39 02 2414.1
Fax: +39 02 2414.3892
C.P./P.O. Box: 166 Milano
e-mail: sace.ssp@labb.com

Capitale Sociale
Share capital:
€ 107.000.000 i.v./fully paid up
P. IVA/VAT: IT 119889E0156
Codice Fiscale e n° di iscrizione del Registro
delle imprese di Milano/Fiscal Code and
Official Company Book: 00736410150
R.E.A. Milano 1513225

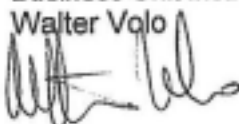
Unità Produttive
Factories:
Bergamo
Frosinone
Garbagnate Monastero (LC)
Lenno (CO)
Marostica (VI)

Santa Palomba (Roma)
S. Martino In Strada (LO)
Vimercate (MI)

PRODUCTS & CUSTOMER SUPPORT

Products

Automation Systems

- *for the following industries:*
 - Chemical & Pharmaceutical
 - Food & Beverage
 - Manufacturing
 - Metals and Minerals
 - Oil, Gas & Petrochemical
 - Pulp and Paper

Drives and Motors

- *AC and DC Drives, AC and DC Machines, AC Motors to 1kV*
- *Drive Systems*
- *Force Measurement*
- *Servo Drives*

Controllers & Recorders

- *Single and Multi-loop Controllers*
- *Circular Chart, Strip Chart and Paperless Recorders*
- *Paperless Recorders*
- *Process Indicators*

Flexible Automation

- *Industrial Robots and Robot Systems*

Flow Measurement

- *Electromagnetic Magnetic Flowmeters*
- *Mass Flow Meters*
- *Turbine Flowmeters*
- *Wedge Flow Elements*

Marine Systems & Turbochargers

- *Electrical Systems*
- *Marine Equipment*
- *Offshore Retrofit and Refurbishment*

Process Analytics

- *Process Gas Analysis*
- *Systems Integration*

Transmitters

- *Pressure*
- *Temperature*
- *Level*
- *Interface Modules*

Valves, Actuators and Positioners

- *Control Valves*
- *Actuators*
- *Positioners*

Water, Gas & Industrial Analytics Instrumentation

- *pH, conductivity, and dissolved oxygen transmitters and sensors*
- *ammonia, nitrate, phosphate, silica, sodium, chloride, fluoride, dissolved oxygen and hydrazine analyzers.*
- *Zirconia oxygen analyzers, katharometers, hydrogen purity and purge-gas monitors, thermal conductivity.*

Customer Support

We provide a comprehensive after sales service via a Worldwide Service Organization. Contact one of the following offices for details on your nearest Service and Repair Centre.

Italy

ABB S.p.A.
Business Unit Measurement Products
Tel: +39 0344 58111
Fax: +39 0344 56278

United Kingdom

ABB Limited
Tel: +44 (0)1453 826661
Fax: +44 (0)1453 827856

United States of America

ABB Inc.
Tel: +1 (0) 755 883 4366
Fax: +1 (0) 755 883 4373

Client Warranty

Prior to installation, the equipment referred to in this manual must be stored in a clean, dry environment, in accordance with the Company's published specification.

Periodic checks must be made on the equipment's condition. In the event of a failure under warranty, the following documentation must be provided as substantiation:

1. A listing evidencing process operation and alarm logs at time of failure.
2. Copies of all storage, installation, operating and maintenance records relating to the alleged faulty unit.

ABB has Sales & Customer Support
expertise in over 100 countries worldwide

www.abb.com/instrumentation

The Company's policy is one of continuous product
improvement and the right is reserved to modify the
information contained herein without notice.

Printed in Italy (01.2009)

© ABB 2012



ABB Ltd

Howard Road, St. Neots
Cambridgeshire, PE19 8EU
UK
Tel: +44(0)1480 475321
Fax: +44(0)1480 217948

ABB Inc.

125 E. County Line Road
Warminster, PA 18974
USA
Tel: +1 215 674 6000
Fax: +1 215 674 7183

ABB S.p.A.

Via Statale 113
22016 Lenno (CO)
Italy
Tel: +39 0344 58111
Fax: +39 0344 56278