

ZX2

Gas-insulated medium voltage switchgear



Your safety first – always!

That's why our instruction manual begins with these recommendations:

- Operate the switchgear as prescribed for its intended purpose.
- Ensure that the technical data on the name plate and in the specification are not exceeded during operation of the switchgear.
- Only install the switchgear in enclosed rooms suitable for electrical equipment.
- With the aim of a smooth installation sequence and ensuring a high quality standard, have installation at site performed by specially trained personnel or managed and supervised by the ABB Service Department.
- Ensure that installation, operation and maintenance are only performed by specialist electricians familiar with this manual.
- Comply in full with the legally recognized standards (IEC / DIN VDE), the connection conditions of the local electrical utility and the applicable safety at work regulations.
- Follow the instructions in the documentation when performing any work on switching devices and switchgear.
- Keep all documentation accessible to all persons concerned with installation, operation and maintenance.
- The user's personnel bear unlimited responsibility in all matters affecting safety at work and the correct handling of the switchgear in accordance with EN 50110 and national regulations.
- Always observe the five safety rules set out in EN 50110 on establishing and securing the off-circuit condition at the place of work for the duration of work on the switchgear. Gas-insulated switchgear are notable for maximum safety, as the circuit-breaker performs the earthing switch function in conjunction with the three position disconnecter. The sequence of safety rules therefore deviates from that proposed in the standard as follows:

Isolate

Check the off-circuit condition

Earth and short-circuit

Secure to prevent reconnection

Cover or guard off adjacent live parts

If you have any further questions on this manual, the members of our field organization will be pleased to provide the required information.

Contents

Page

Standards, regulations, notes, further documents	6
1 Despatch and storage	10
1.1 Condition on delivery	10
1.2 Delivery	10
1.3 Packaging	10
1.4 Handling	10
1.4.1 Handling by fork lift truck	11
1.4.2 Handling by trolley jack	12
1.4.3 Handling by crane	12
1.4.4 Handling by hydraulic lift trolley	14
1.5 Intermediate storage	14
2 Installation of the switchgear at site	15
2.1 Fundamental notes on installation work	15
2.1.1 General site requirements	15
2.1.2 Tightening torques	15
2.1.3 General information on treatment of plug-in connectors with silicone insulating parts	15
2.1.4 Handling sulphur hexafluoride (SF ₆)	17
2.2 Foundation bars	17
2.2.1 Installation of the foundation frame	17
2.2.2 Special considerations with a raised false floor	20
2.3 Assembly of the switchgear	21
2.3.1 Preparatory work	21
2.3.1.1 Checking the SF ₆ pressure in the gas compartments	21
2.3.1.2 Greasing the foundation bars	22
2.3.1.3 Preparing the panels	22
2.3.2 Erection of the panels	22
2.3.3 Closure of extendable busbar sockets	30
2.3.4 Installation of the heat sinks	31
2.3.5 Installation of the top-mounted box for the busbar metering system with isolating device	32
2.3.6 Installation of the pressure relief ducts and the end covers	36
2.3.7 Handling of voltage transformers	36
2.3.7.1 Dismantling voltage transformers (metering 1)	37
2.3.7.2 Installation of voltage transformers (metering 1)	39
2.3.7.3 Dismantling voltage transformers (metering 2)	41
2.3.7.4 Installation of voltage transformers (metering 2)	43
2.3.7.5 Installation of voltage transformers (metering 3)	44
2.3.7.6 Dismantling voltage transformers (metering 3)	49
2.3.7.7 Installation of voltage transformers (metering 4)	50
2.3.7.8 Wiring of the voltage transformers	53
2.4 Connection of cabling and wiring	58
2.4.1 Control cables and wiring	58
2.4.2 High voltage cables	58

2.5	Fitting surge arresters	59
2.6	Fitting blanking plugs	60
2.7	Fitting insulating covers for unused outer cones in double panels	60
2.8	Connecting the main earthing bar	60
2.9	Concluding installation work	60
3	Commissioning	61
3.1	Conditions for commissioning of the switchgear	61
3.2	Energizing the system	62
4	Operation	63
4.1	General notes	63
4.2	Notes on earthing of a feeder panel or system section	63
4.3	Electrical operation	66
4.4	Emergency manual operation	67
4.4.1	Emergency manual operation of the circuit-breaker	67
4.4.2	Emergency manual operation of the three-position disconnecter and the disconnecter	69
4.5	Gas monitoring with density sensors	72
4.6	Operation of the isolating device for voltage transformers	72
4.6.1	Operation of the isolating device for voltage transformers in metering panels	73
4.6.2	Operation of the isolating device for voltage transformers in panels with outer cones	74
4.6.3	Operation of the isolating device in the integrated metering system	76
5	Test procedures	78
5.1	Testing for the off-circuit condition	78
5.1.1	LRM system	78
5.1.2	KVDS and CAVIN systems	78
5.2	Testing for the in-phase condition	78
5.3	High voltage tests	79
5.3.1	Cable tests with DC voltage	79
5.3.2	Voltage test of the main circuit	80
5.4	Secondary protection testing	81
5.5	Protection testing by primary current injection	82
6	Service	83
6.1	Inspection and maintenance of the switchgear installation	83
6.2	Inspection and servicing of individual components	83
6.3	Checking the dimensional accuracy of the control wire settings	84
6.4	Outlet filter	84
7	Actions at the end of the service life	84
8	List of tools	85
9	Working materials, auxiliary materials and accessories	86
9.1	Working materials	86
9.2	Auxiliary materials	86
9.3	Accessories	87
10	Technical data	88

The relevant standards for switchgear over 1 kV and their switching devices can be found in the following table.

Switchgear	IEC 62271-1	Common specifications for high-voltage switchgear and controlgear standards
Switchgear	IEC 62271-200	High-voltage switchgear and controlgear Part 200: A.C. metal-enclosed switchgear and controlgear for rated voltages above 1 kV and up to and including 52 kV
Circuit-breaker	IEC 62271-100	High-voltage switchgear and controlgear Part 100: High-voltage alternating current circuit-breakers
Disconnecter and earthing switch	IEC 62271-102	High-voltage switchgear and controlgear Part 102: Alternating current disconnectors and earthing switches

Take particular account of the relevant standards listed below. Observe the national technical specifications and the accident prevention regulations of the country in which the switchgear is operated.

IEC 60364	DIN VDE 0100	Low-voltage electrical installations
IEC 61936	DIN VDE 0101	Power installations exceeding 1 kV a.c.
DIN EN 50110	DIN VDE 0105	Operation of electrical installations

National technical accident prevention regulations e.g. for electrical systems and equipment and SF₆ installations

Fundamental notes on this manual:

Read the relevant sections of this manual through in full before performing work, so as to ensure correct handling.

Paragraphs in this manual are marked in accordance with their significance. The markings mean the following:

	Hazard warning, meaning in this manual that death or serious injury and considerable damage may occur if the actions described are not performed.
---	---



 Important note, meaning in this manual that injury and damage may occur if the actions described are not performed.

 Attention is drawn to further documents.

Note on safety

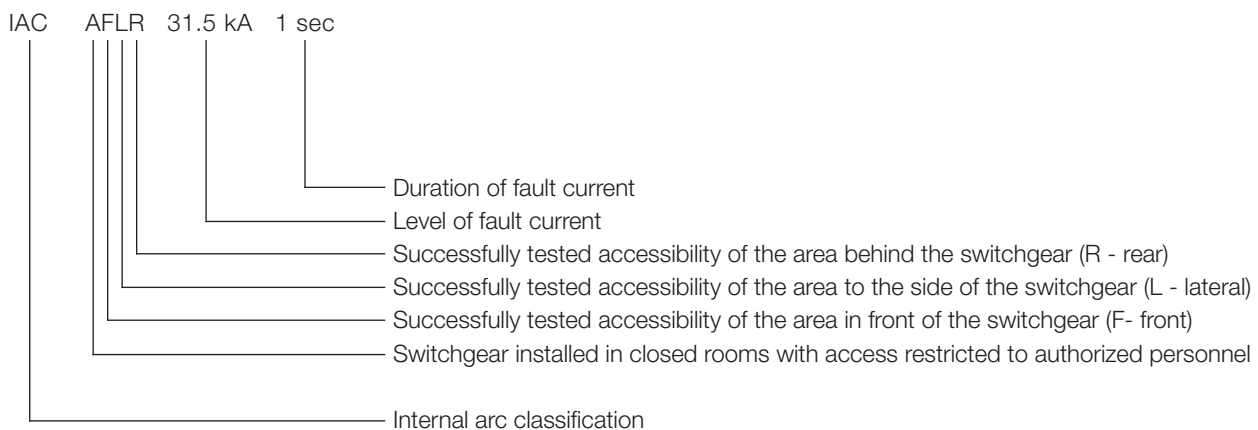
The internal arc classification IAC to IEC 62271-200 confirms a tested degree of operator protection. The information on accessibility of the switchgear as required by IEC 62271-200 can be found on the type plates of the panels. The coding is as follows (exemplary):



	The operator of the switchgear must prevent access by personnel to non-arc classified areas, for instance by issuing instructions.
	Within the ratings stated on the type plate, the switchgear is safe for operating personnel in accordance with IEC 62271-200 when all system components are completely and properly installed.
	Commissioning, servicing and extension work require special attention with regard to safety (see also IEC 62271-200).

Operator safety in accordance with IEC 62271-200 assumes that the conditions stipulated by us are complied with (see also Technical Catalogue TK 602).

With pressure relief into the switchgear room, the IAC qualification requires a switchgear installation consisting of at least four panels. If a pressure relief duct leading to the outside is used, at least two panels are required for the IAC qualification.

You have chosen a gas-insulated switchgear of series ZX2. This switchgear from the ZX range is notable for the following features:

- SF₆ gas-insulated with hermetically sealed pressure systems
- Rated voltages up to 36 kV (40.5 kV)
- Up to 2500 A and 40 kA
- Single busbar and double busbar design
- Up to 4000 A in single busbar design
- Stainless steel enclosures, fabricated from laser cut sheet steel
- Modular structure
- Switchgear with a leakage rate of less than 0.1 % per year
- Integrated routine leakage testing of the panels ex-works
- Indoor installation
- Panel widths 600 mm and 800 mm

Please observe further documents in addition to this manual. The documents relevant to your switchgear are part of the final documentation.

 Installation checklist MC 602/E

 Order documents

- Single line diagram
- Front view
- Construction data if compiled specifically for this order
- Circuit diagrams
- Earthing diagram - switchgear earth to station earth (not part of ABB supply)

 Instruction manuals

- Use of SF₆ insulating gas HB 605 E
- Circuit-breaker VD4X BA 463 E
- Material supplement BA 509 E

 Operating instructions and directions for components, e.g.

- Surge arresters
- Current and voltage transformers
- Current and voltage sensors
- Protection and control devices
- Capacitive indicators.



Do not use cleaning agent containing chlorine for cleaning the switchgear.

If you have technical questions, please contact our service staff

Power technology customer service

Call number +49 180 6222-007

Fig. 1: Feeder panel, 1250 A,
Double busbar, example configuration

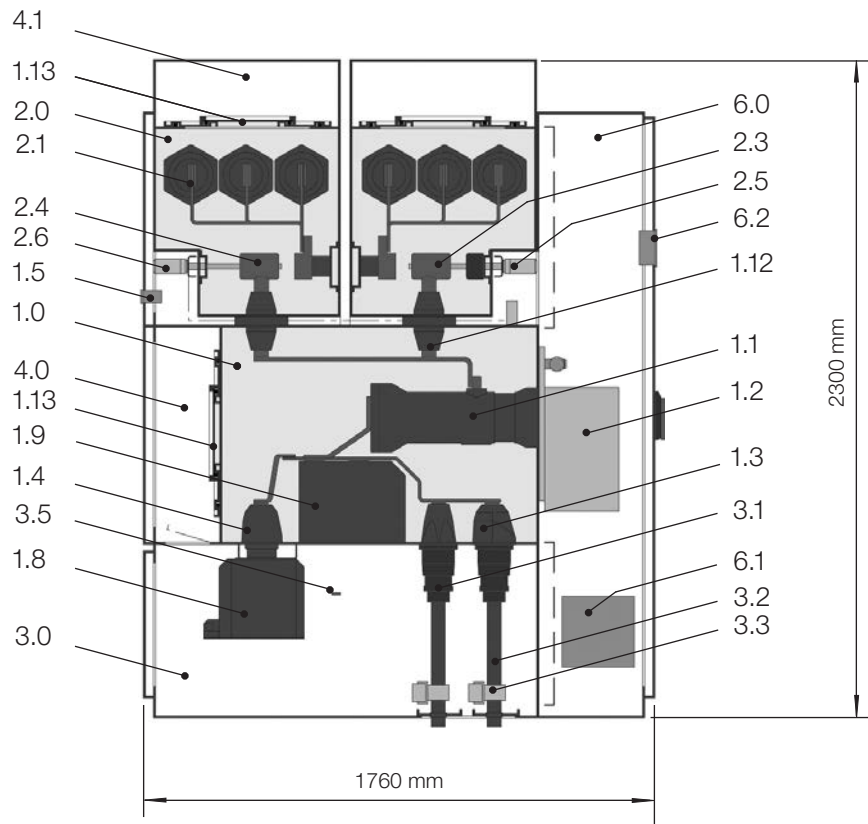

1.0	Circuit-breaker compartment	3.0	Cable termination compartment
1.1	Circuit-breaker pole	3.1	Cable connector
1.2	Circuit-breaker operating mechanism	3.2	High voltage cable
1.3	Cable socket	3.3	Cable fastener
1.4	Test socket (also for use with other plug-in devices)	3.5	Main earthing bar
1.5	Capacitive voltage indicator system	4.0	Pressure relief duct, rear (for circuit-breaker compartment and cable termination compartment)
1.8	Voltage transformer	4.1	Pressure relief duct, top (for busbar compartment)
1.9	Block-type transformer or sensor	6.0	Low voltage compartment
1.12	Bushing, circuit-breaker/ busbar compartment	6.1	Central unit of a combined protection and control device
1.13	Pressure relief disk	6.2	Human-machine interface of a combined protection and control device
2.0	Busbar compartment		
2.1	Busbar system		
2.3	Three position disconnector		
2.4	Disconnector		
2.5	Three position disconnector mechanism		
2.6	Disconnector mechanism		

1 Despatch and storage

1.3 Packaging

1.1 Conditions on delivery

The panels have been routine tested to IEC 62271-200.

- The busbar sockets are closed off with lids to protect them from damage during transport.



The busbar sockets are not insulated in that transport condition. Do not put the switchgear into operation when busbar sockets (e.g. on extendable end panels) are only fitted with transport covers. Close off unused busbar sockets with insulating blanking plugs (see section 2.3.3).

- In normal cases, the gas compartments have been filled with sulphur hexafluoride (SF_6) insulating gas to the rated filling pressure. When airfreighted, however, the panels are delivered with reduced pressure. If delivered by airfreight, increase the pressure to the rated filling pressure before installing the panels (see instruction manual HB 605/E for the procedure to be adopted).
- Busbar compartments fitted at site with heat sinks or top-mounted boxes for integrated busbar metering are filled at the works with nitrogen (N_2). These gas compartments have to be filled with SF_6 when the heat sinks or top-mounted boxes have been installed (see section 2.3.4 and manual HB 605).
- The installation material and accessories and the documentation are packaged separately from the panels.

1.2 Delivery

Check the consignment for completeness and freedom from damage. Document any transport damage found on the waybill and inform us of it immediately. Take photographs of the damage.

The panels have been prepared for transport by the agreed method and for the desired duration of any interim storage required. Details of the length of preservation and the storage location (indoors or outdoors) can be found in the order documents. If the panels are packaged, they are mounted on a pallet and secured to prevent them from slipping.

The possible packaging methods are as follows:

- No packaging
- Packaged in plastic sheeting
- Packaged in plastic sheeting and surrounded by protective cardboard
- Heat sealed in plastic sheeting with drying agent enclosed
- Packaged in aluminium foil in a transport crate with drying agent enclosed

1.4 Handling

The transport units are the panels.



Always handle the panels in the upright position.



Take account of the weight of the transport units when selecting the handling equipment.



Due to the high centre of gravity of the panels, there is a risk that the transport units may tip over! Take all precautions to protect personnel and the material transported.

Only ever handle the panels by

- fork lift truck,
- trolley jack,
- crane, or
- hydraulic lift trolley.

1.4.1 Handling by fork lift truck

The panels can be handled upright on a pallet or by fork lift truck without a pallet. Use lifting sections when handling a panel without a pallet.

Handling with a pallet

 The pallet must rest fully on the forks of the truck or jack. The high centre of gravity means there is a high risk of tipping. Avoid jerky motions.

Handling without a pallet

Fasten one lifting section to each side of the panel. Use five M 8 x 35 cheese head screws with dished washers for each lifting section. See figure 1.4.1.1 for the position of the fastening points.

 The full length of the lifting sections must rest on the forks of the truck (see figure 1.4.1.2). The high centre of gravity means there is a high risk of tipping. Avoid jerky motions.

Fig. 1.4.1.1: Preparation of a panel for handling by fork lift truck

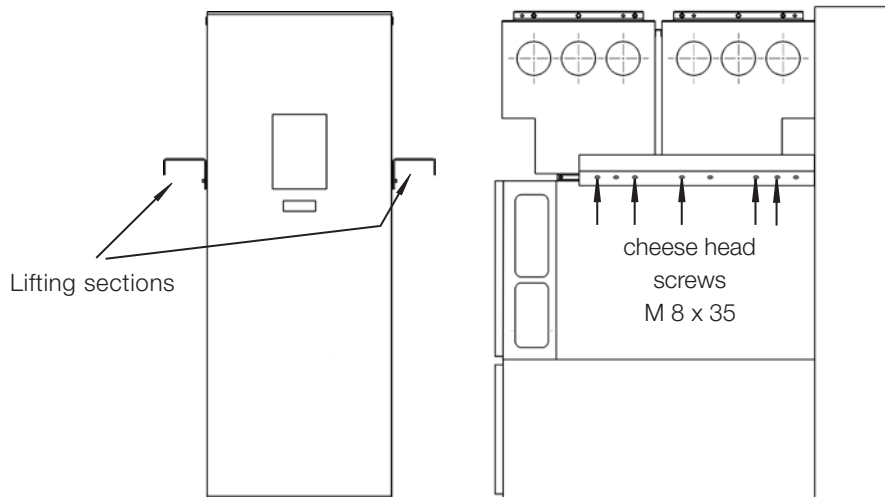
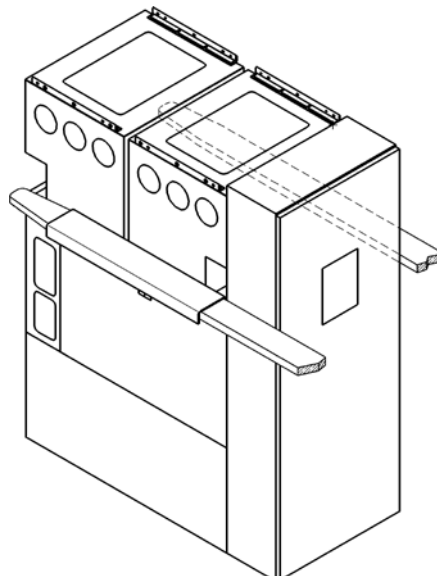

Fig. 1.4.1.2: Handling by fork lift truck



1.4.2 Handling by trolley jack



The panel must be standing on a pallet. The pallet must rest fully on the forks of the truck or jack. The high centre of gravity means there is a high risk of tipping. Avoid jerky motions.

1.4.3 Handling by crane

- Fasten one rope guide to the top brackets of the busbar compartments at each of the left and right using two M 10 x 25 cheese head screws with nuts and dished washers as shown in figure 1.4.3.1.
- Fasten two lifting lugs to the sections between the circuit-breaker compartment and busbar compartment on each of the left and right, using two M 8 x 35 cheese head screws with dished washers as shown in figure 1.4.3.1.
- Fasten lifting ropes with a sufficient capacity (see section 10, Technical data, for panel weights) and sufficient length as specified in figure 1.4.3.2 to the lifting lugs using shackles. Thread the lifting ropes through the cut-outs in the rope guides. The lifting ropes and shackles are not included in the ABB scope of supply.

Fig. 1.4.3.1 a: Lifting lugs and rope guides for handling by crane

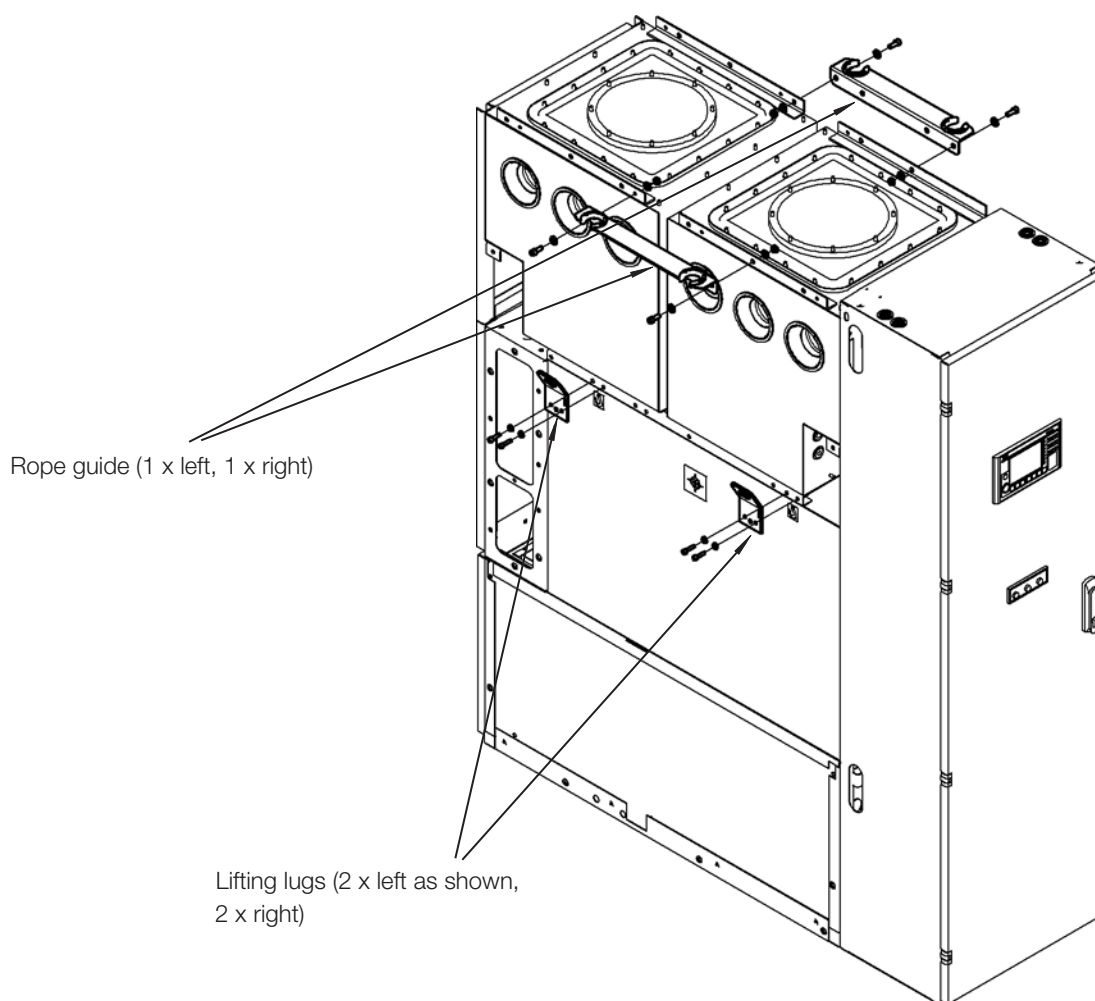
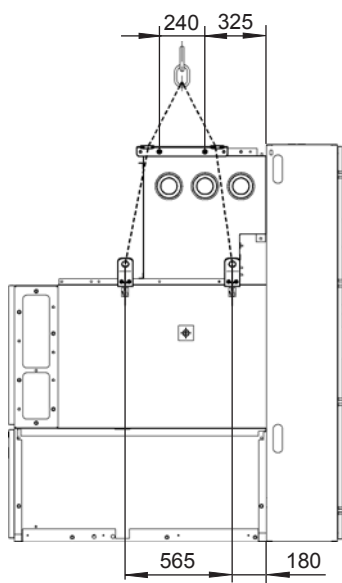
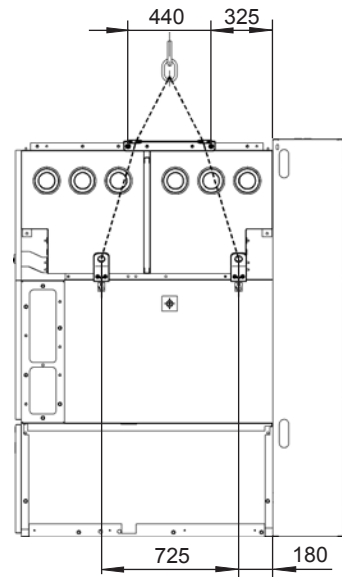

Fig. 1.4.3.1 b: Fastening diagram for lifting lugs and rope guides



Single busbar at the front



Double busbar or single busbar at the rear

Fig. 1.4.3.2: Rope length and rope arrangement for handling by crane

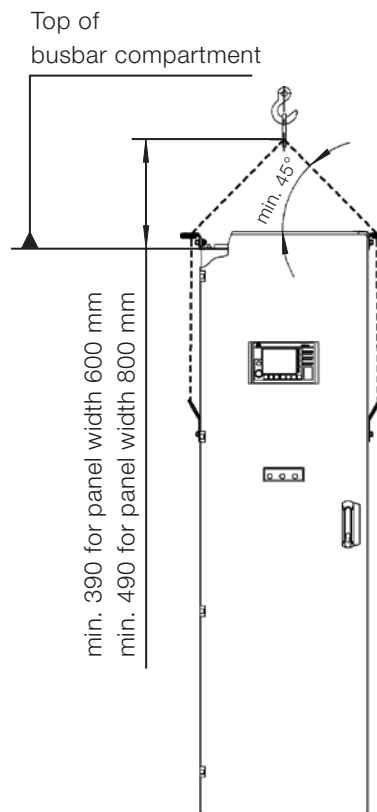

1.4.4 Handling by hydraulic lift trolley

- Fasten a hydraulic lift trolley of suitable capacity to each of the front and rear of the panel (figure 1.4.4.1) in accordance with the manufacturer's instructions.



The high centre of gravity means there is a high risk of tipping. Avoid jerky motions!

Fig. 1.4.4.1: Handling by hydraulic lift trolley

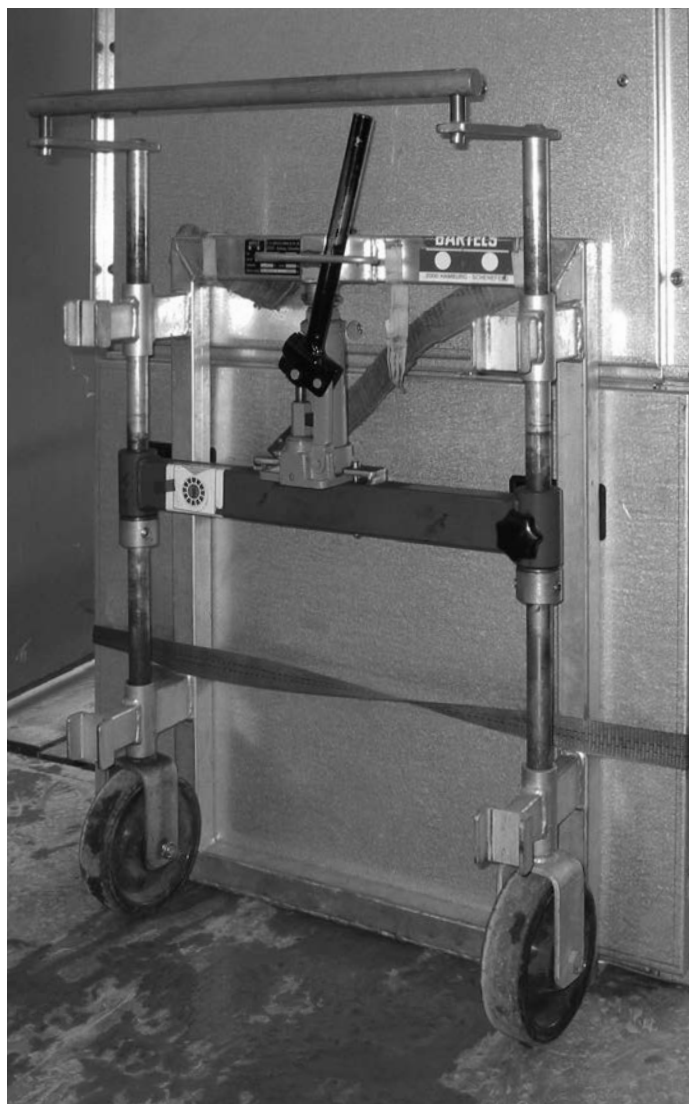

1.5 Intermediate storage

- Store the panels in the upright position.
- Do not stack the panels.
- Protect the transport units from damage.

The conditions for optimum intermediate storage without packaging or with basic packaging are as follows:

- The storeroom must comply with the normal operating conditions for the switchgear installation (see IEC 62271-1).
- Cover the unpackaged panels with protective sheeting, remembering to preserve sufficient air circulation.
- Prevent condensation on the panels by partially opening the packaging and heating the storage room accordingly.

The conditions for optimum intermediate storage with packaging and preservation are as follows:

- Check the packaging for damage.
- Store the transport units in a dry place protected from the weather.
- Contact us if
 - the storage life of the preservation is exceeded,
 - the packaging with preservation is damaged.

2 Installation of the switchgear at site

2.1 Fundamental notes on installation work

2.1.1 General site requirements

At the start of installation, the switchgear room at site must be complete and fitted with lighting and power for the installation work. It must also be lockable, dry, and with good ventilation facilities. All necessary provisions such as openings, ducts, etc. for laying of the power cables must already be in place. Compliance with the conditions for indoor switchgear to IEC 62271-1 must be ensured.

2.1.2 Tightening torques

Use DIN screws of tensile class 8.8. Observe the tightening torques in table 2.1.2.1. The tightening torques apply to unlubricated screw connections.



Please consult the manufacturer's installation instructions for the tightening torques of cable connectors and surge arresters.

	M 5	M 8	M 10
Steel screw in T-nut (foundation frame)		26	
Nut on studbolt	3	12.5	
Steel screw in pulling nut		18 - 24	25 - 48
Nut on hammer head screw in aluminium section		25	
Screw in inner cone socket		20	
Other screws of tensile class 8.8		26	50

2.1.3 General information on treatment of plug-in connectors with silicone insulating parts

This section generally explains the procedure for treatment of silicone insulating parts in the busbar sockets, blanking plugs for the busbars, the silicone insulating parts on plug-in voltage transformers and blanking plugs for voltage transformer sockets. Only treat the silicone parts immediately before use. Section 2.3 indicates when the treated silicone parts are needed.

Please consult the documents from the cable connector manufacturer for details of the treatment procedure for silicone insulating parts on the cable connectors.

Perform the following work to prepare silicone insulating parts for assembly:

- Inspect the silicone insulating parts
- Clean soiled silicone insulating parts
- Grease the insulating parts
- Clean the sockets, the contact tubes and the outer cone

Inspecting the silicone insulating parts



Only remove the relevant component from its protective packaging immediately before assembly.



Check the silicone insulating part for damage prior to installation.



If you note any damage on the silicone insulating part, only use the component after this has been agreed with our service department.

The silicone surface must be free of

- gas bubbles,
- scoring,
- damage,
- abrasions,
- foreign bodies.

Cleaning of soiled silicone insulating parts

Perform cleaning work immediately before assembly of the relevant component as follows:

- Remove surplus or dirty grease from the silicone part with a soft, clean, non-fraying cloth.
- Clean the silicone insulating part when required with intensive cleaner M.X.T. 60 forte and a soft, non-fraying cloth.

 Only use intensive cleaner M.X.T. 60 forte as the cleaning agent.

- Only moisten the cloth slightly with intensive cleaner. Apply only moderate pressure when cleaning the insulating parts of busbar connections. Do not wipe from the black areas towards the light insulating surfaces. By adopting this procedure you avoid transferring black, conductive material onto the light, insulating area.

- After cleaning with intensive cleaner M.X.T. 60 forte, wipe the silicone insulating part with a dry cloth.

 As the cleaner causes the silicone to swell slightly, it then has to dry for approx. 15 minutes in the air.

Greasing the insulating parts

Grease the components immediately before use as follows:

- Use the quantities of assembly paste listed in table 2.1.3.1.
- Silicone insulating parts on the busbar connection: Evenly grease the light, outer areas of the silicone insulating part as shown in figure 2.1.3.1.
- Blanking plugs for the busbar connection: Evenly grease the light, outer areas of the blanking plug as shown in figure 2.1.3.2.

- Silicone insulating parts of plug-in voltage transformers or test plugs: Evenly grease the silicone insulating part as shown in figure 2.1.3.3.
- Silicone insulating parts of the blanking plugs for voltage transformer sockets: Evenly grease the silicone insulating part as shown in figure 2.1.3.4.

Fig. 2.1.3.1: Greasing the light, outer areas of the silicone insulating part on the busbar connection



Fig. 2.1.3.2: Greasing the light, outer areas of the blanking plug for the busbar bushing in the area between the arrows



Fig. 2.1.3.3: Greasing the silicone insulating part of the voltage transformer in the area between the arrows

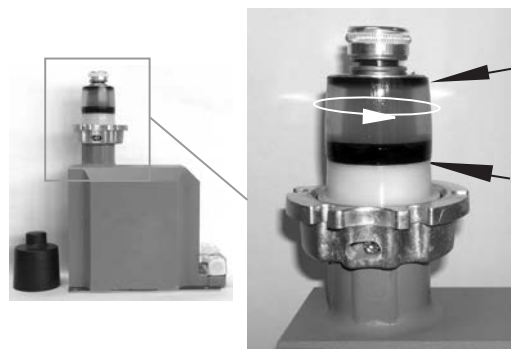
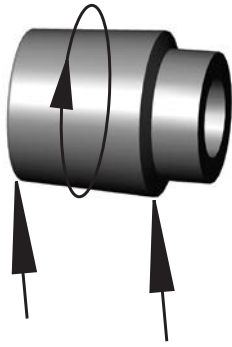

Table 2.1.3.1: Quantities of assembly paste for silicone insulating parts

Component	Quantity of assembly paste to be used
Silicone insulating part on the busbar connection, both sides	Approx. 20 g each insulating part
Blanking plugs for the busbar bushing,	
Silicone insulating parts on voltage transformers,	Approx. 10 g each part
Blanking plugs for voltage transformer sockets,	
Test plugs	

Fig. 2.1.3.4: Greasing the silicone insulating part of the blanking plug for voltage transformer sockets in the area between the arrows



Cleaning the busbar sockets, the contact tubes, the cable sockets, the sockets for voltage transformers, the test sockets and the outer cones

- Degrease and clean the components with intensive cleaner M.X.T. 60 forte.



Assemble the components immediately to avoid soiling.

2.1.4 Handling sulphur hexafluoride (SF₆)

As a rule, no gas work is required during installation.



We recommend that gas work should only be performed by personnel trained in the handling of SF₆. Gas may only be extracted by certified personnel. See manual HB 605 "Use of SF₆ insulating gas" for details on handling SF₆.

2.2 Foundation bars

- When a raised false floor is used, load-bearing sections of the floor frame serve as supports for the panels. No additional foundation frame is necessary.



The slabs of the raised false floor must be fastened to the supporting frame.

- If there is a concrete floor a foundation frame is required. Standard foundation frames supplied by ABB must be embedded in the floor topping.



Maintain the following evenness and straightness tolerances when installing the foundation frame or a raised false floor:

- Evenness tolerance: ± 1 mm / m
- Straightness tolerance: Max. 1 mm / m, but max. 2 mm for the entire length



Consult the order documents for the position of the foundation bars in the switchgear room.

If no standard ABB foundation frames are used, observe the relevant construction and laying drawings for the special frames.

The standard foundation frames are shown in figure 2.2.1.1.

2.2.1 Installation of the standard foundation frame

Standard foundation frames are delivered to site completely pre-assembled.

Installation principle:

The foundation frames are bolted together at the front and rear and three times along the longitudinal sections. Vertical alignment is effected by jacking screws. Brackets are used to fasten the frames to the floor. The foundation frames are finally embedded in floor topping to provide their load bearing capacity.

Detailed description of installation (Fig. 2.2.1.1)

- Position the first foundation frame in the correct location on the concrete floor.
- Align the foundation frame vertically with the four screws (1), taking account of any deviation in floor level in the direction of the foundation frames which are still to be laid.
- Fasten the brackets (2) of the foundation frame to the floor, using one knock-in anchor (5) and one screw (3) with dished washer (4) for each bracket.
- Slide one slot rod (6) into the front slot of the front section and one into the rear slot of the rear section. Fasten the slot rods in position by inserting the grub screws.
- Place the following foundation frame in the correct position on the floor, allowing the inserted slot rods to slide into the sections of the frame to be installed. Bolt the foundation frames together with three M 8 x 100 cheese head screws (7) and nuts and washers. Tighten the grub screws in the slot rods.

Fig. 2.2.1.1: Installation of the floor frame

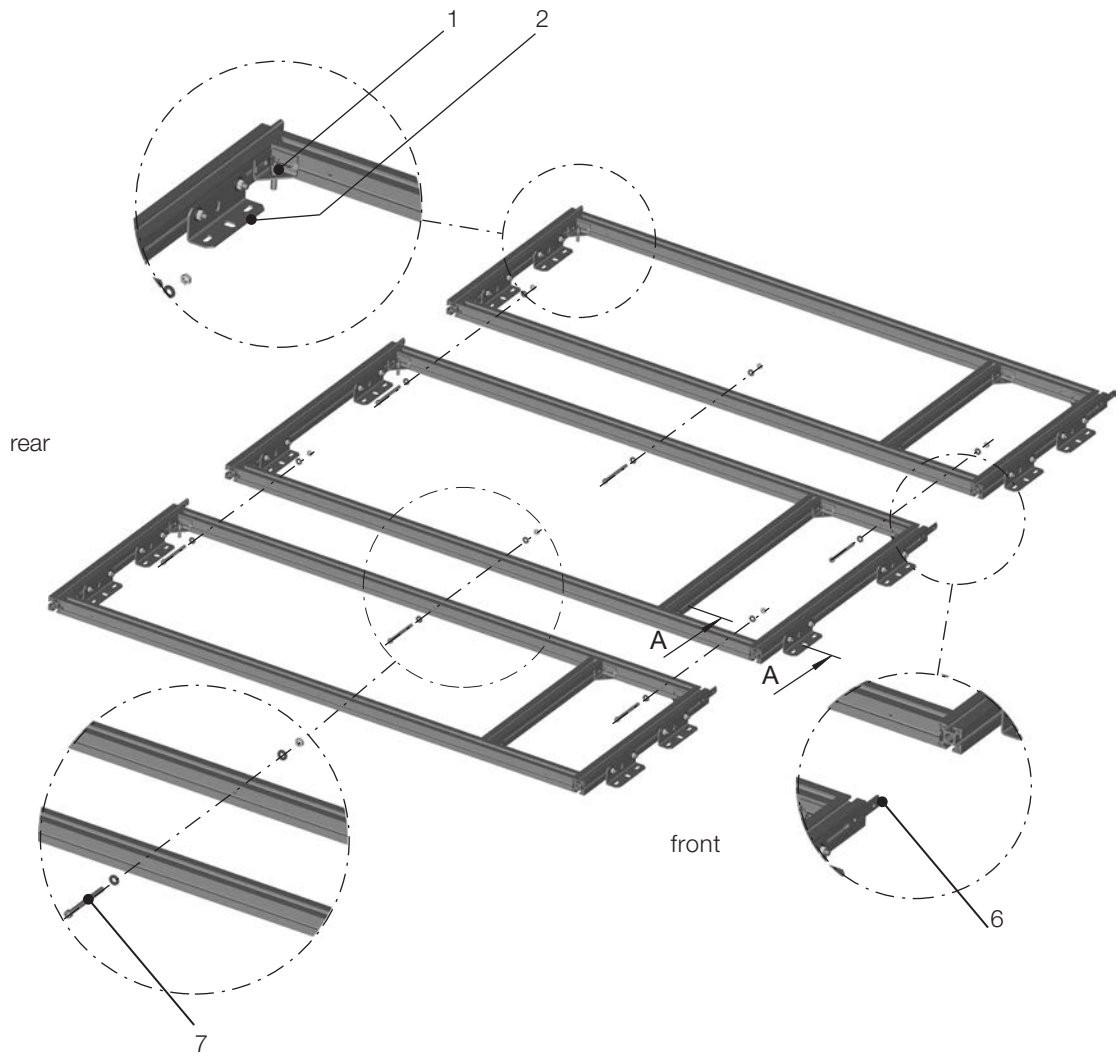

Section A-A

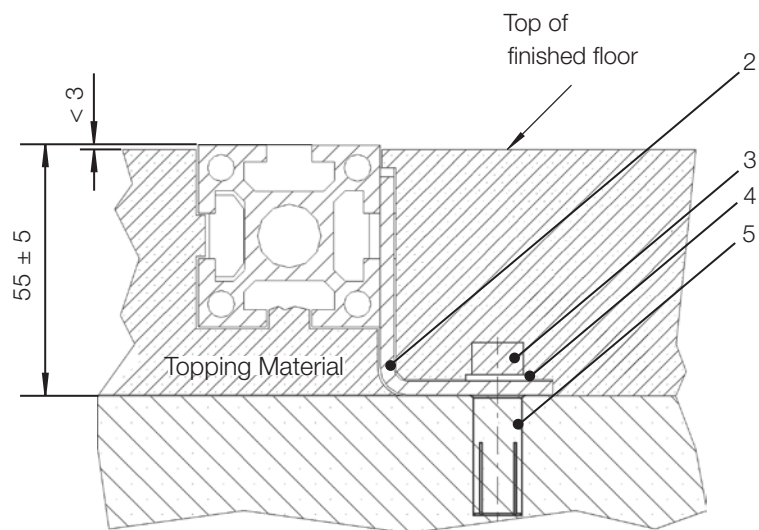

- Align the foundation frame vertically as described above and fasten it to the floor.
- Install the following foundation frames in the same way.
- Earth the completely assembled frame. Further details on this can be found in the order documents.



When applying the floor topping, carefully fill under the foundation frame with topping material.

Fill in the marked area in figure 2.2.1.2 with topping material. (Details on the height of the finished floor can be found in figure 2.2.1.1, section A-A.).

When voltage transformers are used in the cable termination compartment, the panel floor plate needs to be supported. That support is ensured by complete backfilling with topping material in the marked area in figure 2.2.1.2. If the floor plate is not supported by topping material at the rear of the cable termination compartment (e.g. in the case of cable openings elongated to the rear), an additional structural beam is required. The position of that beam can be found in figure 2.2.1.2.

Fig. 2.2.1.2: Plan view of standard foundation frame:
Embedding of the foundation frame in floor topping.

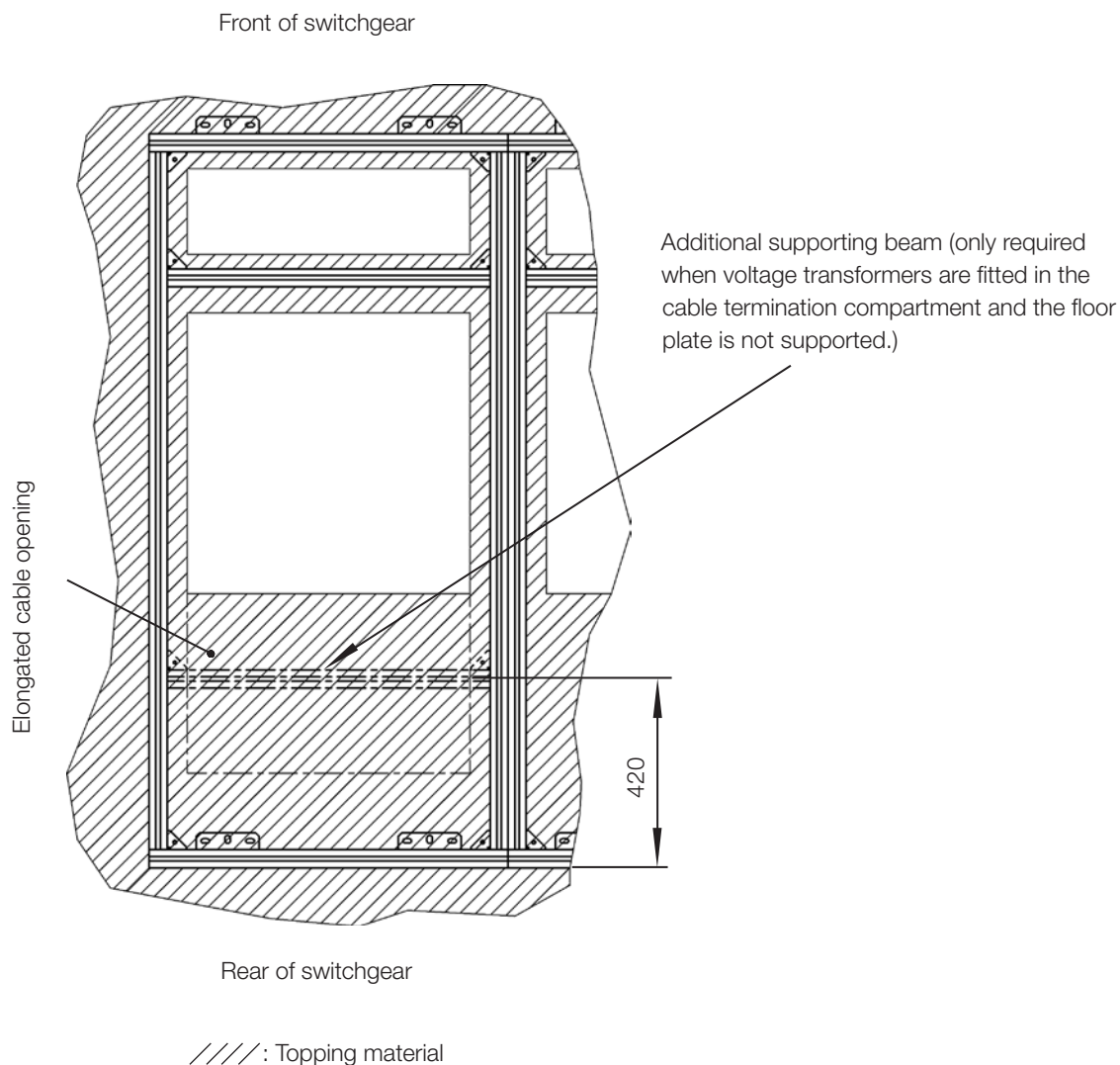

2.2.2 Special considerations with the raised false floor



Raised false floor sections for panels with voltage transformers in the cable termination compartment must be fitted with an additional supporting beam for the voltage transformers.

Fig. 2.2.2.1: Plan view of a supporting beam for the switchgear when a raised false floor is used: Additional supporting beam for a panel with voltage transformers in the cable termination compartment.

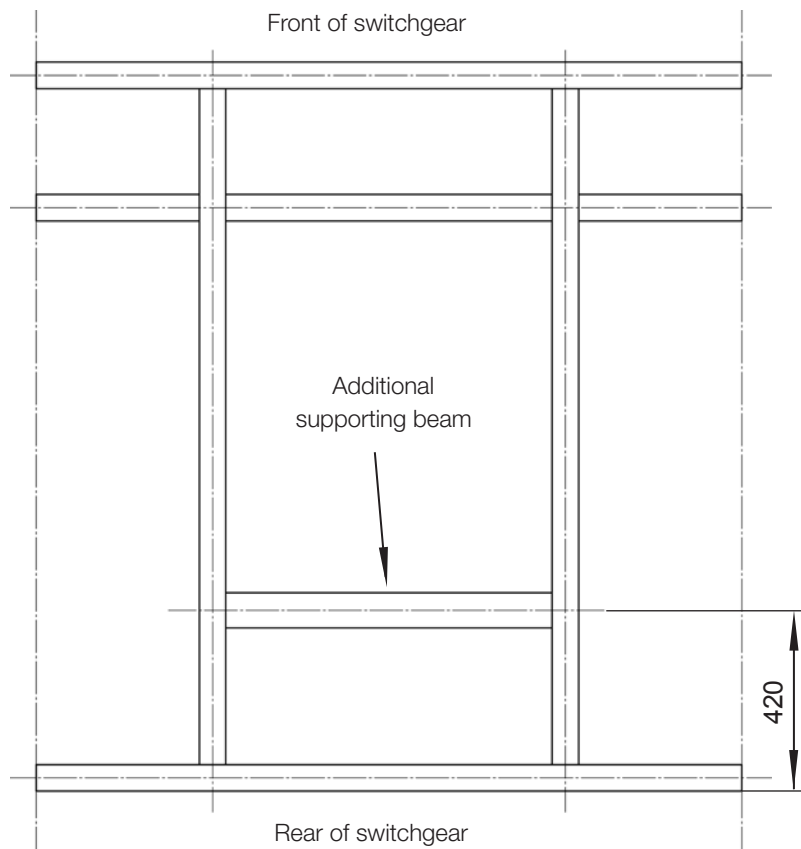

2.3 Assembly of the switchgear

2.3.1 Preparatory work

2.3.1.1 Checking the SF₆ pressure in the gas compartments

- Each panel may consist of one to three gas compartments, depending on the version (see manual HB 605). Each gas compartment is fitted with one filling connector. The filling connectors for the circuit-breaker compartment and the front busbar compartment are located in the low voltage compartment and are accessible from the front when the low voltage compartment door is open. The filling connector for the rear busbar compartment is located behind the top rear cover.
- Check the gas pressure in each gas compartment with a temperature-compensated pressure gauge (see list of tools) before aligning and connecting the panels, as follows:

Fig. 2.3.1.1.1: Filling connector (1) with protective cap (2) in the low voltage compartment

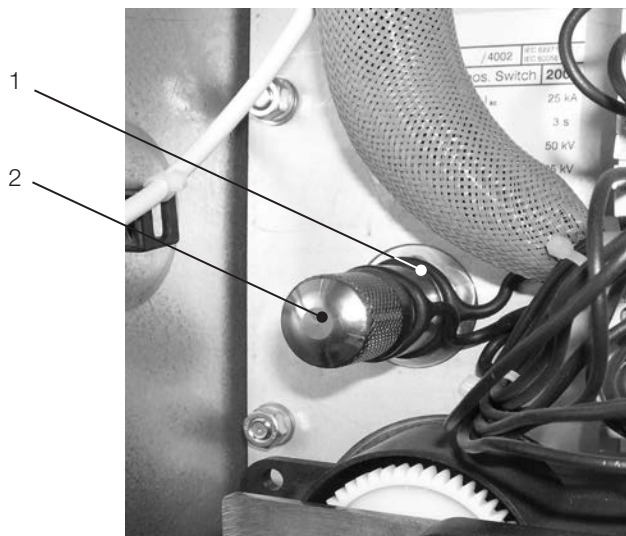

Dismantle the rear covers on the rear busbar compartments if fitted.

- Remove the protective cap (2) from the filling connector (1) by turning it counter-clockwise.



Do not press the valve pin (3) in, as otherwise gas will flow out of the valve.

- While pulling the locking ring (4) outwards, press the coupling of the pressure gauge (5) into the filling connector.
- Check the reading on the scale of the pressure gauge.



The reading must be in the green area of the instrument's scale. If it is not, or if the site altitude is greater than 1000 m, please contact us.

- Remove the pressure gauge by pulling out the locking ring on the filling connector.
- Screw the protective cap onto the filling connector.

Fig. 2.3.1.1.2: Filling connector (1) with valve pin (3)

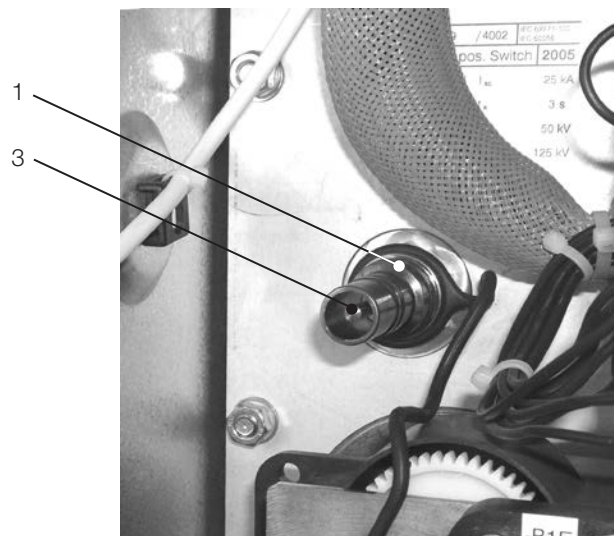



Fig. 2.3.1.1.3: Filling connector with pressure gauge (5) and locking ring (4)



2.3.1.2 Greasing the foundation bars

When a standard foundation frame supplied by ABB is used, remove the protective film. Grease the top surfaces of the foundation frame or raised false floor beams. This facilitates erection and alignment of the panels

2.3.1.3 Preparing the panels

 During installation, do not tread on the marked pressure relief disks in the roof plates of the panels.

- Dismantle the covers on the cable termination compartments and the covers on the pressure relief ducts of all panels.
- Dismantle the rear covers on the rear busbar compartments if fitted.

2.3.2 Erection of the panels

- Screw two guide pins to each of the upper brackets of the busbar compartments on the side of the panel to be extended, using nuts and dished washers (see figure 2.3.2.1 a). In the case of sectionaliser panels in double busbar design, there is a further fastening bracket below the busbar bushings of the circuit-breaker compartment. Fasten the guide pins to that bracket using nuts and dished washers (figure 2.3.2.1 b).

 Guide pins are only to be fitted to one of the panels at the joint between two panels. The guide pins remain in the relevant position after erection of the panels and must not be removed.

- Lightly grease the guide pins for better sliding.
- Set up the furthest panel precisely at the specified position.

Fig. 2.3.2.1 a: Fitting guide pins

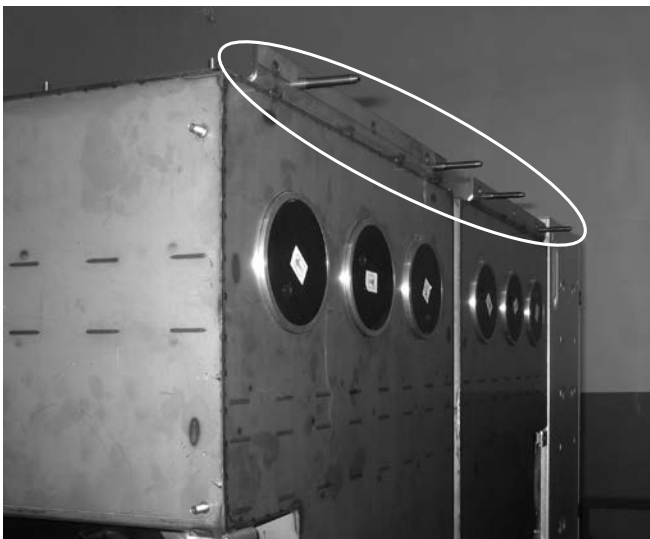
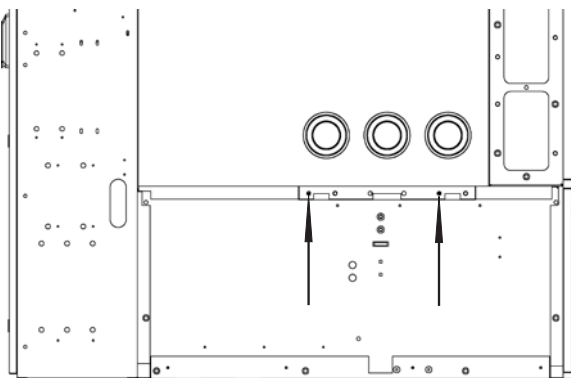

Fig. 2.3.2.1 b: Additional guide pins in a double busbar sectionaliser panel



When the standard foundation frame is used:

- Insert M 8 T-nuts through the holes in the floor plates into the slots in the foundation frame sections. Join the floor plates using washers (1 x washer 8.5 x 30 x 3 and 1 x dished washer 8) and M 8 x 16 cheese head screws to the previously positioned T-nuts (figures 2.3.2.2 a + b).

When a special foundation frame or raised false floor is used:



Fasten the panels in accordance with the instruction documents supplied.

- Remove the protective caps (figure 2.3.2.3) from the busbar sockets.



Check the busbar sockets, the insulating parts and the contact tubes of the relevant panel as specified in section 2.1.3.

Fig. 2.3.2.2 a: Fastening the panel to the foundation frame

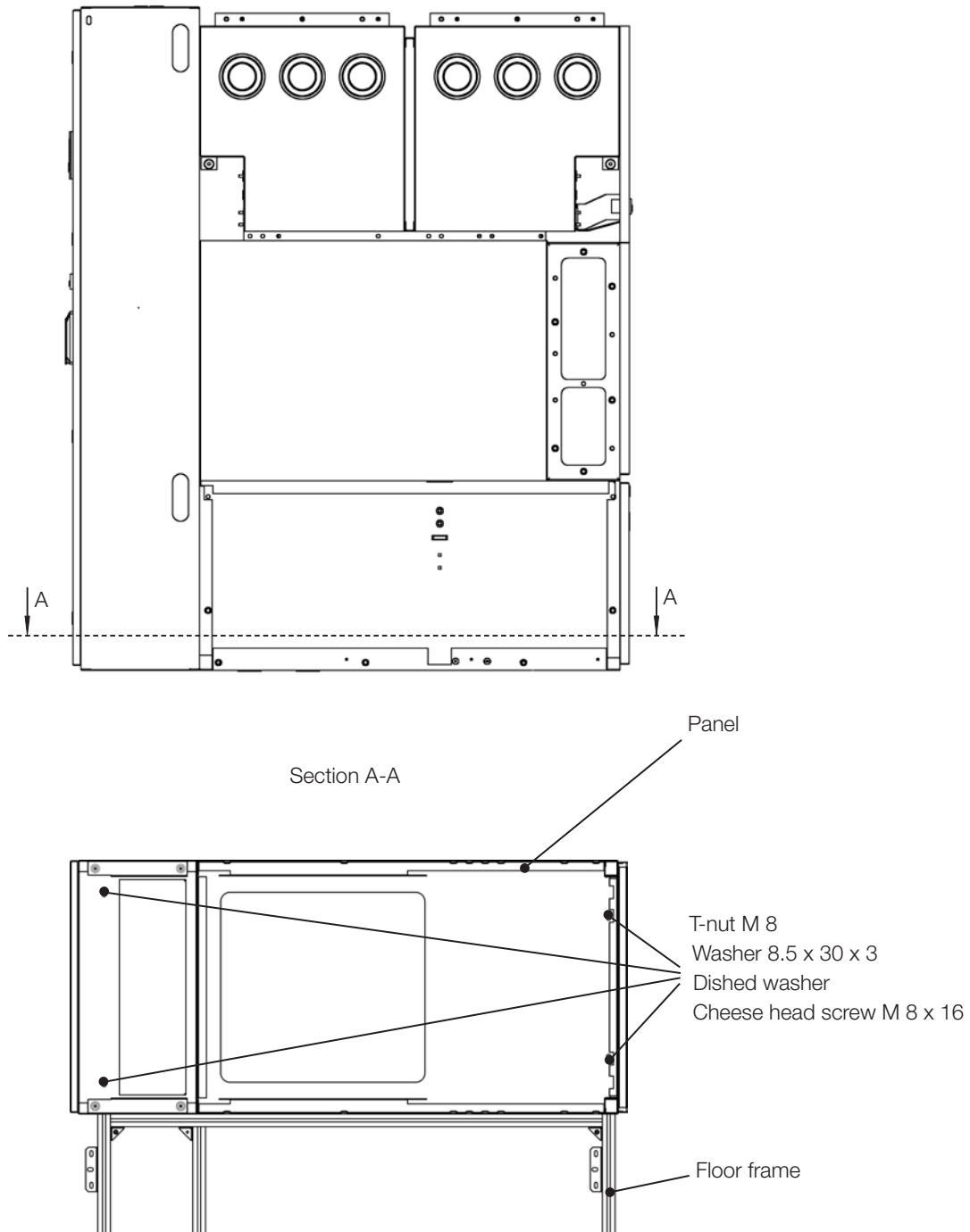
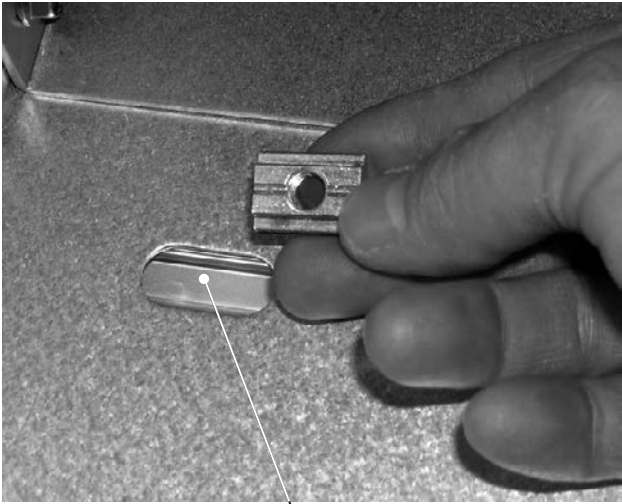
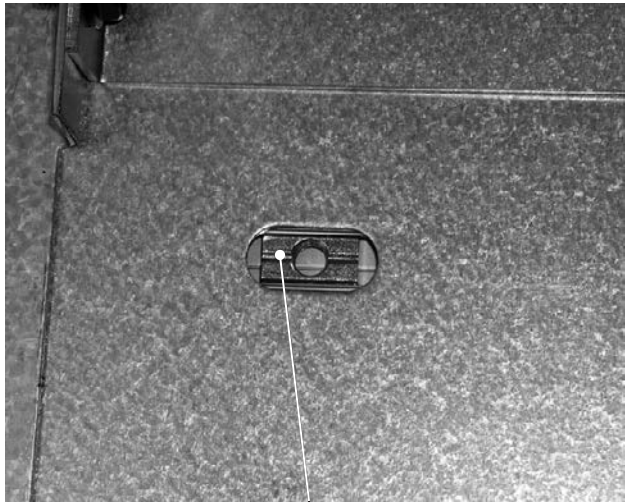

Fig. 2.3.2.2 b: Fastening the panel to the foundation frame



Slot in the foundation frame section





M 8 T-nut

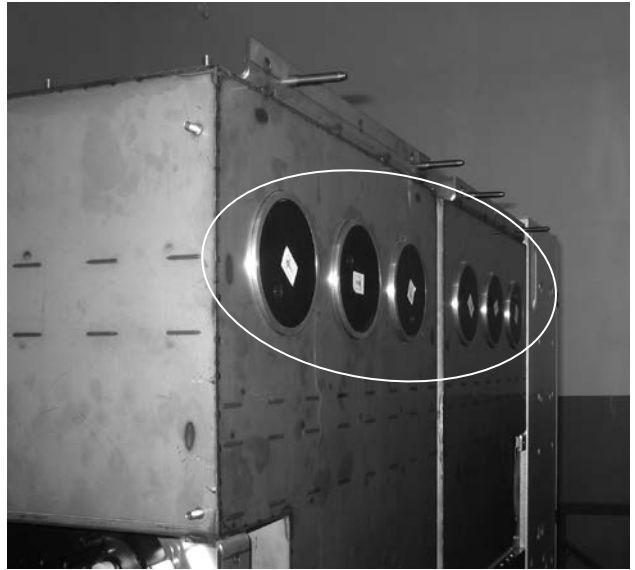

Fastening of the panel to the foundation frame

Fig. 2.3.2.3: Protective caps on the busbar sockets



 Prepare the busbar sockets, contact tubes and insulating parts for the relevant panel (clean and grease as necessary) as described in section 2.1.3. Protect the components from soiling.

- Then, carefully insert the contact tubes into the previously installed panel up to the stop, and then insert the insulating parts (figure 2.3.2.4).

 Greater force is needed to overcome the spring force of the second spiral contact inside the busbar socket (for rated busbar voltages over 2000 A, two contacts are used) and press the contact tube up to the stop in the busbar socket.

 Align the contact tubes horizontally.

- Slide the extension panel carefully against the existing system without tipping it, in such a way that the contact tubes slide into the busbar sockets and the guide pins into the corresponding bores in the fastening bracket.

Fig. 2.3.2.4: Fitted contact tubes and silicone insulating parts (the front busbar socket in the figure still has to be fitted with a silicone insulating part).

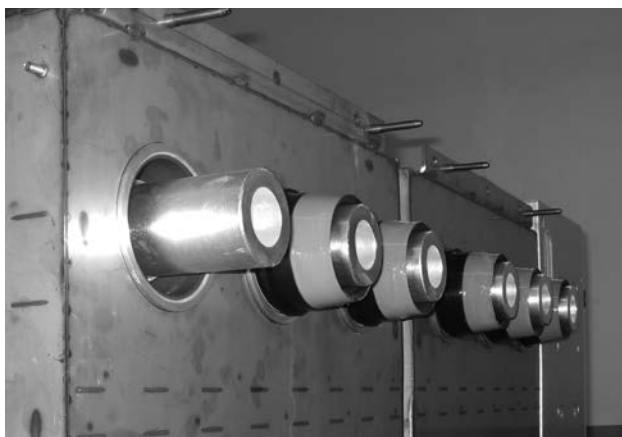

Fig. 2.3.2.5 a: Coupling of the panels

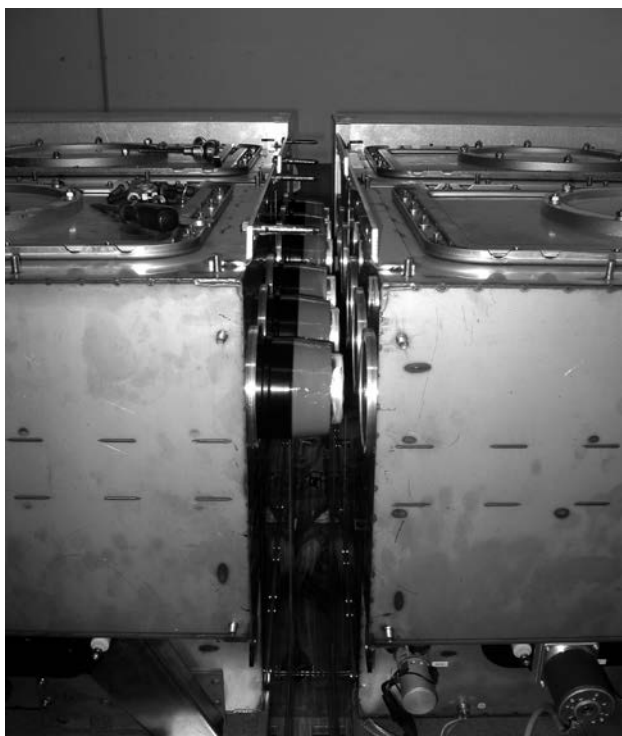



Fig. 2.3.2.5 b: Coupling of the panels



 Apply drawing or pressing tools to a large area on the panel directly above the floor (for instance by using a wooden beam between the tool and the panel) so as to avoid damage to the panel.

– As soon as the distance between the two panels is appropriately small, connect the fastening brackets of two adjacent busbar compartments with three M 10 x 50 cheese head screws (per busbar compartment), dished washers and nuts (figure 2.3.2.5). Initially, only lightly tighten the bolt connection.

– Connect the brackets on the adjacent busbar compartments with one M 8 x 40 cheese head screw, nut and washers for each connecting point. A spacer is used to bridge the distance between the two brackets (figure 2.3.2.7). In the case of the rear busbar compartment with the cover removed, the brackets are accessible from the rear, and in the case of the front busbar compartment they are accessible from the front when the low voltage compartment is open. Initially, only lightly tighten the bolt connection.

– Connect the two panels together by tightening the screws across the diagonal at the points marked in figures 2.3.2.8 - 11. Fully tighten the bolted connections shown in figures 2.3.2.6 and 2.3.2.7 across the diagonal.

– Check the alignment of the panel and fasten it to the foundation frame rails as described above.

Fig. 2.3.2.6: Bolting the panels together

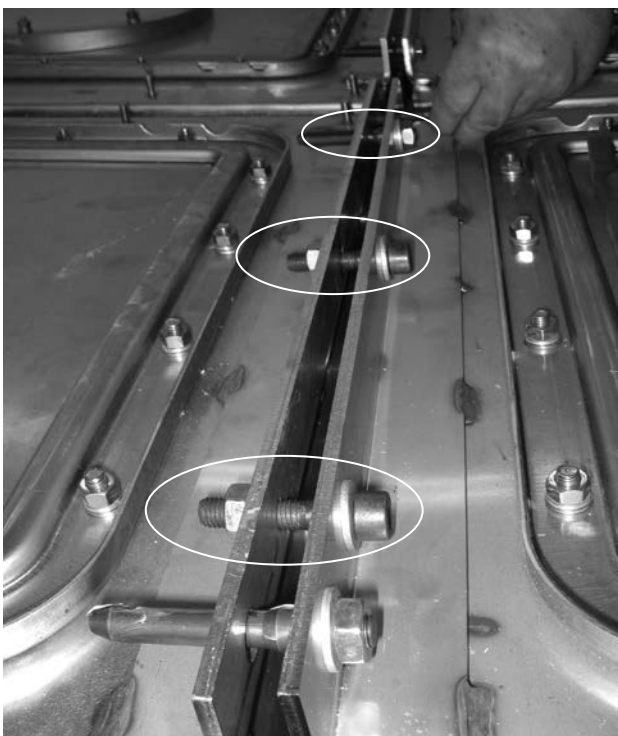

Fig. 2.3.2.7: Bolting the panels together (view of the busbar compartment from the rear)

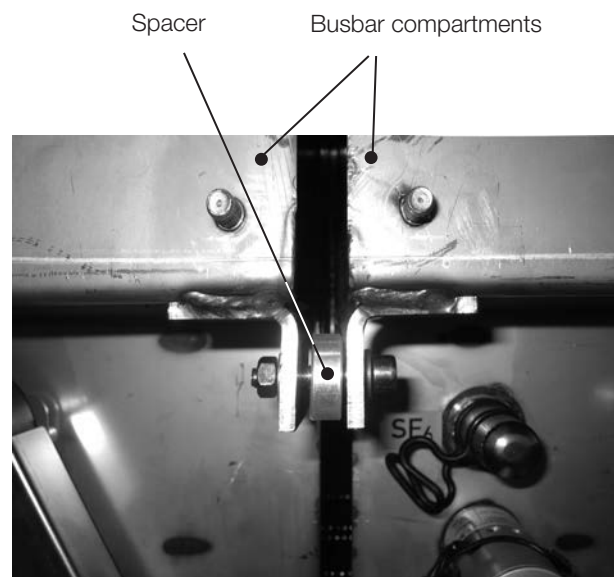

Fig. 2.3.2.8: Panel joints for double busbar panel

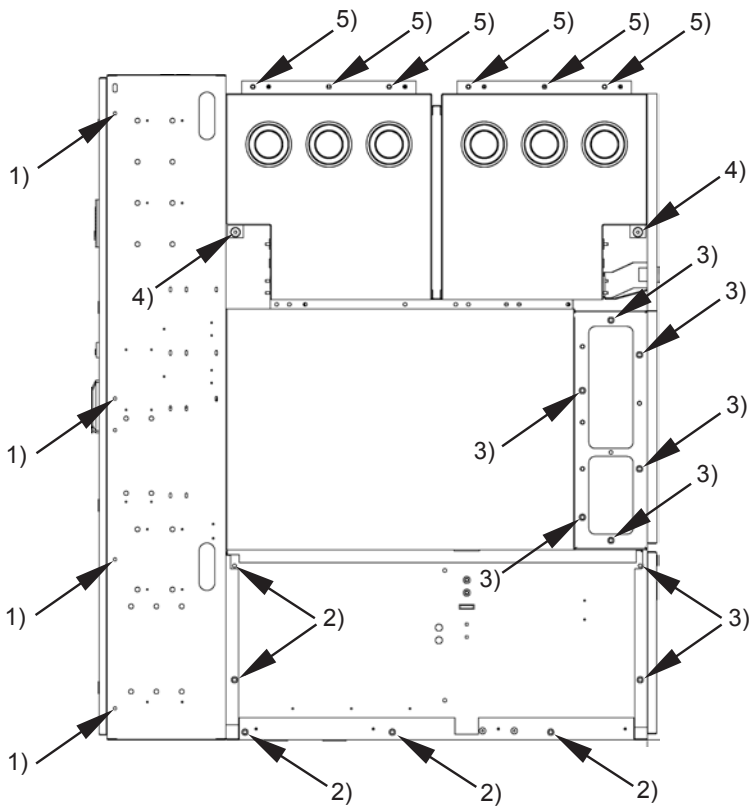
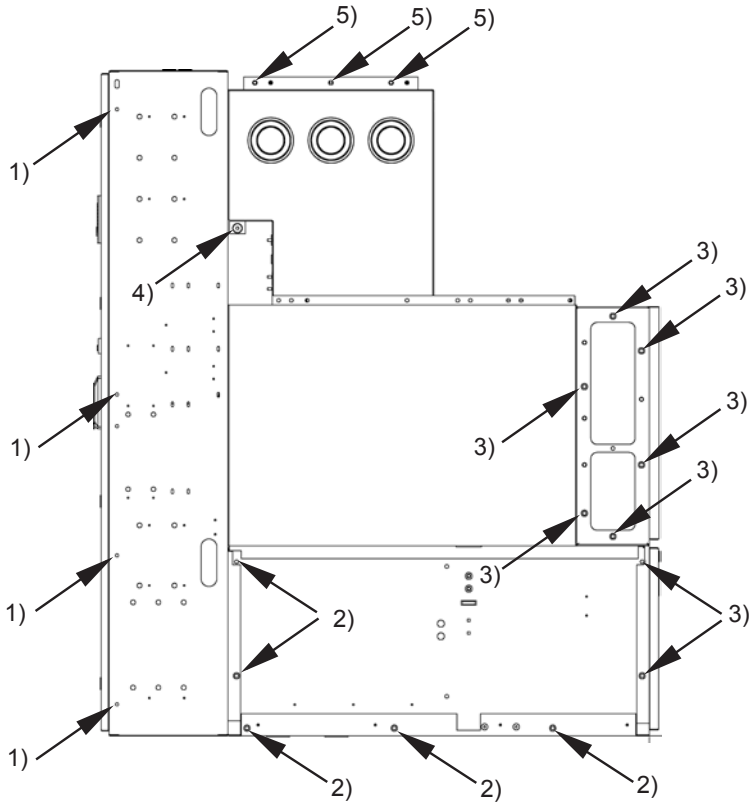

Fig. 2.3.2.9: Panel joints for single busbar panel, busbar at front



- 1) Cheese head screw, M 8 x 25
Nut, M 8
2 x dished washer, 8
- 2) Hexagon screw, M 8 x 25
Dished washer, 8
- 3) Cheese head screw, M 8 x 25
Dished washer, 8
- 4) Spacer
Cheese head screw, M 8 x 40
Nut, M 8
2 x dished washer, 8
(see figure 2.3.2.7)
- 5) Cheese head screw, M 10 x 50
Nut, M 10
2 x dished washer 10
(see figure 2.3.2.6)

Fig. 2.3.2.10: Panel joints for single busbar panel, busbar at rear

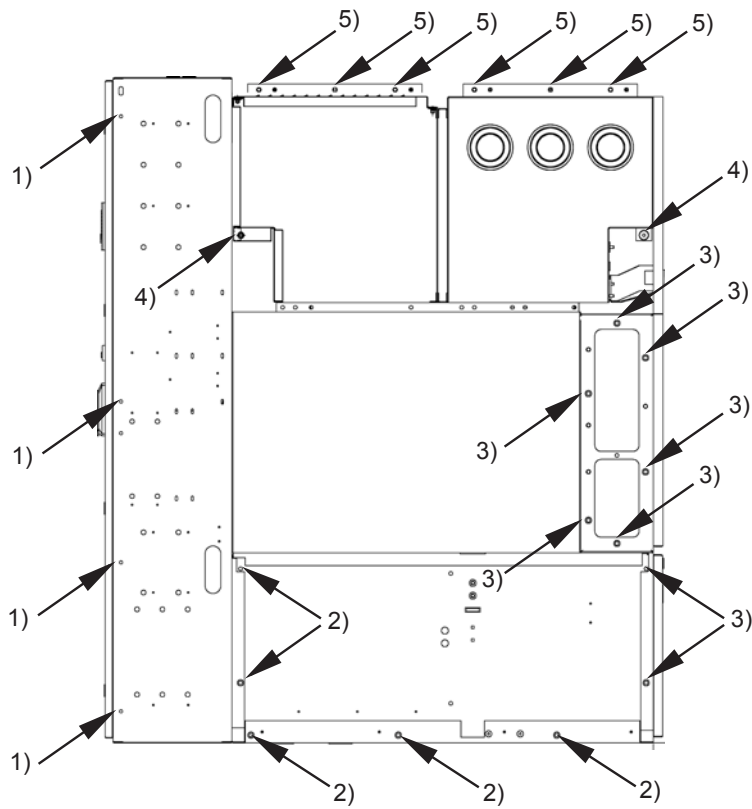
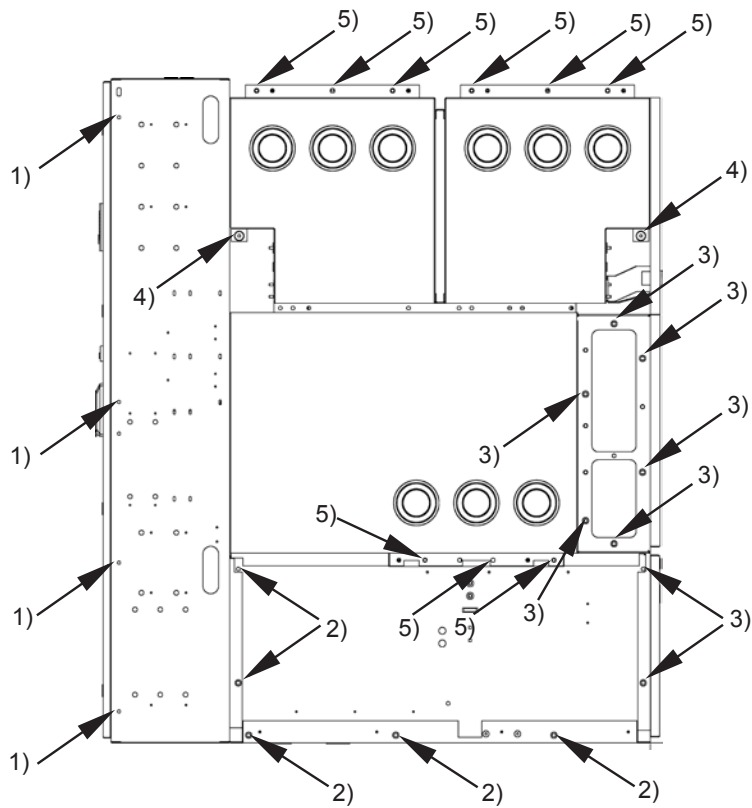

Fig. 2.3.2.11: Panel joints for sectionaliser panel with double busbar



- 1) Cheese head screw, M 8 x 25
Nut, M 8
2 x dished washer, 8
- 2) Hexagon screw, M 8 x 25
Dished washer, 8
- 3) Cheese head screw, M 8 x 25
Dished washer, 8
- 4) Spacer
Cheese head screw, M 8 x 40
Nut, M 8
2 x dished washer, 8
(see figure 2.3.2.7)
- 5) Cheese head screw, M 10 x 50
Nut, M 10
2 x dished washer 10
(see figure 2.3.2.6)

- Lead the control wiring for the panel-panel connection through the opening in the adjacent panel.
- Connect the earthing bars of the panels together (figure 2.3.2.12) by dismantling the earthing link fitted at the works for transport, guiding it through the opening to the adjacent panel and tightening the screws with the specified torque.
- Install the further panels in the manner described in section 2.3.2.

Fig. 2.3.2.12: Assembling the earthing bar link

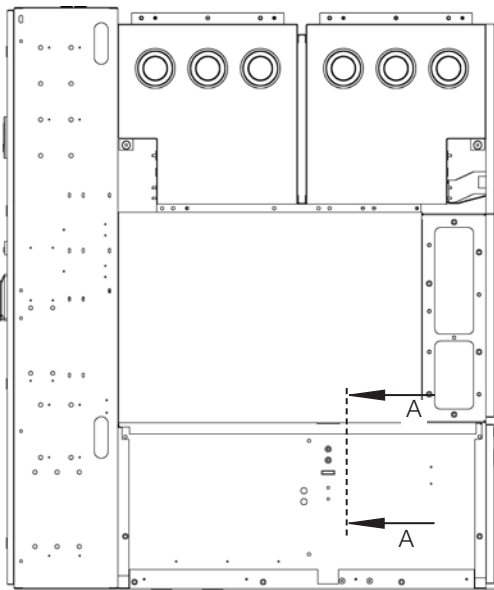

Section A-A

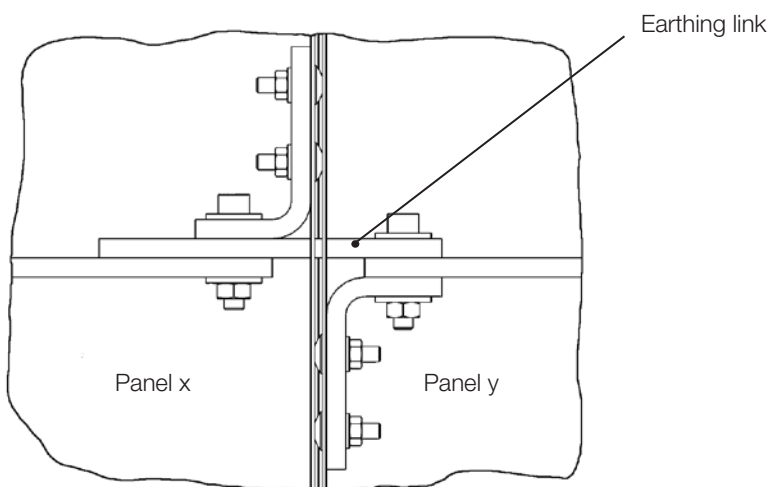

2.3.3 Closure of extendable busbar sockets

On the outer sides of the end panels, extendable busbar sockets are as a rule fitted with insulating blanking plugs at the works. This can be seen from the pressure plates mounted at the sides of the busbar compartments of the extendable panels (figure 2.3.3.1). The pressure plates are used to fasten the insulating blanking plugs in place.



If extendable busbar sockets at the ends of the end panels are not closed off with insulating blanking plugs, the blanking plugs must be fitted at site in accordance with section 2.1.3 and with the aid of the assembly drawings provided.

Operation of the switchgear with open busbar sockets (including those in the course of the busbars, e.g. in sectionaliser panels, etc.) is not permissible!

Fig. 2.3.3.1: Blanking plugs for busbar sockets

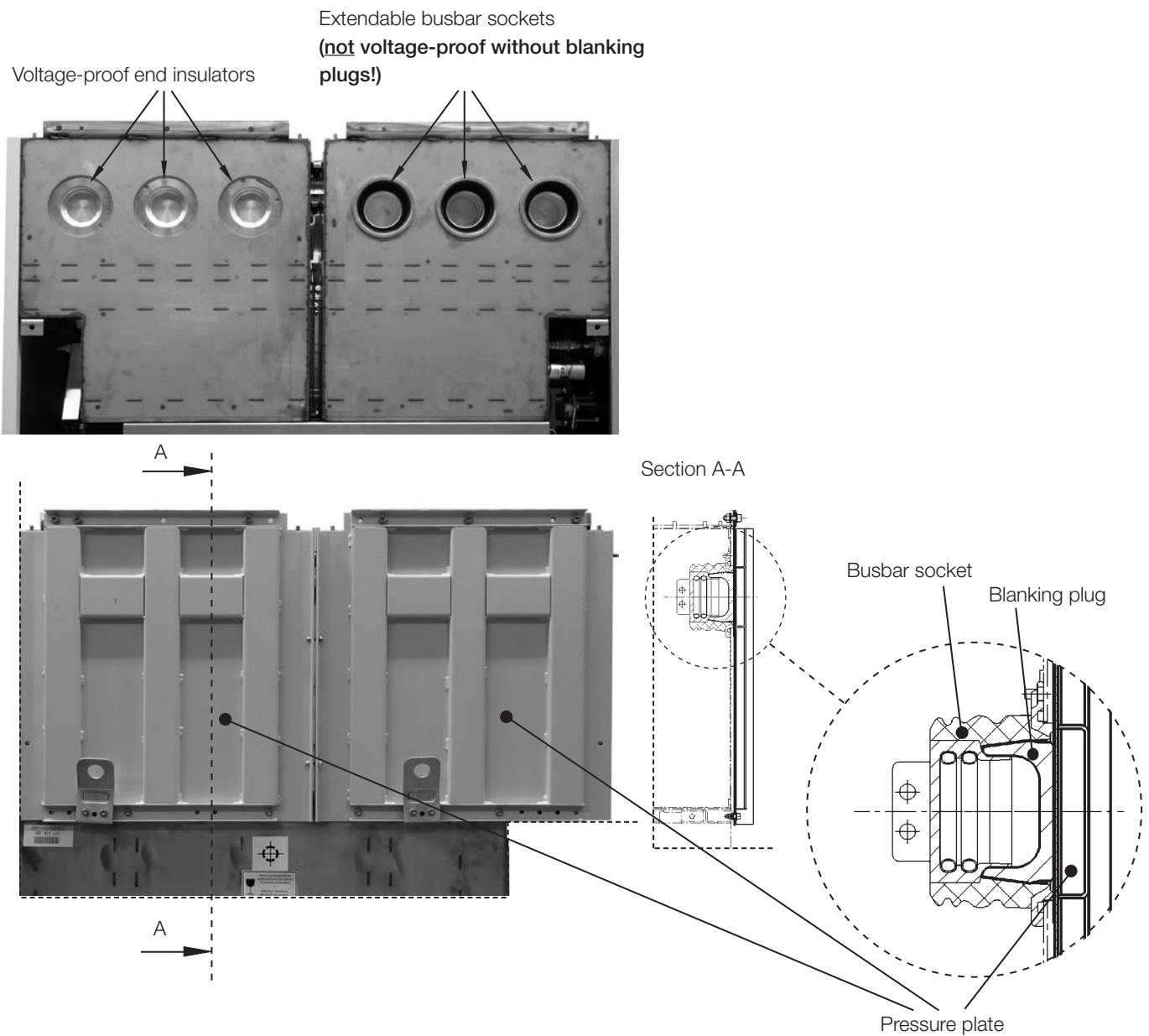

2.3.4 Installation of the heat sinks

Heat sinks fitted on the busbar compartment for rated currents > 2000 A are as a rule supplied separately and installed after the panels have been set up.

The relevant busbar compartments are filled with N₂ (nitrogen) for transport. (With regard to the gas work required, consult instruction manual HB 605 E – use of SF₆ insulating gas).



The weight of a heat sink is approx. 90 kg. Use suitable lifting gear (e.g. a mobile gantry crane) to assemble the heat sinks. We recommend having installation performed by two fitters. Observe the relevant accident prevention regulations in the country of installation.

Assembly (see fig. 2.3.4.1):



Follow the installation drawings supplied when fitting the heat sinks.

Assembly must take place in as clean (dust-free) conditions as possible.

- Release the gas (N₂) from the relevant busbar compartment into the atmosphere by pressing the valve pin (see HB 605 E) until the pressure is equalised.
- Dismantle the transport lid on the heat sink and the pressure relief lid on the busbar compartment.
- Remove the transport drying agent bags from the gas compartments and replace them with new bags with the same quantity of drying agent. Continue assembly immediately, so as not to impair the effectiveness of the drying agent material.
- Clean the sealing surfaces of the busbar compartment, the heat sink and the sealing ring with a dry, clean, non-fraying cloth.



Thinly grease the entire surface of the sealing ring with silicone paste.

- Set the sealing ring on the roof plate of the busbar compartment and align it symmetrically to the opening. Use suitable lifting gear to set the heat sink on the busbar compartment in such a way that the relevant studbolts in the busbar enclosure engage in the bores in the flange plate on the heat sink, taking care to ensure that the sealing ring is correctly positioned in the slot of the heat sink flange.

Fig. 2.3.4.1: Installation of the heat sinks

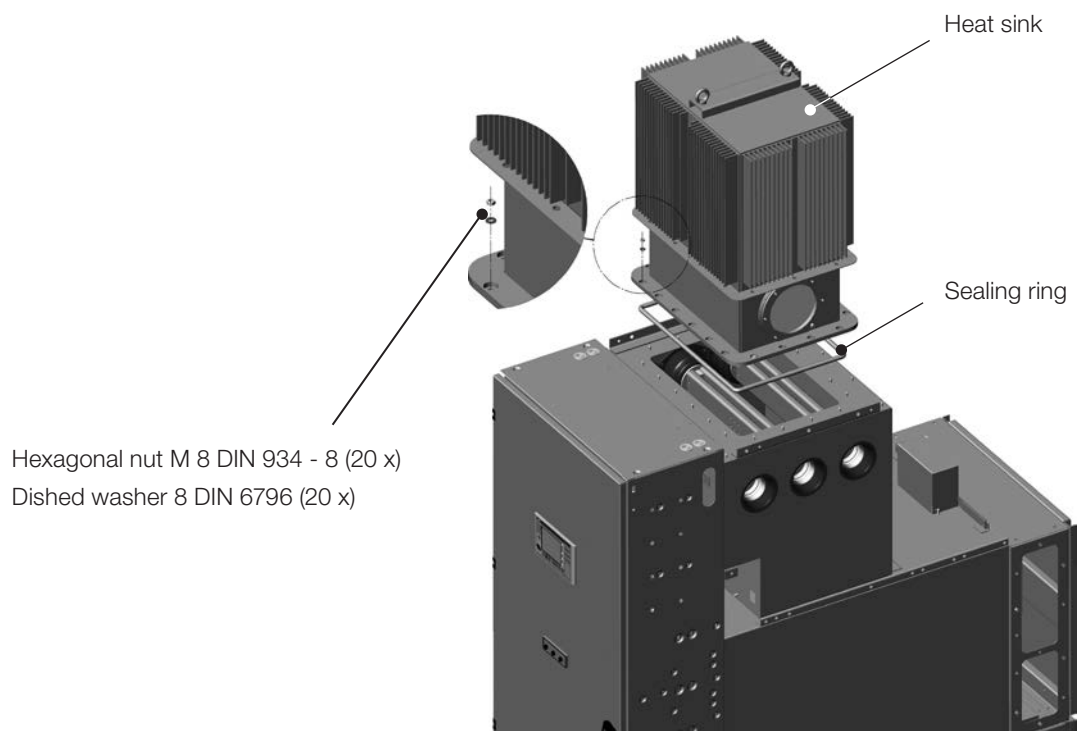

- Align the bores in the flange plate so that they are centred around the studbolts.
- Fasten the heat sink across the diagonal at all studbolts, using washers, spring washers and nuts, with a torque of 12.5 Nm (for unlubricated studbolts).
- Evacuate and fill the gas compartment (busbar compartment + heat sink) with SF₆ as described in manual HB 605. Check the gas compartment for leakage.

2.3.5 Installation of the top-mounted box for the busbar metering system with isolating device

Top-mounted boxes for busbar metering systems with isolating devices are generally delivered separately and have to be installed after the panels have been set up.

The relevant busbar compartments are filled with N₂ (nitrogen) for transport. (With regard to the necessary gas work, see manual HB 605 – Use of SF₆ insulating gas.)



A top-mounted box weighs approx. 105 kg. Use suitable lifting gear (e.g. a mobile gantry crane) to install the top-mounted box. We recommend having two fitters perform the installation work. Please observe the accident prevention regulations in the country of installation.

Installation of the top-mounted box on the front busbar compartment is described below. The procedure is similar for Installation of the top-mounted box on the rear busbar compartment.

Installation of the top-mounted box (see fig. 2.3.5.1):



Observe the installation drawings supplied when installing the top-mounted boxes

Installation must take place in a dry place with as little dust as possible.

- Press in the valve pin (see HB 605) to release the gas (N₂) in the relevant busbar compartment and top-mounted box into the atmosphere.
- Remove the transport lids from the adapter box and the top-mounted box. The reinforcement strips to be removed in that process are required later for installation of the top-mounted box.
- Remove the side assembly cover from the top-mounted box.
- Remove all transport drying agent bags from the gas compartments and replace them with new drying agent bags with the same quantities. Continue installation immediately so as not to reduce the effectiveness of the drying agent.
- Clean the sealing surfaces of the adapter box and the top-mounted box and the sealing ring with a dry, clean and non-fraying cloth.



Thinly grease the entire surface of the sealing ring with silicone paste.

- Lay the sealing ring in the slot on the adapter box. Use a suitable hoist to position the top-mounted box on the adapter box in such a way that the relevant welded studbolts on the top-mounted box engage in the bores in the flange plate of the adapter box, ensuring that the sealing ring is correctly positioned in the slot on the adapter box.



To strengthen the flange, position the reinforcement strips (4 pcs., see fig. 2.3.5.1, bottom) before fitting the washers, spring washers and nuts to the studbolts. Tighten the nuts across the diagonal with a torque of 12.5 Nm (studbolts ungreased).

Fig. 2.3.5.1: Installation of the top-mounted box

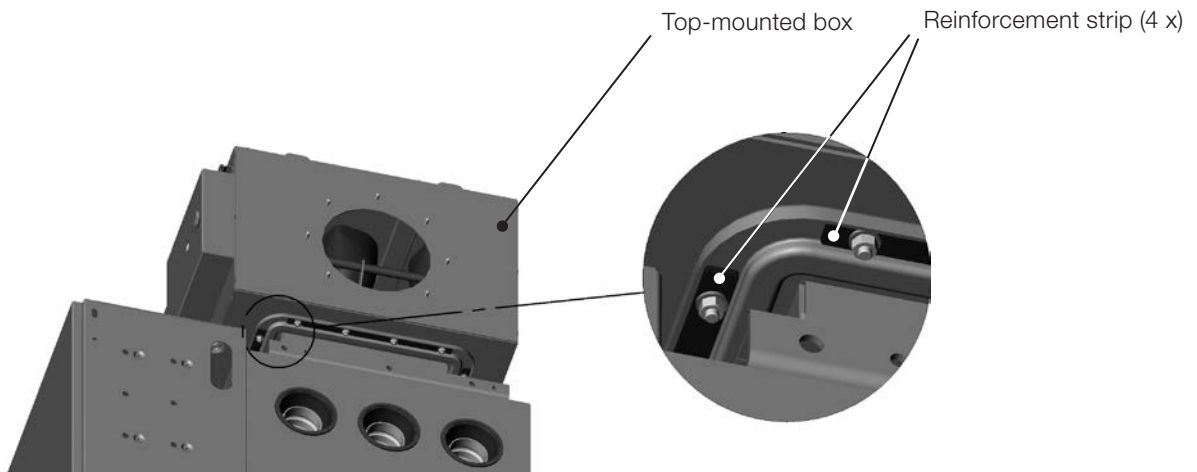
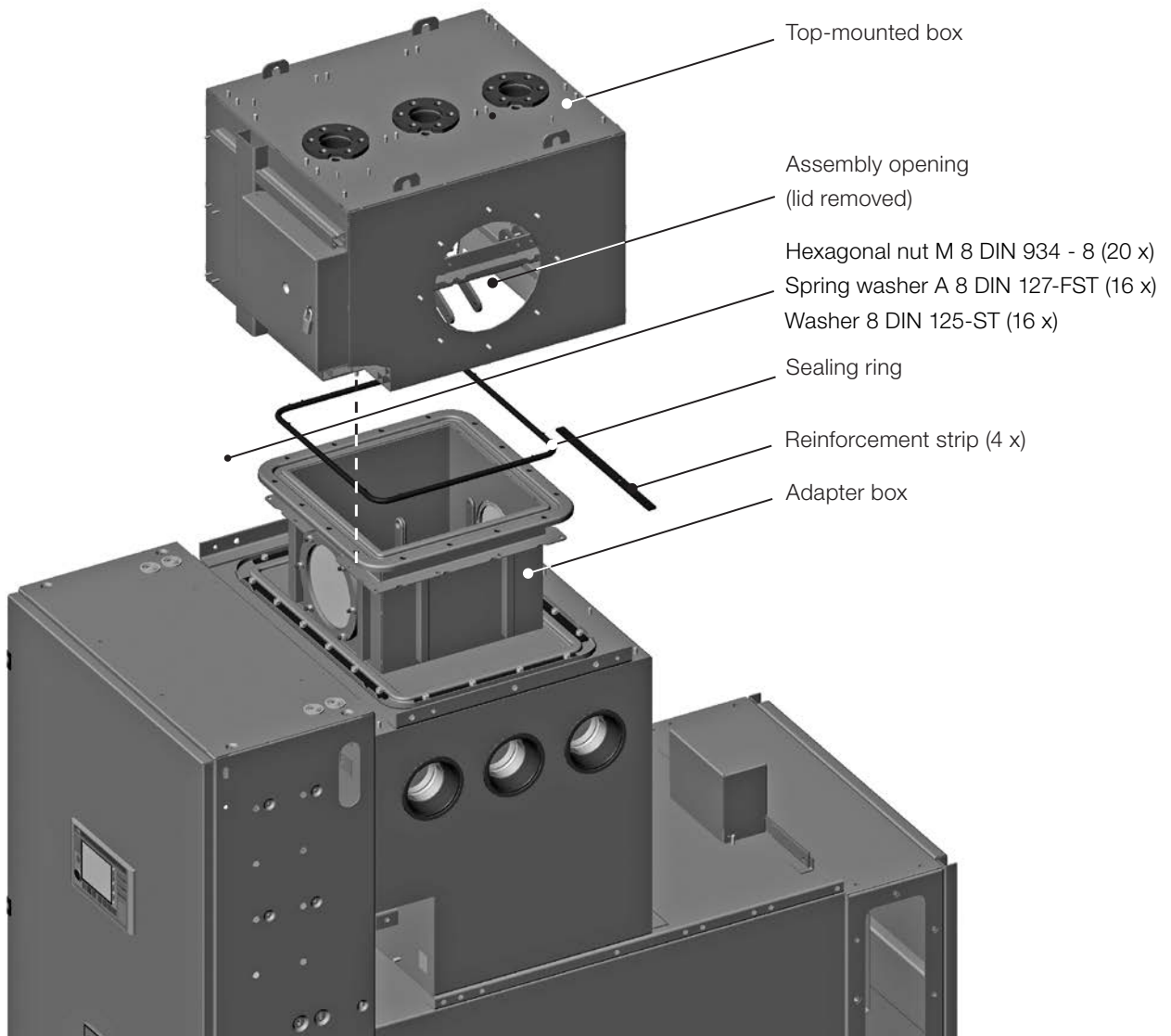

Installation of the connecting conductors (see fig. 2.3.5.2):

- The upper flat conductors for connection of the voltage transformer sockets are fixed in a transport position at the works. Release the upper fastening screws (1) on the flat conductors so far that the flat conductors can be easily turned around the fastening screws (the screws remain in position). Turn the flat conductors so that their lower bores are aligned with the bores of the flat conductors in the adapter box.
- Connect the upper flat conductors to the flat conductors in the adapter box using countersunk screws (!), dished washers and nuts.



The correct position of the flat conductors is important for their function! See fig. 2.3.5.2 for the correct position of the flat conductors.

- Tighten the relevant screws, applying the specified torque.
- Clean the sealing ring for the side assembly cover on the top-mounted box, the slot in the assembly cover and the sealing surface for the o-ring on the top-mounted box.



Thinly grease the entire surface of the sealing ring with silicone paste.

- Lay the sealing ring in the slot of the assembly cover. Move the cover into the installation position and tighten the fastening nuts across the diagonal with the specified torque.
- Evacuate and fill the gas compartment (busbar compartment, adapter box and top-mounted box) with SF₆ as described in manual HB 605. Use the filler valves on the busbar compartments. Check the gas compartment for leakage.
- The instructions for installing the voltage transformers can be found in the section entitled “Handling of voltage transformers”.

Fig. 2.3.5.2: Installation of the connecting conductors (simplified)

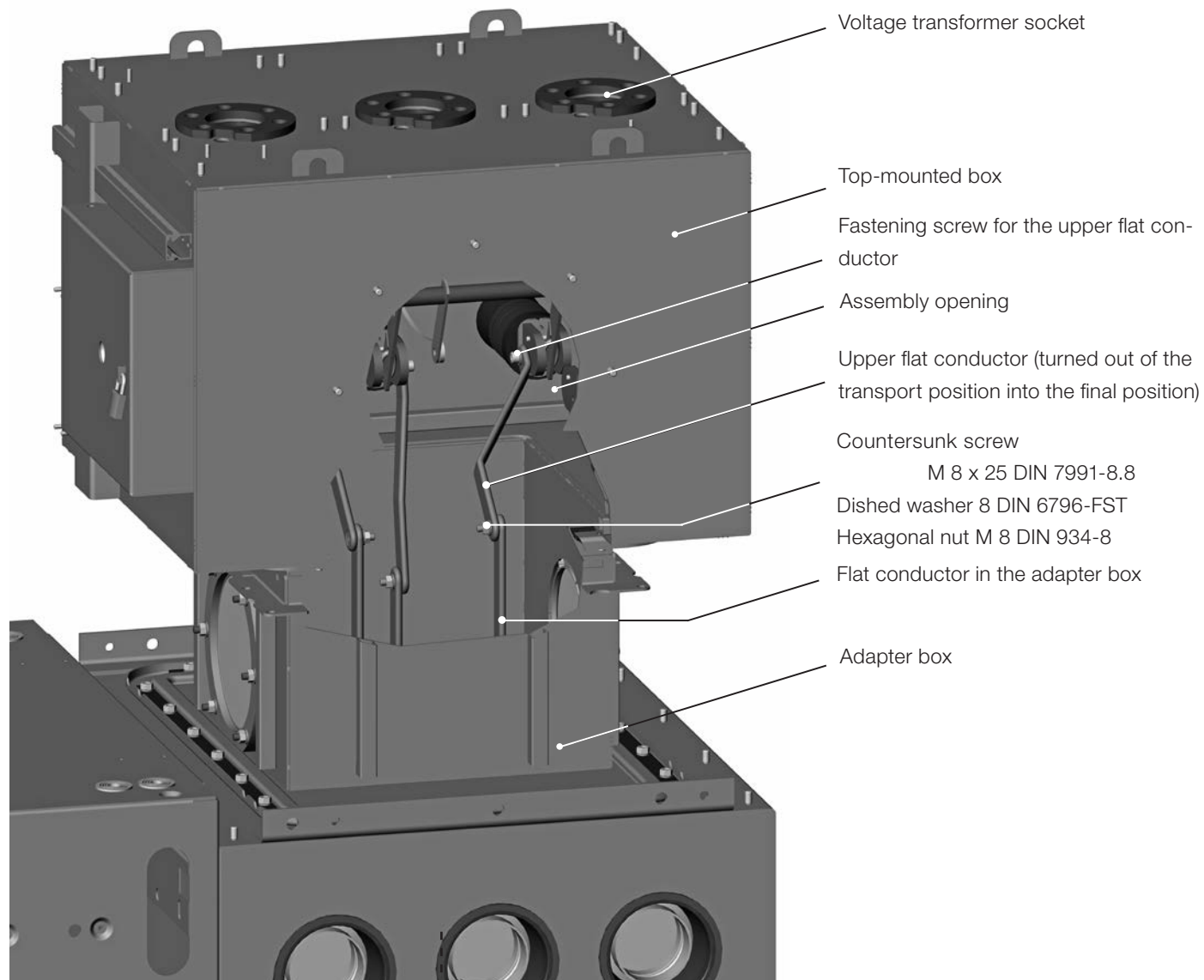

2.3.6 Installation of the pressure relief ducts and end covers

The pressure relief ducts and the end covers are to be installed in accordance with the assembly drawings supplied with the panels.

2.3.7 Handling of voltage transformers

As a rule, voltage transformers for feeder measurement (transformers of metering 1 and 2 in figure 2.3.7.1) are supplied fitted and ready for operation. These voltage transformers must be dismantled prior to installation of the cables and re-installed after high voltage testing of the switchgear system.

Voltage transformers for integrated busbar measurement (transformers of metering 3 and 4 in figure 2.3.7.1) are supplied loose and have to be installed at site after high voltage testing.

As a rule voltage transformers in panels with outer cones (metering 5) are installed ex-works. In individual cases, voltage transformers may also be supplied loose. Please contact ABB for installation information. Wire the transformers after installation according to chapter 2.3.7.8.



The weight of a voltage transformer can be over 30 kg. Use suitable lifting gear (e.g. a mobile gantry crane) to install the voltage transformers for integrated busbar measurement (type 3 and 4). We recommend having installation performed by two fitters. Observe the relevant accident prevention regulations in the country of installation.

Fig. 2.3.7.1: Installation positions of voltage transformers

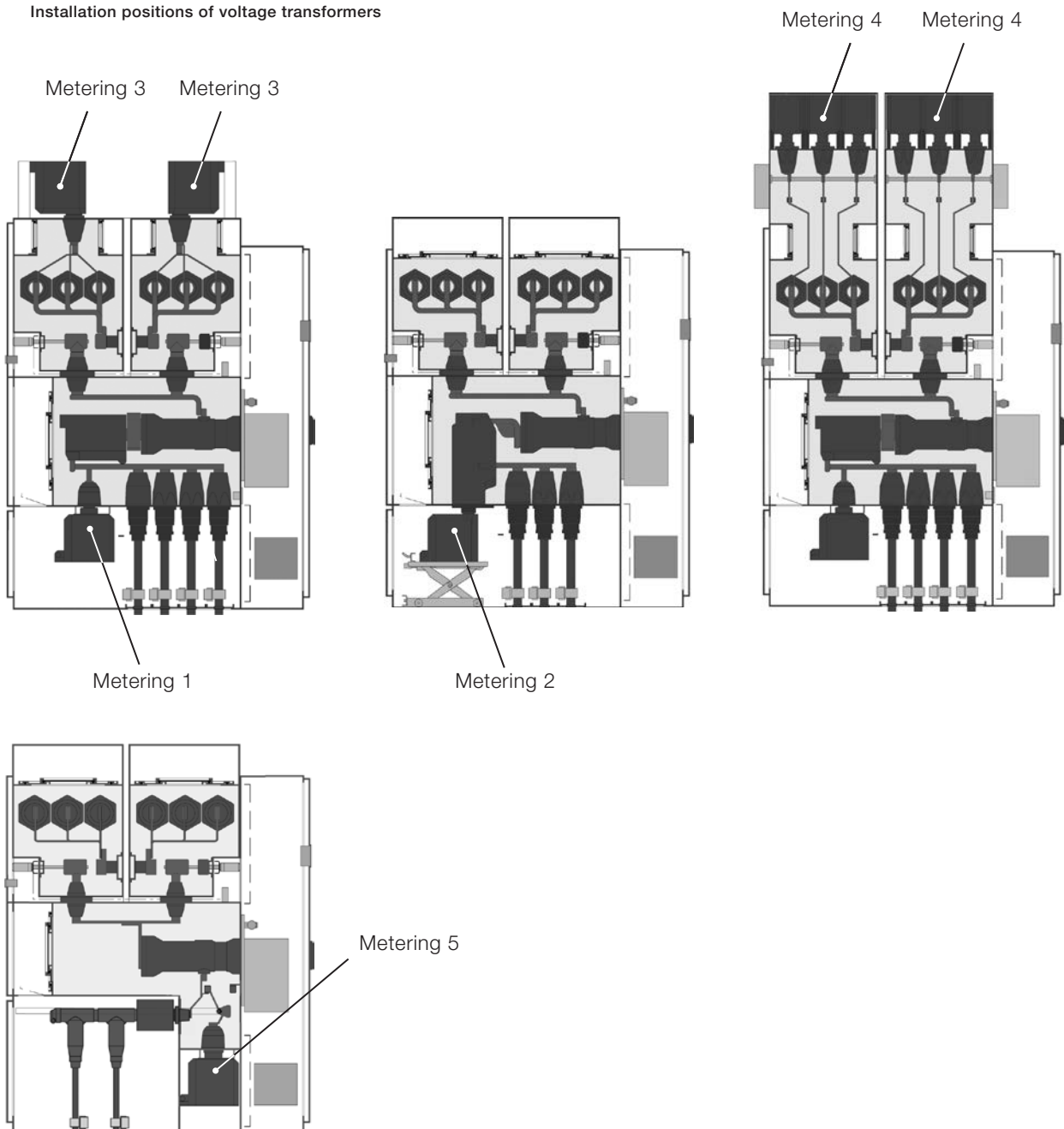

2.3.7.1 Dismantling of voltage transformers (metering 1)



If the switchgear is in operation:

- Isolate the relevant outgoing feeder panel before dismantling the voltage transformers.
- Comply with the safety regulations of EN 50110.
- Test the feeder panel for the off-circuit condition in accordance with section 5.1.
- Earth the feeder panel and secure the working area in accordance with section 4 and EN 50110 standard.
- Switch the mcbs ¹⁾ for the relevant operating mechanisms off so that the feeder panel cannot be switched on by remote control.

- Remove the cover from the cable termination compartment.
- Dismantle the lower crossbeam in the cable termination compartment by removing the screws marked in figure 2.3.7.1.1.
- Disconnect the plugs for the secondary wiring of the voltage transformers.
- Remove the padlock (figure 2.3.7.1.2), slide the retaining plate to the right and also remove it. Store the parts for further use.



Only disengage the locking knob (figure 2.3.7.1.3) when the relevant voltage transformer is supported by the assembly aid as described below.

- Start dismantling with the middle voltage transformer. Insert the assembly aid into the cable termination compartment up to the stop. Allow the assembly aid to engage with the stop.

Fig. 2.3.7.1.1: View from the rear into the cable termination compartment with the cover removed: position of the fastening screws for the lower crossbeam



Fig. 2.3.7.1.2: Installation position of the voltage transformers secured by retaining plate and padlock

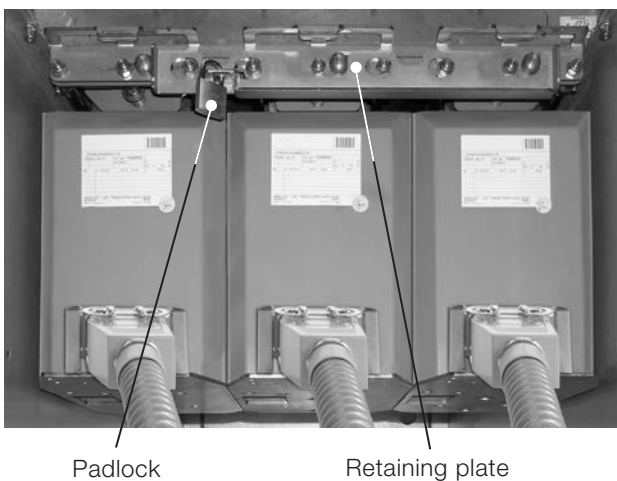
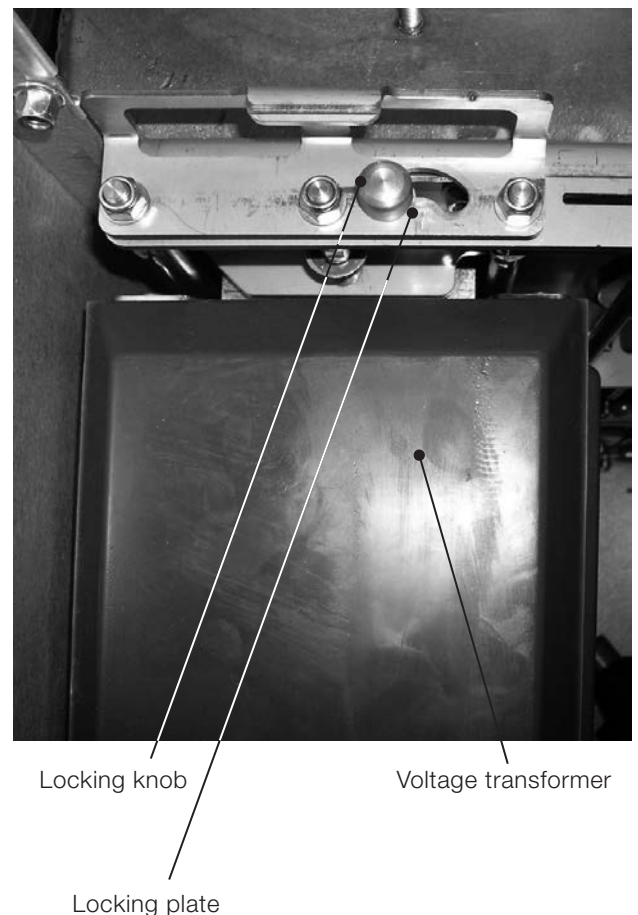

Fig. 2.3.7.1.3: Locking knob and locking plate



¹⁾ mcb: miniature circuit breaker

- Crank the assembly aid up to the stop (= baseplate of the voltage transformer), ensuring that the centring washers in the assembly aid are in line with the bores in the base plate of the voltage transformer.
- Disengage the locking plate by sliding the locking knob to the right (figure 2.3.7.1.3). The locking plate is pressed outwards by approx. 2 cm, thus releasing the voltage transformer.

Fig. 2.3.7.1.4: Crank for assembly aid

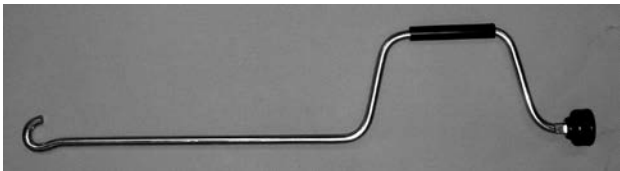

Fig. 2.3.7.1.5: Assembly aid in the cable termination compartment beneath a voltage transformer

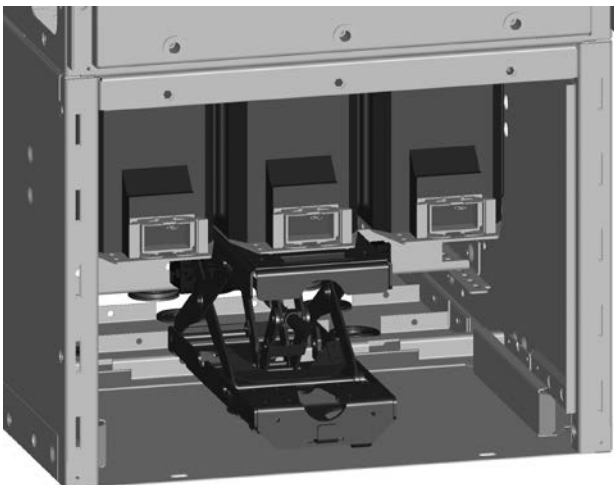
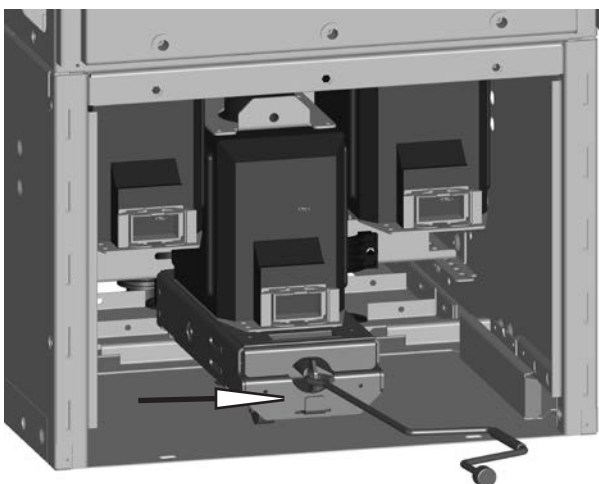

Fig. 2.3.7.1.6: Disengaging the assembly aid



- Crank the voltage transformer down until the stop is reached. (Fig. 2.3.7.1.6).
- Disengage the assembly aid (figure 2.3.7.1.6) and roll the assembly aid with voltage transformer out of the panel.
- Lift the voltage transformer off the assembly aid using the lifting handle (figure 2.3.7.1.7).
- Dismantle the further voltage transformers in the same way.
- Fit the protective caps supplied to protect the silicone insulating parts of the voltage transformers from soiling and damage.
- Close off the open voltage transformer sockets with insulating blanking plugs prior to bringing the panel on line or performing high voltage testing.
- Refit the lower crossbeam in the cable termination compartment (figure 2.3.7.1.1).
- Hang the cover of the cable termination compartment in position and screw the cover tight.

Fig. 2.3.7.1.7: Voltage transformer with lifting handle



Lifting handle

2.3.7.2 Installation of voltage transformers (metering 1)



If the switchgear is in operation:

- Isolate the relevant outgoing feeder panel before installing the voltage transformers.
- Comply with the safety regulations of EN 50110.
- Test the feeder panel for the off-circuit condition in accordance with section 5.1.
- Earth the feeder panel and secure the working area in accordance with section 4 and EN 50110 standard.
- Switch the mcbs ¹⁾ for the relevant operating mechanisms off so that the feeder panel cannot be switched on by remote control.

- Remove the cover from the cable termination compartment.
- Dismantle the lower crossbeam in the cable termination compartment by removing the screws marked in figure 2.3.7.1.1.
- Remove the padlock from the retaining plate (figure 2.3.7.1.2) and slide the retaining plate to the right. Remove the retaining plate and store the parts for further use.
- Unblock the locking knobs (2.3.7.1.3) for the three phases one after another (= slide them to the right). The locking plates (5.6) are pressed outwards by approx. 2 cm in that process.
- First install the two outer voltage transformers and then the middle voltage transformer as described below.
- Remove the protective caps from the silicone parts of the voltage transformers and store them for further use.



Check the silicone part of the voltage transformer for damage. Observe the notes in section 2.1.3.



Clean and grease the silicone insulating part of the voltage transformer as described in section 2.1.3.

- Remove the dust protection cap or blanking plug from the voltage transformer socket and store the components for further use.



Earth the threaded bores in the voltage transformer sockets by fitting them with countersunk screws, DIN 7991, M8 x 30 (unless already fitted). (Figure 2.3.7.2.1).



Clean the voltage transformer socket as described in section 2.1.3.

Fig. 2.3.7.2.1: Socket for voltage transformer: earthing the threaded bores (arrows) with countersunk screws, DIN 7991, M8 x 30



- Position the assembly aid in front of the cable termination compartment. Place the voltage transformer on the assembly aid using the transport shackle (a correct position is obtained with the aid of two centring washers on the assembly aid and bores in the base plate of the voltage transformer).
- Roll the assembly aid bearing the voltage transformer into the intended position below the voltage transformer sockets in the cable termination compartment and engage it with the stop.

¹⁾ mcb: miniature circuit breaker

- First crank the voltage transformer up by a few centimeters only and ensure that the silicone insulating part of the voltage transformer can be inserted into the socket without obstruction. Crank the voltage transformer up until the bore in the retaining plate of the transformer is aligned with the locking pin (figure 2.3.7.2.2). This is the case when the locking plate can be pressed into the locking position.
 - When the locking plate has been pressed into the locking position, slide the locking knob to the left into its limit position (figure 2.3.7.2.2). The voltage transformer is then fixed in the correct position.
 - Lower the voltage transformer truck by turning the crank until the stop is reached.
 - Disengage the assembly aid (figure 2.3.7.1.5) and remove it from the cable termination compartment.
 - Wipe any surplus grease off from the area of the voltage transformer flange below the voltage transformer's plug-in connection as far as possible.
 - Install the further voltage transformers in the same way.
 - Fit the retaining plate and secure it with the padlock (figure 2.3.7.1.2).
 - Insert the secondary side plugs into the sockets provided on the voltage transformers. Lock the plugs in place with the integrated clamps.
-  Ensure that the plugs are correctly assigned to the relevant voltage transformers.
- Refit the lower crossbar in the cable termination compartment. (figure 2.3.7.1.1).
 - Fit and screw in the cover of the cable termination compartment.

Fig. 2.3.7.2.2: Cranking the voltage transformer up until the locking pin is aligned with the bore



2.3.7.3 Dismantling of voltage transformers (metering 2)

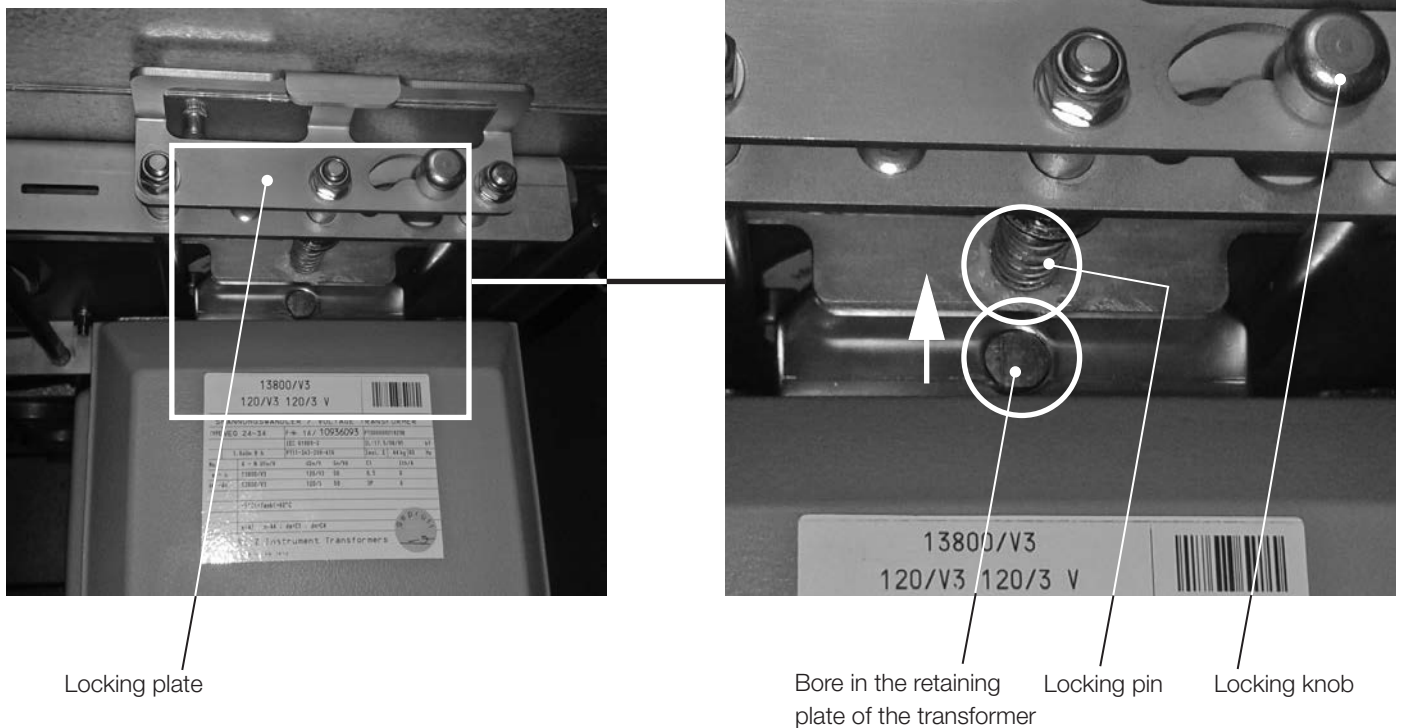

If the switchgear is in operation:

- Isolate the relevant outgoing feeder panel before dismantling the voltage transformers.
- Comply with the safety regulations of EN 50110.
- Test the feeder panel for the off-circuit condition in accordance with section 5.1.
- Earth the feeder panel and secure the working area in accordance with section 4 and EN 50110 standard.
- Switch the mcbs ¹⁾ for the relevant operating mechanisms off so that the feeder panel cannot be switched on by remote control.

- Remove the cover from the cable termination compartment.
- Dismantle the side covers on the cable termination compartment by releasing the screws marked in figure 2.3.7.3.1.

Fig. 2.3.7.3.1: Dismantling the side covers on the cable termination compartment (the figure shows the right-hand cover only)

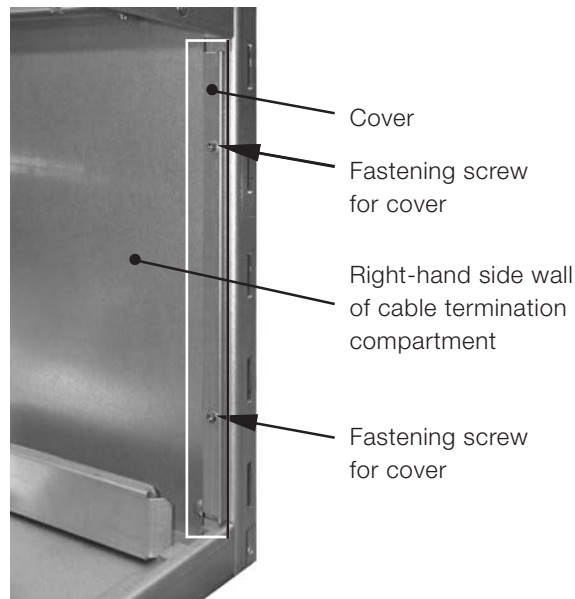

¹⁾ mcb: miniature circuit breaker

- Dismantle the lower crossbeam in the cable termination compartment by removing the screws marked in figure 2.3.7.1.1.
- Disconnect the plugs for the secondary wiring of the voltage transformers.
- Release the locking screw on the spindle (figure 2.3.7.3.2).
- Lower the voltage transformer truck by turning the spindle until the stop is reached (see figure 2.3.7.3.3 for crank).
- Remove the crank from the cable termination compartment.
- Draw the voltage transformer truck out of the panel by its handles.
- Cover the silicone insulating parts of the voltage transformers with the protective caps supplied to protect them from soiling and damage.
- Close off the open voltage transformer sockets with insulating blanking plugs prior to bringing the panel on line or performing high voltage testing.
- Refit the lower crossbar in the cable termination compartment. (figure 2.3.7.1.1).
- Refit the side covers on the cable termination compartment (figure 2.3.7.3.1).
- Fit and screw in the cover of the cable termination compartment.

Fig. 2.3.7.3.2: Voltage transformer type 2 – Locking screw for voltage transformer truck

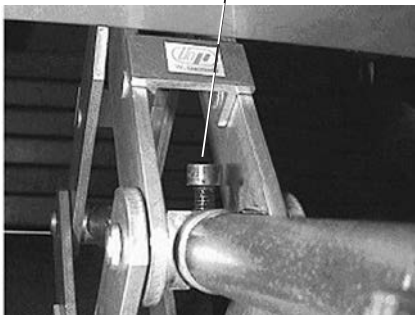
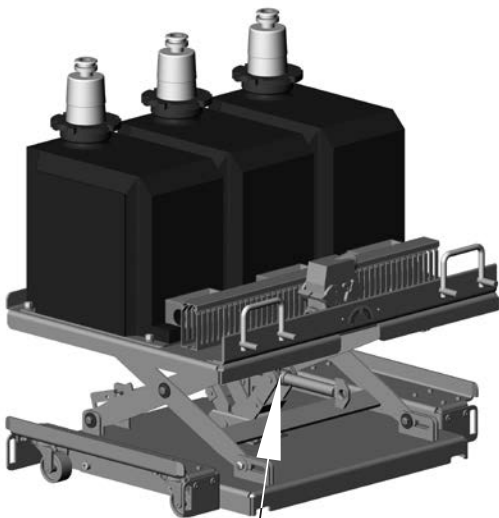
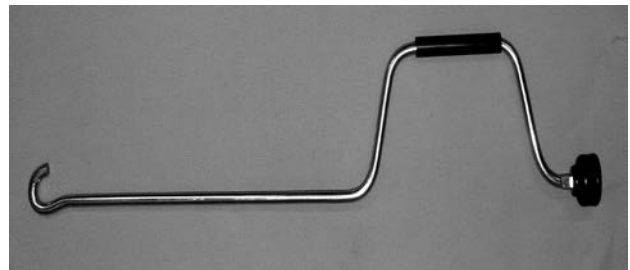





Fig. 2.3.7.3.3: Crank for the jacking system of the voltage transformer truck



2.3.7.4 Installation of voltage transformers (metering 2)



If the switchgear is in operation:

- Isolate the relevant outgoing feeder panel before installing the voltage transformers.
 - Comply with the safety regulations of EN 50110.
 - Test the feeder panel for the off-circuit condition in accordance with section 5.1.
 - Earth the feeder panel and secure the working area in accordance with section 4 and EN 50110 standard.
 - Switch the mcbs ¹⁾ for the relevant operating mechanisms off so that the feeder panel cannot be switched on by remote control.
-
- Remove the cover from the cable termination compartment.
 - Dismantle the side covers on the cable termination compartment by releasing the screws marked in figure 2.3.7.3.1.
 - Dismantle the lower crossbeam in the cable termination compartment by removing the screws marked in figure 2.3.7.1.1.
 - Remove the protective caps from the silicone parts of the voltage transformers and store them for further use.
-  Check the silicone part of the voltage transformer for damage. Observe the notes in section 2.1.3.
-  Clean and grease the silicone insulating part of the voltage transformer as described in section 2.1.3.
- Remove the protective caps from the silicone parts of the voltage transformers and store them for further use.
-  Earth the threaded bores in the voltage transformer sockets by fitting them with countersunk screws, DIN 7991, M 8 x 30 (unless already fitted). (Figure 2.3.7.2.1).
-  Clean the voltage transformer socket as described in section 2.1.3.
- Check whether the voltage transformer truck is completely lowered. This can be seen from the raised locking mechanism at the rear of the voltage transformer truck (figure 2.3.7.4.1).

- Prepare the insertion area for the voltage transformer truck into the cable termination compartment of the panel by provisionally fastening any secondary wiring to the side wall of the cable termination compartment.
- Insert the voltage transformer truck into the cable termination compartment until the rear stop is reached.
- Fit the hand crank and crank the truck upwards with 4 to 5 clockwise turns until the interlock engages.
- Check the position of the silicone parts relative to the sockets and correct if necessary.
- Carefully crank the truck upwards until the silicone parts are cleanly inserted in the sockets.
- Continue cranking until the mechanical stop (lock nut on the spindle) is reached. When raising the voltage transformer truck, forces are exerted on the floor of the cable termination compartment.
- Remove the hand crank.
- Tighten the locking screw (figure 2.3.7.3.1).
- Wipe any surplus grease off from the area of the voltage transformer flange below the voltage transformer's plug-in connection as far as possible.
- Insert the secondary side plugs into the sockets provided on the voltage transformers. Lock the plugs in place with the integrated clamps.
- Refit the lower crossbar in the cable termination compartment (figure 2.3.7.1.1).
- Refit the side covers on the cable termination compartment (figure 2.3.7.3.1).
- Fit and screw in the cover of the cable termination compartment.

Fig. 2.3.7.4.1: Rear of the voltage transformer truck: locking mechanism

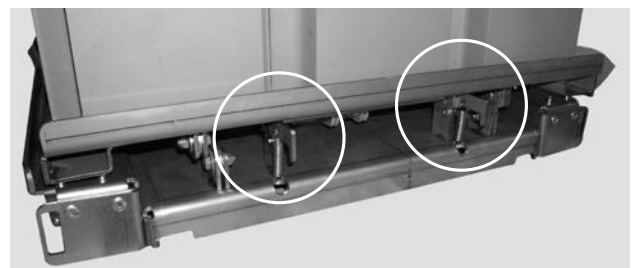

¹⁾ mcb: miniature circuit breaker

2.3.7.5 Installation of voltage transformers (metering 3)



If the switchgear is in operation:

- Isolate the relevant switchgear section before installing the voltage transformers.
- Comply with the safety regulations of EN 50110.
- Test the switchgear section for the off-circuit condition in accordance with section 5.1.
- Earth switchgear section and secure the working area in accordance with section 4 and EN 50110 standard.
- Switch the mcbs ¹⁾ for the relevant operating mechanisms off so that the switchgear section cannot be switched on by remote control.

- Remove the protective caps from the silicone parts of the voltage transformers and store them for further use.



Check the silicone part of the voltage transformer for damage. Observe the notes in section 2.1.3.



Clean and grease the silicone insulating part of the voltage transformer as described in section 2.1.3.

- Remove the dust protection caps or blanking plugs from the voltage transformer sockets and store the components for further use.



Clean the voltage transformer socket as described in section 2.1.3.

¹⁾ mcb: miniature circuit breaker

Voltage transformers for operating voltages > 24 kV



Earth the threaded bores in the voltage transformer sockets by fitting them with countersunk screws, DIN 7991, M 8 x 30 (unless already fitted). (Figure 2.3.7.2.1).

- In the case of systems with an operating voltage > 24 kV, hexagonal pins are used to fasten the voltage transformers. Screw the hexagonal pins to the studbolts on the enclosure (tightening torque 12.5 Nm) as shown in figure 2.3.7.5.1.

- Slowly and carefully insert the transformer into the socket. The plug-in connection must slide easily into the corresponding socket. Check the position of the silicone parts in relation to the socket continuously and correct if necessary. A counter-pressure will become noticeable approx. 20 mm before the limit position is reached.

- Initially, only fasten the voltage transformer with screws at the points marked in figure 2.3.7.5.2. Install the further voltage transformers in the same way.

Fig. 2.3.7.5.1: Hexagonal pins for fastening of the voltage transformer

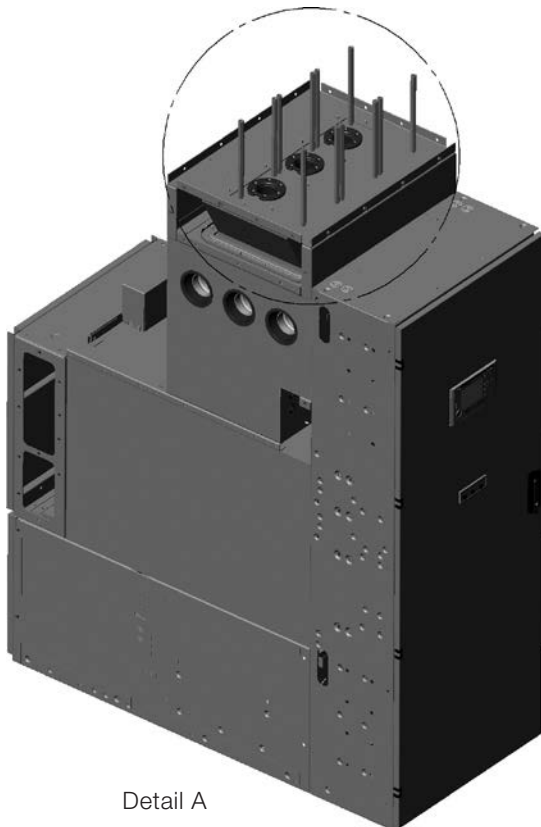

Detail A

Hexagonal pin

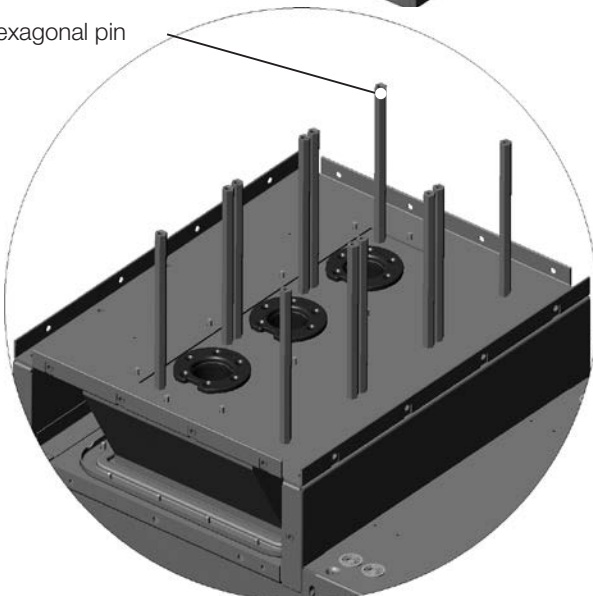
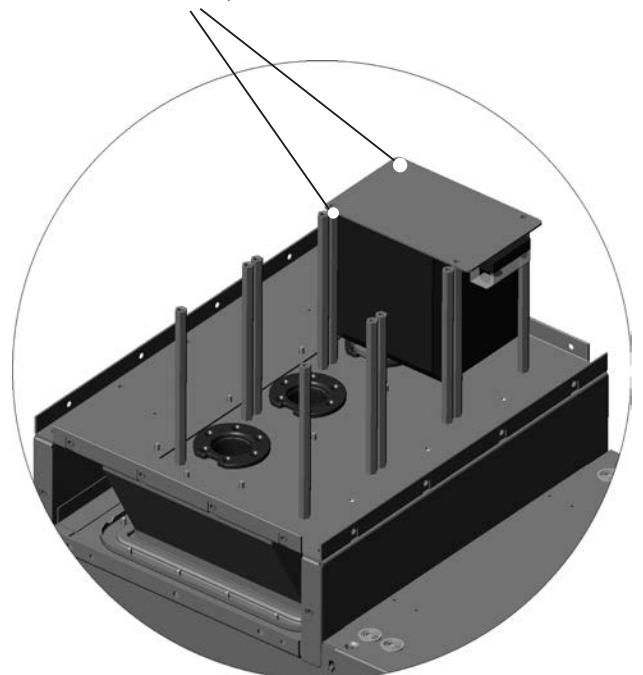

Fig. 2.3.7.5.2: Fastening of the voltage transformer, version for operating voltage > 24 kV

2 x cheese head screw, M 10 x 25 DIN 912
2 x dished washer, 10 DIN 6796



Voltage transformers for operating voltages up to 24 kV

- Remove the three earthing screws (figure 2.3.7.2.1) on the flange of the voltage transformer socket, if fitted.
- Slowly and carefully insert the transformer into the socket. The plug-in connection must slide easily into the corresponding socket. Check the position of the silicone parts in relation to the socket continuously and correct if necessary. A counter-pressure will become noticeable approx. 20 mm before the limit position is reached.
- Screw the flange of the voltage transformer to the voltage transformer socket (see figure 2.3.7.5.3) in the panel, tightening the screws across the diagonal.

The further installation procedure is identical for both types of voltage transformer.

- Wipe any surplus grease off from the area of the voltage transformer flange above the voltage transformer's plug-in connection as far as possible.
- Screw the fastening bracket to the roof plate of the pressure relief duct as shown in figure 2.3.7.5.4.

Fig. 2.3.7.5.3: Fastening of the voltage transformer, version for operating voltage up to 24 kV

3 x cheese head screw M 8 x 40 DIN 912
3 x washer 8,4 DIN 433
3 x spring washer A8 DIN 127

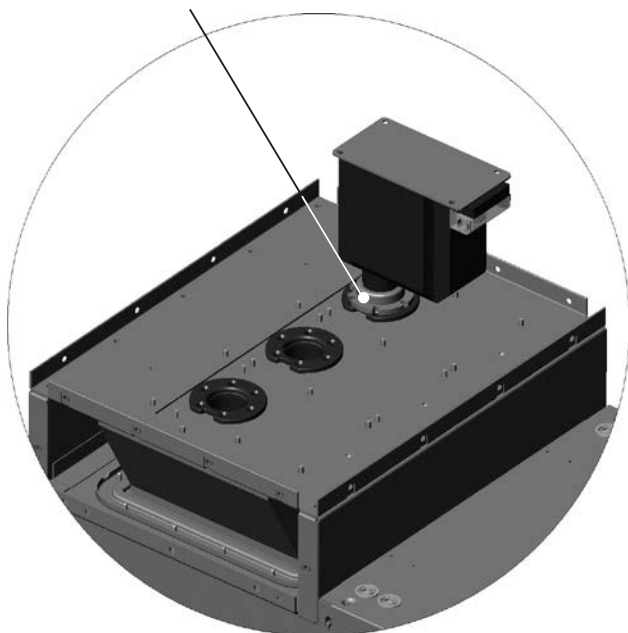
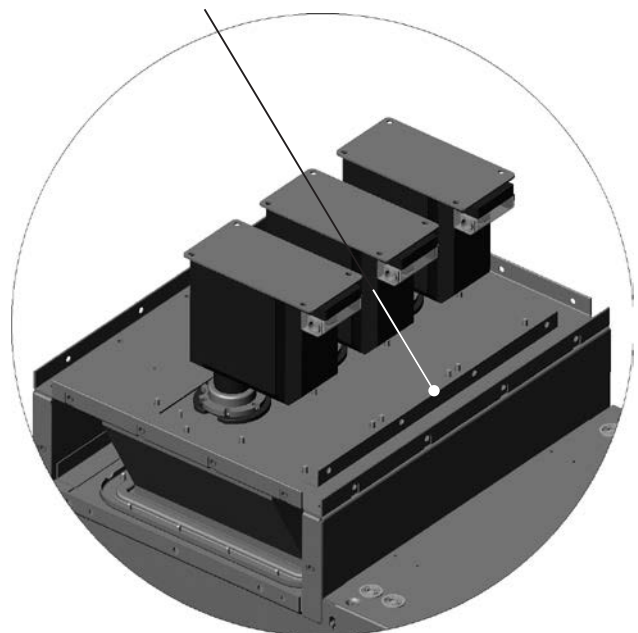

Fig. 2.3.7.5.4: Fitting the fastening bracket

Fastening bracket
3 x cheese head screw M 8 x 20 DIN 912
3 x dished washer 8 DIN 6796



- Fasten the transformer cover to the previously fitted fastening bracket and to the top plates of the voltage transformers (figure 2.3.7.5.5).
- Lead the transformer wiring through the gland in the transformer cover.
- Wire the transformers as set out in section 2.3.7.8.
- Install the damping resistor if necessary (figure 2.3.7.5.7).
- Lead the wiring for the damping resistor through the gland in the transformer cover.
- Connect the damping resistor in accordance with the wiring diagram.
- Fit the cover plate (figure 2.3.7.5.6).

Fig. 2.3.7.5.5: Assembly of the transformer cover

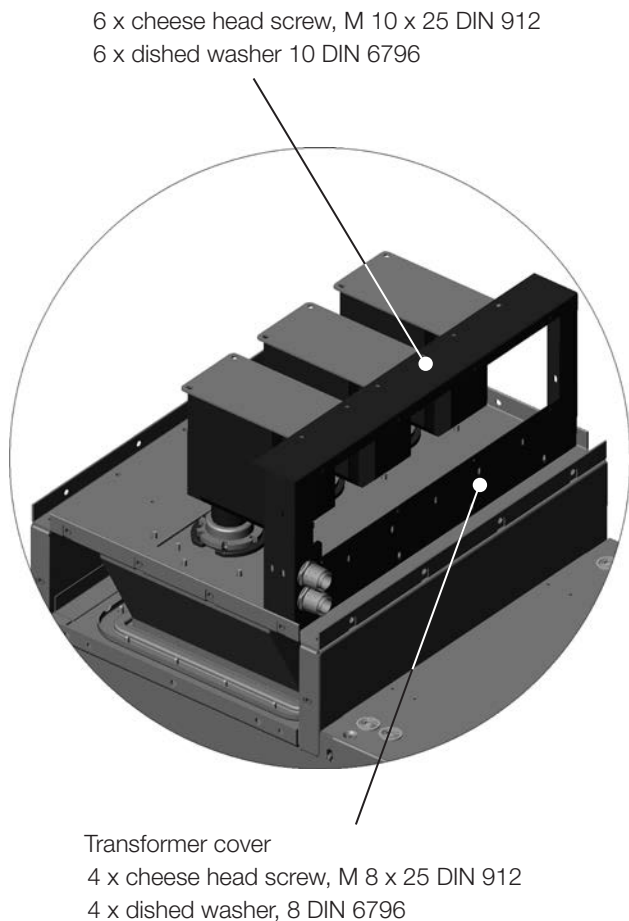
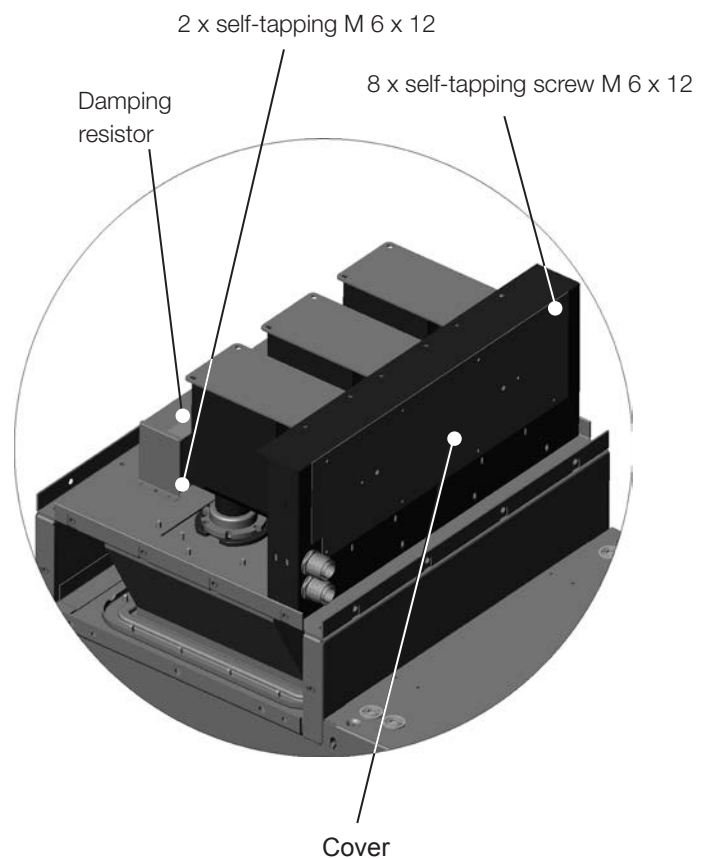

Fig. 2.3.7.5.6: Fitting the damping resistor and the cover plate



Installation of the casing (fig. 2.3.7.5.7)

- First fit the C section above the transformer cover. Use the available transformer fastening screws.
- Screw the two side plates to the inside of the transformer cover.
- Screw the rear cover to the side covers.
- Finally fasten the top plate to the plates previously fitted.

Fig. 2.3.7.5.7: Installation of the casing

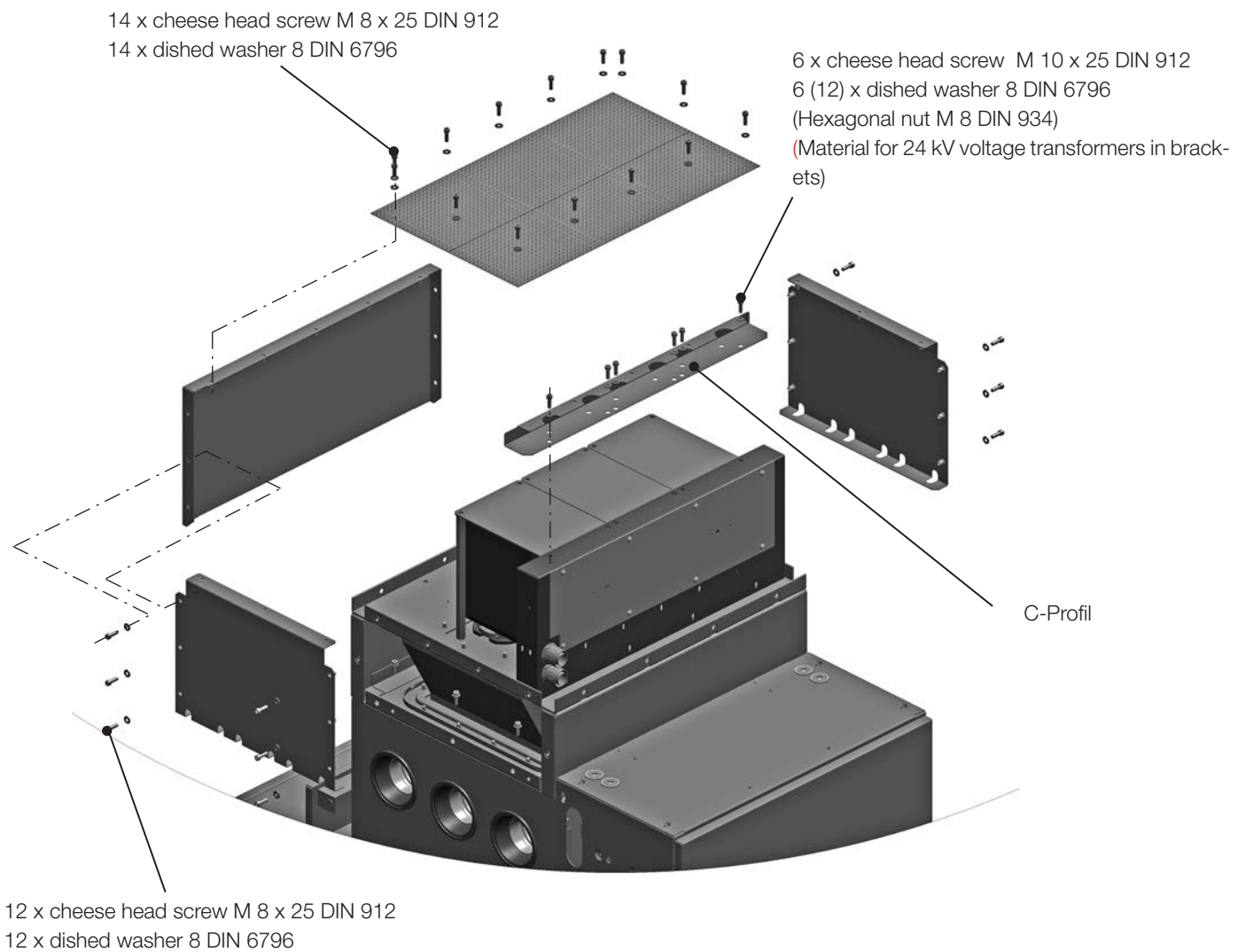

2.3.7.6 Dismantling of voltage transformers (metering 3)



If the switchgear is in operation:

- Isolate the relevant switchgear section before dismantling the voltage transformers.
- Comply with the safety regulations of EN 50110.
- Test the switchgear section for the off-circuit condition in accordance with section 5.1.
- Earth switchgear section and secure the working area in accordance with section 4 and EN 50110 standard.
- Switch the mcbs ¹⁾ for the relevant operating mechanisms off so that the switchgear section cannot be switched on by remote control.

- Dismantle the cover plate (figure 2.3.7.5.7).
- Dismantle the wiring for the voltage transformers and the damping resistor as far as necessary.
- Dismantle the transformer cover (figure 2.3.7.5.5).
- Start the dismantling procedure with one of the outer voltage transformers.

Voltage transformers for operating voltages > 24 kV

- Remove the two screws on the hexagonal pins as shown in figure 2.3.7.5.2.

Voltage transformers for operating voltages up to 24 kV

- Remove the screws in the flange of the voltage transformer.

The further dismantling procedure is identical for both types of voltage transformers.

- Draw the voltage transformers vertically out of the sockets.
- Cover the silicone insulating parts of the voltage transformers with the protective caps supplied to protect them from soiling and damage.
- Remove the three earthing screws (figure 2.3.7.2.1) on the flange of the voltage transformer socket, if fitted.
- Close off the open voltage transformer sockets with insulating blanking plugs prior to bringing the panel on line or performing high voltage testing.

¹⁾ mcb: miniature circuit breaker

2.3.7.7 Installation of voltage transformers (metering 4)



If the switchgear is in operation:

- Isolate the relevant switchgear section before dismantling the voltage transformers.
- Comply with the safety regulations of EN 50110.
- Test the switchgear section for the off-circuit condition in accordance with section 5.1.
- Earth switchgear section and secure the working area in accordance with section 4 and EN 50110 standard.
- Switch the mcbs ¹⁾ for the relevant operating mechanisms off so that the switchgear section cannot be switched on by remote control.

- Remove the protective caps from the silicone parts of the voltage transformers and store them for further use.



Check the silicone part of the voltage transformer for damage. Observe the notes in section 2.1.3.



Clean and grease the silicone insulating part of the voltage transformer as described in section 2.1.3.

- Remove the protective caps from the silicone parts of the voltage transformers and store them for further use.



Clean the voltage transformer socket as described in section 2.1.3.



Earth the threaded bores in the voltage transformer sockets by fitting them with countersunk screws, DIN 7991, M 8 x 30 (unless already fitted). (Figure 2.3.7.2.1).

Fig. 2.3.7.7.1: Hexagonal pins for fastening of the voltage transformer

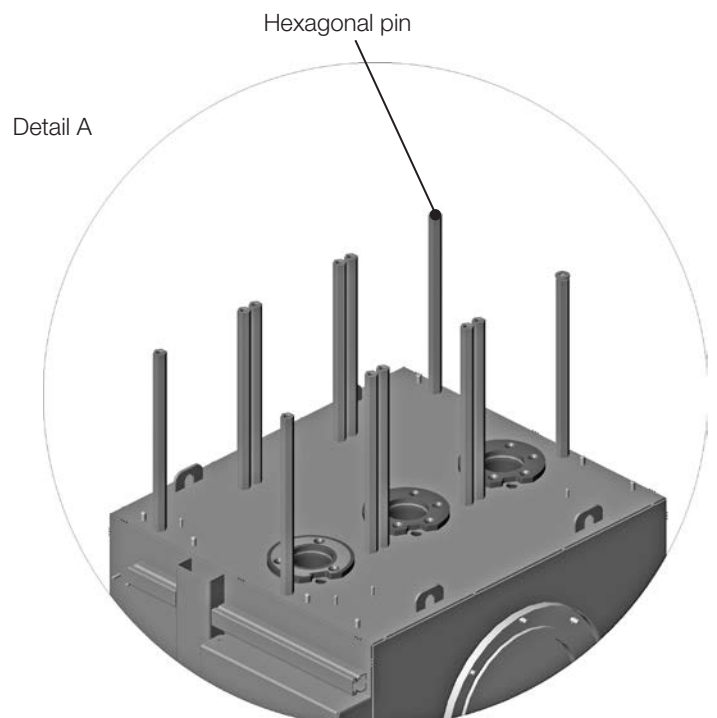
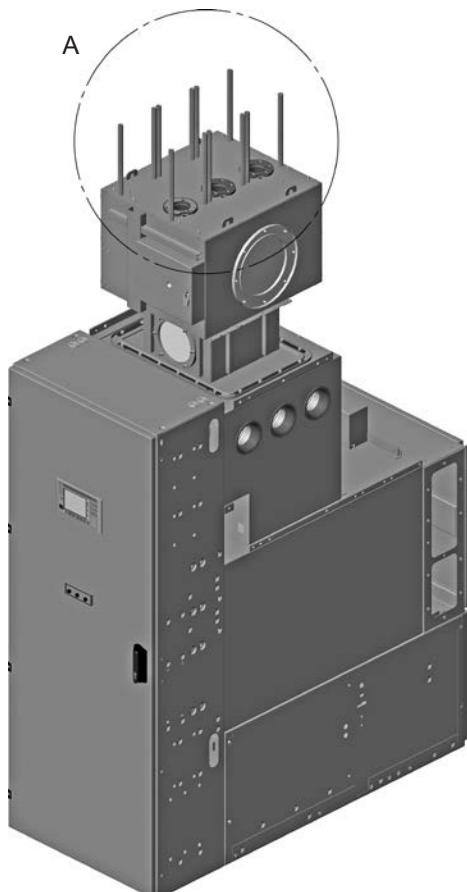

- Screw the hexagonal pins to the studbolts on the enclosure (tightening torque 12.5 Nm) as shown in figure 2.3.7.7.1
- Slowly and carefully insert the transformer into the socket. The plug-in connection must slide easily into the corresponding socket. Check the position of the silicone parts in relation to the socket continuously and correct if necessary. A counter-pressure will become noticeable approx. 20 mm before the limit position is reached. (Fig. 2.3.7.7.2).
- Install the further voltage transformers in the same way.
- Install the damping resistor if necessary (Fig. 2.3.7.7.3).

Fig. 2.3.7.7.2: Fastening of the voltage transformer

- 4 x cheese head screw M 10 x 25 DIN 912
- 4 x dished washer 10 DIN 6796

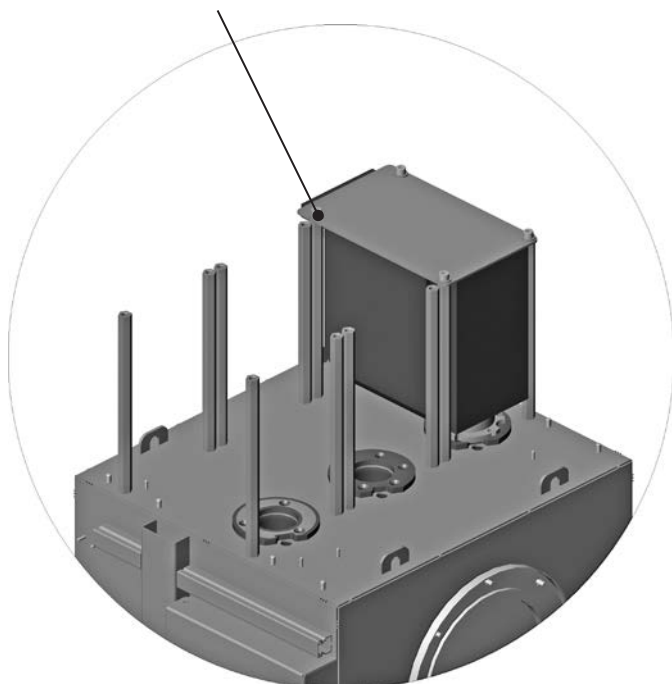
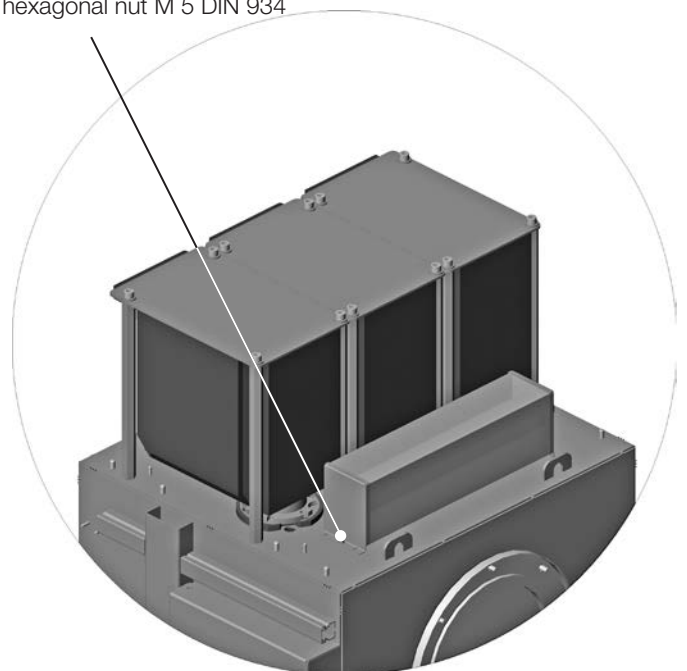

Fig. 2.3.7.7.3: Fastening of the damping resistor

- 2 x washer A 5,3 DIN 433
- 2 x spring washer A 5 DIN 127
- 2 x hexagonal nut M 5 DIN 934



Installation of the optional casing (fig. 2.3.7.7.4)

- Screw the cover plate (1) to the top-mounted box (fig. 2.3.7.7.4).
- Slide the hose glands over the cable harnesses prepared at the works which are provided for the transformer wiring and a damping resistor if fitted. Guide the cable harnesses through the relevant opening in the cover plate. Slide the nuts for the hose glands over the relevant cable harnesses. Install the hose glands.
- Wire the transformers as stated in section 2.3.7.8, and any damping resistor as shown on the wiring diagram. For wiring, use cable ties screwed to the M5 studbolts and twist lock fasteners as holding points for cable ties.
- Close the openings in the cover plate (2) with PVC reducer rings. Fit the cover plate (2), the side plates and the top plate with the fastening materials listed in fig. 2.3.7.7.4.

Fig. 2.3.7.7.4: Installation of the optional casing

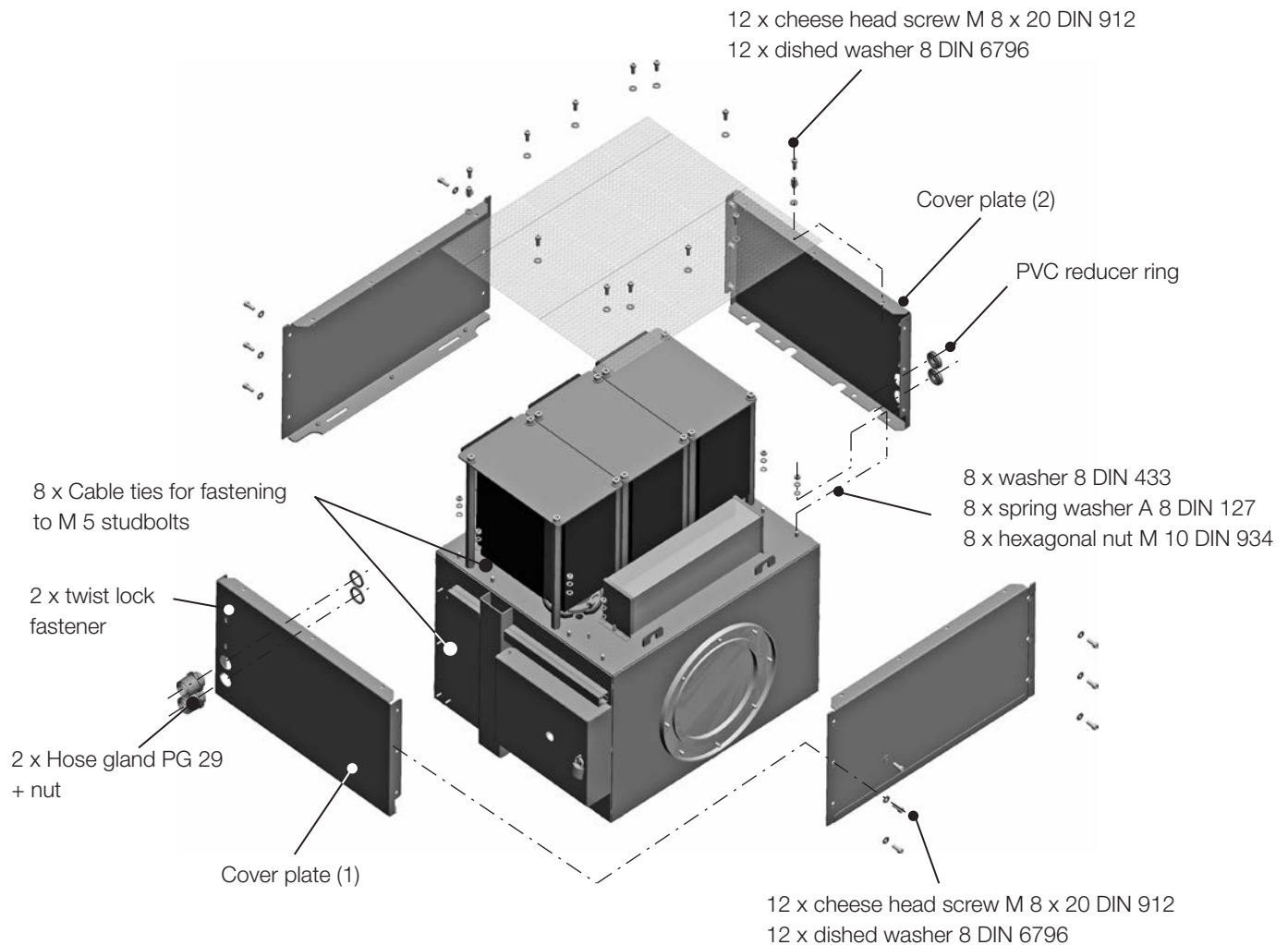

2.3.7.8 Wiring of the voltage transformers

The voltage transformers are fitted with terminal boards. The possible configurations of terminal boards can be found in figure 2.3.7.8.1 and table 2.3.7.8.1.

Fig. 2.3.7.8.1: Possible terminal board configurations

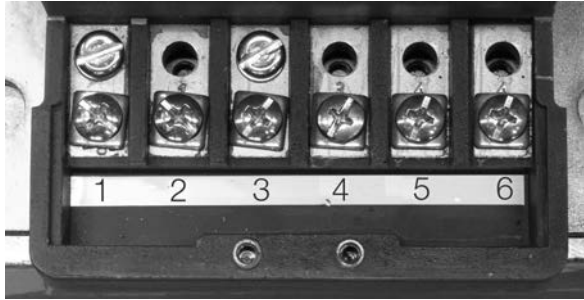

Table 2.3.7.8.1: Possible terminal board configurations

Windings			Terminal					
Number	Tap	e-n winding	1	2	3	4	5	6
1			N	a	n			
1		•	N	a	n	da	dn	
1	•		N	a1	a2	n		
1	•	•	N	a1	a2	n	da	dn
2			N	1a	1n	2a	2n	
2		•	1a	1n	2a	2n	da	dn
2	•		1a1	1a2	1n	2a1	2a2	2n

In a voltage transformer version with 2 windings plus tap or 2 windings plus e-n winding, "N" is implemented at the base plate of the voltage transformer.

Earthing of terminals on the voltage transformer terminal board using earthing screws

Connections to earth potential can be established by means of earthing screws on the terminals of the terminal board. Figure 2.3.7.8.2 illustrates this using the example of a voltage transformer with one secondary winding.

Fig. 2.3.7.8.2: Earthing of terminals using earthing screws

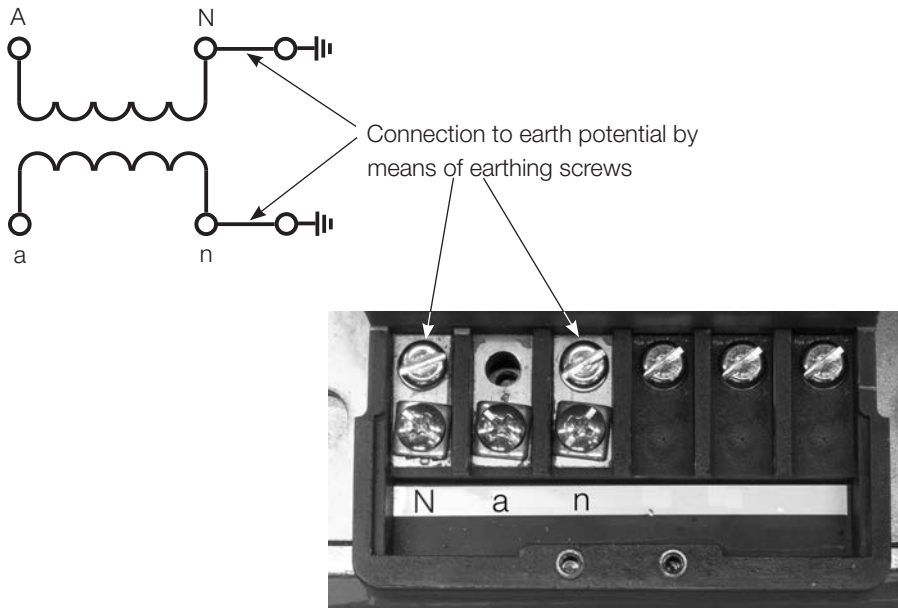

Wiring the voltage transformers

The cable harnesses for wiring of the transformers are prepared at the works and wired to the low voltage compartment. Wire the transformers as follows.



Wire the secondary terminals and the earthing of the voltage transformers in accordance with the circuit diagrams.

Check that all terminal screws including the earthing screws are tightly fastened.

Releasing the earthing screw on the 'N' terminal leads to potentially lethal high voltage at the terminal when the voltage transformer is in operation!

Releasing the earthing screw on the 'N' terminal is only permissible for test purposes on voltage transformers with de-energized primary!

Always use the original earthing screws!

Earthing of e-n windings

If the e-n windings of the voltage transformers are damped with a resistor, the windings connected in an open delta are to be earthed **at one point**. The circuit can be earthed

- in the low voltage compartment (figure 2.3.7.8.3) or
- on the terminal block of a voltage transformer (figure 2.3.7.8.4).

Perform measurements to ascertain which earthing method applies to your system.

Fig. 2.3.7.8.3: Earthing of the circuit in the low voltage compartment

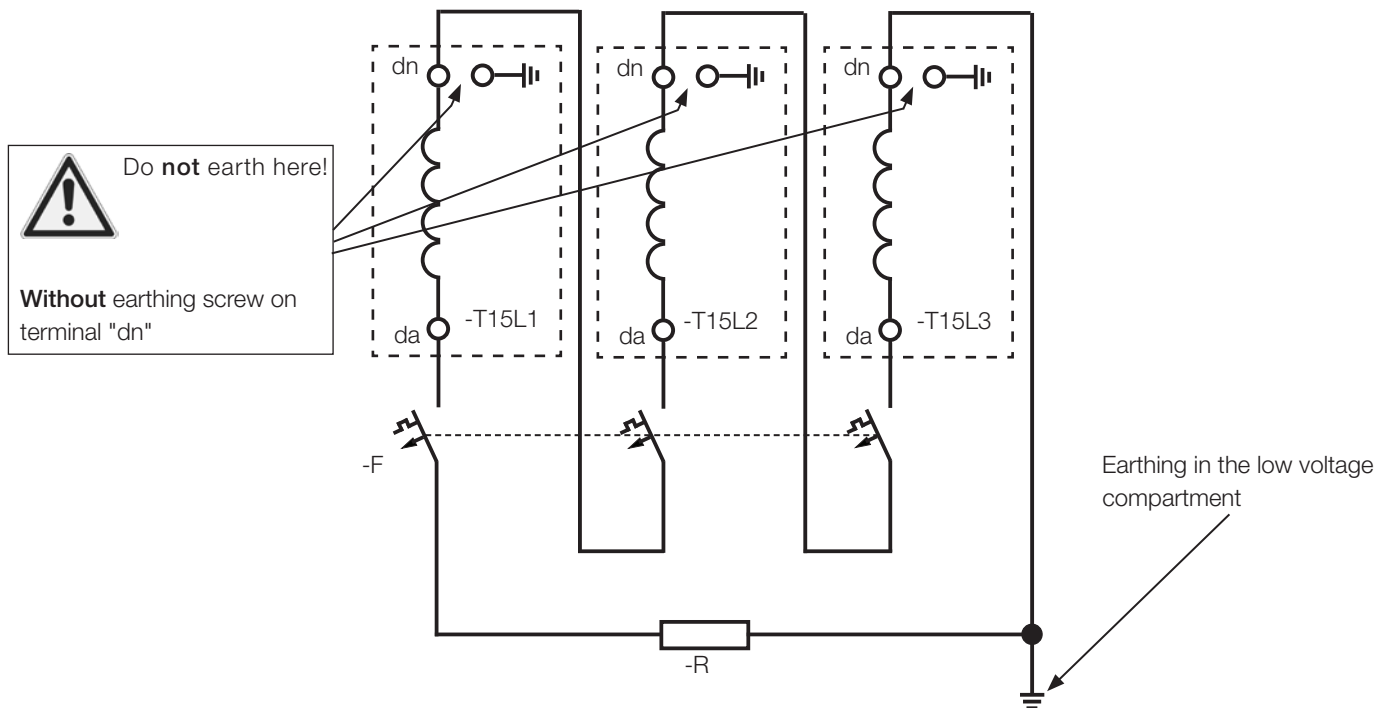
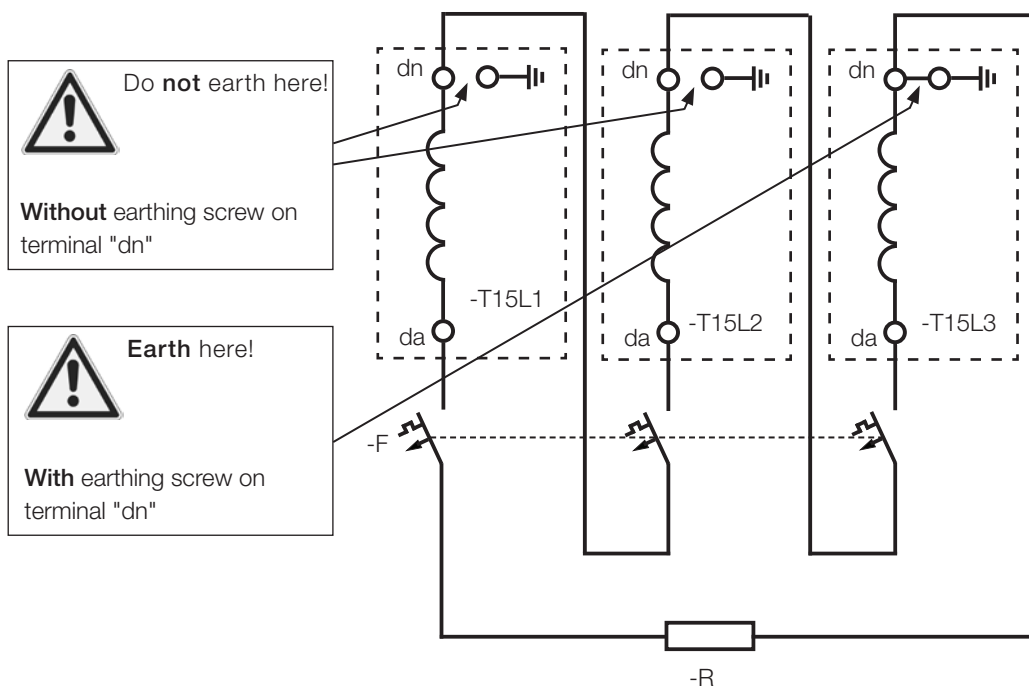

Fig. 2.3.7.8.4: Earthing the circuit on the terminal board of a transformer





Remove the earthing screws of the e-n windings from the terminal boards of the voltage transformers in accordance with the circuit diagrams (figure 2.3.7.8.5) or earth the e-n windings using the earthing screw (figure 2.3.7.8.6).

Earth the circuit at one point only.

Fig. 2.3.7.8.5: View of the terminal board of a voltage transformer with e-n winding: Earthing screw (arrow) in isolated position (no earthing)

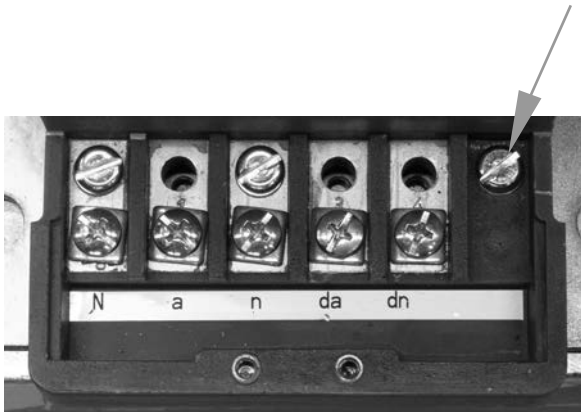
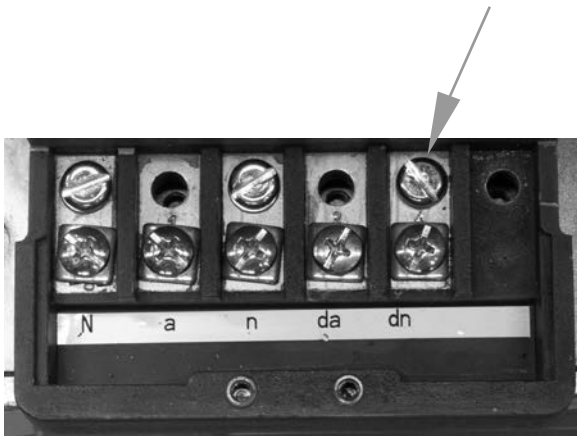

Fig. 2.3.7.8.6: View of the terminal board of a voltage transformer with e-n winding: Earthing screw (arrow) in earthing position (dn terminal earthed)



Checking the wiring



Finally, check the earthing system of the voltage transformer wiring in accordance with table 2.3.7.8.2.

Table 2.3.7.8.2: Earthing of terminals on the voltage transformer terminal board

Windings			Terminals					
Number	Tap	e-n winding						
1			N	a	n			
1		•	N	a	n	da	dn	
1	•		N	a1	a2	n		
1	•	•	N	a1	a2	n	da	dn
2			N	1a	1n	2a	2n	
2		•	1a	1n	2a	2n	da	dn
2	•		1a1	1a2	1n	2a1	2a2	2n

N

The terminal must be earthed via the earthing screw!

n

Earthing of the terminal in accordance with the circuit diagram!

dn

Earthing screw fitted in accordance with the circuit diagram and figure 2.3.7.8.3 or 2.3.6.4.4!

When 2 windings plus a tap or 2 windings plus e-n winding, are used, "N" is implemented by the works at the base plate of the voltage transformer.

2.4 Connection of cables and wiring

2.4.1 Control cables and wiring

- Establish the panel to panel connections of the control wiring. The panel to panel connections are of the plug-in type.
- The secondary cable entry for external control cables and wiring is located in the floor plate of the low voltage compartment. Lead external control cables and wiring through the floor plate using reducer rings, and connect these in accordance with the wiring diagram.

Earth the cable screen for the external control cables in accordance with the accepted EMC (electromagnetic compatibility) rules.

 External control cables should be screened.

 The lengths of the external control cables should not exceed 200 m. With greater lengths, use for example interposing relays or optical fibre cables.

2.4.2 High voltage cables

The high voltage cables are to be installed after high voltage testing.

- Dismantle the floor plates of the cable termination compartments. Remove the cable bushings from the floor plates.
- Lay the high voltage cables to the panels in accordance with the project planning.

 Ensure that the phase positions of the cables are correct!

- Slide the cable bushings over the cables.
- Connect the cable connectors to the cables in accordance with the manufacturer's instructions.



Checking the cable sockets and/or the outer cones

 Check the cable sockets and/or the outer cones for damage. If there is damage to the outer cones, please contact our service department.

Cleaning the cable sockets and/or the outer cones

Remove any surplus or dirty grease or soiling from the cable sockets and/or the outer cones with a soft, clean, non-fraying cloth. Use intensive cleaner M.X.T. 60 forte for cleaning if necessary.

Fitting the cable connectors

- Connect the cable connectors to the relevant cable sockets or outer cones in accordance with the manufacturer's instructions.
 - Connect the earthing conductors of the cable screens to the earthing bar in the panel.
 - If window-type current transformers are used, route the earthing conductors of the cable screen back through the current transformers and connect the earthing conductor to the earthing bar in the panel.
-  The earthing conductors of the cable screens should always be routed to the earthing bar in the shortest possible distance.
-  Observe the tightening torques for screw connections given in the cable connector manufacturer's instructions.
- Press the cable bushings into the openings provided in the floor plates.
 - Refit the floor plates and covers on the panels.

2.5 Fitting surge arresters



If the switchgear is in operation:

- Isolate the relevant feeder panel before installing the surge arresters.
- Comply with the safety regulations of EN 50110.
- Test the feeder panel for the off-circuit condition in accordance with section 5.1.
- Earth the feeder panel and secure the working area in accordance with section 4 and EN 50110 standard.
- Switch the mcbs ¹⁾ for the relevant operating mechanisms off so that the feeder panel cannot be switched on by remote control.

- Remove the cover of the cable termination compartment.
- Remove the dust protection caps or blanking plugs from the test sockets and store the components for further use.



Prepare the surge arresters in accordance with the manufacturer's instructions.



Install the surge arresters in accordance with the manufacturer's instructions.

- Connect the earthing terminal of the surge arrester to the main earthing bar of the panel using the wires provided (cross section 16 mm² with cable lugs), as shown in figure 2.5.1. Configure the connection of the earthing leads to the surge arrester in accordance with the manufacturer's instructions.
- Fit and screw in the cover of the cable termination compartment.

Fig. 2.5.1: Earthing of surge arresters

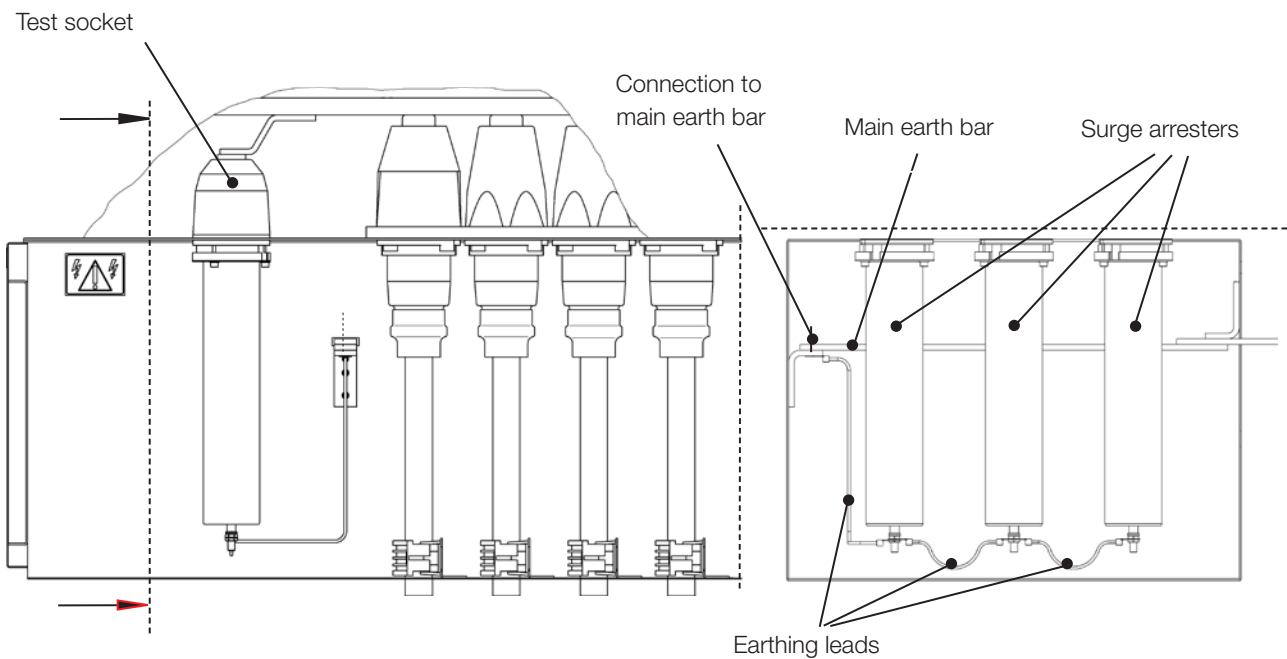

¹⁾ mcb: miniature circuit breaker

2.6 Fitting blanking plugs



Close off unused cable sockets and voltage transformer sockets with blanking plugs as follows:



Treat the silicone insulating parts of the blanking plugs and the sockets for the voltage transformers as described in section 2.1.3.



Remove the three earthing screws (figure 2.3.6.2.1) on the flange of the voltage transformer socket, if fitted.

- Insert the blanking plugs into the sockets and, without tilting them, fasten them in place by tightening the screws across the diagonal to the specified tightening torque (section 2.1.2).

2.7 Fitting insulating covers for unused outer cones in double panels



Close off all unused outer cones with insulating covers in accordance with the manufacturer's instructions.

2.8 Connecting the main earthing bar

- Connect the main earthing bar to the station earth.



Details of the cross section and the number of connections can be found in the earthing diagram (not included in ABB's scope of supply).

- Establish the earthing connections in accordance with IEC 61936 and IEC 62271-1 from the points of view of shock-proof capability, short-circuit capability and electromagnetic compatibility (EMC).

2.9 Concluding installation work

- Remove all tools and other foreign bodies from the switchgear.
- Refit any cladding, covers, cable ducts, etc. removed during the installation work.



Use only chlorine-free cleansers for cleaning of the switchgear.

- Clean the external surfaces of the enclosure and low voltage compartments where necessary.
- Touch up any damage to paintwork with a suitable paint.
- Check that the switchgear room is in proper condition for operation and establish that condition if necessary.

3 Commissioning

3.1 Conditions for commissioning of the switchgear

The conditions for commissioning of the switchgear are as follows:

- Supply voltage is available.
 - There are no active SF₆ gas pressure alarms.
 - Visual examination and sample checks on installation in accordance with this document have been performed.
 - External control cables and wiring have been installed.
 - Testing of the specified protection data of the secondary equipment has been successfully performed.
 - Protection testing has been passed.
 - Testing of all mechanical and electrical functions of the switching devices and corresponding operating mechanisms has been successfully performed.
 - Testing of the panel and switchgear interlocks has been successfully performed.
 - Several trial switching operations (without service voltage) on all switching devices have been successfully performed.
 - Switch positions are correctly displayed on the panels and – if necessary – in the control room.
 - If remote control systems are fitted, these have been successfully tested.
 - Unused cable sockets, voltage transformer sockets and extendable busbar sockets have been closed off with insulating blanking plugs.
 - Unused outer cones have been closed off and insulated.
 - High voltage testing at 80 % of rated short-duration power-frequency withstand voltage U_d to IEC 62271-200 has been passed.
 - High voltage cables have been installed (after performance of high voltage testing).
 - All cladding and covers have been fitted.
- The following accessories have been handed over to the operators:
- This manual
 - The corresponding documents and order documents
 - Double bit key or barrel lock key for opening and closing of the low voltage compartment doors
 - Levers and cranks for operation of the operating mechanisms (see list of accessories)
 - Earthing set (optional)
 - Plug-in indicator unit for capacitive indication – if necessary (see section 5.1)
 - Phase comparator in the case of more than one incoming feeder (optional)
 - Crank for voltage transformer truck.
 - A work instruction for handling of SF₆ (an example can be found in instruction manual HB 605/E) is displayed in the switchgear room.
 - The operators have been instructed in the theory and practice of operation of the switchgear and are familiar with all details of operation.

3.2 Energizing the system

Switchgear with single busbar

- Please consult section 4 for procedures for operating the devices. Also observe section 3.1.
- Close all low voltage compartment doors.
- Switch all circuit-breakers off.
- Switch all three position disconnectors off.

Connecting the incoming feeder panels

- Switch the three position disconnector in the incoming feeder panel to the “Disconnecter ON” position.
- Switch the circuit-breaker in the incoming feeder panel “ON”.
- The busbar is then at operating voltage.



Before connecting further incoming feeder panels, ensure that the phase angle of the panels is identical (section 5.2).

Connecting the outgoing feeder panels

- Switch the three position disconnector in the outgoing feeder panel to be connected to the “Disconnecter ON” position.
- Switch the circuit-breaker in the outgoing feeder panel “ON”.
- The load is then switched on.

Switch the further loads on as described.

The switchgear is in operation.

Switchgear with double busbar

- Please consult section 4 for procedures for operating the devices. Also observe section 3.1.
- Close all low voltage compartment doors.
- Switch all circuit-breakers off.
- Switch all three position disconnectors and disconnectos off.

Connecting the incoming feeder panels

- Switch the three position disconnector or the disconnector in the incoming feeder panel to the “Disconnecter ON” position.
- Switch the circuit-breaker in the incoming feeder panel “ON”.
- The busbar is then at operating voltage.



Before connecting further incoming feeder panels, ensure that the phase angle of the panels is identical (section 5.2).

Connecting the outgoing feeder panels

- Switch the three position disconnector or the disconnector (whichever conducts busbar voltage) in the outgoing feeder panel to be connected to the “Disconnecter ON” position.
- Switch the circuit-breaker in the outgoing feeder panel “ON”.
- The load is then switched on.

Switch the further loads on as described.

The switchgear is in operation.

4 Operation

- All activities in connection with operation of the switchgear require compliance with EN 50110 standard or relevant national regulations regarding the operation of electrical installations (see also page 6).
- Always make sure that switching operations have been completed before performing the next switching operation.

4.1 General notes

The three switching positions of the three position disconnecter, "connecting", "disconnecting" and "preparing for earthing" are clearly defined by the mechanical structure of the switch. Connecting and disconnecting the operating current and earthing are performed exclusively by the circuit-breaker. (Figures 4.1.1 to 4.1.4). Figures 4.1.5 to 4.1.9 show the operating sequence for earthing of a busbar by means of the bus tie, on the basis of an example switchgear system.

In order to avoid maloperation, the operating mechanisms of any panel are electrically, and as an option mechanically interlocked.

- The three position disconnecter (disconnecter and earthing switch function) can only be operated when the circuit-

breaker is open. The earthing switch can only be operated when the disconnecter is open. The disconnecter can only be operated when the earthing switch is open.



Please consult the order documents for the conditions of further internal electrical interlocks in the panels (e.g. disconnecter – disconnecter interlocks in double busbar systems) and panel to panel electrical interlocks.

4.2 Notes on earthing of a feeder panel or system section



When the feeder panel or section of the system has been earthed by operating the earthing switch and circuit-breaker (figures 4.1.1, 4.1.3 and 4.1.5 to 4.1.9), secure it to prevent cancellation of earthing as follows:

Switch the mcbs for the circuit-breaker release circuit and for the motor-operated mechanism of the three position switch in the relevant panel off.

Lock the low voltage compartment door or where appropriate the mechanical OFF button for the circuit-breaker.

Affix a sign to the panel to indicate that earthing has been performed

Fig. 4.1.1: Earthing a feeder and cancelling the earthing, single busbar

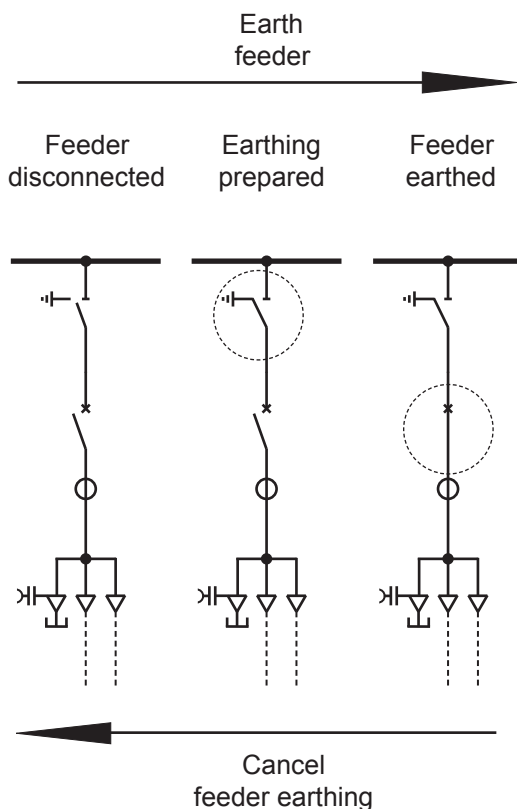
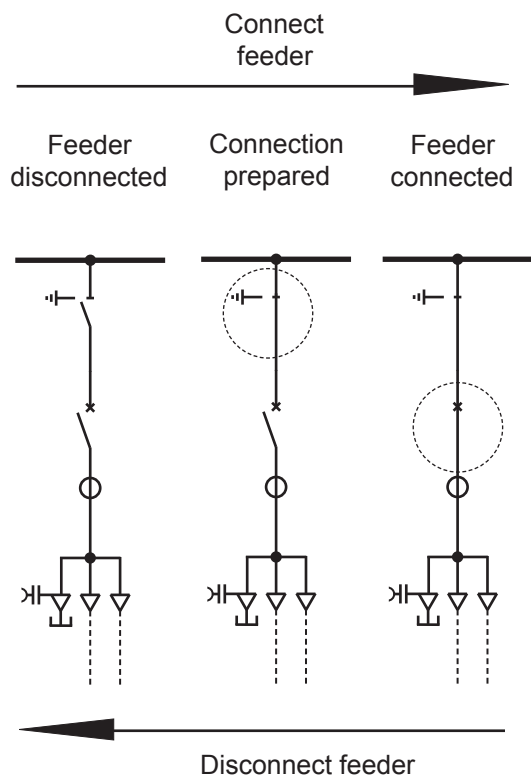

Fig. 4.1.2: Connecting and disconnecting a feeder panel, single busbar



¹⁾ mcb: miniature circuit breaker

Fig. 4.1.3: Earthing a feeder and cancelling the earthing, double busbar

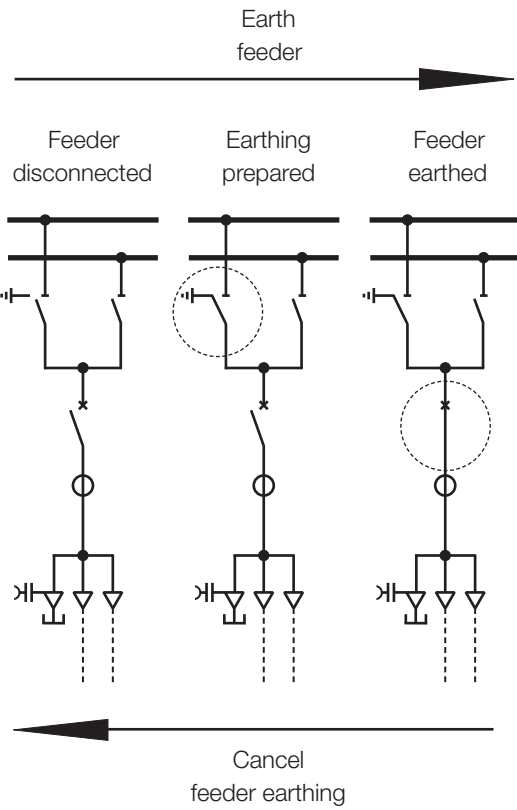
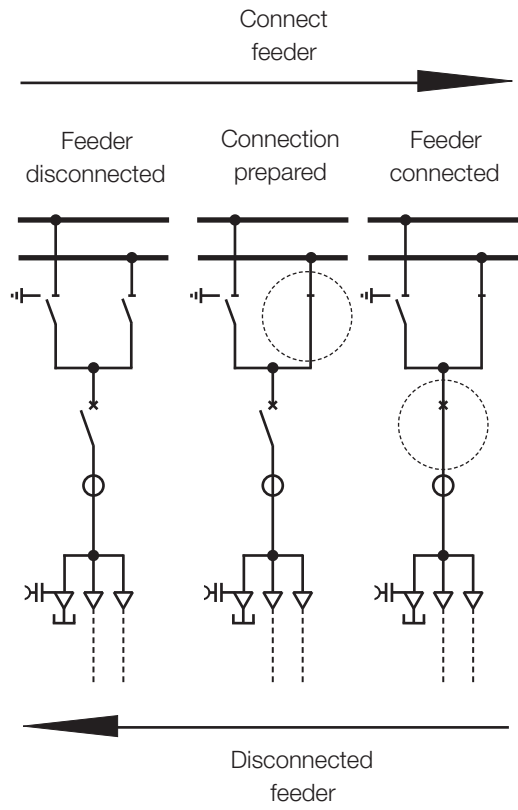

Fig. 4.1.4: Connecting and disconnecting a feeder panel, double busbar



Figures 4.1.5 to 4.1.8 show the operating sequence for earthing of busbar 2 (SS2) in an example switchgear system.

Fig. 4.1.5: Example switchgear system, double busbar with bus tie, system in operation via busbar 2 (SS2)

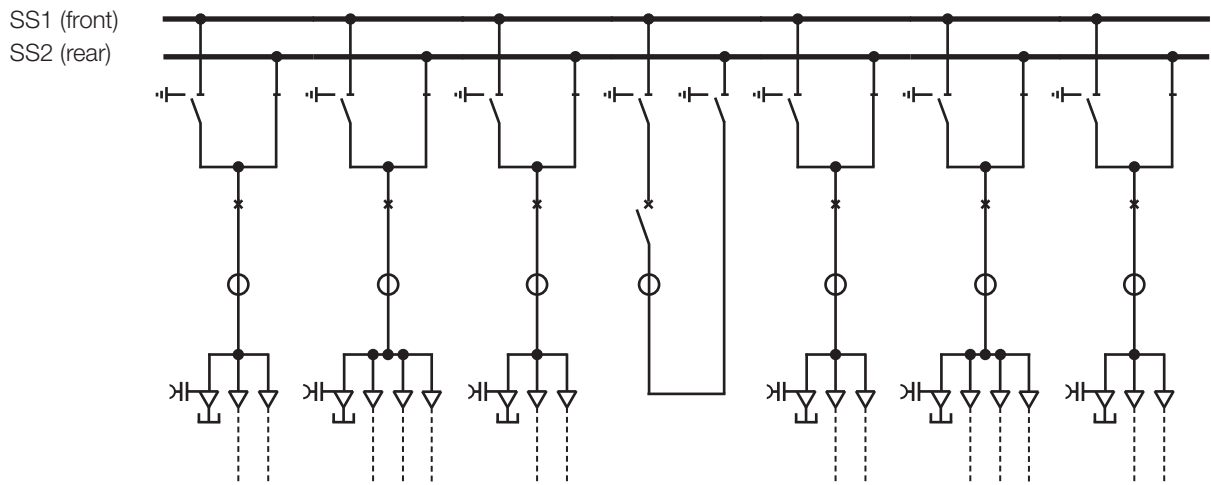

Fig. 4.1.6: Closing the disconnecter (busbar 1) in the bus tie

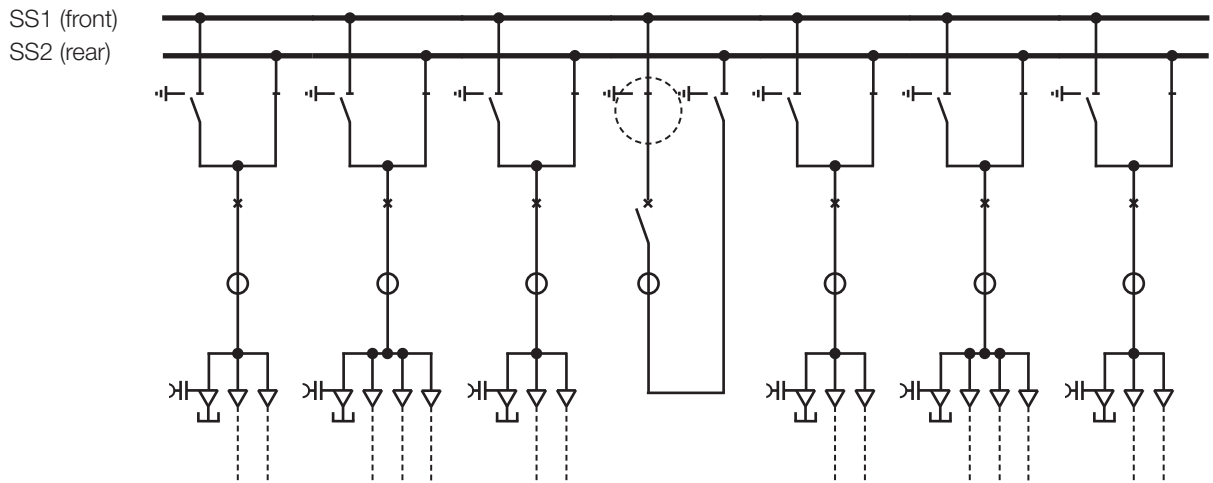

Fig. 4.1.7: Closing the earthing switch (busbar 2) in the bus tie

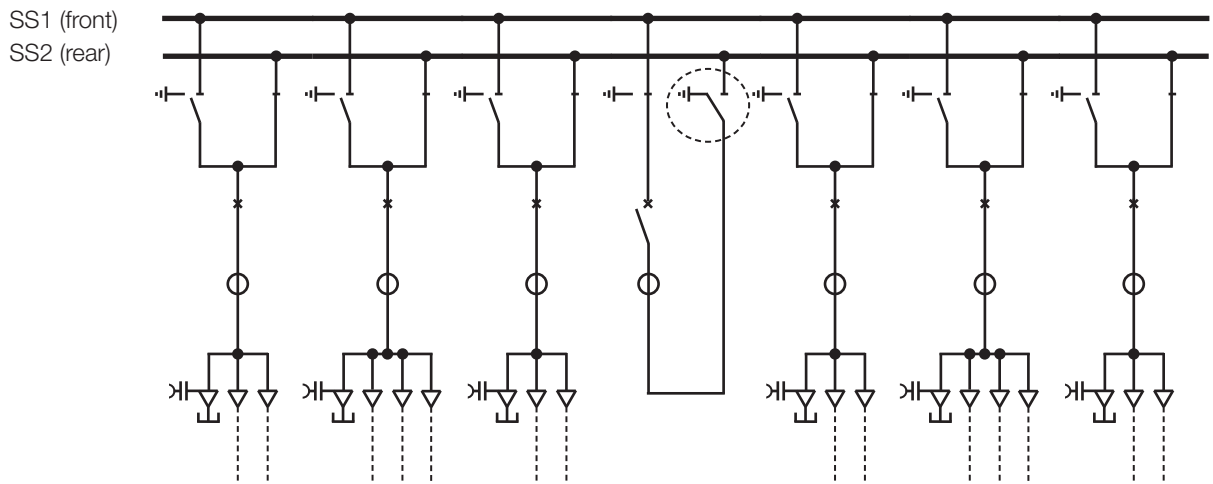
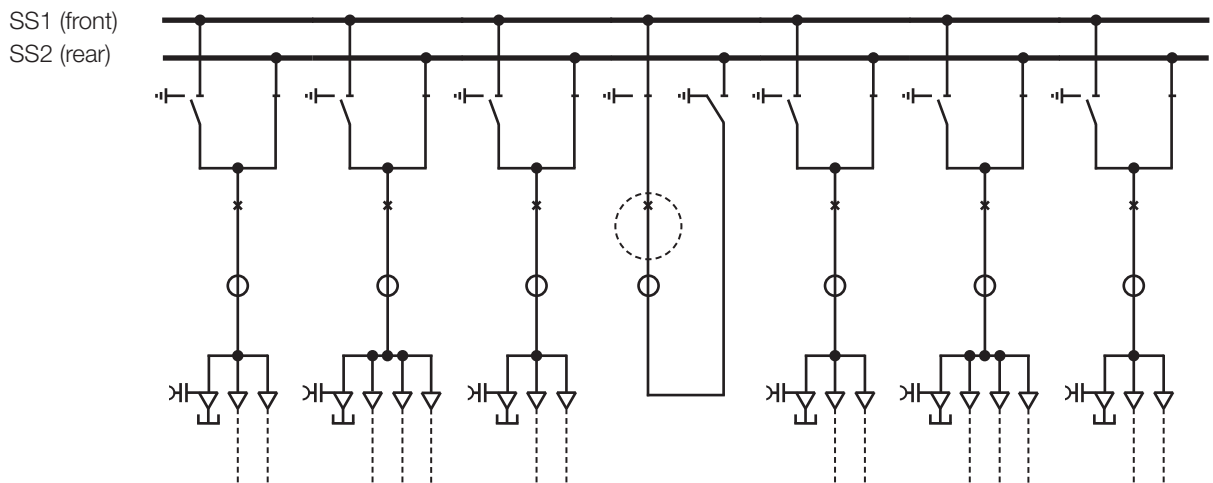

Fig. 4.1.8: Closing the circuit-breaker in the bus tie: Busbar 1 earthed



4.3 Electrical operation

In normal cases, all switches are operated electrically by means of

- a combined protection and control unit, or
- classically by conventional ON and OFF buttons

in general with the low voltage compartment door closed.



Opening the low voltage compartment door permits intervention in the interlock system.

Use of the protection and control unit



Information on operation of the protection and control unit can be found in the separate instruction manual.

Conventional solution (figure 4.3.1)

Closing and opening of the circuit-breakers, three position disconnectors and disconnectors are effected by ON and OFF buttons. The positions of the switching devices are displayed by LEDs or optionally with the aid of electro-mechanical bar indicators.

Fig. 4.3.1: Standard solution for conventional control and display at the panel

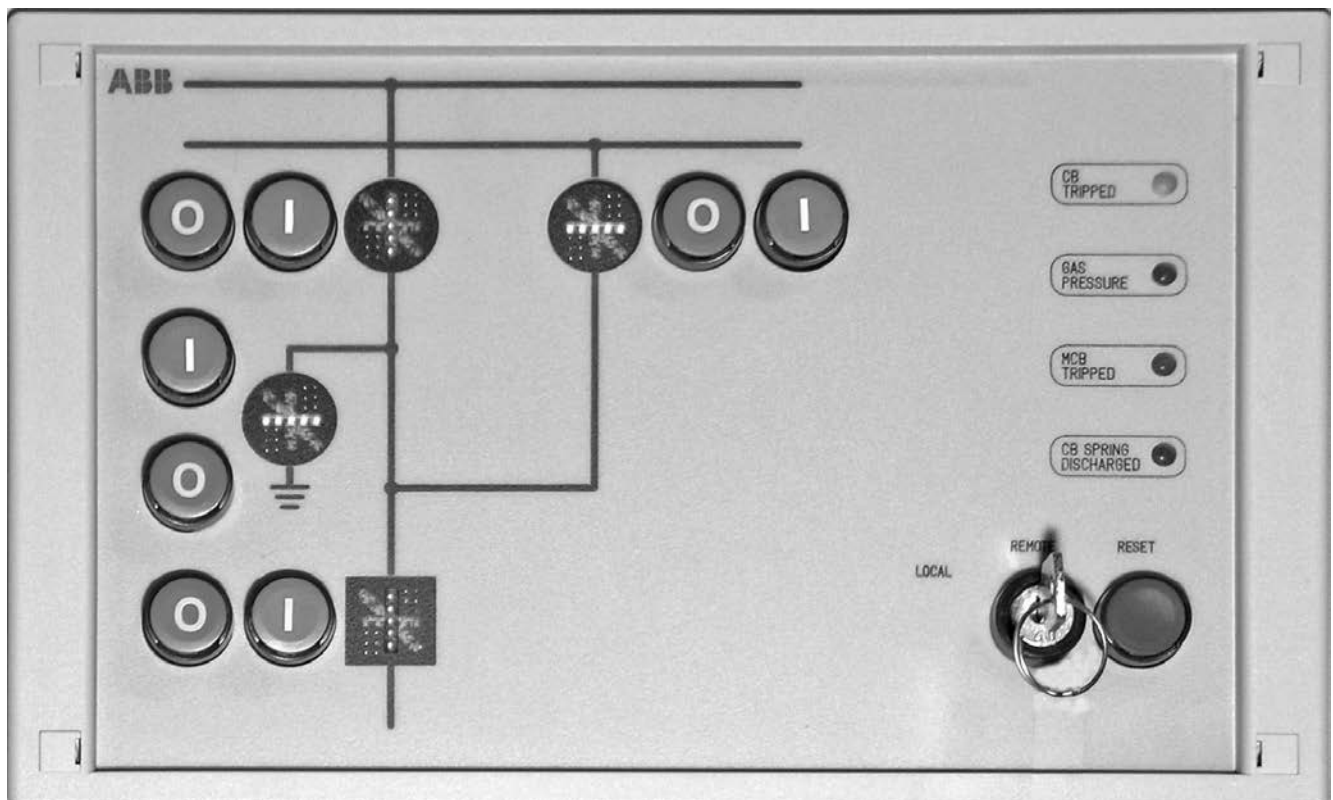

4.4 Emergency manual operation

On failure of auxiliary voltage, the charging motor of a circuit-breaker or the operating mechanism motor of a three position disconnecter or disconnecter, emergency manual operation is as a rule possible.

The operating mechanisms in a panel can be either

- mechanically interlocked, or
- not mechanically interlocked.

In the case of double busbar panels, no uninterrupted change of busbar is possible in emergency manual operation when a mechanical interlock is used, as the interlock prevents simultaneous closing of both disconnecters in an outgoing feeder panel.

Emergency manual operation is performed with the low voltage compartment door open.



Opening of the low voltage compartment door permits intervention in the interlock system

Electrical protection against maloperation is then ineffective.

In the case of panels without mechanical interlocks, there is no protection against maloperation.

Prior to emergency manual operation, switch the mcbs ¹⁾ for the motorized mechanism of the three position disconnecter and the circuit-breaker operating mechanism (release circuit and charging motor) off.

4.4.1 Emergency manual operation of the circuit-breaker

Controls for the circuit-breaker operating mechanism

The front of the operating mechanism (fig. 4.4.1.1) accommodates the mechanical on (1) and off (2) pushbuttons, the receptacle for manual charging of the stored-energy spring (3), the mechanical indicators for “Circuit-breaker ON” “Circuit-breaker OFF” (4), “Stored-energy spring charged”, “Stored-energy spring discharged” (5), an operating cycle counter (6) and the name plate for the circuit-breaker (7).

¹⁾ mcb: miniature circuit breaker

Operation

- Before operating the circuit-breaker, observe the switch position indicator (4) in figure 4.4.1.1.
- On failure of auxiliary voltage, it is possible to open the circuit-breaker using the mechanical OFF button at any time. Closing of the circuit-breaker with the mechanical ON button is dependent on the stored energy spring mechanism being charged. The condition of the stored energy spring mechanism is displayed mechanically (figure 4.4.1.1).
- On failure of auxiliary voltage or the stored energy spring charging motor for the circuit-breaker, the charging process can be carried out or completed manually.
- To do this, insert the charging lever (8 in figure 4.4.1.2) into the receptacle and perform approximately 25 strokes until the charged condition is indicated.
- When the charged condition is reached, the charging mechanism is disengaged, and no further movements of the charging lever can be made.

Circuit-breaker operating mechanism fitted with optional blocking magnet -RLE1

The blocking magnet -RLE1 blocks the mechanical ON button of the circuit-breaker in certain situations. This interlock is active on failure of the supply voltage. Deblocking of the blocking magnet requires work inside the circuit-breaker operating mechanism, and may only be performed by qualified personnel. Please contact the ABB Service Department if required.

Fig. 4.4.1.1: Control side of the circuit-breaker operating mechanism

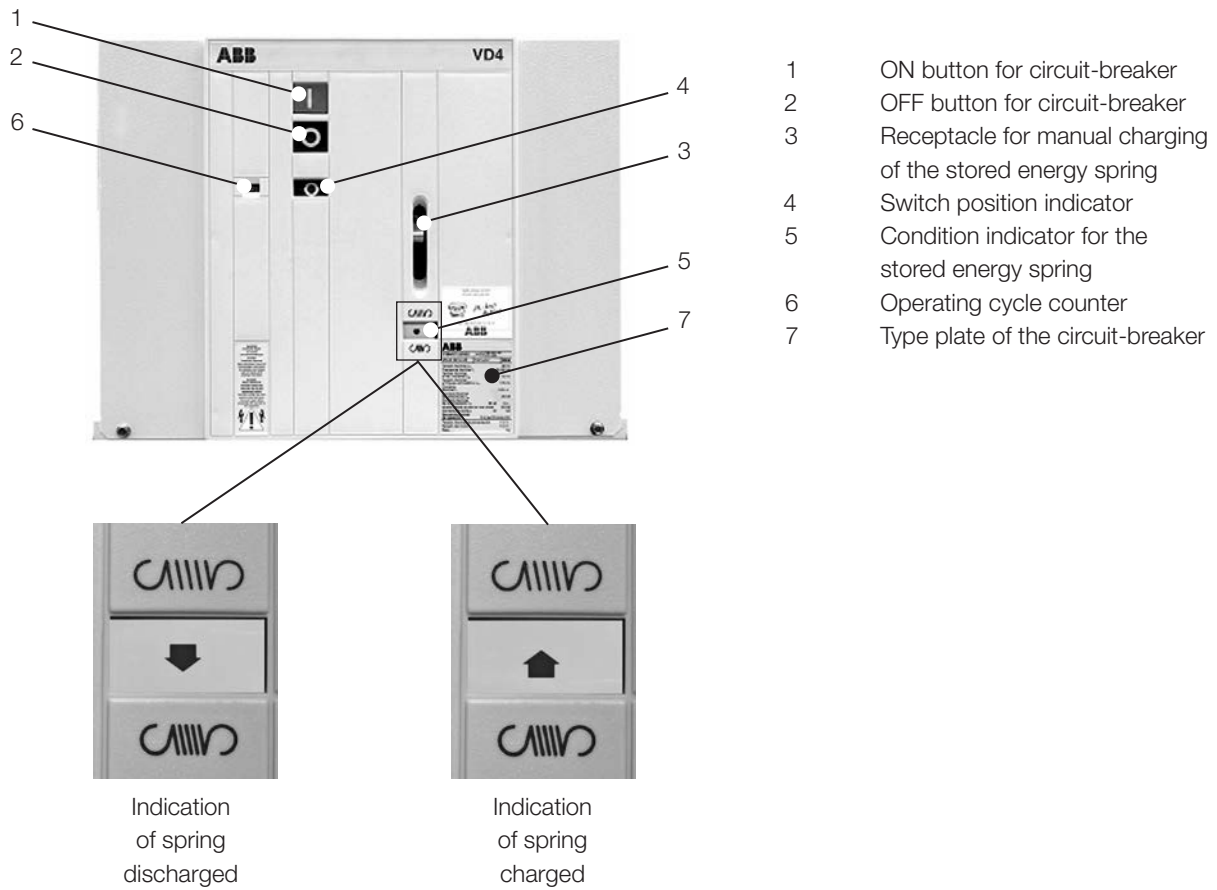
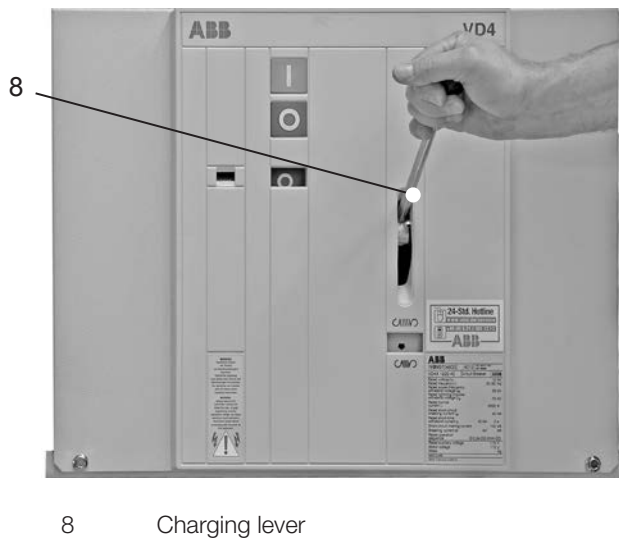

Fig. 4.3.1.2: Manual charging of the stored energy spring



4.4.2 Emergency manual operation of the three-position disconnector and the disconnector

Operator control area of the three-position disconnector mechanism

The operator control area of the three position disconnector operating mechanism (figures 4.4.2.1 and 4.4.2.2) consists of the mechanical switch position indicators ((1) for the earthing switch, (2) for the disconnector), the optional mechanical access lock (3) and the hand crank receptacle (4).

Operator control area of the disconnector mechanism

The operator control area of the disconnector operating mechanism (figure 4.3.2.3) consists of the mechanical switch position indicator (2), the optional mechanical access lock (3) and the hand crank receptacle (4).

Fig. 4.4.2.1: Operator control area of the three position disconnector mechanism with the access lock closed

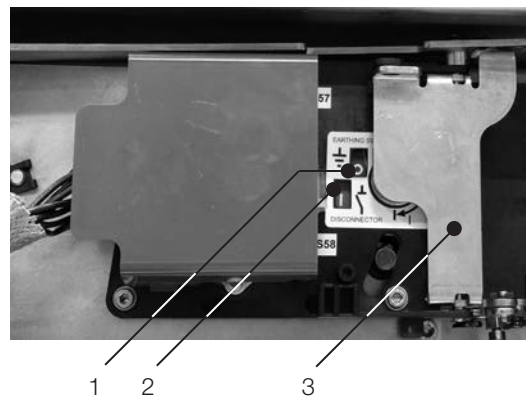

- 1 Switch position indicator for the earthing switch
- 2 Switch position indicator for the disconnector
- 3 Mechanical access lock (optional)

Fig. 4.4.2.2: Operator control area of the three position disconnector mechanism with the access lock open

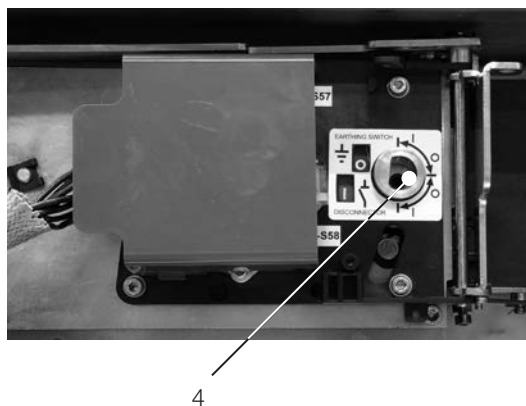

- 4 Hand crank receptacle

Fig. 4.4.2.3: Operator control area of the disconnector mechanism with the access lock open

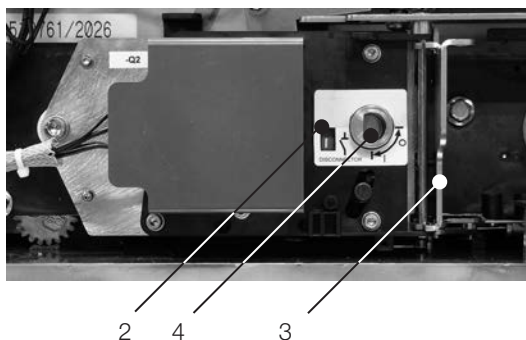

- 2 Switch position indicator
- 3 Mechanical access lock (optional), opened
- 4 Hand crank receptacle

Conditions for operations

- A crank is required for manual operation of the switch (figure 4.4.2.4).
- Observe the switch position indicator before operating the three position disconnector or the disconnector.
- Switch the circuit-breaker in the relevant panel off.
- If fitted: Swing the flap of the mechanical access lock to the right (figure 4.4.2.5). (It is not possible to move the flap when the circuit-breaker is closed.)
- In double busbar systems, when the mechanical access lock is used, the three position disconnector and the disconnector in a panel are interlocked. It is possible to move the flap of one switch when the other switch is in the OFF position..
- Insert the crank into the shaft of the three position disconnector mechanism (figure 4.4.2.6).



Always perform switching operations right up to the stop.

Operation of the three-position disconnector

When using the crank, ensure that pressure is continuously applied via the mushroom handle at the end of the crank throughout the complete switching operation.

Approx. 24 turns of the crank are required from the OFF position of the three position disconnector to the ON position of the earthing switch or disconnector and vice versa.

- **Earthing switch OFF ⇒ ON**
 - To close the earthing switch, turn the crank counter-clockwise until the stop is reached.
 - Withdraw the crank.
 - Close the flap of the mechanical access lock, if fitted.
- **Disconnector OFF ⇒ ON**
 - To close the disconnector, turn the crank clockwise until the stop is reached.
 - Withdraw the crank.
 - Close the flap of the mechanical access lock, if fitted.

Fig. 4.4.2.4: Crank for emergency manual operation of the three-position disconnector and the disconnector

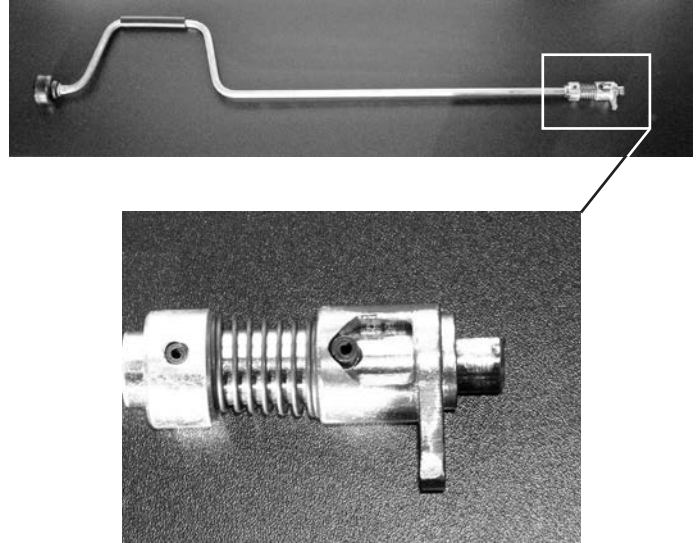

Fig. 4.4.2.5: Opening the flap of the mechanical access lock

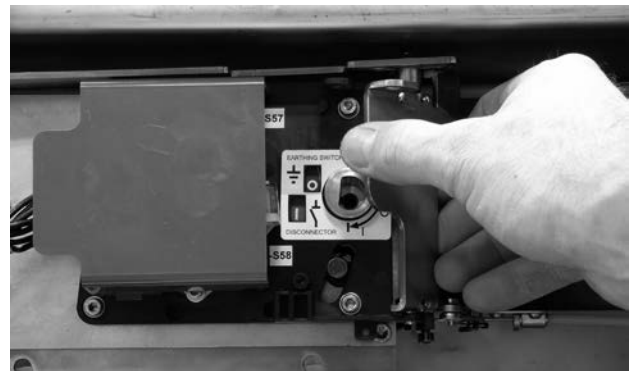
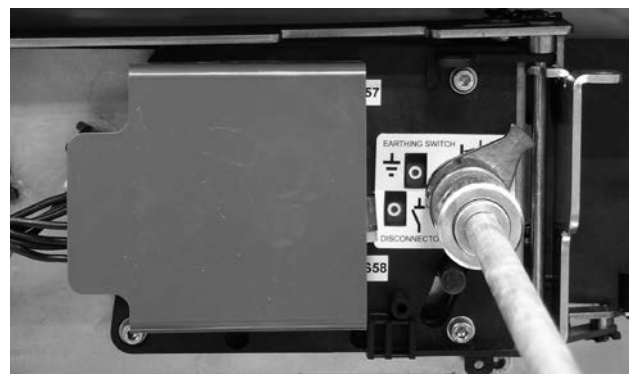

Fig. 4.4.2.6: Inserting the crank into the shaft of the operating mechanism



– **Earthing switch ON ⇒ OFF ⇒ disconnector ON**

- Turn the crank clockwise until the stop is reached.
- The three-position disconnector is then in the OFF position.
- Withdraw the crank and reinsert it. Turn the crank clockwise until the stop is reached.
- Withdraw the crank.
- Close the flap of the mechanical access lock, if fitted.

– **Disconnecter ON ⇒ OFF ⇒ earthing switch ON**

- Turn the crank counter-clockwise until the stop is reached.
- The three-position disconnector is then in the OFF position.
- Withdraw the crank and reinsert it. Turn the crank counter-clockwise until the stop is reached.
- Withdraw the crank.
- Close the flap of the mechanical access lock, if fitted.

Operation of the disconnector

- Approx. 24 turns of the crank are required from the OFF position to the ON position of the disconnector and vice versa.

– **Disconnecter OFF ⇒ ON**

- To close the disconnector, turn the crank clockwise until the stop is reached.
- Withdraw the crank.
- Close the flap of the mechanical access lock, if fitted.

– **Disconnecter ON ⇒ OFF**

- Turn the crank counter-clockwise until the stop is reached.
- Withdraw the crank.
- Close the flap of the mechanical access lock, if fitted.

Equipping of the three position disconnector and disconnector with blocking magnet -RLE1

When a mechanical access lock (figure 4.4.2.1) is used, the three position disconnector and the disconnector can be fitted with a blocking magnet -RLE1. In certain situations, the blocking magnet prevents the devices from being operated. On failure of auxiliary voltage, the blocking magnet permanently prevents the access lock from being opened. Deblocking of the blocking magnet requires work on the operating mechanism and may only be performed by qualified personnel. Please contact the ABB Service Department if required.

4.5 Gas monitoring with density sensors

The high voltage compartments must have a sufficient insulating gas pressure during operation (please see the table entitled “Technical data” for the pressures). The density of the SF₆ insulating gas is monitored during operation by a density sensor (temperature-compensated).

If the gas pressure falls below the level for a warning signal, a signal indicating that the insulating gas should be topped up is issued via an LED on a bay control unit or via a warning lamp.

When a switchgear is isolated for a relatively long period, the auxiliary power supply is to be maintained in order to monitor the insulating gas density.

4.6 Operation of the isolating device for voltage transformers

The voltage transformers in the metering panel, the optional voltage transformers in the 600 mm wide panel with outer cones and the voltage transformers for the integrated metering system with isolating device can be isolated manually from the corresponding switchgear section. Cross-sections of these panels showing the positions of the controls can be found in fig. 4.6.1.



The isolating devices in the metering panel and in the panel with outer cones may only be operated when the switchgear section concerned is in the off-circuit condition.

Fig. 4.6.1: A) Position of the controls for the voltage transformer isolating device

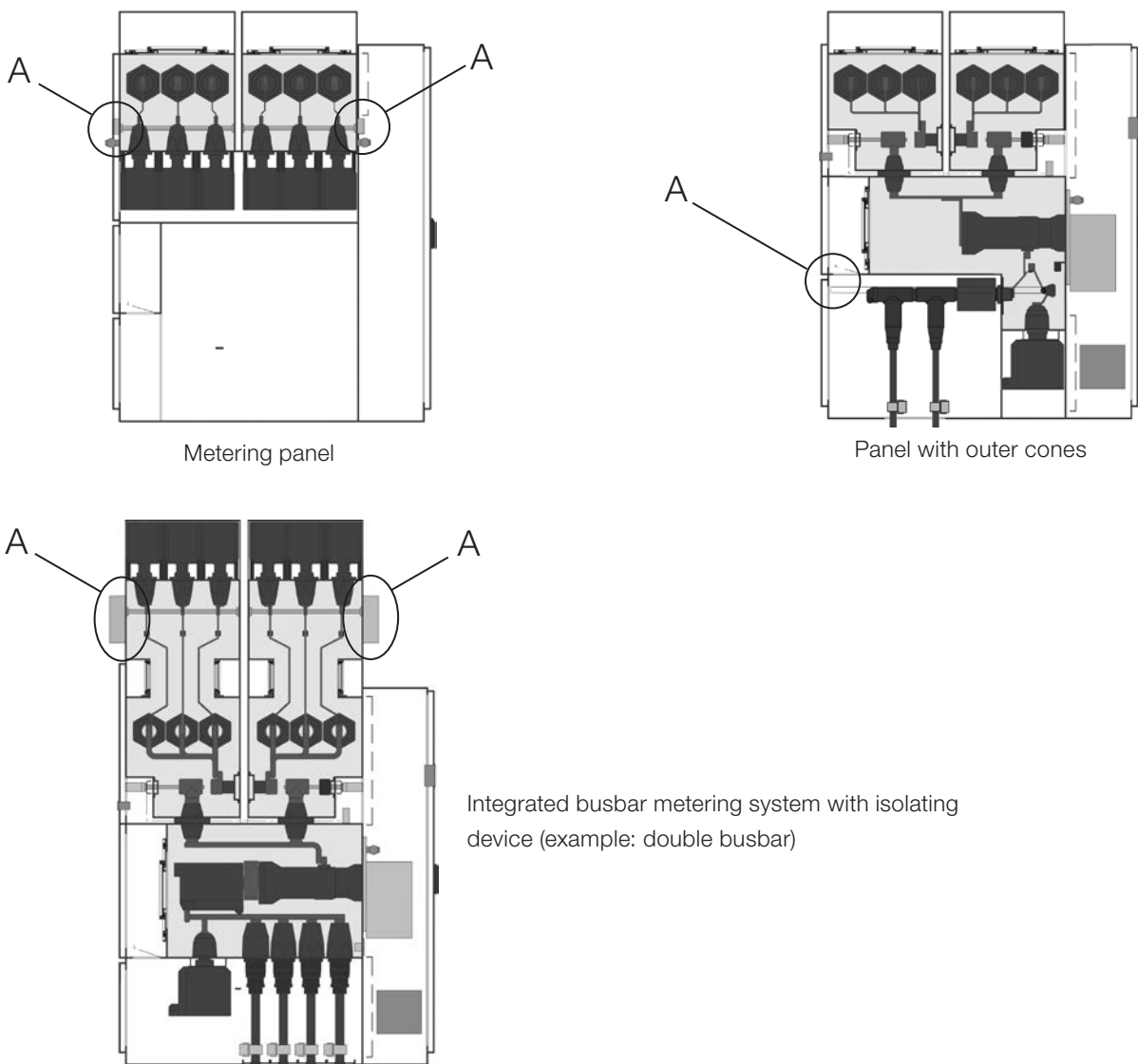

4.6.1 Operation of the isolating device for voltage transformers in metering panels

The controls and displays for the voltage transformer isolating device can be found behind the flap. Observe warning label (7). Check the switch position indicator (6).

Earthing the voltage transformers

To earth the voltage transformers, pull out the lock knob (3) and turn the operating lever (4) with a key (see accessories) counter-clockwise as shown on the direction of rotation indicator (4). Release the lock knob. Turn the operating lever counter-clockwise until the lock knob engages in the limit position of the isolating device.



When the lock knob engages in the limit position, the dielectric strength of the isolating device is ensured.

Close flap (2) and secure the isolating device with a padlock.

Connecting the voltage transformers

To connect the voltage transformers, pull out the lock knob (3) and turn the operating lever (4) with a key (see accessories) clockwise as shown on the direction of rotation indicator (4). Release the lock knob. Turn the operating lever clockwise until the lock knob engages in the limit position of the isolating device.



When the lock knob engages in the limit position, the current carrying capacity of the isolating device is ensured.

Close flap (2) and secure the isolating device with a padlock.



Isolate the relevant switchgear section before connecting or disconnecting voltage transformers.

- Comply with the safety regulations to EN 50110.
- Check the switchgear section for the off-circuit condition as described in section 5.1.
- Earth the switchgear section and secure the working area in accordance with section 4 and EN 50110 standard.
- Switch the mcbs ¹⁾ of the relevant operating mechanisms off in order to prevent the switchgear section being energized by remote control.

The device for isolation of the voltage transformers (figure 4.6.1.1) for measurement of the front busbar is located in the low voltage compartment. Operation of the isolating device for the voltage transformers on the rear busbar is effected from the rear of the panel. Operation is identical in both cases.

The isolating device can be secured with a padlock. Remove the padlock prior to operation. Swing flap (2) to the left.

Fig. 4.6.1.1: Controls and displays for the voltage transformer isolating device with flap (2) opened

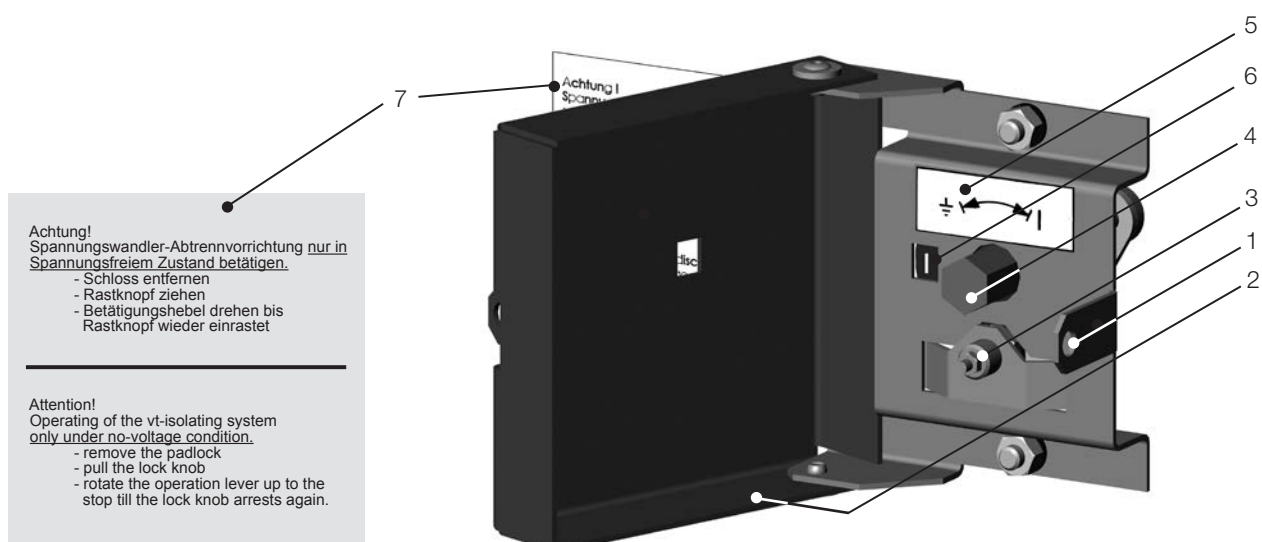

- 1 Bar for padlock
- 2 Flap
- 3 Lock knob
- 4 Operating lever (hexagon 17 mm AF)

- 5 Direction of rotation indicator
- 6 Switch position indicator
- 7 Warning sign

4.6.2 Operation of the isolating device for voltage transformers in panels with outer cones



Isolate the relevant switchgear section before connecting or disconnecting voltage transformers.

- Comply with the safety regulations to EN 50110.
- Check the switchgear section for the off-circuit condition as described in section 5.1.
- Earth the switchgear section and secure the working area in accordance with section 4 and EN 50110 standard.
- Switch the mcbs ¹⁾ of the relevant operating mechanisms off in order to prevent the switchgear section being energized by remote control.

The operating mechanism for the voltage transformer isolating device is located in the cable termination compartment on the right-hand side wall (figure 4.6.1).

Dismantle the cover on the cable termination compartment. This is done by removing the two screws above the cover and pulling the cover upwards.

The controls and indicators for the voltage transformer isolating device are shown in figure 4.6.2.1. Check the switch position indicator (5 and 6). The isolating device can be secured with a padlock (3). Remove the padlock before operating the device.

Fig. 4.6.2.1: Controls and displays for the voltage transformer isolating device

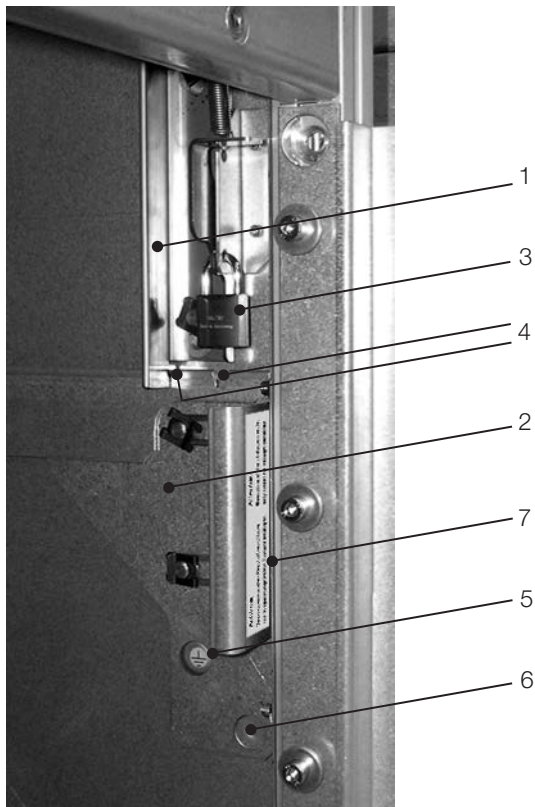

Achtung	Attention
Spannungswandler-Abschaltvorrichtung	Operating of the vt-disconnector
nur in spannungsfreiem Zustand betätigen	only under no-voltage condition

- 1 Locking plate
- 2 Actuating plate
- 3 Padlock (optional)
- 4 Latching slot
- 5 Switch position indicator, "voltage transformer earthed"
- 6 Opening for switch position indicator, "voltage transformer connected"
- 7 Instruction label

Earthing the voltage transformers

To earth the voltage transformers, slide the locking plate (1) upwards and pull the actuating plate (2) to the front until the stop is reached. Allow the locking plate to slide into the appropriate latching slot (4) in the actuating plate.



When the locking plate engages in the latching slot of the actuating plate, the dielectric strength of the isolating device is ensured.

Secure the isolating device with a padlock.

Connecting the voltage transformers

To connect the voltage transformers, slide the locking plate (1) upwards and pull the actuating plate (2) to the rear until the stop is reached. Allow the locking plate to slide into the appropriate latching slot (4) in the actuating plate.



When the locking plate engages in the latching slot of the actuating plate, the current carrying capacity of the isolating device is ensured.

Secure the isolating device with a padlock.

Fig. 4.6.2.2: Operation of the voltage transformer isolating device



4.6.3 Operation of the isolating device for integrated metering



Switching is performed by means of an isolating device (fig. 4.6.3.1) which is loaded immediately before switching and released by pulling the knob (4). The knob may only be pulled when the mechanism is in position A or B. Maloperation is prevented by a pawl (6). Do not override the blocking function of the pawl by using too much force!

As a snap-action mechanism is used, the isolating device can also be operated when the busbar is live.

As a snap-action mechanism is used, the isolating device can also be operated when the busbar is live.

The device for operation of the voltage transformers for measurement of the front busbar (fig. 4.6.3.1) is located above the low voltage compartment. The device for operation of the voltage transformers for the rear busbar is accessible from the rear of the panel. Both devices are operated identically.

The isolating device can be secured with a padlock. Remove the padlock and swing flap (2) to the left.

The controls and displays for the voltage transformers are located behind the flap. Observe the instruction label inside the flap. Check the switch position indicator (5).

Earthing the voltage transformers (fig. 4.6.3.1)

- Pull lever (3) down in the direction of the arrow and move it to the right. Allow the lever to engage in the limit position. The mechanism is then loaded.
- Pull lever (3) down in the direction of the arrow and move it to the right. Allow the lever to engage in the limit position. The mechanism is then loaded.
- Leave lever (3) in the right-hand position.

Connecting the voltage transformers (fig. 4.6.3.1)

- Pull lever (3) down and move it to the left (in the opposite direction to the arrow). Allow the lever to engage in the limit position. The mechanism is then loaded.
- Pull button (4) to release the mechanism and change the switch position from “Earthed” to “ON”. The voltage transformers are then connected to the busbar as shown by switch position indicator (5).
- Leave lever (3) in the left-hand position.

Fasten the flap with the padlock. (The flap cannot be closed when the lever is not in position A or B.)

Fig. 4.6.3.1: Voltage transformer isolating device for the integrated metering system

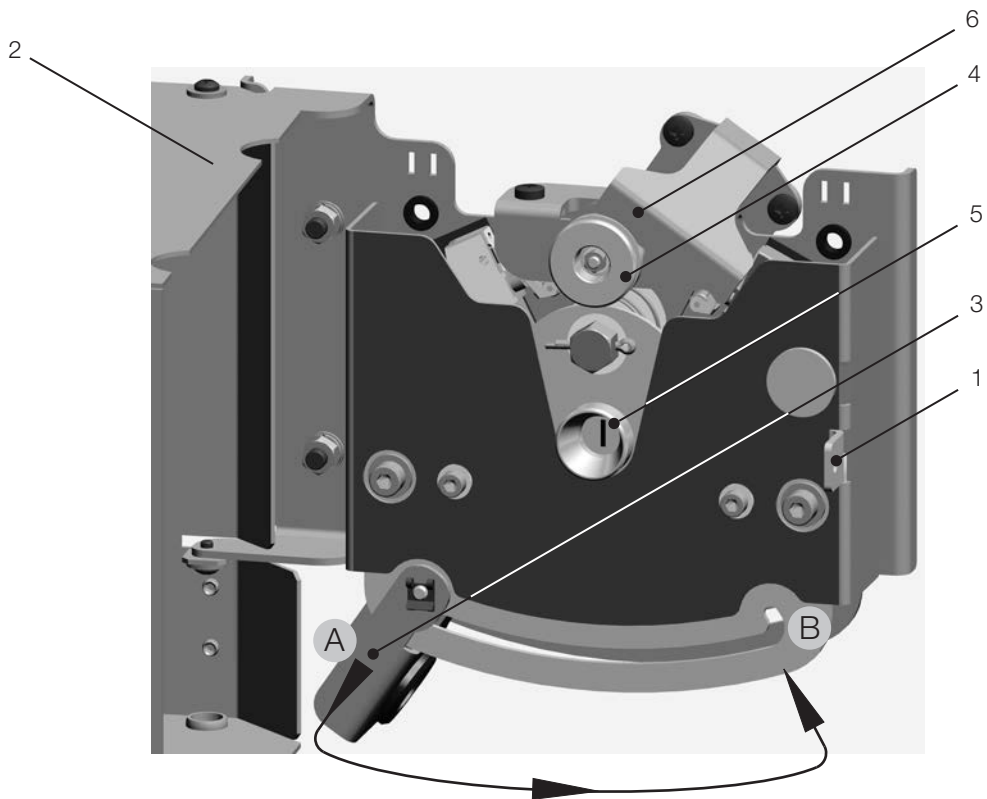

Instruction label inside the flap

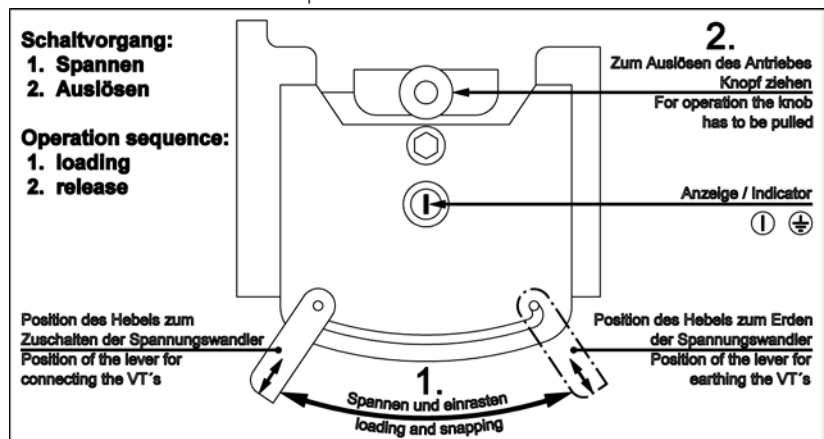

Position **A** : Position for connecting the voltage transformers

Position **B** : Position for earthing the voltage transformers

- 1 Latch for padlock
- 2 Flap
- 3 Lever
- 4 Knob
- 5 Switch position indicator

5 Test procedures

5.1 Testing for the off-circuit condition

The off-circuit condition on the cable side is tested by means of the capacitive voltage indicator (pick-off on the outer cone). Three systems can be used:

- LRM system,
- KVDS system or
- CAVIN system.



Observe the instruction manual for the system used.

- Check the function of the equipment immediately before use. The optical display must be clearly visible!
- The sockets of the capacitive indicator system must never be short-circuited, except during voltage testing on the switchgear.

5.1.1 LRM system

Testing for the off-circuit condition is performed with a plug-in display unit (design to IEC 61243-5) at the three pairs of measuring sockets.



Perform repeat tests on the system in accordance with IEC 61243-5, for instance with interface tester KSP. Observe the instructions for the interface tester.

5.1.2 KVDS and CAVIN system

Testing for the off-circuit condition is performed with the display on the unit. No separate display unit is required.

Fig. 5.1.1.1: LRM system with display unit



Fig. 5.1.2.1: KVDS system



Fig. 5.1.2.2: CAVIN system

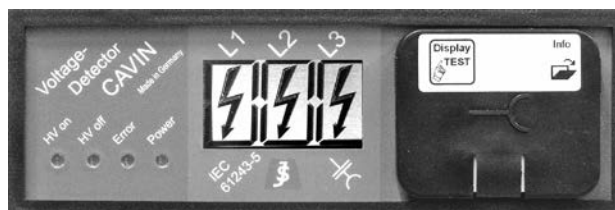

5.2 Testing for the in-phase condition

Testing for the in-phase condition, e.g. when there is more than one incoming feeder, can be performed with a suitable phase comparator at the measuring sockets of the capacitive voltage indication system.

The phase comparator must comply with IEC 61243-5 and correspond to the technical design of the indicator system used.



Observe the instruction manual for the phase comparator.

5.3 High voltage tests

Panels with inner cone

The test voltage is applied via the test socket on the panel (inner cone, size 2).

Panels with outer cone

Direct access to the conductors via the fitted cable connectors is available for the performance of high voltage tests. The test voltage is applied through suitable test sets for the outer cone plug system used.

5.3.1 Cable tests with DC-voltage



Do not exceed the maximum test voltages and the maximum test duration as specified in IEC 60502-2.



Comply with the safety regulations to EN 50110.

- Isolate the panel whose cables are to be tested in accordance with section 4.
 - Test the outgoing feeder for the off-circuit condition as described in section 5.1.
 - Earth the outgoing feeder and secure the working area in accordance with section 4 and EN 50110 standard.
 - Switch the mcbs ¹⁾ of the relevant operating mechanisms off in order to prevent the outgoing feeder being energized by remote control.
- Dismantle the cover on the relevant cable termination compartment.
- Dismantle plugged-in transformers in the relevant outgoing feeder as described in section 2.3.6 or remove the blanking plugs from the test sockets.
 - Close off any free cable sockets with blanking plugs.
 - Dismantle any surge arresters in the relevant outgoing feeder in accordance with the manufacturer's instructions.



Short-circuit the sockets for the capacitive indicator system in the outgoing feeder using the short-circuiting plug.



Short-circuit the cores of the current transformers concerned which are located in gas compartments and earth them.

Panel with inner cone sockets

- Fit test plugs or test cables to test sockets of the panel.

Panel with outer cones

- Fit the high voltage testing set to the (outer cone) plug system of the panel in accordance with the manufacturer's instructions.

Test sequence

- Establish the test circuit in accordance with the manufacturer's directions for the test apparatus.
- Cancel the earthing of the system section to be tested before applying the test voltage by opening the circuit-breaker.
- Perform the cable test in accordance with the manufacturer's directions for the test apparatus.
- Earth the system section on completion of individual tests and on conclusion of testing by closing the circuit-breaker.
- Dismantle the test cables or test plugs.
- Refit any dismantled surge arresters and voltage transformers.
- Close off any free test sockets and cable sockets with blanking plugs.
- Close off free outer cones with insulating blanking plugs in accordance with the manufacturer's instructions.
- Remove the short-circuiting bridges and the earthing connection from the secondary terminals of the current transformers.
- Remove the short-circuiting plugs from the capacitive indicator.
- Refit the cover on the cable termination compartment.

¹⁾ mcb: miniature circuit breaker

5.3.2 Voltage test of the main circuit

In the course of testing, the test voltage is applied in sequence to every conductor in the main circuit, with the other conductors earthed. Do not exceed the test voltage levels (80 % of the rated short-duration power frequency withstand voltage (U_D) as shown on the type plate). Comply with the test conditions as set out in IEC 62271-200.



In the case of a sectionaliser (without circuit-breaker), application of the test voltage to the busbar in operation is not permissible. Earth the system section concerned for the duration of the test (figure 5.3.2.1).

Fig. 5.3.2.1: Voltage test in case of a sectionaliser (without circuit-breaker)

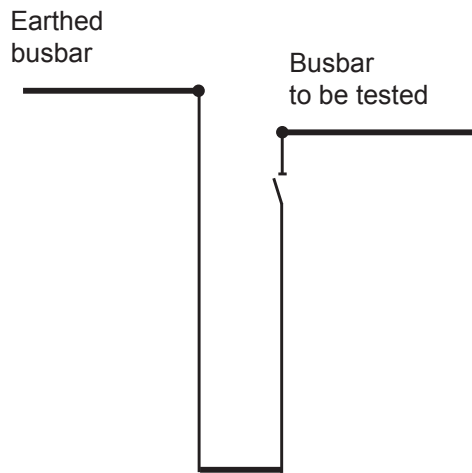

Comply with the safety regulations to EN 50110.

- Isolate the section to be tested in accordance with section 4.
- Test the switchgear sections for the off-circuit condition as described in section 5.1.
- Earth the section to be tested and secure the working area in accordance with EN 50110 standard.
- Switch the mcbs ¹⁾ of the relevant operating mechanisms off in order to prevent the switchgear section being energized by remote control.



If there are busbar metering panels within the system section to be tested, isolate the relevant voltage transformers in the metering panels by operating the isolating device (see section 4.5).



Dismantle plugged-in voltage transformers within the system section to be tested (see section 2.3.6).



Dismantle any surge arresters within the system section to be tested in accordance with the manufacturer's instructions.



Close off free (inner cone) sockets within the system section to be tested with insulating blanking plugs.



Close off free outer cones within the system section to be tested with insulating blanking plugs in accordance with the manufacturer's instructions.



Short-circuit the sockets for the capacitive indicator of the relevant system section with the short-circuiting plug.



Short-circuit the cores of the current transformers concerned which are located in gas compartments and earth them.

Application of test voltage via a panel with inner cone sockets

- Fit test plugs or test cables to test sockets or free cable sockets in the panel to which the test voltage is to be applied.

Application of test voltage via a panel with outer cones

- Fit the high voltage testing set to the (outer cone) plug system of the panel to which the test voltage is to be applied, in accordance with the manufacturer's instructions.

¹⁾ mcb: miniature circuit breaker

Test sequence

- Connect the test transformer to the test plug or test cable and earth the other two phases of the main circuit.
- Connect the second terminal of the test transformer to system earth.
- Connect other sections of the switchgear to be tested by operating the relevant disconnectors and circuit-breakers.
- Cancel the earthing of the system section to be tested before applying the test voltage.
- Perform the high voltage test.
- Earth the system section on completion of individual tests and on conclusion of testing.
- Dismantle the test cables or test plugs.
- Fit any surge arresters and voltage transformers required.
- Close off any free test sockets and cable sockets with blanking plugs.
- Close off free outer cones with insulating blanking plugs in accordance with the manufacturer's instructions.
- Cancel any isolation of voltage transformers in metering panels.
- Remove the short-circuiting plugs from the capacitive indicator.
- Refit the cover on the cable termination compartment.

5.4 Secondary protection testing



Comply with the safety regulations to EN 50110.

- Isolate the feeder panel to be tested in accordance with section 4.
- Test the switchgear section for the off-circuit condition as described in section 5.1.
- Earth the outgoing feeder and secure the working area in accordance with section 4 and EN 50110 standard.
- Switch the mcbs ¹⁾ of the relevant operating mechanisms off in order to prevent the outgoing feeder being energized by remote control.



Voltage may only be applied to the OFF release coil of the circuit-breaker (shunt release OFF) for a period of 1000 ms. If this time is exceeded the coil will burn out. For this reason, the protection testing system must be shut down by the OFF command, or the shunt release OFF must be disconnected.



If the circuit-breaker is also to be tested, please note that earthing via the circuit-breaker is cancelled when the breaker is opened. Otherwise, disconnect the release coil before testing.



Note that when the voltage signals from the voltage transformers in the panel to be tested are used by other panels, the signals are not available during the work. This can lead to impairments of function in the other panels.

- Establish the test circuit in accordance with the protection tester manufacturer's directions and perform the test.

¹⁾ mcb: miniature circuit breaker

5.5 Protection testing by primary current injection



Comply with the safety regulations to EN 50110.

- Isolate the relevant switchgear section in accordance with section 4.
- Test the switchgear section for the off-circuit condition as described in section 5.1.
- Earth the switchgear section and secure the working area in accordance with section 4 and EN 50110 standard.
- Switch the mcbs ¹⁾ of the relevant operating mechanisms off in order to prevent the switchgear section being energized by remote control.



If the circuit-breaker is also to be tested, please note that earthing via the circuit-breaker is cancelled when the breaker is opened. Otherwise, disconnect the release coil before testing.



Note that when the voltage signals from the voltage transformers in the panel to be tested are used by other panels, the signals are not available during the work. This can lead to impairments of function in the other panels.



Do not exceed the maximum values for the current testing plug (see the section on accessories).

- Observe the examples of primary side test circuits in figures 5.5.1 and 5.5.2.

Fig. 5.5.1: Panel with inner cone, test transformer connected to the test socket via a current testing plug, current flow via the current transformer and circuit-breaker to the earthing contact of the three-position disconnector.

Fig. 5.5.2: Panel with outer cone, test transformer connected to the cable connector via suitable test leads, current flow via the current transformer and circuit-breaker to the earthing contact of the three-position disconnector.

Test transformer

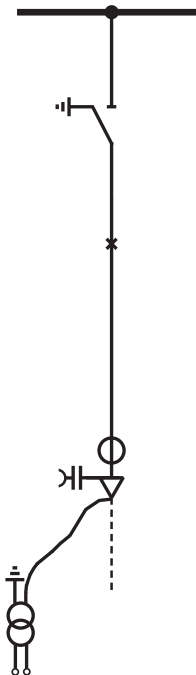
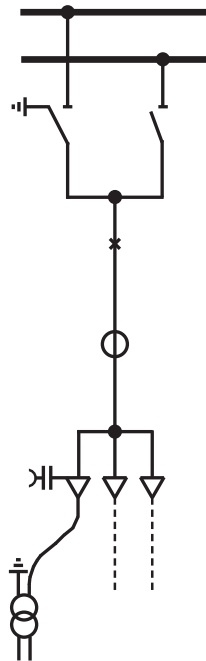

¹⁾ mcb: miniature circuit breaker

Panels with inner cone

Direct access to the conductors for performance of protection tests by primary current injection is possible via current testing plugs which are fitted to the test sockets of the panel.

- Dismantle the cover on the cable termination compartment of the relevant panel.
- Dismantle any voltage transformers fitted as described in section 2.3.6, and also any surge arresters or blanking plugs on the test sockets of the relevant outgoing feeder.
- Clean the current testing plug.
- Insert the current testing plugs into the test sockets and screw the plugs to the sockets.
- Establish the test configuration in accordance with the manufacturer's instructions for the protection testing equipment and perform the protection test.
- Earth the switchgear section after completion of the test.
- Immediately on completion of testing, remove the current testing plugs and replace them with the intended devices (voltage transformers, surge arresters or blanking plugs).
- Refit the cover on the cable termination compartment.

Panels with outer cone

Direct access to the conductors for performance of protection tests by primary current injection is possible via the fitted cable connectors. The test current is applied via suitable testing sets for the cable connector system used.

- Dismantle the cover on the cable termination compartment of the relevant panel.
- Fit the testing set in accordance with the manufacturer's instructions.
- Establish the test configuration in accordance with the manufacturer's instructions for the protection testing equipment and perform the protection test.
- Earth the switchgear section after completion of the test.
- Remove the testing set.
- Refit the insulating ends of the cable connectors in accordance with the manufacturer's instructions.
- Refit the cover on the cable termination compartment.

6 Service

6.1 Inspection and maintenance of the switchgear

- Check that the switchgear room and the switchgear are in proper condition for the intended use at regular intervals.
- Check primarily for dirt, corrosion and moisture.



If you find that the switchgear is not in the proper condition, take appropriate action, e.g. cleaning of the switchgear, removal of corrosion or rectification of the cause of the moisture.

6.2 Inspection and servicing of individual components

Please consult the relevant directions and instruction manuals for the actions and intervals required.

All parts in SF₆ are maintenance-free.

The three position disconnecter is maintenance-free for 2000 operating cycles, and the disconnecter for 1000 operating cycles.

6.3 Checking the dimensional accuracy of the control wire settings

When a mechanical interlock is fitted (optional), check the play on the control wires on the circuit-breaker operating mechanism in the course of an inspection.

The mounting for the control wires of the mechanical interlock is located above the circuit-breaker operating mechanism (figure 6.3.1).

When the access interlock for the three-position disconnect mechanism (figure 6.3.2) is opened, the slide must be directly operated by the control wire. If this is not the case, use the control wire nipple to adjust the control wire so that there is no play with the flap closed.

6.4 Outlet filter

Low voltage compartments with operating currents > 2000 A are fitted with outlet filters. The outlet filters are located on the roof plates of the low voltage compartments. Replace the filter mats when required.

Draw the louvred grating off by gripping the recesses at the bottom end of the filter. Replace the filter mat and snap the louvred grating back into position.

Fig. 6.3.1: Mounting for the control wire above the circuit-breaker operating mechanism when a mechanical interlock is fitted

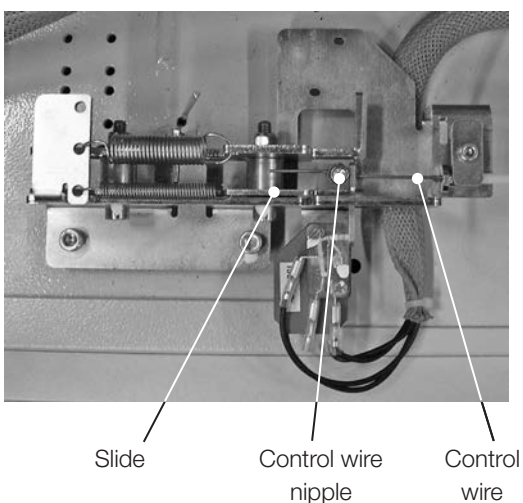

7 Actions at the end of the service life

ABB can be appointed to decommission and dismantle the switchgear. The switchgear is then professionally dismantled by ABB and the SF₆, which is normally reusable, removed before the switchgear is broken down into its remaining components.

Further notes on decommissioning at the end of the switchgear's service life can be found in materials supplement BA 509 E.

Fig. 6.3.2: Mechanical access interlock on the three-position disconnect mechanism

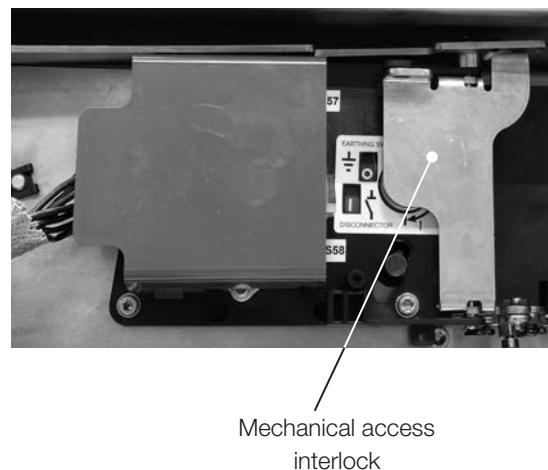

8 List of tools

The tools required for assembly of the switchgear system are detailed in the list below. Tools are not part of the ABB scope of supply.

All the tools listed must comply with the safety regulations of the country concerned.

- 1 Temperature-compensated pressure gauge with coupling (ABB part number GCE0905091P0101) (figure 2.3.1.1.3)
- 1 Set of open-ended spanners, 8 to 19 mm AF
- 1 Set of ring spanners, 8 to 19 mm AF
- 1 Ratchet, 3/8", with extensions and 8 to 19 mm AF socket keys and 4 to 10 mm Allen key inserts
- 1 Ratchet, 1/2", with extensions and 10 to 19 mm AF socket keys and 4 to 10 mm Allen key inserts
- 1 Set of screwdrivers for slotted and cross-head screws, sizes 1 to 3
- 1 Set of electrician's pliers (end cutting nipper, pointed pliers, flat end pliers, stripping tongs)
- 1 Rubber mallet
- 1 Set of fitter's hammers
- 1 Leveller
- 1 Plumb bob
- 1 Guide string
- 1 Scribing iron
- 1 Punch
- 1 Tri-square
- 1 Tape measure
- 1 Calliper gauge
- 1 Continuity tester
- 1 Multimeter (voltage, current and resistance)
- 1 Torque wrench, 0 – 40 Nm, calibrated
- 1 Torque wrench, 15 – 100 Nm, calibrated
- 1 Extension cable, 230 V, 15 m long
- 1 Cable drum, 230 V / 16 A, 50 m
- 1 Angle grinder, small
- 1 Hand-held drill, chuck up to 13 mm
- 1 Hammer drill
- 1 Welding machine + accessories
- 1 Set of steel drill bits, 1 to 13 mm
- 1 Set of concrete drill bits, 6 to 12 mm
- 1 Steps, 8 rung
- 2 Trolley jacks (recommended capacity 2 t) or
- 2 Hydraulic lift trolleys (recommended capacity 3.5 t per pair)
- 4 Lifting ropes, 0.75 m, recommended capacity 1 t
- 4 Lifting ropes, 1.5 m, recommended capacity 1 t
- 4 Shackles, capacity 1 t
- 2 Pinch bars
- 5 Handling tubes
- 2 Chain hoists, 0.25 t including chain
- 1 Site lighting
- 1 Torch
- 1 Hand-held lamp
- 1 Vacuum cleaner
- Several wooden planks
- Several wooden beams
- Soft, non-fraying cleaning cloth
- Household cleaner, chlorine-free

9 Working materials, auxiliary materials and accessories

Working materials, auxiliary materials and accessories are included in the scope of supply as contracted.

9.1 Working materials

	ABB part number
SF ₆ insulating gas	
Pressure-liquefied gas in steel cylinders, Capacity: 5 kg	GCE0990258P0102
Capacity: 40 kg	GCE0990253P0102
– Quality to IEC 60376	



Observe sample instruction manual included in manual HB 605/E.

As a rule, the gas compartments of the panels are filled with insulating gas at the works. For this reason, no gas cylinders are supplied with the switchgear. Gas cylinders are not normally part of the ABB scope of supply.

In the case of airfreight, the gas compartments of the panels are filled at the works to a reduced insulating gas pressure, and therefore they have to be topped up with SF₆ at site. In this case SF₆ in cylinders is required. Further information on the handling of SF₆ can be found in instruction manual HB 605/E.

If extreme temperatures ≥ 50 °C during the storage, transport or temporary storage in the open air of the SF₆ cylinders with exposure to sunlight cannot be ruled out, please provide in your order for a reduced filling factor of 0.75 kg/l for safety reasons.

Filter mats for outlet filters (panels > 2000 A)	GCE0995402P0100
--	-----------------

9.2 Auxiliary materials

	ABB part number
Lubricant: Isoflex Topas NB 52, capacity 1 kg	GCE0007249P0100
Assembly paste for silicone insulating parts, capacity 40 g	1VB0000207P0100
Cleaning agent for silicone insulating parts, busbar sockets, outer cones and fuse sealing collars Intensive cleaner M.X.T. 60 forte, capacity 1 l	1VB0000240P0100
Silicone paste for greasing of o-rings, capacity 250 g	GCE0009048P0102
Paint, standard color RAL 7035, Can, capacity 1 kg	GCE9014060R0103

9.3 Accessories

ABB part number

Accessories for manual charging of the stored energy spring of the circuit-breaker

Charging lever for VD4 X operating mechanism (figure 4.3.1.2) GCE9477394R0101

Accessories for emergency manual operation of the three-position disconnecter and the disconnecter

Crank for emergency manual operation, length: 795 mm (standard, figure 4.3.2.4) GCE7006002R0103
Crank for emergency manual operation, length: 1209 mm GCE7006002R0102

Accessories for operation of the isolating device in metering panels

Key for isolating device, hex. 17/350 1VB0000038P0100

Accessories for the voltage transformer truck

Crank (figure 2.3.6.3.1) GCE8008184P0101

Testing accessories

Voltage testing plug up to 36 kV for inner cone, size 2 GCE0920226P0101
Voltage testing plug up to 36 kV for inner cone, size 3 GCE0920226P0102
Voltage testing cable up to 36 kV for inner cone, size 2 GCE0920226P0105
Voltage testing cable up to 36 kV for inner cone, size 3 GCE0920226P0106
Current testing plug for inner cone, size 2, $I_N = 800$ A, $I_p = 2500$ A / 4 min. GCE0920226P0103
Current testing plug for inner cone, size 3, $I_N = 1250$ A, $I_p = 3150$ A / 4 min. GCE0920226P0104

Blanking plugs

Blanking plug for inner cone, size 2 GCE8011949R0101
Blanking plug for inner cone, size 3 GCE0909097P0100

Accessories for visible earthing by earthing set

Earthing set for inner cone, size 2, 29.5 kA GCE0920226P0107
Earthing set for inner cone, size 3, 29.5 kA GCE0920226P0108
Rod for earthing set, hinged GCE0920226P0109
Wall mounting for earthing set 1VB0000074P0100

Accessories for capacitive indicator, system LRM

Display unit (figure 5.1.1.1) GCE0931333P0101
Interface tester GCE0900052P0102
Short-circuiting plug GCE0909005P0101

Other accessories

Lifting section for fork lift truck (figures 1.4.1.1, 1.4.1.2) GCE9015358R0102
Double bit key for barrel lock in panel door GCE0990108P0100
Wall mounting for accessories 1VB8000533P0101
Adapter between filling valve of panel module and the hose connection of a DILO filter truck (see manual HB 605/E) 1VB8000532R0101

10 Technical data

The technical data of the switchgear can be found on the name plate. The name plate of the panel is located at the top on the right-hand side wall of the opened low voltage compartment. Further type plates for individual components can be found in the immediate vicinity of the devices concerned.

Table 10.1: Technical data of the panels

Rated voltage / maximum operating voltage ¹⁾	U_r	kV	12	24	36
Rated power-frequency withstand voltage ¹⁾	U_d	kV	28	50	70
Rated lightning impulse withstand voltage ¹⁾	U_p	kV	75	125	170
Rated frequency ²⁾	f_r	Hz		50	
Rated normal current of busbars	I_r	A		...2500	
Rated normal current ³⁾	I_r	A		...2500	
Rated short-time withstand current	I_k	kA		...40	
Rated peak withstand current	I_p	kA		...100	
Rated duration of short-circuit	t_k	s		...3	
Insulating gas system ^{4) 5)}					
Rated filling level for insulation	p_{ae}	kPa ⁶⁾		120	
Rated filling level for insulation	p_{re}	kPa		130	
Degree of protection for parts under high voltage				IP65	
Degree of protection of the low voltage compartment				IP4X	

Table 10.2: Operating conditions

Ambient temperature, maximum ⁷⁾	°C	+40
Ambient temperature, maximum 24 h average ⁷⁾	°C	+35
Ambient temperature, minimum	°C	-5
Site altitude ⁸⁾	m	...1000
Average humidity measured over 24 h ⁹⁾	%	≤ 95
Average relative humidity in one month ⁹⁾	%	≤ 90
Ambient air	Ambient air not significantly contaminated by dust, smoke, corrosive or flammable gases or salts.	
Seismic withstand capability ¹⁰⁾	Tested according to IEEE Std. 693.	

Table 10.3: Panel weights

Panel type	Panel width [mm]	Weight, max. [kg]
Single busbar	2 x 400	1500
	600	1400
	800	2000
Double busbar	2 x 400	1800
	600	1600
	800	2400
Pressure relief duct at the rear (Increase in weight of the end panel)		250

¹⁾ Higher levels to international standards on request

²⁾ Rated current for 60 Hz on request

³⁾ Higher rated currents on request

⁴⁾ Insulating gas: SF₆ (sulphur hexafluoride)

⁵⁾ All pressures stated are absolute values relative to 20 °C

⁶⁾ 100 kPa = 1 bar

⁷⁾ Higher ambient temperature on request

⁸⁾ Greater site altitudes on request

⁹⁾ Take suitable action to prevent condensation in the low voltage compartment.

¹⁰⁾ Additional measures required (on request)

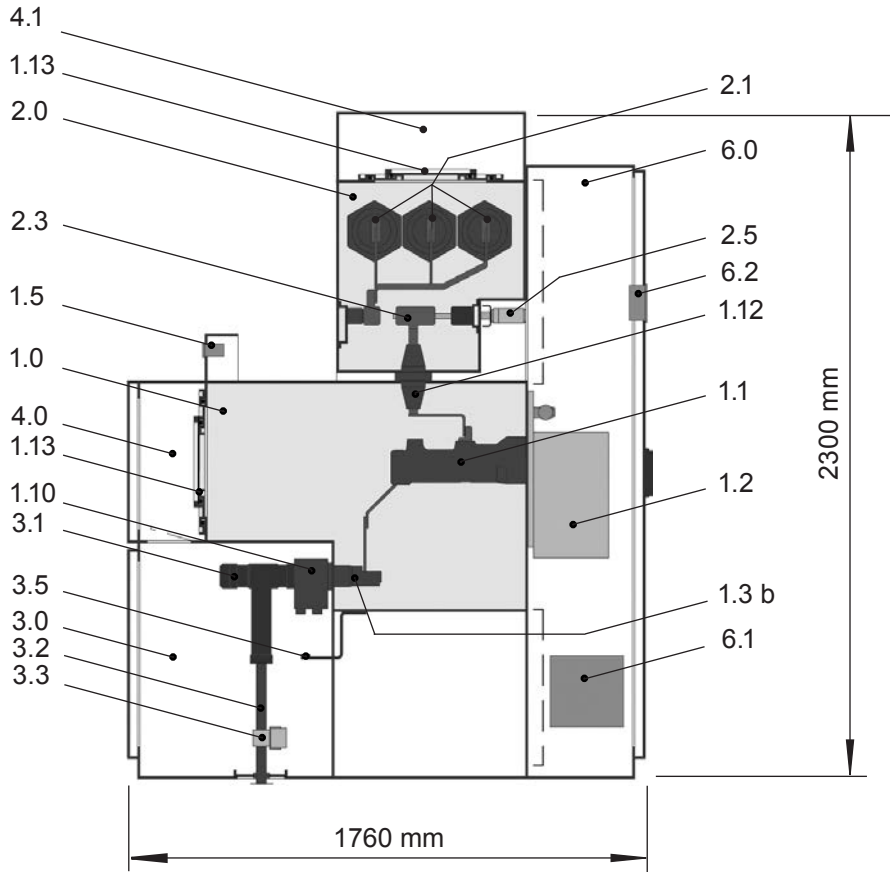

Double feeder panel, 630 A, (with outer cone), single busbar, example configuration

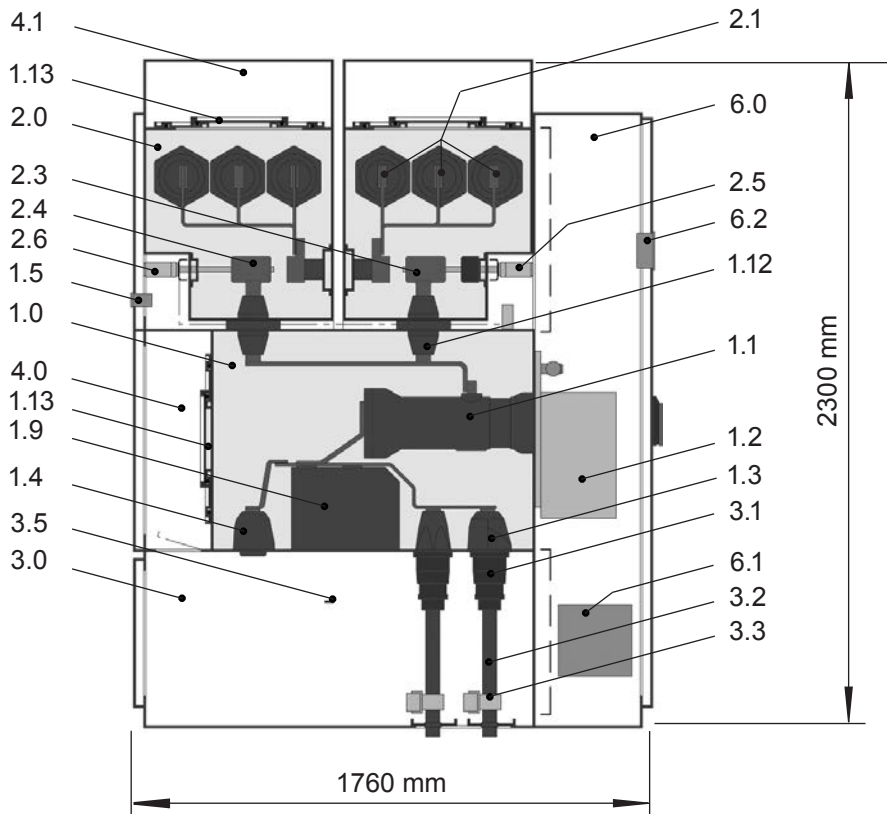

Outgoing feeder panel, 1250 A, double busbar, example configuration

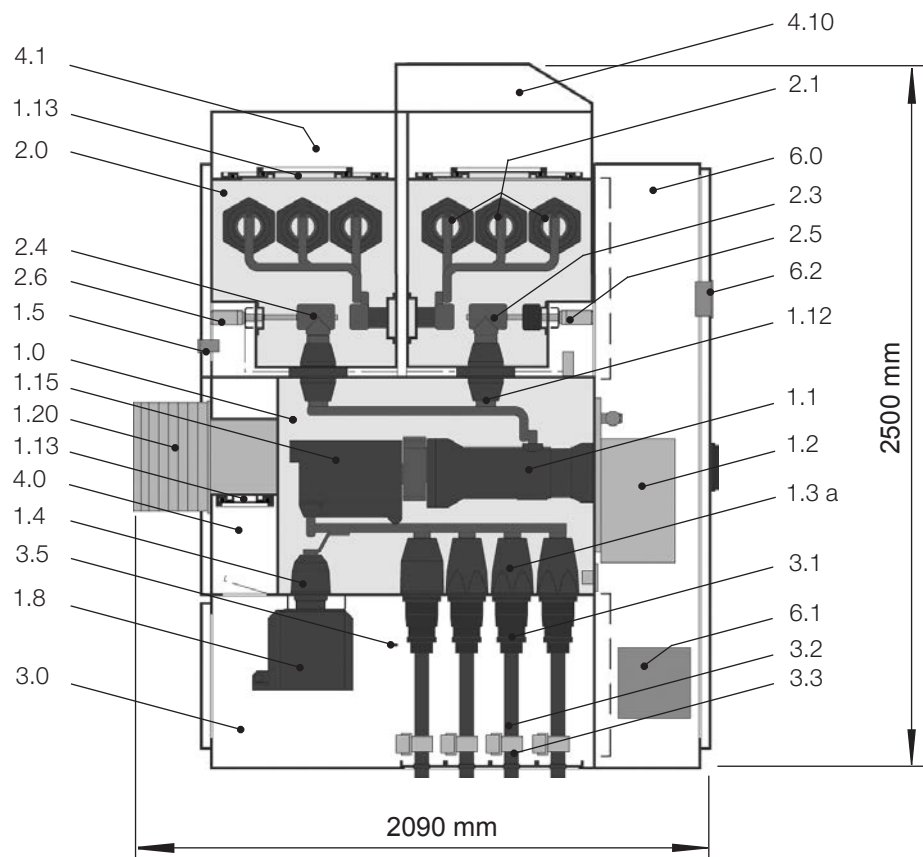

Feeder panel 2500 A, double busbar, example configuration

1.0	Circuit-breaker compartment	3.0	Cable termination compartment
1.1	Circuit-breaker pole	3.1	Cable connector
1.2	Circuit-breaker operating mechanism	3.2	High voltage cable
1.3	Cable socket	3.3	Cable fastener
1.3 b	Outer cone	3.5	Main earthing bar
1.4	Test socket (also for use with other plug-in devices)	4.0	Pressure relief duct, rear (for circuit-breaker compartment and cable termination compartment)
1.5	Capacitive voltage indicator system	4.1	Pressure relief duct, top (for busbar compartment)
1.8	Voltage transformer	4.10	Fan
1.9	Block-type transformer or sensor		
1.10	Ring core current transformer	6.0	Low voltage compartment
1.12	Bushing, circuit-breaker/busbar compartment	6.1	Central unit of a combined protection and control device
1.13	Pressure relief disk	6.2	Human-machine interface of a combined protection and control
1.15	Current transformer		
1.20	Heat sink		
2.0	Busbar compartment		
2.1	Busbar system		
2.3	Three position disconnector		
2.4	Disconnecter		
2.5	Three-position disconnector mechanism		
2.6	Disconnecter mechanism		

Contact



Your sales contact: www.abb.com/contacts

More product information: www.abb.com/productguide

Note: We reserve the right to make technical changes or modify the contents of this document without prior notice. With regard to purchase orders, the agreed particulars shall prevail. ABB AG does not accept any responsibility whatsoever for potential errors or possible lack of information in this document.

We reserve all rights in this document and in the subject matter and illustrations contained therein. Any reproduction, disclosure to third parties or utilization of its contents – in whole or in parts – is forbidden without prior written consent of ABB AG.

Copyright© 2008 ABB
All rights reserved

© Copyright ABB. 1VBA 680 602 P0102 (1.2.2014 - ABB)