

PRODUCT GUIDE

## FT Flexitest™ switch family

FT-1, FT-1F, FT-1X, FT-14, FT-14D,  
FT-19R, FT-19RX, FT-19RS, FT-22RS,  
test plugs and accessories



---

**With over 60 years of experience, ABB is the test switch manufacturer with the largest installed base in North America. ABB introduced the FT switch and continues to be the leader in innovation to make power system testing safer, faster and easier. Recent additions include the FT-14D Digital Flexitest™ switch, ergonomic separate source test plugs, FT cover shields, FT slotted covers for hanging tags, visible pole markers and reverse current shorting pole option.**

---

# Table of contents

<b>01. Features and application</b>	05
<b>02. The most complete family of test switches</b>	06
<b>03. Advantages</b>	11
<b>04. Specifications</b>	12
<b>05. Test plugs</b>	18
<b>06. FT Flexitest™ switches ordering information</b>	20
<b>07. Test plugs and accessories ordering information</b>	33
<b>08. FT switch covers</b>	36
<b>09. Warranty and diagrams</b>	41

---

# Safety symbols

## Symbols



This is the safety alert symbol. It is used to alert you to potential physical injury hazards. Obey all safety messages that follow this symbol to avoid possible injury or death.



**Danger** indicates a hazardous situation which, if not avoided, will result in death or serious injury.



**Warning** indicates a hazardous situation which, if not avoided, could result in death or serious injury.



**Caution** indicates a hazardous situation which, if not avoided, could result in minor or moderate injury.



**Notice** is used to address practices not related to physical injury.

# 1. FT Flexitest™ family

## Features and application

With more than 60 years of experience, ABB is the test switch manufacturer with the largest installed base in North America. The ABB Flexitest™ switch offers high quality and is the original FT.

### 1.1 Features

- Clear covers allow for easier visual check on switch status
- Colored switch handles simplify circuit identification
- Rear extended switches provide easier, faster access to wiring points
- 14 pole and 19-inch-wide rack-mounted test switches (FT-14 and FT-19R) help save space and installation time
- Patented 3D white lettering on the front and 3D white numbering on the rear of the test switch allows for easier identification of poles
- Comprehensive family of test plugs, including SafePlug™ — an individual current test plug with open current transformer (CT) protection
- Online configurator to easily create and order customized switches — <https://ftswitch.apps.us.abb.com/>
- FT-1 and FT-14 meet ingress protection IP41 for protection against dripping water from the front with shallow, clear and black covers installed
- FT-1 and FT-14 meet ingress protection IP2X for finger safety at the product rear

- FT-1 and FT-14 are RoHS compliant

### 1.2 Application

ABB Flexitest switch types FT-1 (10 pole, rear connected), FT-1F (10 pole, front connected), FT-1X (10 pole, extended terminals, rear connected), FT-14 (14 pole, rear connected) and associated test plugs provide a safe, simple, fast and reliable method to isolate, test and service installed equipment without disturbing the power system.

FT-14D is a new test switch solution for digital switchgear that uses low-energy voltage and current sensors. The FT-14D switch ties to cutting-edge digital strategies by allowing customers to integrate current and voltage sensors within digital switchgear and Relion® protective relays.

FT-19R, FT-19RX, FT-19RS and FT-22RS ABB Flexitest switch assemblies for rack and switchboard mounting permit convenient isolation of switchboard relays, meters and instruments, allowing for quick and easy multi-circuit testing by any conventional test method. These assemblies use FT-1 and/or FT-14 switches, depending on customer requirements.

A new slotted cover makes ABB Flexitest switches easy to identify by allowing the user to label each individual switch with a hanging tag to ensure correct operation of the power system.

## 2. The most complete family of test switches

**2.1. FT-1** standard 10 pole, rear connected test switch.

**2.2. FT-1F** surface-mount switch allows the user to make the same connections as with FT-1 but on the front of the switch.

**2.3. FT-1X** extended-length test switch brings the rear terminal connections to the same depth as most panel-mounted protective relays and equipment for easier and faster access to wiring points. Length extension of 8-inch or 10-inch depth is available.

**2.4. FT-14** provides the same features and reliability as FT-1 but with a maximum of 14 individual poles. Although supplying 40 percent more capacity than the FT-1, the FT-14 only requires 18 percent more space.

**2.5. FT-19R and FT-19RX** assemblies accommodate up to three FT-1 switches mounted on a 19-inch wide, two-rack unit (2RU), three-rack unit (3RU) or four-rack unit (4RU) high panel suitable for rack or switchboard mounting. These assemblies can be ordered with a full-length clear cover (standard) or optional full-length black, individual black or clear covers.

FT-19RX extends the rear terminals of the FT-1 switches to the same depth as most 19-inch rack-mounted equipment, thereby providing improved access to the rear terminals. FT-19RX two-rack unit (2RU) assemblies allow the user to mount protective relays or other equipment in the racks directly above and below the FT-19RX, optimizing the space in the rack and reducing the amount of wire required.

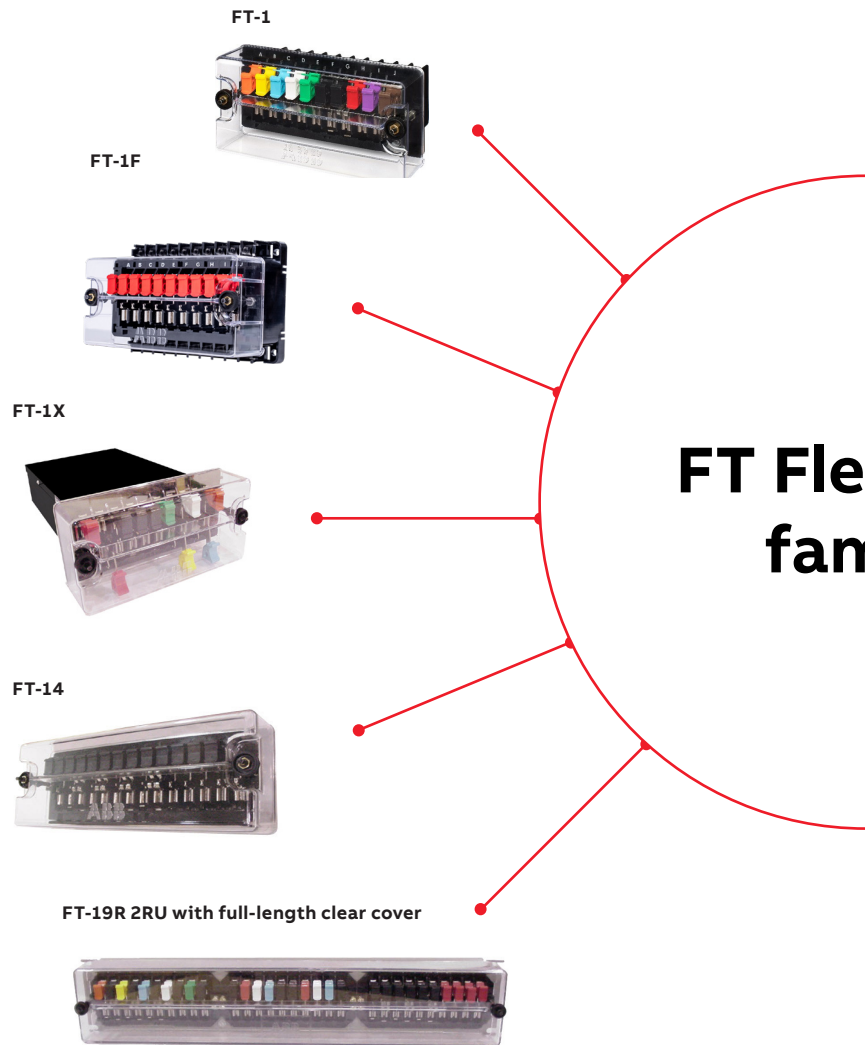

# xitest nily

**FT-19 3RU lockable version**



**FT-19R 3RU with special customer labels**



**FT-19RX 3RU with full-length clear cover**

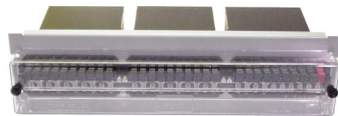

**FT-19RS**



**FT-22RS**



**2.6 FT-19RS** assemblies consist of up to two FT-1 switches, two FT-14 switches or the combination of one FT-1 and one FT-14 switch mounted on a 19-inch wide, two-rack unit (2RU), three-rack unit (3RU) or four-rack unit (4RU) high panel suitable for rack or switchboard mounting. Any combination of FT-1 or FT-14 switch styles may be selected with individual black or clear covers. Non-ABB equipment is not included with the assembly (see FT-19RS picture).

**2.7 FT-22RS** assemblies consists of up to three FT-1 or two FT-14 switches mounted on a 22-inch wide, two-rack unit (2RU), three-rack unit (3RU) or four-rack unit (4RU) high mounting panel suitable for rack or switchboard mounting. Any combination of FT-1 or FT-14 switch styles may be selected with individual black or clear covers.

Mounting panels for these assemblies can be of steel or aluminum. Steel panels are commonly available in ANSI 61 gray, ANSI 70 gray and RAL7035 gray, beige, light sandalwood, thunder blue, black and white, although panel color or finish, as well as panel height, can be customized to meet the user's requirements. The three-rack unit (3RU) assembly also allows switches to be positioned off-center, in either low or high upper mounting positions in the rack panel, allowing room for special label requirements.



## FT-14D digital test switch

Revolutionary technology to make testing safer, faster and easier

01 Front view FT-14D based on the FT-14 interface

02 Rear view FT-14D adds electronic module on the back with RJ45 connectors

03 FT-14D test harness and FT-14D separate source test plug

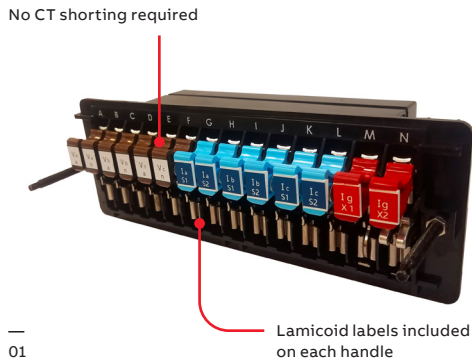

01

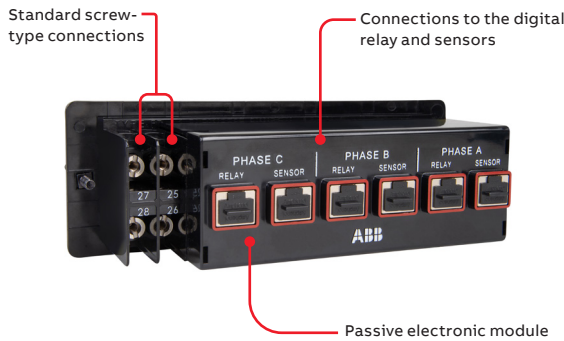

02

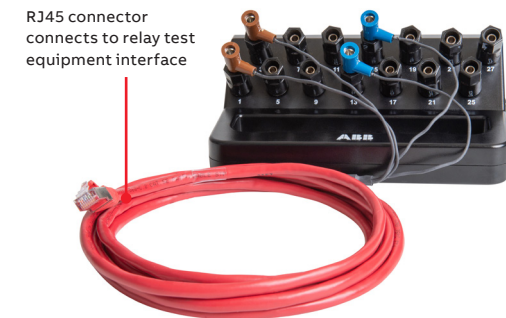

03

**2.8 FT-14D** is used for testing, commissioning and metering of relays and current and voltage sensors used in digital switchgear. The redesigned FT-14D has a red border for visual identification. It accepts pin configuration according to the IEC 61869 standard and is backward compatible with IEC 60044 sensors.

FT-14D incorporates a passive electronic module on the rear with RJ45 connection to the relays with low-energy voltage and current sensor inputs. The FT-14D maintains the same front interface as the standard FT-14 Flexitest switch. It meets ANSI/IEEE standard C37.90, UL and is ESD proven. See page 23 for style number information.

### Testing

For testing purposes, use the FT-14D in conjunction with two accessories — the FT-14 separate source test plug and the FT-14D test harness (figure 03). Follow these steps:

- Connect the FT-14D test harness RJ45 connectors to an interface adapter that is plugged into the protection relay test equipment.
- Insert the banana plugs into the FT-14 separate source test plug.
- Insert the FT-14 separate source test plug into the FT-14D by placing the switch blades in the open position.

### CAUTION

All relays and test equipment must be properly grounded.

### WARNING

Connections to all equipment should be made using standard and safe connection practices. Due to the low-energy sensing during system operation, it is important not to touch the open or closed FT-14D switch jaw terminals since relay misoperation can occur. Therefore, during testing and maintenance, it is also recommended to first disconnect the relay trip circuit as a precaution.

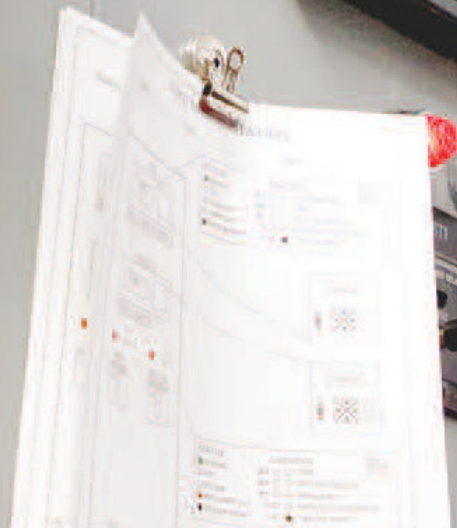

## 3. Advantages

ABB Flexitest switches provide a safer, more reliable and more cost-effective means to wire the output, input and power relays, meters and other associated equipment to external devices for in-service testing.

### 3.1 Safe and convenient

All measurements and tests can be performed at the front of the switchboard, without taking any devices out of service, and without the need to access wiring at the rear of the devices.

ABB Flexitest switches and test plugs have all the features necessary for applications involving the safe measurement and isolation of individual currents, voltages and digital I/O signals to facilitate testing of substation instrumentation and protection devices.

The make-before-break current shorting feature enables test personnel to quickly and safely isolate equipment from current transformer (CT) circuits.

Voltage measurements can also be made directly on ABB Flexitest switches, without disturbing existing connections. The test clip located on the top of each pole allows for connection with standard spring-clip test leads.

### 3.2 Fast and reliable

When test plugs are used, any number of circuits may be tested in rapid succession. One plug properly connected can test all instruments or meters of a particular type.

### 3.3 Maximum flexibility

Test switches can be assembled in a variety of different arrangements and colors to match customer requirements. To build new or view existing ABB Flexitest switches and FT-19R panels, please visit our interactive FT-1 Configurator website at <https://ftswitch.apps.us.abb.com/> (see page 20).

### 3.4 Security

With the cover in place, a meter seal can be placed through either of the cover studs of any ABB Flexitest switch to prevent unauthorized access to the switch. As an additional feature, a clear cover is available that can also be installed with the switch blades in the fully open or closed positions. In addition, a barrier has been incorporated into the cover to prevent knife switches from being left partially open. Optional padlocking provisions are available for most covers, allowing access to authorized personnel only.

### 3.5 Quality

With over 60 years of field-proven applications, ABB is the test switch manufacturer with the largest installed base in North America. ABB Flexitest test switches have been an industry standard for many years.

### 3.6 Technical and application engineering support

Available 24/7 at +1 800 929 7947 Ext 1.

## 4. Specifications

### 4.1 Certifications

All ABB Flexitest switches meet or exceed all requirements of ANSI/IEEE standard C37.90. Class 1E switches meet IEEE C37.98, C37.105, 323-1983 and 344-1987 standards.

UL and CUL file number E504331, and Class 1E certification are available for most test switches. Contact your ABB representative for more details.

FT-1 and FT-14 meet ingress protection IP41 for the front of the product with shallow clear and black covers installed. FT-1 and FT-14 meet ingress protection IP2X for the rear.

FT-1 and FT-14 are RoHS compliant.

FT-1 Environmental Product Declaration published in 2025.

### 4.2 Ratings

All ABB Flexitest switches are rated at 600 V AC or DC, 30 A continuous, 500 A for 1 sec.

### 4.3 Mounting

The FT-1, FT-14 and FT-1X switches are designed for semi-flush mounting on the front of switchboard panels, facilitating inspection and accessibility. The FT-1F is designed for surface mounting and can also be mounted on a unistrut with the use of a unistrut adapter plate. Refer to figures 37 to 40 on pages 42–45 for the specific outline and drilling plan information for each switch.

The FT-19R, FT-19RX and FT-19RS are designed for mounting on 19-inch wide rack structures or conventional panels. The FT-22RS are designed for mounting on 22-inch rack structures. Outline, drilling plan and switch dimensions are shown on pages 42–52.

**Table 1: Approximate shipping weight and dimensions**

Device	Net lbs (kg)	Shipping lbs (kg)	Shipping container L x W x H in (mm)
FT-1 and FT-1F	1.75 (0.79)	3 (1.4)	4 (100) x 7 (177) x 5 (126)
FT-1X	2.7 (1.25)	3.75 (1.7)	4 (100) x 12 (300) x 7 (177)
FT-14	2.5 (1.5)	3.25 (1.5)	4 (100) x 9 (225) x 5 (126)
FT-14D	2.4 (1.09)	2.7 (1.23)	4 (100) x 9 (225) x 6 (153)
FT-19R	7.0 (3.18)	12 (6)	10 (254) x 21 (534) x 10 (254)
FT-19RX	9.0 (4.08)	17 (8)	10 (254) x 21 (534) x 16 (407)
FT-19RS	7.0 (3.18)	12 (6)	10 (254) x 21 (534) x 10 (254)
FT-22RS	7.0 (3.18)	12 (6)	10 (254) x 24 (610) x 10 (254)
Separate source test plug (10 position)	1.5 (0.68)	3 (1.4)	10 (253) x 7 (177) x 5 (126)
In-service series test plug (10 position)	1.5 (0.68)	3 (1.4)	10 (253) x 7 (177) x 5 (126) For up to 4 pieces
Individual current circuit test plug	0.1 (0.045)	1 (0.45)	10 (253) x 7 (177) x 5 (126) For up to 30 pieces

—  
04 FT switch terminal numbering, rear view.  
—  
05 FT switch terminal lettering, front view



—  
04

—  
05

**4.4 Construction**

The base of all ABB Flexitest switches is made of a high-grade molded thermoplastic that provides a tough, insulated enclosure. Barriers are molded into the base (front and rear) to separate the switch units from one another. The barriers provide insulation between poles, and also ample wiring space between terminals. The terminals of the FT-1X are extended either 8 or 10 inches beyond the switch blades located on the front of the switch. The front of the switch is marked with a white raised 3D lettering, which allows easier identification of poles. The back of the terminals is marked with a white raised 3D numbering, which allows easier identification of poles and helps prevent inadvertent upside down installation.

All switches may be purchased with a black opaque cover or a deep clear cover. The deep clear cover offers the user the unique option of intentionally leaving switch handles in the open position with the cover in place, maintaining the provision for a meter seal. This enables the user to service electrical equipment while still complying with OSHA tag and lockout procedures.

Lockable covers (in black or clear) are also available upon request.

Any cover can be ordered separately to retrofit any existing switch, maintaining the same ease of use and accessibility. See ordering information on page 36.

**4.5 Cover**

All ABB Flexitest switch covers provide a tough insulated enclosure for the switch and are made from a durable thermoplastic material. Covers are fastened to the switches with thumbnuts on each end that can be loosened and tightened by hand, or with a ¼-inch nut driver. This is the same size nut driver used on the hex head terminal screws of all ABB Flexitest switches. All covers have the provision to accept meter seals.

—  
FT test switch cover selection samples:  
06 Shadow black  
07 Deep clear  
08 Lockable

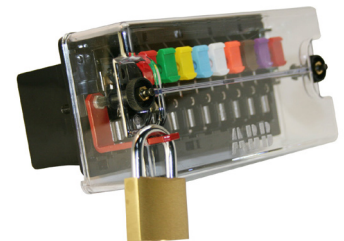

—  
06

—  
07

—  
08

**4.6 Poles**

FT-1, FT-1F and FT-1X switches are available in combinations of one to a maximum of 10 individual poles or switch units. FT-14 switches are available in combinations of one to a maximum of 14 poles or switch units. Each pole is identified by a letter (A to J or A to N) visible along the top of the base from left to right (front view).

Individual pole designations are used to identify each pole according to its type or function. In order to develop a complete switch arrangement, pole designations should be listed sequentially from left to right to account for every pole position on the switch. Unused poles are identified by the letter X.

Each individual pole is of a knife-blade type. There are two different types of poles, potential and current.

For quick, easy, user-friendly configuration of ABB Flexitest switches, please visit <https://ftswitch.apps.us.abb.com/>.

**4.6.1 Potential poles**

Potential poles (P) are configured as single, non-shorting knife blades for use in potential, trip or control circuits. P designates a potential, trip or control circuit with a black handle. Potential poles with other color handles are available by replacing the “P” with the appropriate designation as per the chart on page 15.

Each potential pole can also be described with two characters (P1 to P9). P indicates potential and the second character is a numeric color code for the switch handle.

**4.6.2 Current poles**

Current poles are typically configured in sets of two (C-C), for use with current circuits, and consist of a current test jack, a shorting spring, a shorting blade, and a non-shorting blade (see Figure 2). The positions of the short circuit springs are always visible from the front of the switch.

C designates a single current circuit, non-shorting pole, with a current test jack and a black handle. Current poles with other color handles are available by replacing the “C” with the appropriate designation per chart on page 15.

Each current pole can also be described with two characters (C1 to C9). C indicates current and the second character is a numeric color code for the switch handle.

Current poles typically span more than one pole position. Pole designations C-C, C-C-C, C-C-C-C and C-C-C-C-C indicate current shorting poles (make-before-break) with black handles. Note that any color handle may be selected for any pole position by using the appropriate pole designation, ex: 5-R or C-9-7 (alternately C5-C2 or C1-C9-C7).

Blade assembly of two-position current poles

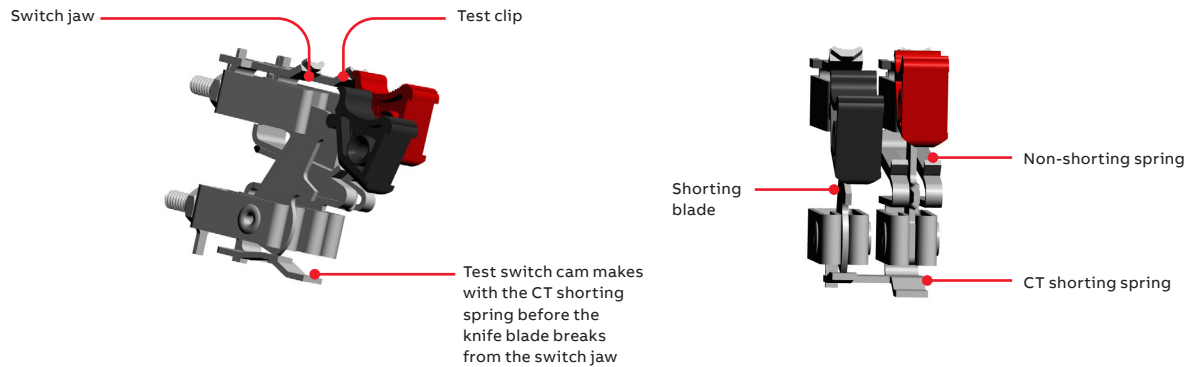



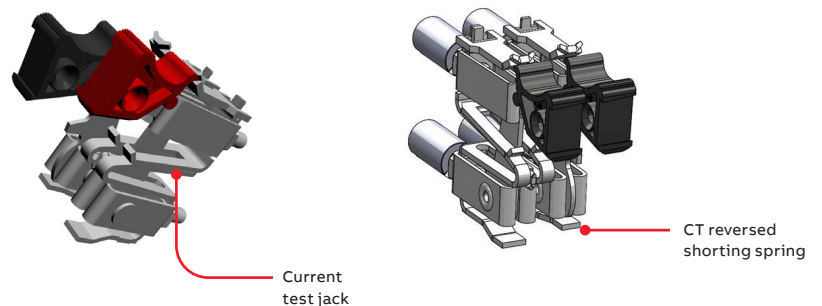







Visual FT switch disconnect “make-before-break” operation

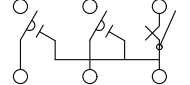

Visit <https://ftswitch.apps.us.abb.com/> to build any complete FT switch arrangement, select

options, view schematic details and get style number information.

**Table 2**

Pole type	Potential pole designation	Handle color	Description and schematic symbols	Schematic legend	
Potential	P	P1	Black	Potential, non-shorting blade 	Non-shorting blade 
	T	P2	Red		
	H	P3	Brown		
	V	P4	Purple		
	G	P5	Green		
	Y	P6	Yellow		
	Z	P7	Blue		
	W	P8	White		
	O	P9	Orange		
	L	L1	Black **		
Current	C	C1	Black	Current, non-shorting, with test jack and blade 	Current test jack 
	R	C2	Red		
	3	C3	Brown		
	4	C4	Purple		
	5	C5	Green		
	6	C6	Yellow		
	7	C7	Blue		
	8	C8	White		
	9	C9	Orange		
	D	D0	N/A		
Current shorting†	C-C	C1-C1	Black **	Current shorting (make-before-break), with test jack and blade 	C-C-C 
	C+C	C1+C1		Reversed current shorting (make-before-break), with test jack and blade in reverse configuration 	
	C-A	C1-A1		Current shorting (make-before-break), with standard blade, no current test jack 	
	C-B	C1-B1		Current shorting (make-before-break), with stud only, no current jack, no switch blade 	
	C-D	C1-D1		Current shorting (make-before-break), with current test jack, no switch blade 	
	C-E	C1-E1		Current shorting (make-before-break), with shorting blade, no current test jack 	
	C-S	C1-S1		Current shorting (make-before-break), with fixed shorting strap 	
	Miscellaneous	S	S0	None	
J		J0	None	Current jaw, no blade	
N		N0	None	Terminal stud in blade location, no jaw	
U		U0	None	Stud and test clip in jaw location, no blade	
X		X0	None	Empty pole position	

† = Current shorting poles are also available spanning up to 5 positions (ex: C-C-C-C-C or alternately C1-C1-C1-C1-C1)

\*\* = Every color handle is available by substituting appropriate pole color designation in desired location

- 09 Switch handles with interlocking bar
- 10 FT switch terminals, rear view (FT-1 shown)
- 11 FT switch terminals, rear view (FT-1 shown)



— 09

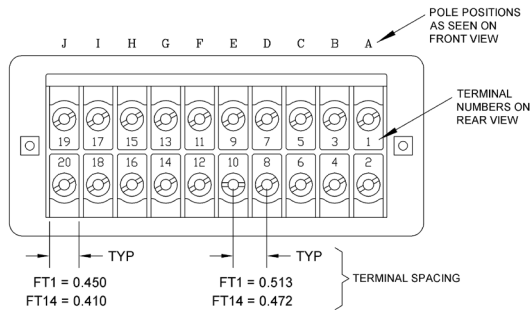

— 10

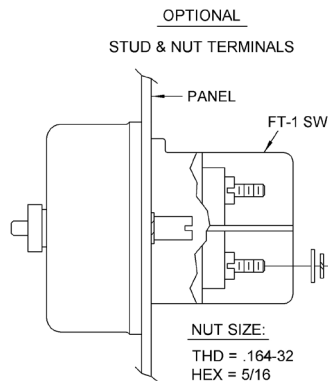
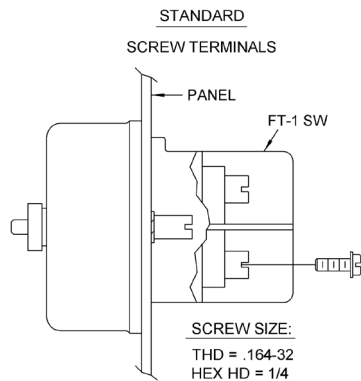

— 11

The reversed current shorting pole option positions the current transformer (CT) shorting spring, individual current jack and associated knife blades in reverse. The pole designations for this configuration are available only in sets of 2 and are described with 2 characters (C+C). The “+” sign is the indication for the reversal. Current shorting is performed with the right-hand blade versus the traditional left-hand blade. Current monitoring is accessed with an individual current test jack in the left-hand position.

**4.7 Switch handles**

Switch handles are made of molded thermoplastic material. They are typically black for potential and current circuits and red for trip circuits. In addition to black and red, switch handles are available in various other colors (brown, purple, green, yellow, blue, white and orange) for simple circuit identification. Each handle has a dovetail indentation that can hold a circuit identification label. To create and print custom labels, please use the template found on our website under **Test switch and accessories**. In the ‘Downloads for Test Equipment’ section, select ‘List.’

Knife blade switches can be operated independently, or ganged together with a horizontal interlocking tie bar to suit testing needs. A hole runs through the middle of each switch handle to allow insertion of interlocking bars that can mechanically tie 2, 3, 4, 5, 6, 8, 10 or 14 adjacent switch handles together. Interlocking bars can be screwed into either side of the handle and can be easily removed if necessary. Interlocking bars are ordered as a separate line item and installed by the customer; see “Test plug and accessories — ordering information” on page 33.

**4.8 Terminal connections**

Connection terminals are located at the rear of the switch (except on the front connected FT-1F). Most ABB Flexitest switch terminals are marked with a white raised 3D numbering, which allows easier identification of poles along the rear of the switch (1 to 20 on FT-1 and 1 to 28 on FT-14), as shown in figure 04. Each pair of numbered terminals is associated with a matching pole designated by a letter on the front of the switch.

All required terminal hardware is supplied with every ABB Flexitest switch (see figure 10). Screw terminals are provided standard with all ABB Flexitest switches. Connections are made with a hex washer head screw, #8 thread size (0.164–32), ¼-inch hex head.

Stud and nut terminals are an optional feature.

—  
12 FT switch arrangement,  
front view (FT-1 shown)

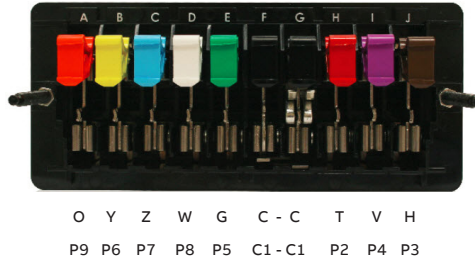

—  
12

Connections are made with two washers and a nut. A special  $\frac{5}{16}$ -inch nut driver can be purchased from ABB to connect to stud terminals; see “Test plug and accessories — ordering information” on page 33.

**⚠ WARNING**

Connections to ALL equipment should be made using standard and safe connection practices. Recommended maximum torque values for all FT switch terminals is 16 in-lbs. Exceeding this torque may result in damage to terminal threads. On extended versions of the FT switch (ex. FT-1X), exceeding maximum torque values may lead to loosening of internal hardware. Even number terminals (bottom row) of ABB Flexitest switches should be connected to voltage transformers and current transformers, while odd number terminals (top row) should be connected to equipment that is to be isolated, such as meters and relays. Maximum lug size = yellow 10–12 AWG ring terminal. Recommended lug size for PTs is 12 AWG and for CTs is 10 AWG.

**4.9 Switch arrangement**

Pole positions are identified from left to right on the front view of the switch by the letters “A” through “J” or “A” through “N”. Individual pole designations are used to identify each pole according to its type or function. To develop a complete switch arrangement, pole designations should be listed sequentially from left to right to account for every pole position on the switch. Unused poles are identified by the letter X.

**⚠ WARNING**

All switch arrangements should be checked for adequate current transformer shorting when applied to current transformer circuits.

## 5. Test plugs

—  
13 Safe plug with open CT protection

—  
14 In-service series test plug

—  
15 Individual current circuit test plug

—  
16 Separate source test plug



—  
13

### 5. Test plugs

Test plugs used in conjunction with ABB Flexitest switches enable easy measurement, calibration, verification and maintenance of relays, meters and instruments.

#### 5.1 In-service series test plug

The “in-service” series test plug with a maximum of 10 positions is designed to match the pole configurations of specific styles of FT Flexitest devices (either FT-1, FT-1F, FT-1X switches or FT case relays).

This test plug is typically used to connect devices measuring the currents and voltages being applied to the switchboard relays, meters and instruments without interrupting or short-circuiting the circuit. Only current test switches with a current test jack must be opened before inserting the series test plug. Connections to the test plug must be made before inserting the test plug into a ABB Flexitest switch or relay.

Not every switch or relay pole configuration is suitable to accept an in-service series test plug. For available styles, see table 1, FT-1 switch selection guide 1VAC397062-SG. You may also refer to your ABB representative or the ABB FT-1 configurator at <https://ftswitch.apps.us.abb.com/>.



—  
14



—  
15



—  
16

### WARNING

When using an in-service series test plug for current measurements, connections from the test plug to the measuring instruments must be made before inserting the test plug in place.

#### 5.2 Individual current circuit test plug

This plug consists of two conducting strips separated by an insulating strip. The ammeter is connected to these strips by terminal screws and leads carried out through holes in the back of the insulated handle. (See figures 15 and 17.)

The standard test plug inserts into the current test jack with the red part of the handle facing up, allowing the alignment nipple and tab to guide the connector into the test jack.

#### 5.3 SafePlug with open CT protection

The SafePlug is an individual current circuit test plug with open current transformer (CT) protection that provides a safe, simple, fast and reliable method to test and service installed equipment while reducing risks due to operator error, incorrect equipment settings or deviation from correct test procedures. Its design helps prevent the shock hazards, outages and erroneous meter readings all associated with open CTs.

If a CT opens during operation, the test plug shorts the CT to protect the operator, typically within 100 microseconds or less (6/1000th of a cycle). At the same time, a red LED provides visual indication of the fault.

- 17 Individual current circuit test plug inserted in ABB Flexitest relay case
- 18 Separate source test plug
- 19 FT test kit

**⚠ WARNING**

When using an in-service series test plug for current measurements, connections from the test plug to the measuring instruments must be made before inserting the test plug in place.

**5.4 Separate source test plug**

Both the 10-position FT-1 and 14-position FT-14 separate source test plugs isolate the external connections from the relay or equipment under test. The test plugs accept all common-size banana plugs, ring wire connectors and spade lugs, and have a through hole for meter probe or wire connections. The separate source test plugs provide quick circuit testing by fitting into the stationary contact jaws of any matching ABB Flexitest type FT case or switch.

**5.4.1 Ergonomic separate source test plug**

The 10- and 14-position ergonomic separate source test plugs use an alignment boss at each end to connect with the FT-1 and FT-14 switch cover mounting posts, respectively, for secure and accurate alignment. The ergonomic separate source test plug incorporates a handle for ease of insertion into the FT test switch. The separate source test plug 45-degree connector angle makes it easy to access and connect test leads at virtually any height. The separate source test plug incorporates a unique extended isolating barrier that prevents relay and power system misoperation by performing a secure break-before-make operation when inserted or disconnected. The separate source test plug design connects the relay inputs and outputs to a set of binding banana posts on the top of the test plug. An insulated barrier along the bottom of the blades isolates the relay circuits from external connections. Test circuits can then be connected to these binding posts, which are staggered for easy accessibility. Before inserting the separate source test plug into service, all switch blades must be placed in the full open position. In an ABB Flexitest type FT case, the 10-position separate source test plug is inserted in the bottom switch jaw with the binding posts up and in the top test switch jaw with the binding posts down.

**5.4.2 Standard separate source test plug**

The 10-position standard separate source test plug features L-shaped test blades to ensure quick, accurate alignment between the test plug and the stationary contact jaws. The standard separate source test plug is recommended for testing electromechanical relays in the ABB Flexitest type FT case.

**⚠ WARNING**

10-position FT-1 standard separate source test plug: To prevent relay misoperation, do not insert or remove the 10-position separate source test plug while the test set leads are attached. Provision is made only on current poles with shorting springs to automatically short-circuit current transformer circuits when the knife switches are opened prior to inserting the test plug.

**5.5 ABB Flexitest test kit**

The ABB Flexitest test kit comes with a convenient carrying case to hold your handheld meter, test plugs, patch cords, test clips and test probes in neat order. ABB Flexitest test kits can be ordered with your selected quantities of test plugs, safety patch cords, test clips and test probes. Patch cords are highly durable and flexible. Contact your local ABB representative for a quotation. For more information, see “Test plugs and accessories — ordering information” on page 33.

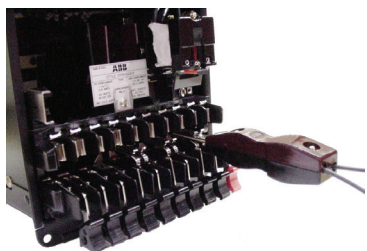

17



18



19

# 6. FT Flexitest switches ordering information

## FT-1 configurator

ABB offers a web-based tool to help build any complete FT switch arrangement, select options, view schematic details and get style number information. We strongly recommend the use of the web-based tool for quick, easy and user-friendly configuration of ABB Flexitest switches.

The following products can be easily configured:

- FT-1 (10 pole)
- Front connected FT-1F
- Extended terminals FT-1X
- Replacement switches for FT-19R
- FT-14 (14 pole)
- FT-19R switch panel assemblies
- FT-19RX switch panel assemblies

Please visit ABB's FT-1 configurator website at <https://ftswitch.apps.us.abb.com/>

Screenshots from <https://ftswitch.apps.us.abb.com/> When style numbers are not available, "TBD" (to be determined), order by "Arrangement".

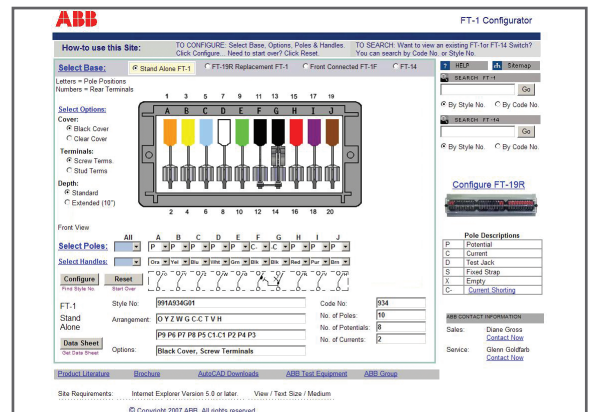
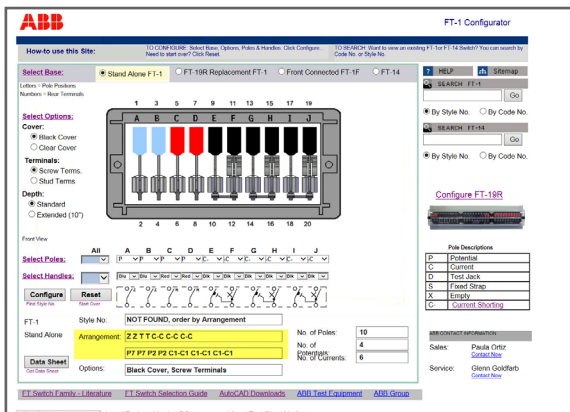
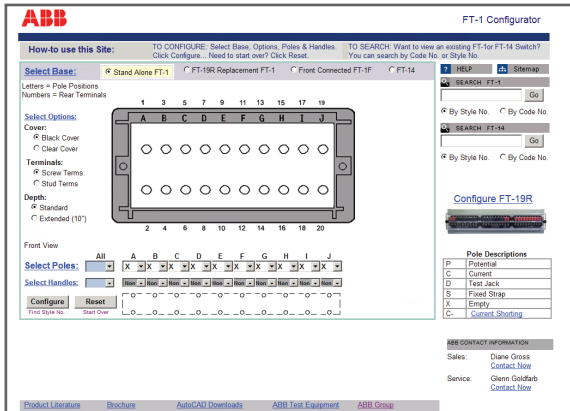

## FT-1 and FT-1X

### 10 pole Flexitest switches

#### FT-1 10 pole switch

Style numbers are assigned by the factory.

Choose from available options by adding style prefix as shown.

Individual covers for FT-1 to be used on FT-19R application should be ordered as a separate item. See ordering information table on page 34.

Example style number:



—  
Style prefix

Description	Code
Black cover, screw terminals	None
Black cover, stud and nut terminals	S
Black cover shield, screw terminals	K
Black cover shield, stud and nut terminals	K S
Clear deep cover, screw terminals	C
Clear deep cover, stud and nut terminals	C S
Clear shallow cover, screw terminals	M
Clear shallow cover, stud and nut terminals	M S
Clear cover shield, screw terminals	G
Clear cover shield, stud and nut terminals	G S
Black slotted cover with barrier, screw terminals	T

Description	Code
Black slotted cover with barrier, stud and nut terminals	T S
Lockable black cover, screw terminals	L
Lockable black cover, stud and nut	L S
Lockable clear deep cover, screw terminals	L C
Lockable clear deep cover, stud and nut	L C S
Lockable clear shallow cover, screw terminals	L M
Lockable clear shallow cover, stud and nut	L M S
FT-19R application, screw terminals	R
FT-19R application, stud and nut terminals	R S

#### FT-1X 10 pole switch with extended terminals, rear connected

Style numbers same as FT-1.

Choose from available options by adding style prefix as shown.

Individual covers for FT-1 to be used on FT-19R application should be ordered as a separate item. See ordering information table on page 28.

Example style number:



—  
Style prefix  
Same as FT-1

—  
Extended length

Description	Code
10.25 inches	X 1 0
8.25 inches	X 0 8

## FT-1F and FT-14

10 and 14 pole Flexitest switches

### FT-1F — 10 pole front connected

Style numbers are assigned by the factory.

Choose from available options by adding style prefix as shown.

Example style number:



Description	Code
Black cover, screw terminals	F
Black cover, stud and nut terminals	FS
Black cover shield, screw terminals	KF
Black cover shield, stud and nut terminals	KSF
Clear deep cover, screw terminals	CF
Clear deep cover, stud and nut terminals	CSF
Clear shallow cover, screw terminals	MF
Clear shallow cover, stud and nut terminals	MSF
Clear cover shield, screw terminals	GF

Description	Code
Clear cover shield, stud and nut terminals	G S F
Black slotted cover, screw terminals	T
Black slotted cover, stud and nut terminals	T S
Lockable black cover, screw terminals	L F
Lockable black cover, stud and nut	L S F
Lockable clear deep cover, screw terminals	L C F
Lockable clear deep cover, stud and nut	L C S F
Lockable clear deep cover, screw terminals	L M F
Lockable clear deep cover, stud and nut	L M S F

### FT-14 — 14 pole switch

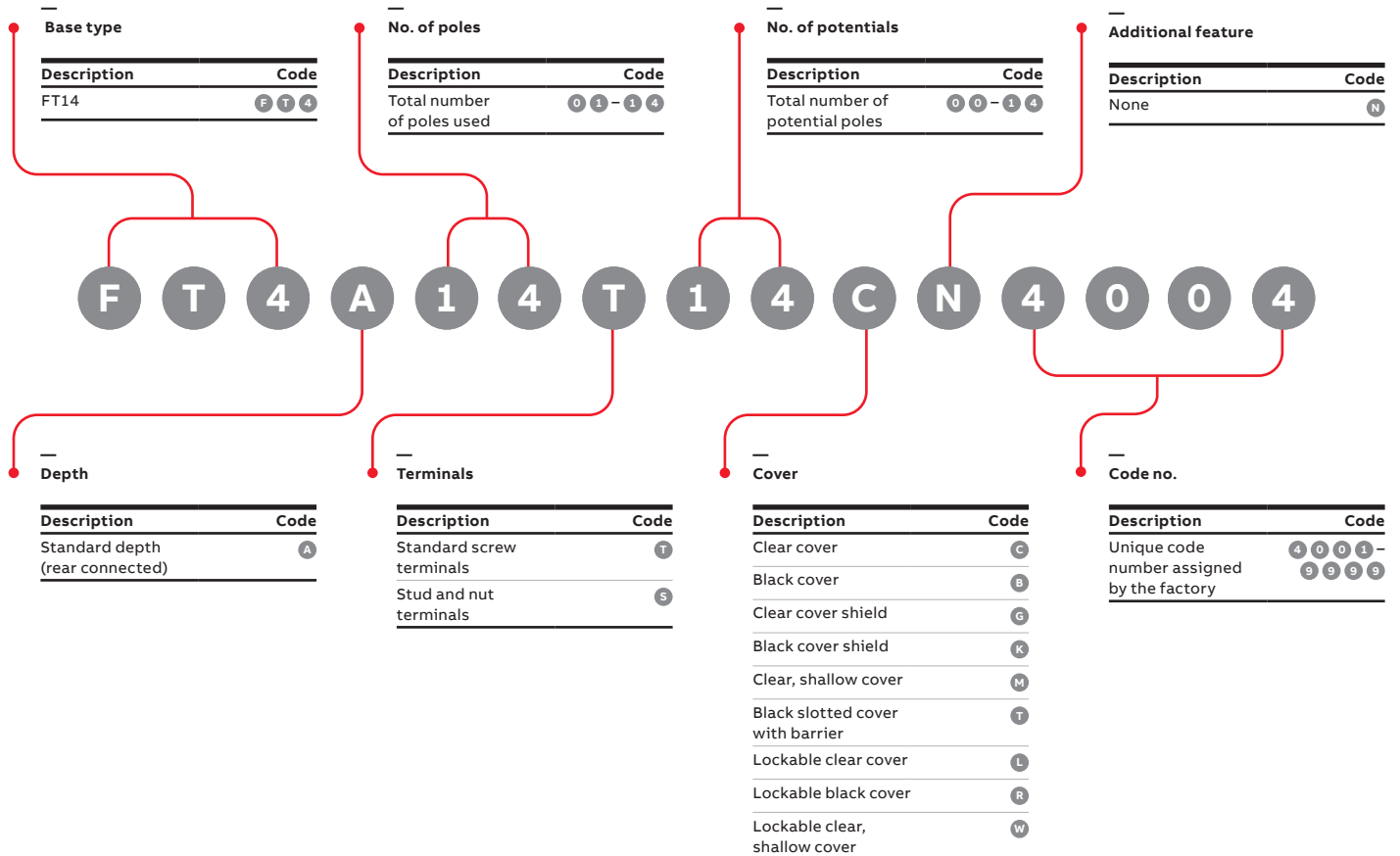

# FT-14D

## 14 pole digital Flexitest switch

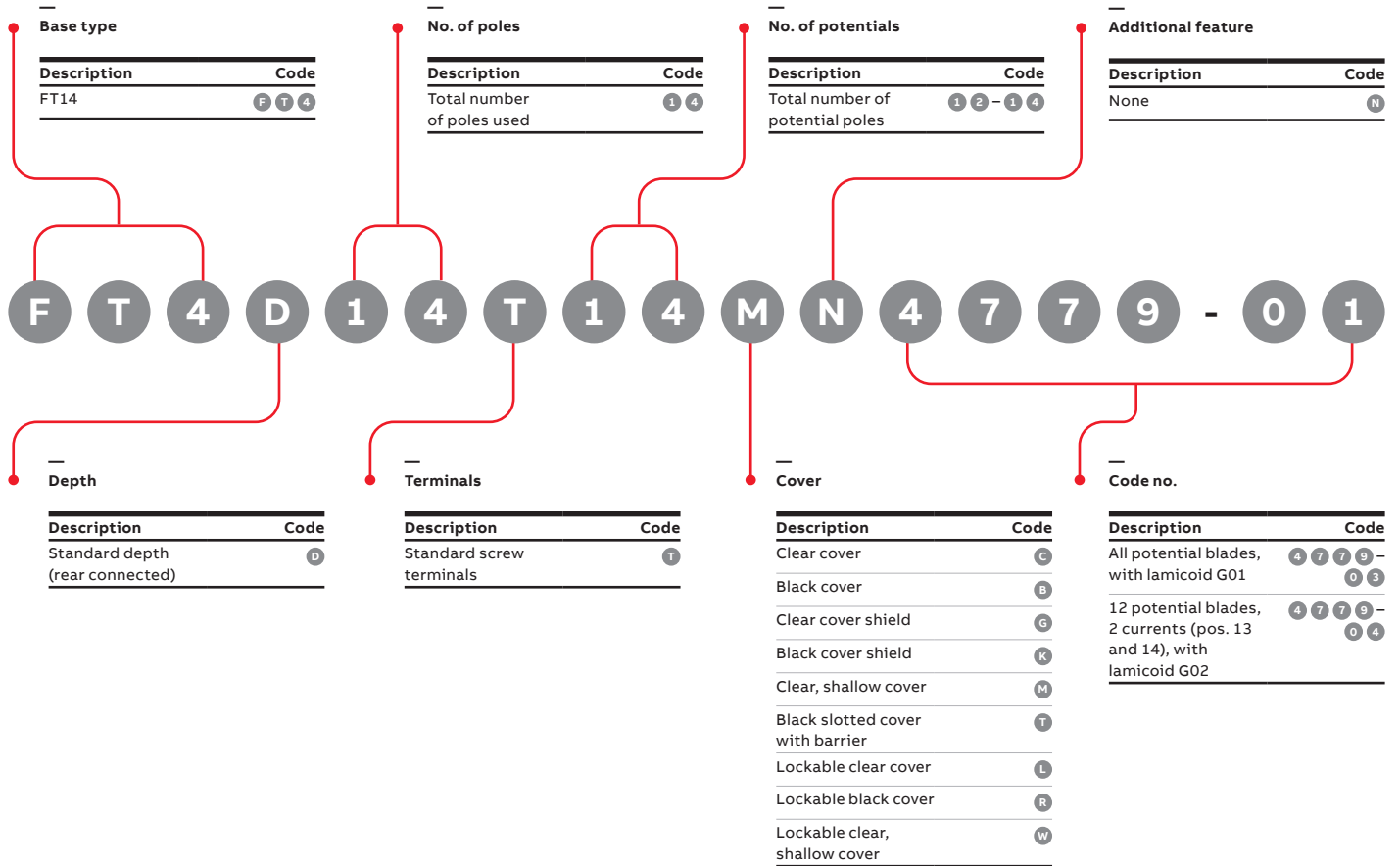

**Table 3**

FT-14D and cover options	Standard style numbers
Clear shallow cover with potential terminals 13, 14	FT4D14T14MN4779-03
Black cover with potential terminals 13, 14	FT4D14T14BN4779-03
Clear shallow cover with current terminals 13, 14	FT4D14T12MN4780-04
Black cover with current terminals 13, 14	FT4D14T12BN4780-04

**Table 4**

FT-14D test harness	Style number.
Quantity 3 (kit for 3-phase testing)	95A1159G02
Quantity 1	95A1159H02

Note: FT-14D can be ordered as part of a kit including merging adapters to use with ABB or SEL relays. Refer to FT switch online configurator (<https://ftswitch.apps.us.abb.com/>) for the kit style numbers.

**6.1 FT-1, FT-1F and FT-1X** switches are available in any combination of one to 10 poles. Each different configuration of poles is assigned a unique part number or style number by the factory. See ordering information chart for FT-1, FT-1X and FT-1F on pages 21–22.

The standard FT-1 style number defines a unique pole configuration with black cover and screw terminals; ex: 129A501G01. Adding a prefix and/or suffix to the standard style number allows the selection of options for FT-1 as well as the ability to create complete FT-1F and FT-1X style numbers.

Customers may also place an order by providing a complete switch arrangement definition as well as the selected options; ex: P X P C-C C-C C-C P (P1 X0 P1 C1-C1 C1-C1 C1-C1 P1), clear cover, screw terminals. For configurations -A or -E, the double character should be used.

#### **6.1.1 Terminal connections**

An optional FT-1 switch with stud and nut termination can be supplied at no additional charge. Style number prefix “S” is used for this option; ex: S129A501G01. For optional clear cover with stud and nut terminals use style number prefix “CS”; ex: CS129A501G01. See pages 21–22 for more ordering details.

#### **6.1.2 Cover**

An optional clear cover will be supplied instead of the black cover by using style number prefix “C”; ex: C129A501G01.

#### **6.1.3 Depth**

An FT-1X extended switch with black cover will be supplied by using suffix “X08” for 8 inches and “X10” for 10 inches; ex: 129A501G014X08 or 129A501G01X10.

An FT-1X extended switch with clear cover will be supplied by using prefix “C” and suffix “X10”; ex: C129A501G014X10

#### **6.1.4 Front connected**

Adding a prefix “F” to the standard style number is used for a front connected FT-1F switch, which allows the user to make the connections on the front of the switch.

**6.2 FT-14** switch is available in any combination up to 14 poles. Each different style number is based on a smart part number system. See ordering information chart on page 22.

#### **6.2.1 Terminal connections**

A standard FT-14 switch with screw termination will be supplied when using the normal style number. An optional FT-14 switch with stud and nut termination can be supplied at no additional charge provided when the seventh character on the smart part number is changed from “T” to “S.”

#### **6.2.2 Cover**

A standard FT-14 switch with clear cover will be supplied when using the normal style number. An optional FT-14 switch with black cover can be supplied at no additional charge provided the tenth character in the above style is changed from “C” to “B.” An optional FT-14 switch with lockable clear or black cover can be supplied at no additional charge provided the tenth character is changed from “C” to either “M” (clear shallow), “L” (lockable clear), “R” (lockable black), “W” (lockable clear shallow) or “T” (black slotted cover).

### 6.3 FT-19 and FT-22 test switch assemblies.

The FT-19R and FT-19RX assemblies accommodate up to three FT-1 switches. The FT-19RS and FT-22RS assemblies accommodate up to two FT-1 switches, two FT-14 switches or the combination of one FT-1 and one FT-14 switch.

Each different style number is based on a smart part number system. See page 26–28 for more ordering details.

#### 6.3.1 Terminal connections

The ABB Flexitest switches for FT-19R, FT-19RX, FT-19RS, and FT-22RS assemblies can be ordered with standard (#8) screw or optional stud and nut terminals. The type of terminal connection is represented by the second character of the style number.

#### 6.3.2 Panel height

The 19-inch as well as 22-inch wide mounting panel can be ordered in different rack unit (RU) heights: 2RU, 3RU or 4RU. The 3RU assembly is available with switch positions centered, mounted high or mounted low. The 4RU is available with switches mounted low or high.

#### 6.3.3 Panel color and material

Panels are available in the following colors and materials: brushed finish aluminum; beige (textured surface) steel; light sandalwood (RAL1019) steel; thunder blue (textured) steel; gray (RAL7032 smooth surface) steel; ANSI 61 gray steel; ANSI 70 gray steel; RAL7035 gray steel; black (smooth surface) steel; and white (Corvel 30-1112 high gloss) steel.

For visual representation of the panel colors, please visit <https://ftswitch.apps.us.abb.com/>.

#### 6.3.4 ABB Flexitest switch code numbers (positions A, B and C)

Each FT-1 switch is identified by a unique three-digit code number. FT-14 switches are identified by a unique four-digit code number. These code numbers are required for each of the positions in the assembly (positions A, B and C).

To obtain the FT-1 or FT-14 switch style number and the three- or four-digit code number, refer to the ABB FT-1 configurator at <https://ftswitch.apps.us.abb.com/> or the FT Switch Selection Guide (document 1VAC397062-SG). A cover plate will be provided for unused FT-1 or FT-14 switch positions (A, B or C) by using code number “000” or “0000” respectively.

If a particular arrangement is not listed, contact the ABB Coral Springs factory.

#### 6.3.5 Switch replacement

To add an FT-1 switch in an unused position or to replace a switch in an FT-19R assembly, the required FT-1 switch style(s) will need to be provided. These numbers differ from the individual FT-1 style numbers by including the prefix “R” to represent screw terminals (e.g., R129A501G01) or the prefix “RS” to represent stud-type terminals (e.g., RS129A501G01). For FT-19RX assemblies, provide the required FT-1 switch style with an “R” or “RS” prefix plus the X08 or X10 length suffix (e.g., R129A501G01X10).

It is not necessary to add “R” prefix to the standard style number of FT-1 or FT-14 switches to be used as replacement on FT-19RS assemblies.

#### 6.3.6 Cover

For FT-19R assemblies, the cover field should be left BLANK to order the unit with the standard full-length clear cover. Optional full-length black (A) or clear (N), full-length shallow clear (M), individual black (B), individual deep clear (C), individual shallow clear (H), lockable full-length clear (L) or black (R), lockable full-length shallow clear (W) or full-length black slotted cover (T) can be requested by indicating the assigned letter on the cover field on the smart part number.

The cover field is always required on FT-19RX, FT-19RS and FT-22RS part numbers.

#### 6.3.7 Additional features

When ordering the “flat panel” version, please note this is meant for applications where flush panel or cabinet mounting is required.

# FT-19R

## Flexitest switch assembly

### Typical catalog number

#### Terminal connections

Description	Code
Screw type (standard)	R
Stud and nut type (optional)	S

#### Color and material

Description	Code	Description	Code
Brushed finish aluminum	A	Gray (ANSI 70 smooth surface) steel	H
Beige (textured surface) steel	B	Gray (RAL7035 smooth surface) steel	J
Light sandalwood (RAL1019) steel	D	Black (smooth surface) steel	K
Thunder blue (textured) steel	E	White (corvel 30-1112 high gloss) steel	W
Gray (RAL7032 smooth surface) steel	F		
Gray (ANSI 61 smooth surface) steel	G		

#### Additional features

Description	Code
None	Blank
Flat panel (panel and cabinet mount only)	F

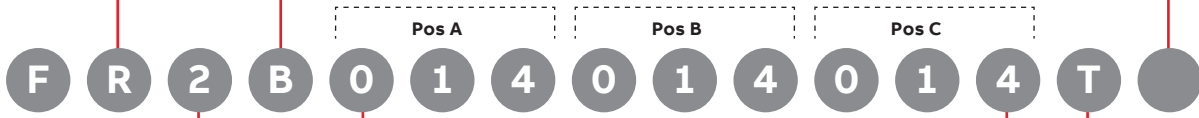

#### Panel height

Description	Code
Two rack units (2RU)	2
Three rack units (3RU), switches centered	3
Three rack units (3RU), switches low	X
Three rack units (3RU), switches high	Y
Four rack units (4RU), switches low	4
Four rack units (4RU), switches high	Z

#### FT-1 switch code numbers

Description	Code
Position A	
Position B	
Position C	
No switch (cover plate provided over switch cutout)	0 0 0
3-digit FT-1 code number	

#### Cover

Description	Code
Full-length clear deep cover (standard)	Blank
Full-length clear deep cover <sup>1</sup>	N
Full-length black cover	A
Full-length clear shallow cover	M
Individual black covers	B
Individual clear deep covers	C
Individual clear shallow covers	H
Full-length black slotted cover with barrier	T
Lockable full-length clear deep cover	L
Lockable full-length black cover	R
Lockable full-length clear shallow cover	W

<sup>1</sup> The cover option "N" only applies when additional features are required. For special configurations, please contact the factory.

96

# FT-19RX

## Flexitest switch assembly

### Typical catalog number

The diagram shows the catalog number FT-R2B014014014NX10 with callouts to various configuration options. The callouts are as follows:

- Terminal connections:** R (Screw type), S (Stud and nut type).
- Color and material:** A (Brushed finish aluminum), B (Beige textured steel), D (Light sandalwood steel), E (Thunder blue textured steel), F (Gray RAL7032 steel), G (Gray ANSI 61 steel), H (Gray ANSI 70 steel), J (Gray RAL7035 steel), K (Black steel), W (White Corvel steel).
- Additional features:** F (Flat panel).
- Panel height:** 2 (2RU), 3 (3RU centered), X (3RU low), Y (3RU high), 4 (4RU low), Z (4RU high).
- FT-1 switch code numbers:** 0 (Position A), 1 (Position B), 4 (Position C), 000 (No switch), 000 (3-digit FT-1 code number).
- Cover:** Blank, N (Full-length clear deep cover<sup>1</sup>), A (Full-length black cover), M (Full-length clear shallow cover), B (Individual black covers), C (Individual clear deep covers), H (Individual clear shallow covers), T (Full-length black slotted cover with barrier), L (Lockable full-length clear deep cover), R (Lockable full-length black cover), W (Lockable full-length clear shallow cover).
- Extended length switches:** X0B (8.25 inches), X10 (10.25 inches).

For special configurations, please contact the factory.

# FT-19RS and FT-22RS

## Flexitest switch assembly

### Typical catalog number

**Assembly type**

Description	Code
19 inch mounting panel	S
22 inch mounting panel	V

**Panel height**

Description	Code
Two rack units (2RU)	2
Three rack units (3RU), switches centered	3
Three rack units (3RU), switches low	X
Three rack units (3RU), switches high	Y
Four rack units (4RU), switches low	4
Four rack units (4RU), switches high	Z

**Color and material**

Description	Code
Brushed finish aluminum	A
Beige (textured surface) steel	B
Light sandalwood (RAL1019) steel	D
Thunder blue (textured) steel	E
Gray (RAL7032 smooth surface) steel	F
Gray (ANSI 61 smooth surface) steel	G

Pos A      Pos B      Pos C

S R 2 B 0 1 4 - N - 4 0 2 5 B

**Terminal connections**

Description	Code
Screw type (standard)	R
Stud and nut type (optional)	S

**Positions A, B, C**

Description	Code
3-digit FT-1 switch code number	0 0 1 - 9 9 9 , A 0 1 - Z 9 9
4-digit FT-14 switch code number	4 0 0 1 - 9 9 9 9
Special equipment code (see table 1, page 30)	S 0 1 - S 9 9
Unused panel position	N
No switch (cover plate provided over FT-1 switch cutout)	0 0 0
No switch (cover plate provided over FT-14 switch cutout)	4 0 0 0

**Cover**

Description	Code
Individual clear deep covers	C
Individual black covers (standard)	B
Lockable individual clear deep cover	L
Lockable individual black cover	R
Individual clear shallow cover	M
Lockable individual clear shallow cover	W
Individual black slotted covers with barriers	T

**Additional features**

Description	Code
None	Blank
8.25 inches extended terminals (FT-1 only)	W
10.25 inches extended terminals (FT-1 only)	X
Flat panel	F
8.25 inches extended terminals (FT-1 only), flat panel	M
10.25 inches extended terminals (FT-1 only), flat panel	A

90

—  
20–24 Possible combinations of FT-1 and FT-14 switches on FT-19RS and FT-22RS assemblies when space for special equipment is not required. Consult the ABB factory for custom configurations.

Fig.	Pos. A	Pos. B	Pos. C
20	FT1	N	FT1
21	FT14	N	FT14
22	FT14	N	FT1
23	FT1	N	FT1
24	FT1	N	N

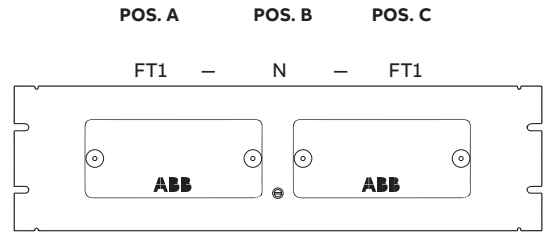

—  
20

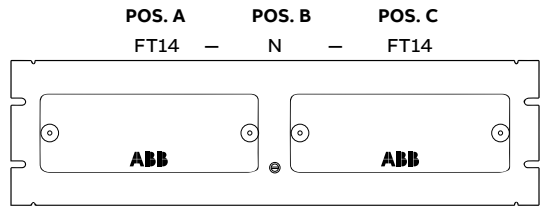

—  
21

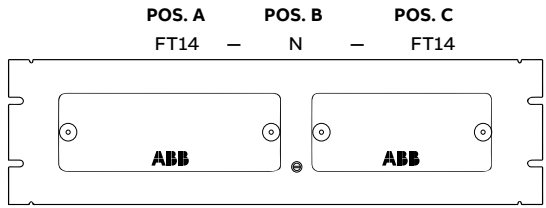

—  
22

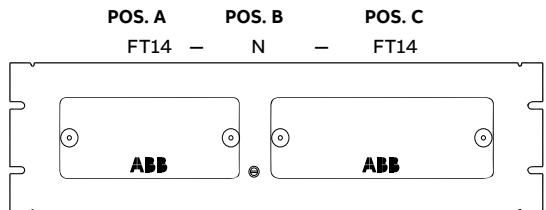

—  
23

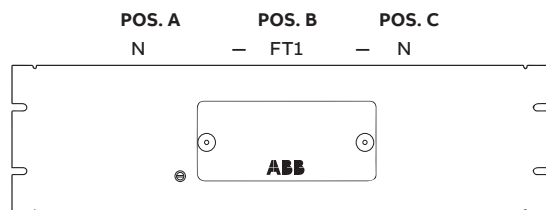

—  
24

25–28 Possible combinations of FT-1 and FT-14 switches on FT-19RS and FT-22RS assemblies when space for special equipment is not required. Consult the ABB factory for custom configurations.

Fig.	Pos. A	Pos. B	Pos. C
25	FT1	FT1	SXX
26	FT1	SXX	FT1
27	SXX	FT1	FT1
28	FT1	N	SXX

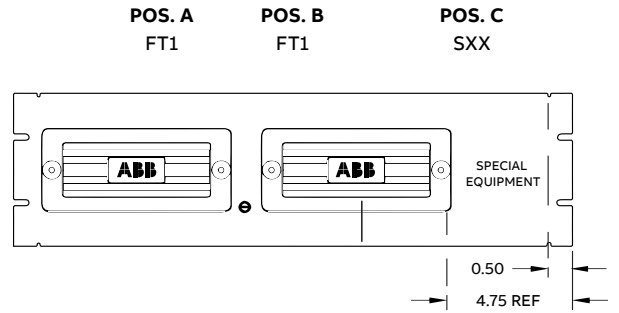

25

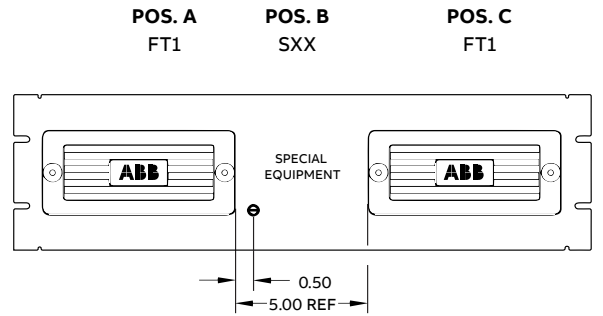

26

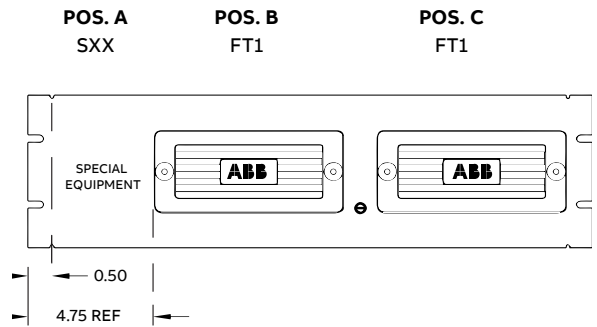

27

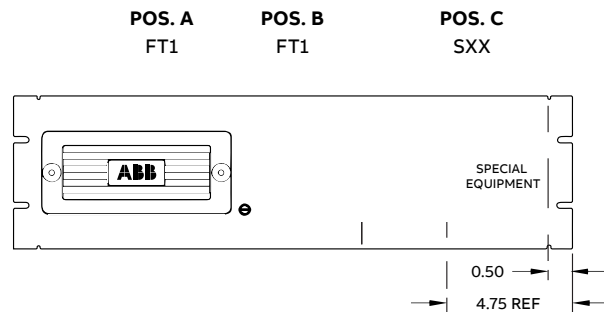

28

Table 5. Available special equipment codes

Code	Detail drawing	Manufacturer	Description
S01	PNL-DRL-S01	-	Toggle switch
S02	PNL-DRL-S02	Electroswitch	Series 24 lock-out relay
S03	PNL-DRL-S03	GE	GE type SBM control switch
S04	PNL-DRL-S04	GE	GE type SB-1 switch
S24	PNL-DRL-S24	Electroswitch	Series 24 control transfer switch

Note: Special equipment not included with assembly.

## Most popular FT switches

Table 6 — FT -1 switch selection guide

Poles	Potential	Current	A	B	C	D	E	F	G	H	I	J	Style number	Code	Options	In-service test plug
10	10	0	P	P	P	P	P	P	P	P	P	P	129A501G01	001	Black cover, screw terminals	129A062G10
10	10	0	T	T	T	T	T	T	T	T	T	T	129A539G01	036	Black cover, screw terminals	129A062G10
10	10	0	P	T	T	T	T	T	T	T	T	T	9688A17G01	584	Black cover, screw terminals	129A062G10
10	10	0	P	P	P	P	P	P	P	P	T	T	1586C42G23	212	Black cover, screw terminals	129A062G10
10	10	0	P	P	P	P	T	T	T	P	P	P	9676A14G01	452	Black cover, screw terminals	129A062G10
10	10	0	T	T	P	P	P	P	P	P	P	P	1586C42G45	262	Black cover, screw terminals	129A062G10
10	4	6	P	P	P	C - C	C - C	C - C	C - C	P			129A514G01	014	Black cover, screw terminals	292B319G23
10	4	6	P	C - C	P	C - C	P	C - C	P				129A528G01	026	Black cover, screw terminals	NONE
10	4	6	C - C	C - C	C - C	P	P	P	P				774B430G20	171	Black cover, screw terminals	NONE
10	4	6	T	T	T	T	C - C	C - C	C - C				498A010G01	065	Black cover, screw terminals	NONE
10	4	6	P	P	P	P	C - C	C - C	C - C				670B197G18	119	Black cover, screw terminals	NONE
10	4	6	T	T	T	C - C	C - C	C - C	T				714B325G32	137	Black cover, screw terminals	292B319G23
10	4	6	C - C	C - C	C - C	T	T	T	T				774B430G24	183	Black cover, screw terminals	NONE
10	3	7	P	P	C	C - C	C - C	C - C	P				129A535G01	033	Black cover, screw terminals	292B319G22
10	2	8	P	C - C	C - C	C - C	C - C	P					129A518G01	018	Black cover, screw terminals	292B319G22
10	2	8	C - C	C - C	C - C	C - C	C - C	P	P				837A407G01	083	Black cover, screw terminals	NONE
10	2	8	C - C	C - C	C - C	C - C	T	T					774B430G22	173	Black cover, screw terminals	NONE
10	0	10	C - C	C - C	C - C	C - C	C - C	C - C					498A020G01	073	Black cover, screw terminals	NONE
8	0	8	,	C - C	C - C	C - C	C - C	,					129A517G01	017	Black cover, screw terminals	292B319G22
8	0	8	X	R - R	R - R	R - R	R - R	R - R	X				9660A84G01	266	Black cover, screw terminals	292B319G22
6	0	6	,	,	,	C - C	C - C	C - C	,				129A516G01	016	Black cover, screw terminals	292B319G23

Table 7 — FT -14 switch selection guide

Poles	Potential	Current	A	B	C	D	E	F	G	H	I	J	K	L	M	N	Style number	Code	Options
14	14	0	P	P	P	P	P	P	P	P	P	P	P	P	P	P	FT4A14T14CN4001	4001	Clear cover, screw terminals
14	14	0	T	T	T	T	T	T	T	T	T	T	T	T	T	T	FT4A14T14CN4018	4018	Clear cover, screw terminals
14	6	8	P	P	P	P	P	P	C - C	C - C	C - C	C - C	C - C				FT4A14T06CN4046	4046	Clear cover, screw terminals
14	6	8	P	P	P	C - C	C - C	C - C	C - C	P	P	P	P	P	P		FT4A14T06CN4044	4044	Clear cover, screw terminals
14	6	8	C - C	C - C	C - C	C - C	C - C	C - C	P	P	P	P	P	P			FT4A14T06CN4068	4068	Clear cover, screw terminals
14	6	8	C - C	C - C	C - C	C - C	C - C	C - C	P	P	P	P	T	T			FT4A14T06CN4035	4035	Clear cover, screw terminals
14	6	8	T	T	T	T	C - C	C - C	C - C	C - C	C - C	T	T				FT4A14T06CN4052	4052	Clear cover, screw terminals
14	4	10	P	P	P	P	C - C	C - C	C - C	C - C	C - C	C - C					FT4A14S04BN4151	4151	Black cover, stud terminals
14	2	12	C - C	C - C	C - C	P	P	C - C	C - C	C - C	C - C						FT4A14S02BN4177	4177	Black cover, stud terminals
14	0	14	C - C	C - C	C - C	C - C	C - C	C - C	C - C	C - C							FT4A14T00CN4063	4063	Clear cover, screw terminals
12	4	8	T	P	Z	W	,	R - R	C - C	7 - 7	,	8 - 8					FT4A12T04CN4163	4163	Clear cover, screw terminals
11	3	8	P	P	P	,	C - C	C - C	C - C	,	C - C	,					FT4A11S03BN4127	4127	Black cover, stud terminals

The above are the most popular FT switch configurations. For more styles, please visit <https://ftswitch.apps.us.abb.com/>

Table 8 — FT -19R switch assemblies





Style number	Position A	Position B	Position C	Options
FR3G001001001	001	001	001	3RU (centered), steel, ANSI 61 gray, screw terminals
FR3G171001001	171	001	001	3RU (centered), steel, ANSI 61 gray, screw terminals
FR2G001001001	001	001	001	2RU, steel, ANSI 61 gray, screw terminals
FR3H014001001	014	001	001	3RU (centered), steel, ANSI 70 gray, screw terminals
FR3H001001001	001	001	001	3RU (centered), steel, ANSI 70 gray, screw terminals
FR3G073001001	073	001	001	3RU (centered), steel, ANSI 61 gray, screw terminals
FRXG001001001	001	001	001	3RU (low), steel, ANSI 61 gray, screw terminals
FR3G014001001	014	001	001	3RU (centered), steel, ANSI 61 gray, screw terminals
FR3G001001262	001	001	262	3RU (centered), steel, ANSI 61 gray, screw terminals
FR3G183001262	183	001	262	3RU (centered), steel, ANSI 61 gray, screw terminals
FR4G001001001	001	001	001	4RU, steel, ANSI 61 gray, screw terminals
FR3G073212036	073	212	036	3RU (centered), steel, ANSI 61 gray, screw terminals
FR3G183001001	183	001	001	3RU (centered), steel, ANSI 61 gray, screw terminals
FR4G171001001	171	001	001	4RU, steel, ANSI 61 gray, screw terminals
FR3G083001001	083	001	001	3RU (centered), steel, ANSI 61 gray, screw terminals
FR3G083452000	083	452	000	3RU (centered), steel, ANSI 61 gray, screw terminals
FR2G014001001	014	001	001	2RU, steel, ANSI 61 gray, screw terminals
FR3G036036036	036	036	036	3RU (centered), steel, ANSI 61 gray, screw terminals
FR2G026001001	026	001	001	2RU, steel, ANSI 61 gray, screw terminals
FR3G026001026	026	001	026	3RU (centered), steel, ANSI 61 gray, screw terminals
FR3G171171001	171	171	001	3RU (centered), steel, ANSI 61 gray, screw terminals
FR2G001001000	001	001	000	2RU, steel, ANSI 61 gray, screw terminals
FR2G001000000	001	000	000	2RU, steel, ANSI 61 gray, screw terminals
FR3H014014014	014	014	014	3RU (centered), steel, ANSI 70 gray, screw terminals
FR3G026001001	026	001	001	3RU (centered), steel, ANSI 61 gray, screw terminals

Table 9 — FT -19RS switch assemblies

Style number	Position A	Position B	Position C	Options
SR2J183-N-183B	183	N	183	19-inch mounting panel, screw terminals, 2RU, RAL7035 gray, steel
SR2J4037-N-4001CF	4037	N	4001	19-inch mounting panel, screw terminals, 2RU, RAL7035 gray, steel
SR2JN-001-1NB	N	001	N	19-inch mounting panel, screw terminals, 2RU, RAL7035 gray, steel
SR3A014-N-001CF	014	N	001	19-inch mounting panel, screw terminals, 3RU (centered), brushed finish aluminum, individual clear covers, flat panel
SR3A036-S02-000C	036	S02	000	19-inch mounting panel, screw terminals, 3RU (centered), brushed finish aluminum, individual clear covers, special equipment
SR3G001-N-000C	001	N	000	19-inch mounting panel, screw terminals, 3RU (centered), ANSI 61 gray, steel, individual clear covers
SR2JN-001-NB	N	001	N	19-inch mounting panel, screw terminals, 2RU, RAL7035 gray, steel, standard individual black covers
SR2K014-N-001B	014	N	001	19-inch mounting panel, screw terminals, 2RU, black smooth surface, steel, standard individual black covers
SR3G001-N-001B	001	N	001	19-inch mounting panel, screw terminals, 2RU, ANSI 61 smooth surface, steel, standard individual black covers

The above are the most popular FT switch configurations. For more styles, please visit <https://ftswitch.apps.us.abb.com/>

# 7. Test plug and accessories ordering information

Test plugs	Description	Style number
	In-service series test plug (order to match Flexitest FT-1 switch arrangement or FT relay case)	Reference <a href="https://ftswitch.apps.us.abb.com/">https://ftswitch.apps.us.abb.com/</a> data sheet
	Standard individual current circuit test plug — leads not included	7B4618G04
	SafePlug — individual current circuit test plug with open CT protection — leads not included	1VAC391001P001
	Ergonomic separate source test plug (10-position) Note: Test plug style # 1164046 is recommended for electromechanical relay testing	1509B01G01
	Separate source test plug (14-position)	1508B86G01





FT test kit (Includes ABB bag)	Items in test kit 9688A68G25	Rated voltage	Rated current
	1 red 6-ft. safety patch cord with retractable-sleeve banana plug on both ends	600 V DC	32 A
	1 black 6-ft. safety patch cord with retractable-sleeve banana plug on both ends	600 V DC	32 A
	1 red 10-ft. UTP cable with RJ-45 male connector on both ends	600 V	30 A
	1 red safety plug-on test probe	1000 V	10 A
	1 black safety plug-on test probe	1000 V	10 A
	1 red safety plug-on alligator test clip	1000 V	10 A
	1 black safety plug-on alligator test clip	1000 V	10 A
	FT-1 ergonomic separate source test plug — 1509B01G01	600 V	30 A
	FT individual series test plug — 7B4618G04	600 V	30 A

FT test kit (Includes ABB bag)	Items in test kit 9688A68G26	Rated voltage	Rated current
	1 red 6-ft. safety patch cord with retractable-sleeve banana plug on both ends	600 V DC	32 A
	1 black 6-ft. safety patch cord with retractable-sleeve banana plug on both ends	600 V DC	32 A
	1 red 10-ft. UTP cable with RJ-45 male connector on both ends	600 V	30 A
	1 red safety plug-on test probe	1000 V	10 A
	1 black safety plug-on test probe	1000 V	10 A
	1 red safety plug-on alligator test clip	1000 V	10 A
	1 black safety plug-on alligator test clip	1000 V	10 A
	FT-1 ergonomic separate source test plug — 1509B01G01	600 V	30 A
	FT individual current circuit test plug with open CT protection — 1VAC391001P001	600 V	20 A

Covers		FT-1	FT-14	FT-19R
	Standard individual shallow cover with thumb nuts — black	128A973G01	128A973G05	9683A78G06
	Standard individual shallow cover with thumb nuts — clear	9669A64G01	9669A64G03	9683A78G07
	Standard individual deep cover with thumb nuts — clear	9676A32G01	9676A32G02	9683A78G01
	Full-length shallow cover with thumb nuts — black	—	—	9676A28G06
	Full-length deep cover with thumb nuts — clear	—	—	9676A28G01
	Lockable shallow cover with thumb nuts and bracket — black	9669A49G01	9669A49G07	—
	Lockable shallow cover with thumb nuts and bracket — clear	9669A49G05	9669A49G06	—
	Lockable deep cover with thumb nuts and bracket — clear	9669A49G02	9669A49G04	—
	Full-length shallow cover with thumb nuts — clear	—	—	9676A28G09
	Lockable full-length shallow cover with thumb nuts and bracket — clear	—	—	9669A52G04
	Lockable full-length shallow cover with thumb nuts and bracket — black	—	—	9669A52G03
	Lockable full-length deep cover with thumb nuts and bracket — clear	—	—	9669A52G01
	Slotted cover with barrier and thumb nuts — black	6097B95G01	6097B95G02	6097B95G03

Interlocking bars		FT-1	FT-14
	2 positions	1270547	9669A19G02
	3 positions	1164048	9669A19G03
	4 positions	02C9834G03	9669A19G04
	5 positions	02C9834G04	9669A19G05
	6 positions	02C9834G06	9669A19G06
	7 positions	-	9669A19G07
	8 positions	02C9834G07	9669A19G08
	10 positions	02C9834G05	9669A19G10
	14 positions	-	9669A19G14

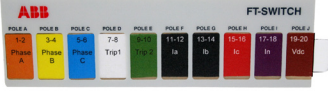
Mounting and wiring material	Kit description	Style number
	FT-19R mounting kit - (2) cover stud, (4) gold screw, (1) ground screw	2A18897G01
	cover stud kit - (20) cover studs	2A18897G02
	FT1 screw terminal - (2) barrel nut, (2) lockwasher (BN), (20) screw	9660A87G02
	FT1 stud terminal - (2) barrel nut, (2) lockwasher (BN), (20) nut, (20) washer, (20) lockwasher	9660A87G06
	FT-1F screw terminal - (20) screw, (4) screw (MTG)	9660A87G10
	FT-1F stud terminal - (20) washer, (20) lockwasher, (20) nut, (4) screw (MTG)	9660A87G11
	FT-14 screw terminal - (2) barrel nut, (2) lockwasher (bn), (28) washer, (28) lockwasher, (28) nut	9660A87G12
	FT-14 stud terminal - (2) barrel nut, (2) lockwasher (bn), (28) washer, (28) lockwasher, (28) nut	9660A87G13
	FT-19R screw terminal - (20) screw, (1) nut, (1) lockwasher	9660A87G04
	FT-19R stud terminal - (20) washer, (20) lockwasher, (20) nut, (1) lockwasher GND, (1) lockwasher 1E	9660A87G08

Miscellaneous		Style number
	FT-1 and FT-14 nut driver for stud and nut terminals	877A821G02
	Unistrut adapter plate for rail mounting of FT-1F	9666A15H01
	Label holder Sleeve (gloss polycarbonate) for FT-1 SW *To create and print custom labels, please use the template in the downloads section at this link.	1506B81H01
	Banana thumbnut knobs for FT-14 separate source and FT-1 in-service series test plugs. Test plug knobs replace all older design knobs. The knobs have a 10-32 threaded brass insert that accommodates all types of test set leads and lugs.	9683A91G02

Visible pole markers (VPMs) create a visual sign that can be seen locally or from a distance to alert FT Flexitest switch users to a specific pole having been intentionally or inadvertently left open during testing and maintenance. The new VPM provides a visible indication to the user to make sure the subject poles are either in the open or closed state as required.

The VPM is a snap-on pole handle cover easy to install over the existing handle and is provided in nine standard colors. For example, a fluorescent orange VPM attached to a standard black handle allows for visual indication of the pole being left open. The VPM can be affixed to any pole handle that is essential to the power system operation. VPM can also be used to mark a switch pole already installed with a different color for ease of circuit identification.

**Visible pole marker**

Bag of quantity ten

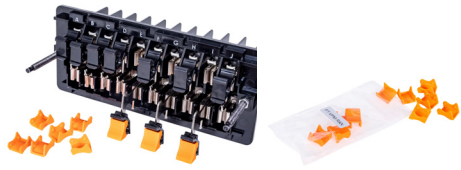

Visible pole marker installed on FT Flexitest switch handles

**Color**

**Style number**

Black	FT-VPM-BLK
Red	FT-VPM-RED
Green	FT-VPM-GRN
Yellow	FT-VPM-YEL
Blue	FT-VPM-BLU
White	FT-VPM-WHT
Purple	FT-VPM-PUR
Brown	FT-VPM-BRN
Orange	FT-VPM-RAN

**Visible pole marker (VPM) installation and removal**

To install, orient the VPM on top of the switch handle with the textured grips aligned as shown in Figure 29A. Press down on top of the VPM until it snaps into place as shown in Figure 29B.

For removing, insert a thin tool under the narrow front edge of the VPM and pry loose as shown in Figure 29C.

29 Illustration of VPM installation and removal

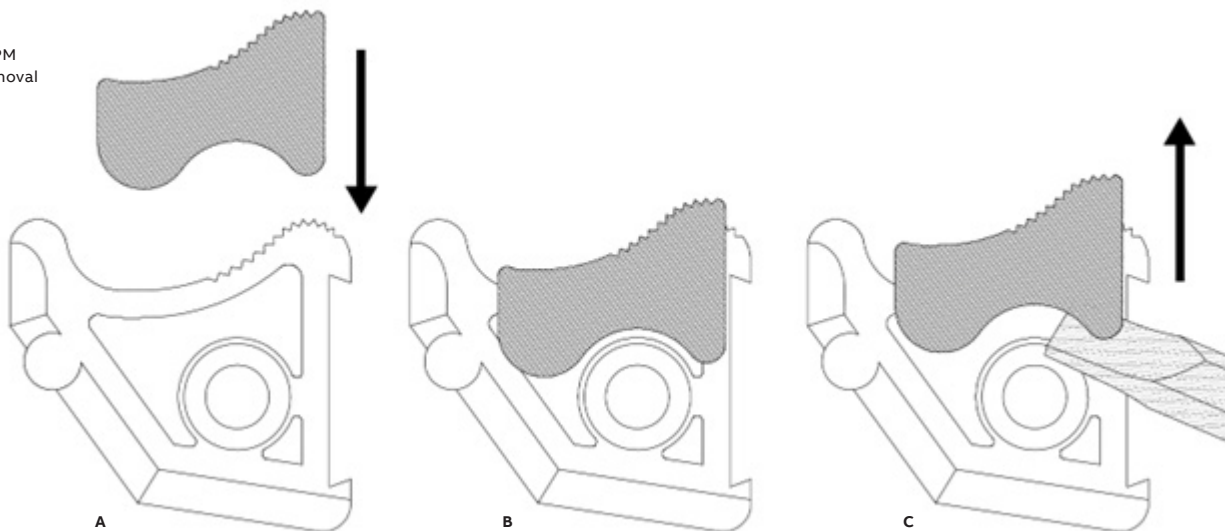





# 8. FT switch covers



Covers	Description	Style number
	FT-1 standard individual shallow cover with thumb nuts — black	128A973G01
	FT-1 standard individual shallow cover with thumb nuts — clear	9669A64G01
	FT-1 standard individual deep cover with thumb nuts — clear	9676A32G01
	FT-14 standard individual shallow cover with thumb nuts — black	128A973G05
	FT-14 standard individual shallow cover with thumb nuts — clear	9669A64G03
	FT-14 standard individual deep cover with thumb nuts — clear	9676A32G02

Covers	Description	Style number
	FT-19R individual standard individual shallow cover with thumb nuts and cover studs — black	9683A78G06
	FT-19R individual standard individual shallow cover with thumb nuts and cover studs — clear	9683A78G07
	FT-19R individual standard individual deep cover with thumb nuts and cover studs — clear	9683A78G01
	FT-19R full-length shallow cover with thumb nuts — black	9676A28G06
	FT-19R full-length shallow cover with thumb nuts — clear	9676A28G09
	FT-19R full-length deep cover with thumb nuts — clear	9676A28G01

**FT cover shield**

Covers	Description	Style number
	FT-1 cover shield individual shallow cover with thumb nuts — black	128A973G09
	FT-1 cover shield individual shallow cover with thumb nuts — clear	9669A64G05
	FT-14 cover shield individual shallow cover with thumb nuts — black	128A973G10
	FT-14 cover shield individual shallow cover with thumb nuts — clear	9669A64G06

**FT slotted cover**

Covers	Description	Style number
	FT-1 slotted cover with thumb nuts, barrier and hardware to mount barrier — black	6097B95G01
	FT-14 slotted cover with thumb nuts, barrier and hardware to mount barrier — black	6097B95G02
	FT-19R full-length slotted cover with thumb nuts, barrier and hardware to mount barrier — black	6097B95G03

—  
30 FT-14 shallow clear cover shield hanging from external tabs on a test switch

—  
31 FT-14 shallow clear cover shield inserted into the test switch by using the internal bosses

—  
32 FT-1 shallow black cover shield hanging from external tabs with separate source test plug inserted into the test switch

### Cover shield installation

The cover shield is easy to install and remove while being a safeguard for “hot” blades. The ABB separate source test plug can be inserted into the FT switch while keeping hot blades isolated, providing safety during necessary testing. Loose covers can be secured easily with the user having no place to put them.

The cover shield is available in clear and black shallow thermoplastic material and can replace existing covers for both FT-1 (10 pole) and FT-14 (14 pole) switches.

Install the cover shield by holding each end and evenly insert the external tabs onto the existing cover mounting posts. The separate source test plug can now be inserted into the FT switch for safe testing. Internal bosses can be used to hold the cover in place over the knife blades but does not allow for testing. The cover shield can be removed easily in the same manner.



30

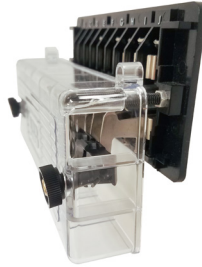

31



32

## FT slotted cover

- 33 FT-1 / FT-14 slotted cover with barrier assembly
- 34 FT-19R slotted cover with barrier assembly
- 35 FT-1 switch with slotted cover installed and labeled hanging tags
- 36 FT-1 switch with slotted cover removed with labeled hanging tags
- 37 FT-1 switch with slotted cover and barrier installed

### Slotted cover and barrier installation

The new slotted cover allows the user to label each individual switch with a hanging tag for ease of circuit identification and to ensure correct operation of the power system. The slotted covers include a removable protective barrier that acts as a safeguard for “hot” blades and is easy to install and remove.

The slotted covers are available in shallow black thermoplastic material and can replace existing covers for FT-1 (10 pole), FT-14 (14 pole) and FT-19R rack-mounted ABB Flexitest switches. If the slotted cover is ordered as an individual item, the protective barrier can be installed over the cover mounting posts with the included hardware.

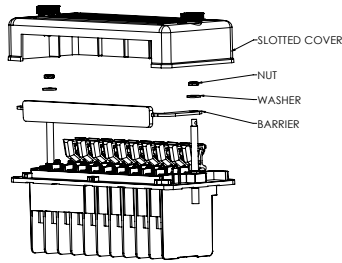

33

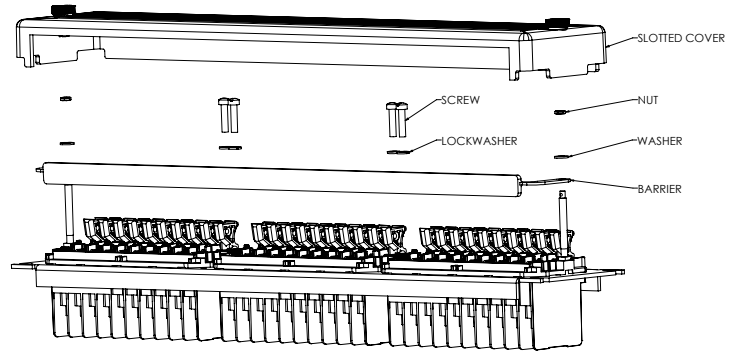

34



35



36



37

---

## 9. Warranty and diagrams

All ABB Flexitest switches and assemblies are backed by a 12-year warranty. The quality of ABB products is based on years of experience and rigorous quality testing programs.



38 FT-1 and FT-1X switch  
outline and drilling plan

**Outline**

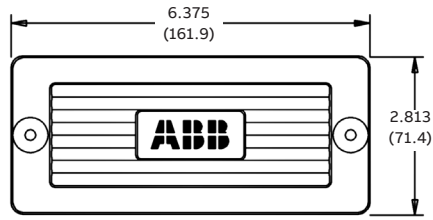

Fig. 1 FT-1 with black cover and clear shallow cover

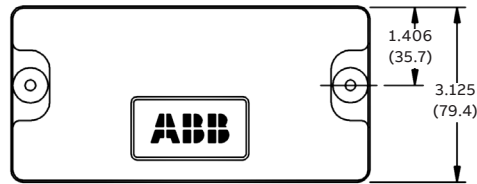
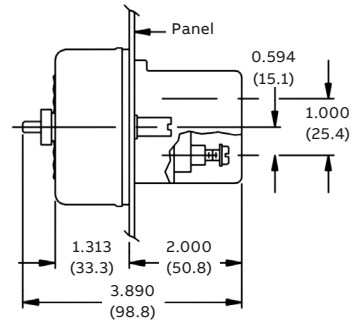
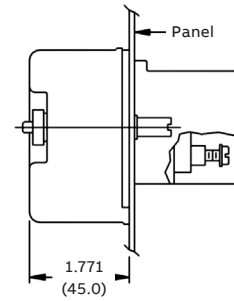
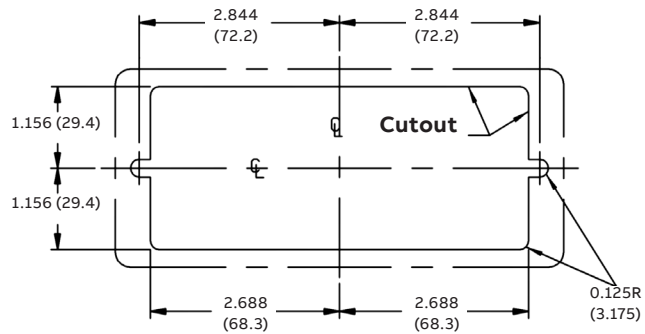

Fig. 2 FT-1 with clear deep cover. Otherwise same as figure 1.



**Drilling plan**



**FT-1X**

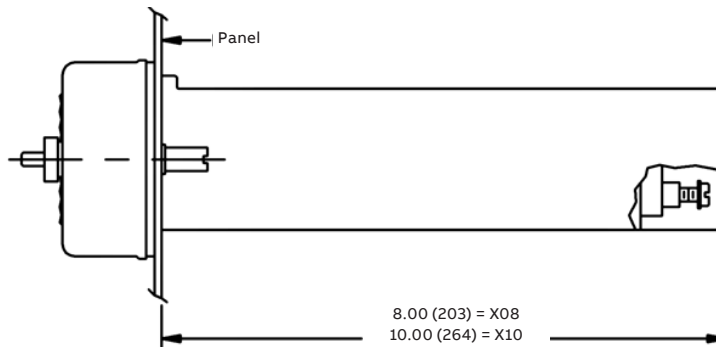

Otherwise same as figure 1.

39 FT-1F switch outline and drilling plan

**Outline**

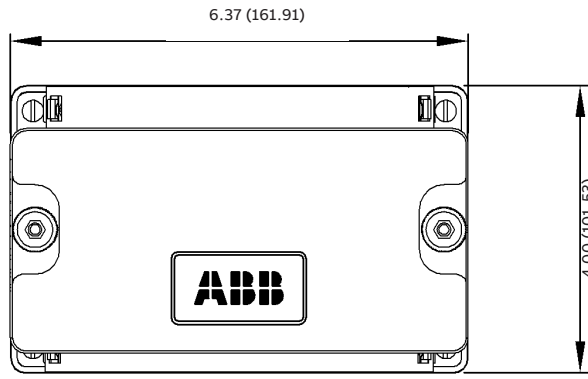
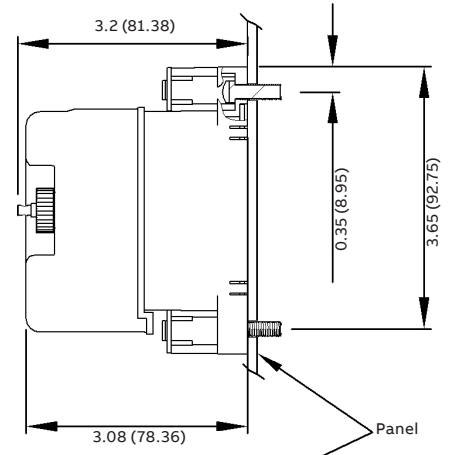

Fig. 1 FT-1F with clear deep cover



Terminal cover removed to show detail

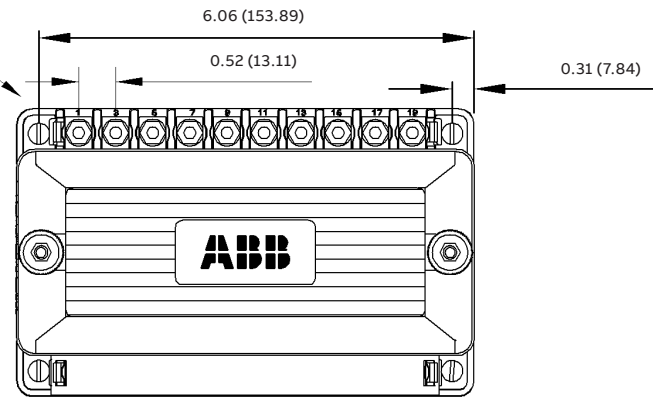
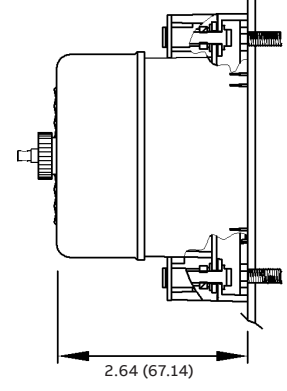
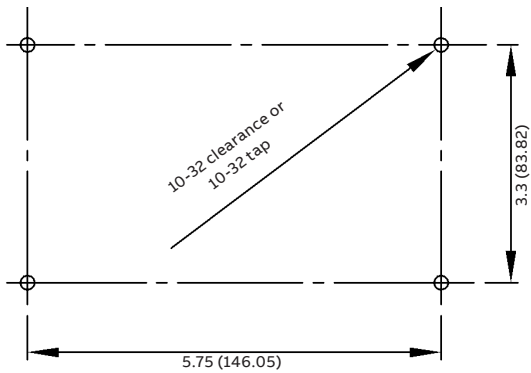

Fig. 2 FT-1F with black and clear shallow cover



**Drilling plan**



—  
40 FT-14 switch outline  
and drilling plan

**Outline**

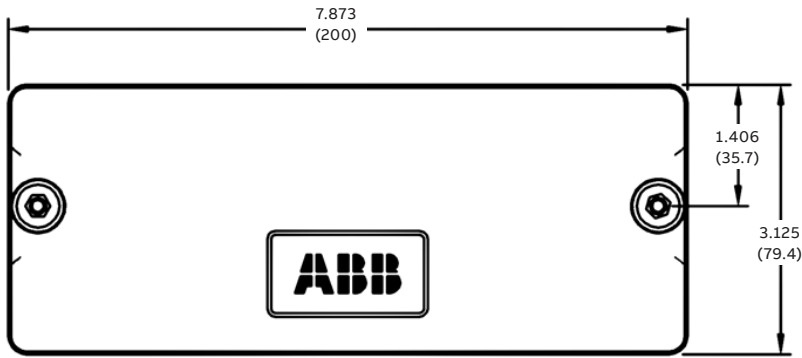
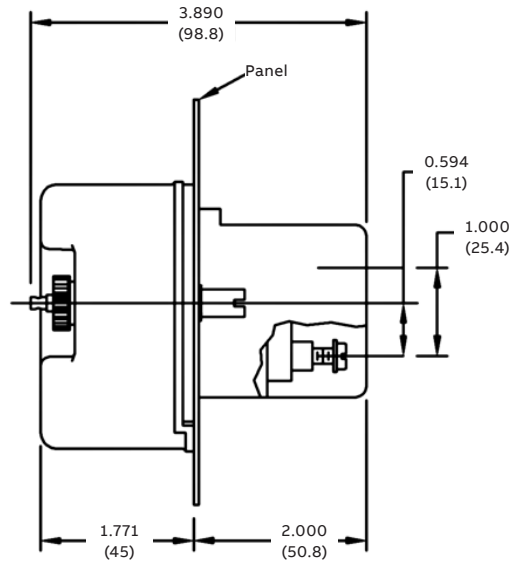
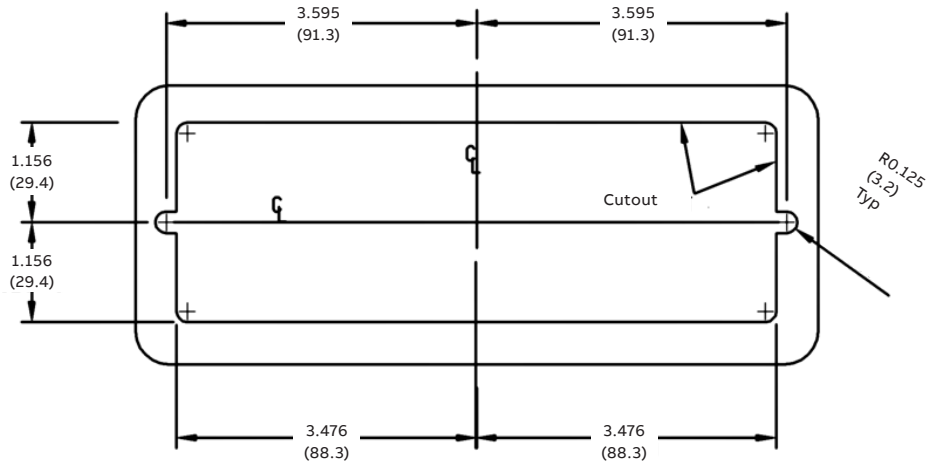

Fig. 1 FT-14 with clear deep cover



**Drilling plan**



—  
40

41 FT-14 shallow cover

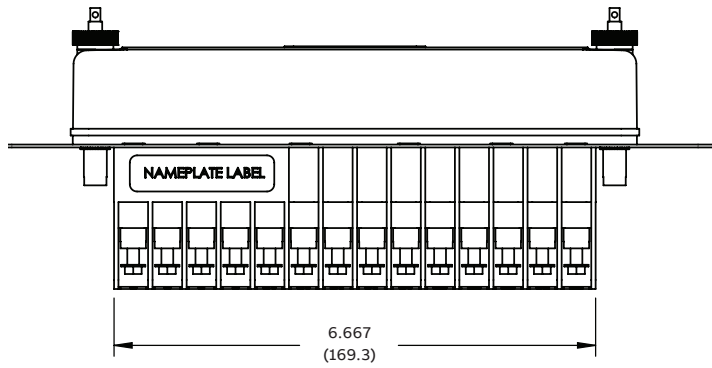
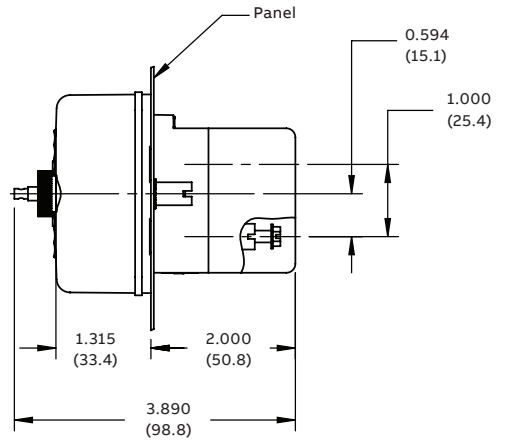
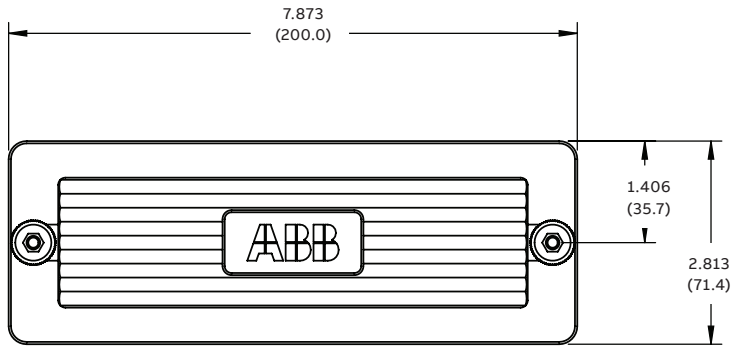

42 FT-19R

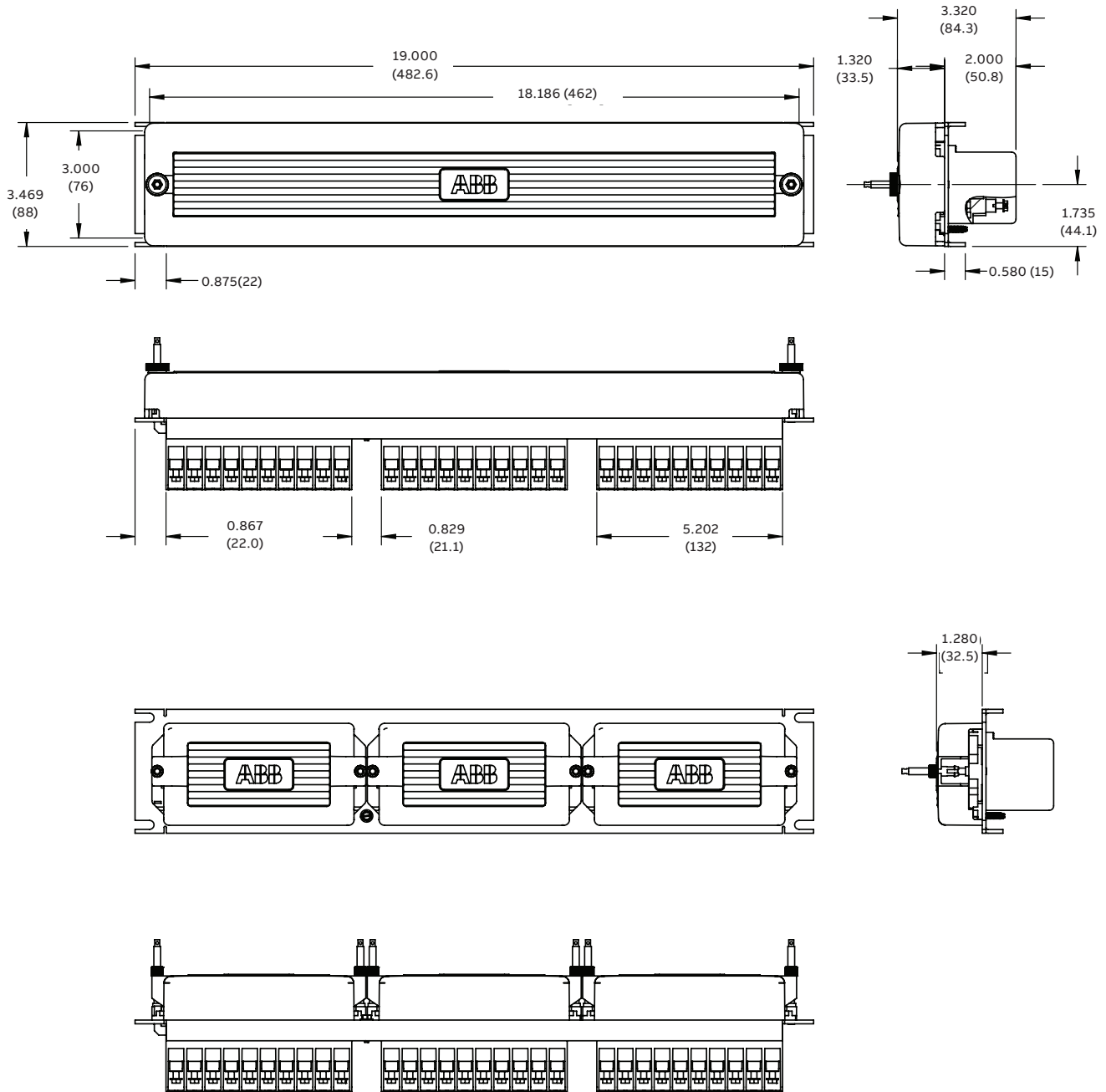

09

42

—  
42 FT-19R (continued)

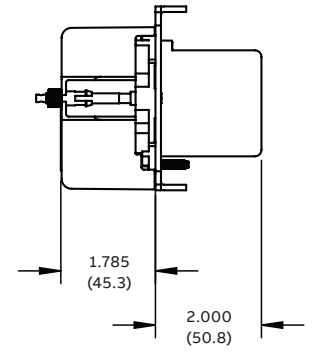
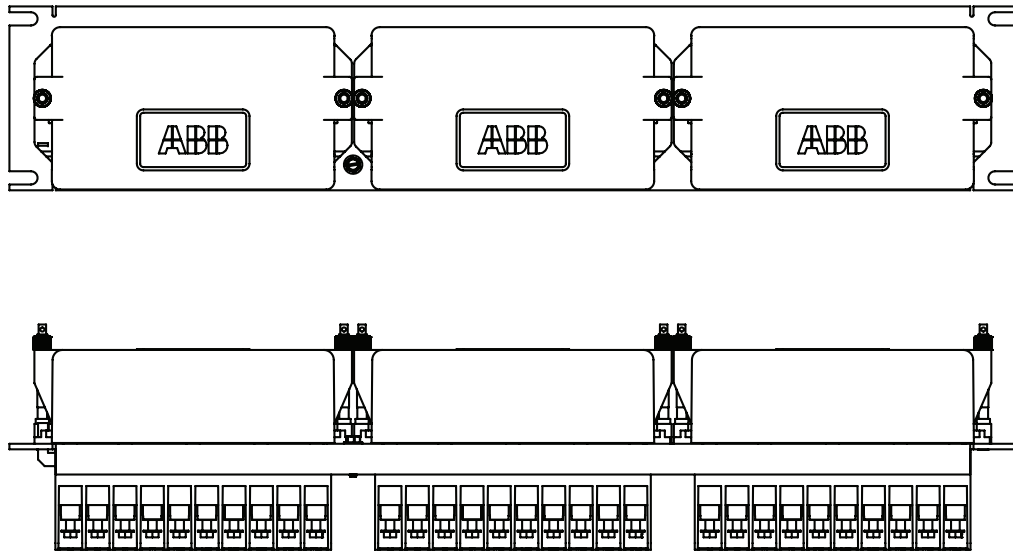

—  
42

43 FT-19R dimensions and layout for rack mounting

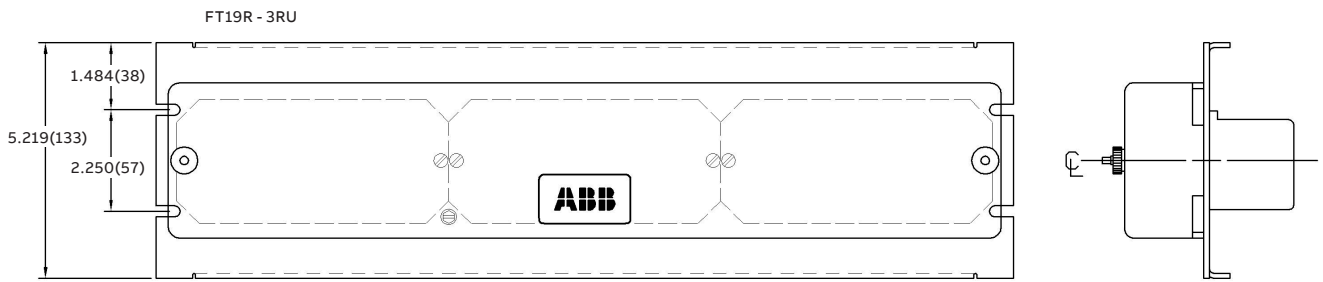
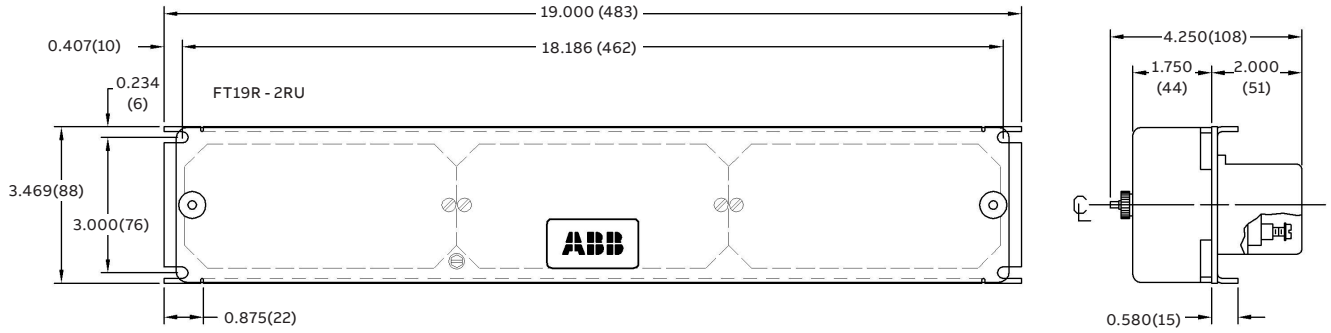

(Otherwise same as 2RU)

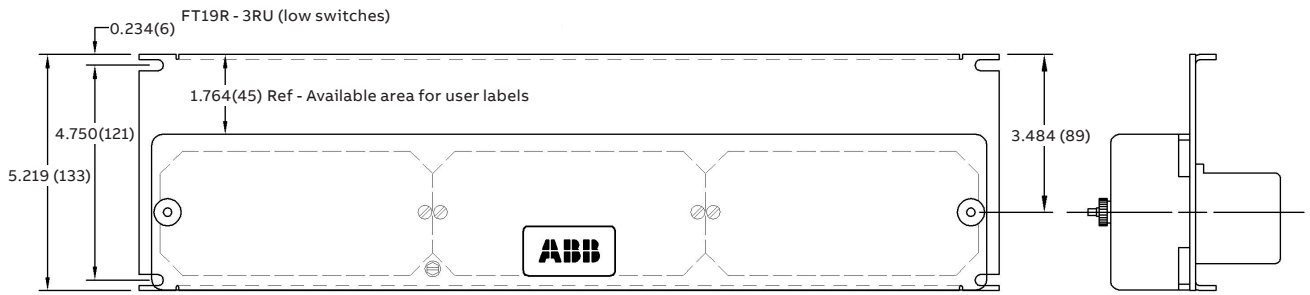

Rotate this figure for 3RU with high switches  
(Otherwise same as 2RU)



Rotate this figure for 4RU with high switches  
(Otherwise same as 2RU)

44 Outline and drilling plan for FT-19R with flat panels (no rolled edges), rack or flush mounting for panels or cabinets

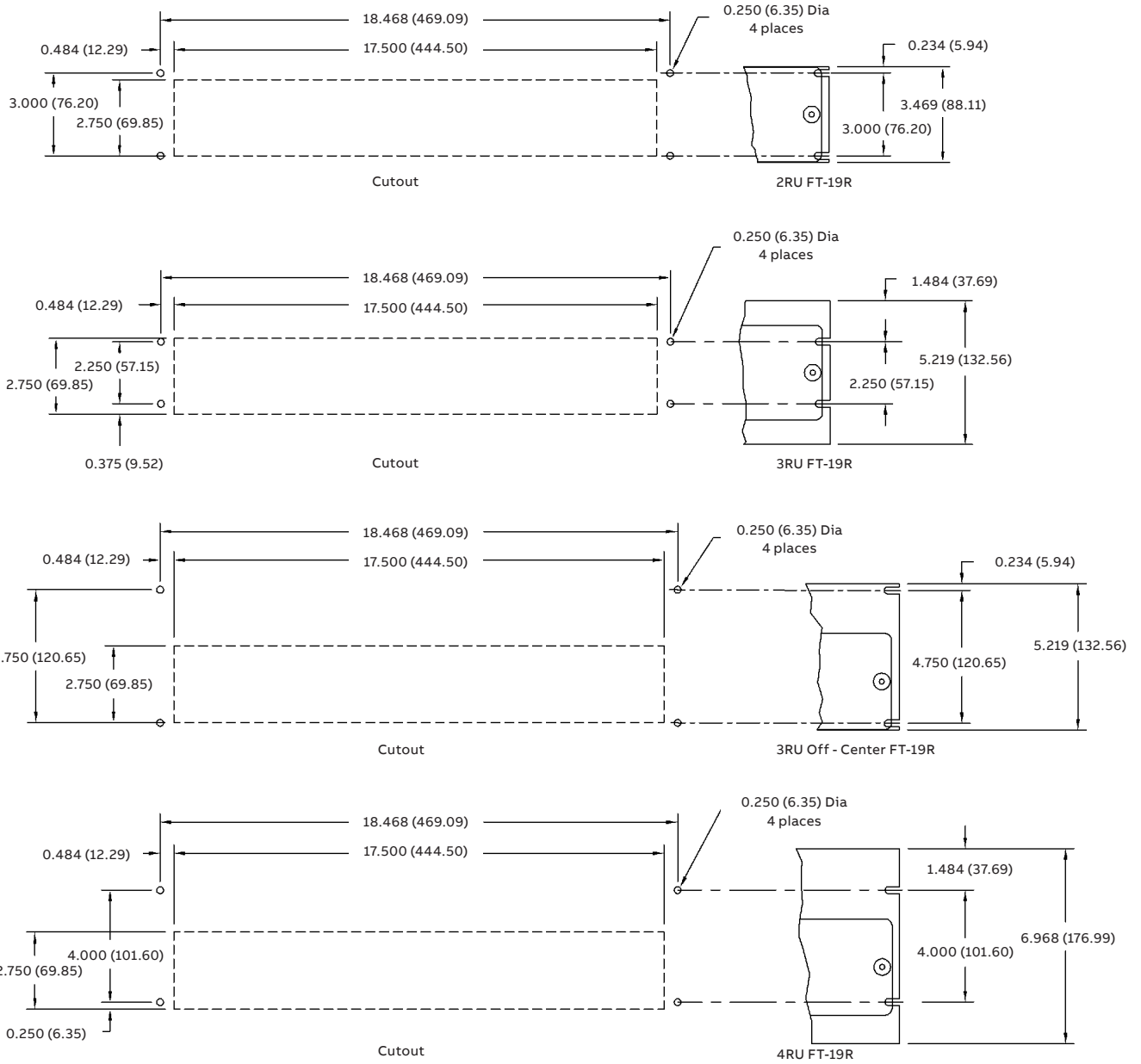

Ref.:  
 Dimensions inches (mm)  
 All figures show front view FT19R panels and cutouts

—  
45 FT-19RS

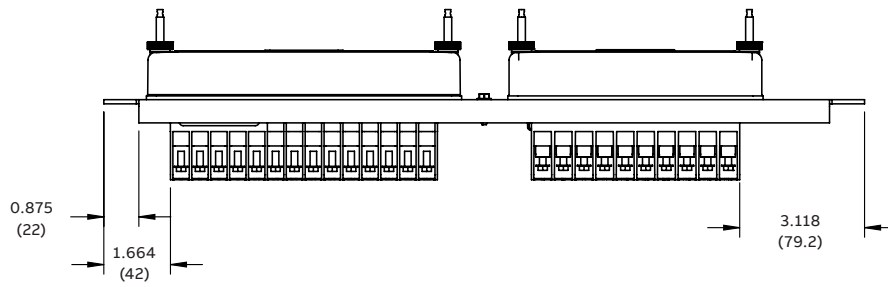
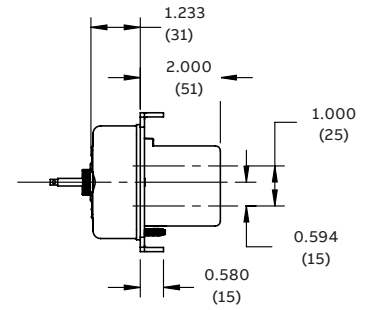
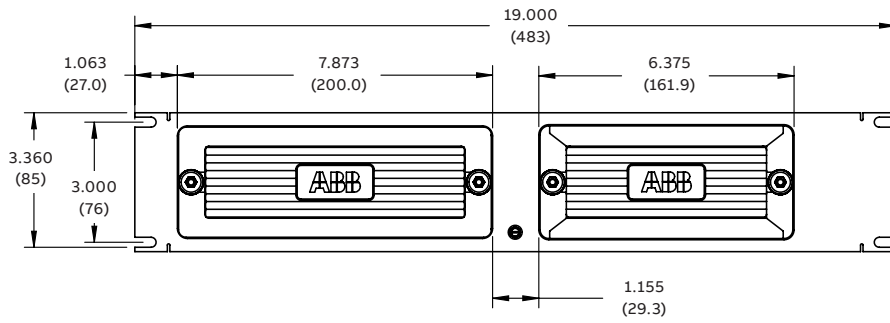

—  
45

46 FT-22RS  
dimensions  
and layout for  
rack mounting

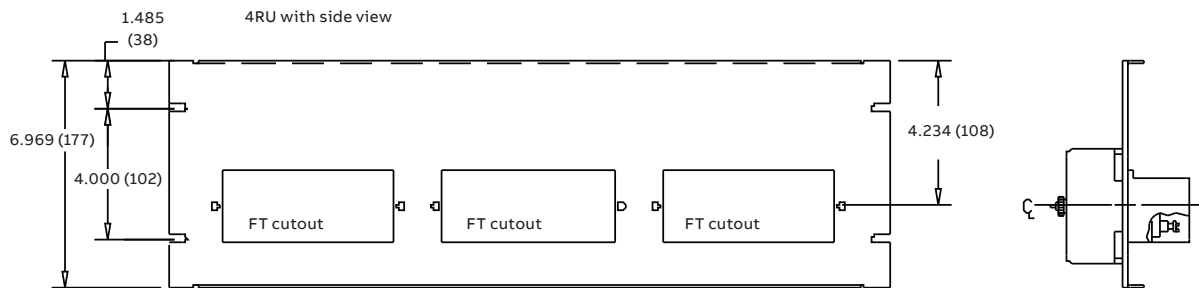
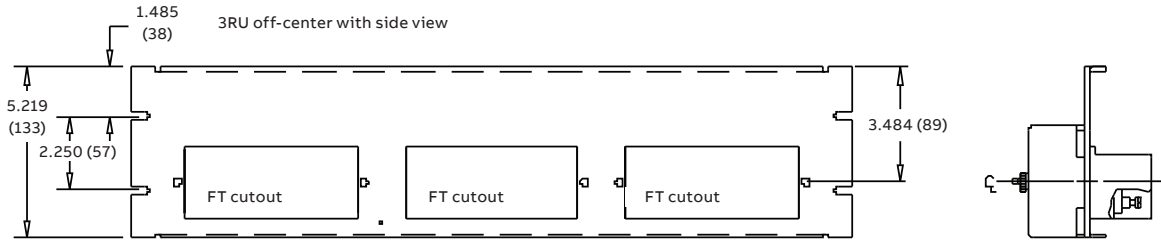
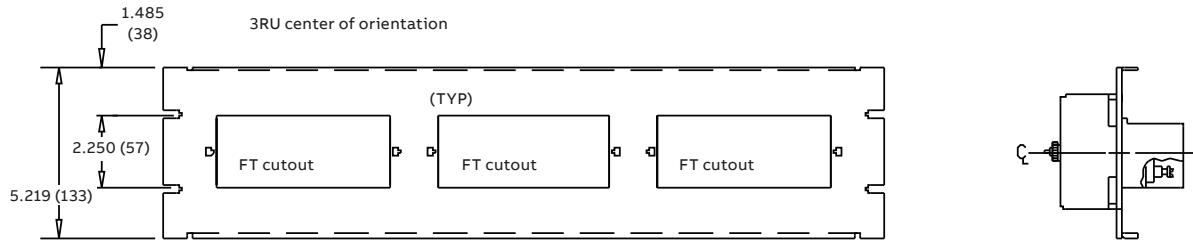
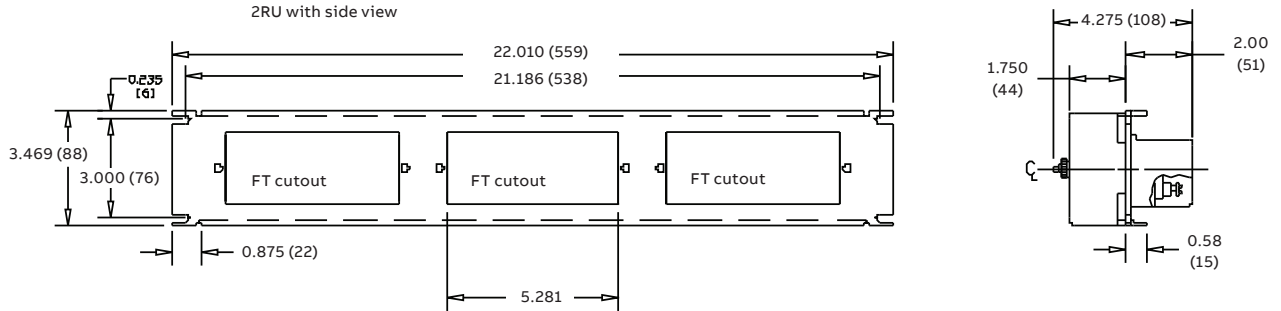

47 Outline and drilling plan for FT-22RS with flat panels (no rolled edges), rack or flush mounting for panels or cabinets

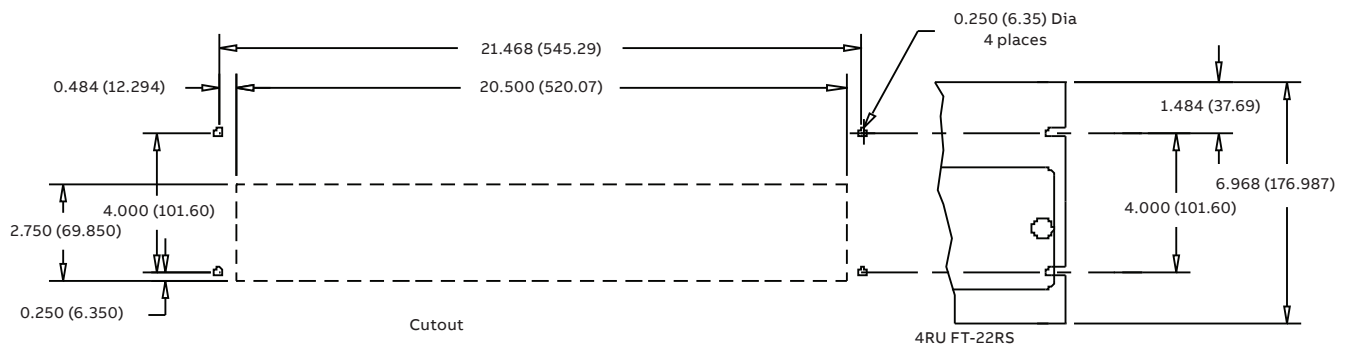
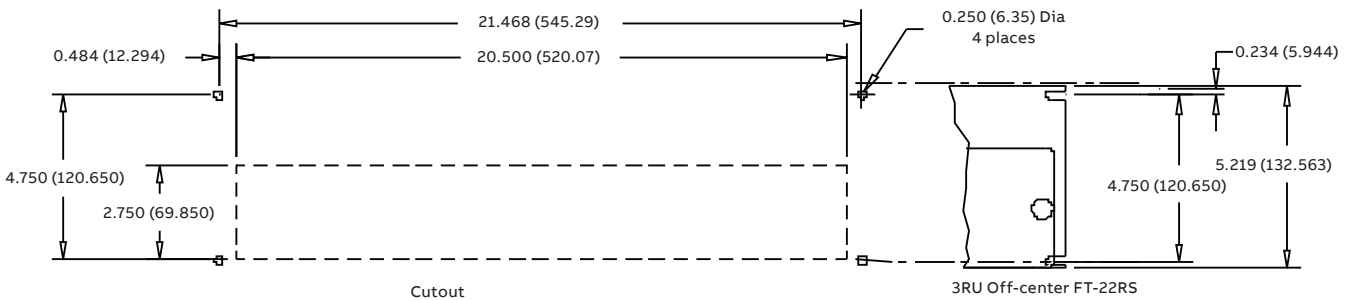
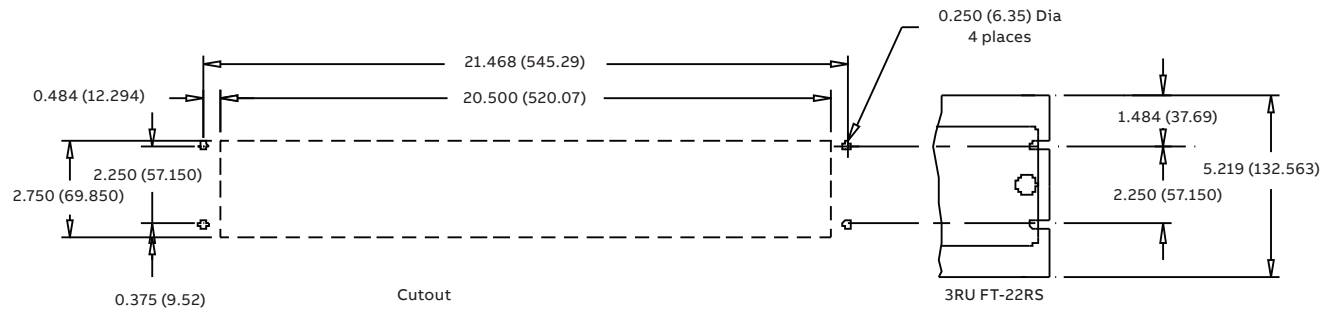
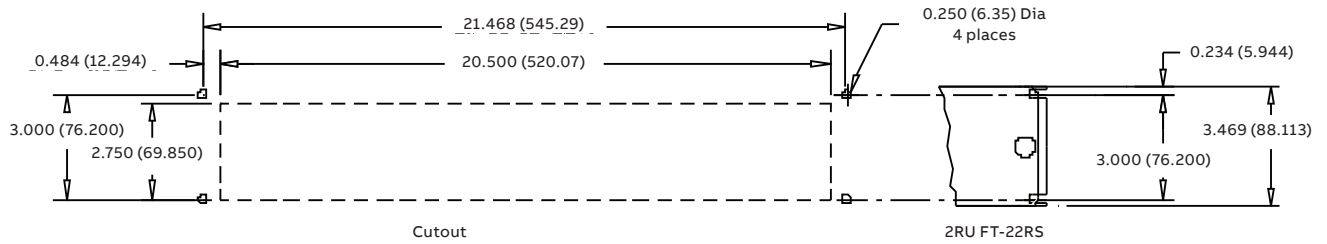

48 Typical FT-1 switch connection schematic

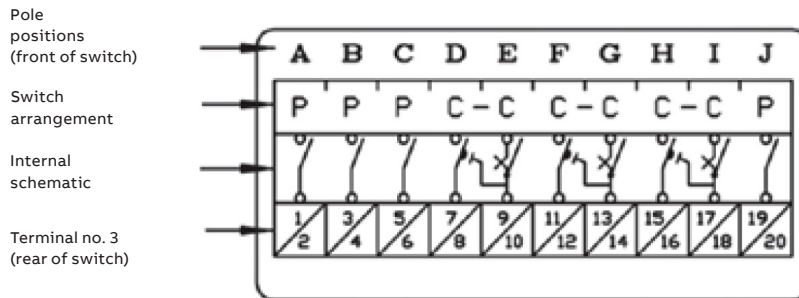
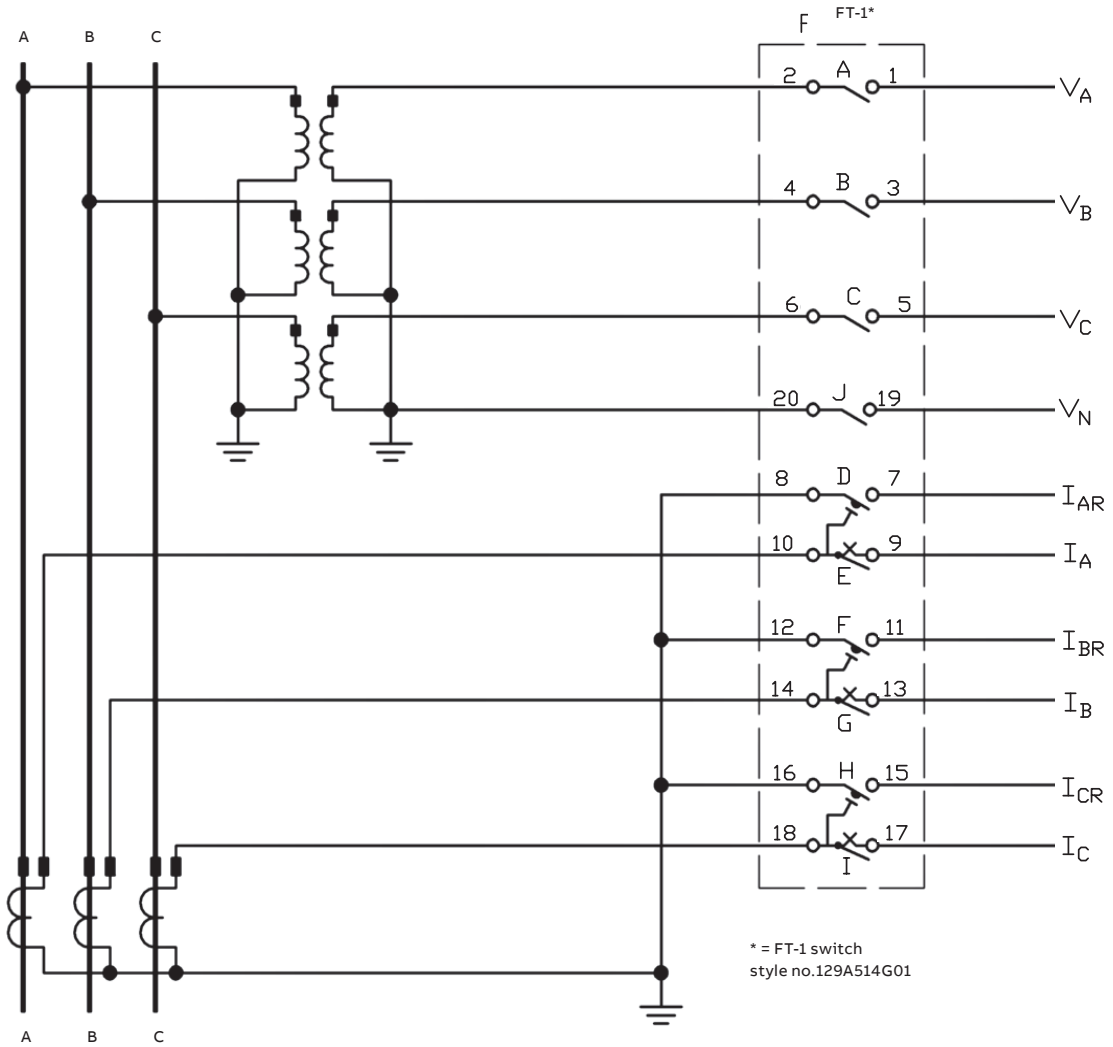

FT-1 style no.129A514G01 (switch layout)

49 FT-1 switch  
connection schematic

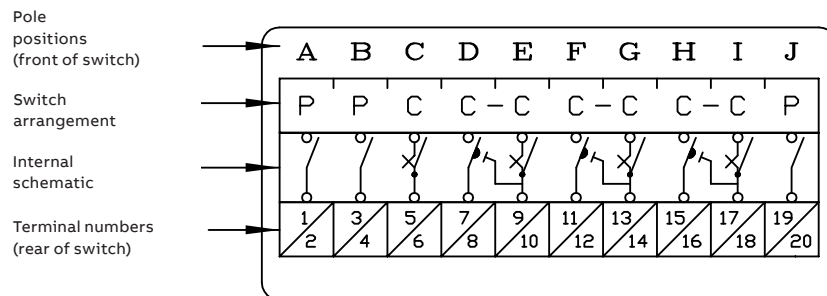
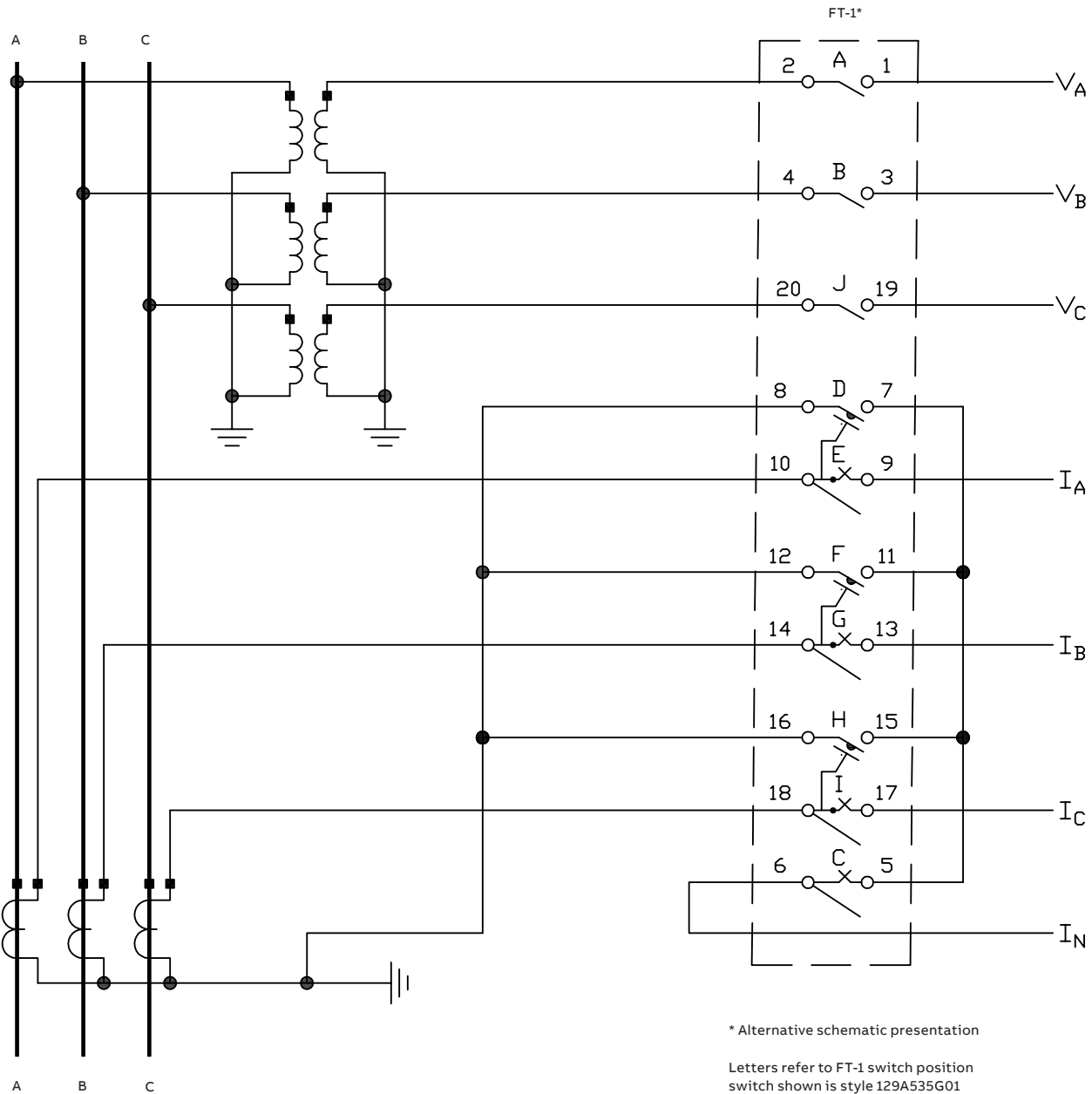

Dimensions inches (mm)

50 FT-14D with combi sensor and REF615 sensor relay with optional ground CT

51 FT-14D with combi sensors and REF615 sensor relay with optional potential poles

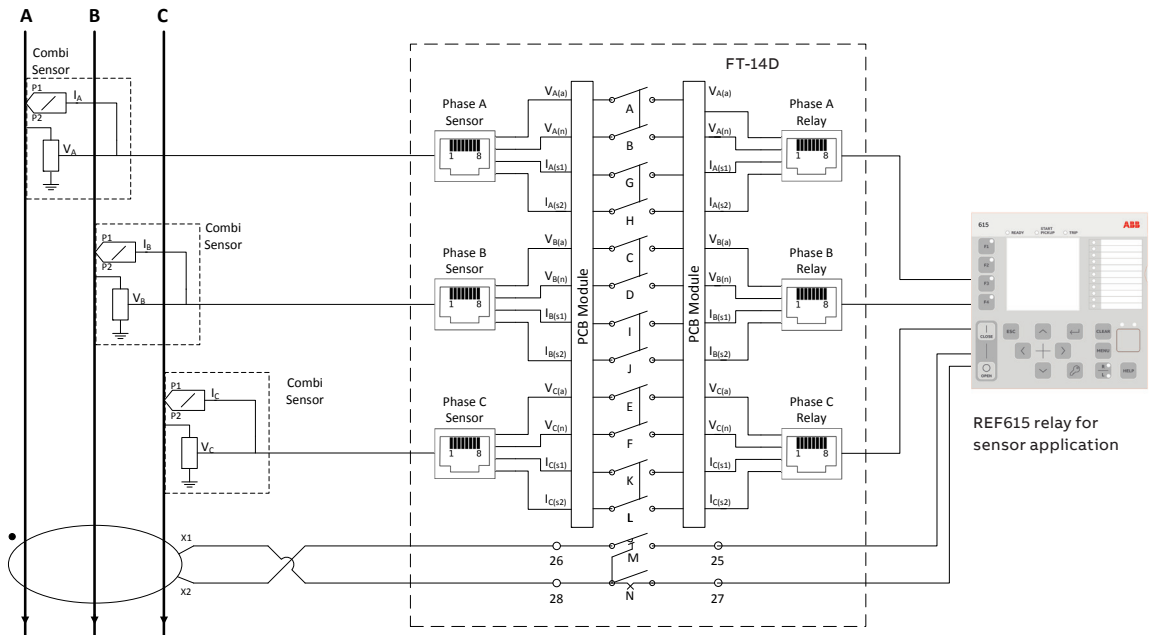

General concept FT-14D with combi sensors, external ground CT and REF615 sensor relay

50

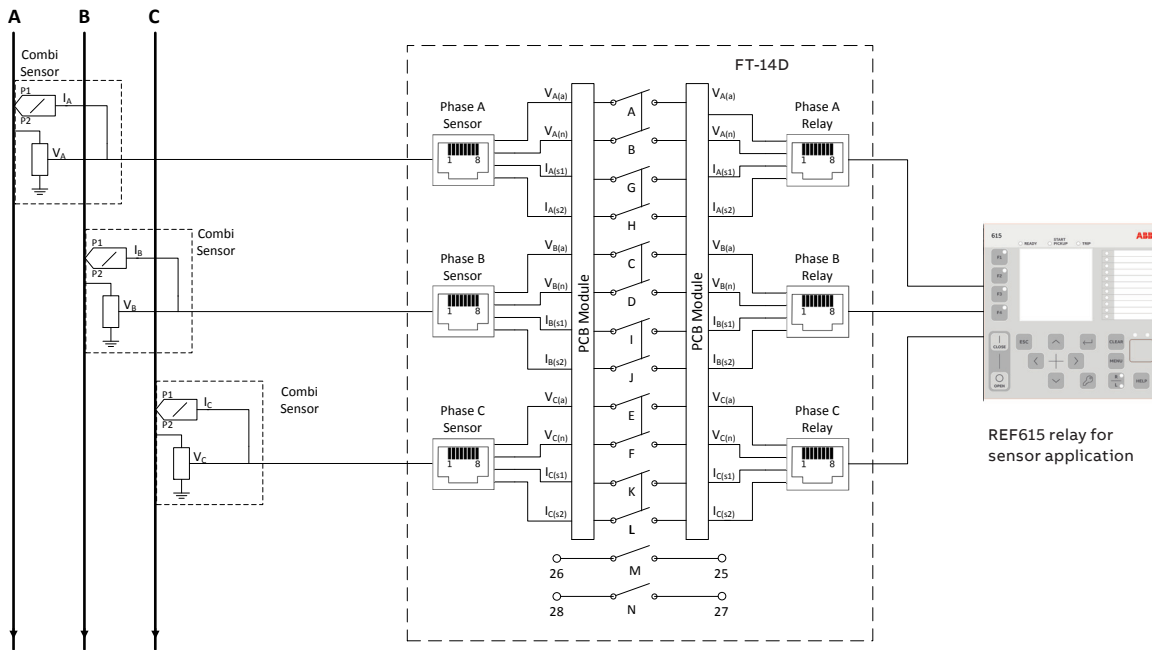

General concept FT-14D switch with combi sensors and REF615 sensor relay

51

52 FT-14D with current and voltage sensors and REF615 sensor relay

53 FT-14D switch with current and voltage sensors and REF615 sensor relay

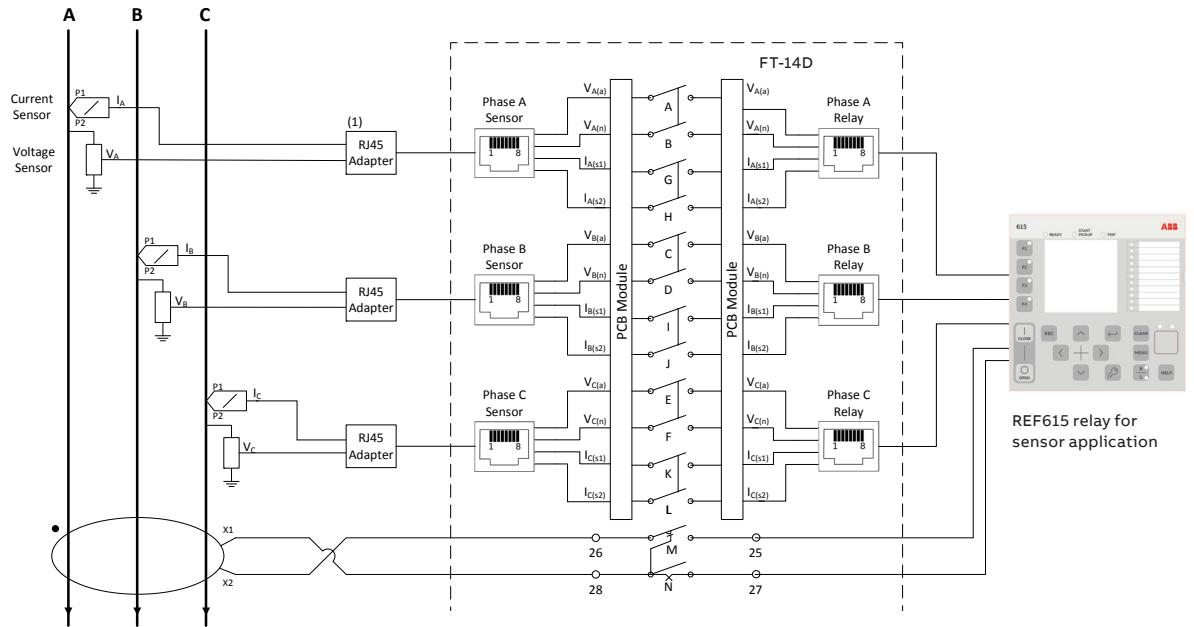

General concept FT-14D with separate current and voltage sensors, external ground CT and REF615 sensor relay

(1) If separate current and voltage sensors are used in application, use optional RJ45 adapter to merge the signals from current and voltage sensors. The RJ45 adapter is not required if only current sensor is used.

52

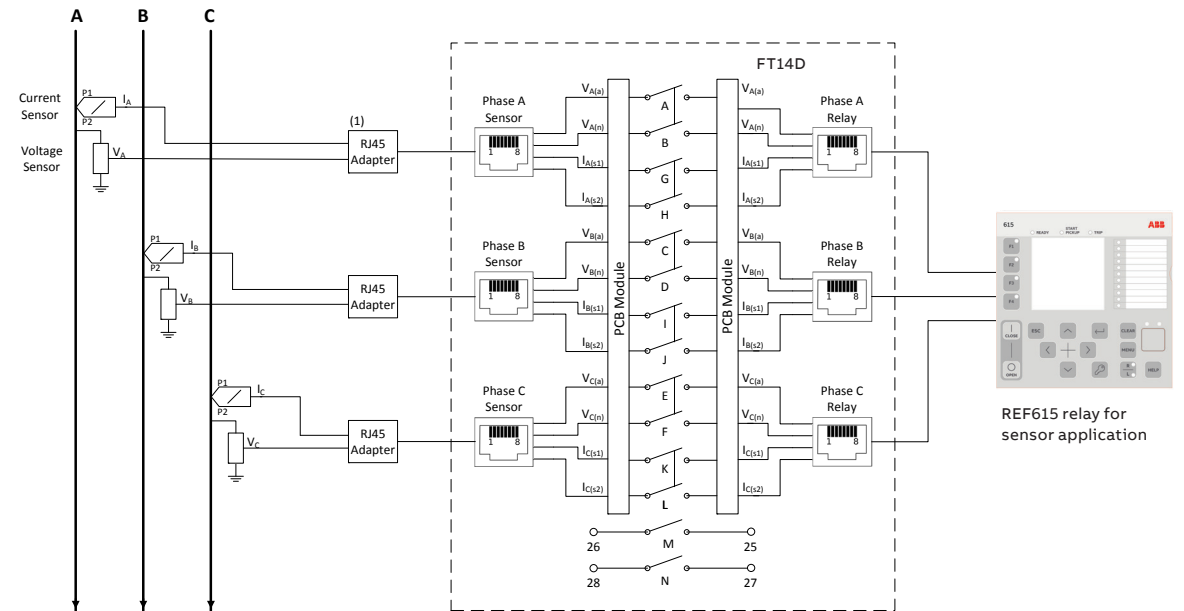

General concept FT-14D with current and voltage sensors and REF615 sensor relay

(1) If separate current and voltage sensors are used in application, use optional RJ45 adapter to merge the signals from current and voltage sensors. The RJ45 adapter is not required if only current sensor is used.

53

54 Relion REF615 FT switch connections, open delta with 3 phase and ground current connections

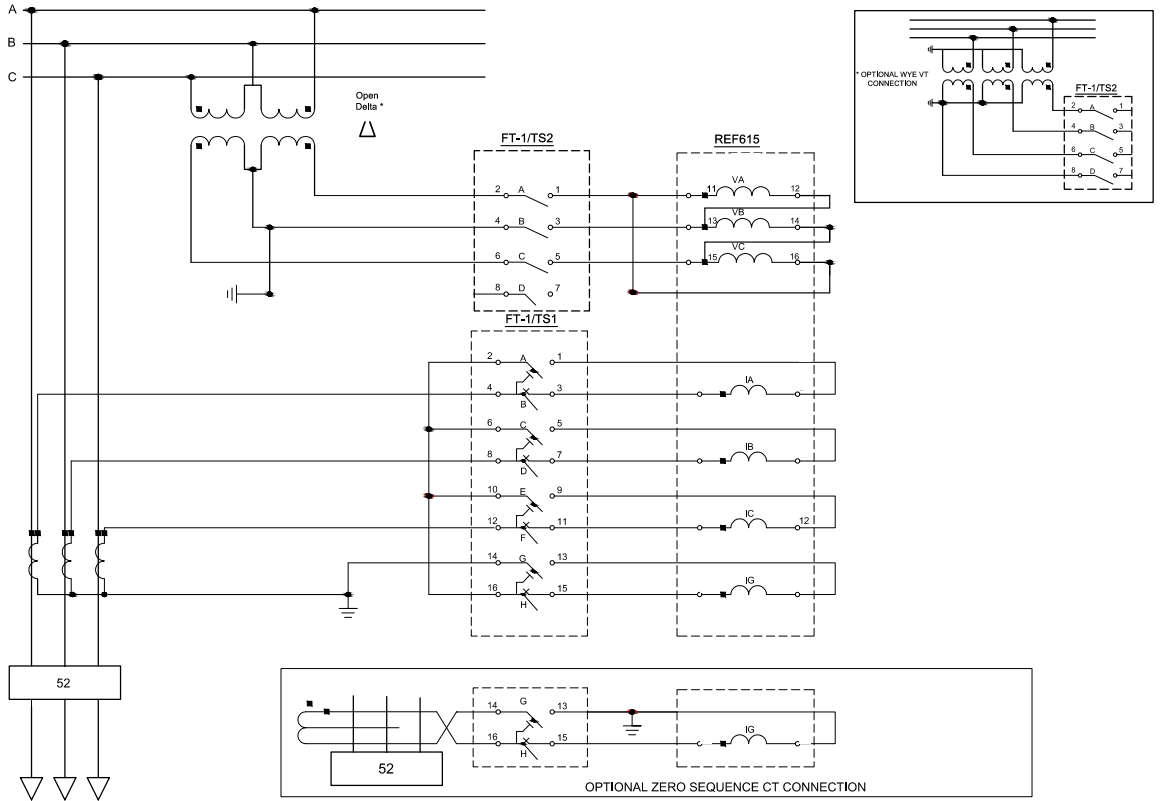
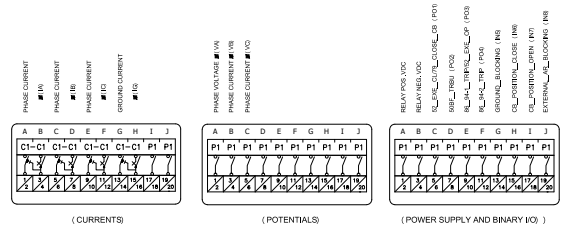
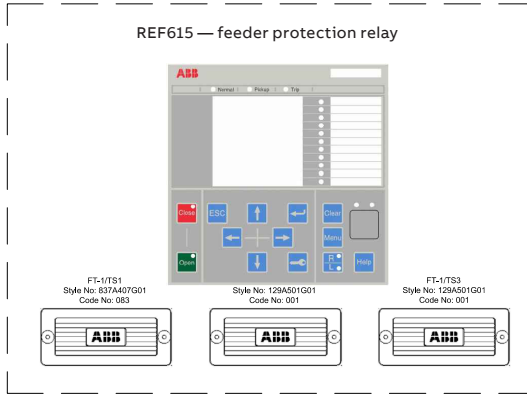

55 Relion REF615 FT switch connections, open delta and broken delta and broken delta with 3 phase and ground current connections

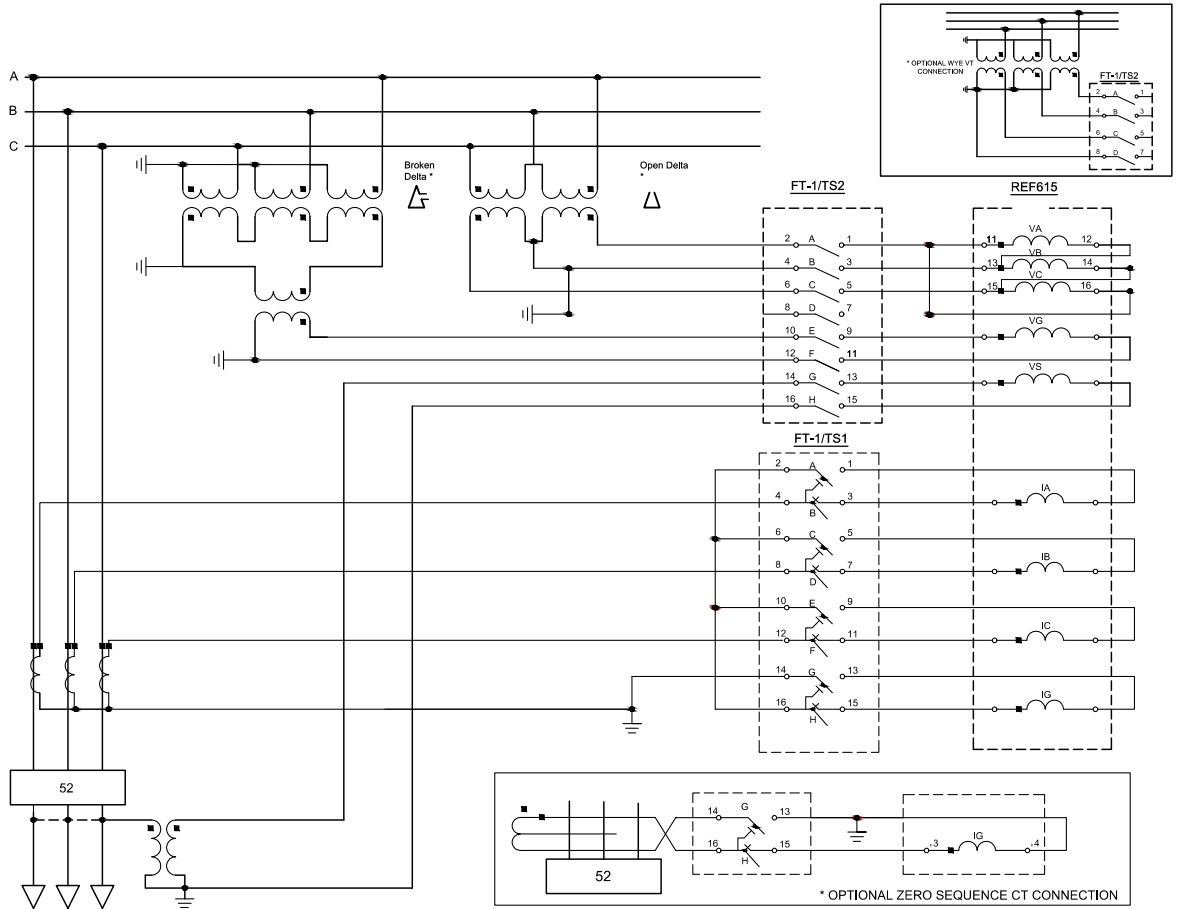
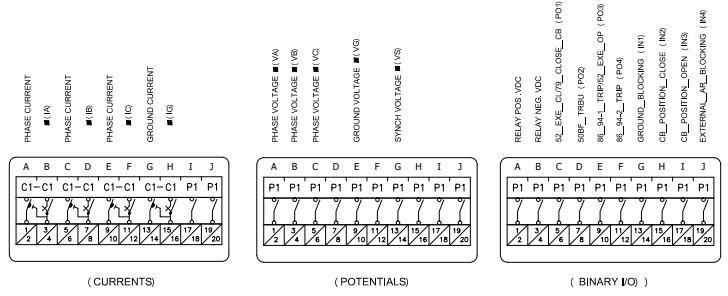
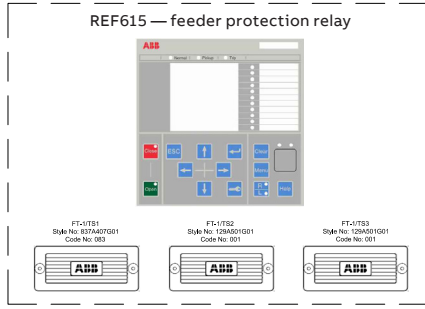

55  
Dimensions inches (mm)



—

**ABB Inc.**

3022 NC 43 North

Pinetops, NC 27864

Phone: +1 252 827 3212

**[abb.com/mediumvoltage](http://abb.com/mediumvoltage)**

—  
The information contained in this document is for general information purposes only. While ABB strives to keep the information up to date and correct, it makes no representations or warranties of any kind, express or implied, about the completeness, accuracy, reliability, suitability or availability with respect

to the information, products, services, or related graphics contained in the document for any purpose. Any reliance placed on such information is therefore strictly at your own risk. ABB reserves the right to discontinue any product or service at any time.

© Copyright 2025 ABB. All rights reserved.