

**NOTES:**

- WARNING:** This drawing does not illustrate completely the installation methods required for hazardous locations. Prior to any installation in a Classified Hazardous Location, verify installation methods by the Control Drawing referenced on the product's name tag and national and local codes.
- LED Indicators:**  
 Run LED – Blinking indicates on-board PIC running.  
 Activity LED – Blinking indicates buss activity.  
 Mode LED – 00 = Normal 01 = Reset
- LED Operation:**  
 Register 0.7.7 = 0 – Power Save Mode (LEDs off when MMI disconnected)  
 Register 0.7.7 = 1 – LEDs on all the time.
- Dip Switch factory default address is set at 0. If another COMBO IO/VC INTF TFIO is added, move that Dip Switch setting to 1. If more are added, use the next address in line for each.  
 Changing the address applies only to TFIOs of their own type, and not TFIOs of another type; those would also start at 0 and add new address of their own.  
 TIP: While 0 is recommended for the first one, any address can be used (But keep in mind the original config files in our software are built with this address and factory tests will look for it).

If a 3-Wire Sensor is used, wire Signal and GND as shown, and add Power from XFC/XRC VBATT Source

Arrival Sensor (2-Wire)

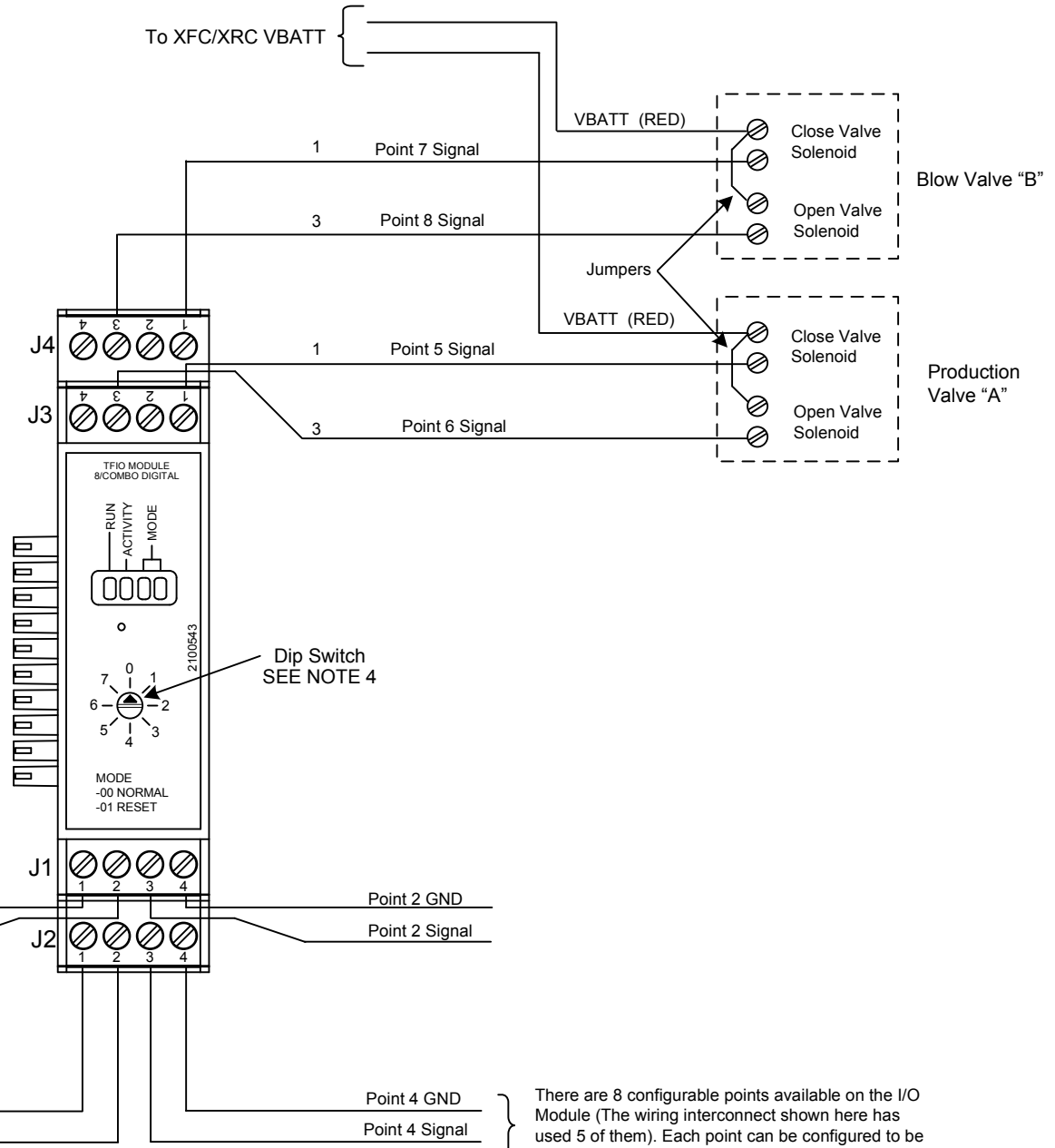

TFIO 8-Point Combo DI/DO/PI Module (2100543)

- Software for Plunger Lift Valve Control is included with the X-Series computers. Consult the User Manual to set-up and operate:

*XFC-Series or XRC-Series Flash  
 IEC Advanced  
 IEC w/Safety  
 Turner Curve*

REF: N/A

<b>ABB</b>	TOTALFLOW Products	ACTION	DOC TYPE	TITLE	DWG NO.	REV	SHEET
		L190150	UD	PLUNGER LIFT; DIRECT I/O OPTION	2102981	AA	1 OF 1