



UL Industrial Control Panels: Solutions Tailored for the IEC Market

A summary for UL and NEMA compliant control, protection, and switching devices



- For industrial control panel manufacturers supplying the North American market
- A summary of the information to help you understand the applicable standards
- Simplifies standard-compliant projecting and saves time

Successful business in the USA through sound knowledge of standards

Product compliance standards in the US market are much stricter. Electrical products exported for installation in the US may be subject to certification requirements, including compliance with various standards such as UL and NEMA. In this document, we will explain what UL and NEMA certification means, what to look out for, and how we can support you with our extensive expertise and a wide range of UL Listed or UL Recognized as well as NEMA-compliant low-voltage control panel components.

Content

4	1. Standards in North America and Canada overview
7	2. UL basics and the UL numbering system
9	3. UL File numbers and E-Files
10	4. Overview of the most important applicable standards
12	5. Relevant aspects of UL 508A
17	5.1 Selecting the right Short-circuit Current Ratings (SCCR) level and protection device
18	5.2 North American voltage supply networks and load types
18	5.3 Three-phase network configurations
19	5.4 Overcurrent protection and dimensioning of the main circuit
20	5.5 Circuit elements and switches of a control cabinet
22	6. Introduction to UL 489 and UL 1077
22	6.1 UL 489 and UL 1077
23	6.2 The difference - UL 489 and UL 1077
24	6.3 Structural comparison: UL 489 circuit protector and UL 1077 supplementary protector
26	7. UL 248 – Safety low-voltage fuses
27	8. UL 98 – Switch fuse
28	9. Combination motor controller components according to UL 60947-4-1 (formerly UL 508)
30	9.1 Type A
32	9.2 Type C
33	9.3 Type D
34	9.4 Type E
35	9.5 Type F
36	10. Softstarters in UL Control Panels
39	11. ABB Drives in UL Control Panels
40	12. NEMA Standard for Industrial Control Panels
45	13. UL Coordination Ratings or UL Component Ratings
46	14. Coordination with SOC
48	15. The Automation Panel
50	16. Quick search table for UL file
55	17. Components with UL CCN numbers

1. Standards in North America and Canada overview



North America United States

In the United States, voluntary standards are developed and published by various standard-setting organizations. For those who are not familiar with the scope of jurisdiction of these organizations, it can be extremely difficult to understand the interrelationships between the different standard-setting, testing, and regulatory bodies, to understand the standards applicable to a particular product, how to comply with the standards, and who is authorized to enforce them.

All US standards are promulgated on the federal and/or state level. documents.

The most widely adopted standard in the world is the National Electrical Code “NEC”, which is promulgated by consensus by the National Fire Protection Association. The NEC or NFPA 70 defines the minimum requirements for the safe installation of electrical wiring and equipment. The NEC has been adopted into law by all 50 U.S. states and most local municipalities. The NEC establishes requirements for products and equipment that are used in electrical installations and may require them to be listed (certified) to a product safety standard by an accredited nationally recognized testing laboratory (NRTL). Enforcement and compliance with the NEC are overseen by state and local authorities or Authority Having Jurisdiction (the “AHJ”).

What is the certification needed?

To determine which type of certification is required, it must first be determined to which category the product belongs. The categories are among others:

- - What component or device?
- - Is it a system or equipment?
- - Where is the location and manner in which the product is installed, who has jurisdiction and
- - Whose standards apply?

Certification by an independent institute or Nationally Recognized Testing Laboratory (“NRTL”) is mandatory for all electrical components and electrical equipment (assemblies of components). In the U.S., the Occupational Safety and Health Administration (“OSHA”) has established standards for the accreditation of NRTLs. Such labs include “Underwriters Laboratories” (UL), Intertek (ETL), TUV Rheinland or Sud (TUV), and CSA Group (CSA). A current listing of NRTLs can be found at www.osha.gov.

Systems and plants consisting of components do not require NRTL certification. However, all installations must be inspected and approved by the Authority Having Jurisdiction (AHJ) before commissioning. Generally, the AHJ is the local governmental agency charged with the inspection and approval of all installed electrical systems. The AHJ enforces the National Electrical Code (NEC).

Here are other important organizations for setting standards for low-voltage products and their applications.



ANSI: American National Standard Institute

ANSI is an important standard body in the U.S. and was founded in 1918. It publishes a large number of different, not exclusively electrical standards. ANSI only reviews and accredits standards written and proposed by the respective member organizations.



IEEE: The institute of electronic and electro-technical engineers

Founded in 1884, the IEEE’s mission is to promote the development of electrical engineering and its applications for the benefit of mankind. The wide-ranging standards are published by agreement between manufacturers (45%), end users (45%), and other interested parties (10%).



The “Technical Committee of the Power Quality Engineering Society” is part of the IEEE and publishes standards that are accredited by ANSI.



NEMA: National Electrical Manufacturer's Association

The association was formed in 1926 from a merger of two industrial associations and today represents the interests of American manufacturers of electrical equipment.



NETA: International Electrical Testing Association

NETA's task is to publish specifications for the certification companies and testing bodies, as well as to certify testing companies and promote the services of their members. The association also collects and disseminates valuable information for the electrical industry and educates them about maintenance tests and abandon specifications.

The organization can develop ANSI standards and define regulations for the safety and reliability of equipment.



NFPA: National Fire Protection Association

NFPA's mission is to reduce global fire hazards. They provide consensus codes and standards everywhere, research and train. The organization was founded in 1896 and has published 300 documents since then. The main ones are NFPA 70 and NFPA 70E. NFPA 70, also known as the National Electrical Code, deals with electrical wiring and equipment. NFPA70 (NEC) therefore concerns low-voltage products that require a high level of security such as IP protection, arc flash protection, and locking systems.

NFPA 70E specifies requirements for safe working practices.



UL: Underwriters Laboratories

UL was founded in 1894 with funding from fire insurance companies. Its mission is to analyze and assess the fire risks of electrical equipment.

UL's subsidiaries include UL Solutions and UL Standards & Engagement which have a global presence. Local contact points can be easily found via the following link: <http://ul.com/aboutul/locations/>

UL is an accredited standards developer in the US and Canada. It has developed over 1,500 Standards under its global public safety mission to build a safer, more sustainable world.

Design, manufacture, installation, and operation. To establish the compliance of a product with an applicable UL standard, all products are first tested in UL laboratories under the supervision of independent technicians. After the initial inspection, inspections are carried out regularly to ensure the same quality.

Important UL standards applicable to components used in control panels are covered in this brochure:

- UL 98: Fuses and Fuse less Switches
- UL 489: Circuit Breakers
- UL 508: Electrical Switchgear
- UL 60947-4-1: Motor Starter

—

While NEMA, UL, IEEE, and NFPA each have their areas of focus, they often work together to develop and enforce electrical standards. This includes discussing with each other, exchanging information, and avoiding overlaps and contradictions.

Canada

Each final installation must comply with specific regulations defined by several state associations. The principle of Canadian safety requirements and standards is similar to that of the United States.

The most important association for electrical equipment is the CSA:



CSA: Canadian Standard Association

The CSA is a non-profit organization that develops standards for many areas of industry and technology. CSA's mission is to meet the needs of Canadian society in terms of safety, quality of life, trade, and environmental protection.

CSA is the certification body for Canadian products and their standards are compliant with UL and others (IEC).

2. UL basics and the UL numbering system

Product compliance standards in the US Market are much stricter than in Europe. Electrical products exported for installation in the US may be subject to certification requirements including compliance with various standards such as UL. In this document, we will explain what UL certification means, what to look out for, and how we can support you with our extensive expertise and a

wide range of UL Listed or UL Recognized low-voltage control panel components.

The terms “UL Listed” and “UL Recognized” refer to different classifications assigned to products by Underwriters Laboratories (UL) and have different meanings:

UL Listed	UL Recognized
<ul style="list-style-type: none"> • A product has been extensively tested by UL to ensure that it meets certain safety standards. • The products are usually end products or systems intended for installation or use as a complete unit. • The entire product, including its components and materials, has been tested for safety and meets the applicable standards. • It reassures consumers and authorities that the product is safe for its intended use and has passed rigorous testing. 	<ul style="list-style-type: none"> • A component or material has been evaluated by UL individually, but not necessarily as part of a complete product. • These components are usually building blocks used in the construction of larger systems or products. • This mark is often found on parts such as electrical insulation materials, wiring, or electronic components that are incorporated into larger devices. • The UL mark means that the individual component or material meets certain safety requirements, but it does not necessarily mean that the final product meets these standards.

Both UL Listed and UL Recognized indicate compliance with UL safety standards, the main difference is the scope of the rating. UL Listed applies to complete products, while UL Recognized refers to individual components or materials that can be used in the construction of larger systems.

UL Category Control Numbers (CCN) are a marking used by UL to identify products and components that have been tested and certified by them. The CCN number is an important part of the UL certification process and helps to verify a product’s compliance with safety standards. The first system is the assignment of a number to the product. UL assigns products and product cate-









gories an alphanumeric code called CCN (e.g. “Category Control Number”). For instance, the CCN for electric fans is GPWV. A suffix denotes the level of compliance for the product in the applicable jurisdiction:

	United States	Canada
Listed	(no suffix)	XXXX7
Recognized	XXXX2	XXXX8

In the instance of the electric fan, the suffixes indicate the electric fan is UL Recognized in the US and ULc Listed in Canada:

	United States	Canada
Listed	GPWV	GPWV7
Recognized	GPWV2	GPWV8

When one of the following markings appears on a product it denotes the UL standard with which the product complies:

	The product is certified according to UL (Listed) and complies with U.S. Standards	
	The product is certified according to UL (Listed) and complies with Canadian Standards	
	The product is certified according to UL (Listed) and complies with Canadian and U.S. standards	
	The product is certified according to UL (Listed) and complies with European standards	
	The product is UL (Listed) certified and complies with European, Canadian, and U.S. standards	
	The product is UL (Recognized) certified and complies with U.S. standards	
	The product is UL (Recognized) certified and conforms to Canadian standards	The CoA (Conditions of Acceptability) are required for the use of these products.
	Product is UL (Recognized) certified and complies with Canadian and U.S. standards	

3. UL File numbers and E-Files

In the second numbering system, UL assigns a marking, known as an E-File or UL File Number, to each manufacturer's product or product group that has been submitted for testing. This marking serves as an identification number by which the product is included in the UL database. A typical

E-File or UL File Number consists of the letter E followed by a six-digit number. An example is the number E345003 for an ABB motor controller certified to UL 508:

The screenshot displays the UL Product iQ interface for the document NKJH.E345003 - Combination Motor Controllers. The interface includes a navigation bar with 'SEARCH', 'MY SEARCHES', 'MY TAGS', and 'THOMAS'. The main content area is divided into 'Document' and 'Company Information' tabs. A yellow banner at the top of the document section reads: 'Note: We are enhancing our systems and you may notice duplicate entries/missing/outdated data. During this interim period, please contact our Customer Service at <https://www.ul.com/about/locations>.' Below this, the title 'Combination Motor Controllers' is centered. The 'COMPANY' section lists 'ABB Stotz-Kontakt GmbH' with its address in Heidelberg, Germany. The 'RESOURCES' sidebar on the left contains links for 'UL Confirmation Letter', 'Columbia Market Access Certification', 'View Products in this Listing', and 'Guide Info (NKJH)'. The main content area provides detailed information about the product, including model numbers and certification details. The 'Last Updated' date is shown as 2023-05-23.

The UL Product iQ database (formerly the Online Certifications Directory) provides specific information about the manufacturer, product, and applicable UL standard related to the specific UL File Number. The corresponding data sheets (also known as Yellow Cards) for the E-File Number are also available here. A free user account is needed to access this information.

It is important to note that the existence of UL File is not proof that the product has been certified by UL. Only the corresponding UL certificate can provide this assurance. Therefore, while the label may indicate certification to the end users, consumers and inspectors; actual proof of certification can be found by accessing the test data sheets in the iQ database.

The E-File Number appears on the product's nameplate along with the Category Code Number (CCN) or can be found on the UL label itself.

4. Overview of the most important applicable standards

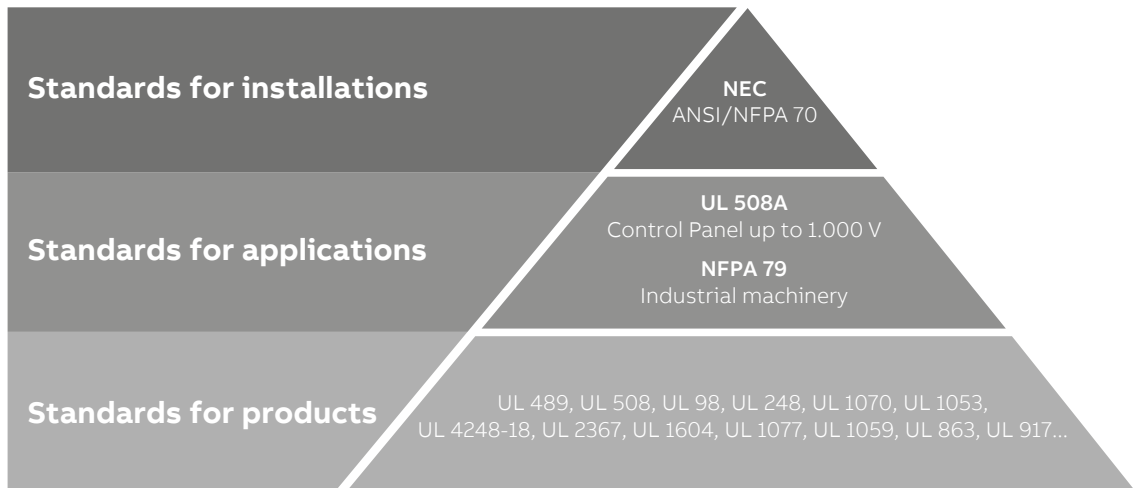

US-Standard			approximate IEC standard
General installation instructions			
NFPA 70	National Electrical Code	The National Electrical Code (NEC), or NFPA 70, is a standard for the safe installation of electrical wiring and equipment in the United States. It is part of the National Fire Codes series, which is published every three years by the National Fire Protection Association (NFPA). Despite using the term "national", it is not a federal regulation. It is usually adopted by states and local jurisdictions to standardize the enforcement of electronic practices. The NEC defines all requirements for the safe installation of electrical cables to be able to design a draft standard. It sets standards for the installation of electrical wiring inside public and private buildings, including mobile homes and recreational vehicles, as well as floating buildings. He also prepares the standards for industrial distributions and other structures that can be connected to the electrical grid. Electrical wiring in ships, trains, airplanes, or other vehicles, other than mobile homes and recreational vehicles, is not to be designed according to NEC.	IEC 60364-1
Application standards			
NFPA 79	Electrical Standard for Industrial Machinery	NFPA 79 is a section of the NEC that defines protective measures for industrial machinery to protect operators, equipment, and facilities and protect work-in-progress from fire and electrical hazards. The requirements apply to electrical/electronic devices, apparatus, or systems as part of industrial machines from the electrical feed with a nominal voltage of up to 1,000 V. NFPA 79 now also contains important safety aspects.	IEC 60204-1
UL 508A	Industrial Control Panels	The requirements of this standard apply to industrial control cabinets intended for general industrial use up to a rated voltage of 1,000 V and intended for installation in ordinary areas by the National Electrical Code ANSI/NFPA 70 with a maximum ambient temperature of 40 °C (104 °F).	IEC 61439-1
Product standards			

UL 98	Enclosed and Dead-Front Switches	Enclosed and Dead-Front Switches are closed and voltage-free switches. These requirements of this standard apply to individual open switches up to 4,000 A and 600 V, in which all current-carrying parts are enclosed and can be manually switched by external handles. UL (* is based on the national installation regulations Appendix A, Ref. No.1. If fuses are included, these switches can also perform a protective function.	IEC 60947-3
UL 248	Low-Voltage Fuse	The requirements of this standard apply to low-voltage fuses with a nominal voltage of up to 1,000 V, AC and/or DC, with a breaking current of up to 300 kA (Mexico 200 kA) and specified for use with fuse holder UL 512. These safeguards are intended to be "Canadian Electrical Code" Part 1 (CEC) and the National Electrical Code (NFPA 70). The standard is divided into different sections, where the fuses for different applications are considered.	
UL 489	Molded-Case Circuit Breakers, Molded-Case Switches and Circuit Breaker Enclosures	The requirements of this standard apply to compact switches, circuit breakers, residual current protection devices, circuit breakers with fuse, high-fault detectors, and high-fault modules with rated currents up to 6,000 A and rated voltages up to 1,000 V AC and 1,500 V DC. UL 489 contains additional regulations for civil and naval applications.	IEC 60947-2
UL 508	Industrial Control Equipment	The requirements of this standard apply to industrial control units and equipment accessories for starting, stopping, regulating, controlling, and protecting electric motors. These requirements also apply to industrial control units or systems that store process information and implement control functions with a motor at the output. UL 508 also applies to devices up to 1,500 V. Unless otherwise specified, the equipment covered by UL 508 shall be operated at an ambient temperature between 0-40 °C (32-104 °F).	IEC 60947-2, IEC 60947-4-1
UL 1053	Ground-Fault Sensing and Relaying Equipment	The requirements of this standard apply to devices for protection against fault currents, trapping devices, and/or combinations thereof for use in ordinary areas. In the U.S. all such equipment is known as "Ground Fault-Sensing and Relaying Equipment."	
UL 1077	Supplementary Protectors for Use in Electrical Equipment	The requirements of this standard apply to additional protective devices to protect against overcurrent, over-, and undercurrent voltage either in an appliance or other electrical equipment where overcurrent protection is present or not required. This equipment can be used as a component of a final product or as supplementary protective devices. They cannot be used as the sole protection of distribution circuits, but only as a supplement or for control circuits.	IEC 60947-2, IEC 60934
UL 1604	Electrical Equipment for Use in Class I and II, Division 2, and Class III Hazardous (Classified) Locations	The requirements of this standard apply to components and electrical equipment that are installed in hazardous areas	
UL 2367	Solid State Overcurrent Protectors	The requirements of this standard apply to semiconductor overcurrent protection devices which are semiconductor switches designed to minimize the maximum output current when the output load exceeds the current limit or when there is a load-side short-circuit. Semiconductor overcurrent protection devices can be used as a supplementary protective measure on the load side of an isolated transformer, power supply, or battery.	
UL 4248-1, UL 4248-4, UL 4248-18	Fuse Holders - Part 1: General Requirements Fuse Holders - Part 4: Class CC Fuse Holders - Part 18: Photovoltaic	The requirements of these standards apply to fuse holders for industrial applications. Part 1 addresses general requirements and principles. Part 4 is specific to Class CC safety holders (NMX-J-009/248/4-200-ANCE, CSA C22.2 No.248.4, UL 248-4). Part 18 applies to fuse holders for photovoltaic systems.	

Global harmonization efforts

As globalization continues, it is becoming increasingly important to understand the rules and regulations of multiple world regions. Underwriters Laboratories (UL), the Canadian Standards

Association (CSA), and the International Electrotechnical Commission (IEC) are working together to combine best practices and produce harmonized global standards.

5. Relevant aspects of UL 508A



NOTE: This section does not supplant or eliminate the user's responsibility for owning, knowing, and following the UL 508A Industrial Control Panel Standard. ABB is not responsible for factual inaccuracies or damages that occur as a result of them. User use cases may differ from those explained in the following sections. Where discrepancies arise, the user must follow the 508A standard and all applicable codes.

The following section briefly highlights various sections of UL 508A that apply to Industrial Control Panels and the components which may be installed in them. For a complete understanding of the standards, reference to UL 508A in its entirety is necessary.

Main disconnect

(UL 508A, Paragraph 30)

Proper control cabinet design requires adherence to the nominal current values which are used to select the appropriate circuit breakers, main fuses, and access lines. According to UL 508A, circuit breakers must be used in one of the following two categories:

- “Molded-Case Circuit Breaker” (DIVQ),
- “Molded-Case switch” (WJAZ), “Switch Unit” (WHTY).

By NFPA 79 (electrical standard for industrial machinery) and specifically by paragraph 66.6.3 of UL 508A, the circuit breaker shall:

- Be easily accessible when the cabinet doors are open or closed.
- Be installed in such a way that its operation is not hindered by the open door.
- Be operational, regardless of the door position and without the use of accessories.
- Be able to be locked in the off position regardless of the door position, making it impossible to switch on.

Main Circuit Breaker

(UL 508A, Section 32.2)

To ensure compliance with UL 508A, the protection for individual branches in a control panel must use a Molded-Case Circuit Breaker (DIVQ) or a Branch Circuit Fuse certified to UL 248. The main protection for the entire panel can be part of the panel itself or come from a switchboard or panelboard upstream. The way these protection systems are built must follow the guidelines given in either paragraph 31.1, which covers the “General Requirements for Branch Circuit Protection,” or paragraph 31.4.1, which specifies the requirements for “Group Protection” (you can find more details in paragraph 66.7.4).

- The highest current value of the protection device in the control cabinet
- 125% of all heating loads
- 125% of the largest engine load
- The full-load currents of all other motors and other loads that can be operated at the same time

Contactors and Overload Components

(UL 508A, Paragraph 31)

Designing a control cabinet requires meticulous attention to its various components, including contactors and overload devices. ccc, helping to ensure the reliability and safety of the electrical system. To be compliant with UL 508A paragraph 31, only certain types of contactors and overload components may be integrated into control cabinets.

The following categories of contactors comply with UL 508A:

“Definite Purpose Contactors” (NRNT)
“Across-the-Line Contactor” (NTRT)
“Magnetic Contactor” (NISD)

The following categories of overload components comply with UL 508A:

“Thermal Overload Relay” (NRAQ)
“Overload Relay” (NROI)
“Motor Protective Switch” (NMFT)

NOTE: Selecting the appropriate overload components based on the specific application and operational requirements is critical.

By NFPA 79, and Paragraph 66.6.3 of UL 508A, the following conditions must be met when installing contactors and overload components into a control cabinet:

- **Easily accessible:** Contactors and overload components should be easily accessible whether the cabinet doors are open or closed. This facilitates maintenance, inspection, and troubleshooting procedures.
- **Unhindered operation:** The installation of contactors and overload components should not hinder their operation when the cabinet doors are open. This ensures efficient functionality and quick response in case of electrical faults.
- **Operational independence:** Contactors must remain operational regardless of the door position, ensuring seamless performance during routine checks or emergencies. The use of accessories should not be a prerequisite for their basic operation.
- **Coordination with circuit protection devices:** Contactors and overload components must be coordinated with circuit protection devices to guarantee optimal performance. This includes proper sizing and selection to prevent overheating and damage to the connected machinery.
- **Documentation and compliance:** Detailed documentation, including electrical schematics and component specifications, should be maintained in compliance with UL 508A standards. This documentation aids in system understanding, troubleshooting, and future modifications.

Transformer/Power Supply Protection

(UL 508A, paragraph?)

Transformers to be utilized in a control panel must meet the UL certification requirements for the XPTQ and XPTQ2 categories. The following devices may be installed as protection for transformers and power supplies:

- Case Circuit Breakers (DIVQ)
- Fuse holders (IZLT): mostly class CC fuses

Note: A Motor Starter Protector (NKJH) must not be installed as protection for transformers and power supplies.

The control transformer protection dimension requirements:

- Primary side: the current rating will not be higher than 500% (less than 2 A) and 250% (equal to or greater than 2 A) (UL 508A, Table 42.2)
- Secondary side: the current rating will not be higher than 167% (less than 9 A) and 125% (equal to or greater than 9 A) (UL 508A, Table 42.2)

The power transformer protection dimension requirements:

- Primary side: the current rating will not be higher than 300% (less than 2 A) and 250% (equal to or greater than 2 A) (UL 508A, Table 35.2)
- Secondary side: the current rating will not be higher than 167% (less than 9 A) and 125% (equal to or greater than 9 A) (UL 508A, Table 35.2)

Motor Branch Protection

(UL 508A, Paragraph 31.1)

A self-protecting combination motor controller (NKJH) or a manual self-protected combination motor controller needs to meet the standards set by “Standard for Industrial Control Equipment” UL 60947-2 and/or UL 508. Additionally, when used with the right accessories, it should work seamlessly with the “Self-protected combination motor controller”.

Alternatively, each motor circuit is protected against short-circuits with overcurrent protection, with a thermal barrier according to category NKCR or NKCR2 and a rated current of max. 115% against short.

If a contactor (certified according to category NLDX) is used, it must be dimensioned to the short-circuit current value of the circuit. Coordination tables for motor protection:

<http://applications.it.abb.com/soc>

Control Circuits (LVLE)

(UL 508A, Paragraph 43)

Control circuits must not exceed 30 V AC or 60 V DC and their protective devices on the secondary side must comply with the requirements of Table 43.1.

Cable

(UL 508A, different paragraphs)

UL 508A sets forth specific cable dimensions and color requirements. Contactors must have a minimum cross-section of 14 AWG (American Wire Gauge) and control contactors of 18 AWG (signal cables up to 30 AWG). The cross-section and color of the cables must be adapted to the regulations and power cables must be dimensioned to 125% of the nominal current. According to Table 15.1 of

UL 508A, the earthing conductors must be dimensioned depending on the main protection. The accepted categories are AVLV2 (Appliance Wiring Material, minimum 90°C), ZKHZ (Machine tool wiring), ZKST (Thermoset-Insulated wire), ZLRG (Thermoplastic-Insulated Wire), ZMAY (Welding Cable, minimum 90°C). The following table lists the color assignments.

Phase	Black
Neutral	Grey
AC Control conductor	Red (phase) + white or red/white (neutral)
DC Control conductor	Blue (phase) + white/blue (neutral)
Circuits alimented even with "opened doors" conditions	Orange or yellow (phase) + orange/white or yellow/white (neutral)
Grounding conductor	Yellow/green or green

Short-circuit Current Rating (SCCR)

(UL 509A, Paragraph 31, 66, 67, 68)

To mark a control cabinet with an SCCR of 65 kA, all circuits, their components, and the main switch must be equipped for a short-circuit current of 65 kA. If no SCCR value is specified for individual components, the values from Table SB4.1 and SB4.2 can be used.

Determining the correct Short-circuit Current Rating (SCCR) for the control panel's label is a challenging but crucial step in creating safe and reliable products. The guidelines for finding the SCCR value are detailed in Supplement SB to UL 508A. You can comply with Supplement SB requirements by:

1. Hiring an NRTL to test the design for a short-circuit current rating.
2. Following the steps in Supplement SB and documenting the SCCR determination.

Refer to Supplement SB for the detailed process. In summary, the steps include:

1. **Individual SCCR ratings:** Use Table SB4.2 to establish the individual SCCR ratings of each power component.
2. **Modification of short-circuit current:** Adjust the available short-circuit current within a circuit section due to current-limiting components, following Table SB4.3.
3. **Determination of overall panel SCCR:** Establish the overall panel short-circuit current rating using Table SB4.4.

If components lacking SCCR labels are used without a determination from table SB, default values in Table SB4.1 will apply. This often results in low SCCR values, limiting the control panel's application capabilities. Using listed components or combinations (e.g., combination motor controllers) with proven SCCR ratings helps identify crucial information for safety and certainty in the final assembly.

Field wiring

A field wiring connection is deemed secure and suitable when it is established by the relevant regulations. The responsibility for reviewing these requirements does not fall on the end user; however, it is crucial to adhere to these regulations when creating connections between different systems.

This includes paying attention to specific details such as the proper tightening torque for screw terminals. The requirements for cabling are established by NEC and UL. These standards establish guidelines and best practices for the safe installation and use of electrical systems and wiring.

Factory wiring

To be able to check the safety, a further evaluation is required. For this reason, the system must be created under the supervision of the manufacturer and UL engineer. A “factory wiring only” connection must always be described in the terms of use of the UL report. “Internal wiring” is also used as a synonym for “factory wiring”.

To ensure safety and facilitate assessment, an additional evaluation is necessary for factory wiring specifications. Therefore, the system must be established under the guidance of both the manufacturer and a UL engineer. Any connection labeled as “factory wiring only” must always be detailed in the terms of use specified in the UL report. The term “internal wiring” is synonymous with “factory wiring.” This emphasizes that the wiring carried out within the manufacturing facility is integral to the overall safety and functionality of the system.

5.1 Selecting the right Short-circuit Current Ratings (SCCR) level and protection device for your UL application

Choosing the right Short-circuit Current Rating (SCCR) level and protection device is critical for safety and compliance in electrical system design. Consider the following key steps:

- System analysis: Understand your system’s requirements and potential short-circuit currents.
- Component ratings: Evaluate SCCR for individual components, ensuring alignment with application needs.
- Coordination: Choose devices with compatible SCCR levels for effective fault isolation.
- Application specifics: Be aware of any application-specific SCCR requirements.

With so many different applications and ratings for protective devices, it can sometimes be difficult to find the right SCCR value. Below you will find some general advice to help you make the right choice. In addition, you will find an “SCCR reference” next to each application diagram in the previous section. This reference refers to the column heading of a UL/CSA table for the maximum short-circuit current. These tables can be found in our main catalogs for the respective protective device, which you can access in the Download Center (<https://library.abb.com>) All Categories > Products > Low Voltage Products and Systems > Control Products.

UL/CSA Maximum short-circuit current ratings – MS165

Type	Manual motor controllers						Manual self-protected combination motor controllers (Type E)			
	Branch circuit protection, max. size per NEC/CEC (1)		For motor disconnect		For group installations		For tap conductor protection in group installations			
	Fuses	Circuit breaker	480 V	600 V	480 V	600 V	480 Y/277 V	600 Y/347 V	480 Y/277 V	600 Y/347 V
	A	A	kA	kA	kA	kA	kA	kA	kA	kA

Screenshot from the catalog of the UL/CSA maximum short-circuit current rating table.

For manual motor starters, there are several factors to determining the appropriate SCCR level:

- Where the secondary winding style of the upstream facility transformer is wye, or 347 V AC and below for delta networks, manual motor starters will be within the category of combination motor controllers:
 - manual control, select from the “Type E” SCCR
 - remote control, select “Type F”
 - ensure that any minimum component size requirements are respected.

In delta systems with voltages above 347 V AC, it is permissible to install an upstream fuse block and fuses. The manual motor starter, for example, can function as a primary feeder disconnect if it is labeled “Suitable as a motor disconnect” and is located on the load side of the feeder protection device. It is important to be guided by the short-circuit current rating (SCCR) for the “Motor Disconnect”. These SCCR values apply regardless of whether the upstream branch circuit protective device (BCPD) contains fuses or a circuit breaker unless otherwise specified.

For panels intended to manage multiple branch circuits, employing a group installation approach can be an efficient solution. In many industrial control panels, the power is supplied by a circuit breaker or a set of fuses, the size of which can be determined based on the specifications for group installation. In the United States, when utilizing manual motor starters within group installations for manual control, it is essential to refer to the Short-Circuit Current Rating (SCCR) for “Tap Conductor Protection.” In Canada or the U.S. when combining AF contactors for remote control, the appropriate SCCR should be selected from the “Group Installation” category. To streamline group installations, a 3-phase accessory busbar is available, providing a compact and efficient solution.

To accurately determine short circuit ratings in industrial control panels, refer to the document titled “4 Steps to Calculate Short Circuit Ratings in Industrial Control Panels.” This guide provides a systematic approach to ensure safety and compliance.

link: *has to be found*

5.2 North American voltage supply networks and load types

Electrical networks in North America supply power to residential, commercial, and industrial structures. Depending on the amount of power required for a given installation, various voltage configurations can be utilized.

North American commercial installations are typically supplied using either 120/240 V AC split (dual) or 208 Y/120 V AC, 3-phase wye networks. Industrial installations within the U.S. commonly use 480 Y/277 V AC, 3-phase wye networks. For Canada, the network voltages are increased to 600 Y/347 V AC. However, 3-phase delta networks, which do not offer a line-to-neutral voltage, are also common, most often supplying either 240, 480, or 600 V AC.



Application	Network configuration (excluding ground wire)	Nominal supply voltage (line-to-line)	Nominal supply voltage (line-to-neutral)
Commercial	2-phase, 3-wire	240 V AC 2-phase (split/dual)	120 V AC 1-phase
	3-phase, 4-wire (wye)	208 V AC 3-phase	120 V AC 1-phase
Industrial and large commercial in the United States	3-phase, 3-wire (delta)	240 V AC 3-phase	--
	3-phase, 4-wire (wye)	480 V AC 3-phase	277 V AC 1-phase
	3-phase, 3-wire (delta)	480 V AC 3-phase	--
Industrial and large commercial in Canada	3-phase, 4-wire (wye)	600 V AC 3-phase	347 V AC 1-phase
	3-phase, 3-wire (delta)	600 V AC 3-phase	--

5.3 Three-phase network configurations

North American 3-phase supply networks differ based on the secondary winding of the upstream transformer. The two most common secondary winding styles are (1) wye, which includes three power legs and a neutral, and (2) delta, which includes only three power legs without a neutral

connection. These networks can be either grounded or ungrounded.

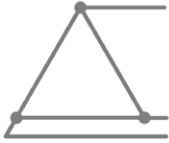
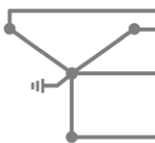
Solidly grounded wye and ungrounded delta networks are most common in North America.

Most common			
			
Delta (ungrounded)	Wye	Delta (corner-grounded)	Delta (center-grounded)
Solidly grounded networks			

Straight vs. slash voltage ratings

Short-circuit protective devices with straight voltage ratings (e.g. 480 V AC) can be applied in any circuit, grounded or ungrounded, where the line-to-line voltage does not exceed the maximum rating specified.

Short-circuit protective devices with slash voltage ratings (e.g. 480 Y/277 V AC) can be applied only in solidly grounded networks where the voltage from the line to the ground does not exceed

the lower of the two ratings (e.g. 277 V AC), and the voltage from line-to-line does not exceed the higher of the two ratings (e.g. 480 V AC). The lower rating represents the device's interrupting capability per pole.

Depending on how they are applied, manual motor starters carry either straight (Δ) or slash (/) voltage ratings.

Rating type	Maximum voltage
Manual motor controller	600 Δ
Manual motor controller, suitable as motor disconnect	600 Δ
Manual motor controller, suitable for use in group installations	600 Δ
Manual motor controller, suitable for tap conductor protection in group installations ¹⁾	600 Y/347 V
Manual self-protected combination motor controller (type E for UL)	600 Y/347 V
Combination motor controller (type F for UL)	600 Y/347 V
Protection of ABB microdrives	480 Y/277 V

5.4 Overcurrent protection and dimensioning of the main circuit

According to the regulations of NEC, UL 508A, and NFPA 79, the dimensions of switch cabinets and the electrical equipment of machines and systems must be appropriate and provide overcurrent protection. The devices used must be certified for the specific area of application. In addition, UL uses product categories to identify devices and their area of application (see also section on categorization with the Category Code Number (CCN)).

Overcurrent

Overcurrent is a broad term covering three types of currents: overload current, short-circuit current, and ground fault current. Overcurrent protection involves using a device that breaks the circuit when the normal current is exceeded. The chosen current capacity ensures the circuit disconnects when there's too much current due to overload, short-circuits, or ground faults, safeguarding the conductors and the system.

5.5 Circuit elements and switches of a control cabinet

Electrical distribution within a facility requires the coordination of many circuits to loads. Beyond the point of the service entrance, all circuits leading away are considered feeders or feeder taps, until just ahead of a load. The circuit between the load-side terminals of the final overcurrent protective device and the load itself is called the branch circuit. This also means that the branch circuit protective device is part of the feeder circuit, not the branch. The figure below shows an example of this.

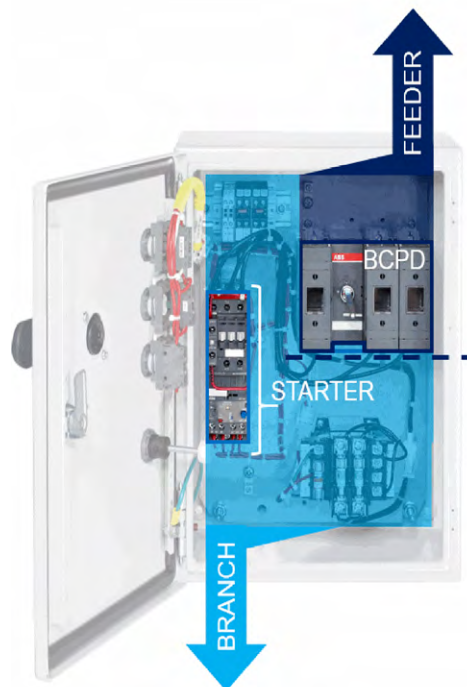

The main circuit according to UL 508A and the short-circuit strength of the control cabinet's main circuit requires an Industrial Control Panel to be marked with an SCCR (Short-circuit Current Rating), which is roughly equivalent to the I_{cw} value of the switchgear in IEC. NEC 2011 Art. 409 outlines the provisions for short-circuit strength markings on switchgear (referring to UL 508A, SB4).

When it comes to short-circuit strength, not only is the short-circuit switching capacity, e.g., of the main switch, relevant but also the short-circuit strength of each device in the main circuit. Components relevant to SCCR include circuit breakers, contactors, overload relays, semiconductor switching devices, terminals, busbars, the input side of control transformers, and frequency inverters, but not internal control cabinet wiring. The component with the smallest value determines the SCCR of the entire cabinet. No transformer with a higher short-circuit current may be connected to the control cabinet.

Note: Only certain devices are approved as main switches, e.g., Circuit Breaker according to UL 489, and UL 98 listed as fusible or non-fusible disconnect switches and safety switches.

Definitions feeder circuit (distribution circuit): Starting from the load of all products above the first "overcurrent" protective device of the branch (branch circuit protective device).

Definitions branch circuit: All products start from the load up to the first "overcurrent" protective device of the branch (branch circuit protective device).

The protection of other loads like non-motor loads must be protected as specified in the manufacturer's UL report.

The term “branch circuit’ applies regardless of the type of load. Common load types for industrial and commercial applications include motors, heaters, and lamps. The requirements for motor

branch circuits are more robust than other load types. These requirements are provided in UL 489 and 1077 (see following section).

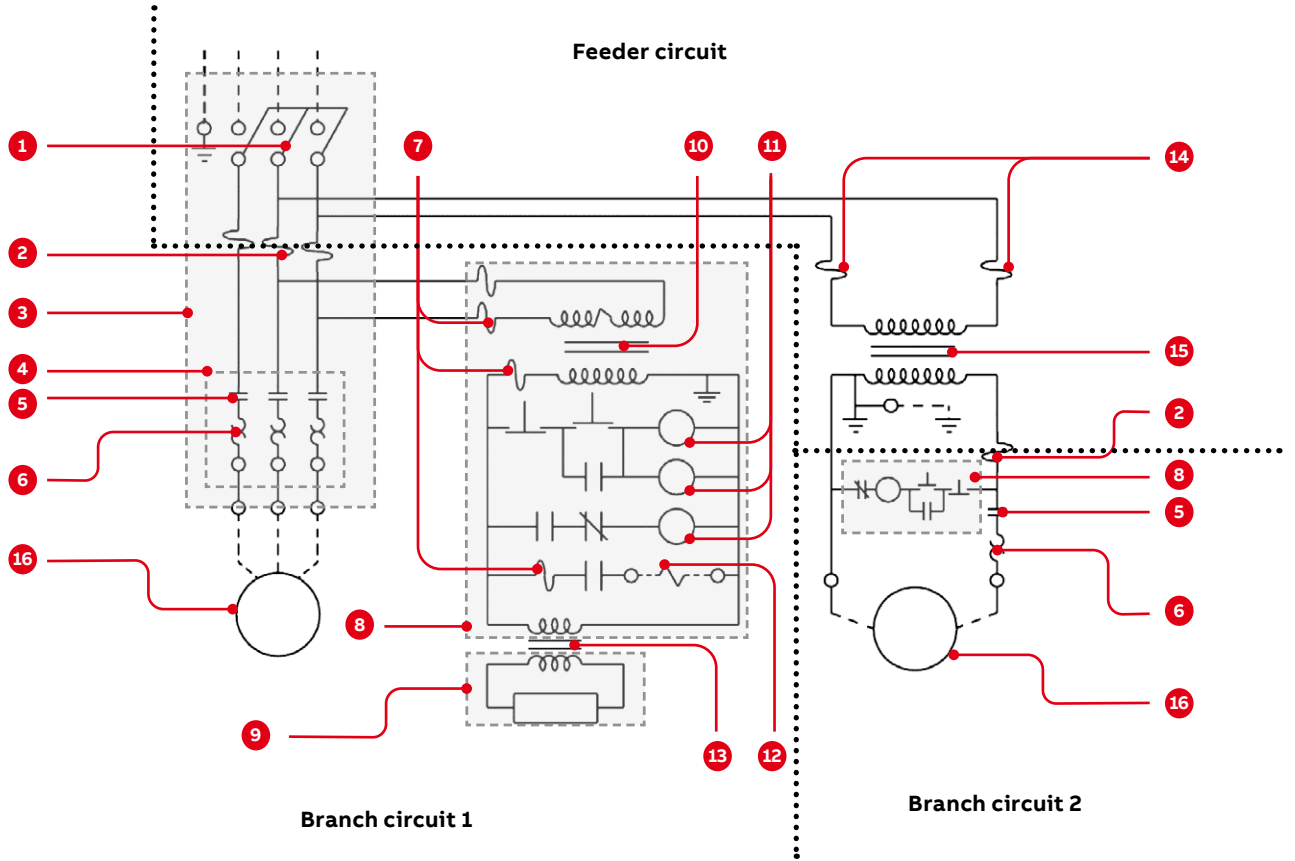

1	Fused disconnect switch acc. to UL 98, circuit breaker acc. to UL 489 or miniature circuit breaker acc. to UL 489
2	Branch circuit protective device
3	Combination motor controller
4	Starter
5	Contactor or controller
6	Overload relay and heater elements
7	Control transformer fuse or supplementary protection, so-called miniature circuit breaker acc. to UL 1077
8	Class 1 control circuit, common control circuit
9	Class 2 control circuit
10	With ground (for 1000 VA max control transformer)
11	Control circuit devices and wiring / class 1, circuit / isolated secondary circuit
12	Solenoid or other control devices (provided in the field)
13	Control transformer
14	Power transformer fuse
15	Power transformer, for motor load and control circuit
16	Load (provided in the field)

6. Introduction to UL 489 and UL 1077

For OEM machines and panel builders, the protection of their products in the event of an overload (thermal) or short-circuit (magnetic) is a critical focus. Protection can be accomplished by utilization of a circuit breaker. A circuit breaker protects the circuit components and people by interrupting the circuit when it detects a fault in the control system. Motors and other devices could suffer damage due to short-circuits without a

circuit breaker. This could lead to costly repairs or replacement of components and cause unwanted downtime.

However, determining whether UL 1077 or UL 489 circuit breakers should be utilized in a control panel or equipment can often be complicated and confusing.

6.1 UL 489 and UL 1077

The UL 489 standard covers circuit breakers (molded-case circuit breakers for the protection of service entrance, feeder, and branch circuits). These circuit breakers are specifically intended to be protected by the National Electrical Codes in Annex B, Ref. No.1. This standard also covers instantaneous-trip circuit breakers (circuit interrupters) specifically intended for use as part of a combination motor controller by the National Electrical Codes in Annex B, Ref. No.1.

UL 1077 covers supplementary protectors for use as an additional level of protection where branch circuit protection is already provided or not required. Typical applications are in control circuits or within appliances. Devices that comply with this standard are acceptable for use as a component of an end product.

It is important to note that although the term circuit breaker is used for both UL 489 and UL 1077 devices, UL 1077 devices are not considered circuit breakers by UL. They are referred to as supplementary protectors.

6.2 The difference - UL 489 and UL 1077

As previously discussed, products may be UL Listed or UL Recognized. The classification of a product as Listed vs. Recognized is a significant distinction in terms of installation and application.

Low-voltage air circuit breakers, molded-case circuit breakers, and miniature circuit breakers are subjected to a rigorous evaluation process and subsequently “Listed” to UL 489 for utilization as independent products.



In contrast, devices that are “Recognized” under UL 1077, which includes Supplementary Protectors for Use in Electrical Equipment, undergo evaluation solely for their use as components within “Listed” products.

Devices under both UL 489 and UL 1077 are required to successfully pass a series of tests, including calibration, overload, endurance, and short-circuit tests.

While the testing standards for UL 489 and UL 1077 bear similarities, the testing for UL 489 is more stringent. Notably, a product tested per the UL 489 standard must survive testing while a product tested to UL 1077 need not survive. The below table provides a comparison of the test parameters:

	UL489 Test parameters	UL1077 Test parameters
Minimum terminal spacing	½ inch up to 130 V ¾ inch up to 300 V 1 inch up to 600 V Through air	For commercial appliances 3/32 inch up to 300 V ¼ inch at terminals
Calibration test	Varies with current rating: 12 sec to 2 min at 200% < 1 hour at 135% (< 50 A) < 2 hours at 135% (> 50 A)	At 300% and at trip current +5%
Maximum temperature rise at terminal	50 °C / 122 °F	50 °C / 122 °F
Endurance test	10,000 cycles: • 6000 at In and, • 4000 mechanical no-load cycles	6000 cycles at In (S-type)
Overload test	50 cycles at 6 x In or 150 A minimum	50 cycles At 1.5 x In (general use) At 6 x In (motor starting)
Short-circuit test	<ul style="list-style-type: none"> • 1-3 times (O-C-O) at 5000 A minimum (higher for breaker rated over 100 A or 250 V) • Power factor of 4-5, must operate at 200% after 3 short-circuit operations 	<ul style="list-style-type: none"> • Does not need to continue functioning after short-circuit. • 3-7 times at 5000 A minimum and must operate @ 200% final test. • Suggested table value of 200-5000 A depending on ratings or as specified by the manufacturer.

6.3 Structural comparison: UL 489 circuit protector and UL 1077 supplementary protector

	SU201M acc. UL489	S201M acc. UL1077
		
The primary structural distinction between a UL 489 miniature circuit breaker and a UL 1077 supplementary protector lies in the mandated pole spacings. UL 489 miniature circuit breakers are easily distinguishable from 1077 supplementary protectors, as they have “fins” that establish greater spacing.	UL 489	UL 1077
Clearance (Distance over the air)	1 inch (25.4 mm)	3/8 inch (9.5 mm)
Creepage (Distance along the surface)	2 inches (50.8 mm)	1/2 inch (12.7 mm)

The decision to utilize UL 489 or UL 1077 depends on the scope of the protection desired.

A UL 489 circuit breaker is capable of protecting multiple devices simultaneously, such as an entire control panel. A UL 489 listed circuit protector can function as the final overcurrent device dedicated to safeguarding the branch circuit and outlets. It does not necessitate the wiring of an additional backup over the current device.

On the other hand, a UL 1077 supplementary protector is designed to protect a single device, except for those that feed motors or transformers and those that exit the equipment. All of these are classified as branch circuits or could be used for outlets or feeding utilization equipment. Supplementary protectors can be employed where UL 489 (branch circuit) protection is not mandated or is provided by another device.

Simply put, while a UL 489 circuit breaker can be substituted for a UL 1077 supplemental protection device, a UL 1077 supplemental protection device cannot replace a UL 489 branch circuit breaker.

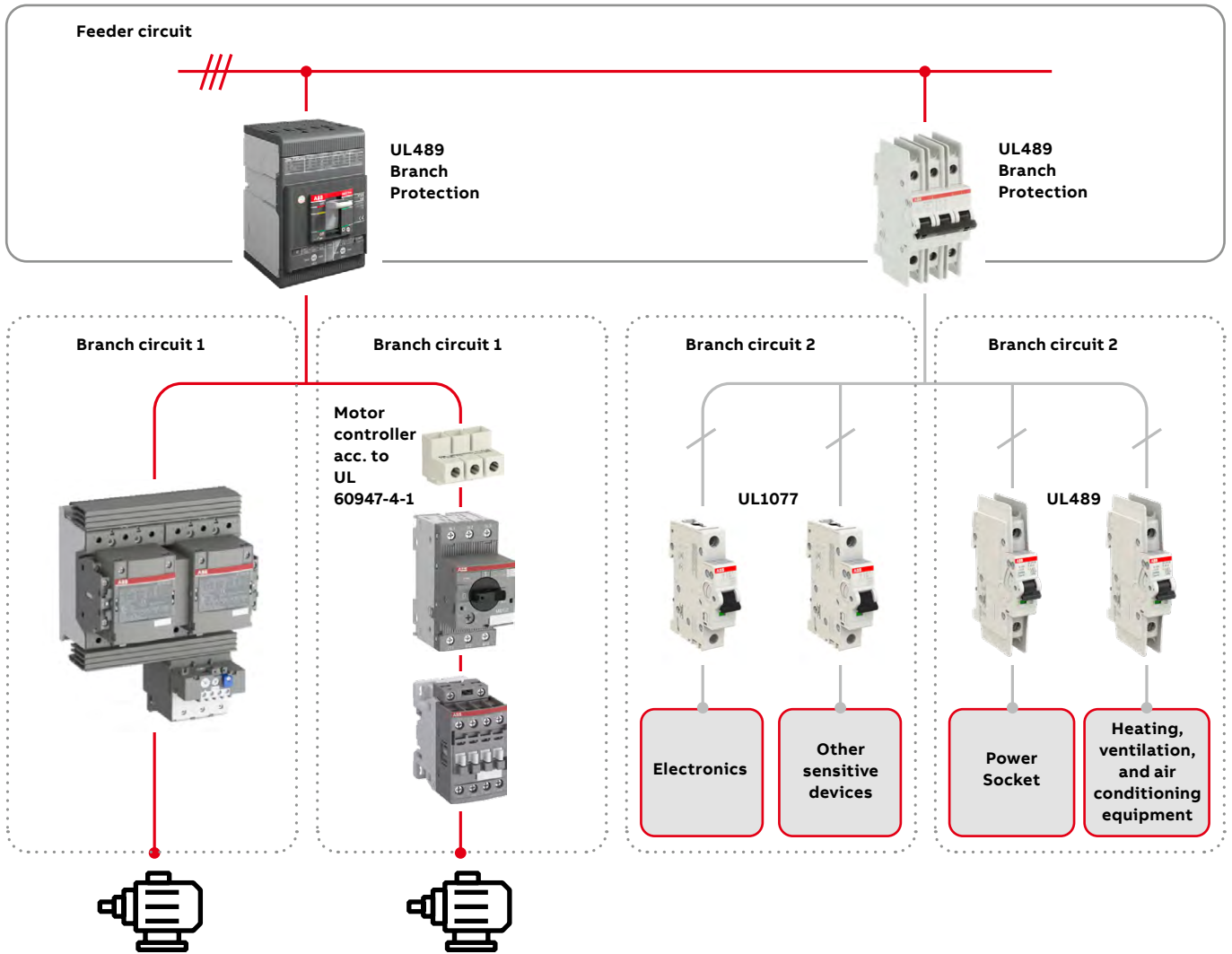

7. UL 248 – Safety low-voltage fuses

UL 248 devices include a category of fuses that are utilized for the protection of power and lighting feeders and branch circuits against overcurrent and short-circuit conditions. These devices are engineered to fulfill the requirements for current limiting fuses and are required by UL to be marked “Current Limiting” and include the following additional information: the UL/CSA fuse class, manufacturer’s name or trademark, current rating, AC and/or DC voltage rating, and AC and/or DC interrupting rating.

There are several classes of UL 248 devices, each with its distinct standards, voltage ratings, current ratings, and interrupting ratings. Some of these classes include:

- Class L: These fuses possess a voltage rating of 600 volts, AC and/or DC, current ratings of 601-6000 amps, and an interrupting rating of 200,000 amps rms symmetrical.
- Class R: These fuses have voltage ratings of 250 and 600 volts, AC; 125- and 300-volts DC, current ratings of 0-600 amps, and an interrupting rating of 200,000 amps rms symmetrical.
- Class J: These fuses have a voltage rating of 600 volts, AC, current ratings of 0-600 amps, and an interrupting rating of 200,000 amps rms symmetrical.
- Class CC/CD: These fuses have a voltage rating of 600 volts, AC, current ratings of UL Class CC: 0-30 amps and UL Class CD: 35-60 amps, and an interrupting rating of 200,000 amps rms symmetrical.

Each class of UL 248 devices has its unique applications and characteristics. For instance, Class L fuses may bear the mark “Time-Delay” even though UL does not investigate the time-delay characteristics of Class L fuses. In contrast, time delay is optional for Class R fuses.

The accurate selection and application of these devices are vital for the safe and efficient operation of electrical systems.



8. UL 98 – Switch fuse

UL 98 devices include a class of switches that have been engineered to function as disconnecting means for branch circuits, feeders, services, and motor circuits. These switches are denoted as “Enclosed and Dead-Front Switches”.

There are two primary categories of UL switches: UL 98 and UL 508. The differences between the two are substantial. Understanding the differences is essential for their accurate selection and application.

UL 98 switches are generally considered safer than UL 508 switches. They provide supplementary protections, such as an enhanced physical separation of conductor connections. UL 98 stipulates a one-inch through-the-air distance, while UL 508 specifies a half-inch. This additional distance offers increased fault protection.

Alternatively, UL 508 switches may appear more appealing than UL 98 switches due to their potential for space and cost savings. UL 508 devices focus on industrial control equipment and panels, while UL 98 specifically addresses the safety and performance requirements of enclosed and dead-front switches used as disconnecting means. The choice between the UL 508 device and the UL 98 device depends on the specific application and the type of electrical equipment involved.

Both UL 489 and UL 98 provide high short-circuit withstand and/or interrupting ratings, and both can be operated either through the enclosure door or by a flange operator.

Ultimately, the choice between UL 98 and UL 508 switches is dependent upon the specific requirements of the application, considering factors such as safety, space, and cost.



Manual operated switch-disconnectors/switches

9. Combination motor controller components according to UL 60947-4-1 (formerly UL 508)

UL 60947-4-1 is the result of a harmonization of two standards, UL 508 and IEC 60947-4-1. The standard deals with the coordination between the branch circuit protective device and the motor starter. In the meantime, it distinguishes between the coordination type “1” and type “2” normal and heavy start-ups. The standard specifies how the “combination motor controllers” must be manufactured and, accordingly, are classified by construction types.

The motor starter for starting or stopping an engine is usually composed of one or more devices for disconnecting and protecting the motor and other components against short-circuits and earth faults. The starter enables motor control and protects against overload.

According to Article 409 of the National Electrical Code (NFPA 70), industrial control panels must be marked with their SCCR. As discussed previously, and as specified in the National Electrical Code (NEC), UL 508A Supplement SB, the Standard for Industrial Control Panels, provides an accepted method for determining the SCCR of the control panel. Industrial control panel manufacturers can use the spreadsheets below for guidance. They are intended for those manufacturers that purchase the discrete components and assemble combination motor controllers within their panels to achieve a combination SCCR that is higher than the lowest-rated individual component.

Tables are available on the UL website which identifies combinations of components that can be used in a manufacturer’s listed industrial control panel without further evaluation or specific documentation. This information on the manufacturer’s UL Solutions procedure pages is kept up-to-date by the manufacturers and can be found under the following [LINK](#).

Database Identification Number ABB, DE for Germany	Construction Type	Component Description								Combination Motor Controller Ratings					Enclosure Volume, Cubic Inches	Conditions of Use	File Reference	
		Component Type Abbreviation	Manufacturer Name	Complete Part Number	Voltage, V	Number of Phases	SCCR, kA	Full Load Current, A	Hp Rating	Voltage, V	Number of Phases	SCCR, kA	Current Rating, FLA or FLA/LRA	Hp Rating			UL File Number	Volume / Section (Volts) (Sec#)
480Y/277 V AC, 3-PHASE																		
ABB DE 4200.01	F	MSP MC ACC (Adaptor) ACC (Close coupler)	ABB Stotz-Kontakt GmbH ABB France ABB Stotz-Kontakt GmbH ABB France BEA16-4 (optional)	MS132-0.16 AF09 S1-M3-25 -	480Y/277 480 -	3 5 -	10 7.6 -	0.10 - 0.16 5 -	480Y/277	3	100	0.16 FLA / 0.96 LRA	-	218	1.5,8	E345003	1.2	
ABB DE 4200.02	F	MSP MC ACC (Adaptor) ACC (Close coupler)	ABB Stotz-Kontakt GmbH ABB France ABB Stotz-Kontakt GmbH ABB France BEA16-4 (optional)	MS132-0.16 AF12 S1-M3-25 -	480Y/277 480 -	3 5 -	10 11 -	0.10 - 0.16 7.5 -	480Y/277	3	100	0.16 FLA / 0.96 LRA	-	218	1.5,8	E345003	1.2	
ABB DE 4200.03	F	MSP MC ACC (Adaptor) ACC (Close coupler)	ABB Stotz-Kontakt GmbH ABB France ABB Stotz-Kontakt GmbH ABB France BEA16-4 (optional)	MS132-0.16 AF16 S1-M3-25 -	480Y/277 480 -	3 5 -	10 18 -	0.10 - 0.16 10 -	480Y/277	3	100	0.16 FLA / 0.96 LRA	-	218	1.5,8	E345003	1.2	
ABB DE 4200.04	F	MSP MC ACC (Adaptor) ACC (Close coupler)	ABB Stotz-Kontakt GmbH ABB France ABB Stotz-Kontakt GmbH ABB France BEA26-4 (optional)	MS132-0.16 AF26 S1-M3-25 -	480Y/277 480 -	3 5 -	10 21 -	0.10 - 0.16 15 -	480Y/277	3	100	0.16 FLA / 0.96 LRA	-	218	1.5,8	E345003	1.2	
ABB DE 4200.05	F	MSP MC ACC (Adaptor) ACC (Close coupler)	ABB Stotz-Kontakt GmbH ABB France ABB Stotz-Kontakt GmbH ABB France BEA26-4 (optional)	MS132-0.16 AF30 S1-M3-25 -	480Y/277 480 -	3 5 -	10 27 -	0.10 - 0.16 20 -	480Y/277	3	100	0.16 FLA / 0.96 LRA	-	218	1.5,8	E345003	1.2	
ABB DE 4200.06	F	MSP MC ACC (Adaptor) ACC (Close coupler)	ABB Stotz-Kontakt GmbH ABB France ABB Stotz-Kontakt GmbH ABB France BEA26-4 (optional)	MS132-0.16 AF38 S1-M3-25 -	480Y/277 480 -	3 5 -	10 34 -	0.10 - 0.16 25 -	480Y/277	3	100	0.16 FLA / 0.96 LRA	-	218	1.5,8	E345003	1.2	
ABB DE 4200.07	F	MSP MC ACC (Adaptor) ACC (Close coupler)	ABB Stotz-Kontakt GmbH ABB France ABB Stotz-Kontakt GmbH ABB France BEMC/132 (optional)	MS132-0.16 MC1 S1-M3-25 -	480Y/277 480 -	3 5 -	10 7.6 -	0.10 - 0.16 5 -	480Y/277	3	5	0.16 FLA / 0.96 LRA	-	218	1.5,8	E345003	1.2	
ABB DE 4200.08	F	MSP MC ACC (Adaptor) ACC (Close coupler)	ABB Stotz-Kontakt GmbH ABB France ABB Stotz-Kontakt GmbH ABB France BEMC/132 (optional)	MS132-0.16 MC2 S1-M3-25 -	480Y/277 480 -	3 5 -	10 11 -	0.10 - 0.16 7.5 -	480Y/277	3	5	0.16 FLA / 0.96 LRA	-	218	1.5,8	E345003	1.2	







The UL Solutions site covers the application of individual components, including a disconnecting means, an overcurrent protective device, a motor controller, motor overload protection, and a combination motor controller with specified ratings, including an SCCR. To qualify for this exception from further evaluation, each component must be listed or recognized to the requirements for the applicable component standard.

The specified ratings for the combination motor controller may be applied to the end-product equipment only when all of the specific compo-

nents listed are provided in the end-product equipment and installed according to any applicable conditions of acceptability.

Components other than those identified as compliant in the combination motor controller and connected to the power circuit of the combination motor controller will require additional evaluation by the local AHJ.

The figure below shows the current six construction types for Combination Motor Controllers.

Tested in an enclosure	Type A	Type C	Type D	Type E	Type F (two-component)	Type F (three-component)
 Disconnect means	Motor disconnect UL 98 or UL 489	Inverse-time circuit- breaker UL 489	Instantaneous trip circuit-breaker UL 489 	Self- protected control device UL 60947-4-1	Manual self-protected combination controller UL 60947-4-1	Manual self-protected combination controller UL 60947-4-1
 Short-circuit and ground-fault protection	Fuses UL 248					
 Control means	Magnetic or solid-state motor controller UL 60947-4-1	Magnetic or solid-state motor controller UL 60947-4-1	Magnetic or solid-state motor controller UL 60947-4-1		Magnetic or solid-state motor controller UL 60947-4-1	Magnetic or solid-state motor controller UL 60947-4-1
 Overload protection	Overload relay UL 60947-4-1	Overload relay UL 60947-4-1	Overload relay UL 60947-4-1		Manual self-protected combination controller UL 60947-4-1	Overload relay UL 60947-4-1
 Tested combination SCCR	Straight voltage rated (e.g. 480 Δ)	Straight voltage rated (e.g. 480 Δ)	Straight voltage rated (e.g. 480 Δ)		Slash voltage rated (e.g. 480 Y/277 V)	Slash voltage rated. (e.g. 480 Y/277 V)

Defining Combination Motor Controllers (NKJH)

Note: the information above is derived from UL 60947-4-1 and is intended for reference purposes only.

9.1 Type A combination motor controller consisting of a disconnect switch, fuses, motor controller, and overload relay

The Type A combination motor controller is a comprehensive solution encompassing a disconnect switch, fuses, motor controller, and overload relay. Distinctively, Type A stands out as the sole motor starter necessitating a fuse, which serves a dual purpose as magnetic protection and a Branch Circuit Protective Device (BCPD). The inclusion of this fuse is crucial for safeguarding against short-circuit currents and providing insulation for the branch circuit.

The Type A combination motor controller is a comprehensive solution designed to efficiently manage and protect electric motors. It consists of four essential components: a disconnect switch, fuses, motor controller, and overload relay.

Disconnect switch and fuses (UL 98):

- The combination begins with an OT disconnect switch, meeting UL 98 standards, which ensures safe disconnection when needed.
- A unique feature of the Type A combination is the inclusion of fuses. These fuses serve a dual purpose – acting as magnetic protection and functioning as a Branch Circuit Protective Device (BCPD). Essentially, they play a crucial role in protecting against short-circuit currents and providing insulation for the branch circuit.

Contactors with motor controller function (UL 60947-4-1):

- For precise control of the motor, the system incorporates an AF series contactor for example. This component enhances the accuracy and efficiency of load control, allowing for smooth start, stop, and overall operation of the motor.

Overload relay (UL 60947-4-1):

- The overload relay is a vital component designed to prevent motor damage due to excessive load or overheating.
- The system offers flexibility by allowing the configuration of the overload relay with either for example the TA25DU or TF42, providing adaptability and optimizing performance based on specific requirements.

Type A combination motor controller

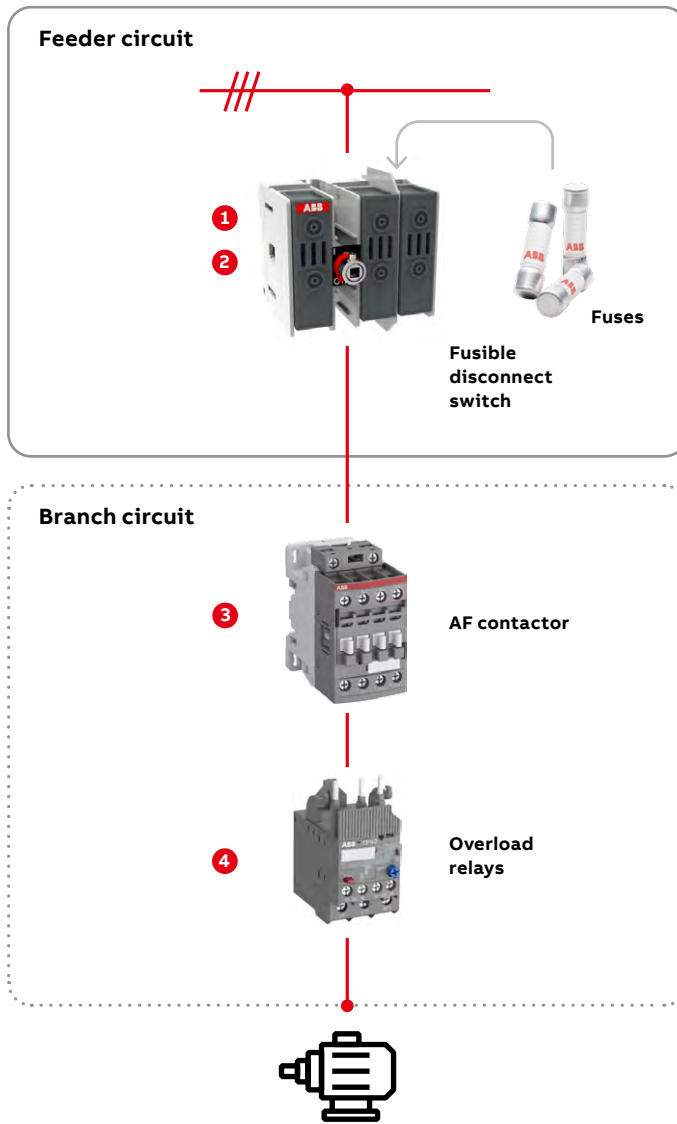

Branch functional requirements

- 1 Disconnect means
- 2 Short-circuit and ground-fault protection
- 3 Control means
- 4 Overload protection

9.2 Type C combination motor controller consisting of inverse time circuit breaker, motor controller, and overload relay

A motor starter combination, Type C, is a setup designed to ensure the safe and efficient operation of an electric motor. This combination should include specific components, each serving a crucial role in protecting the motor and the electrical circuit it operates on.

Inverse time circuit breaker:

- This component, often implemented through a circuit breaker, plays a vital role in ensuring safety. It adheres to the UL 489 standard.
- The Inverse Time Circuit Breaker is designed to interrupt the circuit when necessary. It acts as a safeguard, capable of protecting the electrical system from faults or abnormalities that could otherwise lead to damage or hazards.

Contactor with motor controller function (UL 60947-4-1):

- The contactor is a key element in the Type C combination, following the UL 60947-4-1 standard.
- It serves as a switch for the motor, controlling its operation. The motor controller function ensures a smooth and controlled start, stop, and overall operation of the motor.

Overload relay (UL 60947-4-1):

- The overload relay, by UL 60947-4-1, is a crucial protective component in the combination.
- Its primary role is to safeguard the motor from overload situations. If the motor draws excessive current, indicating a potential overload, the overload relay intervenes, preventing damage to the motor and promoting longevity.

Type C combination motor controller

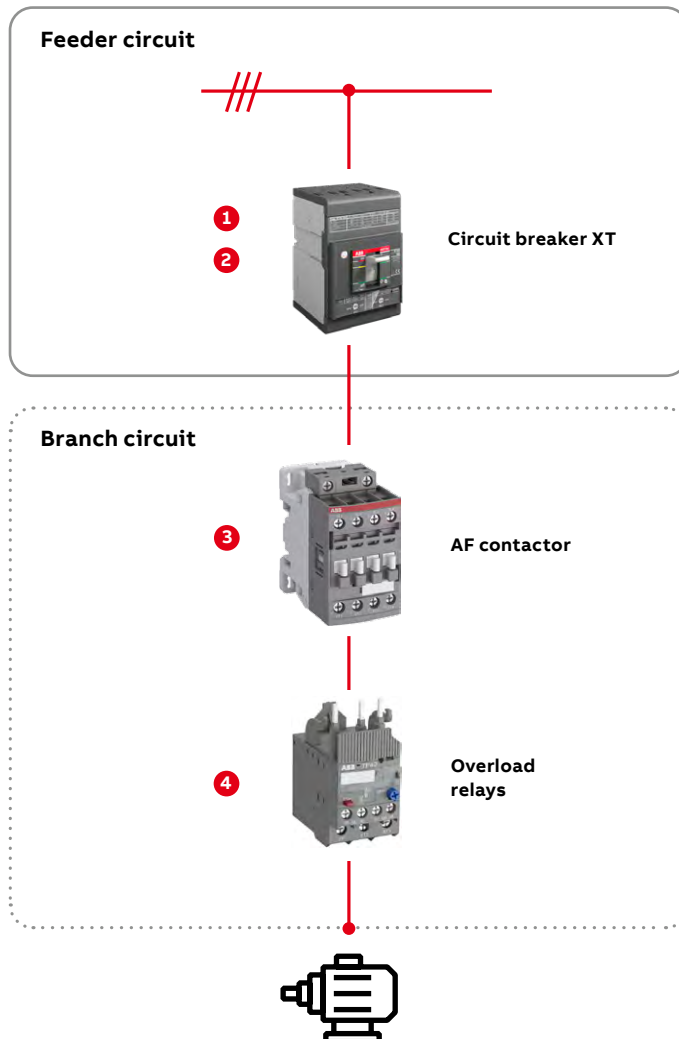

Branch functional requirements

- 1 Disconnect means
- 2 Short-circuit and ground-fault protection
- 3 Control means
- 4 Overload protection

9.3 Type D combination motor controller consisting of an instantaneous trip circuit breaker, motor controller, and overload relay

The Type D combination motor controller is a specialized solution designed to efficiently control and protect electric motors. It comprises three key components: an instantaneous trip circuit breaker, a motor controller, and an overload relay.

Instantaneous trip circuit breaker:

- The core element of the Type D combination is the instantaneous trip circuit breaker. This circuit breaker is designed to quickly and immediately interrupt the circuit in the event of a fault.
- Unlike other types, the Type D combination relies on this specific circuit breaker for protection, emphasizing rapid response to ensure the safety of the electrical system.

Motor controller:

- The motor controller is a fundamental part of the combination, overseeing the start, stop, and overall operation of the motor.
- It ensures precise control over the motor's functioning, contributing to smooth operation and efficient performance.

Overload relay:

- Similar to other combinations, the Type D includes an overload relay. This component is crucial for preventing motor damage caused by overloads or overheating.
- The overload relay acts as a safeguard, intervening when the motor operates under conditions that could lead to excessive current or temperature, thereby protecting the motor and ensuring its longevity.

Type D combination motor controller

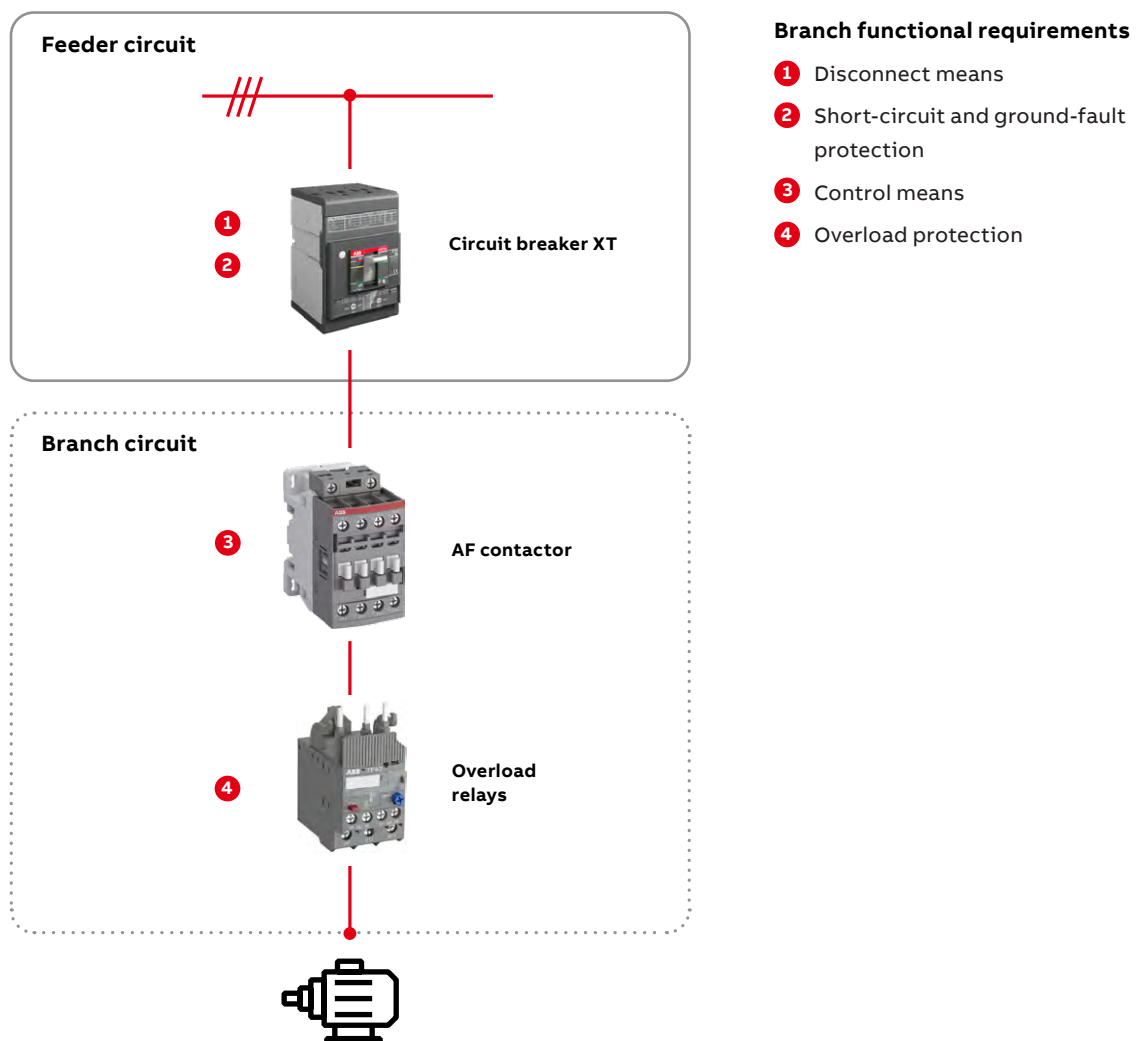

9.4 Type E (self-protected) combination motor controller consisting of manual self-protected combination motor controller and motor controller

Type E represents the only CMC construction type to allow the use of a single component. Manual motor starters are the most common example. The term “self-protected” refers to the level of coordinated protection provided, as these combinations are subject to an intense validation process following short-circuit, including thousands of electrical and mechanical operations.

TS1-M3-S1 | ABB *this has a new design*

TS1-M3-S1 | ABB *this has a new design*

Due to the compact nature of manual motor starters, Type E Combination Motor Controllers are slash voltage rated (e.g. 600Y/347 V AC). This limits their use to solidly grounded networks for higher voltages (e.g. above 347 V AC).

Two additional criteria exist for manual motor starters certified as combination motor controllers:

The combination must provide:

- line-side terminal spacing of 2 inches over-surface (creepage) and 1 inch through-air (clearance) which are similar to the requirements common for UL 489 / CSA C22.2 No.5 circuit-breakers.
- A means of visibly differentiating between thermal (overload) and magnetic (short-circuit) trips to facilitate troubleshooting.

These requirements can be met using either accessories (e.g. terminal feeder blocks and side-mount trip indicators) or inherent design features. Manual Motor Starter MS165 requires no additional accessories to meet the above criteria. MS132 requires only the line-side terminal feeder block (S1-M3-...) to meet the criteria. Both types feature an integral trip indicator window, which turns red upon tripping the instantaneous release, indicating a short-circuit.

Type E manual self-protected combination motor controllers provide significant advantages for customers by incorporating all four of the required features (control, disconnect, overload, and short-circuit protection) into one, compact and cost-efficient product.

Type E self-protected combination motor controller

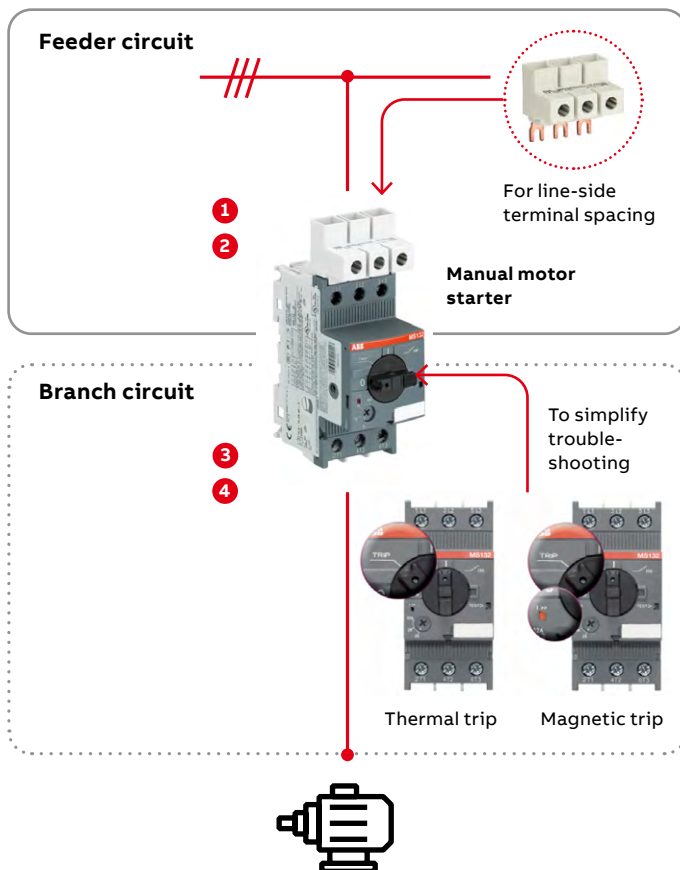

Branch functional requirements

- 1 Disconnect means
- 2 Short-circuit and ground-fault protection
- 3 Control means
- 4 Overload protection

Application information:

- Starting method: Manual
- SCCR reference: “Type E”
- Maximum voltage: 600Y/347 V
- Upstream branch protection: Not required

9.5 Type F combination motor controller consisting of manual self-protected combination motor controller and motor controller

Type F combinations are divided into two styles: two-component and three-component assemblies. Two-component Type F assemblies utilize a manual, self-protected device for both short-circuit and overload protection. Three-component Type F assemblies utilize a separate overload relay with short-circuit protection provided by a magnetic-only (MO) manual motor starter.

The additional criteria for line-side terminal spacing and visible trip indication described below are also applicable for Type F Combination Motor Controllers.

Type F combination motor controllers can be tested for either Type 1 or Type 2 coordination.

With the inclusion of a contactor for remote control, Type F Combination Motor Controllers increase functionality while still offering the benefit of using compact and cost-efficient manual motor starters for branch short-circuit protection.

Three-component assemblies provide additional benefits, including selectable Class 10, 20, and 30 overload protection (electronic), along with a wiring schematic identical to that of a conventional magnetic combination starter (e.g. molded case circuit-breaker, contactor, and overload relay).

Type F combination motor controllers

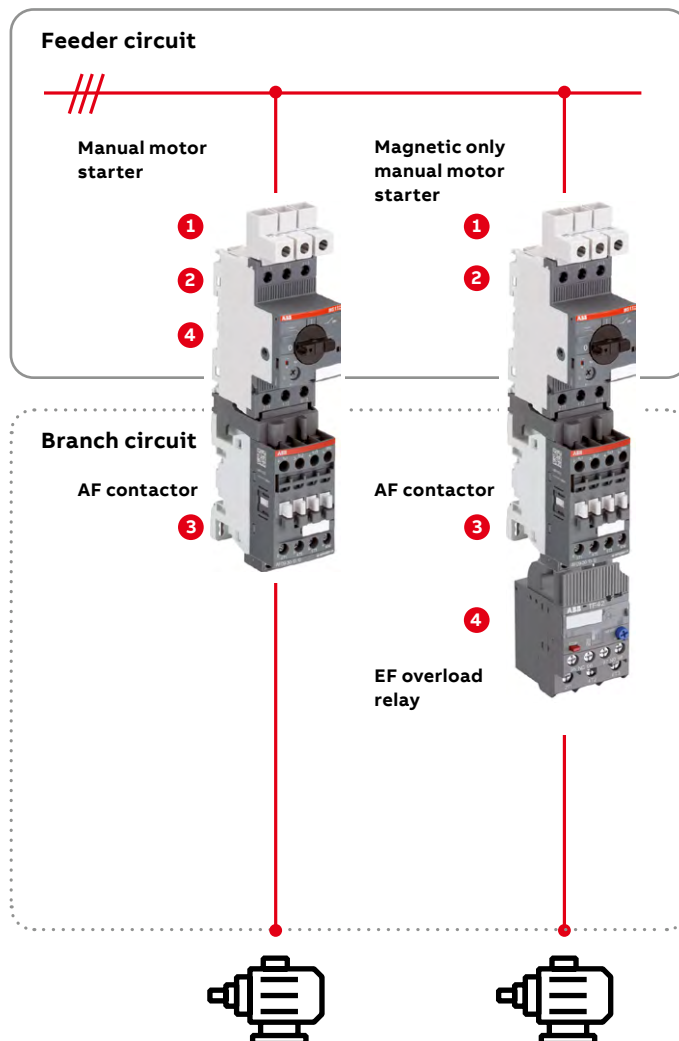

Branch functional requirements

Two-component assemblies on the left side and three-component assemblies on the right.

- 1 Disconnect means
- 2 Short-circuit and ground-fault protection
- 3 Control means
- 4 Overload protection

Application information:

- Starting method: Remote
- SCCR reference: "Type F"
- Maximum voltage: 600Y/347 V
- Upstream branch protection: Not required

10. Softstarters in UL Control Panels

With Softstarters ABB offers another motor starting solution for UL control panels. Softstarters add value to your business by securing motor reliability, improving installation efficiency and increasing application productivity. ABBs softstarters are UL listed and are covered by UL component recognition allowing a safe and reliable use in various applications.

—

References to UL Standards

- **UL 508A:** This standard covers the construction and performance of industrial control panels intended for general industrial use. It includes requirements for components, wiring, and protection to ensure safety and reliability.
- **UL 508:** This standard applies to industrial control equipment, including motor controllers and softstarters. It ensures that these components meet specific safety and performance criteria.
- **UL 60947-4-2:** This standard is part of the IEC 60947 series and applies to low-voltage switchgear and control gear, including softstarters. It ensures compatibility and safety in industrial applications.

—

Coordination with protection devices

Proper coordination between softstarters and protection devices is crucial for ensuring the safety and reliability of motor control systems. Here are some key aspects:

- **Short-Circuit Protection**
 - **Devices:** Circuit breakers or fuses are used to protect against short-circuit conditions. These devices must be selected to ensure they can handle the fault current without causing damage to the softstarter or motor.

- **Testing**

- The combination of the softstarter and the protection device must be tested under extreme fault conditions to ensure they can clear the fault quickly and safely.

- **Overload Protection**

- Overload relays are used to protect the motor from excessive current that can cause overheating. These relays can be thermal or electronic and are typically integrated into the softstarter or installed separately.

- **Coordination**

- The overload protection device must be coordinated with the softstarter to ensure it trips before the motor reaches a critical temperature, preventing damage.



All UL component ratings provided in ABB's Selected Optimized Coordination (SOC) tool for soft starters have been thoroughly tested and verified. This includes both scenarios – whether external overload protection is used or if integrated protection is available. The SOC tool ensures compliance and coordination based on verified testing data, offering reliable and accurate results for your applications. Here the [link](#).

—

Softstarters portfolio

ABB Softstarters offering consists of four ranges, covering every need. The products help you secure motor reliability, improve installation efficiency and increase application productivity.



Product features overview		PSR	PSRC	PSE	PSTX
	Motor protection	–	–	Medium	High
	Installation efficiency	Basic	Basic	Medium	High
	Application enhancement	Basic	Basic	Medium	High

Technical overview

Technology	Basic	Basic	General	Advanced
Motor size	Small – up to 105 A	Small – up to 105 A	Medium – up to 370 A	Large – up to 1250 A
Application	All	Scroll compressor	All	All
Torque control	–	–	Yes	
Heavy duty starts	–	–	Yes	

Communication protocols

Built-in communications	–	–	Modbus RTU	Modbus RTU
Fieldbus (optional accessories)	Modbus RTU, Profibus, DeviceNet	Modbus RTU, Profibus, DeviceNet	Modbus RTU, Profibus, DeviceNet, Modbus TCP	Modbus RTU, Profibus, DeviceNet, Modbus TCP
Anybus (optional accessories)	–	–	–	Profibus, DeviceNet, Modbus-RTU, BACnet IP, EtherNet/IP, Modbus TCP, Profinet, BACnet MS/TCP, EtherCat

Certifications and approvals

Certifications	CE, cULus, CCC, EAC, ANCE, C-tick, KC	CE, cULus, CCC, EAC, ANCE, C-tick, KC	CE, cULus, CCC, EAC, ANCE, C-tick, KC	CE, cULus, CCC, EAC, ANCE, C-tick, KC
Approvals			ABS, DNV, Lloyd's register, CCS, PRS, Class NK	ABS, DNV, Lloyd's register, CCS, PRS, Class NK



Secure Motor Reliability

ABB softstarters help increase your motors lifetime by protecting it from electrical stress. Starting currents are easily optimized to your load, application and motor size. Over ten motor protection features are included to keep your motor safe from different load and network irregularities.

Secure motor reliability	PSR	PSRC	PSE	PSTX
Soft starter and stops	●	●	●	●
Current limit	–	–	●	●
Current limit ramp and dual current limit	–	–	–	●
Electronic motor overload protection	–	–	●	●
Dual overload protection	–	–	–	●
Underload protection	–	–	●	●
Power factor underload protection	–	–	–	●
Locked motor protection	–	–	●	●
Current/Voltage imbalance protection	–	–	–	●
Phase reversal protection	–	–	–	●
Customer defined protection	–	–	–	●
Motor heating	–	–	–	●
PTC/PT100 input for motor protection	–	–	–	●
Overvoltage/undervoltage protection	–	–	–	●
Earth-fault protection	–	–	–	●



—
Improve installation Efficiency

Reduce your installation time and panel size by having all features you need built into your soft-starter. Our softstarters are easy to install thanks to their compact design and many built-in features. The built-in bypass saves energy and space while reducing heat generation. A complete motor starting solution in one unit.



—
Increase application Productivity

Reduce the number of stops in your production by allowing your softstarter to do more than just starting. Our softstarters reduce the mechanical stress on your motor application, which will increase your uptime. Torque control, pump cleaning, motor brake and many other features enable you to operate your process at its full potential.



—
PSTX enclosed softstarters

Short circuit protection

To handle the role of short-circuit protection and disconnection, the PSTX-ND series utilizes the Tmax® XT molded case circuit breaker to provide the utmost protection under short circuit conditions, with a short circuit rating of 65 kAIC up to the X700 unit. The X900 and X1000 units are protected with Class L fuses with a short circuit rating of 100 kAIC.

Electronic overload protection

Every PSTX softstarter comes with integral electronic overload protection that is adjustable to four different tripping classes, preset to Class 10 tripping for normal-duty applications.

Improve installation efficiency	PSR	PSRC	PSE	PSTX
Built-in bypass	●	●	●	●
Inside-delta connection possible	—	—	—	●
Graphical display and keypad	—	—	●	●
Detachable keypad	—	—	—	●
Motor runtime and start count	—	—	—	●
Programmable warning functions	—	—	—	●
Diagnostics	—	—	—	●
Overload time-to-trip	—	—	●	●
Overload time-to-cool	—	—	—	●
Analog output	—	—	●	●
Fieldbus communication	●	●	●	●
Event log	—	—	●	●
Multiple languages	—	—	—	17
Electricity metering	—	—	—	●

Increase application productivity	PSR	PSRC	PSE	PSTX
Torque control	—	—	●	●
Torque limit	—	—	—	●
Coated PCBA	—	—	●	●
Limp mode	—	—	—	●
Jog with slow speed forward/reverse	—	—	—	●
Dynamic brake	—	—	—	●
Stand still brake	—	—	—	●
Sequence start	—	—	—	●
Full voltage start	—	—	—	●
Kick start	—	—	●	●
Automatic pump cleaning	—	—	—	●

● = Built-in, ● = Optional, — = Not available

This feature also allows the unit to select Class 30 tripping for heavy-duty applications, per the selection guide chart.

The PSTX softstarter

Designed around the PSTX softstarter with all the exceptional standard features inherent to the open PSTX shown below. The enclosed offer also comes with the following additional features:

- UL 508A label
- UL 3-wire service entrance rating up to and including the X700 design
- NEMA Type 4 enclosure meets NEMA 1, 12, 3R and 4 protection requirements
- Door-mounted keypad and six pilot devices
- Built-in Modbus-RTU communications
- Optional Anybus communication modules available for most communication protocols

For more details, please refer to the respective document:

[PSTX-ND Enclosed Softstarters Brochure](#)

(For normal-duty and heavy-duty applications)

[PSTX-XD Enclosed Softstarters Brochure](#)

(For heavy-duty applications with emergency bypass)

11. ABB Drives in UL Control Panels

UL 508A is the Underwriters Laboratories (UL) safety standard for industrial control panels in North America, ensuring these panels are safe for end-users. ABB drives, which control motor speed, torque, and direction, are often integral to these control panels in various industries (HVAC, water, and industrial automation). In UL 508A panels, the drives are typically designed to meet specific safety and performance standards, including requirements for protection, grounding, enclosure types, and wiring practices.

Reference to the UL Standard

The UL 508A standard covers various sections relevant to ABB drives:

- **Component Requirements:** UL 508A requires that all major components, such as drives, meet UL-listed standards (like UL 61800-5-1 for adjustable speed drives).
- **Short-Circuit Current Rating (SCCR):** Control panels must have an SCCR, which ABB drives must also support. SCCR ensures the drive can handle short circuits safely, which is crucial in coordinating with other protection devices.
- **Temperature Ratings and Enclosures:** The drives in a UL 508A panel must meet specific temperature ratings based on the environment and be placed in appropriate enclosures, such as NEMA-rated types for added protection against environmental factors.
- **Protective Features:** The drives in UL 508A panels must be installed with considerations for overcurrent protection, grounding, and clear labeling.

Coordination with Protection Devices

When selecting and installing ABB drives in UL 508A panels, coordination with protective devices is crucial:

- **Overcurrent Protection:** Drives must be paired with protection devices that meet UL requirements. Fuses or circuit breakers certified by UL ensure that drives are protected from overcurrent without compromising safety.

- **Selective Coordination:** In fault conditions, drives must isolate the affected circuit to prevent shutdown of other equipment. Properly selected protection devices help achieve selective coordination, ensuring minimal disruption during faults.
- **Short-Circuit Coordination:** Drives need to withstand short circuits without causing panel failures, ensuring a safe restart when protection devices are reset. ABB drives are often selected with short-circuit ratings that align with the SCCR requirements of the UL 508A panel.

Overview of ABB Drive Types for UL Control Panels

ABB provides a range of drives suitable for use in UL 508A control panels:

- **ACS580:** A general-purpose drive that supports various industrial applications. UL listed and suitable for integration in control panels requiring UL certification.
- **ACS880:** A high-performance industrial drive designed for advanced applications. These drives are UL listed and offer extensive control options, making them ideal for complex control panel setups.
- **ACH580:** Designed primarily for HVAC applications, it meets UL standards and can be used in UL 508A HVAC control panels with features tailored to ventilation and air conditioning systems.
- **DCS800:** A DC drive that is also compatible with UL 508A standards, suitable for applications requiring DC motor control, especially in older systems where DC motors are still prevalent.
- **Micro Drives (ACS55, ACS150, ACS355):** Compact, cost-effective drives for basic applications, UL listed and suitable for simple control panel setups.

Each of these drives has documentation and ratings available from ABB to assist with UL 508A panel integration, including SCCR ratings, protective coordination guidelines, and setup instructions for compliance.

12. NEMA Standard for Industrial Control Panels

The National Electrical Manufacturers Association (NEMA) establishes the standards for industrial control panels in the United States. These specifications guarantee the effectiveness, dependability, and safety of electrical systems. Comprehending and adhering to NEMA guidelines is crucial for manufacturers and exporters seeking to thrive in the US marketplace.

NEMA Standards Overview

NEMA standards cover a wide range of electrical products and systems. NEMA standards are used by Underwriters Laboratories (UL) and the Canadian Standards Association (CSA) as guidelines for listing and investigating electrical needs. Components that pass the required tests and meet the applicable standards are authorized to carry a label from UL or CSA. For industrial control panels, the most relevant standards include:

- **NEMA ICS (Industrial Control and Systems):**

- **Focus:** General requirements for ratings, construction, testing, performance, and manufacture of industrial control and systems equipment:
 - **NEMA ICS 1:** General Requirements. Provides general information on ratings, construction, testing, performance, and manufacture of industrial control and systems equipment.
 - **NEMA ICS 2:** Controllers, Contactors, and Overload Relays Rated 600 Volts. Covers requirements for controllers, contactors, and overload relays used in industrial control systems.
 - **NEMA ICS 3:** Medium Voltage Controllers Rated 2,001 to 7,200 Volts AC. Specifies requirements for medium voltage controllers used in industrial applications.
 - **NEMA ICS 6:** Enclosures. Covers enclosure requirements for all industrial control devices operating on commercial voltages up to 750 V DC or up to 7,200 V AC.
- **Example:** NEMA ICS 1-2022 provides practical information on these aspects.

- **NEMA AB (Molded Case Circuit Breakers):**

- **Focus:** Standards for molded case circuit breakers and their application in industrial control panels.
 - **NEMA AB 1:** General requirements for molded case circuit breakers.
 - **NEMA AB 3:** Molded case circuit breakers and molded case switches for use in enclosures.
 - **NEMA AB 4:** Guidelines for the inspection and preventive maintenance of molded case circuit breakers used in commercial 1 and industrial applications.
 - **NEMA AB 5:** Focus: Selective coordination of low-voltage circuit breakers.
- **Example:** NEMA AB 1 covers the requirements for molded case circuit breakers used in industrial control panels.

- **NEMA PB (Panelboards):**

- **Focus:** Standards for panelboards, including their construction, voltage ratings, short-circuit current ratings, and test procedures.
 - **NEMA PB 1:** Focus: General requirements for panelboards rated 1000 volts or less.
 - **NEMA PB 1.1:** Focus: Instructions for the proper installation, operation, and maintenance of panelboards rated 1000 volts or less.
 - **NEMA PB 2:** Focus: Deadfront distribution switchboards.
 - **NEMA PB 2.2:** Focus: Application guide for ground-fault protective devices for equipment.
- **Example:** NEMA PB 1-2023 provides guidelines for the proper installation, operation, and maintenance of panelboards rated 1000V or less.

Key Components of NEMA Industrial Control Panels

- **Circuit Breakers and Fuses:** Essential for protecting electrical circuits from overloads and short circuits. Common standards include UL 489 for circuit breakers and UL 248 for fuses.
- **Power Supplies:** Provide the necessary power to control circuits and devices. Must comply with NEMA and UL standards for safety and performance.
- **Relays and Contactors:** Used for switching and controlling electrical loads. These components must meet NEMA ICS standards for reliability and durability.
- **Enclosures:** Protect internal components from environmental factors such as dust, water, and chemicals. NEMA ICS 6 specifies the requirements for different types of enclosures based on the environment they will be used in.

NEMA standards for low voltage products are designed to ensure safety, reliability, and performance across various applications. These products are typically rated as 1,000 volts or lower and are intended to operate at nominal frequencies of 50Hz or 60Hz. The materials used in these products must be durable and suitable for the environment in which they will be used. This includes ensuring that the design prevents accidental contact with live parts and can withstand mechanical stress.

Compliance and Certification

Achieving compliance with NEMA standards involves rigorous testing and certification processes. Key steps include:

- **Design Verification:** Ensuring that the design of the control panel meets all relevant NEMA standards.
- **Component Testing:** Individual components must be tested and certified to meet NEMA and UL standards.
- **Final Assembly Testing:** The fully assembled control panel must undergo testing to verify overall compliance.

Benefits of NEMA Compliance

- **Safety:** Ensures that control panels are safe to operate and maintain.
- **Reliability:** Enhances the reliability and longevity of electrical systems.
- **Market Access:** Facilitates entry into the US market by meeting local regulatory requirements.
- **Customer Confidence:** Builds trust with customers by demonstrating adherence to recognized standards.
- **Standardization:** Speeds up the design process by making it easier to select products that adhere to the NEMA standards.

—

What are the specific requirements for enclosures according to NEMA standards?

NEMA standards for enclosures are detailed in the ANSI/NEMA 250-2020 standard, which specifies the construction, testing, rating, and marking requirements for enclosures used to protect electrical equipment. Here are some key points:

Types of NEMA Enclosures

NEMA enclosures are categorized based on their intended environment and the level of protection they provide:

- Indoor Enclosures:
 - **Type 1:** General-purpose, protects against light dust, dirt, and accidental contact.
 - **Type 2:** Similar to Type 1 but with added protection against dripping and light splashing of liquids.
 - **Type 5:** Dust-tight, protects against dust and falling dirt.
 - **Type 12 and 12K:** Protects against dust, dirt, and dripping non-corrosive liquids.
 - **Type 13:** Protects against dust, spraying of water, oil, and non-corrosive coolants.
- Indoor/Outdoor Enclosures:
 - **Type 3, 3X, 3R, 3RX, 3S, 3SX:** Protects against rain, sleet, snow, and external ice formation:
 - **X:** Stands for **corrosion resistance**.
 - **R:** Stands for **rain** protection.
 - **S:** Stands for **snow and ice**.
 - **Type 4 and 4X:** Watertight and dust-tight, protects against splashing water, hose-directed water, and corrosion (4X).
 - **Type 6 and 6P:** Submersible, protects against temporary or prolonged submersion in water.
- Hazardous Locations:
 - **Type 7:** For indoor use in Class I, Division 1, Groups A, B, C, and D hazardous locations.
 - **Type 9:** For indoor use in Class II, Division 1, Groups E, F, and G hazardous locations.

Key Requirements

- **Construction:** Enclosures must be constructed to withstand environmental conditions specific to their type. This includes materials, seals, and finishes that prevent ingress of dust, water, and other contaminants.
- **Testing:** Enclosures undergo rigorous testing to ensure they meet the specified protection levels. This includes tests for dust resistance, water ingress, corrosion resistance, and impact resistance.
- **Marking:** Each enclosure must be clearly marked with its NEMA type designation, manufacturer information, and any other relevant ratings or certifications.

Benefits of NEMA Enclosures

- **Safety:** Ensures that electrical components are protected from environmental hazards, reducing the risk of electrical failures and accidents.
- **Reliability:** Enhances the longevity and performance of electrical systems by providing robust protection.
- **Compliance:** Facilitates compliance with local regulations and standards, ensuring that products meet the necessary safety and performance criteria.

NOTE: Understanding these requirements is crucial for selecting the right enclosure for your application and ensuring compliance with NEMA standards

—
NEMA and UL – Ratings & Standards

Both NEMA and UL are important in ensuring the safety and reliability of electrical products, but they have some key differences. Here are the details of each:

	NEMA Self-Certification	UL Certification
Organization	National Electrical Manufacturers Association (NEMA).	Underwriters Laboratories (UL)
Scope	Primarily focuses on the performance and environmental ratings of electrical enclosures and equipment.	Focuses on safety standards for a wide range of products, including electrical components, appliances, and systems.
Testing	NEMA standards do not require third-party testing. Compliance is determined by the manufacturer, who self-certifies that their products meet NEMA standards.	UL certification requires third-party testing by qualified evaluators. Products must be tested and verified to meet UL standards. Additionally, UL conducts periodic audits of the manufacturing process to ensure ongoing compliance.
Standards	NEMA standards cover a wide range of electrical products, including motors, generators, and control panels. They specify construction, performance, and testing criteria to ensure safety and reliability.	UL standards are detailed and specific, often including rigorous safety tests. They cover aspects such as fire resistance, electrical shock protection, and mechanical hazards.

Key Differences

- Testing and Certification:
 - NEMA: Self-certified by the manufacturer. No third-party testing required.
 - UL: Requires third-party testing and periodic audits to ensure compliance.
- Focus:
 - NEMA: Emphasizes performance and environmental ratings.
 - UL: Emphasizes safety and compliance with detailed safety standards.

- Market Acceptance:
 - NEMA: Widely recognized in the U.S. for performance standards.
 - UL: Globally recognized for safety standards, often required for products to be sold in many markets.

— ABB NEMA full voltage power devices

For comprehensive information about our NEMA control products, we recommend taking a look at our detailed catalog. It contains detailed speci-

fications, technical data, and application examples that can assist you in selecting and using our products. You can find the catalog at the following link: [ABB NEMA full voltage power device - catalog](#).



— Building a Control Panel with NEMA and UL Components

When building your control panel, it is important to select components that adhere to NEMA and UL standards. This ensures they meet the necessary performance and safety standards. Design the control panel to accommodate these components, ensuring proper spacing, ventilation, and accessibility. Follow the guidelines provided by both organizations for installation and wiring.

Here are a few ABB products that have both NEMA and UL approval:

- **Tmax XT Circuit Breakers:**

- **Certifications:** UL 489 and NEMA AB 1
- These circuit breakers are designed for a wide range of applications, providing reliable protection for electrical systems. They are suitable for use in commercial and industrial environments.



- **Emax 2 Air Circuit Breakers:**

- **Certifications:** UL 1066 and NEMA AB 3
- These air circuit breakers offer advanced protection and control features, making them ideal for complex electrical systems in industrial settings.



- **AF Contactors:**

- **Certifications:** UL60947-4-1 and NEMA ICS 2
- The AF contactors are known for their high performance and reliability. They are used for controlling electric motors and other loads, ensuring safe and efficient operation ([LINK](#)).



- **NEMA 305 Contactors**

- **Certifications:** UL60947-4-1 and NEMA ICS 2
- NEMA 305 contactors provide high performance with flexibility and reliability, designed to match numerous applications. They are durable and easy to maintain with a large selection of accessories for easy configurator including; contacts, coils, and surge suppression.



- **PSTX Softstarters:**

- **Certifications:** UL60947-4-1 and NEMA ICS 2
- The PSTX softstarters provide smooth motor starting and stopping, reducing mechanical stress and extending the lifespan of equipment. They are suitable for various industrial applications.



- **ReliaGear® neXT-Panelboards:**

- **Certifications:** UL 67 and NEMA PB 1
- These panelboards are designed for low-voltage distribution, offering flexibility and reliability for electrical systems in commercial and industrial buildings ([LINK](#)).



These products are designed to meet stringent performance and safety standards, ensuring they are suitable for a wide range of applications.

After assembling the control panel, conduct thorough testing to ensure it operates correctly and safely. If required, submit the control panel for UL certification to verify that the entire assembly meets UL standard

NOTE: When building a control panel, it's important to ensure that all components meet the relevant standards and are properly integrated.

13. UL Coordination Ratings or UL Component Ratings

The terms “UL Coordination Ratings” and “UL Component Ratings” refer to different aspects of the certification and rating of electrical protective devices according to Underwriters Laboratories (UL) standards. Here are the exact differences between these two concepts:

UL Component Ratings:

- The “UL Component Rating” refers to the evaluation of individual electrical components used in electrical protective devices, such as circuit breakers.
- This rating concerns the performance and safety of the individual components about various electrical properties and requirements.
- One example is the short-circuit current rating (SCCR) of a circuit breaker, which indicates the short-circuit current up to which the circuit breaker can be operated safely.

UL Coordination Ratings:

- The “UL Coordination Rating” refers to the ability of different electrical protection devices to work together and form a coordinated protection system.

- Coordination evaluates how well different protective devices in the electrical system harmonize with each other to provide the best protection in the event of malfunctions or faults.
- This typically involves looking at different protective devices such as circuit breakers, circuit breakers, protective relays, etc., and coordinating their settings to ensure optimum performance of the overall system.
- Coordination is aimed at scheduling the operation of an individual device that trips so that only the affected device is switched off without affecting the entire circuit.

In simpler terms, “UL Component Ratings” refer to the individual rating of components, while “UL Coordination Ratings” focus on how different components work together in the system to ensure optimal performance and safety. It is important to consider both the individual component ratings and the coordinated actions in the overall system to ensure a reliable and safe electrical system.



Coordination ratings or component ratings are required in your control panel, depending on the load or application. An overview of ABB’s coordi-

nation and component ratings can be found in the SOC tool.

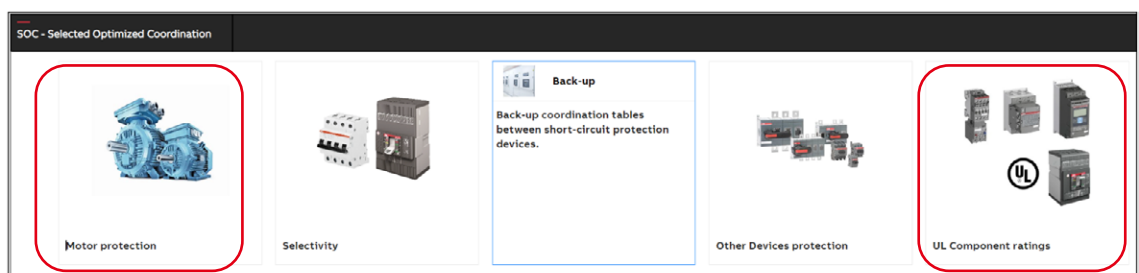

Coordination ratings can be found in the “Motor protection” selection on the left side, and “UL Component ratings” can be found on the right side.

14. Coordination with SOC

ABB's Selected Optimized Coordination tool (SOC) helps the user select the required protection against short-circuits and overloads. SOC includes many possible selection choices such as starter type, short-circuit level and overload characteristics, rated power and voltage, motor efficiency class, and so on. The coordination among devices cannot be determined directly. Tests in power laboratories shall be carried out to qualify the coordination type at low fault and high fault currents, according to UL or IEC standards. ABB's coordination tables are the results of such tests and represent ABB's offerings in terms of motor starting and protection, selectivity, backup, and switch-disconnector protection. Determining the Short-Circuit Current Rating of a complete elec-

trical panel can be very challenging, especially if proper considerations are not made during the initial stages of the component selection process. ABB's tested SCCRs can be accessed online through the SOC selection tool for combination motor controller and UL component ratings, providing comprehensive coordination tables to quickly select motor starter components over a wide range of HP ratings based on common global motor voltages (50/60 Hz) and SCCR fault levels.

Please be aware that SOC is constantly being enhanced to fully reflect all relevant aspects for the selection of UL motor starter coordination.

UL or IEC selection

UL Coordination type

Application values

Protection device

- Switch fuse
- Circuit Breaker
- Manual motor starter

Overload protection

- Without additional overload protection
- Thermal overload relays
- Electronic overload relays

The screenshot displays the 'SOC - Selected Optimized Coordination' interface. At the top, there are tabs for 'Motor protection', 'Selectivity', 'Back-up', 'Other Devices protection', and 'UL Component ratings'. Below these are several configuration sections: 'Standards' (IEC or ULCMC), 'Construction type' (Type A-F), 'Rated voltage' (120V-240V AC), 'Motor rated power' (1/2 hp to 2 hp), 'Current rating (FLA)' (0.13 A to 0.90 A), 'Rated short-circuit current' (18 kA to 35 kA), 'Protection device' (Switch fuse, Molded case circuit-breaker, Manual motor starter), and 'Overload protection' (Embedded, Thermal, Electronic). A 'Table status' section is also present.

Below the configuration sections, a table titled '259 Coordination tables found' lists four proposals:

Proposal #	Motor	Protection device	Contactor	Overload protection	Enclosure	Table
1	CMC, Type A, Protection device: Switch fuse; Overload protection: Thermal overload relay, 208 V AC (3-Ph), 100 kA (max)	Switch-Fuse Type: OS30FA1_ (30 A), OS30FACC_ (30 A); Fuse Class: I, CC; Current rating: 30 A	Type: AF09; Nema rating: 00; Size: 00; Full load current: 7.8 A	Type: TF42-31; Current rating: 2.3 - 3.1 A	Minimum volume: 2536 cu in; Status: Active; ID: 14609	14609
2	CMC, Type A, Protection device: Switch fuse; Overload protection: Thermal overload relay, 208 V AC (3-Ph), 100 kA (max), (NEMA Contactor Ratings)	Switch-Fuse Type: OS30FA1_ (30 A), OS30FACC_ (30 A); Fuse Class: I, CC; Current rating: 30 A	Type: AF09N00; Nema rating: 00; Size: 00; Full load current: 6.9 A	Type: TF42-31; Current rating: 2.3 - 3.1 A	Minimum volume: 1836 cu in; Status: Active; ID: 14610	14610
3	CMC, Type A, Protection device: Switch fuse; Overload protection: Electronic overload relay, 208 V AC (3-Ph), 100 kA (max)	Switch-Fuse Type: OS30FA1_ (30 A), OS30FACC_ (30 A); Fuse Class: I, CC; Current rating: 30 A	Type: AF09; Nema rating: 00; Size: 00; Full load current: 7.8 A	Type: EF19-27; Current rating: 0.8 - 2.7 A	Minimum volume: 1836 cu in; Status: Active; ID: 14611	14611
4	CMC, Type A, Protection device: Switch fuse; Overload protection: Electronic overload relay, 208 V AC (3-Ph), 100 kA (max), (NEMA Contactor Ratings)	Switch-Fuse Type: OS30FA1_ (30 A), OS30FACC_ (30 A); Fuse Class: I, CC; Current rating: 30 A	Type: AF09N00; Nema rating: 00; Size: 00; Full load current: 6.9 A	Type: EF19-27; Current rating: 0.8 - 2.7 A	Minimum volume: 1836 cu in; Status: Active; ID: 14612	14612

Coordination proposals as well alternatives

15. The Automation Panel

An example

Referenced enclosure and all components are compliant with UL standards. All included components are identified with CCN and file number.

Circuit breaker SU200
DIVQ - E212323

Relay socket CR-M
NRNT2 - E244330

Molded case circuit breaker Tmax XT
DIVQ - E93565

Switch disconnecter with fuse OS
WHTY - E101914

Motor circuit breaker MS
NKJH - E345003

Softstarter PSE
NMFT - E161428



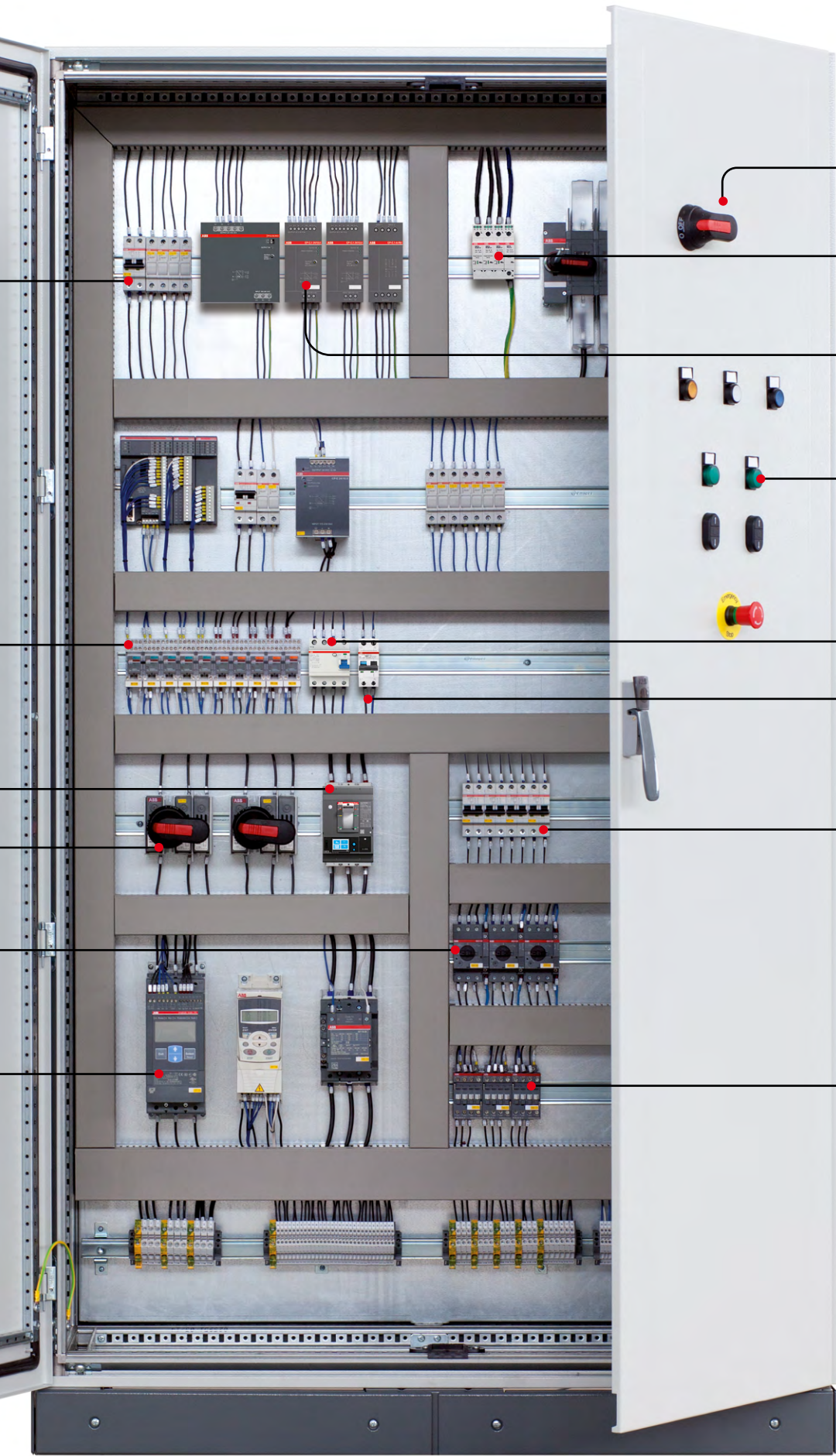

Switch disconnector OT
WHTY - E101914

Surge protection device OVR
VZCA2 - E322885

Power supplies
CP-S.1 24/40A
CP-C.1 24/10A
CP-C.1-A-RU

Control and signaling device M
NKCR - E76003

Residual current circuit breaker F200 A
KDAX2 - E244046

RCD DS201 UL
KDAX2 - E244046

Circuit breaker S200
QVNU2 - E76126

Contactor AF
NLDX7 - E312527

16. Quick search table

Component	ABB Product	UL Listed		UL Recognized		Ulc Listed		Ulc Recognized		Standard
		CCN	File no.	CCN	File no.	CCN	File no.	CCN	File no.	
Electronic timers	Electronic timers CT	NKCR	E140448							UL 508
Limit switch	Limit switch series Plastic (P), metallic (M) and accessories	NKCR	E191693			NKCR7	E191693			UL 508
Residual current circuit breaker	RCCBs			KDAX2	E244046			KDAX8	E244046	UL 1053, CSA C22.2 No. 144-06
	FI/LS (RCBOs)			KDAX2	E244046			KDAX8	E244046	UL 1053, UL 1077, CSA C22.2 No. 14, 144, 235
Installation contactors	ESB16...N, ESB20...N, ESB25...N, ESB40...N, ESB63...N, ESB100...N	NLDX	E191658			NLDX7	E191658			UL 60947-1, UL 60947-4-1, CAN/CSA-C22.2 No. 60947-1, CAN/CSA-C22.2 No. 60947-4-1
Mini contactors	Mini contactors	NLDX	E191658							UL 60947-1 UL 60497-4-1
				NLDX2	E191658			NLDX8	E191658	UL 60947-1 UL 60497-4-1
	Accessories for mini contactors			NKCR2	E48139			NKCR8	E48139	UL 508, UL 60947-5-1
	Accessories for mini contactors with low energy consumption	NKCR	E48139							UL 508, UL 60947-5-1
Accessories for mini contactors	Accessories for mini contactors			NKCR2	E48139			NKCR8	E48139	UL 508, UL 60947-5-1
		NLDX	E191658							UL 60947-1 UL 60947-4-1
		NKCR	E252354			NKCR7	E252354			UL 508 UL 60947-4-1
Compact switches	Compact power switch	DIVQ	E93565							UL 489, CSA C22.2 No. 5.1
	Compact power switches for motors			DKPU2	E93565					UL 489 e CSA C22.2 No. 5.1
Components and fieldbus plugs	Communication devices with fieldbus connector FBP	NRAQ	E179811			NRAQ7	E179811			UL 508
		NMFT	E161428			NMFT7	E161428			UL 508
Switch disconnectors	Switch disconnectors	WHTY	E229028			WHTY7	E101914			UL 98
		NRNT	E101914			NRNT7	E229028			UL 508
	Switch disconnectors with fuses	WHTY	E101914			WHTY7	E101914			UL 98
	Compact switch disconnectors	WJAZ	E116595							UL 489, CSA C22.2 No. 5.1
	Switch disconnectors for photovoltaics	WHVA	E354681			WHVA7	E354681			UL 98B
	Switch disconnectors for industrial applications			NRNT2	E229028					UL 508
	Auxiliary contacts for switch disconnectors		E83510			NKCR7	E83510			UL 508

Component	ABB Product	UL Listed		UL Recognized		Ulc Listed		Ulc Recognized		Standard
		CCN	File no.	CCN	File no.	CCN	File no.	CCN	File no.	
Motor protection switch	Combination motor controllers MS132, MO132, MS165, MO165	NKJH	E345003			NKJH7	E345003			UL 60947-1, UL 60947-4-1, (UL 508), CAN/CSA-C22.2 No. 60947-4-1, (CAN/CSA-C22.2 No. 14)
	Motor controllers, Manual MS116, MS132, MS132-T, MS165, MO165	NLRV	E137861			NLRV7	E137861			UL 60947-1, UL 60947-4-1, (UL 508), CAN/CSA-C22.2 No. 60947-4-1, (CAN/CSA-C22.2 No. 14)
Accessories for motor protection switches	Auxiliary contacts and auxiliary triggers	NLRV	E137861			NLRV7	E137861			UL 60947-1, UL 60947-4-1, (UL 508), CAN/CSA-C22.2 No. 60947-4-1, (CAN/CSA-C22.2 No. 14)
	Phase rails and feed-in terminals	NLRV	E121190			NLRV7	E121190			UL 60947-1, UL 60947-4-1, (UL 508), CAN/CSA-C22.2 No. 60947-4-1, (CAN/CSA-C22.2 No. 14)
Buffer modules	Buffer module CP-B	NMTR	E174460			NMTR7	E174460			UL 508A
Switched-mode power supplies and redundancy modules	Power supplies CP					QUZW7	E215666			UL 508
				NMTR2	E321314			NMTR8	E174460	UL 508
		NMTR	E174460	QQGQ2	E196145	NMTR7	E174460	QQGQ8	E134045	UL 508
				QQPX2	E317914			QQPX8	E317914	UL 60950, UL 60950-1
				EPBU2	E313203			EPBU8	E313203	UL 1310

Component	ABB Product	UL Listed		UL Recognized		Ulc Listed		Ulc Recognized		Standard		
		CCN	File no.	CCN	File no.	CCN	File no.	CCN	File no.			
Contactors and auxiliary contactors	3-pole contactors < 100 A	NLDX	E312527							UL 508 UL 60947-1 UL 60947-4-1		
						NLDX7	E312527			UL 60947-1 UL 60947-4-1		
								NILD8	E312527		CAN/CSA-C22.2 No. 14	
		3- and 4-pole contactors up to 75 A series A			NLDX2	E312527					UL 508	
	4-pole contactors AF Series	NRNT	E319322				NRNT7	E319322			UL 508 UL 60947-4-1	
						NRNT2	E319322		NRNT8	E319322	UL 508 UL 60947-4-1	
	3- and 4-pole contactors > 100 A	NLDX	E36588								UL 508 UL 60947-4-1	
		NRNT	E73397				NRNT7	E73397			UL 508 UL 60947-4-1	
							NLDX7	E36588			CAN/CSA-C22.2 No. 14	
		Special contactor EH							NLDX8	E36588	CAN/CSA-C22.2 No. 60947-1, CAN/CSA-C22.2 No.60947-4-1	
		Railway contactors (DC)			NLDX2	E36588					UL 60947-1 UL 60947-4-1	
		Auxiliary contactors and accessories	NKCR	E252354			NKCR7	E252354			UL 60947-1 UL 60947-4-1	
	Accessories for contactors and auxiliary contactors	Contactors AF and AS and auxiliary contactors	NLDX	E312527							UL 508 UL 60947-1 UL 60947-4-1	
						NLDX7	E312527			UL 60947-1 UL 60947-4-1		
NLDX			E36588							UL 508 UL 60947-4-1		
				NLDX2	E312527					UL 508		
								NLDX8	E312527		CAN/CSA-C22.2 No.14	
				NKCR2	E252354						UL 508 UL 60947-5-1	
				NKCR2	E252354						UL 508 UL 60947-5-1	
				NKCR2	E76003						UL 508 UL 60947-5-1	
				NLDX	E312527						UL 508 UL 60947-1 UL 60947-4-1	
				NKCR	E252354			NKCR7	E252354		UL 508	
						NKCR2	E191693			NKCR8	E191693	UL 508
				NKCR	E252354			NKCR7	E252354		UL 508 UL 60947-5-1	
				NKCR	E76003			NKCR7	E76003		UL 508	
						NKCR2	E252354				UL 508 UL 60947-5-1	
Circuit breakers and accessories	Circuit breakers	DIVQ	E212323			DIVQ7	E212323			UL 489, CSA C22.2 No.5		
		DIVQ	E312425			DIVQ7	E312425			UL 489, CSA C22.2 No.5		
				QVNU2	E76126			QVNU8	E76126		UL 1077	
				QVNU2	E76126			QVNU8	E76126		UL 1077, CSA C22.2 No.235	
				QVNU2	E76126						UL 1077, CSA C22.2 No.235	

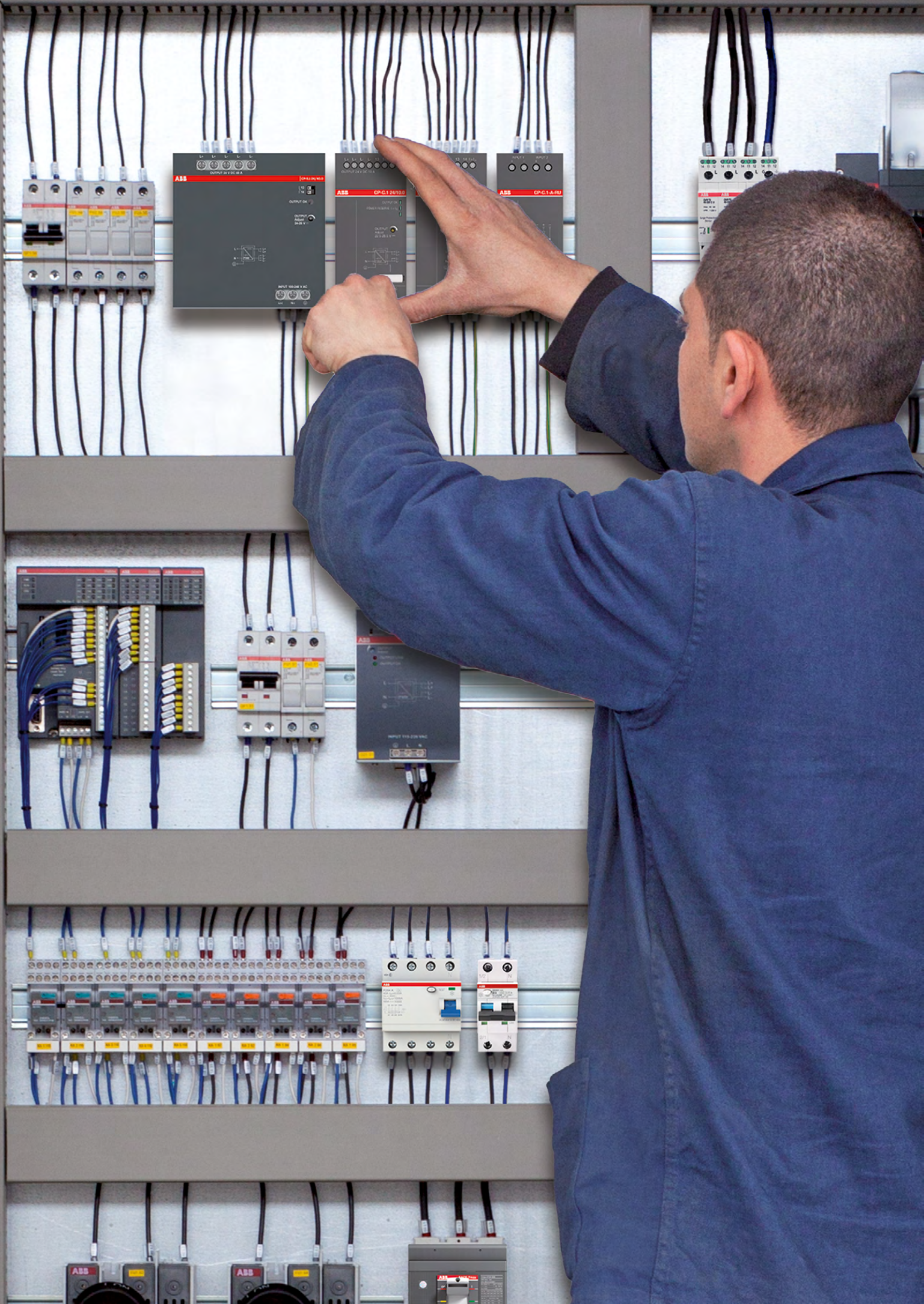

17. Components

Sorted by CCN numbers

DIHS Circuit Breaker Accessories

This category includes accessories for automatic safety devices and high-performance circuit breakers. These include: undervoltage trips, working current trips, locking devices, rotary handles, axial extensions, busbars, remote switches, auxiliary switches, and signal contacts designed

for "field installation" and as circuit breakers as well as for mounting on approved equipment.

The instructions for the proper combination of circuit breakers and accessories are shown on the product.

Products of the categories DIHS and DIHS7

Component	ABB Product	UL Listed		ULc Listed		Standard
		CCN	File no.	CCN	File no.	
Accessories for circuit breakers	Undervoltage release for S800: S800-UVR Accessories for S800: S800-RT2125, S800-IP9, S800U-PLL, S800-RHE-H, S800-RHE-EM, S800-RHE-S, S800-RD, S800W-RSU Auxiliary switches/signal contacts for S800: S800 AUX, S800 AUX/ALT Working current trip for S800: S800-SOR	DIHS	E257901	DIHS7	E257901	UL 489, CSA 22.2 No.5
	Accessories for S200 UDC, SU200 M, SU200 MR: Auxiliary switches/signal contacts S2C-S6RU and S2C-H6RU, working current actuator S2C-AxU	DIHS	E250145			UL 489, CSA 22.2 No.5

Products in category DIHS2

Component	ABB Product	UL Recognized		ULc Recognized		Standard
		CCN	File no.	CCN	File no.	
Accessories for circuit breakers	Accessories for SU200 M: Busbars PS 1/6/16 BP, PS 1/12/16 BP, PS 1/18/16 BP, PS 2/6/16 BP, PS 2/12/16 BP, PS 2/18/16 BP, PS 3/6/16 BP, PS 3/12/16 BP, PS 3/18/16 BP, Terminal covers, Busbar clamps	DIHS2	E321314			UL 489

Condition

These products may only be used if they meet the following conditions:

- In combination with SU200 M (CCN DIVQ)
- Busbars with the same pole position can be combined a maximum of three times
- The busbar system is valid for SU200 M (CCN DIVQ) when mounted in a control cabinet with the minimum dimensions of 45.72 x 45.72 x 63.50.

DIUR Circuit Breakers, Molded Case and Circuit-Breaker Enclosures for Use in Photovoltaic Systems

This category includes high-performance circuit breakers for overcurrent protection and with disconnect properties in direct current photovoltaic (PV) systems by Article 690 of ANSI/NFPA 70 "National Electrical Code".

These circuit breakers are intended for use with certified housings or as part of other certified parts. PV fuse machines can be used up to 1500 V DC and, unless otherwise indicated, must not exceed 80% of the nominal current. They are also designed for ambient temperatures from -20 to 50 °C.

Products in the category DIUR

Component	ABB Product	UL Listed		ULc Listed		Standard
		CCN	File no.	CCN	File no.	
Circuit breaker for photovoltaic applications	S804U-PVS	DIUR	E351137			UL 489B

DIVQ Circuit Breakers, Molded Case and Circuit-Breaker Enclosures

This category includes molded case circuit breakers and circuit breakers. They are designed to provide a main, distributor, and or service-entrance, feeder, or branch-circuit protection by ANSI/NFPA 70 (NEC).

DIVQ7 covers all products that are compliant with "Canadian Electrical Code, Part I" (CEC) CAN/ CSA-C22.1.

Products of the categories DIVQ and DIVQ7

Component	ABB product	UL Listed		ULc Listed		Standard
		CCN	File no.	CCN	File no.	
Molded case circuit breakers	Tmax XT	DIVQ	E93565			UL 489, CSA 22.2 No. 5.1
Circuit breakers	SU200 M, SU200 MR, S200 UDC	DIVQ	E212323	DIVQ7	E212323	UL 489, CSA 22.2 No.5
	S800U	DIVQ	E312425	DIVQ7	E312425	UL 489, CSA 22.2 No. 5.2

DKPU2 Circuit Breakers, Adjustable Instantaneous Trip Type – Component

Devices belonging to this category can be used to protect 3-phase asynchronous motors. They are needed to protect the engine against any problems that may arise from the moment it is switched on.

Products in category DKPU2

Component	ABB product	UL Recognized		ULc Recognized		Standard
		CCN	File no.	CCN	File no.	
Molded case circuit breakers for motors	Tmax XT: Motor Control Protection Circuit Breaker - MCP	DKPU2	E93565			UL 489 CSA C22.2 No. 5.1

Operating conditions

- These devices must be evaluated according to the "Combination Motor Controller" certificate.
- They are intended for use with overcurrent protection devices for motor or branch switching.
- If the circuit and the load terminals are suitable for field wiring.
- These devices are suitable for use on the load side as well as on the feed side. The wiring can therefore be done on the upper or lower terminals.

DKSY Circuit Breakers, Series Connected – Component

The category refers to a certified combination of circuit breakers in series. This combination has a common short-term rating.

Products in the category DKSY

Main Breaker			Branch Breaker			Interruption Rating		
Typ	Amps	Pole	Typ	Amps	Pole	Rms Sym. A	V AC	Phase
XT4H	250	3 or 4	SU401M	2-32	1	42 kA	240	1
XT4S	250	3 or 4	SU401M	2-32	1	35 kA	240	1
XT4N	250	3 or 4	SU401M	2-32	1	25 A	240	1
XT4H	250	3 or 4	SUP401M	30	1	30 kA	480 Y/277 V	1
XT4S	250	3 or 4	SUP401M	30	1	30 kA	480 Y/277 V	1
XT4N	250	3 or 4	SUP401M	30	1	25 kA	480 Y/277 V	1
XT4H	250	3 or 4	SUP403M	30	3	50 kA	480 Y/277 V	3
XT4S	250	3 or 4	SUP403M	30	3	35 kA	480 Y/277 V	3
XT4N	250	3 or 4	SUP403M	30	3	25 kA	480 Y/277 V	3

Main Device			Branch Breaker			Interruption Rating RMS		
Typ	Amps	Pole	Typ	Amps	Pole	Amps	V AC	Phase
XT3	100-225	3, 4	S800U	25-100	1	35,000	240	1
XT3	100-225	3, 4	S800U	25-100	2, 3, 4	50,000	240	3
XT4	60-250	3, 4	S800U	25-100	1	35,000	240	1
XT4	60-250	3, 4	S800U	25-100	2, 3, 4	50,000	240	3

Main Breaker			Main Fuse			Interruption Rating		
Typ	Amps	Anz. Pole	Typ	Max Amps	V	Amps	V	Phase
S800U	10-100	1	J	250	600	30,000	240	1
S800U	10-100	2, 3, 4	J	250	600	50,000	240	3

EPBU Direct-plug-in and Cord-connected Class 2 Power Units

This category includes Class 2 power supplies and chargers for indoor and outdoor use. They are intended for use in AC branch circuits up to a maximum of 150 V. These devices use a protective insulated transformer and integrated components to generate alternating or direct current. They are only tested for general use unless otherwise indicated. Each output complies with protection class 2 voltage, current, and volt-ampere limits according to ANSI/NFPA 70 (National Electrical Code).

The maximum output voltage is 42.4 V for AC and 60 V for DC. Protection class 2 power supplies are equipped with back feed protected (BFP) or equivalent integrated protection to inhibit the feedback of the current in the event of a fault. The following product identifiers may appear on the product:

- "Class 2 Battery Charger"
- "Class 2 Power Supply"
- "Class 2 Power Unit"
- "Class 2 Transformer"

Products of categories EPBU2 and EPBU8

Component	ABB product	UL Recognized		ULc Recognized		Standard
		CCN	File no.	CCN	File no.	
Power supplies	Power supplies CP-E, CP-D, CP-T, CP-S, CP-C	EPBU2	E313203	EPBU8	E313203	UL 1310

IZLT Fuseholder, Cartridge Fuses

Products of the categories IZLT and IZLT7

Komponente	ABB product	UL Listed		ULc Listed		Standard
		CCN	File no.	CCN	File no.	
Fuse holder	E90 CC	IZLT	E327750	IZLT7	E327750	UL 4248-1, UL 4248-4
Fuse holder	E90 J	IZLT	E327750	IZLT7	E327750	UL 4248-1, UL 4248-8

Products of the categories IZLT2 and IZLT8

Component	ABB product	UL Listed		ULc Listed		Standard
		CCN	File no.	CCN	File no.	
Fuse holder	E90/32	IZLT2	E327750	IZLT8	E327750	UL 4248-1
Fuse holder	E90/50	IZLT2	E327750	IZLT8	E327750	UL 4248-1
Fuse holder	E90/125	IZLT2	E327750	IZLT8	E327750	UL 4248-1

IZMR Fuseholder, Photovoltaics

Products in category IZMR

Component	ABB product	UL listed		ULc listed		Standard
		CCN	File no.	CCN	File no.	
Fuse holder	E90 PV	IZMR	E345878			UL 4248-18

KDAX Ground-fault Sensing and Relaying Equipment

This category includes residual current circuit breakers (RCCB) and RCBOs.

Please note that the UL standards refer to ground fault current detection devices as well as ground fault current detection devices in combination with tripping devices, i.e. RCBOs or RCCBs.

The associated standard for these products is ANSI/UL 1053 "Ground-fault Sensing and Relaying Equipment" and UL 1077 "Standard for Supplementary Protectors for Use in Electrical Equipment".

Products of the categories KDAX2 und KDAX8

Component	ABB product	UL Recognized		ULc Recognized		Standard
		CCN	File no.	CCN	File no.	
Leakage current-Protective devices (RCDs)	RCCBs: F200 Type A (up to 100 A)	KDAX2	E244046	KDAX8	E244046	UL 1053, CSA C22.2 No. 144-06
	RCBOs DS201UL Type A	KDAX2	E244046	KDAX8	E244046	UL 1053, UL 1077, CSA C22.2 No. 14, 144, 235

Operating conditions for F200 Type A up to 100 A

- The products are mounted on DIN rails and installed in the control cabinet.
- The clamps are not suitable for field routing
- They are not suitable for device/line protection of electrical circuits, as they do not require LS (MCB).
- Their resistance to short-circuits has been tested in conjunction with a backup fuse of max. 100 A up to currents of 100 A.
- Ambient temperature (with daily average) $\leq +35\text{ °C}$ -25 °C ... $+55\text{ °C}$

Operating conditions of use for DS201UL Type A

- They must be mounted on the DIN rail and installed in the control cabinet.
- Must protect using a fuse with a rated current equal to or less than the device to provide interruption for short-circuit currents up to 6,000 A (effective value)
- Ambient temperature (with daily average) $\leq +35\text{ °C}$ / $\leq 95\text{ °F}$ -25 °C ... $+55\text{ °C}$ / -13 °F ... $+131\text{ °F}$
- The residual current non-tripping threshold is set to 50% of the sinusoidal nominal residual current.

NKCR (Motor Controllers) Auxiliary Devices

The devices belonging to this category are intended for use in control circuits:

- Electromagnetic switches (relays)
- Manually operated switches (pushbuttons, key-operated switches)
- Indicator lights
- Controls (including indicator lights and selector switches)
- Thermal, Electronic and Magnetic Overload Relays
- Timing relay
- Foot-operated switches
- Flow Switches
- Level controller

Products of the categories NKCR und NKCR7

Component	ABB product	UL Listed		ULc Listed		Standard
		CCN	File no.	CCN	File no.	
Contactors and auxiliary contactors	Small auxiliary contactors series K6, KC6 Auxiliary relays NF, NL, TNL	NKCR	E252354	NKCR7	E252354	UL 508, UL 60947-4-1
Accessories for contactors and auxiliary contactors	Timer relay for front-mounted mounting TP-40D, TEF3, TEF4 e TEF5	NKCR	E252354	NKCR7	E252354	UL 508
	Auxiliary contacts CA, CAL, CA5/CC5, CA4, CAL, CAT, CB5, CA3, BA4, BX4, BX4-CA A. Interlocks VE/VM	NKCR	E252354	NKCR7	E252354	UL 508, UL 60947-5-1
	Auxiliary contacts for contactors A e AF > 100 A	NKCR	E76003	NKCR7	E76003	UL 508
Command devices	Pushbutton series M: MP, MPD, MPM, KP6, MPE, M2SS, M3SS, M2SSK, M3SSK, MT, KPR, ML, MJS Pushbuttons Series C: CP, C2SS, C3SS, CE, CPM, CB, CL	NKCR	E76003	NKCR7	E76003	UL 508, UL 60947-5-1
Limit switch	Limit Switches Series P, M, Accessories	NKCR	E191693	NKCR7	E191693	UL 508
Switch disconnectors	Auxiliary contacts for shooters: OA_, OBEA_, OBFZ_	NKCR	E83510	NKCR7	E83510	UL 508
Mini contactors	Small auxiliary contactors series K6, KC6	NKCR	E48139			UL 508, UL 60947-5-1
Accessories for mini contactors	Auxiliary contacts CA6/CAF6	NKCR	E252354	NKCR7	E252354	UL 508, UL 60947-4-1
Measuring and monitoring relays	Monitoring relays CM-E, CM-N, CM-S	NKCR	E140448	NKCR7	E149922 E140448	UL 508
Thermal overload relays	Thermal relays T16, TA25DU, TA40DU, TF42, TA75, TA80, TF65, TF96, TF140DU 90, TF140DU 110, TF140DU, TF140DU, TA200, A450	NKCR	E48139	NKCR7	E48139	UL 508, UL 60947-4-1
	Electronic relays E16, EF19, EF45, EF65, EF96, E140, E200, E320, E500, E800, EF146, EF460, EF750. UMC100 and auxiliary modules DX111, DX122, voltage module VI150, VI155	NKCR	E48139	NKCR7	E48139	UL 508, UL 60947-4-1
Accessories for thermal relays	Mounting kit: DB16, DB42, DB140E, DB145E, DB16E, DB45E, DB80E, DB19EF	NKCR	E48139	NKCR7	E48139	UL 508
Accessories for motor protection	HK4, UA4 e AA4, CK, HK und SK	NKCR	E149922	NKCR7	E149922	UL 508
Electronic timers	Electronic timers CT-E, CT-S, CT-D	NKCR	E140448			UL 508

Some indicator lights and pushbutton assemblies are made up of individual modular components such as lamps, sockets, and contact elements and are individually certified. These parts are intended for use in control circuits of motor applications and similar devices.

The contact and switching outputs are marked with a code A600 or A800 with the rated voltage, regardless of whether they are normal or heavy duty (standard duty or heavy duty). These codes indicate the control circuit load that can be controlled by this device. The mea

Rating codes for AC control contacts at 50 and 60 Hz

Rating	Thermal endurance test current A	Maximum current (A)								VA max	
		120 V		240 V		480 V		600 V		Power	Sleep
		Power	Sleep	Power	Sleep	Power	Sleep	Power	Sleep		
A150	10.0	60	6.00	–	–	–	–	–	–	7200	720
A300	10.0	60	6.00	30	3.00	–	–	–	–	7200	720
A600	10.0	60	6.00	30	3.00	15	1.50	12	1.20	7200	720
B150	5.0	30	3.00	–	–	–	–	–	–	3600	360
B300	5.0	30	3.00	15	1.50	–	–	–	–	3600	360
B600	5.0	30	3.00	15	1.50	7.5	0.75	6	0.60	3600	360
C150	2.5	15	1.50	–	–	–	–	–	–	1800	180
C300	2.5	15	1.50	7.50	0.75	–	–	–	–	1800	180
C600	2.5	15	1.50	7.50	0.75	3.75	0.375	3	0.30	1800	180
D150	1.0	3.60	0.60	–	–	–	–	–	–	432	72
D300	1.0	3.60	0.60	1.80	0.30	–	–	–	–	432	72
E150	0.5	1.80	0.30	–	–	–	–	–	–	216	36

These auxiliary devices have not been studied for machines with restrictive access or specially defined areas. Such auxiliary equipment is tested according to ANSI/UL 294 "Access Control System Units".

Rating codes for AC control contacts at 50 and 60 Hz

Rating	Thermal endurance test current	Maximum current (A)			Maximum or minimum breaking capacity up to 300 V
		125 V	250 V	301 up to 600 V	
N150	10	2.2	–	–	275
N300	10	2.2	1.1	–	275
N600	10	2.2	1.1	0.40	275
P150	5.0	1.1	–	–	138
P300	5.0	1.1	0.55	–	138
P600	5.0	1.1	0.55	0.20	138
Q150	2.5	0.55	–	–	69
Q300	2.5	0.55	0.27	–	69
Q600	2.5	0.55	0.27	0.10	69
R150	1.0	0.22	–	–	28
R300	1.0	0.22	0.11	–	28

Products of the categories NKCR2 and NKCR8

Component	ABB product	UL Recognized		ULc Recognized		Standard
		CCN	File no.	CCN	File no.	
Accessories for contactors and auxiliary contactors	Mechanical locking device WB75	NKCR2	E252354			UL 508, UL 60947-5-1
	Auxiliary contact CA5	NKCR2	E252354			UL 508, UL 60947-5-1
	Auxiliary contact CAL18-11RT	NKCR2	E76003			UL 508, UL 60947-5-1
	Electronic timers TE5L-24, -120, -240, TE5S-24, -120, -240, -440	NKCR2	E191693	NKCR8	E191693	UL 508
	Block contactors VE5-2, VE-1+, VM5-1	NKCR2	E252354			UL 508, UL 60947-5-1
Mini contactors	K6 or KC6 für 40E, 31Z or 22Z	NKCR2	E48139	NKCR8	E48139	UL 508, UL 60947-5-1
Accessories for mini contactors	Auxiliary contacts with 11K, 11E, 11M or 11N	NKCR2	E48139	NKCR8	E48139	UL 508, UL 60947-5-1
Switches, buttons, and indicator lights for mounting on the DIN rail	Switch E211 and E211X	NKCR2	E171252	NKCR8	E171252	UL 508
	Switch E213					
	Group switch E214					
	Pushbutton E215					
	Illuminated Pushbutton E217					
	Control switch E218					
	Indicator light E219					
Dummy housing E210-DH						

NKJH Combination Motor Controllers

This category includes combination motor controllers, which ensure motor protection and control functions through motor controllers, circuit breakers, short-circuit and earth fault protection, and motor overload protection. The functions can be combined in a controller unit or consist of individual components. These products are labeled "Combination Motor Controller" to indicate that all motor protection and control functions are taken into account.

A combination motor controller is intended for factory installation in a control cabinet, in an industrial control cabinet, or for field installation in an enclosure for industrial control tasks. The combination motor controllers are marked with a short-circuit value and are intended for circuits in which the possible residual current does not exceed the specified short-circuit value.

Products of the categories NKJH and NKJH7

Component	ABB product	UL Listed		ULc Listed		Standard
		CCN	File no.	CCN	File no.	
Motor-circuit breaker	MS132, MO132, MS165, MO165	NKJH	E345003	NKJH7	E345003	UL 60947-1, UL 60947-4-1, (UL 508), CAN/CSA-C22.2 No. 60947-4-1, (CAN/CSA-C22.2 No. 14)

NLDX Motor Controllers, Magnetic

This category includes:

- Combined starter and speed controller
- Transformer starter and star-delta starter combinations
- Governor

The magnetic motor controllers have been tested by our accredited laboratories for approval in continuous operation and under the specified rated load.

Products of the categories NLDX and NLDX7

Component	ABB product	UL Listed	File no.	ULc Listed	File no.	Standard
		CCN		CCN		
Contactors and auxiliary contactors	Contactors A/AL 09 A75 3/4 Pole, AF09 96 3/4 poles, AS/ASL 09... 16, UA26... 40	NLDX	E312527			UL 508, UL 60947-1, UL 60947-4-1
	Sagittarius AF09... AF96, AS/ASL 09... 16			NLDX7	E312527	UL 60947-1, UL 60947-4-1
	Contactor A/AF95.. AF1650, Contactor AM95 AM 300	NLDX	E36588			UL 508, UL 60947-4-1
	Contactors and accessories A/AF/AE >100 A, contactors EK and accessories > 100 A, contactors and accessories EH >100 A			NLDX7	E36588	CAN/CSA-C22.2 No. 14
Accessories for contactors and auxiliary contactors	Connection Set BEA16-4, BEA26-4, BEA38-4, BER16-4, BER38-4, BEY16-4, BEY38-4, LY16-4, LY38-4, BEA16-3, BER16C-3, BEY16C-3, VM-3	NLDX	E312527			UL 508, UL 60947-1, UL 60947-4-1
	Connection set BEA, BER, BEY, LY, VM, LF, LG, LD and LH			NLDX7	E312527	UL 60947-1, UL 60947-4-1
	BEA, BEM, BED, LP, LX, LW, LK, LD, LY, VM, LT, CAL19, CEL19-10	NLDX	E36588			UL 508, UL 60947-4-1
	Surge protection: RT, RC	NLDX	E312527			UL 508, UL 60947-1, UL 60947-4-1
Installation contactors	ESB16...N, ESB20...N, ESB25...N, ESB40...N, ESB63...N, ESB100...N	NLDX	E191658	NLDX7	E191658	UL 60947-1, UL 60947-4-1, CAN/CSA-C22.2 No. 60947-1, CAN/CSA-C22.2 No. 60947-4-1
Mini contactors	B6, VB6, VB6A, B7, B7D, B7W, BC7W, VB7, VB7A, VB7D, BC6, VBC6A, VBC6, BC7, VBC7 or VBC7A, B6S, VB6S, VB6SA, B7S, VB7S or VB7SA	NLDX	E191658			UL 60947-1, UL 60947-4-1
Accessories for mni contactors	VARISTOR extinguisher RV-BC6	NLDX	E191658			UL 60947-1, UL 60947-4-1

Products of the categories NLDX2 and NLDX8

Component	ABB product	UL Recognized		ULc Recognized		Standard
		CCN	File no.	CCN	File no.	
Contactors and auxiliary contactors	Contactors AF09... AF38			NLDX8	E312527	CAN/CSA-C22.2 No. 14
	Contactors up to 75 A: A/AL 09 A75 3/4 Pole, UA26... 40	NLDX2	E312527			UL 508
	Contactors EHDB130, EHDB220, EHDB280, EHDB360, EHDB520, EHDB650, EHDB800, EHDB960			NLDX8	E36588	CAN/CSA-C22.2 No. 60947-1, CAN/CSA-C22.2 No. 60947-4-1
	Contactors EHD110 EHD960, EHDB130 EHDE960 and AF110B-30-00RT.... AF300B-30-22R	NLDX2	E36588			UL 60947-1, UL 60947-4-1
Accessories for contactors and auxiliary contactors	Accessories for contactors: busbars BEA, BER	NLDX2	E312527			UL 508
	Accessories for contactors: busbars BEA, BER			NLDX8	E312527	CAN/CSA-C22.2 No. 14
Mini contactors	B6, B6S, B7, B7S, B7W, BC6, BC7, BC7W, VB6, VB6A, VB6S, VB7, VB7A, VB7S, VBC6, VBC6A, VBC7, VBC7A	NLDX2	E191658	NLDX8	E191658	UL 60947-1, UL 60947-4-1

NLRV Motor Controllers, Manual

This category includes the following manually switchable devices that are intended for the direct start of a motor:

- Direct Starter
- Transformer start
- Combined starters and speed controllers
- Tempering resistance
- Governor

Motor circuit breakers and switch disconnectors that have also been tested for use as isolators are labeled "Suitable as Motor Disconnect".

These devices are certified in accordance with Section 430.109(A)(6) of ANSI/NFPA 70 The National Electrical Code (NEC) was intended to be installed on the load side of the motor protection circuit.

Products of the categories NLRV and NLRV7

Component	ABB product	UL Listed		ULc Listed		Standard
		CCN	File no.	CCN	File no.	
Switch disconnectors	Switch disconnector OT (16 A... 80 A) and Included Switches EOT	NLRV	E63822	NLRV7	E63822	UL 508
	Switch disconnectors OTM-063, OTM-080, OTM-125	NLRV	E167205	NLRV7	E167205	UL 508
	Switch disconnector OT for motors	NLRV	E63822	NLRV7		UL 508
Motor protection switch	MS116 (with accessories SA1), MO132, MS132, MO165, MS165	NLRV	E137861	NLRV7	E137861	UL 60947-1, UL 60947-4-1, (UL 508), CAN/CSA-C22.2 No. 60947-4-1, (CAN/CSA-C22.2 No. 14)
Accessories for motor protection switches	TS1-M3-S1, TS1-M3-S2, TS1-M3-K	NLRV	E345003	NLRV7	E345003	UL 60947-1, UL 60947-4-1, (UL 508),
	HKF1, HK1, SK1, CK1, UA1, AA1, IB132, DMS132	NLRV	E137861	NLRV7	E137861	(UL 508),
	PS1, PS2 S1-M1-xx, S1-M2-xx, S1-M3-xx, S2-M3-xx	NLRV	E121190	NLRV7	E121190	CAN/CSA-C22.2 No. 60947-4-1, (CAN/CSA-C22.2 No. 14)

Products in category NLRV2

Component	ABB product	UL Recognized		ULc Recognized		Standard
		CCN	File no.	CCN	File no.	
Accessories for motor protection switches	Handles for MMS MSHD-LB, MSH-LB, MSHD-LTB, MSHD-LY, MSH-LY, MSHD-LTY	NLRV2	E167205			UL 60947-1, UL 60947-4-1, (UL 508), CAN/CSA-C22.2 No. 60947-4-1, (CAN/CSA-C22.2 No. 14)
Accessories for switch disconnectors	Handles for switch disconnectors	NLRV2	E63822			UL 508

Conditions

They must have the same degree of protection as the corresponding control cabinets (NEMA TYPE).

NMFT Motor Controllers, Mechanically Operated and Solid-state

This category includes the following devices for direct engine starting:

- Soft starter
- Semiconductor starter
- Voltage-reducing semiconductor starters
- Semiconductor speed controller

These devices are designed for direct control of motors.

One of the following labels will appear on the product:

- “Ind. Cont. Eq.”
- “Industrial Control Equipment”
- “Solid-state Motor Controller”
- “Solid-state Reduced-voltage Starter”

Additional information on protection against short-circuits is shown on the product.

Products of the categories NMFT and NMFT7

Component	ABB product	UL Listed		ULc Listed		Standard
		CCN	File no.	CCN	File no.	
Components and fieldbus connectors	Communication modules and accessories FBP: PDP, PDQ, PDX, PDF, PDM, PDV, PDA, CDA, CDP, DNP, COP, MRP, DNF, DNM, DNX, DNC, DNR	NMFT	E161428	NMFT7	E161428	UL 508
Soft starters and accessories	Two-phase controlled soft starter: PSR(C) 3... 105, PSR-FAN, PSR30-M132 Three-phase controlled soft starter: PSE18... PSE370, PSTX30... PSTX1250, PSTX HMI, PS-FBPA, PSEEK	NMFT	E161428	NMFT7	E161428	UL508, CAN/CSA-C22.2 No. 14-10, CAN/CSA-C22.2 No. 14-13, CAN/CSA-C22.2 No. 142-M1987

NMTR Power Circuit and Motor-mounted Apparatus

This category includes:

- Autotransformers
- Lamp dimmers
- Incandescent lamps
- Mercury vapour lamps
- Surgical lights
- Phase converters current compensation devices
- Power supplies for industrial use
- Current transformers and transmitters
- Voltage transformers and transmitters

Products of the categories NMTR and NMTR7

Component	ABB product	UL Listed		ULc Listed		Standard
		CCN	File no.	CCN	File no.	
Switched-mode power supplies and redundancy modules	Power supplies CP-E, CP-D, CP-T, CP-S, CP-C	NMTR	E174460	NMTR7	E174460	UL 508
Buffer modules	Buffer modules CP-B	NMTR	E174460	NMTR7	E174460	UL 508
Signal towers and lamps	Signal towers K70 signal lights KSB Accessories: KA, KB, KS, KT	NMTR	E175441	NMTR7	E175441	UL Tipo 5
Smisline TP Plug-in socket	ZLS200, ZLS906, ZLS908, ZLS920, ZLS926, ZLS928	NMTR	E222110	NMTR7	E222110	UL508
Smisline TP accessories	Power supply blocks ZLS924..., ZLS250, ZLS251, ZLS252, ZLS253, Busbars ZLS201E..., Busbars ZLS, Adapter ZLS970..., ZLS971..., ZLS972..., ZLS973..., Combination module and adapter for MS ZMS132..., ZMS93x...	NMTR	E222110	NMTR7	E222110	UL508
Current measurement system CMS	Control units CMS-700 Sensors CMS-10x, CMS-12x, CMS-20x Cable CMS-80x Connector CMS-820	NMTR	E222110			UL 508 CSA C22.2 No. 14

Products of the categories NMTR2 and NMTR8

Component	ABB product	UL Recognized		ULc Recognized		Standard
		CCN	File no.	CCN	File no.	
Switched-mode power supplies and redundancy modules	CP-A RU power supplies and CP-A CM Control modules	NMTR2	E321314	NMTR8	E174460	UL 508
Accessories for motor protection switches	Terminals PS, PS-END	NMTR2	E321314			UL 508
Signal towers and lamps	Bulb KA4	NMTR2	E175441	NMTR8	E175441	UL 508

Conditions

- They may only be used within a control cabinet.
- They may only be operated with their rated values.

NRAQ [Industrial Control Equipment] Programmable Controllers

This category includes programmable industrial control systems that use programmable memory to internally store application-oriented instructions for specific functions. Such functions refer to the logic, sequence control, counting, and control of various industrial devices through digital or analog outputs. This category also includes power supplies, central computing units, input and output devices, computer interfaces, and programming or program diagnostic units with associated programmable control systems.

All products that fall into this category are labeled with their electrical characteristics.

One of the following markings is displayed on the product:

- “Ind. Cont. Eq.”
- “Industrial Control Equipment”
- “Prog. Cntrlr.”
- “Programmable Controller”

This category does not include equipment for use in applications where devices for measuring, recording, and/or controlling process variables (such as temperature, pressure, and flow) and auxiliary devices for these devices such as sensors, transmitters, and valves can be found. In addition, this category does not include programmable control units for use in safety-relevant functions (functional safety applications).

Products of the categories NRAQ and NRAQ7

Component	ABB product	UL Listed		ULc Listed		Standard
		CCN	File no.	CCN	File no.	
Components and fieldbus connectors	Communication Modules and Accessories FBP: PDP, PDQ, PDX, PDF, PDM, PDV, PDA, CDA, CDP, DNP, COP, MRP, DNF, DNM, DNX, DNC, DNR	NRAQ	E179811	NRAQ7	E179811	UL 508

NRNT [Industrial Control Equipment] Switches, Industrial Control

This category includes:

- Magnetically actuated switches (e.g. contactors)
- Manually operated switches
- Photoelectric relays
- Semiconductor relays

These devices are not intended for controlling the rated motor load.

One of the following product identifiers appears on the product:

- “Ind. Cont. Eq.”
- “Ind. Cont. Switch”
- “Industrial Control Equipment”
- “Industrial Control Switch”

Switches for direct control of motors are labeled with performance specifications and fall under the category of magnetic motor controllers (NLDX), manual motor controllers (NLRV), and mechanically actuated, semiconductor motor controllers (NMFT).

Products of the categories NRNT and NRNT7

Component	ABB product	UL Listed		ULc Listed		Standard
		CCN	File no.	CCN	File no.	
Contactors and auxiliary contactor	Contactors AF09... 38, 4-pole	NRNT	E319322	NRNT7	E319322	UL 508, UL 60947-4-1
	Contactors GAF145... 750/AF1250, AF2050	NRNT	E73397	NRNT7	E73397	UL 508, UL 60947-4-1
Switch disconnectors	Switch disconnectors OT32ED9N2, OT40FD9N2, OT63ED8, OT80FD8, OT100ED8, OT100FD8	NRNT	E229028	NRNT7	E229028	UL 508

Products of the categories NRNT2 and NRNT8

Component	ABB product	UL Recognized		ULc Recognized		Standard
		CCN	File no.	CCN	File no.	
Contactors and auxiliary contactors	Contactors AF09... 38, 4-pole	NRNT2	E319322	NRNT8	E319322	UL 508, UL 60947-4-1
Switch disconnectors	Disconnecter Cat. No. OESC, followed by 250K or 500K, followed by 3	NRNT2	E229028	NRNT8		UL 508
Plug-in socket relay and accessories	Plug-in socket relays CR-M, CR-P, CR-U, CR-S Interface relay R600	NRNT2	E244330		E244330	UL 508
		NRNT2	E352056	NRNT8	E352056	UL 508

QQGQ [Power Supplies] Power Supplies, Information Technology Equipment Including Electrical Business Equipment

This category includes power supplies with rated voltages of up to 600 V, which are suitable for information technology devices (ITE) including electrical office equipment. End products in which these types of power supplies are used are referred to as information technology devices including electrical office equipment (NWWGQ). These power supplies are stand-alone units that supply power to ITE's via external interconnects. All power supply types in this category are labeled with input and output values. These include the voltage and maximum load in amps if the power supplies do not have an unpluggable power cord. A suitable cable must then also be available.

The examination of a product in this category does not consider the effects it may have on another connected system or device. One of the following markings appears on the product:

- “60950-1”
- “60950-22”
- “Information Technology Equipment Power Supply”
- “I.T.E. Power Supply”
- “ITE Power Supply”
- “QQGQ Power Supply”
- “UL 60950-1”
- “UL 60950-22”

QQGQ2 and QQGQ8 products

Component	ABB product	UL Recognized		ULc Recognized		Standard
		CCN	File no.	CCN	File no.	
Switched-mode power supplies and redundancy modules	Power Supplies CP-E, CP-D, CP-T, CP-S, CP-C	QQGQ2	E196145	QQGQ8	E196145	UL 508

Conditions

- They may only be used within a control cabinet.
- They may only be operated with their rated values.

QQPX2 Power Supplies for Use in Hazardous Locations – Component

The devices in this category are designed as components of complete systems and feature specific design elements and specified performance capabilities. They are not intended for use as stand-alone products but rather as integral parts

of comprehensive equipment. The final acceptance of these components, according to UL, depends on their proper installation and utilization within the overall system.

Products of the categories QQPX2 and QQPX8

Component	ABB product	UL Recognized		ULc Recognized		Standard
		CCN	File no.	CCN	File no.	
Power supplies and redundancy modules	Power supplies CP-E, CP-D, CP-T, CP-S, CP-C	QQPX2	E317914	QQPX8	E317914	UL 60950, UL 60950-1

Conditions

- They may only be used within a control cabinet.
- They may only be operated with their rated values.

QVNU2 Protectors, Supplementary – Component

The devices in this category are designed as components of complete systems and feature specific design elements and specified performance capabilities. They are not intended for use as stand-alone products but rather as integral parts

of comprehensive equipment. The final acceptance of these components, according to UL, depends on their proper installation and utilization within the overall system.

Products of the categories QVNU2 und QVNU8

Component	ABB product	UL Recognized		ULc Recognized		Standard
		CCN	File no.	CCN	File no.	
Circuit breakers	S200, S200P, S200M, S200MR	QVNU2	E76126	QVNU8	E76126	UL 1077
	S200M, S200MR	QVNU2	E76126	QVNU8	E76126	UL 1077, CSA 22.2 No. 235
	S200 M UC	QVNU2	E76126	QVNU8	E76126	UL 1077, CSA 22.2 No. 235
	S800C, S800S, S800HV	QVNU2	E167556	QVNU8	E167556	UL 1077, CSA 22.2 No. 235
Accessories	Auxiliary contact S800-AUX Aux/signal contact S800-AUX/ALT Motor drive S800U-RSU, S800W-RSU Working current trip S800-SOR Undervoltage release S800-UVR	QVNU2	E167556	QVNU8	E167556	UL 1077, CSA 22.2 No. 235
	Auxiliary switch/signal contacts, working current trips, phase rails	QVNU2	E76126			UL 1077, CSA 22.2 No. 235

Conditions

- According to UL, the final acceptance of the component depends on its installation and use in the complete equipment.
- These products can be used in control circuits, but not in main circuits.

SWIV2 Relay Sockets and Assemblies – Component

This category includes sockets for use with plug-in relays and assemblies consisting of relay sockets, connected wiring or printed circuit boards, and terminals for fixing cables. As with QVNU2 products are designed as components of complete systems and feature specific design

elements and specified performance capabilities. They are not intended for use as stand-alone products but rather as integral parts of comprehensive equipment. The final acceptance of these components, according to UL, depends on their proper

Products of the categories SWIV2 und SWIV8

Component	ABB product	UL Recognized		ULc Recognized		Standard
		CCN	File no.	CCN	File no.	
Plug-in socket relays and accessories	Plug-in socket relays CR-M, CR-P, CR-U e CR-S	SWIV2	E244328	SWIV8	E244328	UL 508
	Plug-in modules CR-P/M and CR-U	SWIV2	E244328	SWIV8	E244328	UL 508

Conditions

- They may only be used within a control cabinet.
- They may only be operated with their rated values.
- Tightening torque must be 7 lbs/inches.

VZCA2 Surge-Protective Devices (SPD) – Component

This category includes the following transient surge protection devices:

- Type 2 tested protective devices.
- 1, 2, 3, 4 pole version.
- Various types of networks: TNC, TNC-S, TNS, TT and IT systems.

- Other circuits: Single and split-phase, Delta, grounded wye, high-Leg Delta.
- Voltages: 120 V, 240 V, 277 V, 347 V, 480 V, 600 V.
- With and without reporting contact.

Products in categories VZCA2

Component	ABB product	UL Listed		ULc Listed		Standard
		CCN	File no.	CCN	File no.	
Surge protection device	OVR T2 1N, OVR T2 2N, OVR T2 3L, OVR T2 3N			VZCA2	E322885	UL 1449

WHTY [Switches] Switches, Open Type

This category encompasses switches without enclosures that can be easily operated with a simple wrist movement. They are designed for placement in a control panel, motor control cabinet, industrial control cabinet, certified control cabinet, or fuse box, following the instructions for switch

installation. The installation is versatile, allowing for specific applications, and, in some cases, can be executed without the need for an enclosure. These switches are intended to be affixed to an enclosure that enables external operation without requiring the enclosure to be opened.

Products of the categories WHTY and WHTY7

Component	ABB product	UL Listed		ULc Listed		Standard
		CCN	File no.	CCN	File no.	
Switch disconnectors	Switch disconnectors OT series (30, 560, 100 A)	WHTY	E101914	WHTY7	E101914	UL98
	Switch disconnectors series OS_J	WHTY	E101914	WHTY7	E101914	UL98

WHVA [Switches] Switches, Open Type for Use in Photovoltaic Systems

This category encompasses switches without enclosures designed for use in photovoltaic (PV) systems, operable with a simple wrist movement. They are meant to be installed in an electrical panel, a certified control cabinet, or a fuse box following the installation guidelines for photovoltaic switches outlined in Article 690 of ANSI/NFPA 70 (NEC). These open switches should be affixed to a housing that allows external operation without requiring the housing to be opened.

If replacement becomes necessary, it can be carried out. Unless otherwise specified, these switches must be connected using copper conductors. PV switches are also labeled with their rated voltage (up to 1,500 V DC), rated current, and short-circuit current. Open PV switches are marked with identifiers such as "Photovoltaic," "PV Disconnect Switch," or "Suitable for Use in Photovoltaic Systems" and bear the designation "By Article 690 of the NEC."

Products of the categories WHVA and WHVA7

Component	ABB product	UL Listed		ULc Listed		Standard
		CCN	File no.	CCN	File no.	
Switch disconnectors	Switch disconnectors series OTDC_U	WHVA	E354681	WHVA7	E354681	UL98B

WJAZ [Switches] Switches, Molded Case

This category includes fuseless compact switches. The maximum voltage of these switches is 600 V. Fuse-less switches are tested to see if their marked nominal load can withstand continuous operation. They are tested under overload conditions at six times the rated current values to verify that they meet the requirements of Section 430.109 ANSI/NFPA 70 (NEC) as load separators in the motor circuit. If they are not marked for use with aluminum conductors, they must be wired with copper conductors. Such markings are

regardless of the markings on the terminals. Compact switches without enclosures are intended for use in certified circuit breaker housings as part of other certified equipment or where compact switches can be used.

As circuit breakers, compact switches are equipped with an overcurrent device and a tripping mechanism that ensures that the switch opens automatically in the event of a short-circuit.

Products in category WJAZ

Component	ABB product	UL Listed		ULc Listed		Standard
		CCN	File no.	CCN	File no.	
Switch disconnectors	Tmax XT: Compact switch -MCS	WJAZ	E116595			UL 489, CSA 22.2 No.5.1

ABB Oy

Muottitie 2
65320 Vaasa Ostrobothnia
Finland

—

ABB France

2 rue d'Arsonval
69687 Chassieu cedex
France

—

ABB STOTZ-KONTAKT GmbH

Eppelheimer Straße 82
69123 Heidelberg
Germany

—

ABB S.p.A.

Via Pescaria
5 24123 Bergamo
Italy

—

ABB Electrification Sweden AB

Motor Starting and Safety
721 61 Västerås
Sweden

**You can find the address of your local
sales organization on the ABB homepage**



abb.com/lowvoltage

**Additional information**

We reserve the right to make technical changes or modify the contents of this document without prior notice. With regard to purchase orders, the agreed particulars shall prevail. ABB AG does not accept any responsibility whatsoever for potential errors or possible lack of information in this document.

We reserve all rights in this document and in the subject matter and illustrations contained therein. Any reproduction, disclosure to third parties or utilization of its contents – in whole or in parts – is forbidden without prior written consent of ABB AG.
Copyright© 2024 ABB
All rights reserved