



The Company

We are an established world force in the design and manufacture of instrumentation for industrial process control, flow measurement, gas and liquid analysis and environmental applications.

As a part of ABB, a world leader in process automation technology, we offer customers application expertise, service and support worldwide.

We are committed to teamwork, high quality manufacturing, advanced technology and unrivalled service and support.

The quality, accuracy and performance of the Company's products result from over 100 years experience, combined with a continuous program of innovative design and development to incorporate the latest technology.

The UKAS Calibration Laboratory No. 0255 is just one of the ten flow calibration plants operated by the Company and is indicative of our dedication to quality and accuracy.

EN ISO 9001:2000



Cert. No. Q 05907

EN 29001 (ISO 9001)



Lenno, Italy – Cert. No. 9/90A

Stonehouse, U.K.



0255

Use of Instructions



Warning.

An instruction that draws attention to the risk of injury or death.



Note.

Clarification of an instruction or additional information.



Caution.

An instruction that draws attention to the risk of damage to the product, process or surroundings.



Information.

Further reference for more detailed information or technical details.

Although Warning hazards are related to personal injury, and Caution hazards are associated with equipment or property damage, it must be understood that operation of damaged equipment could, under certain operational conditions, result in degraded process system performance leading to personal injury or death. Therefore, comply fully with all Warning and Caution notices.

Information in this manual is intended only to assist our customers in the efficient operation of our equipment. Use of this manual for any other purpose is specifically prohibited and its contents are not to be reproduced in full or part without prior approval of the Marketing Communications Department.

Health and Safety

To ensure that our products are safe and without risk to health, the following points must be noted:

1. The relevant sections of these instructions must be read carefully before proceeding.
2. Warning labels on containers and packages must be observed.
3. Installation, operation, maintenance and servicing must only be carried out by suitably trained personnel and in accordance with the information given.
4. Normal safety precautions must be taken to avoid the possibility of an accident occurring when operating in conditions of high pressure and/or temperature.
5. Chemicals must be stored away from heat, protected from temperature extremes and powders kept dry. Normal safe handling procedures must be used.
6. When disposing of chemicals ensure that no two chemicals are mixed.

Safety advice concerning the use of the equipment described in this manual or any relevant hazard data sheets (where applicable) may be obtained from the Company address on the back cover, together with servicing and spares information.

CONTENTS

BOOK 2 MECHANICAL INSTALLATION

Contents	Page
SAFETY MEASURES	1
1 INTRODUCTION	1
2 INSTALLATION CONDITIONS	2
3 INSTALLATION	4
3.1 Transmitters	4
3.1.1 Location	4
3.1.2 Mounting	4
3.2 Sensors	5

1 INTRODUCTION

This book describes the mechanical installation of MagMaster™ and AquaMag ranges of electromagnetic flowmeters.

Attention to safety measures, installation conditions and general precautions will ensure trouble free operation.



Note. Not all available versions are approved. Mechanical Installation covers general aspects of both approved and non-approved products.



Warning.

- Installation and maintenance must only be carried out by suitably trained personnel.
- HAZARDOUS AREA DESIGNATION ON THE EQUIPMENT LABEL MUST BE SUITABLE FOR THE INTENDED DUTY AND LOCATION.
- All relevant sections of this manual must be read before selecting a location.
- Safety requirements of this equipment, any associated equipment, and the local environment must be taken into consideration.
- The installation and use of this equipment must be in accordance with relevant national and local standards.



Warning.

- Mating Hygienic end connections, clamps and supplied gaskets as ordered may have a lower pressure and temperature limit than that shown on the sensor data label.

2 INSTALLATION CONDITIONS

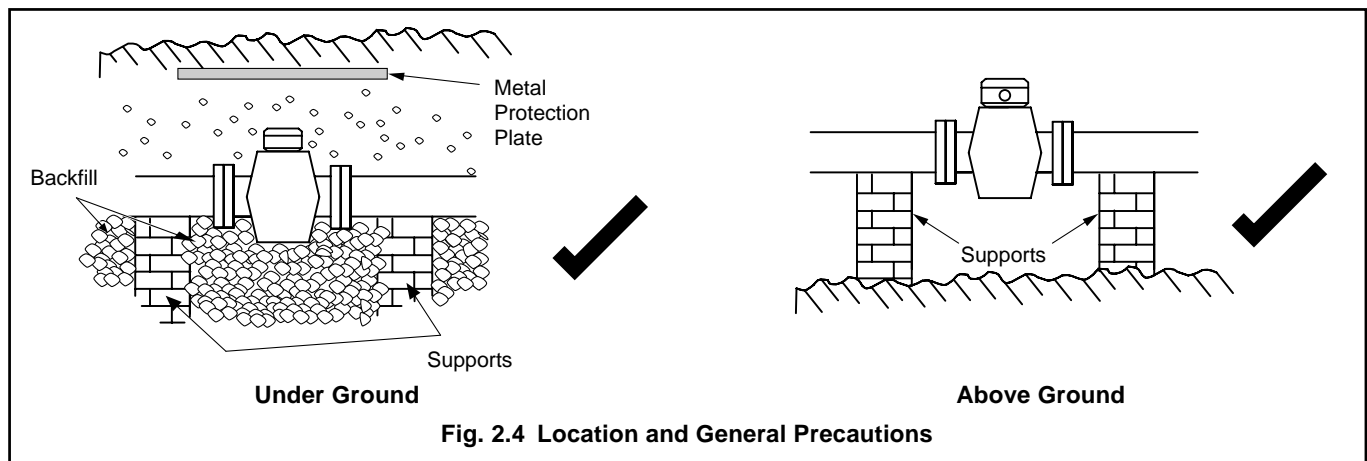
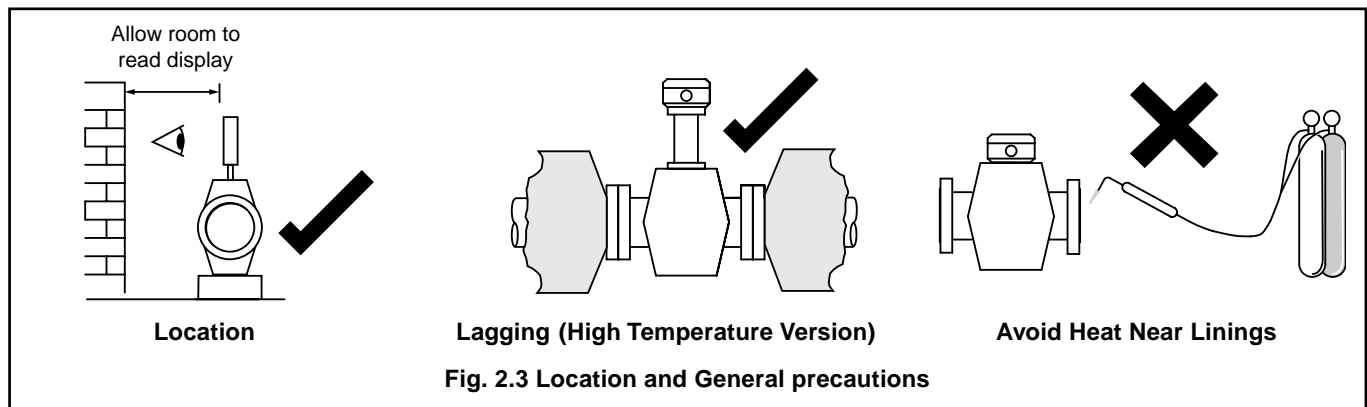
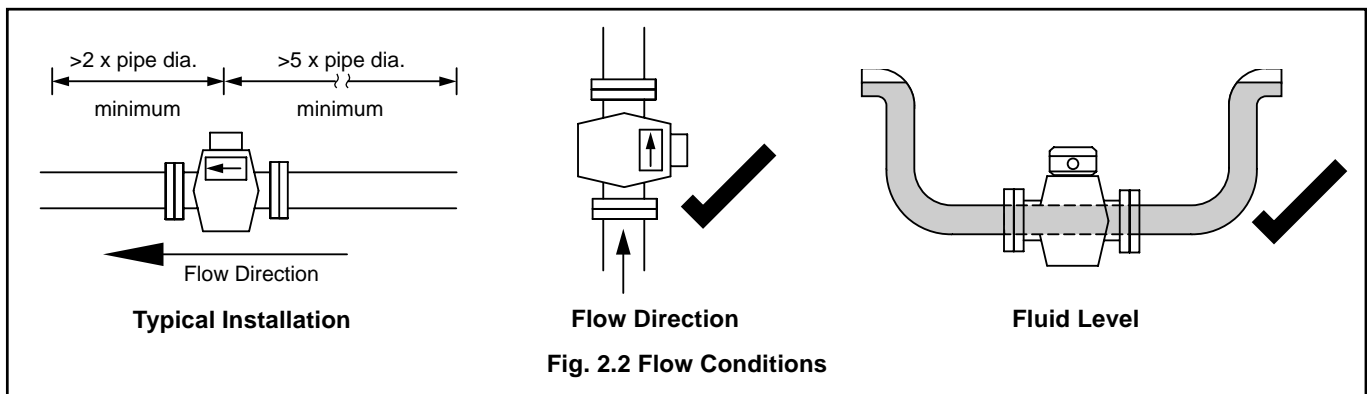
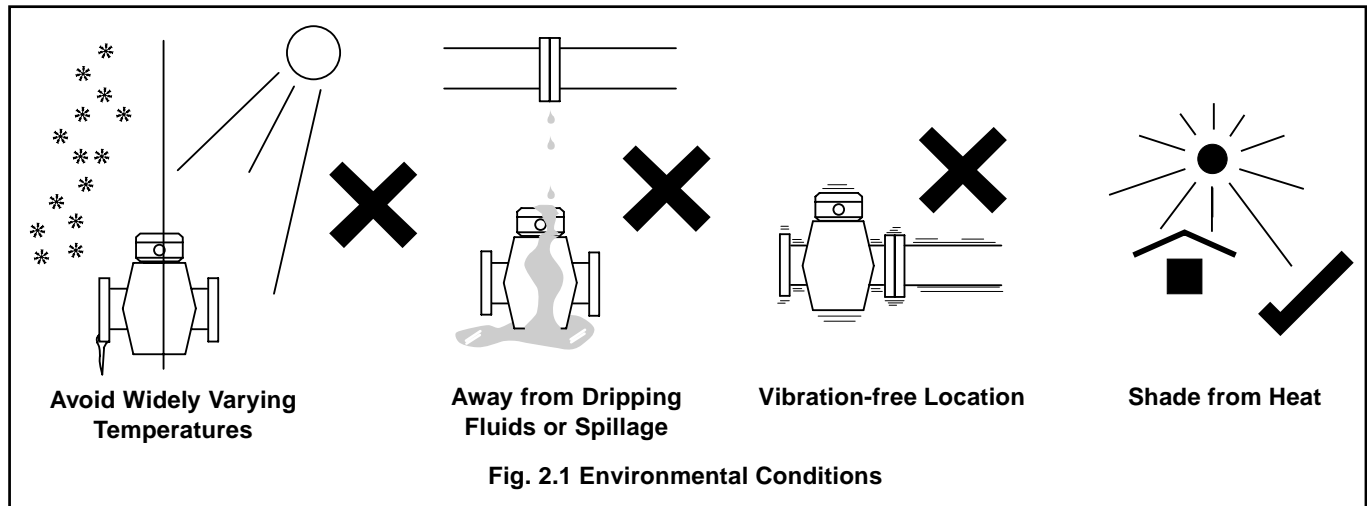

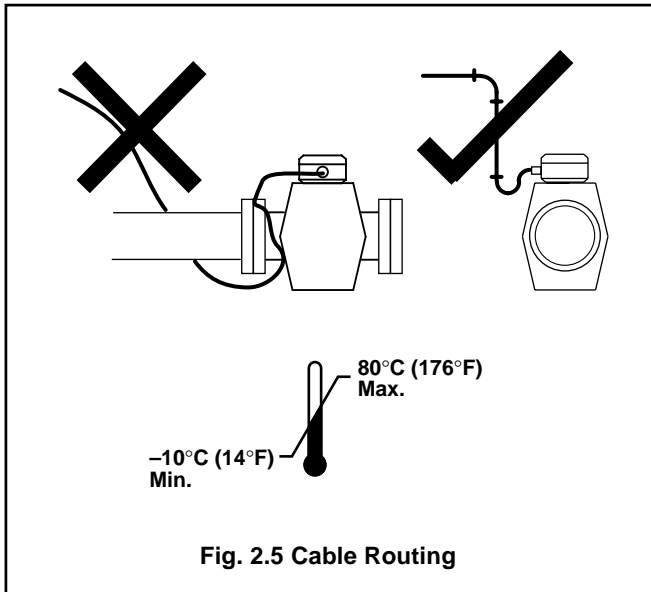

Fig. 2.5 Cable Routing

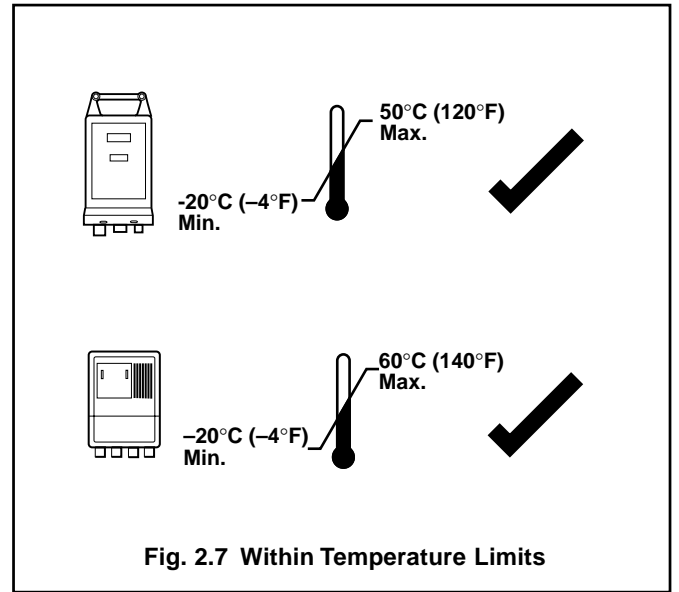

Fig. 2.7 Within Temperature Limits

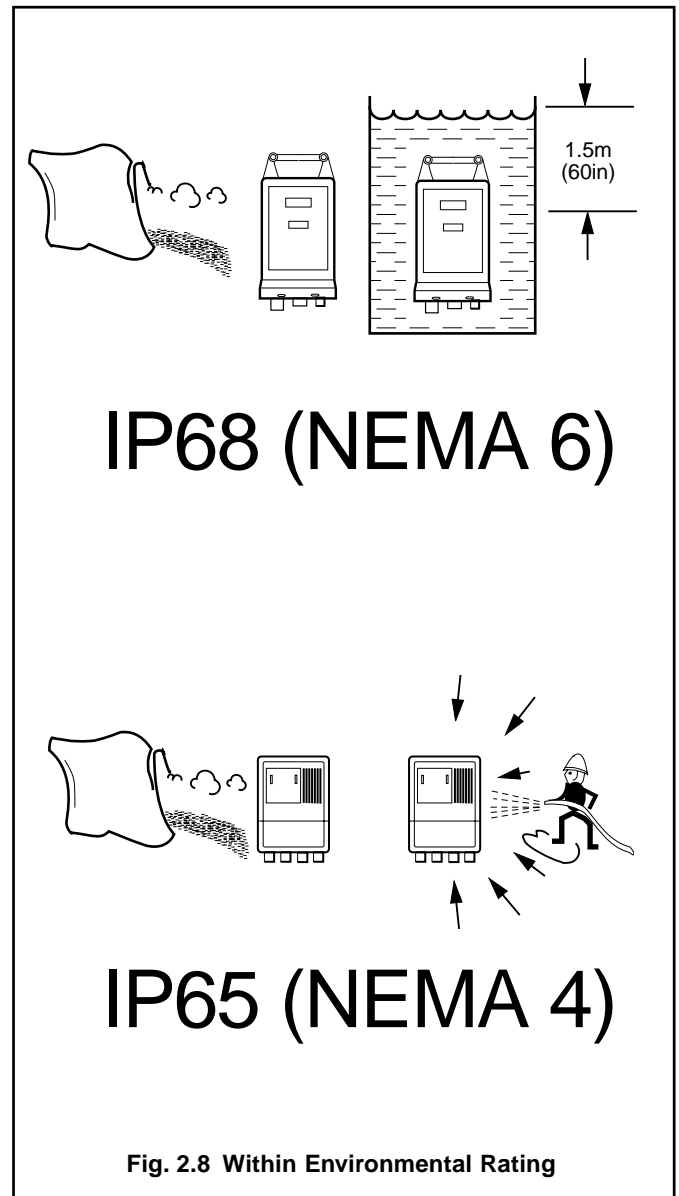
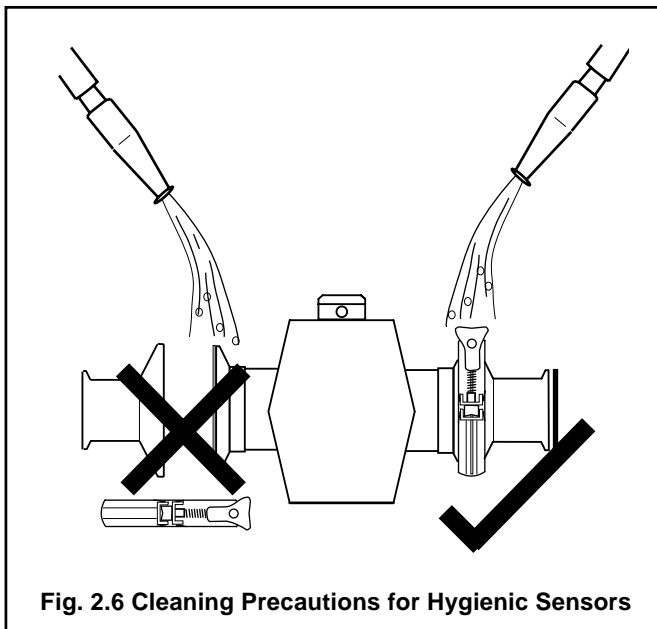

Fig. 2.8 Within Environmental Rating

3 INSTALLATION

3.1 Transmitter

3.1.1 Location

Select a location where the transmitter unit will not be subject to undue vibration or exposed to environmental conditions beyond the degree of protection. The location chosen should be free from harsh electrical noise such as that from adjacent equipment, cables, r.f.i. or e.m.i.

3.1.2 Mounting



Caution. Do not overtighten fixings, especially on an uneven surface.

Providing that free access is available to allow the display to be viewed as required, the unit can be either wall mounted or panel mounted with masonry fixings or nuts and bolts respectively via the fixing holes provided.

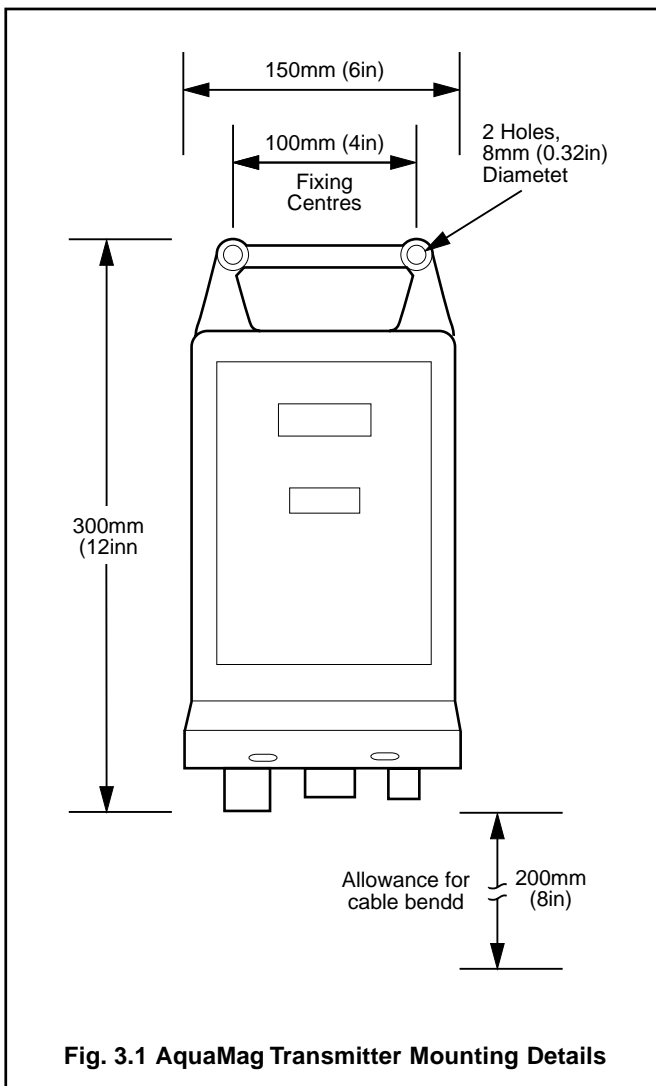

Fig. 3.1 AquaMag Transmitter Mounting Details

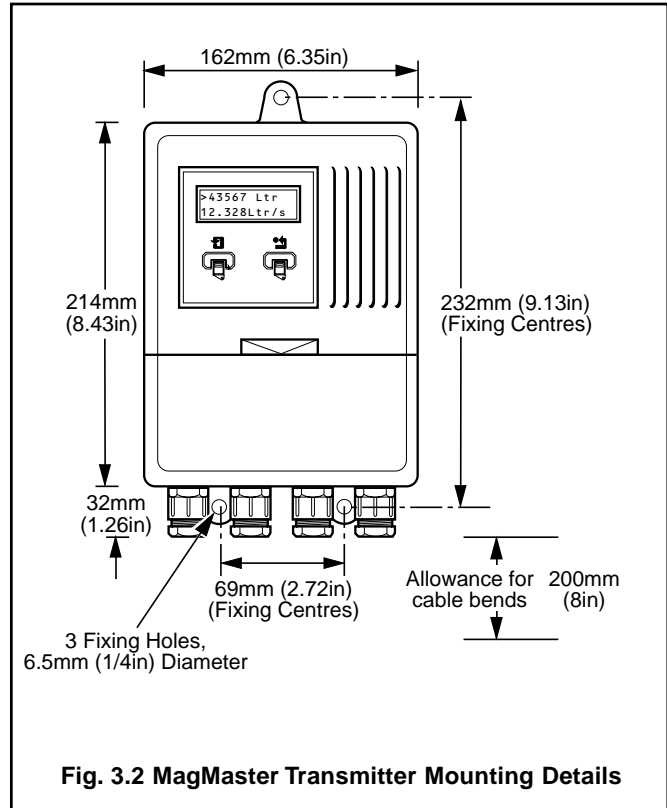

Fig. 3.2 MagMaster Transmitter Mounting Details

3.2 Sensors



Caution.

- Do NOT exceed the maximum working pressure marked on the equipment.
- Use stainless steel (austenitic) bolts, studs and nuts for flanged sensors below 200mm bore.

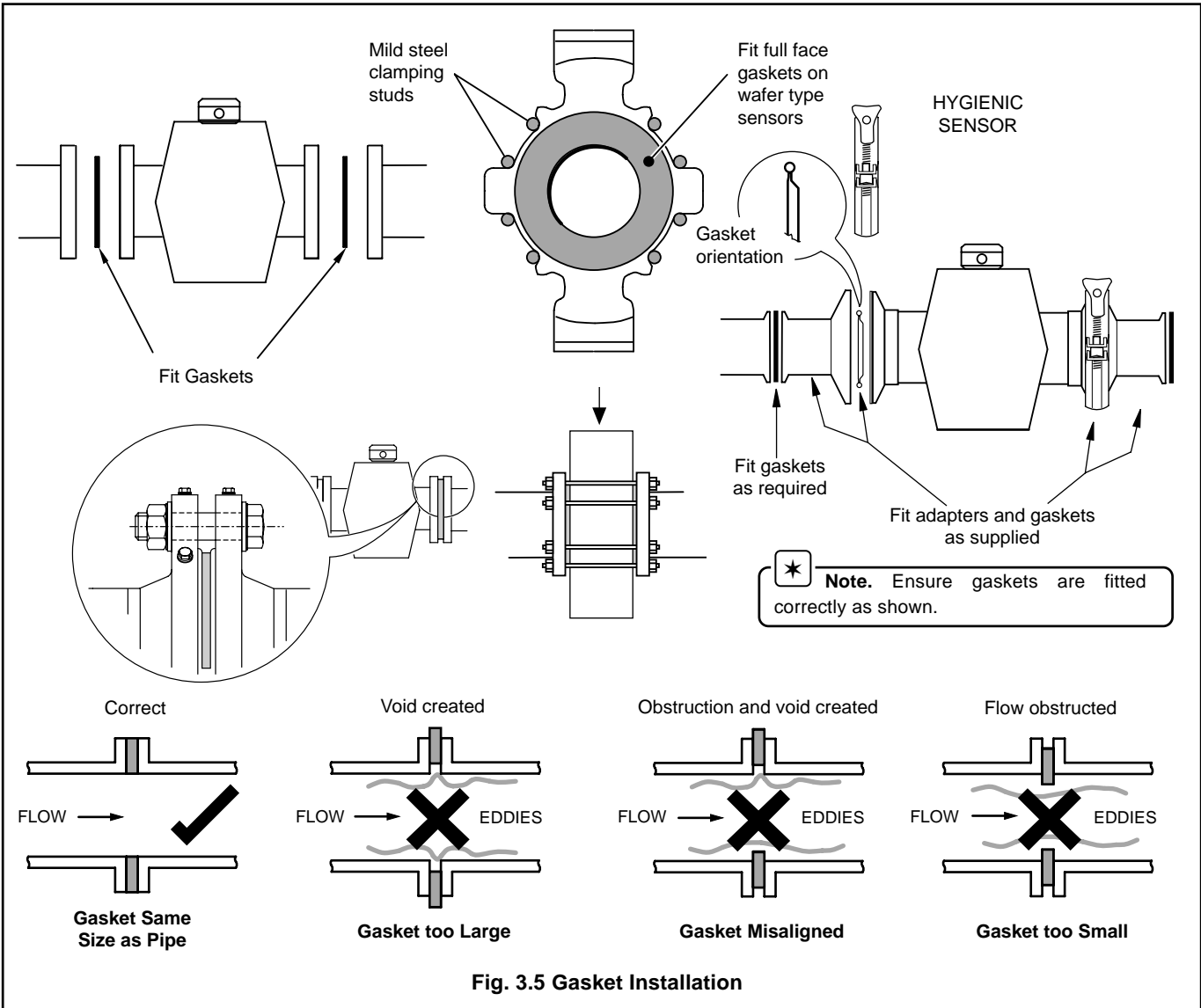
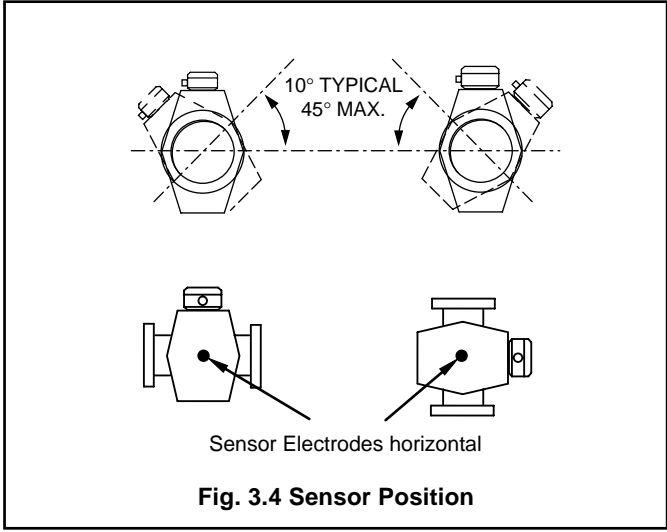
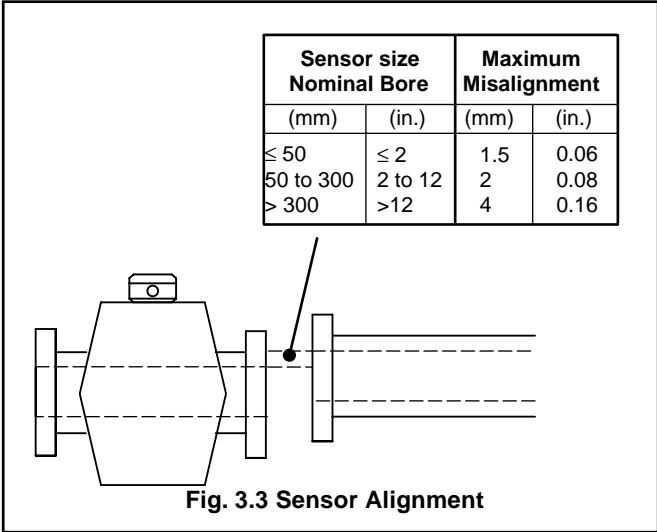

...3 INSTALLATION



Caution. Do not rely on flange bolts or studs for electrical connection.



Information. See ELECTRICAL INSTALLATION book for ground wiring.

...3.2 Sensors

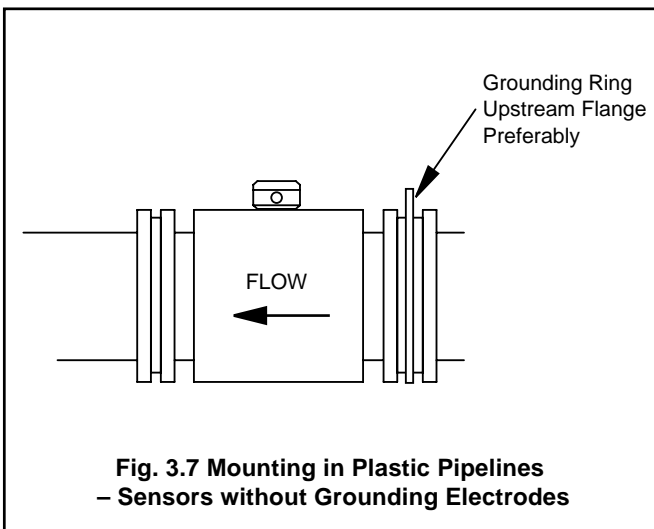
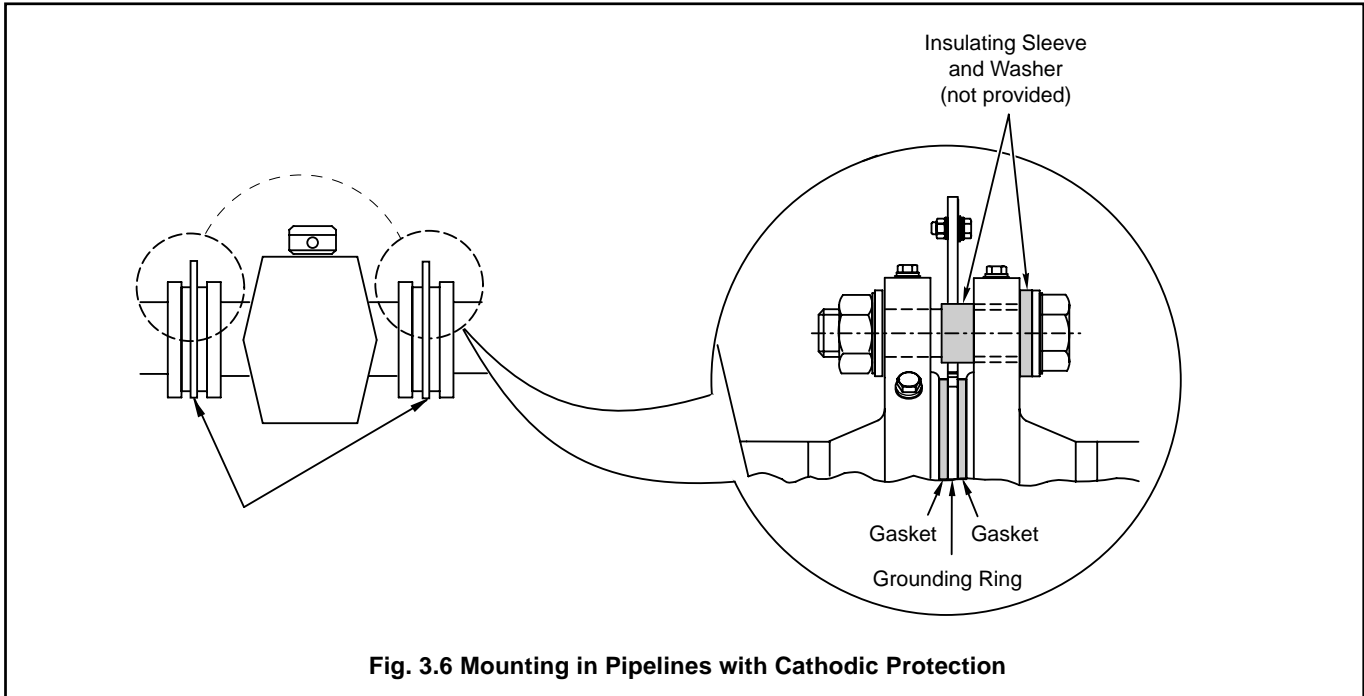

NOTES

PRODUCTS & CUSTOMER SUPPORT

Products

Automation Systems

- *for the following industries:*
 - Chemical & Pharmaceutical
 - Food & Beverage
 - Manufacturing
 - Metals and Minerals
 - Oil, Gas & Petrochemical
 - Pulp and Paper

Drives and Motors

- *AC and DC Drives, AC and DC Machines, AC motors to 1kV*
- *Drive systems*
- *Force Measurement*
- *Servo Drives*

Controllers & Recorders

- *Single and Multi-loop Controllers*
- *Circular Chart, Strip Chart and Paperless Recorders*
- *Paperless Recorders*
- *Process Indicators*

Flexible Automation

- *Industrial Robots and Robot Systems*

Flow Measurement

- *Electromagnetic Flowmeters*
- *Mass Flow Meters*
- *Turbine Flowmeters*
- *Flow Elements*

Marine Systems & Turbochargers

- *Electrical Systems*
- *Marine Equipment*
- *Offshore Retrofit and Refurbishment*

Process Analytics

- *Process Gas Analysis*
- *Systems Integration*

Transmitters

- *Pressure*
- *Temperature*
- *Level*
- *Interface Modules*

Valves, Actuators and Positioners

- *Control Valves*
- *Actuators*
- *Positioners*

Water, Gas & Industrial Analytics Instrumentation

- *pH, conductivity, and dissolved oxygen transmitters and sensors*
- *ammonia, nitrate, phosphate, silica, sodium, chloride, fluoride, dissolved oxygen and hydrazine analyzers.*
- *Zirconia oxygen analyzers, katharometers, hydrogen purity and purge-gas monitors, thermal conductivity.*

Customer Support

We provide a comprehensive after sales service via a Worldwide Service Organization. Contact one of the following offices for details on your nearest Service and Repair Centre.

United Kingdom

ABB Limited
Tel: +44 (0)1453 826661
Fax: +44 (0)1453 827856

United States of America

ABB Inc.
Tel: +1 (0) 755 883 4366
Fax: +1 (0) 755 883 4373

Client Warranty

Prior to installation, the equipment referred to in this manual must be stored in a clean, dry environment, in accordance with the Company's published specification.

Periodic checks must be made on the equipment's condition. In the event of a failure under warranty, the following documentation must be provided as substantiation:

1. A listing evidencing process operation and alarm logs at time of failure.
2. Copies of all storage, installation, operating and maintenance records relating to the alleged faulty unit.

ABB has Sales & Customer Support
expertise in over 100 countries worldwide

www.abb.com

The Company's policy is one of continuous product
improvement and the right is reserved to modify the
information contained herein without notice.

Printed in UK (03.04)

© ABB 2004



ABB Limited

Oldends Lane, Stonehouse
Gloucestershire
GL10 3TA
UK
Tel: +44 (0)1453 826661
Fax: +44 (0)1453 829671

ABB Inc.

125 E. County Line Road
Warminster
PA 18974
USA
Tel: +1 215 674 6000
Fax: +1 215 674 7183