

Installation Manual

615 series



ABB



Document ID: 1MRS756375
Issued: 03.10.2008
Revision: D
Product version: 1.1

© Copyright 2008 ABB. All rights reserved

Copyright

This document and parts thereof must not be reproduced or copied without written permission from ABB, and the contents thereof must not be imparted to a third party, nor used for any unauthorized purpose.

The software or hardware described in this document is furnished under a license and may be used, copied, or disclosed only in accordance with the terms of such license.

Trademarks

ABB is a registered trademark of ABB Group. All other brand or product names mentioned in this document may be trademarks or registered trademarks of their respective holders.

Guarantee

Please inquire about the terms of guarantee from your nearest ABB representative.

ABB Oy

Distribution Automation

P.O. Box 699

FI-65101 Vaasa, Finland

Telephone: +358 10 2211

Facsimile: +358 10 22 41094

<http://www.abb.com/substationautomation>

Disclaimer

The data, examples and diagrams in this manual are included solely for the concept or product description and are not to be deemed as a statement of guaranteed properties. All persons responsible for applying the equipment addressed in this manual must satisfy themselves that each intended application is suitable and acceptable, including that any applicable safety or other operational requirements are complied with. In particular, any risks in applications where a system failure and/or product failure would create a risk for harm to property or persons (including but not limited to personal injuries or death) shall be the sole responsibility of the person or entity applying the equipment, and those so responsible are hereby requested to ensure that all measures are taken to exclude or mitigate such risks.

This document has been carefully checked by ABB but deviations cannot be completely ruled out. In case any errors are detected, the reader is kindly requested to notify the manufacturer. Other than under explicit contractual commitments, in no event shall ABB be responsible or liable for any loss or damage resulting from the use of this manual or the application of the equipment.

Conformity

This product complies with the directive of the Council of the European Communities on the approximation of the laws of the Member States relating to electromagnetic compatibility (EMC Council Directive 2004/108/EC) and concerning electrical equipment for use within specified voltage limits (Low-voltage directive 2006/95/EC). This conformity is the result of a test conducted by ABB in accordance with Article 10 of the directive in agreement with the product standards EN 50263 and EN 60255-26 for the EMC directive, and with the product standards EN 60255-6 and EN 60255-27 for the low voltage directive. The IED is designed in accordance with the international standards of the IEC 60255 series.

Safety information



Dangerous voltages can occur on the connectors, even though the auxiliary voltage has been disconnected.



Non-observance can result in death, personal injury or substantial property damage.



Only a competent electrician is allowed to carry out the electrical installation.



National and local electrical safety regulations must always be followed.



The frame of the device has to be carefully earthed.



When the plug-in unit has been detached from the case, do not touch the inside of the case. The relay case internals may contain high voltage potential and touching these may cause personal injury.



The device contains components which are sensitive to electrostatic discharge. Unnecessary touching of electronic components must therefore be avoided.

Table of contents

Section 1	Introduction.....	3
	This manual.....	3
	Intended audience.....	3
	Product documentation.....	4
	Product documentation set.....	4
	Document revision history.....	5
	Related documentation.....	6
	Document symbols and conventions.....	6
	Safety indication symbols.....	6
	Document conventions.....	6
Section 2	Environmental aspects.....	9
	Sustainable development.....	9
	Disposing of the IED.....	9
Section 3	Unpacking, inspecting and storing.....	11
	Unpacking and inspecting the IED.....	11
	Identifying the product.....	11
	Returning the IED damaged in transit.....	11
	Storing.....	12
Section 4	Mounting.....	13
	Checking environmental conditions and mounting space.....	13
	Detaching and installing the plug-in unit.....	13
	Detaching the plug-in unit.....	13
	Installing the plug-in unit.....	14
	Mounting the IED.....	15
	Flush mounting the IED.....	15
	Semi-flush mounting the IED.....	19
	Semi-flush mounting the IED inclined.....	21
	Rack mounting the IED.....	23
	Wall mounting the IED.....	25
	Rack mounting the IED and test switch RTXP to a 19" equipment frame.....	28
	Rack mounting the IED in a combiflex 19" equipment frame.....	30
	Mounting lens sensors for an arc protection system.....	32
Section 5	Connecting.....	35
	Required tools.....	35
	Connecting wires.....	35

Table of contents

	Connecting ring-lug type wires.....	36
	Connecting protective earthing.....	36
	Connecting analog signals.....	37
	Connecting current and voltage inputs.....	38
	Connecting IED with test switches.....	40
	Connecting power supply.....	40
	Connecting communication.....	41
	Energizing the IED.....	41
Section 6	De-installing, repairing and exchanging.....	43
	Product lifecycle.....	43
	Checking IED information.....	43
	De-installing the IED.....	44
	Sending the IED for repair.....	44
	Exchanging the IED.....	45
Section 7	Technical data.....	47
	Case and HMI display variants.....	47
	Front side of the IED.....	47
	Rear side of the IED.....	49
	Dimensions.....	49
	Mounting dimensions.....	50
	Inputs and outputs.....	50
	Power supply.....	50
	Energizing inputs.....	51
	Binary inputs.....	52
	Signal outputs.....	52
	Power outputs.....	52
	Data communication for front interface.....	53
	Installation definitions.....	53
	Lens sensor and optic fibre for arc protection.....	53
	Enclosure class.....	54
	Environmental conditions and tests.....	54
Section 8	Accessories and ordering data.....	57
Section 9	Glossary.....	59

Section 1 Introduction

1.1 This manual

Installation Manual contains instructions on how to install the IED. The manual provides procedures for mechanical and electrical installation. The chapters are organized in the chronological order in which the protection IED should be installed.

1.2 Intended audience

This manual addresses the personnel responsible for installing the product hardware.

The installation personnel must have basic knowledge of handling electronic equipment.

1.3 Product documentation

1.3.1 Product documentation set

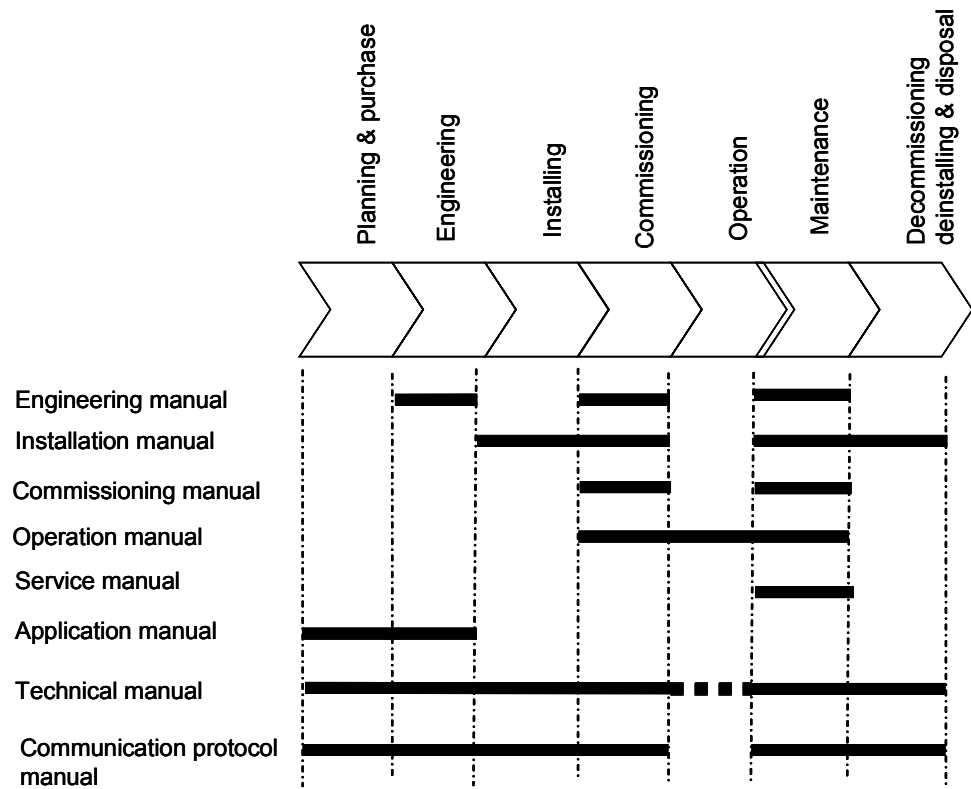

en07000220.vsd

Engineering Manual contains instructions on how to engineer the IEDs. The manual provides instructions on how to use the different tools for IED engineering. It also includes instructions on how to handle the tool component available to read disturbance files from the IEDs on the basis of the IEC 61850 definitions. It further introduces the diagnostic tool components available for IEDs and the PCM600 tool.

Installation Manual contains instructions on how to install the IED. The manual provides procedures for mechanical and electrical installation. The chapters are organized in the chronological order in which the protection IED should be installed.

Commissioning Manual contains instructions on how to commission the IED. The manual can also be used as a reference during periodic testing. The manual provides procedures for energizing and checking of external circuitry, setting and configuration as well as verifying settings and performing directional tests. The chapters are organized in the chronological order in which the IED should be commissioned.

Operation Manual contains instructions on how to operate the IED during normal service once it has been commissioned. The manual can be used to find out how to handle disturbances or how to view calculated and measured network data in order to determine the cause of a fault.

Service Manual contains instructions on how to service and maintain the IED. The manual also provides procedures for de-energizing, de-commissioning and disposal of the IED.

Application Manual contains application descriptions and setting guidelines sorted per function. The manual can be used to find out when and for what purpose a typical protection function can be used. The manual can also be used when calculating settings.

Technical Manual contains application and functionality descriptions and lists function blocks, logic diagrams, input and output signals, setting parameters and technical data sorted per function. The manual can be used as a technical reference during the engineering phase, installation and commissioning phase, and during normal service.

The Communication Protocol manuals describe the different communication protocols supported by the IED. The manuals concentrate on vendor-specific implementations.

The Point List Manual describes the outlook and properties of the data points specific to the IED. This manual should be used in conjunction with the corresponding Communication Protocol Manual.



All manuals are not available yet.

1.3.2

Document revision history

Document revision/date	Platform version	History
A/20.12.2007	1.0	First release
B/08.02.2008	1.0	Content updated
C/02.07.2008	1.1	Content updated to correspond to the platform version
D/03.10.2008	1.1	Content updated



The latest revision of the document can be downloaded from the ABB web site <http://www.abb.com/substationautomation>

1.3.3 Related documentation

Product- and platform-specific manuals can be downloaded from the ABB web site <http://www.abb.com/substationautomation>.

1.4 Document symbols and conventions

1.4.1 Safety indication symbols

This publication includes the following icons that point out safety-related conditions or other important information:



The electrical warning icon indicates the presence of a hazard which could result in electrical shock.



The warning icon indicates the presence of a hazard which could result in personal injury.



The caution icon indicates important information or warning related to the concept discussed in the text. It might indicate the presence of a hazard which could result in corruption of software or damage to equipment or property.



The information icon alerts the reader to relevant facts and conditions.





The tip icon indicates advice on, for example, how to design your project or how to use a certain function.

Although warning hazards are related to personal injury, it should be understood that operation of damaged equipment could, under certain operational conditions, result in degraded process performance leading to personal injury or death. Therefore, comply fully with all warning and caution notices.

1.4.2 Document conventions

The following conventions are used for the presentation of material:

-
- Abbreviations in this manual are spelled out in the section "Glossary". In addition, the section contains descriptions on several terms.
 - Push button navigation in the HMI menu structure is presented by using the push button icons, for example:
To navigate between the options, use  and .
 - HMI menu paths are presented as follows:
Select **Main menu/Configuration/HMI**.
 - Menu names are shown in bold in WHMI, for example:
Click **Information** in the WHMI menu structure.
 - HMI messages are shown in Courier font, for example:
To save the changes in non-volatile memory, select Yes and press .
 - Parameter names are shown in italics, for example:
The function can be enabled and disabled with the *Operation* setting.
 - Parameter values are indicated with quotation marks, for example:
The corresponding parameter values are "On" and "Off".
 - IED input/output messages and monitored data names are shown in Courier font, for example:
When the function starts, the START output is set to TRUE.

Section 2 Environmental aspects

2.1 Sustainable development

Sustainability has been taken into account from the beginning of the product design including the pro-environmental manufacturing process, long life time, operation reliability and disposing of the IED.

The choice of the materials and the suppliers has been made according to the EU RoHS directive (2002/95/EC). This directive limits the use of hazardous substances which are the following:

Table 1: *Maximum concentration values by weight per homogeneous material*

Substance	Proposed maximum concentration
Lead - Pb	0,1%
Mercury - Hg	0,1%
Cadmium - Cd	0,01%
Hexavalent Chromium Cr (VI)	0,1%
Polybrominated biphenyls - PBB	0,1%
Polybrominated diphenyl ethers - PBDE	0,1%

Operational reliability and long life time have been assured with extensive testing during the design and manufacturing processes. Moreover, long life time is supported by maintenance and repair services as well as by the availability of spare parts.

Design and manufacturing have been done under a certified environmental system. The effectiveness of the environmental system is constantly evaluated by an external auditing body. We follow environmental rules and regulations systematically to evaluate their effect on our products and processes.

2.2 Disposing of the IED

Definitions and regulations of hazardous materials are country-specific and change when the knowledge of materials increases. The materials used in this product are typical for electric and electronic devices.

All parts used in this product are recyclable. When disposing cast-off IEDs or its parts, contact the local enterprisers who are authorized and specialized in handling

electrical/electronics waste. These partners can sort the material by using dedicated sorting processes and dispose the product according to the local requirements.

Table 2: Materials of the IED parts

IED	Parts	Material
Case	Metallic plates, parts and screws	Steel
	Plastic parts	PC ¹⁾ , LCP ²⁾
	Electronics plug in module	Various
Plug-in unit	Electronics plug in modules	Various
	Electronics LHMI module	Various
	Plastic parts	PC, PBT ³⁾ , LCP, PA ⁴⁾
	Metallic plate	Steel
Package	Box	Cardboard
Attached material	Manuals	Paper

- 1) Polycarbonate
- 2) Liquid crystal polymer
- 3) Polybutylene terephthalate
- 4) Polyamide

Section 3 Unpacking, inspecting and storing

3.1 Unpacking and inspecting the IED

IEDs require careful handling before installation on site. Examine the delivered products to ensure that they have not been damaged during the transport.

1. Remove the transport packing carefully without force.



Do not use inappropriate tools.

2. Check the IED for transport damages.
If you discover transport damages, make a claim against the transport contractor, and notify the local ABB representative.
3. Check that all items are included in the delivery in accordance with the delivery documents.
4. Notify local ABB immediately if there are any discrepancies in relation to the delivery documents.

If the IED is not installed immediately, store it in the original transport casing in a dry and dust free place. Observe the environmental requirements stated in the technical data.

3.1.1 Identifying the product

The product is unpacked and no transport damages have been discovered.

- Compare the order number of the IED with the ordering information to verify that you have received the right product.

3.1.2 Returning the IED damaged in transit

If transport damages are discovered, appropriate actions must be taken against the latest carrier, and the nearest ABB office or representative shall be informed. ABB should be notified immediately if there are any discrepancies in relation to the delivery documents.

3.2 Storing

If the IED is stored before installation, it must be done in the original transport casing in a dry and dust free place. Observe the environmental requirements stated in the technical data.

Section 4 Mounting

4.1 Checking environmental conditions and mounting space

The mechanical and electrical environmental conditions at the installation site must be within the limits described in the technical data.

- Avoid installation in dusty, damp places.
Avoid places susceptible to rapid temperature variations, powerful vibrations and shocks, surge voltages of high amplitude and fast rise time, strong induced magnetic fields or similar extreme conditions.
- Check that sufficient space is available.
To allow access for maintenance and future modifications, sufficient space is needed at the front and rear of the IED.
- Flush mounted IEDs should be possible to be added or replaced without excessive dismantling.

4.2 Detaching and installing the plug-in unit

4.2.1 Detaching the plug-in unit



Before detaching the plug-in unit from the case, the auxiliary voltage must be disconnected.

To detach the plug-in unit:

1. Turn off the power.
2. Lift the lower handle until the spring-loaded locks on both sides of the handle are released.
The unit is pushed about 6 mm out of the case and the connectors are separated.
3. Pull the unit out of the case.

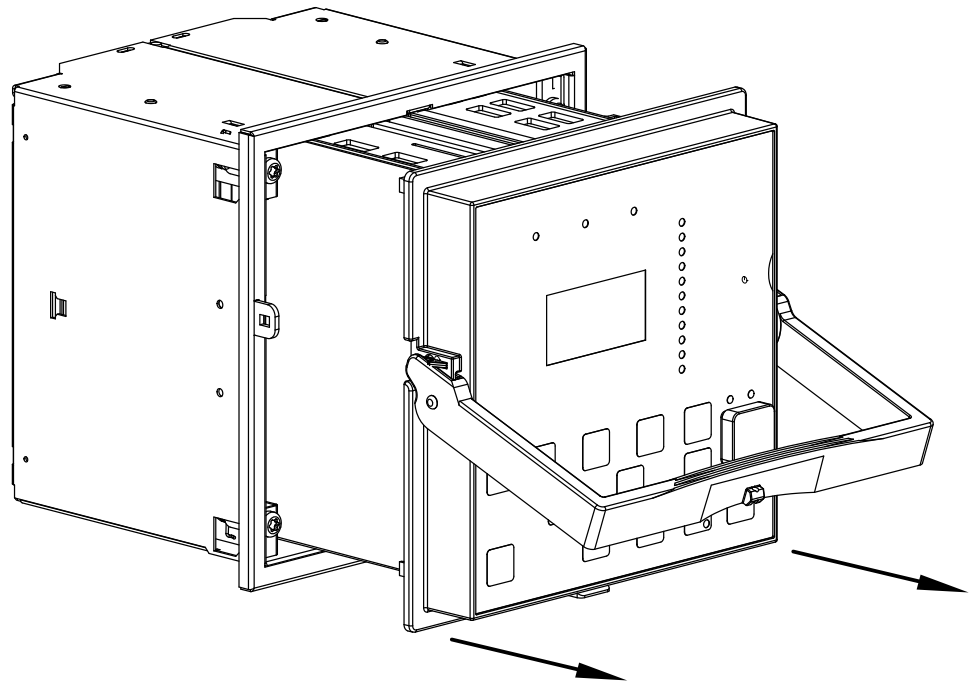

Figure 1: Detaching a plug-in unit from the case



The IED features an automatic short-circuit mechanism in the CT connector. Therefore, detaching the plug-in unit will not open the secondary circuit of the CT which could cause dangerously high voltages.



The signal connectors are left open when the plug-in unit is detached.

4.2.2

Installing the plug-in unit



Before fitting the plug-in unit into the case, check that the unit and the case have the same ordering code.

The IED is built so that a plug-in unit with voltage or current measuring inputs can only be plugged into a corresponding case. This prevents fitting a non-suitable plug-in unit into a wrong case.



Forcing a non-suitable plug-in unit into the case can break both the plug-in unit and the case and may cause danger.

To install a plug-in unit:

1. Check that the handle is down in its initial position.
2. Push the unit into the case until the locks click.

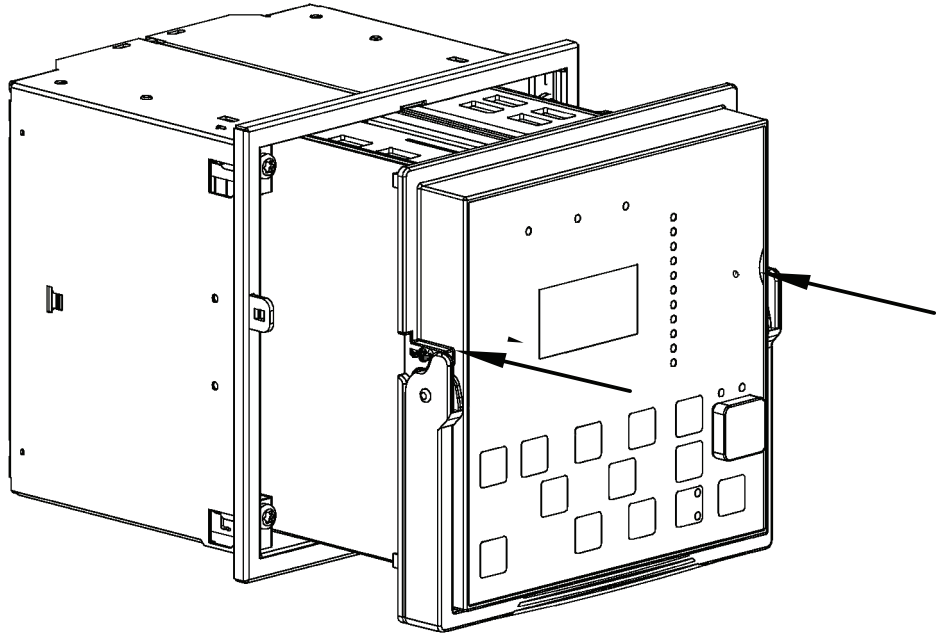

Figure 2: Installing a plug-in unit into the case

4.3 Mounting the IED

4.3.1 Flush mounting the IED

All the mounting elements are integrated in the IED.

Requirements for installation:

- Panel cut-out of 165,5 x 161,5 mm
- Depth behind the panel 153 mm

To flush mount the IED:

1. Loosen the four M5 fixing screws in the case to fit the case into the panel cut-out.
2. Mount the case to the panel cut-out.

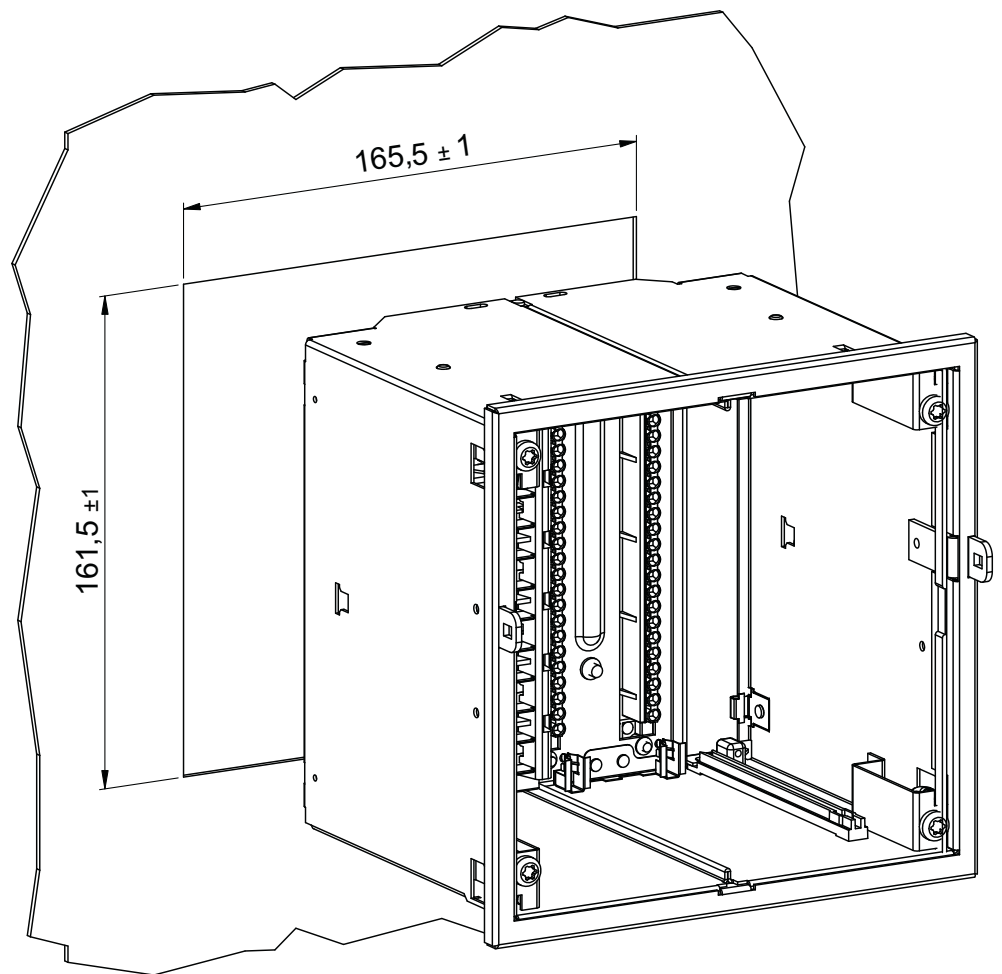

Figure 3: Flush mounting a case into a panel cut-out

3. Tighten the M5 screws.
The allowed range for the fixing screws' tightening torque is 0.7...1 Nm.

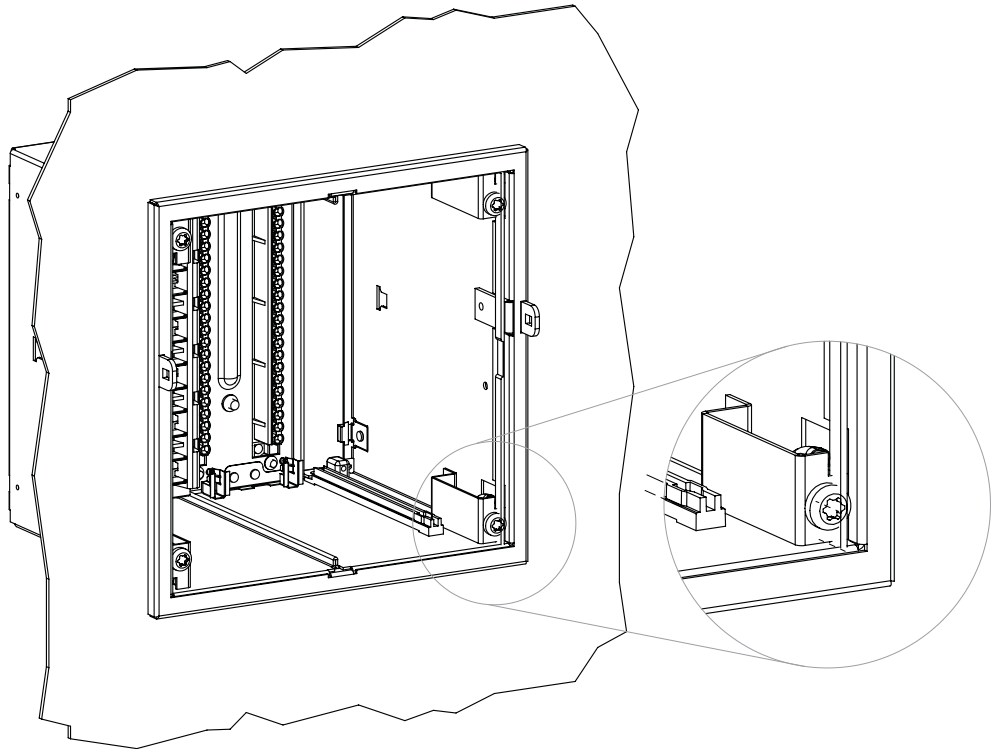

Figure 4: Flush mounted case, tightening the screws

4. Install the plug-in unit into the case.

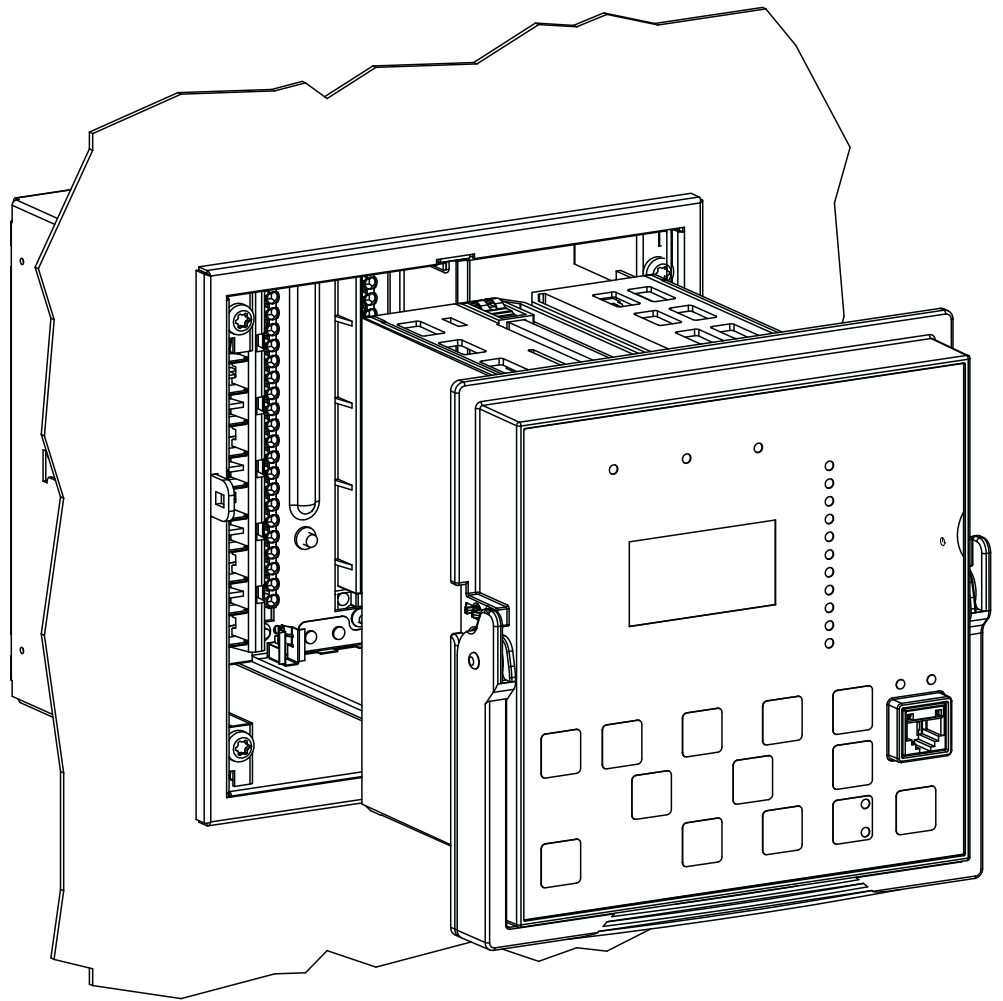

Figure 5: Flush mounting a plug-in unit into the case

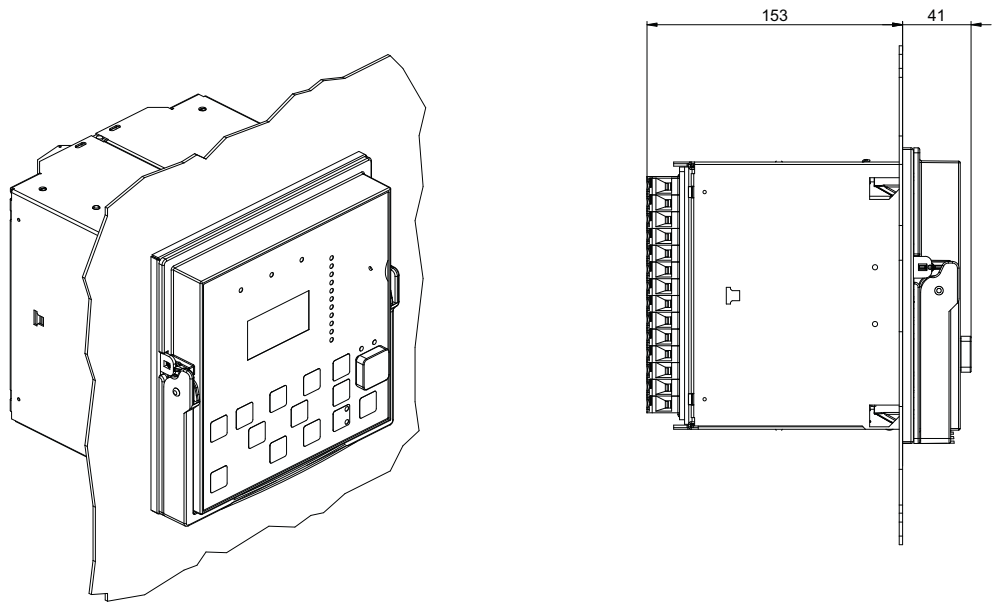

Figure 6: Flush mounted case and plug-in unit

4.3.2

Semi-flush mounting the IED

A mounting kit is needed for semi-flush mounting the IED. The mounting kit includes:

- Raising frame
- Gasket
- Screws
- Detailed mounting instructions

Requirements for installation:

- Panel cut-out of 165,5 x 161,5 mm with mounting holes
- Depth behind the panel 103 mm
- When IP 54 degree of protection (according to IEC 60529) is required for the front side, a gasket has to be used in the installation.

To semi-flush mount the IED:

1. Mount the raising frame into the panel cut-out with four M4 screws.

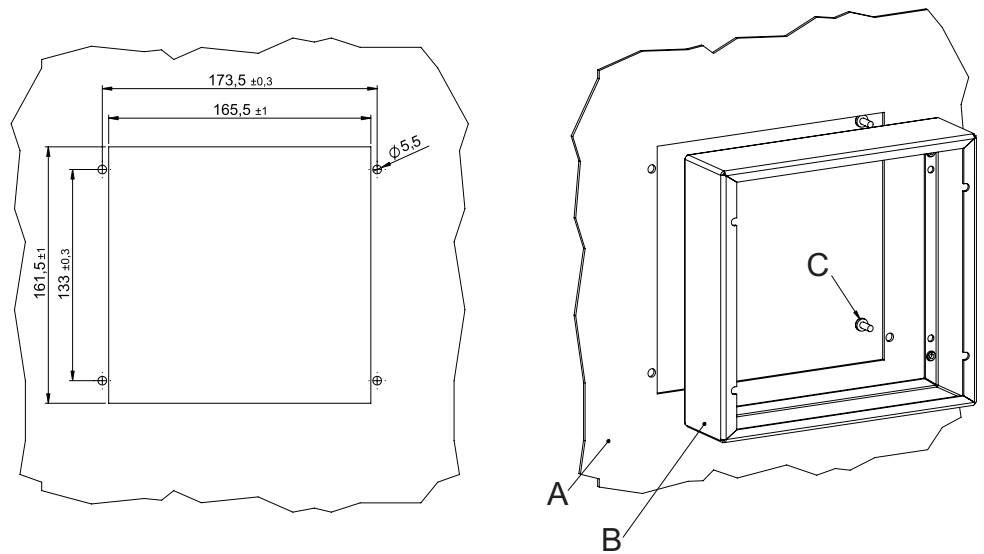

Figure 7: Mounting the raising frame

- A) Panel
- B) Raising frame
- C) M4 screw

2. Loosen the four M5 fixing screws into the case to fit the case to the raising frame.
3. Mount the case to the panel cut-out.

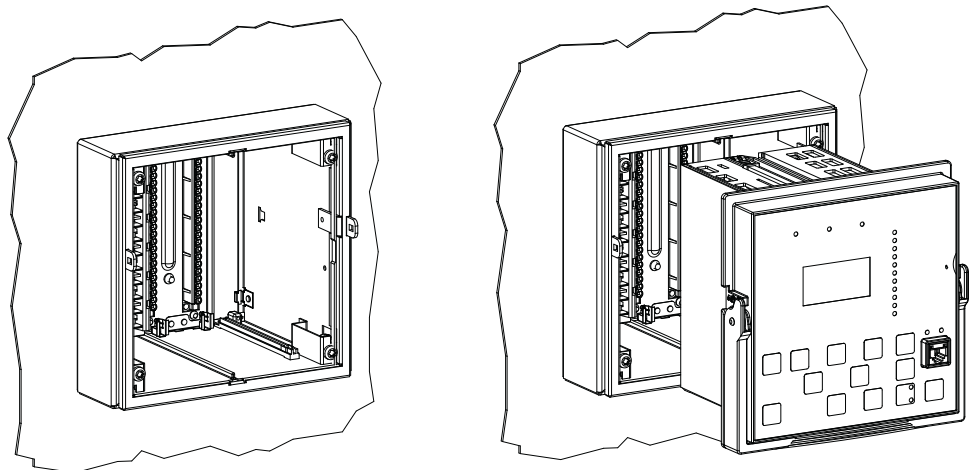

Figure 8: Mounting the case

4. Tighten the M5 screws.
The allowed range for the fixing screws' tightening torque is 0.7...1 Nm.

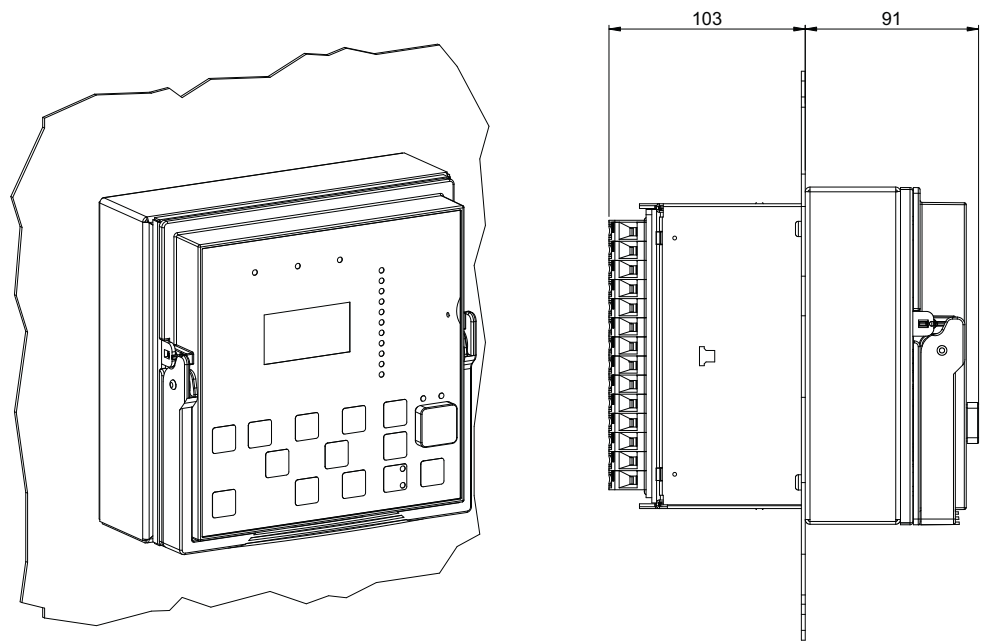

Figure 9: Semi-flush mounted IED

4.3.3

Semi-flush mounting the IED inclined

A mounting kit is needed for semi-flush mounting the IED inclined. In addition to the detailed mounting instructions, the mounting kit includes:

- Angle frame
- Gasket
- Screws

Requirements for installation:

- Panel cut-out of 167 x 203 mm with mounting holes
- Depth behind the panel 107 mm
- When IP 54 degree of protection (according to IEC 60529) is required for the front side, a gasket has to be used in the installation.

To semi-flush mount the IED inclined:

1. Mount the angle frame into the panel cut-out with four M4 screws.

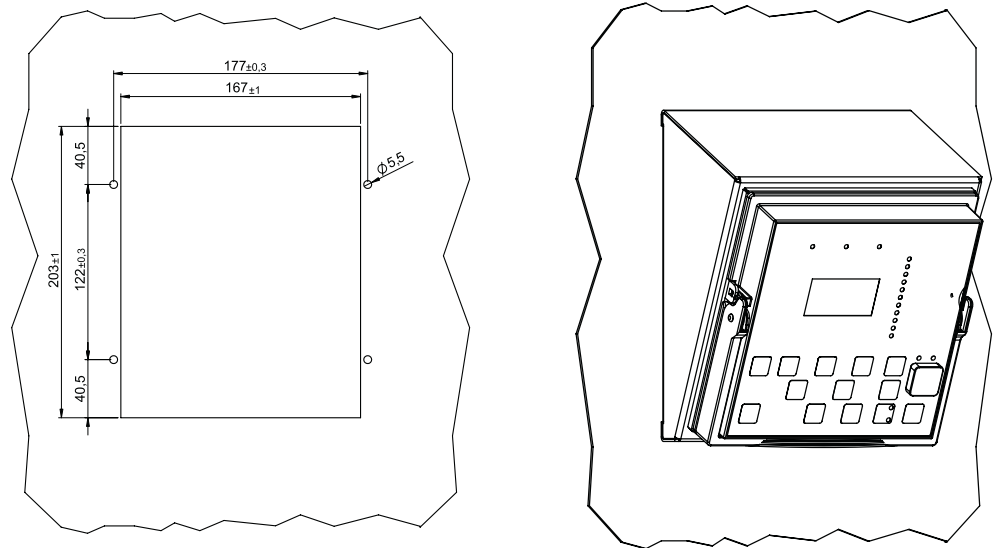

Figure 10: Mounting the angled frame

2. Loosen the four M5 fixing screws in the case to fit the case into the angle frame.
3. Mount the case to the panel cut-out.
With the angled frame, the IED can be mounted inclined downward to a 25° angle.
4. Tighten the screws.
The allowed range for the fixing screws' tightening torque is 0.7...1 Nm.

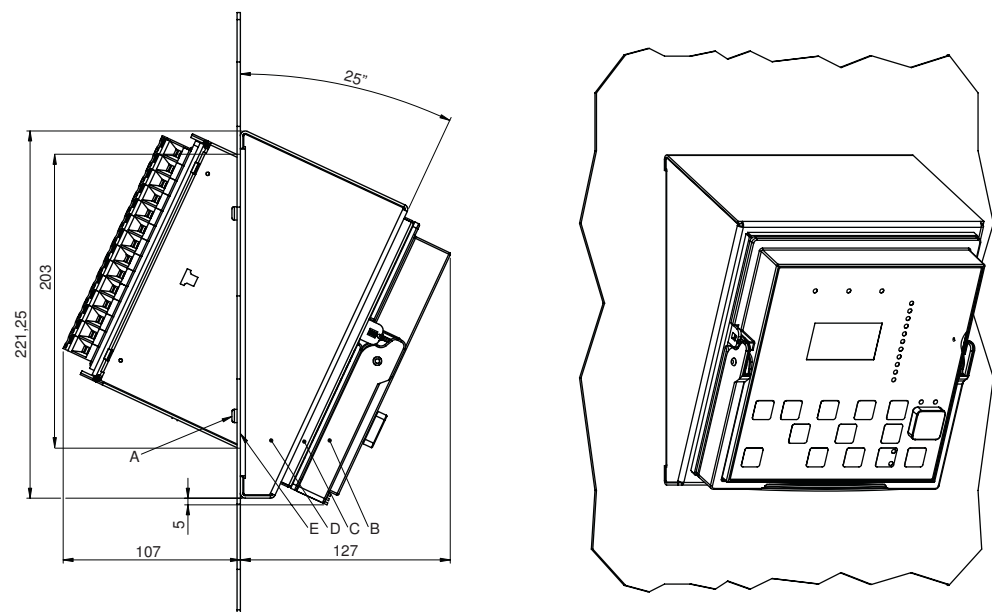

Figure 11: IED semi-flush mounted inclined

- A) M4 screws
- B) Plug-in unit

-
- C) Case
 - D) Angled frame
 - E) Gasket

4.3.4 Rack mounting the IED

A mounting kit is needed for rack mounting the IED. In addition to the detailed mounting instructions, the 19" rack mounting kit includes:

- Mounting panel; the type of the mounting panel depends on the number of mounted relays
- Screws

To rack mount the IED:

1. Mount the mounting panel to a 19" rack.
2. Loosen the four M5 fixing screws in the case to fit the case into the panel cut-out.
3. Mount the case to the panel cut-out.

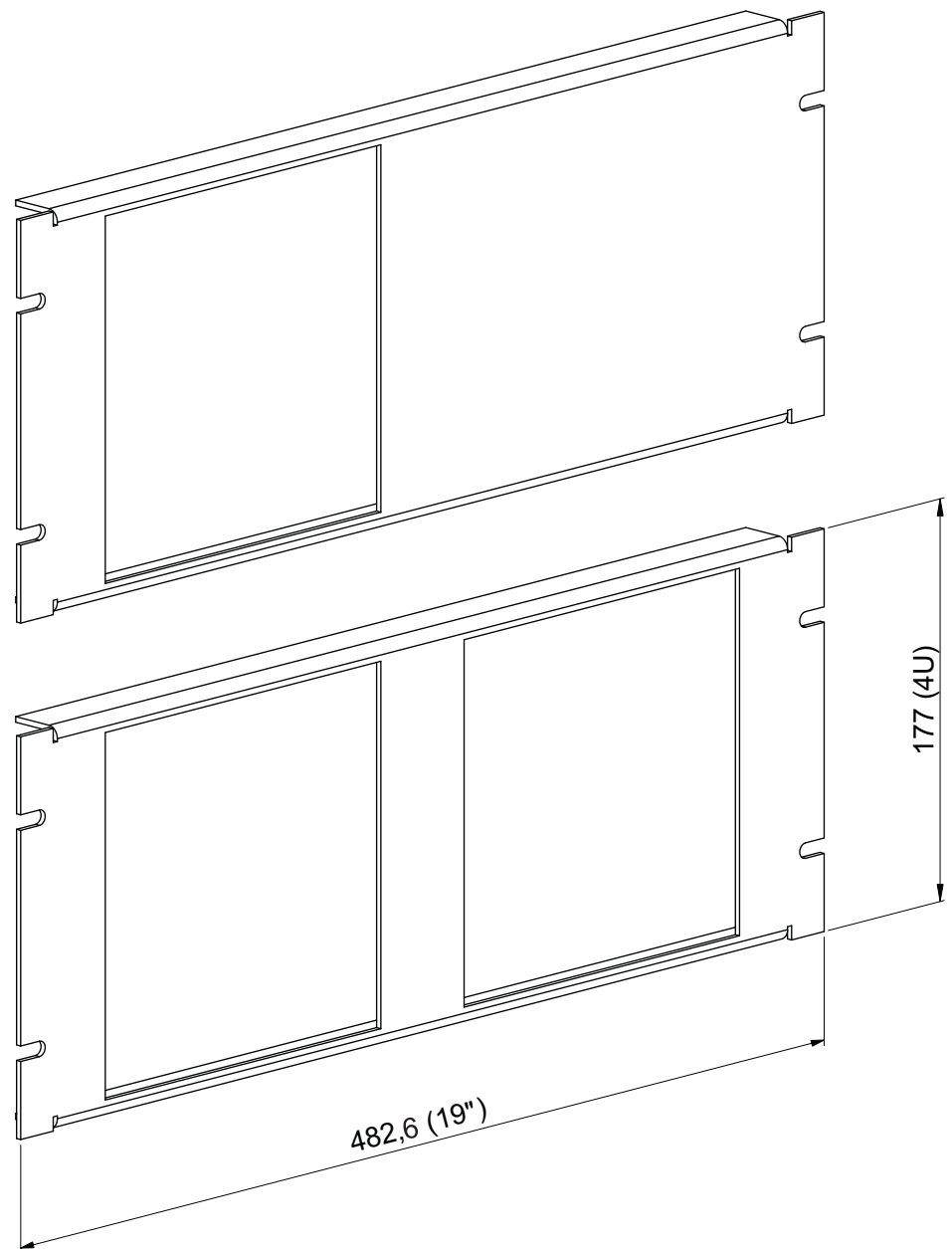

Figure 12: 19" rack mounting panels

4. Tighten the screws.
The allowed range for the fixing screws' tightening torque is 0.7...1 Nm.

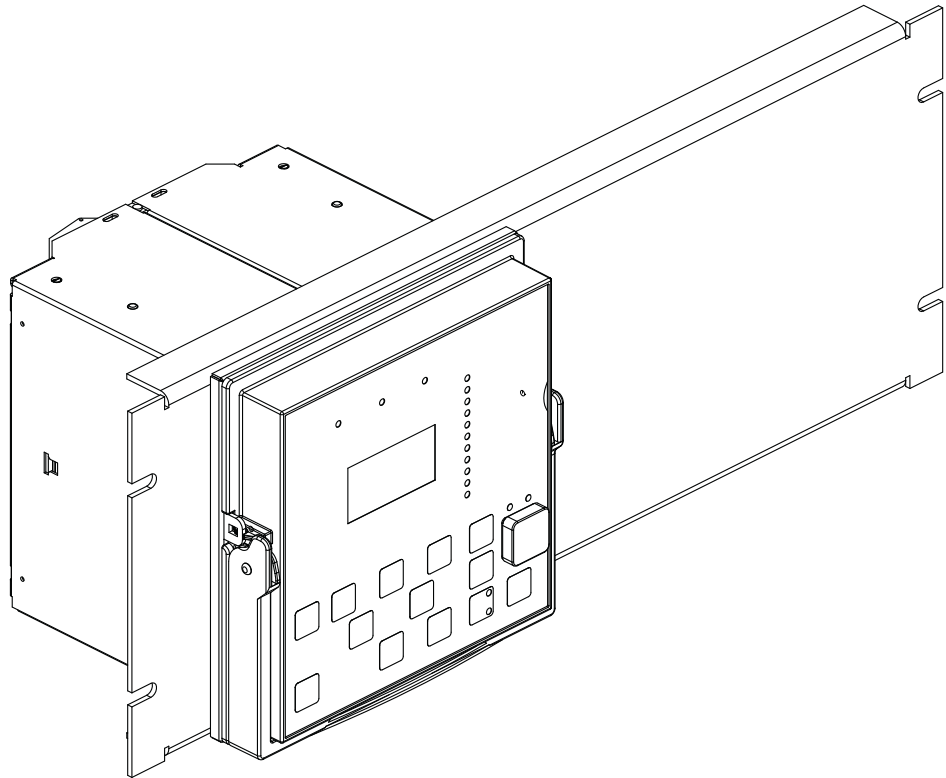

Figure 13: Rack mounted IED

4.3.5

Wall mounting the IED

A mounting kit is needed for wall mounting the IED. In addition to the detailed mounting instructions, the wall mounting kit includes:

- Wall mounting frame and rail parts
- Back plate
- Screws
- Dimensions for screw holes

To wall mount the IED:

1. Drill screw holes according to the dimensional drawing.
2. Mount the wall mounting frame and the rails.
3. Install the back plate.
4. Loosen the four M5 fixing screws in the case to fit the case into the mounting frame.
5. Mount the case between the rails.

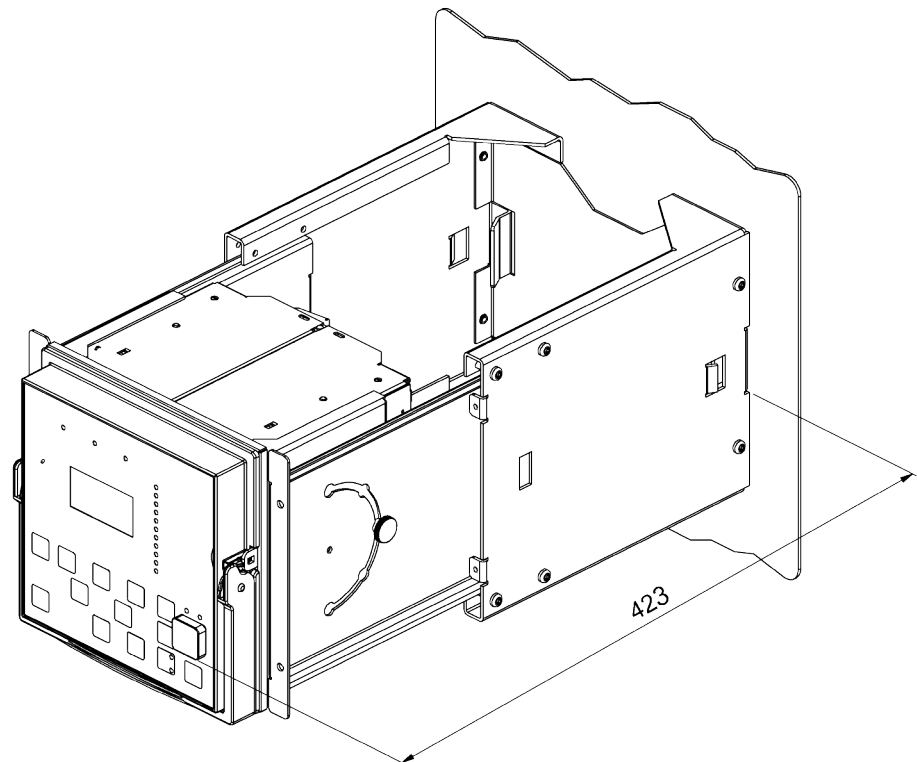

Figure 14: Wall mounting the IED

6. Tighten the screws.
The allowed range for the fixing screws' tightening torque is 0.7...1 Nm.

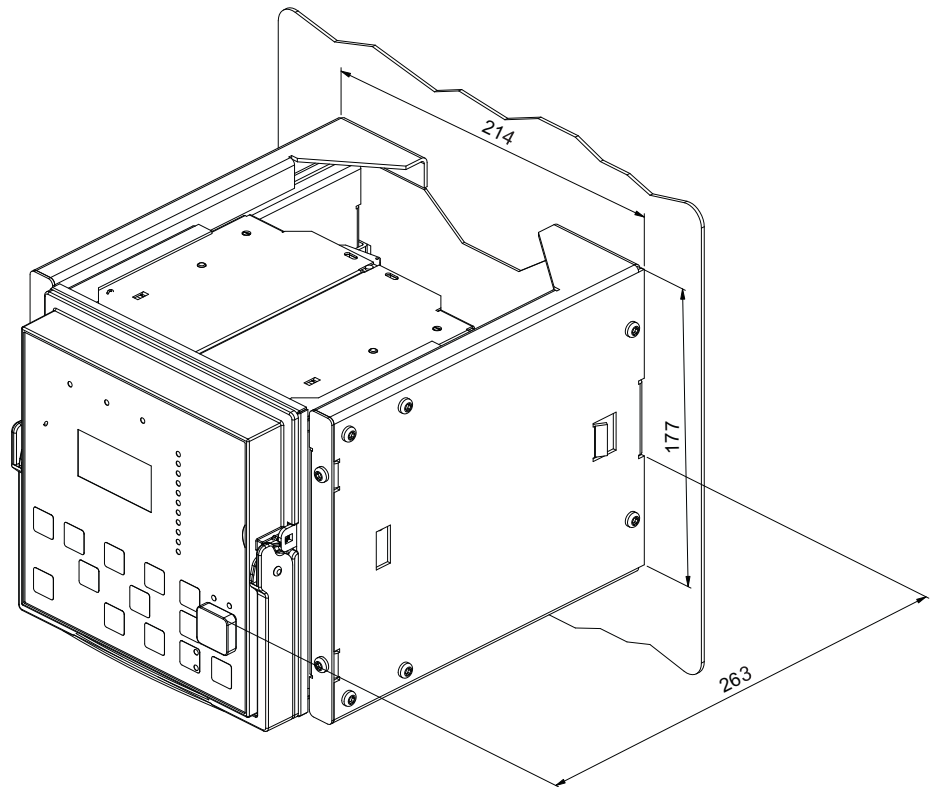

Figure 15: Wall mounted IED



Minimum of 50 mm space is needed between two kits.

When connecting the wires, a wall-mounted IED can be pulled out and turned 45° (or 90°) degrees downwards or upwards.

- To release the IED for pulling it out, push the locks beside the mounting frame.
- To rotate the IED, loosen the knurled-head screws in the rails.

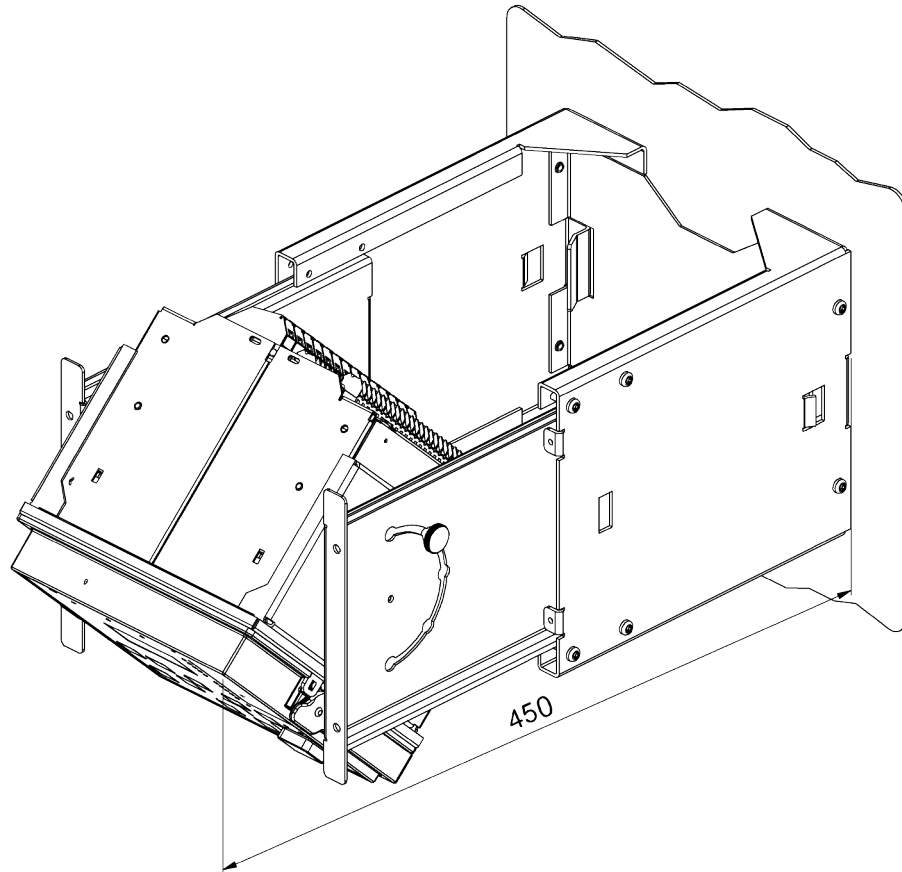

Figure 16: Wall mounted IED in rotated position



Minimum of 50 mm space is needed above and below the frame for rotating.

4.3.6

Rack mounting the IED and test switch RTXP to a 19" equipment frame

A mounting kit is needed for rack mounting the IED in a 19" equipment frame. In addition to the detailed mounting instructions, the mounting kit includes:

- Mounting panel
- Metallic frame for mounting the RTXP 18 test switch to the panel



An IED equipped with optic connections requires a minimum depth of 180 mm.

To rack mount the IED into a 19" equipment frame:

1. Mount the mounting panel into the 19" rack.
2. Loosen the four M5 fixing screws in the case to fit the case into the panel cut-out.
3. Mount the case to the panel cut-out.
4. Install the optional metallic frame to mount the RTXP 18 test switch to the panel.

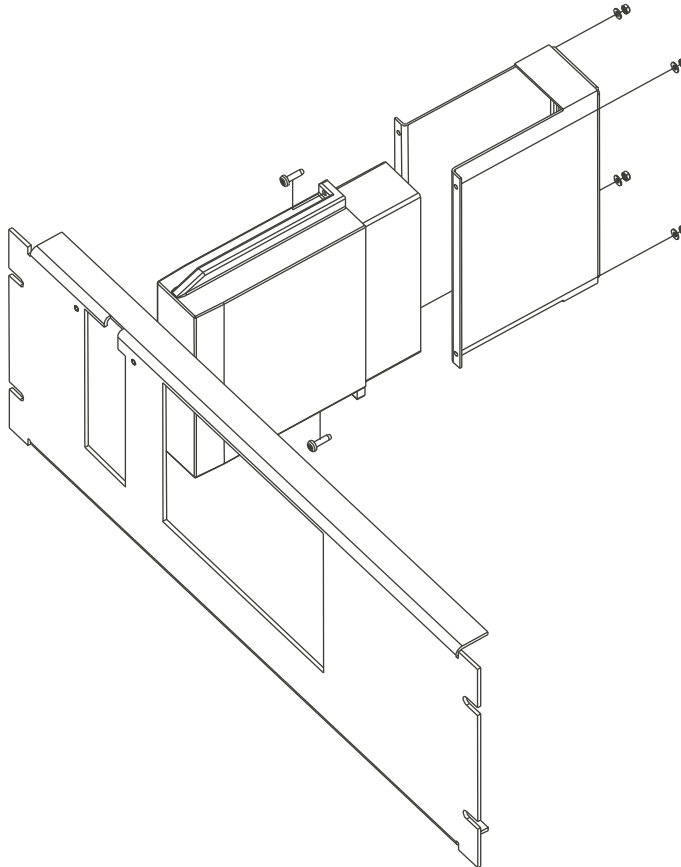

Figure 17: Mounting of the metallic frame for an RTXP 18 test switch

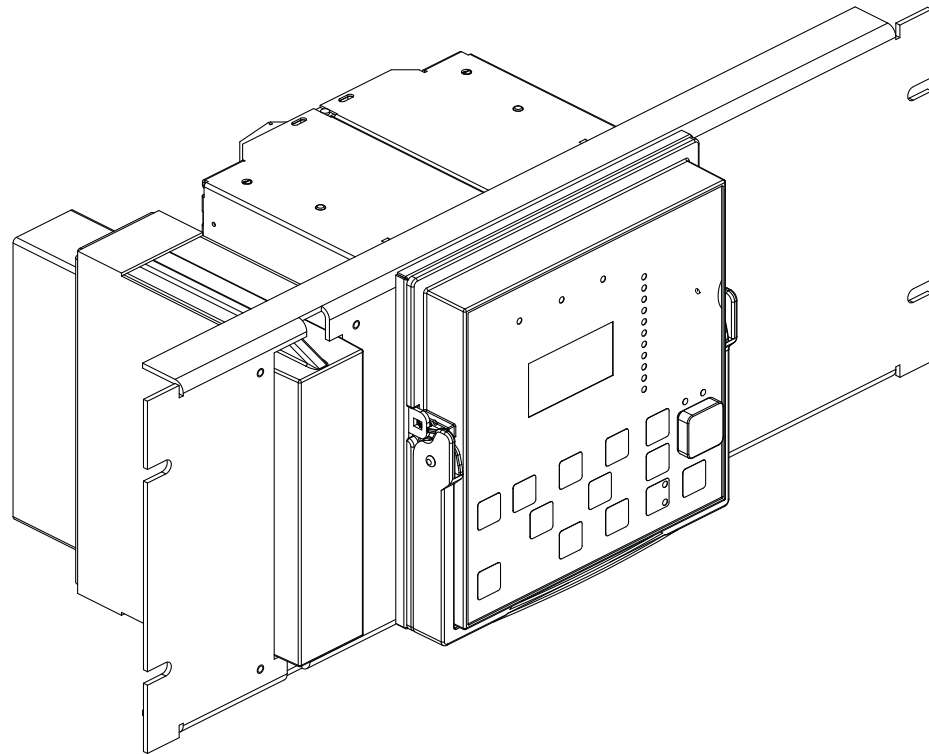

Figure 18: IED and the test switch RTXP 18 mounted into a 19" equipment panel

4.3.7

Rack mounting the IED in a combiflex 19" equipment frame

A mounting kit is needed for rack mounting the IED into a combiflex 19" equipment frame. In addition to the detailed mounting instructions, the mounting kit includes:

- Mounting brackets for the case
- Optional mounting brackets for RTXP 18 test switch

To rack mount the IED into a combiflex 19" equipment frame:

1. Mount the mounting brackets to the case by using the M5 fixing screws. The case contains all the needed mounting accessories.



The type of mounting brackets to be used depends on whether the IED is installed into the frame on its own or with a test switch.

2. Mount the case into the 19" equipment frame.

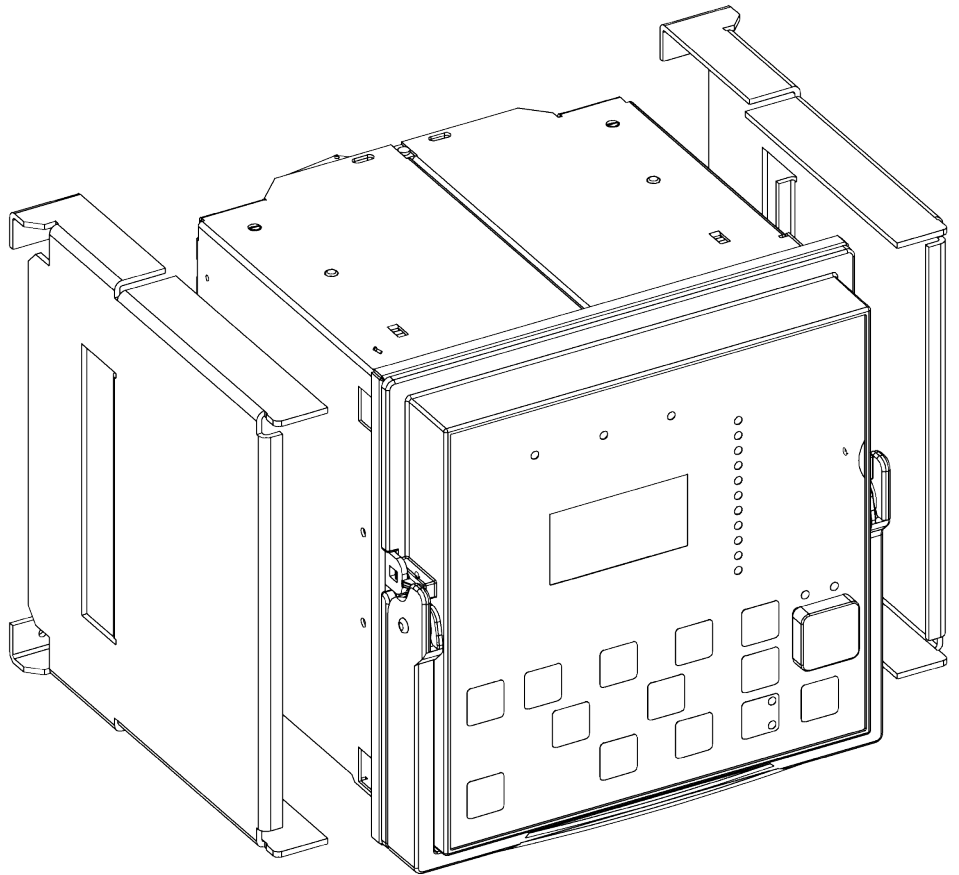

Figure 19: Mounting the IED into a 19" combiflex equipment frame

3. Install the optional RTXP 18 test switch.
With a separate mounting kit, the IED can be mounted into a 19" rack together with an RTXP 18 test switch.

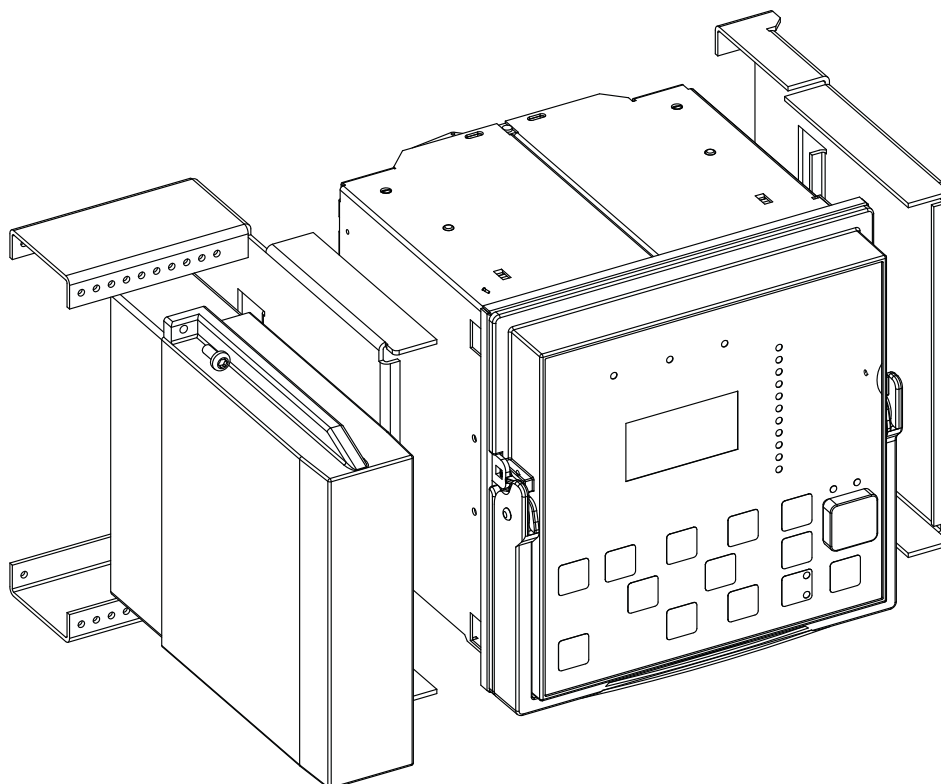

Figure 20: IED and the test switch

4.3.8 Mounting lens sensors for an arc protection system

Arc protection is used to detect arc situations in air insulated metal-clad switchgear.

The arc protection system determines where in the switchgear cubicle the optional lens sensors are installed. See the application examples in the Application Manual for further information on the alternatives.

To mount the lens sensor:

1. Drill a hole (\varnothing 10 mm) in the wall of the supervised space.

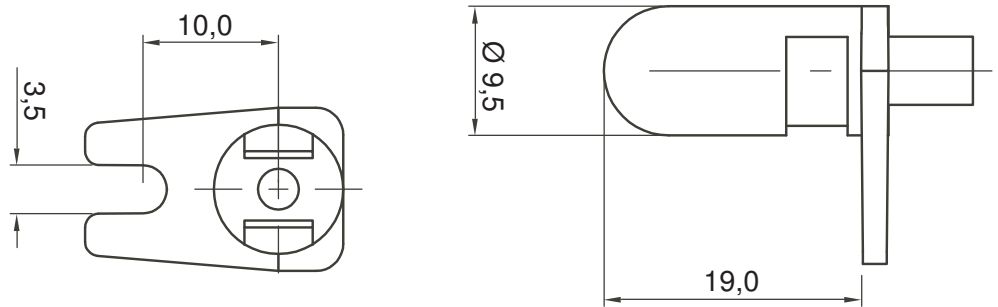

Figure 21: Dimensions of the lens sensor

2. Fit the lens sensor into the hole and fasten it with a self-tapping M3 screw. Alternatively, the lens sensor can be fastened with a cable tie. To do this, secure the cable tie to a suitable point of attachment on the cubicle wall and wrap the cable tie tightly around the sensor.

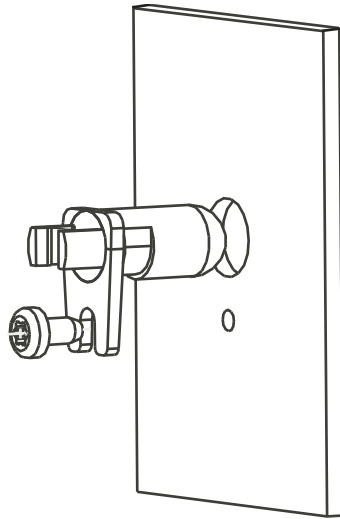

Figure 22: Mounting the lens sensor

3. Make sure that the cable tie lies in the groove of the sensor to prevent it from blocking the light.

Section 5 Connecting

5.1 Required tools

Only use a screwdriver and insert bits for Phillips (PH 1) cross-recessed head screws (M3.5) when handling CT/VT terminals (X2.1) of screw-compression type.

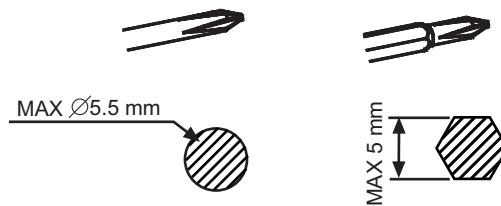

Figure 23: Screwdriver for CT/VT terminals of screw-compression type

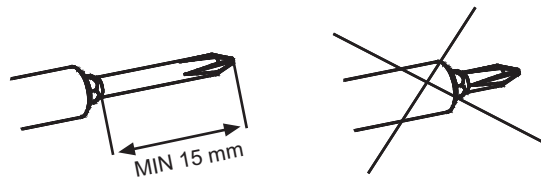

Figure 24: Insert bits for CT/VT terminals of screw-compression type

5.2 Connecting wires

All connections are made on the rear of the case. No soldering is needed.



Use fine wire in door mounting.



See the Technical Manual for product-specific connection diagrams.

When connecting wires:

- Connect each signal connector (X100, X110 and X130) terminal with one 0.5...2.5 mm² wire or with two 0.5...1.0 mm² wires.
- Connect signal connector X120 with one of maximum 2.5 mm² wire.
- Connect each ring-lug terminal for CTs/VTs with one 0.5...6.0 mm² wire or with two of maximum 2.5 mm² wires.
- Connect terminals on the optional communication modules for RS-485 with one 0.08...1.5 mm² wire or with two of maximum 0.75 mm² wires.

5.2.1 Connecting ring-lug type wires

Ring-lug type insulated terminal can be used for signal connector X120. The maximum outside diameter for the M4 ring-lug type terminals is 9 mm.

5.3 Connecting protective earthing



The earth lead must be at least 4.0 mm². If the length of the earth lead is long, the cross section of the wire must be increased.



Use fine copper wire as the earth lead.

To connect a separate earth protection lead:

1. Loosen the protective earth screw to connect the earth lead.

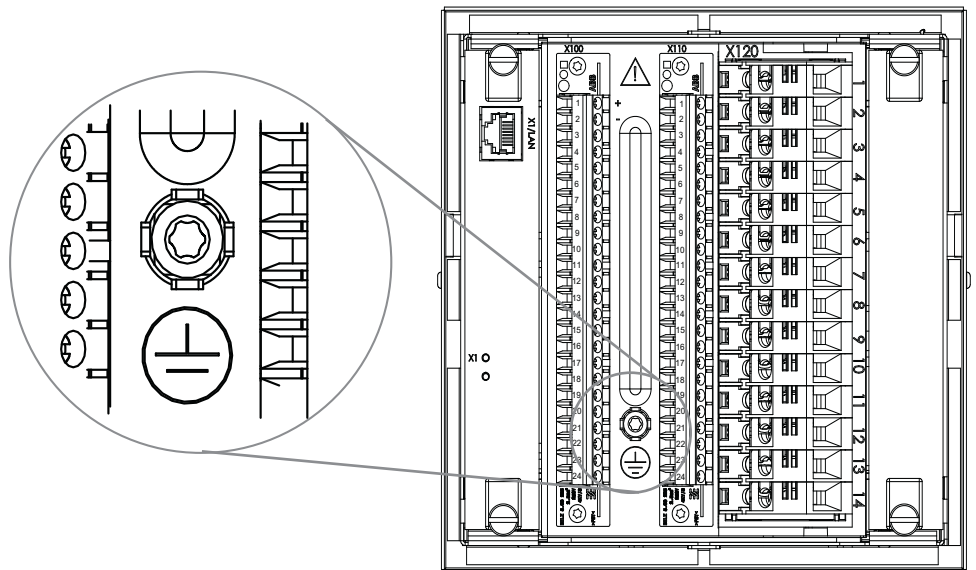

Figure 25: The protective earth screw is located between connectors X100 and X110



The earth lead should be as short as possible but notice that extra length is required for door mounting.



Each IED must have its own earth lead connected to the earth circuit connector.

2. Connect the earth lead to the earth bar.
Use either stripped wire screwed between a washer cup and the protective earth screw or a ring-lug.



Select a suitable ring-lug to fit under the M4 screw.

3. Tighten the protective earth screw.
4. Support the earth lead so that it cannot break or weaken.
Observe the situations for mechanical, chemical or electrochemical reasons.

5.4 Connecting analog signals

A connection diagram is needed to connect the analog signals.

Use the ring-lug type for CT/VT terminals.

1. Open the lid that covers the ring-lug fixing screw with the tip of a screwdriver (every fixing screw has its own lid).
2. Remove the screw, slide it through the terminal lug and screw it back on.
3. Close the lid.

5.4.1

Connecting current and voltage inputs

Connect the wires from the CTs/VTs to the correct device according to the phase order and the connection diagram. Each terminal for CTs/VTs is dimensioned for one 0.5...6.0 mm² wire or for two wires of maximum 2.5 mm².



See the specific card variants from the Application Manual.

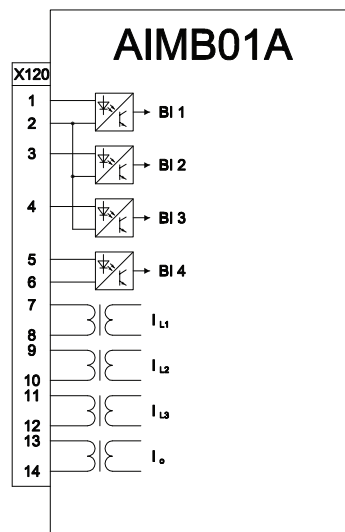

Figure 26: Example of AIMB01A card variant (4 I with 1/5 A I_o channel)

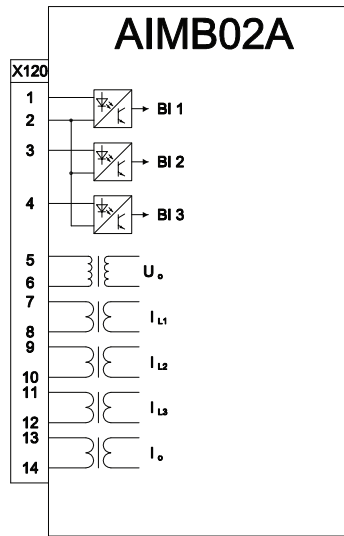

Figure 27: Example of AIMB02A card variant (4 I + U_o with 1/5 A I_o channel)

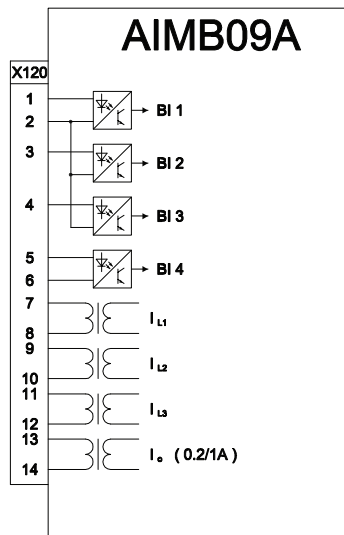

Figure 28: Example of AIMB09A card variant (4 I with 0.2/1 A I_o channel)

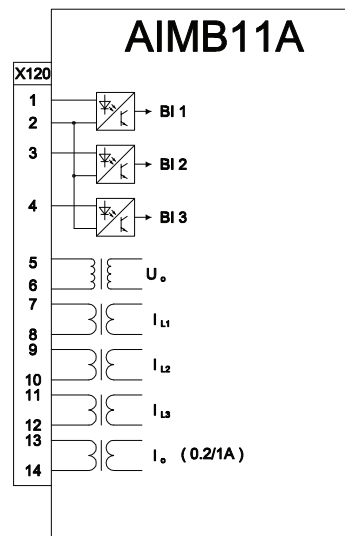

Figure 29: Example of AIMB11A card variant (4 I + Uo with 0.2/1 A Io channel)

5.4.2 Connecting IED with test switches

If the IED is delivered with test switches, connect the current and voltage transformers directly to the switches.

5.5 Connecting power supply

The IED's auxiliary voltage is connected to terminals X100-1 and X100-2. At DC supply, the positive lead is connected to terminal X100-1. The permitted auxiliary voltage range of the IED is marked on top of the IED's LHMI.

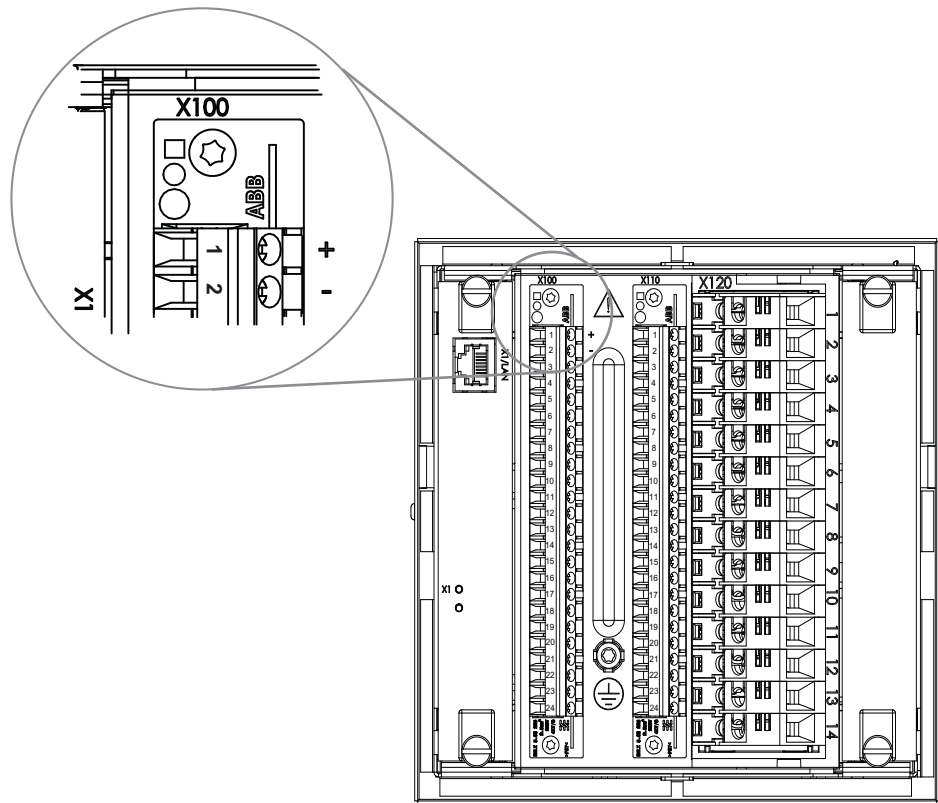

Figure 30: Connecting auxiliary voltage

5.6 Connecting communication

Before connecting communication, check that the HW module has the correct communication interfaces. The communication module is located on the left side of the IED when viewing the case from the rear.



See the Technical Manual for product-specific communication interfaces.

5.7 Energizing the IED

During the start-up all LEDs are lit for a short period.

-
- Green Ready LED starts to blink
 - LCD lights up and IED start-up is displayed
 - The main menu is displayed. A steady green Ready LED indicates a successful start-up.

If the self-supervision of the IED notices problems during the start-up, the green Ready LED blinks and the internal fault code is displayed on the LCD.

Section 6 De-installing, repairing and exchanging

6.1 Product lifecycle





In the product lifecycle, there is going to be a time to upgrade the IED to a next generation unit. Even though this is relevant after some 20 years from the installation, it is wise to already consider the product lifecycle when investing on the original product.

Protection IED specific options can be found from Retrofit Solutions Database on the Internet www.abb.com by following the links within ABB Service Guide or via ABB Product Guide from the product specific Service & Support sheet.

6.2 Checking IED information

The IED information includes detailed information about the device, such as version and serial number. The IED information is shown on the display for a few seconds when the device starts up. The same information is found also in the IED menu.

To view the device information:

1. Select **Main Menu/Information**.
2. Select a submenu with  and .
3. Enter the selected submenu with .
4. Browse the information with  and .

The **Product identifiers** submenu contains product related information like product type, serial number, order number, production date, configuration name, SW version, SW date and HW revision.

The **Site identifiers** submenu contains information about the site where the IED has been installed.

The **HW modules** submenu contains information about the HW modules.

The **System identifiers** submenu contains the unique IED name which cannot be changed.

6.3 De-installing the IED

To de-install the IED:

1. Turn off the power.
2. Detach the IED from the case.
3. Disconnect the wiring.
4. Loosen the four M5 fixing screws.

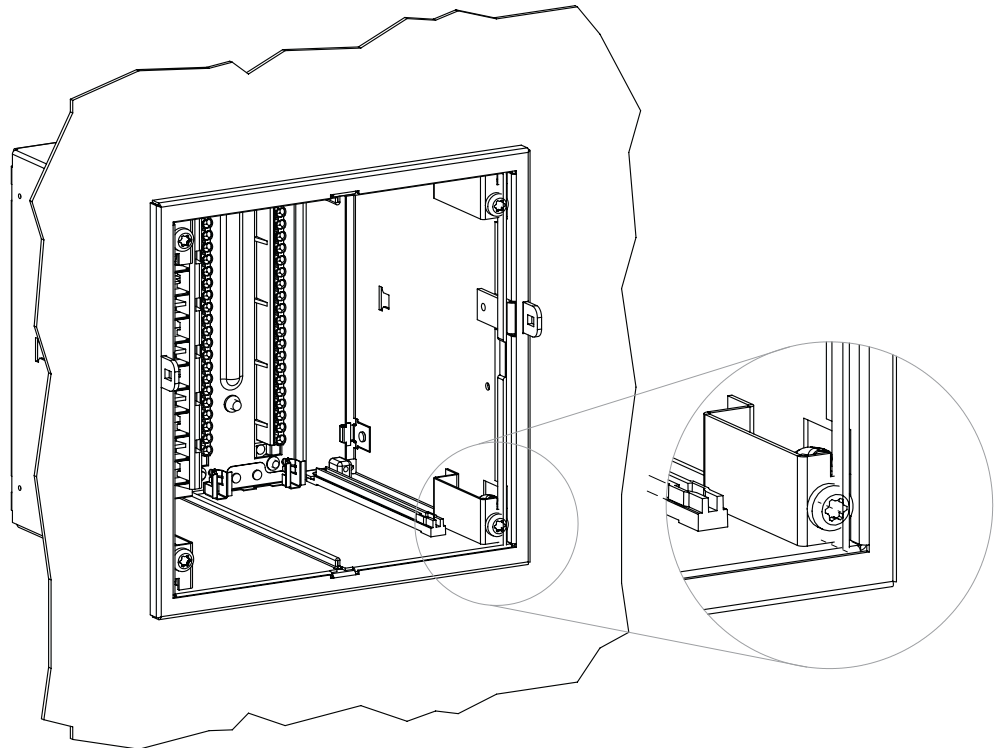

5. Detach the case from the panel cut-out.

6.4 Sending the IED for repair

In case of product problems, contact the nearest ABB or representative for consulting and instructions.

6.5 Exchanging the IED

To exchange the IED with another identical unit, de-install the IED and install the new one. The exchangeable units can be found from the PartsOnLine system, see www.abb.com/partsonline.

To exchange an IED to a different unit, change the case and connect the wires.



The IED HW and SW can be modified or upgraded.

Section 7 Technical data

7.1 Case and HMI display variants

7.1.1 Front side of the IED

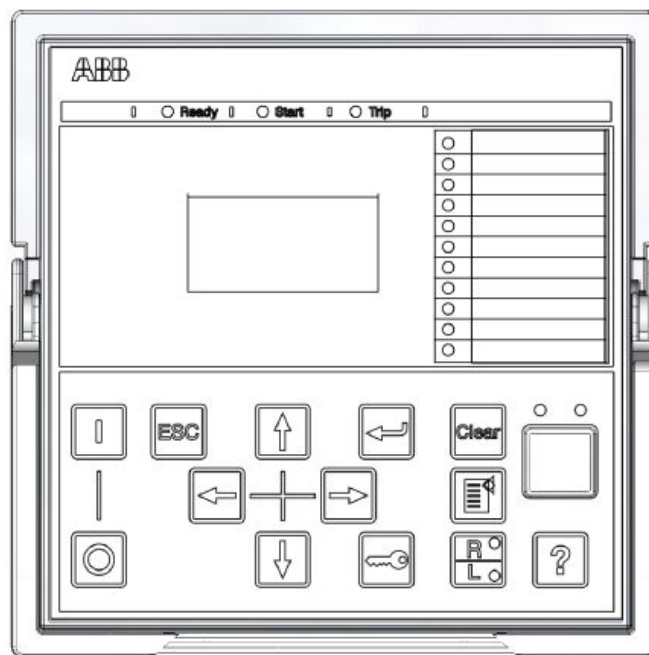

Figure 31: Small display



Figure 32: Large display

Table 3: Small display

Character size ¹⁾	Rows in the view	Characters per row
Small, mono-spaced (6x12 pixels)	5	20
Large, variable width (13x14 pixels)	4	8 or more ¹⁾

1) Depending on the selected language

Table 4: Large display

Character size ¹⁾	Rows in the view	Characters per row
Small, mono-spaced (6x12 pixels)	10	20
Large, variable width (13x14 pixels)	8	8 or more ¹⁾

7.1.2 Rear side of the IED

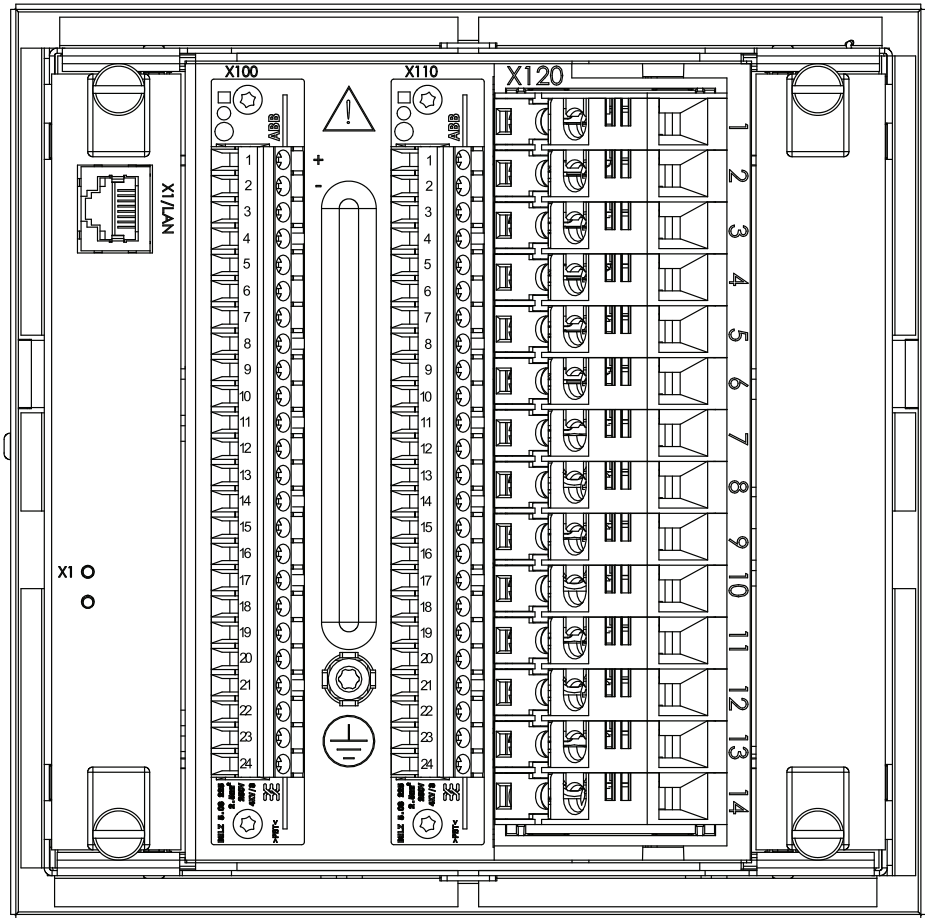

Figure 33: Rear view of RE_615 with communication module

7.2 Dimensions

Table 5: Dimensions of the IED

Width	frame	177 mm
	case	164 mm
Height	frame	177 mm (4U)
	case	160 mm
Depth	case	155 mm
Weight	IED	3.5 kg
	spare unit	1.8 kg

7.2.1 Mounting dimensions

Table 6: *Flush mounted*

Dimension	Value	
Width	case	165.5 mm
Height	case	161.5 mm
Depth	case	153 mm

Table 7: *Semi-flush mounted*

Dimension	Value	
Width	case	165.5 mm
Height	case	161.5 mm
Depth	case	103 mm

Table 8: *Semi-flush mounted inclined*

Dimension	Value	
Width	case	203 mm
Height	case	167 mm
Depth	case	107 mm

Table 9: *Wall mounted dimensions*

Dimension	Value	
Width	case	214 mm
Depth	case in normal position	263 mm
Depth	case pulled-out position	423 mm
Height	case in normal position	177 mm
Height	case inclined 45° degrees	187 mm

7.3 Inputs and outputs

7.3.1 Power supply

Table 10: Power supply

Type	Type 1	Type 2 ¹⁾
U _{aux} nominal	100, 110, 120, 220, 240 V AC, 50 and 60 Hz	24, 30, 48, 60 V DC
	48, 60, 110, 125, 220, 250 V DC	
U _{aux} variation	38...110% of U _n (38...264 V AC)	50...120% of U _n (12...72 V DC)
	80...120% of U _n (38.4...300 V DC)	
Start-up threshold		19.2 V DC (24 V DC * 80%)
Burden of auxiliary voltage supply under quiescent (P _q)/operating condition	<8.4 W/13 W ²⁾	
Ripple in the DC auxiliary voltage	Max 12% of the DC value (at frequency of 100 Hz)	
Maximum interruption time in the auxiliary DC voltage without resetting the relay	50 ms at U _{aux} rated	
Fuse type	T4A/250 V	

1) Not available in RED615

2) In RED615, <8.8 W/16,1 W

7.3.2

Energizing inputs

Table 11: Energizing inputs

Rated frequency		50/60 Hz ± 5 Hz		
Current inputs	Rated current, I _n	0.2/1 A ¹⁾²⁾	1/5 A ³⁾	
	Thermal withstand capability:	• Continuously	4 A ²⁾	20 A
		• For 1 s	100 A ²⁾	500 A
		• For 10 s	25 A ²⁾	100 A
	Dynamic current withstand:	• Half-wave value	250 A ²⁾	1250 A
		Input impedance	<100 mΩ ²⁾	<20 mΩ
Voltage input	Rated voltage	100 V/ 110 V/ 115 V/ 120 V (Parametrization)		
	Voltage withstand:	• Continuous	2 x U _n (240 V)	
		• For 10 s	3 x U _n (360 V)	
	Burden at rated voltage	<0.05 VA		

1) Residual current

2) Not available in RED615

3) Phase currents

7.3.3 Binary inputs

Table 12: *Binary inputs*

Description	Value
Operating range	±20% of the rated voltage
Rated voltage	24...250 V DC
Current drain	2...18 mA
Power consumption/input	<0.9 W
Threshold voltage	18...176 V DC

7.3.4 Signal outputs

Table 13: *Signal output and IRF output*

Description	Value
Rated voltage	250 V AC/DC
Continuous contact carry	5 A
Make and carry for 3.0 s	10 A
Make and carry 0.5 s	15 A
Breaking capacity when the control-circuit time constant L/R<40 ms	1 A/0.25 A/0.15 A
Minimum contact load	100 mA at 24 V AC/DC

Table 14: *Signal output X100: SO1*

Description	Value
Rated voltage	250 V AC/DC
Continuous contact carry	5 A
Make and carry for 3.0 s	15 A
Make and carry 0.5 s	30 A
Breaking capacity when the control-circuit time constant L/R<40 ms	1 A/0.25 A/0.15 A
Minimum contact load	100 mA at 24 V AC/DC

7.3.5 Power outputs

Table 15: *Double-pole power output relays with TCS function*

Description	Value
Rated voltage	250 V AC/DC
Continuous contact carry	8 A
Make and carry for 3.0 s	15 A
Make and carry for 0.5 s	30 A
Breaking capacity when the control-circuit time constant L/R<40 ms, at 48/110/220 V DC (two contacts connected in series)	5 A/3 A/1 A
Minimum contact load	100 mA at 24 V AC/DC
Trip-circuit supervision (TCS):	
• Control voltage range	20...250 V AC/DC
• Current drain through the supervision circuit	~1.5 mA
• Minimum voltage over the TCS contact	20 V AC/DC (15...20 V)

Table 16: *Single-pole power output relays*

Description	Value
Rated voltage	250 V AC/DC
Continuous contact carry	8 A
Make and carry for 3.0 s	15 A
Make and carry for 0.5 s	30 A
Breaking capacity when the control-circuit time constant L/R<40 ms, at 48/110/220 V DC	5 A/3 A/1 A
Minimum contact load	100 mA at 24 V AC/DC

7.3.6

Data communication for front interface

Front interface:

- TCP/IP protocol
- Standard CAT 5 Ethernet cable
- 10 MBits/s

7.4

Installation definitions

7.4.1

Lens sensor and optic fibre for arc protection

Table 17: *Lens sensor and optic fibre for arc protection*

Description	Value
Fibre-optic cable including lens	1.5 m, 3.0 m or 5.0 m
Normal service temperature range of the lens	-40...+100 °C
Maximum service temperature range of the lens, max 1 h	+140°C
Minimum permissible bending radius of the connection fibre	100 mm

7.4.2 Enclosure class

Table 18: *Degree of protection of flush-mounted IED*

Description	Value
Front side	IP 54
Rear side, connection terminals	IP 20

7.4.3 Environmental conditions and tests

Table 19: *Environmental conditions*

Description	Value
Operating temperature range	-25...+55°C (continuous)
Short-time service temperature range	-40...+85°C (<16h) ¹⁾ Note: Degradation in MTBF and HMI performance outside the temperature range of -25...+55°C
Relative humidity	<93%, non-condensing
Atmospheric pressure	86...106 kPa
Altitude	up to 2000 m
Transport and storage temperature range	-40...+85°C

1) For RED615, -40...+70°C (<16h)

Table 20: Environmental tests

Description	Value
Dry heat test (humidity <50%)	According to IEC 60068-2-2 Test values: <ul style="list-style-type: none"> • 96 h at +55°C • 16 h at +85°C
Cold test	According to IEC 60068-2-1 Test values: <ul style="list-style-type: none"> • 96 h at -25°C • 16 h at -40°C
Damp heat test, cyclic	According to IEC 60068-2-30 Test values: <ul style="list-style-type: none"> • 6 cycles at +25...55°C, humidity 93...95%
Storage test	According to IEC 60068-2-48 Test values: <ul style="list-style-type: none"> • 96 h at -40°C • 96 h at +85°C

Section 8 Accessories and ordering data

Table 21: Accessories and ordering data

Item	Order number
Cables	
Cable for optical sensors for arc protection 1.5 m	1MRS120534-1.5
Cable for optical sensors for arc protection 3.0 m	1MRS120534-3.0
Cable for optical sensors for arc protection 5.0 m	1MRS120534-5.0
Mounting accessories	
Semi-flush mounting kit	1MRS050696
Wall mounting kit	1MRS050697
Inclined semi-flush mounting kit	1MRS050831
19" rack mounting kit with cut out for one IED	1MRS050694
19" rack mounting kit with cut out for two IEDs	1MRS050695
Mounting kit for RTXP 18 (4U Combiflex)	1MRS051010
Mounting kit for 4U high Combiflex equipment frame	1MRS050779
Test switches	
Mounting kit for 19" rack, single IED, including test switch RTXP 18	1MRS050783

Section 9 Glossary

CT	Current transformer
EMC	Electromagnetic compatibility
IEC	International Electrotechnical Commission
IED	Intelligent Electronic Device
LCD	Liquid crystal display
LCP	Liquid crystal polymer
LED	Light-emitting diode
LHMI	Local Human-Machine Interface
LON	Local operating network
PA	Polyamide
PBT	Polybutylene terephthalate
PC	Personal Computer; Polycarbonate
RoHS	Restriction of the use of certain Hazardous Substances in electrical and electronic equipment.
TCS	Trip-circuit supervision
WHMI	Web Human-Machine Interface



ABB Oy
Distribution Automation
P.O. Box 699
FI-65101 VAASA, Finland
Phone +358 10 22 11
Fax +358 10 22 41094
www.abb.com/substationautomation