

# Combined Overcurrent and Earth-fault Relay

# SPAJ 135 C

## Product Guide





## Features

- Two-stage phase overcurrent protection and single-stage earth-fault protection in one relay
- Two-phase low-set definite time or inverse time (IDMT) overcurrent stage
- Two-phase high-set instantaneous or definite time overcurrent stage
- Non-directional definite time or inverse time (IDMT) earth-fault stage
- Fully field-configurable output relay functions
- Flexible matching of the relay to a variety of protection applications
- Numerical display of setting values, measured values, recorded fault values, indications, etc.
- Built-in pulse-width-modulated galvanically isolating power unit for a wide range of auxiliary voltages
- Serial interface for bus connection module and fibre-optic substation bus
- Continuous self-supervision of relay hardware and software for enhanced system reliability and availability
- Auto-diagnostic fault indication to facilitate repair of a permanent internal relay fault

## Application

The combined phase overcurrent and earth-fault relay SPAJ 135 C is intended to be used for time and current graded overcurrent and earth-fault protection in distribution networks. The relay is especially suited for use in solidly earthed and low-resistance earthed networks.

The relay provides a two-phase non-directional overcurrent protection and non-directional earth-fault protection. The two-stage

overcurrent unit includes a low-set stage  $I_{>}$  and a high-set stage  $I_{>>}$ . The low-set stage  $I_{>}$  features field-selectable definite time characteristic or inverse definite minimum time (IDMT) characteristic as per IEC 255. The high-set stage  $I_{>>}$  operates either instantaneously or has a definite time characteristic. The earth-fault unit  $I_0$  also features field-selectable definite time characteristic or inverse definite minimum time (IDMT) characteristic as per IEC 255.

## Design

The combined overcurrent and earth-fault relay SPAJ 135 C is a secondary relay that is connected to the current transformers of the object to be protected. The earth-fault current can be measured either via a set of three phase current transformers in a residual current connection or a window-type core-balance current transformer. The relay measures two phase currents and residual current. When a phase overcurrent fault or an earth-fault occurs, the relay operates according to the configuration it has been given.

If one of the phase currents, or both, exceed the set start value  $I_{>}$  of the low-set stage, the overcurrent unit starts. When, at definite time mode of operation, the set operate time  $t_{>}$  or, at IDMT mode of operation, the calculated operate time, has expired, the overcurrent unit operates, delivering a trip signal TS1. In the same way the high-set stage starts, when its start value  $I_{>>}$  is exceeded and when the set operate time  $t_{>>}$  has expired, the relay operates, delivering a trip signal TS1.

The earth-fault unit operates in the same way. When the start value  $I_{0>}$  is exceeded the earth-fault unit starts and when, at definite time mode of operation, the set operate time  $t_{0>}$  or, at IDMT mode of operation, the calculated operate time, has expired, the earth-fault unit operates, delivering a trip signal TS2.

The low-set stage of the overcurrent unit and the earth-fault unit can be given either definite-time or inverse-time characteristic. At inverse time characteristic four inverse time curve sets with different slopes as per IEC 255 are available: Normal inverse, Very inverse, Extremely inverse and Long-time inverse.

The overcurrent and earth-fault relay is provided with two output relays for tripping and four output relays for signalling.

## Data communication

The relay is provided with a serial interface on the rear panel. By means of a bus connection module type SPA-ZC 17 or SPA-ZC 21 the relay can be connected to the fibre-optic SPA bus. The bus connection module type SPA-ZC 21 is powered from the host relay, whereas the bus connection module SPA-ZC 17 is provided with a built-in power unit, which can be fed from an external secured power source. The relay communicates with higher-level data acquisition and control systems over the SPA bus.

## Self-supervision

The relay incorporates a sophisticated self-supervision system with auto-diagnosis, which increases the availability of the relay and the reliability of the system. The self-supervision system continuously monitors the hardware and the software of the relay. The system also supervises the operation of the auxiliary supply module and the voltages generated by the module.

When the self-supervision system detects a permanent internal relay fault, the IRF indicator on the relay front panel is lit. At the same time the output relay of the self-supervision system operates and a fault message is transmitted to the higher-level system over the serial bus. Further, in most fault situations, a fault code is shown in the display of the protection relay module. The fault code indicates the type of the fault that has been detected.

## Auxiliary supply voltage

The auxiliary supply of the relay is obtained from an internal plug-in type power supply module. Two auxiliary power module versions are available: type SPTU 240S1 for the supply voltage range 80...265 V ac/dc and type SPTU 48S1 for the supply voltage range 18...80 V dc. The power supply module forms the internal voltages required by the protection relay and the I/O module.

**Technical data**

**Table 1: Energizing inputs**

Terminals		1-3, 7-9, 25-27	1-2, 7-8, 25-26
Rated current $I_n$		1 A	5 A
Thermal withstand capability	continuously	4 A	20 A
	for 10 s	25 A	100 A
	for 1 s	100 A	500 A
Dynamic current withstand capability	Half-wave value	250 A	1250 A
Input impedance		<100 m $\Omega$	<20 m $\Omega$
Rated frequency $f_n$ , according to order		50 Hz or 60 Hz	

**Table 2: Output contact ratings**

Type of contact		Tripping	Signalling
Terminals		65-66, 68-69	70-71-72, 74-75, 77-78, 80-81
Rated voltage		250 V ac/dc	
Thermal withstand capability	Carry continuously	5 A	5 A
	Make and carry for 0.5 s	30 A	10 A
	Make and carry for 3 s	15 A	8 A
Breaking capacity for dc, when the control/signalling circuit time constant $L/R \leq 40$ ms, at the control voltages	220 V dc	1 A	0.15 A
	110 V dc	3 A	0.25 A
	48 V dc	5 A	1 A

**Table 3: Communication and power supply**

Data communication	Transmission mode	Fibre-optic serial bus		
	Data code	ASCII		
	Selectable data transfer rates	300, 1200, 2400, 4800 or 9600 Bd		
	Fibre-optic bus connection module, powered from the host relay	for plastic fibre cables	SPA-ZC 21BB	
		for glass fibre cables	SPA-ZC 21MM	
	Fibre-optic bus connection module with a built-in power supply unit	for plastic fibre cables	SPA-ZC 17BB	
for glass fibre cables		SPA-ZC 17MM		
Auxiliary supply modules	Power supply and I/O modules and voltage ranges	SPTU 240S1	80...265 V ac/dc	
		SPTU 48S1	18...80 V dc	
	Power consumption	under quiescent conditions	~4 W	
		under operating conditions	~6 W	

**Table 4: Relay module SPCJ 3C48**

Low-set overcurrent stage I>	Start current I>			0.5...2.5 × I <sub>n</sub>
	Selectable modes of operation	Definite time characteristic	Operate time t>	0.05...100 s
		Inverse definite minimum time (IDMT) characteristic	Curve sets acc. to IEC 255-4	Normal inverse Very inverse Extremely inverse Long-time inverse
			Time multiplier k	0.05...1.00
High-set stage I>>	Start current I>>			0.5...17.5 × I <sub>n</sub> or ∞, infinite
	Operate time t>>			50 ms, 150 ms, 300 ms, 500 ms or ∞, infinite = out of operation
Earth-fault stage I <sub>0</sub> >	Start current I <sub>0</sub> >			0.1...0.8 × I <sub>n</sub>
	Selectable modes of operation	Definite time characteristic	Operate time t <sub>0</sub> >	0.05...100 s
		Inverse definite minimum time (IDMT) characteristic	Curve sets acc. to IEC 255-4	Normal inverse Very inverse Extremely inverse Long-time inverse
			Time multiplier k <sub>0</sub>	0.05...1.00

**Table 5: Tests and standards**

Test voltages	Dielectric test voltage (IEC 60255-5)	2.0 kV, 50 Hz, 1 min
	Impulse test voltage (IEC 60255-5)	5 kV, 1.2/50 μs, 0.5 J
	Insulation resistance (IEC 60255-5)	>100 MΩ, 500 V dc
Interference tests	High-frequency (1 MHz) disturbance test (IEC 60255-22-1), common mode	2.5 kV
	High-frequency (1 MHz) disturbance test (IEC 255-22-1), differential mode	1.0 kV
	Fast transients (IEC 60255-22-4, class III and IEC 60801-4, level 4), power supply inputs	4 kV, 5/50 ns
	Fast transients (IEC 60255-22-4, class III and IEC 60801-4, level 4), other inputs	2 kV, 5/50 ns
	Electrostatic discharge (IEC 60255-22-2 and IEC 60801-2, class III), air discharge	8 kV
	Electrostatic discharge (IEC 60255-22-2 and IEC 60801-2, class III), contact discharge	6 kV
Environmental conditions	Service temperature range	-10...+55°C
	Transport and storage temperature range (IEC 60068-2-8)	-40...+70°C
	Damp heat test (IEC 60068-2-3)	<95%, +40°C, 96 h
	Relative humidity (IEC60068-2-30)	93...95%, +55°C, 6 cycles
	Degree of protection by enclosure when panel mounted	IP 54
	Weight	3 kg

Block diagram

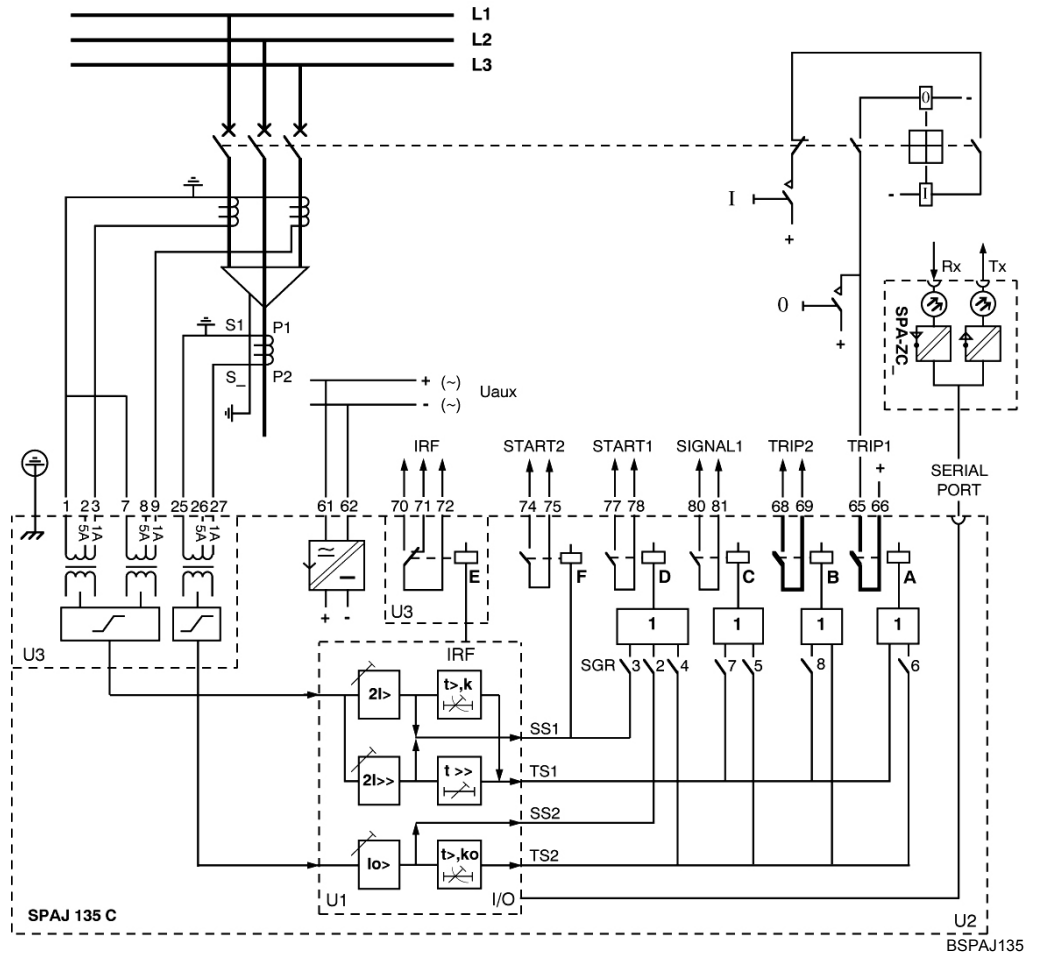

Fig. 1 Block diagram and sample connection diagram

Mounting and dimensions

Flush mounting

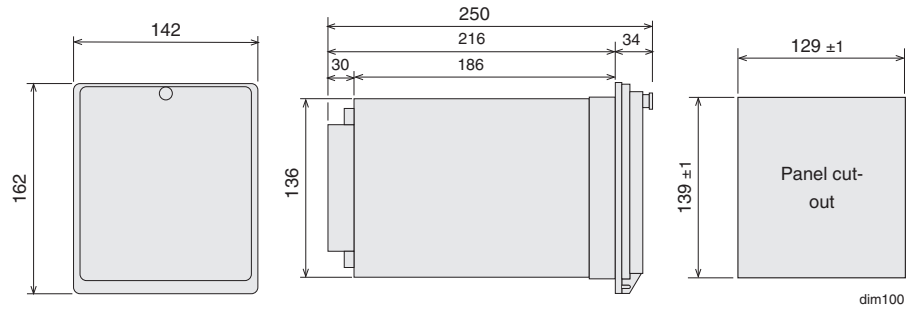

Fig. 2 Flush-mounting relay case (dimensions in mm)

Semi-flush mounting

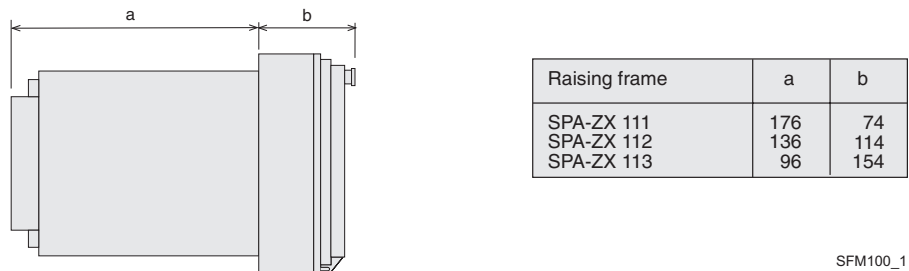

Fig. 3 Semi-flush mounting relay case (dimensions in mm)

Mounting in 19 inch cabinets and frames

An ancillary mounting plate, height 4U (~177 mm), is recommended to be used when the protection relays are to be mounted in 19 inch frames or cabinets. The ancillary mounting plate type SPA-ZX 104 accommodates three relays, type SPA-ZX 105 two relays and type SPA-ZX 106 one relay.

Projecting mounting

When projecting mounting is preferred, a relay case type SPA-ZX 110 is used. The relay case for projecting mounting is provided with front connectors.

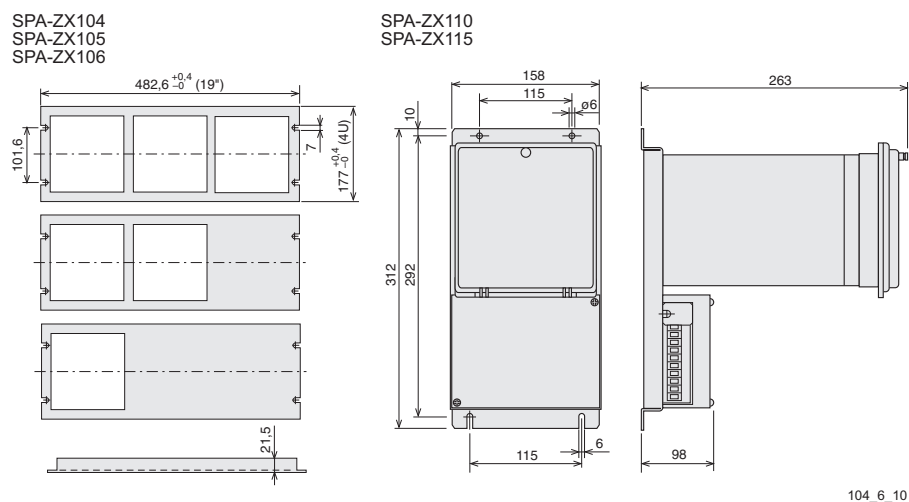

Fig. 4 Mounting cabinets and frames as well as projecting mounting (dimensions in mm)



## Ordering

### When ordering, please specify:

Ordering information	Ordering example
1. Type designation and quantity	SPAJ 135 C, 5 pieces
2. Order number	RS 611 030-AA
3. Rated values	$I_n=5$ A, $f_n=50$ Hz
4. Auxiliary voltage	$U_{aux} = 110$ V dc
5. Accessories	-
6. Special requirements	-

### Order numbers

Combined overcurrent and earth-fault relay SPAJ 135 C without test adapter	RS 611 030-AA, CA, DA, FA
Combined overcurrent and earth-fault relay SPAJ 135 C including test adapter RXP 18	RS 611 230-AA, CA, DA, FA
The last two letters of the order number indicate the rated frequency $f_n$ and the auxiliary voltage $U_{aux}$ of the relay as follows:	AA equals $f_n = 50$ Hz and $U_{aux} = 80...265$ V ac/dc
	CA equals $f_n = 50$ Hz and $U_{aux} = 18...80$ V dc
	DA equals $f_n = 60$ Hz and $U_{aux} = 80...265$ V ac/dc
	FA equals $f_n = 60$ Hz and $U_{aux} = 18...80$ V dc

## References

### Additional information

Manual "Combined overcurrent and earth-fault relay SPAJ 135 C"	1MRS 750811-MUM EN
---	--------------------







**ABB Oy**  
Distribution Automation  
P.O. Box 699  
FI-65101 Vaasa, FINLAND  
Tel +358 10 22 11  
Fax +358 10 224 1094  
[www.abb.com/substationautomation](http://www.abb.com/substationautomation)