

**NOTES:**

- WARNING**  
Using a non-factory RS485 data cable between UCI2 and first unit may result in damage and may void system warranty.
- All installations in hazardous locations must comply with requirements of Certification Drawing 2017275-CD.
- For simplicity, this drawing differs slightly from the wiring interconnect in that power goes to P1-1 for Switched and Continuous. (See Note 4 below)

Jumper 1 to 2 on J10 to terminate last unit on bus.

Jumper 2 to 3 on J10 for first and intermediate units.  
or  
If the first unit is the only unit, jumper 1 to 2 to terminate.

Totalflow RS485 Cable  
P/N 2011648-001  
Between Each Unit

RS-485 Communications Module  
In Comm 1 Of Each Unit.  
Totalflow P/N 2015193-002/003

**Hint:**  
In RS-485 Mode, terminals 6 & 7 (BUS-) and 8 & 9 (BUS+) are common to each other. Therefore, for BUS-, you can go in terminal 6 and out 7 or vice-versa. For BUS+, you can go in terminal 8 and out 9 or vice-versa.

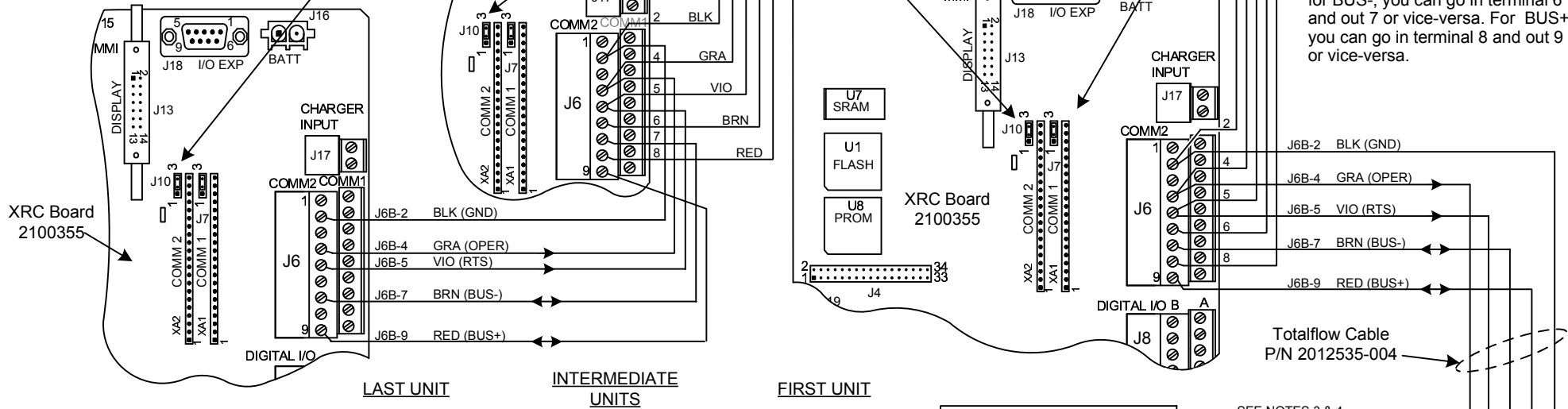

- For Switched power or to enable Power Scheduler for UC12, remove the jumper between 1 & 9 on P1 of UCI2.
- Maximum length of RS485 bus is 4000 Ft. @9600 baud using Totalflow cable P/N 2011648-001 or equivalent.
- Units must be daisy-chained; No Star Configurations.
- Cable Shielding – Cable segments between units should have their shields terminated on one end only. The RS-485 Cable (P/N 2011648-001) has two shields, each with its own drain wire. When connecting multiple units together, connect the two drain wires on the first unit to one of the two ground screws on the bottom left-hand side of the enclosure. Cut the cable and terminate the wiring on the second unit but do not connect the drain wires. On the next segment between the second and third units, connect the two drain wires to the second unit but not to the third unit. Repeat this process until all units are wired.

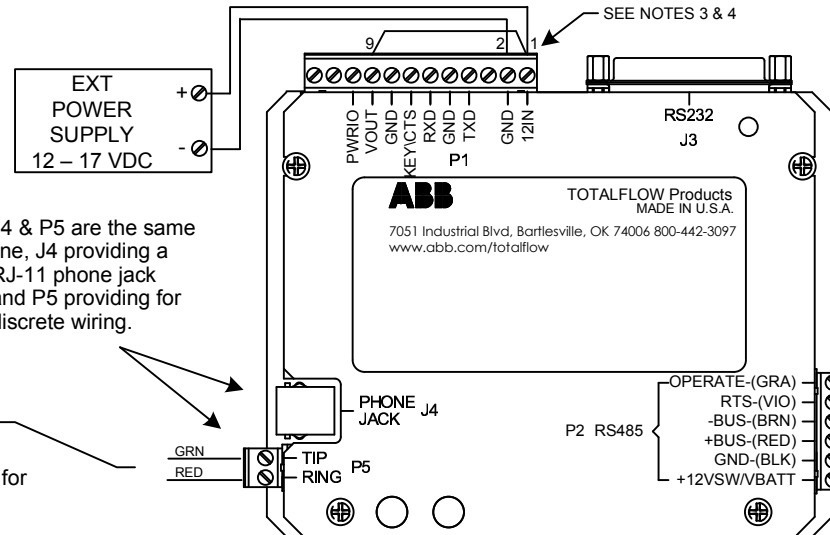

J4 & P5 are the same line, J4 providing a RJ-11 phone jack and P5 providing for discrete wiring.

To phone company if using phone line.

See phone company for recommendations on surge equipment.

REF: 2100656-WI

<b>ABB</b> TOTALFLOW Products	ACTION	DOC TYPE	TITLE	DWG NO.	REV	SHEET
	L17527	UD	XRC 6490/6790/6890 COMM 2 (2100355 BD) TO UC12 W/ SWITCHED EXT PWR (RS-485)	2102223	AA	1 OF 1