



Skipping constraints

CRP Azipod® propulsion creates new business opportunities for Shin Nihonkai ferries of Japan

Lars Anderson, Thomas Hackman

Shin Nihonkai Ferry, the leading ferry operator in Japan, took delivery of two innovative new-builds in 2004. The new RoPax (roll on – roll off passenger) ferries were the first vessels in the world to be installed with ABB's Contra-Rotating Azipod® propulsion. In their first months of operation, the ferries documented a remarkably improved fuel efficiency and transportation economics.

Shin Nihonkai Ferry, SNF Factbox 1, was the first company to open a ferry route in the Sea of Japan in 1970. It was the first to operate large high-speed ferries. In 1995, it had the two ferries, *Suzuran* and *Suisen*, built with maximum speeds of 31 knots. Another example of SNF's innovation was when it selected contra-rotating propulsion (CRP) with electric "pod" propulsion [1] for their two large high-speed ferry new-builds.

The largest and fastest ferries in Japan

The two newest additions to the SNF fleet, *Hamanasu* and *Akashia*, were delivered by Mitsubishi Heavy Industries (MHI), Nagasaki, in 2004.

With an overall length 224.5 meters, and with a service speed of 30.5 knots, these two RoPax ferries are the largest and fastest in Japan **Factbox 2**. They are also the first vessels in the world to take advantage of ABB's contra-rotating Azipod® propulsion system.

Major benefits from CRP pod propulsion

Shin Nihonkai Ferry operates an extensive network of ferry routes between the islands of Honshu and Hokkaido in northern Japan. The main reason for choosing CRP Azipod® propulsion was the increasing cost of bunker fuel. But a number of additional benefits were also gained.

At 573 nautical miles, the Maizuru-Otaru route is the longest in the network. Because of its length, the route had always required three ferries to provide a daily service. These three ferries, operating at 20 knots, covered the distance in 30 hours and were able to keep consistent arrival and departure times in both ports.

In order to provide a daily service with only two ferries, the vessels needed to be larger and able to maintain a cruising speed of 30.5 knots. Shin Nihonkai Ferry had been investigating how this might be achieved, but realized that the cost, in terms of fuel consumption, at these speeds would have been prohibitive.

For a two-ship solution to be viable, a remarkable (yet realistic) reduction in fuel consumption would have to be demonstrated to SNF.

When presented with the CRP Azipod propulsion concept, which promised high fuel oil cost savings, Shin Nihonkai Ferry became interested. After intensive research, MHI chose a single-skeg hull solution with

CRP Azipod propulsion, an azimuthing 17.6 MW Azipod unit installed in a contra-rotating mode, aft of the main propeller **1**.

There is always a risk involved when building a prototype. But, as CRP pod propulsion was the only solution able to achieve a 24-hour schedule and a daily ferry service, the decision to go ahead with the CRP Azipod propulsion was taken. In doing so, SNF and MHI broke the decades-long deadlock

in the marine industry's attempt to seize the full benefits of contra-rotating propulsion **Factbox 3**.

Deliveries from ABB Marine included a 17.6 MW Azipod unit for each of the two ferries, working in tandem with a reduction-gear-driven CP (controllable pitch) pod propeller. ABB also delivered the control systems and the 27-MW, 6.6-kV power generation and distribution systems.

The layout of the propulsion plant features two Wärtsilä 12V46 engines driving a CP propeller through a twin-in/single-out gearbox. Another pair of 12V46 engines drives alternators that feed electrical power to the Azipod unit. The power distribution is 25.2 MW on the CP propeller and 17.6 MW on the Azipod, making 42.8 MW in total. In order to achieve the same vessel speed, a conventional twin-shaft propulsion system would require a total installed power of approximately 47 MW.

Demanding weather conditions

The weather conditions in the Sea of Japan can be divided into two distinct seasons, winter and summer. The winter season lasts from November through March and, during this time, the Sea of Japan is infamously stormy. The air temperature can drop below zero and, even though the sea never actually freezes, ice build-up on ships can be a problem. The winds during the winter storms often reach speeds of more than 30 m/s, with waves in excess of eight meters high.

Shin Nihonkai normally delays or cancels ferry departures when the height of the waves exceeds 5 meters but, because of the length of its routes, weather conditions vary and ferries can be delayed by unexpected storms. Maintaining a high average

Factbox 1 Shin Nihonkai Ferry Co., Ltd.

Trade name	Shin Nihonkai Ferry Co., Ltd.
Personnel	585 (land 231, sea 354)
Head office	Osaka, Japan
Branch office	9 offices in Japan
President	Yasuo Iritani
Main group companies	Kanko Kisen, Hankyu Ferry, Kampu Ferry, Orient Ferry, Japan Cruise Line, Kyowa Shoji

Factbox 2 Ferry specifications

RoPax ferries <i>Hamanasu and Akashia</i>		
Length	224.82	meters
Breadth	26.0	meters
Depth, to 2nd deck	10.0	meters
Draught	7.4	meters
Gross Tonnage	34,131	tons
Deadweight	6,649	tons
Passengers	820	persons
Passenger cabins	144	pcs
Trailer	158	pcs
Private car	65	pcs
Max speed	32.04	knots
Service speed	30.5	knots
Power, installed	50,400	kW
Propulsion power, total	42,800	kW
Azipod® unit	17,600	kW

ABB Scope of Supply per vessel

- 1 × 3,450 kVA, 6.6 kV main generator
- 2 × 14,353 kVA, 6.6 kV main generators
- 3 × neutral point cubicles
- 3 × voltage regulator cubicles
- 1 × 6.6 kV main switchboard
- 2 × propulsion transformers
- 1 × excitation transformer
- 1 × propulsion converter
- 1 × 17.6 MW CRP Azipod® propulsion system
- 2 × thruster motors
- 2 × distribution transformers
- 2 × propulsion transformer pre-magnetizing device
- 2 × UPS
- 1 × CRP propulsion control system

Ingenuity on the move

speed is essential: a reduction in speed of as little as 1.5 knots can cause an hour's delay on this route.

During the summer season, the weather is calmer but the ferry routes are prone to relatively frequent typhoons. These are fairly easy to predict as they tend to be slow moving. Nonetheless, a ferry can be forced to sail through a typhoon to maintain the daily service.

Built to expectations

Mr. Yasuo Iritani, President of Shin Nihonkai Ferry, explains that he decided to go ahead with the project based on the positive result of their studies of the concept.

"The ships are somewhat more expensive than conventional ferries but the operational savings are big enough for

us to recover the initial expense," he explains. Mr Iritani also comments that, with the new ferries, SNF has achieved its main objective of operating a 24-hour service on the Maizuru-Oturu route.

Compared with the existing service, the vehicle turnaround time is reduced by 25 percent.

"Compared with the existing service, the vehicle turnaround time is reduced by 25 percent, which is attractive to cargo distributors. For example, the reduced transportation time makes us an alternative to air cargo for high-grade perishable foodstuffs. This means we are not only improving

our operations, we are also opening up new market opportunities."

Fuel consumption reduced by 20 percent

The target for *Hamanasu* and *Akashia* was to make a 10 percent saving in fuel oil consumption, as compared to conventional twin-screw ferries.

In May 2004, *Hamanasu* was the first ship to embark on the much-anticipated initial sea trials. In the speed tests, with a power split of 55 percent for the forward propeller and 45 percent of the aft, the vessel logged a maximum speed of 32.04 knots – a remarkable achievement.

Even more remarkable was the fuel oil consumption, which set a new benchmark in the industry. The sea

Factbox 3 General benefits of contra-rotating propulsion

There are two main reasons for owners to consider contra-rotating propulsion. One is improved efficiency by being able to absorb rotational losses with the contra-rotating aft propeller. Contra-rotating propulsion also gives the benefit of thrust load distribution over a larger number of propeller blades in a confined space. The added total blade area results in improved cavitation characteristics, by which more power can be fed to a CRP propulsion system with smaller diameter propellers. This is especially important for powerful shallow-draught vessels. Without diameter restrictions, a third benefit is a system with less noise and cavitation. Additionally, by using an azimuthing electric propulsion unit aft, maneuvering characteristics are much improved.

Summary of benefits at Shin Nihonkai

The RoPax ferry *Akashia* and her sistership *Hamanasu* are the first vessels to be fitted with CRP Azipod® propulsion. The new ferries equipped with CRP Azipod® consume 20 percent less fuel than their forerunners – while providing a 15 percent increase in transportation capacity. Further savings are expected to be made through the reduction of operating costs related to maintenance and spare parts of the diesel engines.

The Route:

Daily service between Maizuru – Oturu:
573 NM

The options:

3 ferries – 20.0 knots, 30 hours
2 ferries – 30.5 knots, 20 hours

The challenge: high power needs with high fuel costs

The solution: The four-bladed main (CP) propeller with a diameter of 5.6 meters and an Azipod® propeller with a diameter of 4.8 meters and 5 blades.

From the hydrodynamically-efficient, single-skeg hull to the submerged, podded CRP Azipod® propulsion system, these vessels are designed for smooth sailing. Because power is shared between two propellers, the size of each propeller can be reduced, resulting in less noise and turbulence.

The Azipod® unit also serves as a rudder, smoothing out flow and increasing power. This improves steerability, especially at low speeds, facilitating maneuverability in harbor and reducing docking time.

Shin Nihonkai Ferries – Generic Machinery Arrangement

The total propulsion power is 42.8 MW with 25.2 MW (60 percent) distributed on the forward propeller and 17.6 MW (40 percent) on the Azipod unit.

The *Hamanasu* and *Akashia* ferries experience a remarkable hydrodynamic efficiency gain of 10–15 percent as compared to vessels with conventional twin-shaft arrangements. This ultra-high propulsion efficiency is achieved by combining two separate propulsion systems in a single-shaft configuration; a steerable azimuthing podded propulsion unit installed in a contra-rotating mode, aligned directly downstream of a mechanically driven main propeller but with no physical connection.

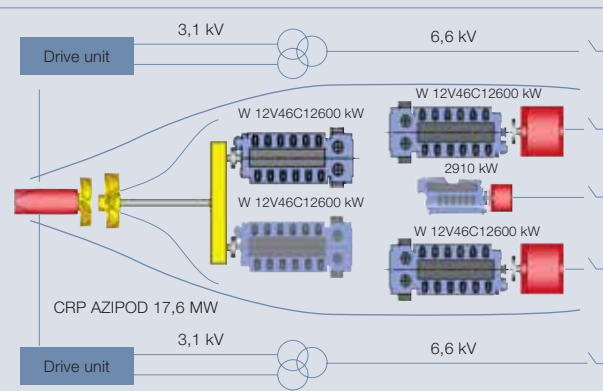

trials confirmed the findings from the extensive test made in MHI's model basin in Nagasaki. After several months of operation on their intended route, the owner has learned that the new vessels, for the same 24-hour service, will save some 20 percent in fuel consumption compared to the two old twin-shaft, diesel-driven ferries, which operated temporarily on the route. The service speed of the twin-shaft ferries was only 29.4 knots and their transportation capacity was 15 percent less than that of the new ships.

Improved maneuverability with Azipod® propulsion

The maneuverability of the ship was also of great interest. When maneuvering at low speeds and in port, the Azipod unit can be used as a rudder and side thruster. At cruising speeds the steering range of the Azipod is restricted, but, despite their size, *Hamanasu* and *Akashia* are able to maneuver at low speed, without tug assistance, in winds up to 18m/s. Under these conditions, smaller, conventional, twin-screw ferries require assistance.

Flexible operation

The propulsion plant also offers great flexibility in terms of power distribution. For example, the ships carry a lot of perishable foodstuffs from Hokkaido, including dairy produce and vegetables. The cargo is transported in refrigerated trailers that require electrical power. However, on their return trip to Hokkaido, refrigeration



is not required and the electrical power can be used, if necessary, for propulsion. Conversely, if weather conditions are favorable, the ship can sail one trip with only three engines, and still remain on schedule.

The new vessels, will save some 20 percent in fuel consumption compared to the two old twin-shaft, ferries.

Operational experience

Mr Kiyoshi Takaoka, Marine Department Manager, says that the company is very pleased with the performance of the new ships. The maneuverability is excellent and the ships are very stable in rough seas.

Mr Takahashi, *Hamanasu's* captain, is also more than satisfied with his ship:

“Under normal weather conditions the course stability is excellent. We do not normally go out if the wave height is above five meters, but sometimes typhoons are unavoidable. Last summer we experienced typhoons and wave heights above eight meters with extreme winds. We reduced speed to 20 knots and, although it was a rough ride, the ship was fully maneuverable. When maneuvering in port, I feel very safe because of the

high thrust available from the Azipod unit; equaling that of two tug boats.”

“When slow-steaming at five knots and below, the steering performance with the Azipod is still remarkable. The acceleration when leaving port is much better compared [to that of] other ships and, at full speed, the stern wave is very small, which indicates good fuel economy.”

Having built these first two vessels, MHI can recommend Azipod CRP propulsion both for ferries and for high-day-rate vessels such as LNG (liquid natural gas) carriers, where redundancy is important.

1 Contra-rotating propellers



Lars Anderson

Wärtsilä Switzerland, Ltd.
Winterthur, Switzerland
lars.anderson@wartsila.com

Thomas Hackman

ABB Oy
Helsinki, Finland
thomas.hackman@fi.abb.com

Reference

[1] ABB Review, 3/2005. “Green shipping”, by Matti Turtiainen