

9AKK107492A9152 | 25.09.2019

## Product manual

# ABB i-bus<sup>®</sup> KNX

## IoT Dashboard Server

### DBS/S 1.1.1.1

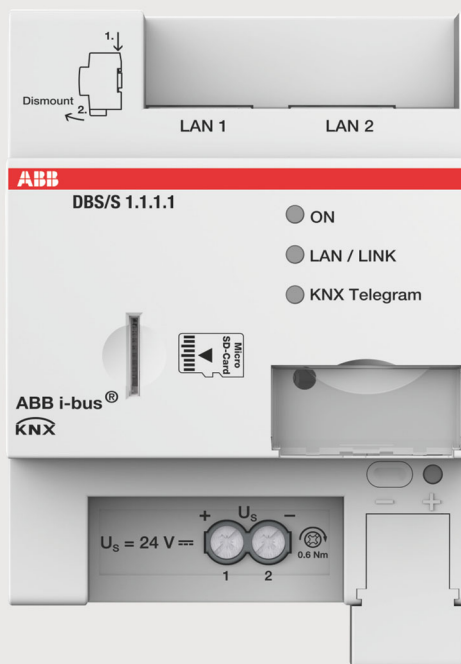

1	Notes on the instruction manual.....	7
2	Safety.....	8
2.1	Intended use .....	9
2.2	Improper use .....	9
2.3	Target group / Qualifications of personnel.....	10
2.4	Safety instructions.....	10
3	Information on protection of the environment .....	11
3.1	Environment .....	11
4	Product description.....	12
4.1	Scope of supply.....	13
4.2	Additional necessary components .....	13
4.3	Device overview.....	14
4.4	Functions.....	15
4.4.1	Function overview .....	15
4.4.2	Description of functions.....	18
4.5	LED colour concept.....	18
5	Technical data .....	19
5.1	Dimensional drawings.....	20
6	Connection, installation / mounting .....	21
6.1	Safety instructions.....	21
6.2	Preparatory steps.....	22
6.3	Mounting.....	23
6.4	Electrical connection .....	24
7	Initial commissioning of the ABB i-bus® KNX IoT Dashboard Server.....	25
8	Commissioning via ABB i-bus® KNX IoT Dashboard Tool.....	27
8.1	Prerequisites .....	27
8.2	Integration into the KNX system (ETS).....	28
8.2.1	Installation of the ABB i-bus® KNX IoT Dashboard ETS App.....	28
8.2.2	Installation of the ABB i-bus® KNX IoT Dashboard Tool.....	29
8.2.3	Integrating the ABB i-bus® KNX IoT Dashboard Server into the ETS .....	29
8.3	Overview of the ABB i-bus® KNX IoT Dashboard Tool .....	30
8.3.1	Starting the ABB i-bus® KNX IoT Dashboard Tool.....	31
8.4	Screen areas of the ABB i-bus® KNX IoT Dashboard Tool.....	33
8.5	Project management.....	35
8.5.1	Creating a project.....	35
8.5.2	Open a project.....	37
8.5.3	Save project .....	37
8.5.4	Project backup .....	38
8.5.5	Restore project.....	39
8.5.6	Close project .....	39
8.5.7	Delete project.....	39

8.5.8	Synchronise project.....	40
8.5.9	Security settings of the ABB i-bus® KNX IoT Dashboard Server .....	42
8.5.10	Uploading a project .....	43
8.5.11	Project Settings .....	46
8.5.12	Symbols library.....	61
8.5.13	Software information .....	63
8.5.14	Other Project settings.....	65
8.6	User rights.....	67
8.6.1	Rights of user groups .....	70
8.6.2	Rights of users .....	71
8.7	Creation of the navigation structure.....	73
8.7.1	Architectural and template mode.....	74
8.7.2	Filter functions.....	75
8.7.3	Project templates .....	76
8.7.4	Creating operating pages for buildings.....	79
8.7.5	Creating operating pages for floors .....	81
8.7.6	Creating operating pages for staircases.....	82
8.7.7	Creating operating pages for corridors .....	83
8.7.8	Creating operating pages for rooms .....	84
8.7.9	Creating operating pages for distribution boards.....	85
8.7.10	Creating custom operating pages.....	86
8.7.11	Editing the navigation structure .....	87
8.7.12	Editing operating pages.....	87
8.8	Configuration of the operating pages.....	89
9	Controls and Parameters.....	90
9.1	General parameters .....	91
9.1.1	Parameters.....	91
9.2	Control "Local scene".....	96
9.2.1	Parameters.....	96
9.2.2	Data points .....	98
9.3	Control "Sequence".....	99
9.3.1	Parameters.....	99
9.3.2	Data points .....	102
9.4	Control "Dimmer preset values".....	103
9.4.1	Parameters.....	103
9.4.2	Data points .....	107
9.5	Control element: "Dimmer slider".....	108
9.5.1	Parameters.....	108
9.5.2	Data points .....	112
9.6	Control "Stepwise dimmer" .....	113
9.6.1	Parameters.....	113
9.6.2	Data points .....	121
9.7	Control "Fan speed preset values" .....	122
9.7.1	Parameters.....	122
9.7.2	Data points .....	129
9.8	Control "Fan speed slider" .....	130
9.8.1	Parameters.....	130
9.8.2	Data points .....	136

9.9	Control "Gauge" .....	137
9.9.1	Parameters.....	137
9.9.2	Data points.....	143
9.10	Control "Remote Scene" .....	144
9.10.1	Parameters.....	144
9.10.2	Data points.....	146
9.11	Control "Scheduler viewer" .....	147
9.11.1	Parameters.....	147
9.11.2	Data points.....	149
9.12	Control "Blind switch" .....	150
9.12.1	Parameters.....	150
9.12.2	Data points.....	163
9.13	Control "Blind slider" .....	164
9.13.1	Parameters.....	164
9.13.2	Data points.....	168
9.14	Control "Switch" .....	170
9.14.1	Parameters.....	170
9.14.2	Data points.....	176
9.15	Control "Trend viewer" .....	177
9.15.1	Parameters.....	177
9.16	Control "Value for slider" .....	179
9.16.1	Parameters.....	179
9.16.2	Data points.....	185
9.17	Control "Weather" .....	186
9.17.1	Parameters.....	186
9.17.2	Data points.....	193
9.18	Control "DALI light" .....	196
9.18.1	Parameters.....	196
9.18.2	Data points.....	204
9.19	Control "DALI emergency light" .....	206
9.19.1	Parameters.....	206
9.19.2	Data points.....	211
9.20	Control "RTC" .....	212
9.20.1	Parameters.....	212
9.20.2	Data points.....	220
9.21	Control "RGBW" .....	223
9.21.1	Parameters.....	223
9.21.2	Data points.....	226
9.22	Control "Energy display" .....	229
9.22.1	Parameters.....	229
9.23	Control "Physical meter" .....	231
9.23.1	Parameters.....	231
9.23.2	Data points.....	232
9.24	Control "Virtual meter".....	233
9.24.1	Parameters.....	233
9.24.2	Data points.....	234
9.25	Control "Page links" .....	235
9.25.1	Parameters.....	235

9.25.2	Data points .....	240
9.26	Control "Image" .....	241
9.26.1	Parameters .....	241
9.27	Editing control elements .....	243
9.27.1	Add control .....	243
9.27.2	Copy and position control .....	243
9.27.3	Delete control .....	244
9.28	Configuration of applications and application pages .....	245
9.28.1	"Scheduler" application .....	245
9.28.2	Parameters .....	249
9.28.3	Application "Alarms" .....	252
9.28.4	Application "Local scene" .....	258
9.28.5	Application "Sequence" .....	261
9.28.6	Application "Trends" .....	263
9.29	Editing of data points .....	269
9.30	Editing group addresses .....	270
9.30.1	Main groups .....	271
9.30.2	Group addresses .....	273
9.31	General assignment .....	275
9.31.1	Converter .....	276
9.31.2	Assignment of an individual control .....	277
9.31.3	Assignment of all functions of a building architectural element .....	280
9.31.4	Project assignment .....	283
9.32	Importing the configuration into the ABB i-bus® KNX IoT Dashboard Server .....	285
9.33	RESET (Resetting the device) .....	286
10	Operation via ABB i-bus® KNX IoT Dashboard .....	287
10.1	General control and display functions .....	287
10.2	Controls .....	292
10.2.1	Basic structures of controls .....	292
10.2.2	Additional basic principles .....	294
10.2.3	Variable controls .....	296
10.3	Special functions .....	303
10.3.1	Edit Mode .....	303
10.4	Control actions of additional applications .....	310
10.4.1	Alarm messages .....	310
10.4.2	Notification Center .....	313
10.4.3	Schedulers .....	316
10.4.4	Trend viewer .....	327
10.4.5	Energy display .....	330
10.5	App applications .....	333
10.5.1	DALI Manager (App application) .....	333
10.6	System settings .....	339
10.6.1	User account settings .....	339
10.6.2	IoT Dashboard Server Settings .....	340
10.6.3	Data and activity logs .....	341
10.6.4	Development .....	342
10.6.5	Update und backup .....	343
10.6.6	Device information .....	344

## Table of contents

11	Update .....	345
11.1	Firmware update .....	345
12	Legal information .....	347
12.1	End User Licence Agreement.....	347
12.1.1	License text ABB i-bus® KNX IoT Dashboard Tool.....	347
13	Maintenance .....	365
14	Notes.....	366
15	Index .....	367

# 1 Notes on the instruction manual

Please read through this manual carefully and observe the information it contains. This will assist you in preventing injuries and damage to property, and ensure both reliable operation and a long service life for the device.

Please keep this manual in a safe place.

If you pass the device on, also pass on this manual along with it.

ABB accepts no liability for any failure to observe the instructions in this manual.

If you require additional information or have questions about the device, please contact ABB or visit our Internet site at:

[www.BUSCH-JAEGER.com](http://www.BUSCH-JAEGER.com)

## 2 Safety

The device has been constructed according to the latest valid regulations governing technology and is operationally reliable. It has been tested and left the factory in a technically safe and reliable state.

However, residual hazards remain. Read and adhere to the safety instructions to prevent hazards of this kind.

ABB accepts no liability for any failure to observe the safety instructions.

The following Instructions point to particular hazards involved in the use of the device or provide practical instructions:



### **Danger**

Risk of death / serious damage to health

- The respective warning symbol in connection with the signal word "Danger" indicates an imminently threatening danger which leads to death or serious (irreversible) injuries.



### **Warning**

Serious damage to health

- The respective warning symbol in connection with the signal word "Warning" indicates a threatening danger which can lead to death or serious (irreversible) injuries.



### **Caution**

Damage to health

- The respective warning symbol in connection with the signal word "Caution" indicates a danger which can lead to minor (reversible) injuries.



### **Attention**

Damage to property

- This symbol in connection with the signal word "Attention" indicates a situation which could cause damage to the product itself or to objects in its surroundings.



### **NOTE**

This symbol in connection with the word "Note" indicates useful tips and recommendations for the efficient handling of the product.



This symbol alerts to electric voltage.



## 2.1 Intended use

The IoT Dashboard Server is a modular DIN-Rail component (MDRC) in Pro *M*-Design. The device is intended for mounting in installation distributors on 35 mm mounting rails. The physical KNX address can be assigned via the Engineering Tool Software (ETS). The software IoT Dashboard Tool for the configuration of the IoT Dashboard Server is available for downloading free of charge ([www.busch-jaeger-catalogue.com](http://www.busch-jaeger-catalogue.com)).

For operation, the device requires a direct current supply  $U_s$  (9 - 36 V DC), which is supplied via an external SELV power adapter. The device is ready for use after the supply voltage is connected. The connection to the KNX bus line is optional. .

## 2.2 Improper use

Each use not listed in Chapter 2.1 “Intended use“ on page 9 is deemed improper use and can lead to personal injury and damage to property.

ABB is not liable for damages caused by use deemed contrary to the intended use of the device. The associated risk is borne exclusively by the user/operator.

The device is not intended for the following:

- Unauthorized structural changes
- Repairs
- Outdoor use
- The use in bathroom areas

### 2.3 Target group / Qualifications of personnel

Installation, commissioning and maintenance of the device must only be carried out by trained and properly qualified electrical installers.

The electrical installer must have read and understood the manual and follow the instructions provided.

The electrical installer must adhere to the valid national regulations in his/her country governing the installation, functional test, repair and maintenance of electrical products.

The electrical installer must be familiar with and correctly apply the "five safety rules" (DIN VDE 0105, EN 50110):

1. Disconnect
2. Secure against being re-connected
3. Ensure there is no voltage
4. Connect to earth and short-circuit
5. Cover or barricade adjacent live parts

### 2.4 Safety instructions



#### **Danger - Electric voltage!**

Electric voltage! Risk of death and fire due to electric voltage of 100 ... 240 V. Dangerous currents flow through the body when coming into direct or indirect contact with live components. This can result in electric shock, burns or even death.

- Work on the 100 ... 240 V supply system may only be performed by authorised and qualified electricians.
- Disconnect the mains power supply before installation / disassembly.
- Never use the device with damaged connecting cables.
- Do not open covers firmly bolted to the housing of the device.
- Use the device only in a technically faultless state.
- Do not make changes to or perform repairs on the device, on its components or its accessories.
- Keep the device away from water and wet surroundings.



#### **Caution! - Risk of damaging the device due to external factors!**

Moisture and contamination can damage the device.

- Protect the device against humidity, dirt and damage during transport, storage and operation.

## 3 Information on protection of the environment

### 3.1 Environment



#### **Consider the protection of the environment!**

Used electric and electronic devices must not be disposed of with domestic waste.

- The device contains valuable raw materials which can be recycled. Therefore, dispose of the device at the appropriate collecting depot.

All packaging materials and devices bear the markings and test seals for proper disposal. Always dispose of the packaging material and electric devices and their components via the authorized collecting depots and disposal companies.

The products meet the legal requirements, in particular the laws governing electronic and electrical devices and the REACH ordinance.

(EU Directive 2012/19/EU WEEE and 2011/65/EU RoHS)

(EU REACH ordinance and law for the implementation of the ordinance (EC) No.1907/2006).

## 4 Product description



Fig. 1: Product overview

The IoT Dashboard Server is a modular DIN-Rail component (MDRC) in Pro M-Design. The device is intended for mounting in installation distributors on 35 mm mounting rails. It serves as a control and communication device and for the representation and operation of standard KNX functions (see chapter 4.4.1 “Function overview” on page 15).

The device requires a supply voltage  $U_S$  (9 - 36 V DC), which is supplied via an external SELV power adapter. The device is ready for use after the direct current supply is connected. The connection to the KNX bus line is optional.

The physical KNX address can be assigned via the Engineering Tool Software (ETS). The software ABB i-bus<sup>®</sup> KNX IoT Dashboard Tool (in the following called IoT Dashboard Tool) for the configuration of the IoT Dashboard Server is available for downloading free of charge ([www.busch-jaeger-catalogue.com](http://www.busch-jaeger-catalogue.com)). The information from the building can be displayed via the ABB i-bus<sup>®</sup> KNX IoT Dashboard software (in the following called IoT Dashboard). The parameters are set via the IoT Dashboard Tool.

Additional product features:

- Logically arranged dashboard
- Simple control of KNX functions in the building
- Scenes and schedulers can be edited and/or adjusted by the end customer
- Overview of messages in the notification center
- Display of alarm messages

### 4.1 Scope of supply

The IoT Dashboard Server is included in delivery.

The 8 mm bus connection terminal for the KNX bus necessary for the optional connection with the ABB i-bus® KNX is included.

### 4.2 Additional necessary components

- Power adapter for the 9 - 36 V DC (SELV) power supply U<sub>s</sub>
- LAN cable
- Micro SD card
- Software IoT Dashboard
- Software IoT Dashboard Tool

### 4.3 Device overview

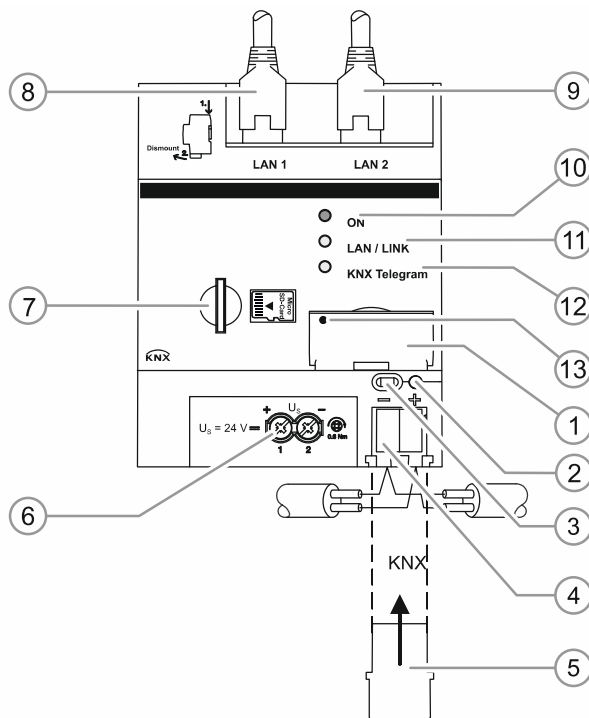

Fig. 2: Overview of devices

- [1] Label holder
- [2] Programming LED (red)
- [3] Programming button
- [4] Bus connection terminal
- [5] Cover cap
- [6] Supply voltage  $U_s$
- [7] Micro SD card slot
- [8] LAN 1 connection (10/100/1000 Base-T)
- [9] LAN 2 connection (10/100 Base-T)
- [10] LED ON (green)
- [11] LED LAN / Link (yellow)
- [12] LED KNX telegram (yellow)
- [13] Reset button (behind label holder)

## 4.4 Functions

### 4.4.1 Function overview

The following tables provide an overview of the different controls and applications of the device.

Controls	
<b>Buttons</b>	<ul style="list-style-type: none"> <li>▪ Switches</li> <li>▪ Value for slider</li> </ul>
<b>Dimmer</b>	<ul style="list-style-type: none"> <li>▪ Dimmer slider</li> <li>▪ Dimmer preset values</li> <li>▪ Dimmer stepwise</li> </ul>
<b>Blind</b>	<ul style="list-style-type: none"> <li>▪ Blind slider</li> <li>▪ Blind button</li> </ul>
<b>Scenes</b>	<ul style="list-style-type: none"> <li>▪ Local scene</li> <li>▪ Remote scene</li> <li>▪ Sequence</li> </ul>
<b>Fan</b>	<ul style="list-style-type: none"> <li>▪ Fan speed slider</li> <li>▪ Fan slider</li> <li>▪ Fan speed slider preset values</li> </ul>
<b>Image</b>	<ul style="list-style-type: none"> <li>▪ Image</li> </ul>
<b>DALI light</b>	<ul style="list-style-type: none"> <li>▪ DALI lights</li> <li>▪ DALI emergency light</li> </ul>
<b>Room temperature controller</b>	<ul style="list-style-type: none"> <li>▪ RTC</li> </ul>
<b>List view</b>	<ul style="list-style-type: none"> <li>▪ List viewer</li> </ul>
<b>RGBW operation</b>	<ul style="list-style-type: none"> <li>▪ RGBW</li> </ul>
<b>Page link</b>	<ul style="list-style-type: none"> <li>▪ Page link</li> </ul>
<b>Value display elements / Value sending elements</b>	<ul style="list-style-type: none"> <li>▪ Display</li> <li>▪ Value for slider</li> <li>▪ Measuring device</li> <li>▪ Scheduler viewer</li> <li>▪ Trend viewer</li> <li>▪ Energy viewer</li> <li>▪ Weather</li> <li>▪ Card viewer</li> </ul>
<b>Energy monitoring</b>	<ul style="list-style-type: none"> <li>▪ Energy viewer</li> </ul>
<b>Scheduler viewer</b>	<ul style="list-style-type: none"> <li>▪ Scheduler viewer</li> </ul>
<b>Display viewer</b>	<ul style="list-style-type: none"> <li>▪ Display</li> </ul>
<b>Card viewer</b>	<ul style="list-style-type: none"> <li>▪ Card viewer</li> </ul>
<b>Meter</b>	<ul style="list-style-type: none"> <li>▪ Physical meter</li> <li>▪ Virtual meter</li> </ul>

Table 1: Overview of controls



#### Notice

For a more detailed description of the controls, see chapter 10.2.3 “Variable controls” on page 296.

<b>Applications</b>	
<b>Time schedule</b>	Configuration of, e.g. weekday timer, yearly timer
<b>Alarms</b>	Configuration of alarm messages
<b>Trend viewer</b>	Statistical details on system procedures
<b>Scenes</b>	Grouping of individual actions to one action.
<b>Sequence</b>	Grouped actions are started in a specified predetermined order.
<b>Notifications</b>	Display of messages on alarms, system information and updates.

Table 2: Overview of applications

**Notice**

For a more detailed description about the applications, see Chapter 9.28 “Configuration of applications and application pages” on page 245 and Chapter 10.4 “Control actions of additional applications “ on page 310.



Applications are listed in the following which must be acquired additionally at a charge.

<b>Applications</b>	
DALI manager	Activate and configure DALI lamps via the IoT Dashboard App.

Table 3: Overview of applications subject to a charge

#### 4.4.2 Description of functions

Parameter settings on the components of a KNX system can be made via the IoT Dashboard Server and the associated software IoT Dashboard Tool. The system can be operated via computer, tablet or smartphone with the aid of the user interface of the IoT Dashboard .

The IoT Dashboard Server is integrated independent from the manufacturer of the KNX devices used. The device can already be integrated into the existing KNX projects and is suitable for small to medium-sized buildings such as schools, office complexes and hotels.

#### 4.5 LED colour concept

The device is equipped with four LEDs with different functions. The colour concept of the LEDs is listed in the following:

LED	LED colour	Function
LED ON	Green	<ul style="list-style-type: none"> <li>▪ Off when there is no power supply</li> <li>▪ Flashes slowly during the startup of the system (1 Hz)</li> <li>▪ Lights up permanently when the startup of the system was successful</li> <li>▪ Flashes fast during the startup of the device (4 Hz)</li> <li>▪ Flashes during the reset of the device (3 Hz)</li> <li>▪ Flashes during the reset of the IP address (3 Hz)</li> <li>▪ Flashes during resetting to the factory settings (3 Hz)</li> </ul>
LED LAN / LINK	Yellow	<ul style="list-style-type: none"> <li>▪ Off when there is no power supply or the LAN ports are not connected with the IP router/switch</li> <li>▪ Lights up permanently when the device is ready for operation and one of the LAN ports is connected with an IP router/switch</li> <li>▪ Flickers during traffic on the LAN ports</li> <li>▪ On when resetting the device</li> <li>▪ Flashes during the reset of the IP address (3 Hz)</li> <li>▪ Flashes during resetting to the factory settings (10 Hz)</li> </ul>
LED KNX telegram	Yellow	<ul style="list-style-type: none"> <li>▪ Off when there is no power supply or no connection to the KNX/TP bus</li> <li>▪ Lights up permanently when the device is ready for operation and connected with the KNX/TP bus</li> <li>▪ Flickers during traffic on the KNX/TP bus</li> <li>▪ On when resetting the device</li> <li>▪ On when resetting the IP address</li> <li>▪ Flashes during resetting to the factory settings (10 Hz)</li> </ul>
Programming LED	Red	<ul style="list-style-type: none"> <li>▪ Off when the device is not in programming mode</li> <li>▪ On in programming mode</li> </ul>

## 5 Technical data

Designation	Value
<b>Power supply</b>	
	9 - 36 V DC, Standard 24 V DC SELV (-10% / +10%)
Power consumption of device	5 W max.
<b>Inputs / Outputs</b>	
Screw-type terminal with combi-head (PZ 1)	Single-wire: 0.5 - 2.5 mm (2x 0.5 - 1.5 mm <sup>2</sup> ) Fine-wire 0.5 - 2.5 mm <sup>2</sup> (2x 0.5 - 1.5 mm <sup>2</sup> )
Wire end sleeve	Without / with plastic sleeve 1 wire without: 0.5 - 2.5 mm <sup>2</sup> 1 wire with: 0.5 - 1.5 mm <sup>2</sup> 2 wires without: 0.5 - 0.75 mm <sup>2</sup> 2 wires with: 0.5 - 0.75 mm <sup>2</sup>
TWIN wire end sleeve	0.5 - 2.5 mm <sup>2</sup>
Tightening torque	Max. 0.6 Nm
<b>KNX connection</b>	
Power supply (via bus line)	24 VDC
Power consumption, bus	< 10 mA
Bus connection terminal	Screwless supplied (0.6 - 0.8 mm <sup>2</sup> )
Line type	J-Y(St)Y, 2 x 2 x 0.8 mm
Wire stripping	5 - 6 mm
<b>LAN connections</b>	
LAN connection 1	10/100/1.000 BaseT, IEEE 802.3 via RJ45 plug
LAN connection 2	10/100 BaseT, IEEE 802.3 via RJ45 plug
Cable type	Shielded network cable of category: at least CAT 5e S/UTP, F/UTP
<b>Micro SD card reader (up to 2 TB)</b>	microSD, microSDHC, microSDXC (not included in the scope of delivery)
<b>Dimensions</b>	70 x 90 x 64.5 mm (H x W x D)
<b>Temperature range</b>	
During operation (Tu)	-5°C - +45°C
Storage	-40°C - +85°C
Transport	-25°C - +70°C
<b>Protection rating</b>	IP20
<b>Air pressure</b>	Atmosphere up to 2,000 m

Table 4: Technical data

## 5.1 Dimensional drawings

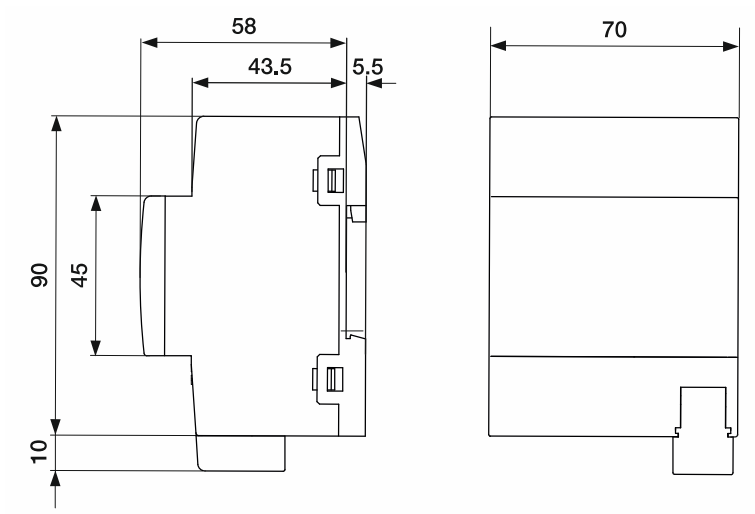

Fig. 3: Dimensions of the device

All dimensions are in millimetres.

Mounting in installation distributors on 35 mm mounting rails.

## 6 Connection, installation / mounting

### 6.1 Safety instructions



#### **Danger - Electric shock due to short-circuit!**

Risk of death due to electrical voltage of 100 to 240 V during short-circuit in the low-voltage line.

- Low-voltage and 100 - 240 V lines must not be installed together in a flush-mounted box!
- Observe the spatial division during installation (> 10 mm) of SELV electric circuits to other electric circuits.
- If the minimum distance is insufficient, use electronic boxes and insulating tubes.
- Observe the correct polarity.
- Observe the relevant standards.



#### **Danger - Electric voltage!**

Install the device only if you have the necessary electrical engineering knowledge and experience.

- Incorrect installation endangers your life and that of the user of the electrical system.
- Incorrect installation can cause serious damage to property, e.g. due to fire.

The minimum necessary expert knowledge and requirements for the installation are as follows:

- Apply the "five safety rules" (DIN VDE 0105, EN 50110):
  1. Disconnect
  2. Secure against being re-connected
  3. Ensure there is no voltage
  4. Connect to earth and short-circuit
  5. Cover or barricade adjacent live parts.
- Use suitable personal protective clothing.
- Use only suitable tools and measuring devices.
- Check the type of supply network (TN system, IT system, TT system) to secure the following power supply conditions (classic connection to ground, protective earthing, necessary additional measures, etc.).



#### **Caution! The device can sustain damage when coming into contact with hard objects!**

The plastic parts of the device are sensitive.

- Pull the attachment off only with your hands.
- Do not lever parts off with screwdrivers or similar hard objects.

## 6.2 Preparatory steps



### **Notice**

The device is a product of the KNX system and meets KNX policies. Detailed expert knowledge by means of KNX training sessions for a better understanding is assumed. And for all additional components of building automation the appropriate know-how must be available if they are to be used in the system.

### 6.3 Mounting

The modular DIN rail component must only be installed on mounting rails according to DIN EN 50022 / DIN 60715 TH 35 (including industrial version).

#### Installation

To install the device, perform the following steps:

- Latch the modular DIN rail component onto the mounting rail.

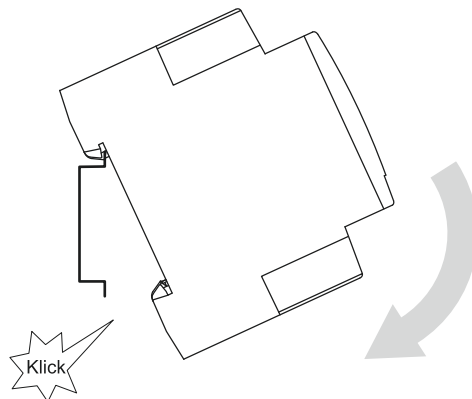

Fig. 4: Installation on mounting rails

#### Dismantling

To dismantle the device, perform the following steps:

- Press the device upwards [1] and then fold it toward the front [2].

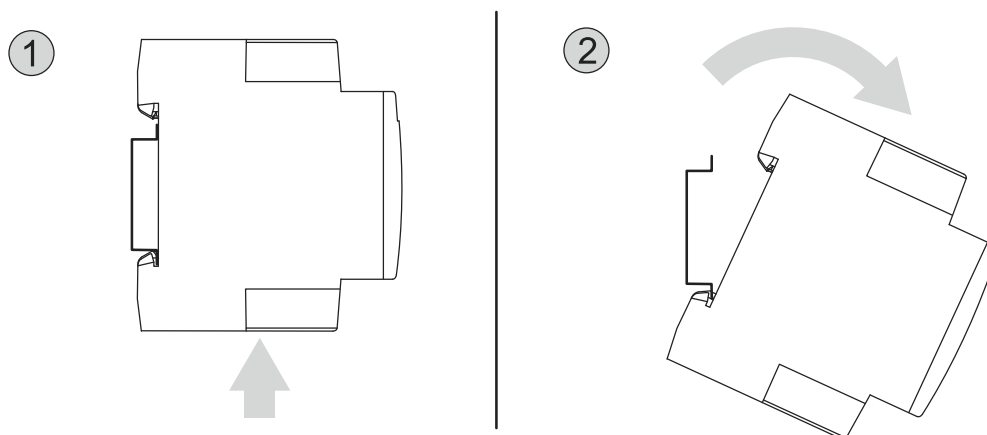

Fig. 5: Removal from the mounting rails

**6.4 Electrical connection**

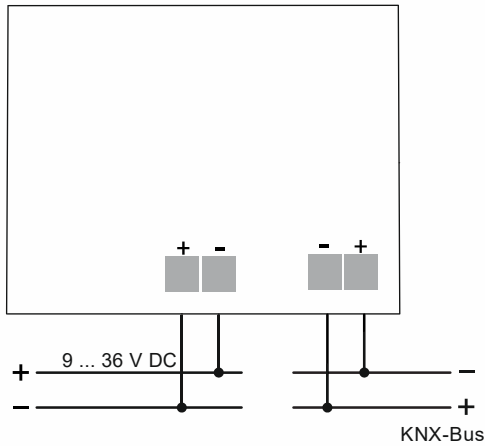

Fig. 6: Electrical connection

Designation	Function
Bus connection terminal	The connection to the KNX bus is made with the enclosed bus connection terminals.
Supply voltage $U_s$	The supply voltage $U_s$ is supplied via an external SELV power adaptor.
LAN 1 connection (10/100/1000 Base-T)	The connection to the IP network is established via a connection with RJ 45 plugs.
LAN 2 connection (10/100 Base-T)	The connection to the IP network is established via a connection with RJ 45 plugs.



**Notice**

The terminal designation is located on the housing.

**Supply voltage  $U_s$**

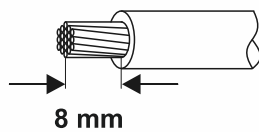

Fig. 7: Skinning length

Skinning length: 8 mm

**Bus connection terminal**

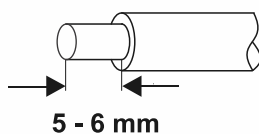

Fig. 8: Skinning length

Skinning length: 5 - 6 mm



## 7 Initial commissioning of the ABB i-bus® KNX IoT Dashboard Server

Initial commissioning follows the successful mounting and installation of the IoT Dashboard Server. The device starts automatically when the power supply is connected.

Prerequisite for the use of the IoT Dashboard Server is a functioning network connection. The connection to the IP network is established via a connection with RJ 45 plugs (shielded network cable cat. at least CAT 5e S/UTP, F/UTP). Use one of the LAN connections on the device.

LAN connection 1	10/100/1.000 BaseT, IEEE 802.3 via RJ45 plug
LAN connection 2	10/100 BaseT, IEEE 802.3 via RJ45 plug



### Notice

In the state of delivery both LAN connections of the IoT Dashboard Server are configured in the DHCP mode.

- To ensure that the assigned IP address can be displayed in the IoT Dashboard Tool, the device must be connected to a DHCP server. Scan in the IoT Dashboard Tool, to ensure that the assigned IP address is displayed.
- Please check your network connection if no device can be found. Both your PC/laptop and the IoT Dashboard Server must be connected in the same IP sub-network. Check the settings of the DHCP server used to see whether it has assigned an IP address to the IoT Dashboard Server. When using a router with an activated DHCP server, please log yourself into the router and check the assigned IP address under "Connected devices". Please contact your system administrator if you have problems in finding the IP address or do not have access rights.

### Access to the Web-Interface of the IoT Dashboard Server un Security warning

After a network connection has been successfully established, you can access the Web-Interface of the IoT Dashboard Server. First enter the assigned IP address of the device with the prefix "https://" in a supported browser (Google Chrome, Mozilla Firefox, Apple Safari), (an example: <https://192.168.2.22>).



### Notice

According to the general security requirements the IoT Dashboard Server is supplied with an activated Web encryption. For this the device uses a self-generated SSL certificate in the basic settings. Most Web browsers classify this self-coded certificate as not trustworthy and display a corresponding warning message. However, the established connection still meets the highest security requirements.

### Background:

Technically and logistically the IoT Dashboard Server can only be delivered with a self-coded certificate that has not been issued by an official master certification authority (Root Certificate Authority). Since the Web browser does not know the trustworthy authority of the certificate used, a corresponding warning is displayed.

In the browser window buttons are displayed similar to "Extended" and "Continue unsafe" with which you can bypass the displayed security warning and continue with the loading of the website. If you want to bypass the security warning permanently, you need to add a security exception on your computer for the device. For this you need to first export the security certificate and then add it to the trustworthy master certification authorities on your computer. The procedure is described in the following by means of an example of Google Chrome.

## Exporting the security certificate

1. Enter the IP address of the IoT Dashboard Server with the prefix "https://" in the search line of your browser.
  - The security warning will be displayed.
2. Click on the lock symbol next to the search line and select option "Certificate".
  - The certificate menu opens.
3. Change to tab "Details" and click on option "Copy into file...".
  - The certificate wizard opens.
4. Click on "Next" and specify the desired format (DER coding binary X.509).
5. Click on "Next" and specify the memory path under which the security certificate is to be saved.
6. Then click on "Next" and confirm the action by clicking on "Finish".
  - After the successful exporting process, the message "The export process was successfully finished" is displayed.

## Installing the security certificate

1. Change to the memory path on which you exported the security certificate and click on the certificate file with right mouse button.
2. Click on option "Install certificate".
3. Specify a memory location ("Current user" or "Local computer") and confirm by clicking on "Next"
4. Under "Certificate memory" select the option "Save all certificates in the following memory" and then click on "Search...".
5. Select the folder "Trustworthy master certificate authorities" as certificate memory and confirm by clicking on OK.
6. Then click on "Next" and confirm the action by clicking on "Finish".
  - After the successful importing process, the message "The import process was successfully finished" is displayed.



### Notice

If you wish to store a new security certificate a later point in time, proceed as described in Chapter 8.5.9 "Security settings of the ABB i-bus® KNX IoT Dashboard Server" on page 42.

## 8 Commissioning via ABB i-bus® KNX IoT Dashboard Tool

The information from the building can be displayed via the IoT Dashboard software. A number of selected parameters can be set via the IoT Dashboard. However, the parameters are mainly set via the IoT Dashboard Tool.



### Notice

The physical KNX address can be assigned via the Engineering Tool Software (ETS).

The commissioning procedure is subdivided as described in the following:

1. Installation
  - The latest Firmware version is located in the electronic catalogue ([www.busch-jaeger-katalog.de](http://www.busch-jaeger-katalog.de)). The Firmware is updated via one of the two LAN connections.
2. Configuration
  - The configuration is carried out via the IoT Dashboard Tool application. The system configuration is created with this software.
3. Operation
  - Operation is carried out via browser application IoT Dashboard. The configuration can first be tested in the IoT Dashboard Tool .

### 8.1 Prerequisites

#### IoT Dashboard Tool

To use the IoT Dashboard Tool you need a terminal device with LAN or WLAN network adapter.

The following operating systems are supported:

- Windows 10

The following ETS versions are supported:

- ETS5

#### IoT Dashboard

To open the Web-based user interface of the IoT Dashboard you require a terminal device (computer, smartphone, tablet) with LAN or WLAN network adaptor and an installed Internet browser.

The following browsers are supported:

- Google Chrome
- Mozilla Firefox
- Apple Safari

## 8.2 Integration into the KNX system (ETS)



### Note

The device meets KNX guidelines and can be used as product of the KNX system. Detailed expert knowledge for understanding by means of KNX training is assumed, especially with regard to the commissioning software ETS.

### 8.2.1 Installation of the ABB i-bus® KNXIoT Dashboard ETS App

For the correct import or export of group addresses a special app, the IoT Dashboard ETS App must be installed for the IoT Dashboard Server.

The installation of the IoT Dashboard ETS App is optional. The app must be installed when an existing building structure from the ETS is to be taken over into the IoT Dashboard Tool.



### Notice

The current application with the corresponding software information is available for download in the electronic catalogue at:

- [www.busch-jaeger-catalogue.com](http://www.busch-jaeger-catalogue.com)

### Installation process

The IoT Dashboard ETS App (etsapp-file, IoT Dashboard ETS App) for the IoT Dashboard Tool is installed via the ETS. The app can be downloaded the My KNX access.

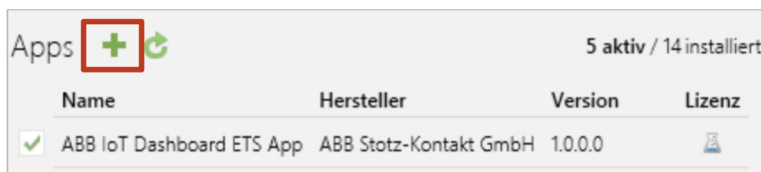

Fig. 9: Installation of the IoT Dashboard ETS App

## 8.2.2 Installation of the ABB i-bus® KNX IoT Dashboard Tool

To create the system configuration, first the IoT Dashboard Tool must be installed. Proceed as described in the following.



### Notice

The IoT Dashboard Tool software is available for downloading without charge at the following link:

- [www.busch-jaeger-catalogue.com](http://www.busch-jaeger-catalogue.com)

### Installation process

The IoT Dashboard Tool is installed via the "IoT Dashboard Tool Setup Wizard".

1. Start the install wizard by double clicking the .exe file.
2. Follow the instructions of the install wizard.

## 8.2.3 Integrating the ABB i-bus® KNX IoT Dashboard Server into the ETS



### Notice

The devices are products of the KNX system and meet KNX policies. Detailed expert knowledge by means of KNX training sessions for a better understanding is assumed.

To start the device a physical address must be assigned first. To assign the physical address the device must be integrated into the Engineering Tool Software (ETS).

## 8.3 Overview of the ABB i-bus® KNX IoT Dashboard Tool

The following section contains basic information about the IoT Dashboard Tool.

The IoT Dashboard Tool is a project planning software with which you can plan and display your building automation. Project planning and the Dashboard can be carried out according to your individual requirements.

Essential tasks during project planning with IoT Dashboard Tool are:

- Takeover of the navigation structure from the ETS, e.g. floors and rooms with associated operating pages.
- Configuration of pages, e.g. arrangement of buttons.
- Configuration of controls, e.g. parameterisation, selection of button symbols.
- Configuration of applications.
- Link with group addresses for the execution of functions (e.g. switching lights on/off).
- Specifying basic settings, e.g. user rights.
- Software update via a microSD card or the Internet.



### Notice

Basic information for operation and the viewers of the IoT Dashboard Tool is available in the context-sensitive online Help of the application. This can be opened via the corresponding Help symbols.

## 8.3.1 Starting the ABB i-bus® KNX IoT Dashboard Tool

After the successful installation (see chapter 8.2.2 “Installation of the ABB i-bus® KNX IoT Dashboard Tool“ on page 29) start the IoT Dashboard Tool as described in the following:

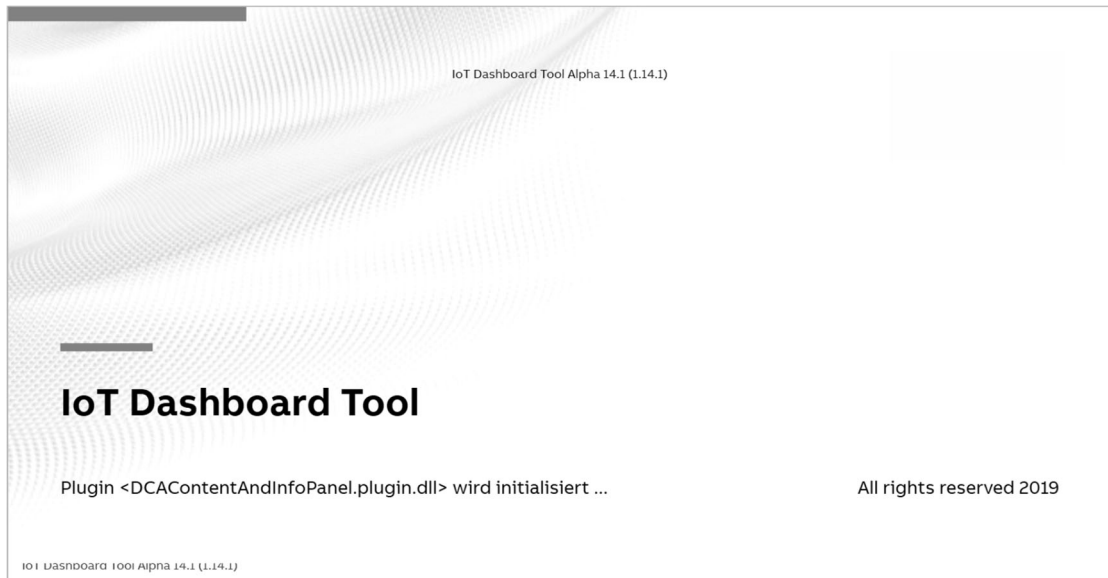
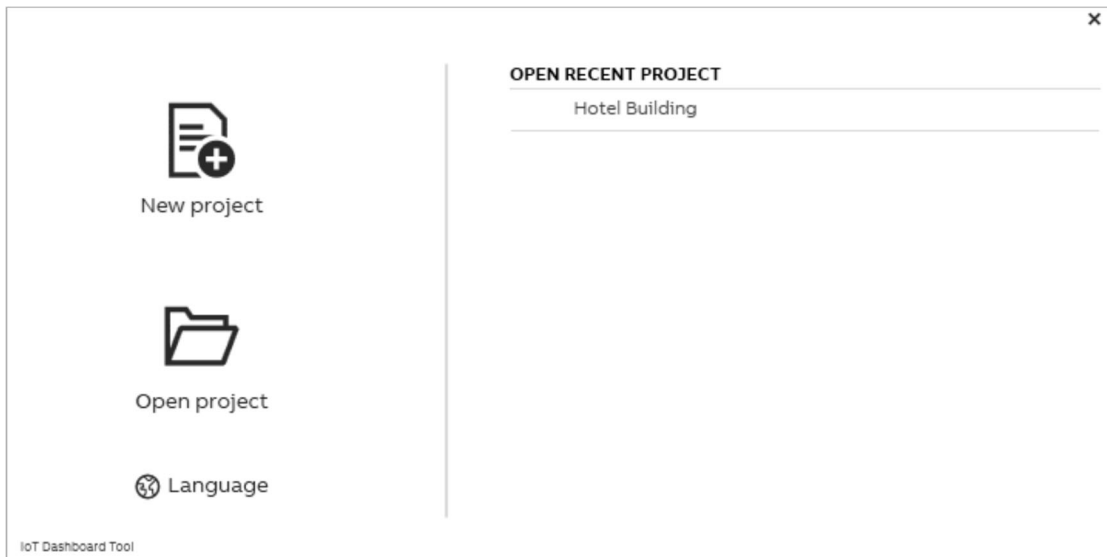

Fig. 10: Start screen of the IoT Dashboard Tool

1. Start the IoT Dashboard Tool.
  - The start screen of the IoT Dashboard Tool opens and the software is initialised.
  - The start menu opens.
2. Click on the "Language" button to start the software in your desired language.



## Notice

During the first start of the IoT Dashboard Tool the software checks whether the language of the operating system is supported by the IoT Dashboard Tool. If yes, then the language of the operating system is fixed as the standard language. If not, then English is fixed as the standard language.

3. Select the desired language in the drop-down menu.
4. Confirm the selection of your choice by clicking on "Change" or "Change and restart".
  - Please note that changes become effective only after a reboot.
5. Select whether you wish to create a new project or open an existing one (see chapter "Creating a project" on page 35 and Chapter 8.5.2 "Open a project" on page 37). As alternative, you can also select a project you recently edited from the list in the right area of the menu.
  - Your project is displayed in the IoT Dashboard Tool according to your selection.



## 8.4 Screen areas of the ABB i-bus® KNX IoT Dashboard Tool

The IoT Dashboard Tool subdivides itself into several areas and tabs in which you are working during planning. In this section the various functions of these areas and tabs are described.

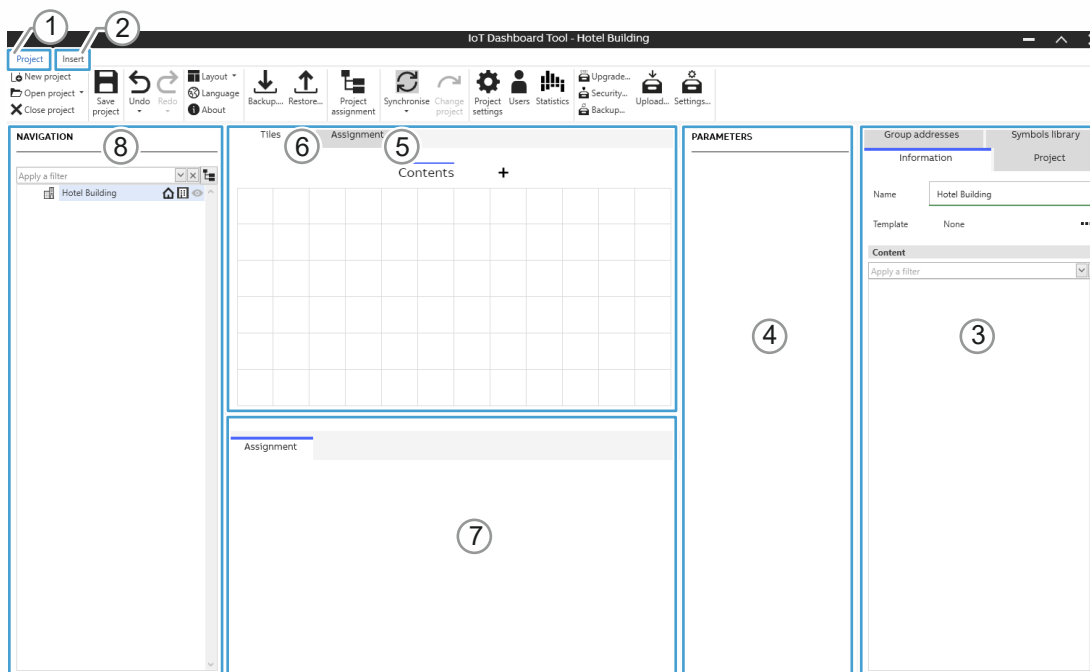

Fig. 11: IoT Dashboard Tool screen areas

Pos.	Description of functions	
[1]	<b>"Project" tab</b> Access to the various project functions, e.g. New project, Open project, Save project, Layout, User, Settings, etc.	
[2]	<b>"Paste" tab</b> Comprises the available controls.	
[3]	This area comprises the different tabs.	
	<b>"Information" tab</b> Comprises the applications, controls, etc. configured for an operating page. Here the selected operating pages from the navigation can be renamed. It is additionally possible to assign a template to the operating pages, and to configure schedulers, for example.	
	<b>"Project" tab</b> Depicts a building structure with floors, rooms and staircases created by the user or imported from the ETS. The view takes place in the architectural or template mode.	
	<b>"Group addresses" tab</b> Configuration of group addresses (specifying of properties, data types, etc.).	
[4]	<b>"Symbols library" tab</b> Comprises available symbols which can be assigned to the controls via drag and drop in the "Parameter" area.	
	<b>"Parameter" area</b> This area comprises the configurable parameters for a control. The parameters can be used to make general and functionally specific settings on the controls. The "Parameter"	<b>"General" tab</b> Configuration of general properties.
		<b>"Representation" tab</b> Configuration of the representation in the control.
		<b>"Behaviour" tab</b> Configuration of the behaviour when executing functions.

	area is subdivided into the following tabs:	<b>"Function" tab</b> Configuration of the behaviour of functions.
[5]	<b>"Assignment" tab</b> Gives a complete overview of the controls used in the project and the available or configured data points.	
[6]	<b>"Tiles" tab</b> Graphically depicts all created operating pages in the form of tiles with all controls used.	
	This area comprises the different tabs. Which tabs are available depends on the control selected.	
	<b>"Assignment" tab</b> Lists the available data points of a selected control. Field bus points can be assigned to the data points.	
[7]	<b>"Alarms" tab</b> Lists all data points of a selected control for which alarm messages can be configured, or have been configured.	
	<b>"Trends" tab</b> Lists all data points of a selected control for which trends can be configured, or have been configured.	
	<b>"Scenes" tab</b> Configuration of scenes.	
	<b>"Values" tab</b> Lists different configured values with additional information.	
[8]	<b>"Navigation" tab</b> Depicts a building structure with floors, rooms and staircases created by the user or imported from the ETS. The view takes place in the architectural or template mode.	

Table 5: IoT Dashboard ToolScreen areas

## 8.5 Project management

The ribbon bar in the "Project" tab can be used to create new projects, open existing projects, store projects and make further project and user settings. In addition, a backup can be created or loaded into the project for restoration.



Fig. 12: "Project" tab

### 8.5.1 Creating a project

A new project can be created either via the start screen of the IoT Dashboard Tool or from a project that is already open.

#### Creating a new project

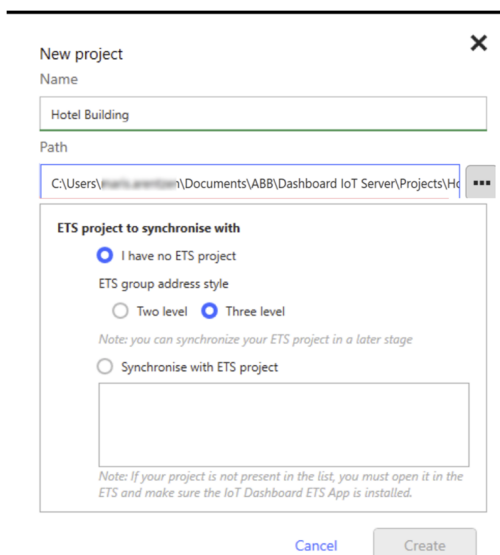

Fig. 13: Creating a new project

1. A new project is created as follows:
  - In the start screen click on the "New project" button.

OR

  - In a project that is already open in the project tab, click on the option "New project".
  - The project window opens.
2. Assign a project name under "Name" and under "Path" specify the memory path under which the project is to be saved.
  - A valid name and memory path is marked in the menu with a green line. When you select a memory path under which a different project has already been stored, the message "The directory contains files" is displayed. In this case select a different memory path.

**Notice**

In the following step you specify whether you wish to synchronise the project with an existing ETS project (see Chapter 8.5.8 “Synchronise project” on page 40).

3. Then select whether you have an existing ETS project whose building configuration you wish to import into the IoT Dashboard Tool.
  - If you do not have an existing ETS project for importing, select the option "I do not have an ETS project" and specify in how many levels your group addresses are to be subdivided (options "Two levels" or "Three levels").
  - If you do not wish to import an existing ETS project into your project, select the option "Synchronise with ETS project" and select the desired project.
4. Finally click on "Create".
  - The software creates the new project.

**Notice**

If you do not wish to import a building configuration from an existing ETS project during your creation of a project, you can do this at any time later (see chapter 8.5.8 “Synchronise project” on page 40).

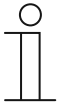
**Notice**

If your project is not displayed in the list under "Synchronise with ETS project", you need to open it in the ETS and check whether the IoT Dashboard ETS App has been installed in the ETS.

## 8.5.2 Open a project

If you wish to keep working on an existing project, proceed as follows:

1. In the "Project" tab, click on the "Open project" button to open an existing project.
  - The Windows Explorer opens.
2. Specify the file path under which you have saved the project to be opened.
3. Select the project to be opened.
4. Confirm the selection with a click on "Select folder" to open the project.
  - The project opens in the IoT Dashboard Tool. The building structure is loaded in the navigation.



### Notice

If in the past you have already opened a project in the IoT Dashboard Tool you can select it for fast access from the project list with a click on the arrow in button "Open project". After the selection, the project opens in the IoT Dashboard Tool.

## 8.5.3 Save project

If you wish to save an opened project, proceed as follows:

1. In the "Project" tab, click on the "Save project" button to open an existing project.
  - The opened project will be saved under the memory path you specified during the creation of the project.

## 8.5.4 Project backup

To allow you to restore your project data in case of the loss of data, you should perform a regular backup of your current project.

Fig. 14: Backup / Restoration

Create a backup as described in the following:

1. In the "Project" tab, click on the "Backup..." button.
  - The menu Backup / Restoration IoT Dashboard Server opens.
2. Enter the IP address of the IoT Dashboard Server under Address.
  - If the IP address is unknown to you, you can search for the device and its device information with a click on the Scan button in menu "Found IoT Dashboard Server".
3. Click on option "Create backup".
4. In "File", enter the name under which you want to save your backup (the memory path is assigned automatically), or click on the three points to select a path under which your backup is to be stored.
5. Enable the checkbox "Encrypted file" if your backup is to be encrypted.
  - When the checkbox is enabled, enter a password and confirm it.
6. Finally click on "Proceed".
  - A backup is created for the opened project under the memory path you specified.



### Notice

The "Proceed" button is deactivated when one of the following faults is present:

- Invalid IP address
- Invalid IoT Dashboard Server password
- Invalid encryption password
- Invalid backup file

## 8.5.5 Restore project

In case of a loss of data, you can restore your project data via a backup file. Proceed as follows:

1. In the "Project" tab, click on the "Backup..." button.
  - The menu Backup / Restoration IoT Dashboard Server opens.
2. Enter the IP address of the IoT Dashboard Server under Address.
  - If the IP address is unknown to you, you can search for the device and its device information with a click on the Scan button in menu "Found IoT Dashboard Server".
3. Click on option "Restore from backup".
4. Activate the checkbox of option "Overwrite Project, if different" when the project to be restored is to overwrite the existing project in case of deviations.
5. In "File", enter the name under which you saved your backup (the memory path is selected automatically), or click on the three points and select the memory path under which your backup is stored.
6. Enable the checkbox "Encrypted file" if your backup is an encrypted file.
  - Enter the encryption password and confirm it.
7. Enter the password of your IoT Dashboard Server under Upload password.
  - You can store a different password via the "Change password" button.
8. Finally click on "Proceed".
  - The selected project is restored.



### Notice

The "Proceed" button is deactivated when one of the following faults is present:

- Invalid IP address
- Invalid IoT Dashboard Server password
- Invalid encryption password
- Invalid backup file

## 8.5.6 Close project

You can close an opened project as follows:

1. In the "Project" tab, click on the "Close project" button.
  - The project is closed and you are returned to the start menu.

## 8.5.7 Delete project

To prevent an unintentional deletion, projects can only be deleted via the Windows Explorer and not via the IoT Dashboard Tool.

1. Open the memory path under which you saved your projects via the Windows Explorer.
2. Select the entire project folder you wish to delete.
3. Right-click on the corresponding folder symbol and select the option "Delete".

## 8.5.8 Synchronise project

You have the option of importing a building configuration already stored in an ETS project into the IoT Dashboard Tool. Here you synchronise your project with an existing ETS project.

You can synchronise projects with an ETS project either during their creation (see chapter 8.5.1 “Creating a project” on page 35) or at a later point in time.

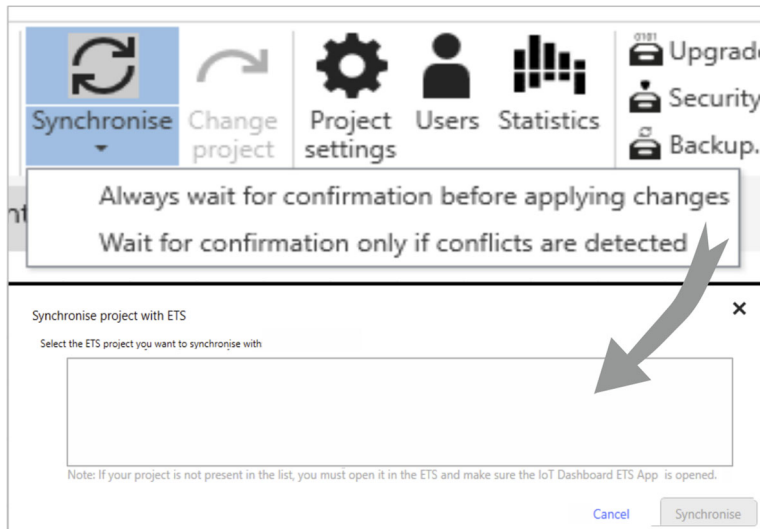

Fig. 15: Synchronising with ETS

To synchronise your project with an ETS project, proceed as follows:

1. In the "Project" tab, click on the arrow in the "Synchronise" button.
  - A drop-down menu opens in which the following two options are available.
    - **"Constantly wait for confirmation before changes are applied".**  
The changes you made are only applied when confirmed.
    - **"Wait for confirmation only when conflicts are detected":**  
The changes you made require confirmation only when there are conflicts with other settings.
  - When you have selected one of the options, the menu "Synchronise project with ETS" opens.



### Notice

Please observe the following points:

- The menu "Synchronise project with ETS" opens only if you have not synchronised your project beforehand with an ETS project.
- It can happen that the menu "Synchronise project with ETS" does not open if you have opened the ETS project in parallel.



2. Select the ETS project with which you want to synchronise your project.
3. Click on "Synchronise".
  - The project is synchronised with the ETS.



**Notice**

If your project is not displayed in the list under "Synchronise project with ETS", you need to check whether the IoT Dashboard ETS App has already been installed in the ETS.

## 8.5.9 Security settings of the ABB i-bus® KNX IoT Dashboard Server

To ensure a secure transmission of data the IoT Dashboard is delivered ex factory with the HTTPS enabled. You can change the security certificate in the security settings on the IoT Dashboard. In addition, you can also enable the data transmission via the unencrypted HTTP.



### Notice

If you enable the HTTP, both the HTTPS and the HTTP are used. Please note that data via the HTTP are transmitted unencrypted, which results in a lower security.

The screenshot shows a dialog box titled "IoT Dashboard Server security" with a close button (X) in the top right corner. The dialog contains the following elements:

- An "Address" input field containing "192.168.2.2".
- A "Found devices" area, which is currently empty.
- An unchecked checkbox labeled "HTTP allowed".
- A "Download CSR" button.
- Text: "To change the HTTPS certificate on the IoT Dashboard Server, you must first obtain a CSR (Certificate Signing Request) from the IoT Dashboard Server."
- An "Upload certificate" button.
- Text: "You must then use this CSR to obtain a signed certificate and send this signed certificate to the IoT Dashboard Server."
- A "Gateway Password" input field with masked characters (dots).
- A checked checkbox labeled "Remember it".
- A "Change password..." button.
- A "Close" button at the bottom center.
- A "Scan" button at the bottom right.

Fig. 16: Security settings

### Activating the HTTP



### Notice

If you enable the HTTP, both the HTTPS and the HTTP are used. Please note that data via the HTTP are transmitted unencrypted, which results in a lower security.

1. In the "Project" tab, click on the "Security..." button.
  - The security settings open.
2. Enter the "IP address" of the device under Address.
3. Enable the checkbox of option "Allow HTTP" if you want to allow the establishing of HTTP connections.
  - To enable the changes, you must upload the project again into the IoT Dashboard Server after changing this parameter.

## 8.5.10 Uploading a project

Upload the project configuration into the IoT Dashboard Server when the following prerequisites have been met:

- The IoT Dashboard Server has been correctly installed.
- Necessary network setting have been performed under the IoT Dashboard Server settings.



### Notice

In the state of delivery both LAN connections of the IoT Dashboard Server are configured in the DHCP mode.

- To ensure that the assigned IP address can be displayed in the IoT Dashboard Tool, the device must be connected to a DHCP server. Scan in the IoT Dashboard Tool, to ensure that the assigned IP address is displayed.
  - Please check your network connection if no device can be found. Both your PC/laptop and the IoT Dashboard Server must be connected in the same IP sub-network. Check the settings of the DHCP server used to see whether it has assigned an IP address to the IoT Dashboard Server . When using a router with an activated DHCP server, please log yourself into the router and check the assigned IP address under "Connected devices". Please contact your system administrator if you have problems in finding the IP address or do not have access rights.
- The project configuration has been completed.

## Uploading the project configuration

Fig. 17: Uploading the project configuration

Upload the project configuration as follows:



### Notice

If you are uploading a project configuration into the IoT Dashboard Server for the first time, or the IoT Dashboard Server was previously reset into the state of delivery, you will be requested to specify an upload password. This password must be entered during every future upload. The upload password can be stored for every upload by activating the "Save" checkbox.

1. In the "Project" tab, click on the "Upload..." button.
  - The window "Upload settings in the IoT Dashboard Server" opens.
2. Click on the Scan button to search for the IoT Dashboard Server .
  - The device including its IP address is displayed.
3. Enter the IP address under "Address" IoT Dashboard Server.
4. There are different procedures during the upload:
  - Set a tick in "Overwrite data during upload" if you want to completely overwrite an existing project configuration (e.g. including alarm history, configured users, etc.)
  - Set a tick in "Options" for each setting that is to be overwritten during the upload of the project configuration. You can overwrite the following settings:
    - Delete alarm history:  
The entire alarm history is deleted
    - Delete scheduler configuration:  
All programmed schedulers are deleted
    - Delete trend data:  
All trend data are deleted

- Delete users:  
All user accounts are deleted
  - Delete all user settings:  
All user settings are deleted
5. Finally click on "Upload".
- The upload starts. The info text "Project is called up from the IoT Dashboard Server" is displayed.
  - The successful upload is displayed in the info text.
6. Finally click on "Close".



### **Notice**

It is possible that the upload fails. There can be several reasons for this:

- The IoT Dashboard Server has not responded within the prescribed time period.
- The connection is faulty since the connected host has not responded.
  - In this case the connection and the remote server must be checked to rectify the fault.
- The software versions of the IoT Dashboard Tool and the IoT Dashboard on the IoT Dashboard Server are not compatible.
  - In this case you need to update the IoT Dashboard on the IoT Dashboard Server or the IoT Dashboard Tool.

## 8.5.11 Project Settings

You can change the project settings under "Project settings" ("Project" tab). The project settings are subdivided in the tabs described below:

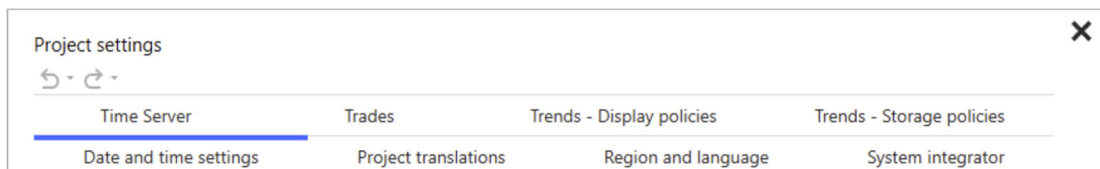

Fig. 18: Project settings

Designation		Function
<b>Date and time settings</b>		In the "Date and time settings" tab a time zone and the type of time synchronisation can be specified.
<b>Functions</b>		In the "Functions" tab, symbols can be assigned to the different standard functions in the IoT Dashboard Tool. In addition, new functions can be created via the "New function" button.
<b>Project translations</b>		In the "Project translations" tab, translations custom designations of building parts, functions, parameters, alarms and descriptions of alarms can be stored.
<b>Region and language</b>		In the "Region and language" tab, weekend days and the geographical position can be specified.
<b>System Integrator</b>		In the "System integrator" tab, contact data of the system integrator can be stored (e.g. name, address, company).
<b>Time server</b>	<b>Features</b>	Under "Properties" it can be specified how data are transmitted to the time server.
	<b>Data points</b>	Under "Data points" the time server can be linked with a field bus point.
<b>Trends - Display policies</b>		Under "Trends - Display policies" it can be specified which elements are to be displayed on the homepage of the IoT Dashboard Tool. A fixed display configuration is already available as standard. The "New policy" button can be used to make additional custom display settings.
<b>Trends - Storage policies</b>		Under "Trends - Storage policies" it can be specified at which interval and under which conditions alarm messages are stored.

Table 6: Project settings

## 8.5.11.1 Date and time settings

### Setting the time zone of the IoT Dashboard Server

The time zone of the IoT Dashboard Server can be set under "Time zone IoT Dashboard Server". Select the appropriate time zone from the drop-down menu.



#### Notice

If the time zone has not been correctly specified via SNTP or via the KNX bus, this can lead to faulty behaviour. For example, if when saving trend data, an incorrect time and an incorrect date are stored, this means that data are displayed in a wrong timescale.

### Synchronising date and time

There are three options available for the synchronisation of date and time:

- Synchronising date / time via SNTP
  - If you want to synchronise data and time via an SNTP, you must enter the server address of the SNTP. The synchronisation requires a permanent network connection.
- Synchronising date / time via KNX bus
  - If you want to synchronise date and time via the KNX bus, you must specify whether different data point types are to be used for date and time and in which format the determined value is to be displayed.
- No synchronisation of date / time
  - If you do not want to synchronise date and time, select this option.

## 8.5.11.2 Project translations

If you use custom designations for building parts, functions, parameters, alarms and alarm descriptions, you can store translations in the IoT Dashboard Tool for all available languages.

You can store translations either manually or via a CSV import.

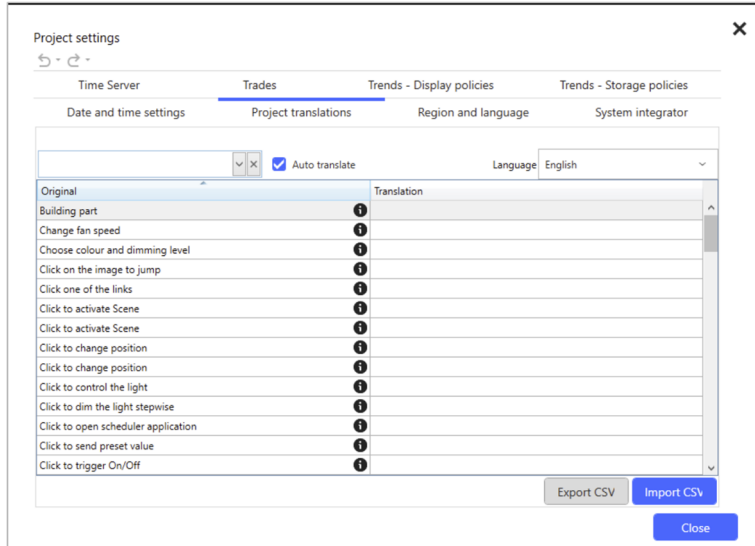

Fig. 19: Project translations

### Storing translations manually

1. Open the "Project translations" tab.
  - In the left column, under "Original", the project string designations of the source language are displayed. In the right column, under "Translation", the translations of the original designations are displayed.
2. Under menu item "Language" select the language from the drop-down menu for which you want to store custom translations.
3. Scroll through the list via the scroll bar or the search function "Apply a filter" (above the source language designations) and select one or several designations for which you want to store a translation.
4. Enter the desired translation.
5. Confirm it with a press of the Enter or Tab key, by clicking on a free area or a click on the "Close" button.



#### Notice

If you have activated the checkbox "Auto translate", all similar designations are translated automatically after the confirmation of a translation.



## Exporting translations in CSV file

1. Click the button "Export CSV".
2. Use "File" to specify the path under which you want to store the export.
3. If you do not want to export all designations, select one of the following options:
  - Enable the checkbox "Export only lines without translation" if only new designations are to be exported.
  - Enable the checkbox "Export only lines which correspond to the current filter", if you want to export only previously filtered designations.
4. Click on "Export".
5. Edit the list in a suitable program (e.g. Microsoft Excel).

## Importing translations from CSV file

1. In the "Project translations" tab, click on the "Import CSV" button.
2. Select the path under which you want to store the CSV file.
3. Enable the checkbox "Update only files without translation" if you want to import only new translations.
4. If you do not want to import all designations, select one of the following options:
  - Enable the checkbox "Update only lines without translation" if only new designations are to be imported.
  - Enable the checkbox "Update only lines which correspond to the current filter", if you want to import only specific designations.
5. Click on "Import".
  - The designations in the source and target language are adjusted.

## 8.5.11.3 Region and language

In the "Region and language" tab, you can specify weekend days and your geographical position. The geographical position you can enter manually under "Manual position", or call up from the KNX bus under "Fetch from bus".

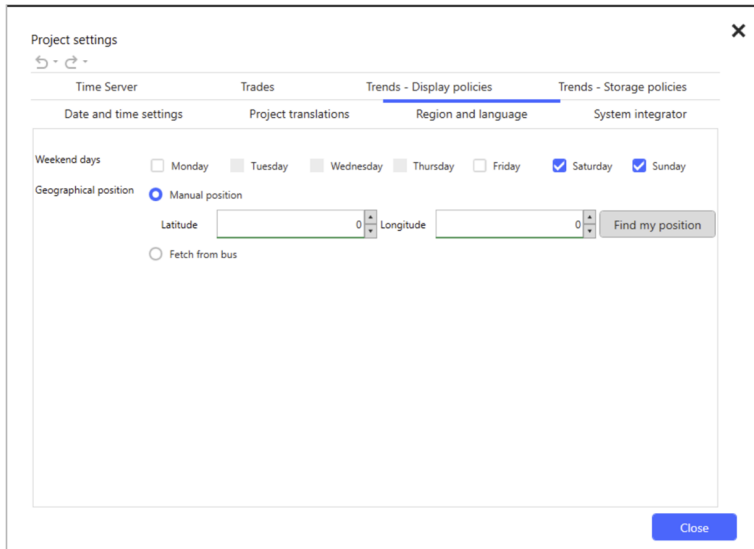

Fig. 20: Region and language

### Weekend days

1. Set a tick for all weekend days you want to define as weekend day.
  - You can select a maximum of three days.

### Manual position

1. Under "Geographical position" select the option "Manual position".
2. Enter your position data under latitude and longitude.
  - If you do not know your geographical position, you can call it up via button "Find my position".
3. Then click on "Close".

### Fetch from bus

1. Under "Geographical position" select the option "Fetch from bus".
2. Assign the correct field bus points to data points "DP longitude" and "DP latitude".
  - Your geographical position is determined via the data points.
3. Then click on "Close".

## 8.5.11.4 System Integrator

To be able to contact the electrical installer in case of problems, the following contact data should be stored:

- Name
- Company
- City
- Street
- Country
- E-mail
- Phone number

## 8.5.11.5 Time server

Under "Properties" you can make settings on the Time server properties, such as specifying send intervals and define the behaviour during reboot.

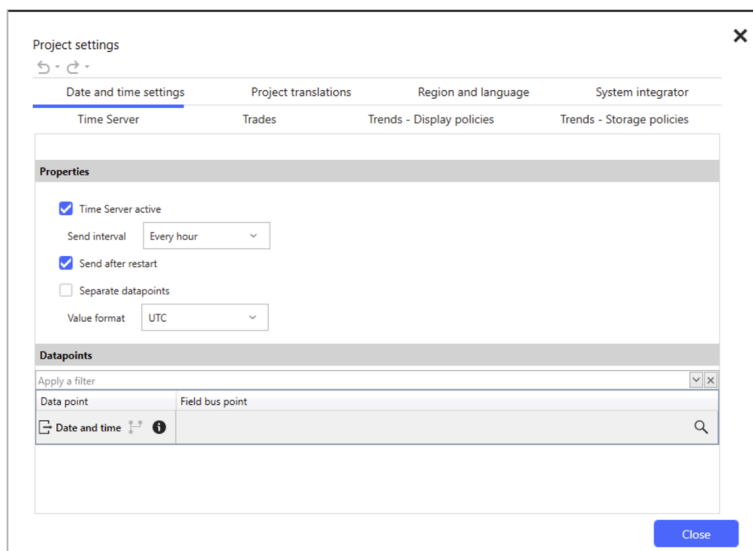

Fig. 21: Time server

### Specifying send interval

1. Under "Project settings" in the "Time server" tab, activate the checkbox "Time server active" and specify a send interval.
  - The following selection options are available:

Options:	Hourly
	Twice daily
	Once daily
	Once weekly
	Once monthly

## Behaviour during reboot

1. Enable the checkbox "Send after restart" when the time server is to determine the time during each reboot.

## Use individual data points

1. Enable the checkbox "Individual data points" when date and time is to be sent via individual data points.

## Specifying time format

1. Specify the time format.
  - The following selection options are available:

Options:	UTC
	Local time (with daylight)
	Local time (without daylight)

## Data points

You must assign the corresponding group addresses under "Data points". The number of data points that are available depends on the settings you made under "Individual data points".

1. If you use individual data points, the following data points are available:

Options:	Date
	Time

2. When you use a joint data point, the following data point is available:

Options:	Date and time
----------	---------------

## 8.5.11.6 Functions

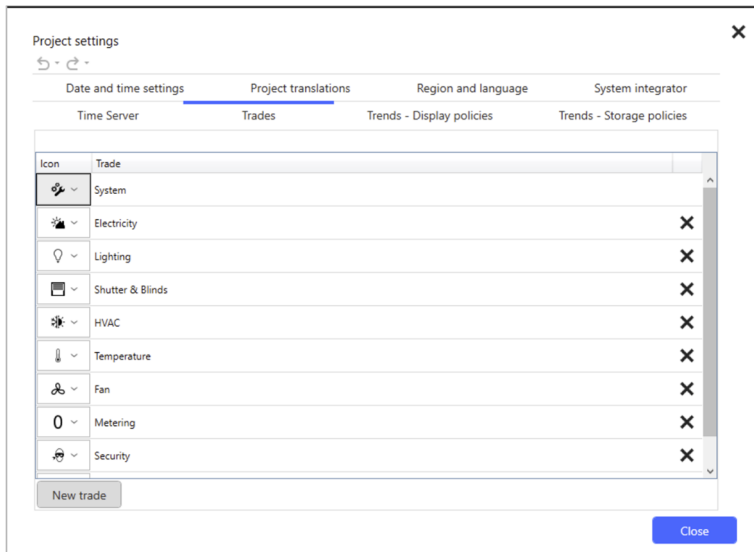

Fig. 22: Functions

The following functions are predefined:

- System
- Electricity
- Lighting
- Blind and Shutter
- HVAC
- Temperature
- Fan
- Metering
- Security
- Emergency
- Trade

The missing functions can be created anew via the "New function" button.

## **Changing / deleting existing functions**

Proceed as follows to change or delete existing functions:

1. Open the project settings.
2. Select the "Functions" tab.
3. In the "Symbol" column click on the arrow on the right next to the symbol that you want to change.
4. Navigate through the different symbols with the scroll bar and select the desired symbol.
5. Then click on an empty area to take over you selection.
6. Make a double or a right-click on the entries in column "Function" and assign, if desired, a different function name.
7. Click on the cross symbols on the right of the function designation to delete any entry.

## **Creating additional functions**

:Proceed as follows to create additional functions for custom scenarios.

1. Open the project settings.
2. Select the "Functions" tab.
3. Click on "New function".
  - A new preset line is created.
4. Assign the function in the line any symbol and designation.
  - Proceed as described under Changing / deleting existing functions.

### 8.5.11.7 Trends - Display policies

In the "Trends - Display policies" tab you can define display policies for the "Trend viewer" control (see chapter 9.15 "Control "Trend viewer"" on page 177). The display setting "Standard display" is preconfigured as standard, with which all elements in the "Trend viewer" control are displayed with the exception "Display weekends".

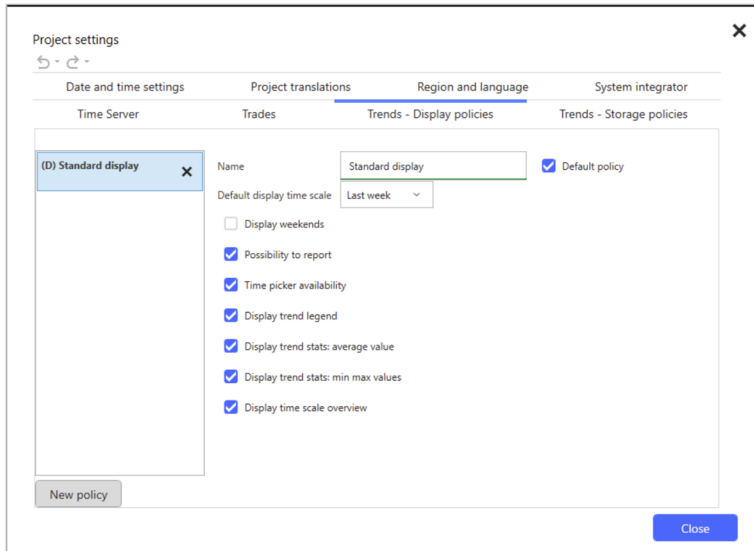

Fig. 23: Trends - Display policies

#### Adding new display policy

1. Click on the "New policy" button to add a new display setting for the "Trend viewer" control.
  - The setting is added as "New policy" to the list.
2. Then define the policy on the basis of the options listed in the following.

- **Name**

Name:	Name of the setting
-------	---------------------

The name of the display setting is specified via the option. Each name must only be assigned once.

- **Default policy**

Options:	Disabled
	Enabled

A policy is specified as default policy via the option.

- **Default display timescale**

Options:	Yesterday
	Today
	Last 3 months
	Last 6 months
	Last Week
	Last Month
	Last Year

The option is used to specify the timescale that is to be displayed in the "Trend viewer" control.

- **Display weekends**

Options:	Disabled
	Enabled

When the option is enabled, the days of the week, which correspond to the weekends, are highlighted in the control.

- **Possibility to report**

Options:	Disabled
	Enabled

The option is used to specify whether the data are allowed to be transmitted.

- **Time picker availability**

Options:	Disabled
	Enabled

When the option is enabled, the default display timescale can be changed in the "Trend viewer" control.

- **Display trend legend**

Options:	Disabled
	Enabled

The option is used to specify whether a legend is to be displayed in the "Trend viewer" control.

- **Display trend stats: average value**

Options:	Disabled
	Enabled

When the option is enabled, average values are displayed in text format in the "Trend viewer" control.



- **Display trend stats: min max values**

Options:	Disabled
	Enabled

When the option is enabled, minimum and maximum values of the trend statistics are displayed in text format in the "Trend viewer" control.

- **Display timescale overview**

Options:	Disabled
	Enabled

When the option is enabled, a timescale overview is displayed in the lower area of the "Trend viewer" control, which the user can adjust.

### Copying display settings

1. In the "Trends - Display policies" tab in the left area, click on a display setting you want to copy.
2. Copy the policy with the CTRL+C button combination.
3. Insert the policy with the CTRL+V button combination.
  - The policy is added to the list with the name of the copied setting and the suffix "(Copy)".
4. If necessary, make all the desired settings.

### Delete display settings

1. In the "Trends - Display policies" tab in the left area, select a display setting you want to delete.
2. Click on the X symbol.
  - The display setting is removed.



**Notice**

If you try to remove a policy that is used by at least one control, the fault message "Setting cannot be deleted" is displayed.



**Notice**

If you delete the default policy, the following policy is automatically fixed as default policy.

### 8.5.11.8 Trends - Storage policies

In the "Trends - Storage policies" tab it can be specified at which interval and under which conditions trends are stored.

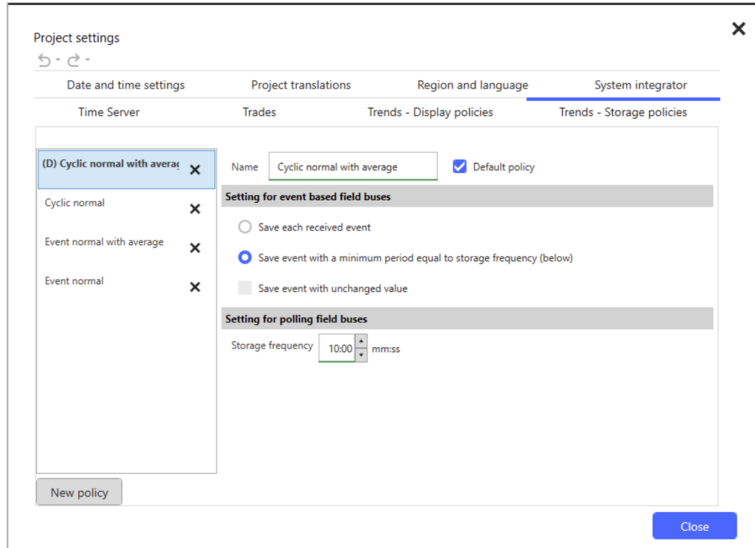

Fig. 24: Trends - Storage policies

The following predefined storage settings are available:

- Cyclic normal with average (default setting)
- Cyclic normal
- Event normal with average
- Event normal
- New policy (previous click on the "New policy" button)

#### Adding storage policy

1. Click on the "New policy" button to add a new storage policy for the "Trend viewer" control.
  - The setting is added as "New policy" to the list.
2. Then define the policy on the basis of the options listed in the following.

- **Name**

Name	Name of the setting
------	---------------------

The name of the storage policy is specified via the option. Each name must only be assigned once.

- **Default policy**

Options:	Disabled
	Enabled

A policy is specified as default policy via the option.

- **Setting for event based fieldbuses**

Options:	Save each event
	Save event with unchanged value
	Save event when the minimum period equals the storage frequency (below)

- Save each event:
  - If this option is selected, each event is saved in the trend database.
- Save event when the minimum period equals the storage frequency (below)
  - If this option is selected, each value received on the fieldbus will only be stored when a minimum period of time that was previously specified has expired since the last stored event. This minimum period corresponds to the storage frequency. (see Trends - Storage policies).

- **Save event with unchanged value**

Options:	Disabled
	Enabled

- Disabled:
  - When the option is disabled, only events that are different from the last stored even will be stored.
- Enabled:
  - When the option is enabled, each event is stored also when the values are the same.



**Notice**

The option can only be set when the option "Save each event" has been selected.

- **Setting for polling fieldbuses**

**Storage frequency**

Options:	1 - 60 (mm:ss)
----------	----------------

This option specifies the time interval during which values are to be polled on the fieldbus and saved.

## Copying storage policies

1. In the "Trends - Storage policies" tab, click on a storage policy in the left area that you want to copy.
2. Copy the policy with the CTRL+C button combination.
3. Insert the policy with the CTRL+V button combination.
  - The policy is added to the list with the name of the copied setting and the suffix "(Copy)".
4. If necessary, make all the desired settings.

## Deleting storage policies

1. In the "Trends - Storage policies" tab, select a storage policy in the left area that you want to delete.
2. Click on the X symbol.
  - The storage policy is deleted.



### Notice

If you try to remove a policy that is used by at least one control, the fault message "Setting cannot be deleted" is displayed.



### Notice

When you delete the default storage policy, the following policy is automatically fixed as default policy.

## 8.5.12 Symbols library

The "Symbols library" tab comprises all available symbols which can be assigned to the different controls in the "Parameter" area. The symbols represent different actions within prescribed function categories. Aside from the existing symbols, you can also add custom symbols to the symbols library. The symbols library is subdivided into the following function categories:

- Custom
- Communication
- Energy
- Function
- Lighting
- Multi-media
- Navigation
- Notifications
- Object
- Location
- Scene
- System
- Temperature
- Window and door

You can enlarge symbol viewers in the symbols library by turning the mouse wheel.

### Adding custom symbol

If you require special symbols in your project, you can add custom symbols to the symbols library. As soon as you have added a custom symbol, it is listed in a new "Custom" category.



#### Notice

Custom symbols are valid project-specific only for the respective project to which it was added.

You have two possibilities to add custom symbols to the symbols library.

1. Open the "Symbols library" tab.
2. In the Windows Explorer select any image and pull it into the symbols library via drag and drop.
  - The image is added to the symbols library when the picture is released.

Alternative:

1. Click on the plus sign at the top right edge of the symbols library.
2. In the Windows Explorer select any image and click on "Open".
  - The image is added to the symbols library.



#### Notice

Added images receive the name of the original file. If the name has already been assigned, a different name is generated automatically.  
Existing images are not added to the symbols library.

## Add symbol to the control

1. Select a control whose button you want to define or add an image to (e.g. control "Image").
2. Change to the "Parameter" area of the control.
3. Open the "Symbols library" tab.
4. Select a symbol from the different categories.
5. Pull the symbol from the symbols library to the desired symbol parameter via drag and drop.
  - The symbol is adjusted when released.

## Filtering symbols

Each symbol responds to key terms by which the symbols can be filtered.

1. Enter a key term in the search line of the symbols library or click on the arrow to select a key term from a preselection.
  - Then all symbols that have been assigned to the key term are displayed.

## Delete symbol

You can delete custom symbols via the x button.



### Notice

When a symbol is used by a parameter, a warning is displayed and the symbol cannot be deleted.

## 8.5.13 Software information

General software information is summarised in the Project tab under the Info button. Clicking on the button opens an information box that contains the following information:

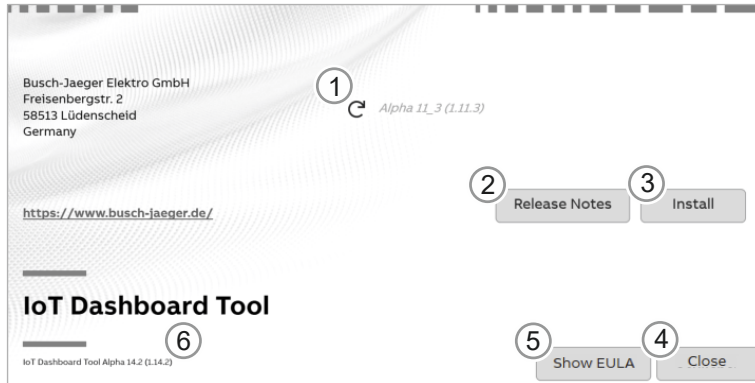

Fig. 25: Information menu

Pos.	Function	Description
[1]	Cloud version of the IoT Dashboard Tool	Displays the Cloud version of the IoT Dashboard Tool . The version can be updated with a click on the arrow. If the server cannot be accessed, a message is displayed and the buttons "Release Notes" and "Install" are disabled.
[2]	Release Notes	The button is used to open the release notes in the browser on the current version of the IoT Dashboard Tool . The button is disabled when there is no access to Cloud.
[3]	Install	The button is used to load the setup file for the IoT Dashboard Tool and copy it to the hard disk. The button is disabled if the version in Cloud and the currently installed IoT Dashboard Tool are the same.
[4]	Display EULA	The button is used to open the current end user license agreement.
[5]	Close	This button is used to close the information menu.
[6]	Version of the IoT Dashboard Tool	Displays the currently installed version of the IoT Dashboard Tool .

## Download and install the setup file

1. Click on "Install" in the information menu.
2. Specify a memory path under "Save at".
  - The setup file is stored under this path.
3. Confirm with a click on "Save".
  - The setup file is downloaded.
  - The installation starts automatically after the download.



### Notice

The project may have to be saved prior to the installation, because the IoT Dashboard Tool must be closed before the setup.



### Notice

You can basically install every version from Cloud since several versions of the IoT Dashboard Tool can be installed simultaneously.



## 8.5.14 Other Project settings

A number of additional settings can be made in the "Project" tab. These are described in the following.

### Layout

When you have personalised the layout of the IoT Dashboard Tool, you can save or reset your personal settings.

1. In the "Project" tab, click on "Layout".
  - The options "Save layout" and "Reset layout" are available.
  - Click on the desired option.
2. Proceed as follows to save a layout.
  - Click on "Save layout".
  - Enter the name of the layout in window "Add layout".
  - Click on "OK".
3. Proceed as follows to reset a layout.
  - Click on "Reset layout".
  - The layout is reset.

### Language

The language of the IoT Dashboard Tool can be changed at any time via the "Language" button.

1. In the "Project" tab, click on the "Language" button.
2. Select the desired language in the drop-down menu.
3. Confirm the selection of your choice by clicking on "Change" or "Change and restart".
  - Please note that changes become effective only after a reboot (option "Change and reboot").



### Notice

During the first start of the IoT Dashboard Tool the software checks whether the language of the operating system is supported by the IoT Dashboard Tool. If yes, then the language of the operating system is fixed as the standard language. If not, then English is fixed as the standard language.

### Statistics

The "Statistics" button is used to view the general statistics about the project. The statistics contain information about:

- Number of created user accounts
- Number of elements in building topology
- Number of operating pages
- Number of controls
- Number of controls per type
- Number of configured alarms
- Number of data points configured in trends

## **Network settings**

The network settings of the IoT Dashboard Server can be viewed and changed in the "Project" tab with the "Settings" button. To ensure that your changes of the network settings are taken over, you must upload them into the IoT Dashboard Server.

1. In the "Project" tab, click on the "Settings" button.
  - The "IoT Dashboard Server settings" menu opens.
2. Make the desired settings changes to the settings.
3. Click on button "Upload settings" to take the settings over.

## 8.6 User rights

User groups and corresponding users can be created in the "Project" tab under "Users". All users and user groups can be assigned individual user rights. The following user groups and user rights are available as standard:

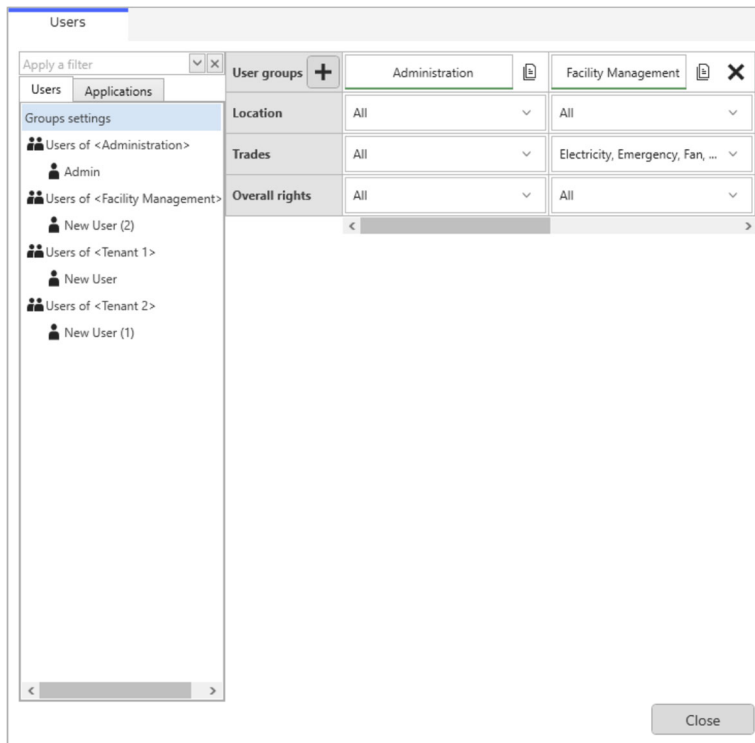

Fig. 26: Managing user right

### User Groups

- Administration
- Facility Management
- Tenant 1
- Tenant 2

### User rights

- Location:

In the "Location" area you specify the building parts (building, corridor, floor, room, stairs, distribution cabinet, custom) to which the different user groups or users are to have access. The building parts for which user rights can be defined depends on the navigation structure (see chapter 8.7 "Creation of the navigation structure" on page 73).

1. Set a tick in the "Location" area at all building parts for every user group or every user to which access is to be granted.

## ▪ Functions

In the "Functions" area you specify the functions to which the different user groups or users are to have access. The functions for which user rights are to be defined depends on the functions created previously in the project settings (for available functions, see chapter 8.5.11 "Project Settings" on page 46).

1. Set a tick in the "Functions" area at all functions for every user group or every user to which access is to be granted.

## ▪ Overall rights

In the drop-down menu "Overall rights" the rights that are to be valid for which user groups or users can be specified.

1. Open the drop-down menu in the "Overall rights" area.
  - A list with several options opens.
2. Set a tick at each option for which the affected user group or user is to receive rights.

The following general rights can be assigned:

Authority	Description
All	The user group has all general rights available.
Able to create backups for IoT Dashboard projects	Allows the user to create backups for IoT Dashboard projects.
Able to manage system settings	Allows the user to manage system settings.
Able to receive notifications	Allows the user to receive notifications.
Able to IoT Dashboard-Projekte wiederherstellen	Allows the user to restore IoT Dashboard projects.
IoT Dashboard Tool can be registered in MyBuildings	Allows the user to register the IoT Dashboard Tool in the MyBuildings .
Able to display alarms	Allows the user to display alarms.
Able to acknowledge alarms	Allows the user to acknowledge alarms.
Able to delete alarms history	Allows the user to dele the alarm history.
Able to change/create/delete user groups	Allows the user to change/create/delete user groups.
Able to display user groups and users accounts	Allows the user to display user groups and user accounts.
Able to change/create/delete user accounts	Allows the user to change/create and delete user groups.
Able to run a sequence	Allows the user to run a sequence.
Able to start a scene	Allows the user to start a scene.
Able to display and manage IoT Dashboard applications	Allows the user to display and manage v>T - 05_Software -- IoT Dashboard</v> applications.
Able to send writing command on the bus	Allows the user to send writing commands on the bus.
Able to access trends	Allows the user to access trend data.
Able to delete trends	Allows the user to delete trend data.
Able to export trend values	Allows the user to export trend values.

## Commissioning via ABB i-bus® KNX IoT Dashboard Tool

Able to display schedulers	Allows the user to display schedulers.
Able to modify schedulers	Allows the user to modify schedulers.
Able to deactivate schedulers	Allows the user to deactivate schedulers.

Table.7: Available overall rights

## 8.6.1 Rights of user groups

User groups can be created in the "Project" tab. Each user group can be assigned individual rights.

### Add user group

1. Open the user administration with a click on the "Users" button.
2. In the left area of the user administration in the "Users" tab, click on the option "Group settings".
3. In the "User groups" column, click on the plus symbol.
  - A new user group is added to the list.
4. Adjust the name of the user group with a click on the text field.
5. Specify which rights the new user group is to have (see chapter 8.6 "User rights" on page 67).

### Copy user group

1. Select a user group you want to copy.
2. Click on the document symbol next to the user group.
  - A copy of the user group is added to the list.
3. Make adjustments, if necessary.

### Delete user groups

1. Select a user group you want to delete.
2. Click on the black cross next to the user group.
  - The user group is deleted.



#### Notice

You can delete all user groups with the exception of the "Administration" user group.

### 8.6.2 Rights of users

Individual users can be created within an existing user group in the "Project" tab under "Users". Individual rights can be assigned to each user.

The screenshot shows the 'Benutzer' (Users) configuration window. On the left, there is a list of user groups under 'Benutzer' and 'Applikationen'. The selected group is 'Benutzer von <Administration>' with the user 'Admin' selected. The main area shows the configuration for this user:

Benutzer von <Administration>		Admin
Anmeldedaten	Passwort	.....
	Initialen	
	E-Mail	
Gültigkeit	Automatisches Abmelden bei Inaktivität	<input checked="" type="checkbox"/>
	zu	Datum auswählen <input type="text" value="15"/>
	An	Datum auswählen <input type="text" value="15"/>
Standort		Alle
Funktionen		Alle
Allgemeine Rechte		Alle

Buttons: Filter eingeben, +, Schließen

Fig. 27: Rights of users



#### Notice

Even though the rights for a user group have been specified, the rights for individual users within a user group can deviate from them.

## Add user

1. Open the user administration with a click on the "Users" button.
2. In the left area of the user administration in the "Users" tab, select a user group "Users of <x>".
  - All existing users are displayed below the user group "Users of <x>" and in the right area of the user administration.
3. In the "Users of <x>" column, click on the plus symbol.
  - A new user is added to the list.
4. Adjust the name of the user with a click on the text field.
5. Assign a user password under "Credentials"
  - Ensure that your password meets the standards for maximum security.
6. Store the user initials as well as the e-mail address.
7. Set a tick at "Automatic logout at inactivity" when the affected user is to be logged out automatically during inactivity.
8. Specify a period under "From" and "To" within which the user is to be valid.
9. Specify the rights the new user is to have available (see chapter 8.6 "User rights" on page 67).

## Copy Users

1. Select a user you want to copy.
2. Click on the document symbol next to the user.
  - A copy of the user is added to the list.
3. Make adjustments, if necessary.

## Delete users

1. Select a user you want to delete.
2. Click on the black cross next to the user.
  - The user is deleted.



### Notice

You can delete all users with the exception of "Admin" user.



## 8.7 Creation of the navigation structure

A navigation structure can be created in the IoT Dashboard Tool which fully depicts the building topology. The building is subdivided into building, building parts, floors, corridors, staircases and rooms. Each element of the building structure is displayed as independent operating page. In addition, distribution cabinets can be positioned in the individual operating pages of the navigation structure.

The starting point for the creation of the navigation structure is the area "Navigation" on the homepage of the IoT Dashboard Tool.

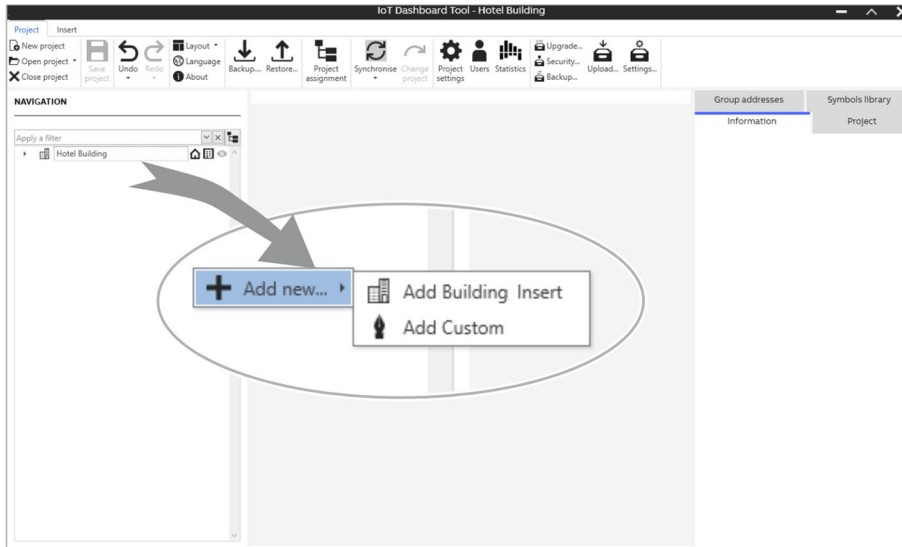

Fig. 28: Creating the navigation structure

## 8.7.1 Architectural and template mode

The navigation structure can be created and displayed in different modes:

### Architectural mode

In the architectural mode the elements are represented in a building architecture.

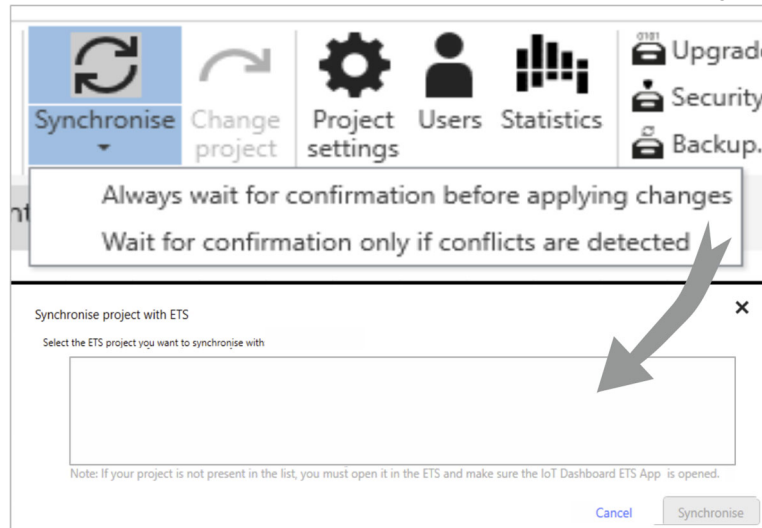

### Template mode

In the template mode the elements are grouped per template. In addition, also all elements to which no template was assigned are displayed.

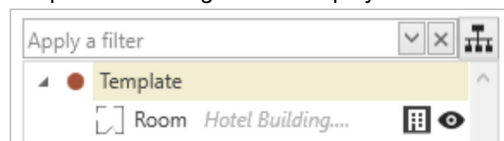

Table 8: Modes of the navigation structure

The difference during editing a template compared to editing an element in the building structure is that assignments (see chapter 9.31 “General assignment“ on page 275) are not displayed and that functions within a template cannot be changed.

### Change mode

The change into another mode happens with a click on the symbol at the top right (see graphics in table “Modes of the navigation structure“ on page 74) in the navigation tree

The creation of the navigation structure is described in detail in the following.



### Notice

The function of the right mouse button during the creation of the navigation structure depends on the mode selected beforehand.

## 8.7.2 Filter functions

The navigation tree has its own filter function. The elements of the building architecture can be filtered via the filter element in the top area of the navigation tree.

The filter is used to filter elements on the basis of their designation within the building structure. In the template mode filtering can also take place according to the designation of a template. If one or more filters are active, only elements that were filtered are displayed.



### Notice

If a subordinate element corresponds to the set filter and the overriding element has been differently named, it is nevertheless displayed in the navigation tree (applies to elements of the building architecture and templates).

### Create filter

1. Click on the filter menu in the navigation.
2. Enter the designation of an element or a template according to which you want to filter.
3. Confirm with "Enter" or a click in the navigation tree.
  - Now only the elements/templates affected by the filter are displayed in the navigation.

### Delete filter

1. Select the filter in the filter menu that you want to delete.
2. Click on the "x" next to the filter.
  - The filter is deleted.

## 8.7.3 Project templates

Templates can be used within the navigation and project tree. If a new element is added to the building architecture, a new or an existing template can be added to it.

All changes that are made to an element which is based on a template, also have an effect on all others that are linked with the building parts.

During the creation of the navigation structure, templates can be added to the building and to the different elements. You have the option of adding an "Existing template" or a "New template" to the respective element.

You create a new template either during the creation of buildings or elements in the building architecture in the architectural mode or template mode.

### Create a new template in the architectural mode

Proceed as follows if you wish to create a new template:

1. Change into the architectural mode.
2. Create any kind of element in the building structure (see chapter 8.7 "Creation of the navigation structure" on page 73).
3. Select the option "New template" under "Template" during the creation of the affected element.
4. Assign a name.
  - The name is limited to 30 characters.
  - A valid name is marked with a green line.
  - A name that is already used is marked with a red line.
5. Select a colour.
  - The template is marked in the navigation or project tree with the selected colour.

### Create a new template in the template mode

Proceed as follows if you wish to create a new template:

1. Change into template mode in the "Navigation" area.
2. Make a right click in an empty area.
3. Click on the option "Add new template".
4. Assign a template name under "Name".
  - The name is limited to 30 characters.
  - A valid name is marked with a green line.
  - A name that is already used is marked with a red line.
5. Select a colour.
  - The template is marked in the navigation or project tree with the selected colour.
6. Select the template symbol.
7. Click on "Add".

## Edit template

Templates can be edited in the template mode. To do this, proceed as follows:

1. Change into the "Navigation" area.
2. Change into template mode.
3. Select a template.
4. Change into the "Information" tab.
  - Here you can edit the template.
5. If necessary, you can assign a new name, select a different template symbol or a different colour.

## Linking the template with functions/applications

You can link the selected template with functions and/or applications (for general information see Chapter 8.7 "Creation of the navigation structure" on page 73, Chapter 8.8 "Configuration of the operating pages" on page 89 and Chapter 9.28 "Configuration of applications and application pages" on page 245). This action is possible both via the architectural and template mode.

1. Change into the "Navigation" area.
2. Select a mode.
3. Select a template.
  - Select an element in the architectural mode to which a template has been assigned.
  - Select any template in the template mode.
4. Open the "Information" tab.
5. Change into the "Project" tab or into the "Paste" tab.
6. Pull any function into the "Content" area of the "Information" tab via drag and drop.
  - The selected template is assigned to the function.

## Copy the template and paste it

Templates can only be copied in the template mode. Proceed as follows:

1. Change into the "Navigation" area.
2. Change into template mode.
3. Select one or several templates (by keeping the CTRL button pressed).
4. Make a right click on the template(s) and select the "Copy" option, or, alternatively, use the "CTRL+C" button combination.
5. Make a right click on the template(s) and select option "Paste", or, alternatively, use the "CTRL+V" button combination.
  - The template is inserted as copy with a generic name.



### Notice

When copying a template, the building parts are not copied into the template, only the template itself.

## Delete template

Templates can only be deleted in the template mode. Proceed as follows:

1. Change into the "Navigation" area.
2. Change into template mode.
3. Select one or several templates (by keeping the CTRL button pressed).
4. Make a right click on the template(s) and select the "Delete" option, or, alternatively, use the "DEL" button.
  - The dialogue "Delete templates(s)" opens.
5. Confirm the enquiry with a click on "Yes".



### Notice

If there are elements based on the template to be deleted, the message is displayed in the dialogue that the deletion of the template(s) also deletes the elements and subordinate elements that are based on the selected template. Here you can select the elements that are to be deleted with a click in the dialogue window.

### 8.7.4 Creating operating pages for buildings

Fig. 29: Adding buildings

1. Click on the free space in the "Navigation" area with the right mouse button.
  - A window with a plus sign and the text "Add new..." opens.
2. Click on the option "Add new...".
  - A selection menu opens with the options "Add building" and "Add custom".
3. Select the option "Add building".
  - The "Add building" dialog opens. Here you can create the building operating page.
4. Assign a name.
5. Specify under "Number to add" how many buildings are to be added.
6. Specify under "Template" whether a project template is to be used, or, alternatively, create a new template.
7. Specify under "Synchronised with ETS" whether the element is to be synchronised with the ETS.
8. Click on "Add".

#### Managing multiple buildings

If you want to manage several buildings in the navigation structure, you must specify the order of priority and the names of the individual buildings.

1. Specify under "Number to add" the number of buildings to be added.
2. Adjust the names of the buildings in the "Name" line.
3. Specify the "Rank of the first element" in the first position of the order of priority (or the first building).
  - Use the (*rank*) marker in the "Name" line behind the respective name to specify the position of the order of priority.

## Creating building parts

If your building is subdivided into several building parts, you can illustrate this in the IoT Dashboard Tool. Proceed as follows:

1. Click in the "Navigation" area with the right mouse button on the building created beforehand.
  - A window with a plus sign and the text "Add new..." opens.
2. Click on the text "Add new..."
  - A selection menu with several options opens.
3. Select the option "Add building part".
  - The "Add building parts in <Building X>" dialog opens. Here you can create the building part.
4. Assign a name.
5. Specify under "Number to add" how many building parts are to be added.
6. Specify under "Template" whether an existing template ("Existing template") is to be used, or create a new template ("New template").
7. Specify whether the element is to be synchronised with the ETS ("Synchronised with ETS").
8. Click on "Add".
9. If you want to manage several building parts, proceed as described under "Manage multiple buildings" (See page 79).



## 8.7.5 Creating operating pages for floors

As soon as you have created your building(s) and, if necessary, building parts, you can further define the building topology.

In the following you should specify the number of floors you require. Floors can only be assigned to a building or to a building part. Proceed with the assignment as follows:

1. Click in the "Navigation" area with the right mouse button on a building or a building part
  - A window with a plus sign and the text "Add new..." opens.
2. Click on the option "Add new...".
  - A selection menu opens with the options "Add building part", "Add floor", "Add staircase", "Add corridor", "Add room" and "Add custom".
3. Select the option "Add floor".
  - The "Add building(s) in <X>" dialog opens. Here you can create one or several floors.
4. Assign a name.
5. Specify under "Number to add" how many floors are to be added.
6. Specify under "Template" whether an existing project template is to be used, or create a new template.
7. Specify under "Synchronised with ETS" whether the element is to be synchronised with the ETS.
8. Click on "Add".
9. If you want to manage several floors, proceed as described under "Manage multiple buildings" (See page 79).

## 8.7.6 Creating operating pages for staircases

In the following you should specify the number of staircases you require. Staircases can only be assigned to a building or to a building section. Proceed with the assignment as follows:

1. Click in the "Navigation" area with the right mouse button on a building or a building part.
  - A window with a plus sign and the text "Add new..." opens.
2. Click on the option "Add new...".
  - A selection menu opens with the options "Add building part", "Add floor", "Add staircase", "Add corridor", "Add room" and "Add custom".
3. Select the option "Add staircase".
  - The "Add staircase(s) in <X>" dialog opens. Here you can create one or several staircases.
4. Assign a name.
5. Specify under "Number to add" how many staircases are to be added.
6. Specify under "Template" whether an existing project template is to be used, or create a new template.
7. Specify under "Synchronised with ETS" whether the element is to be synchronised with the ETS.
8. Click on "Add".
9. If you want to manage several staircases, proceed as described under "Manage multiple buildings" (See page 79).

## 8.7.7 Creating operating pages for corridors

In the following you should specify the number of corridors you require. Corridors can be assigned to a building or to a building part as well as floors.

Proceed with the assignment of corridors as follows:

1. Click in the "Navigation" area with the right mouse button on a building or a building part
  - A window with a plus sign and the text "Add new..." opens.
2. Click on the option "Add new...".
  - A selection menu opens with the options "Add building part", "Add floor", "Add staircase", "Add corridor", "Add room" and "Add custom".
3. Select the option "Add corridor".
  - The "Add corridor(s) in <X>" dialog opens. Here you can create one or several floors.
4. Assign a name.
5. Specify under "Number to add" how many buildings or building parts are to be added.
6. Specify under "Template" whether an existing project template is to be used, or create a new template.
7. Specify under "Synchronised with ETS" whether the element is to be synchronised with the ETS.
8. Click on "Add".
9. If you want to manage several corridors, proceed as described under "Manage multiple buildings" (See page 79).

## 8.7.8 Creating operating pages for rooms

In the following you should specify the number of rooms you require. Rooms can be assigned to a building or to a building part as well as floors.

Proceed with the assignment of rooms as follows:

1. Click in the "Navigation" area with the right mouse button on a building, a building part or a floor.
  - A window with a plus sign and the text "Add new..." opens.
2. Click on the option "Add new...".
  - A selection menu with different options opens. The list of the options depends on the node type to which a building part is to be added.
3. Select the option "Add room".
  - The "Add room(rooms) in <X>" dialog opens. Here you can create one or several rooms.
4. Assign a name.
5. Specify under "Number to add" how many rooms are to be added.
6. Specify under "Template" whether an existing project template is to be used, or create a new template.
7. Specify under "Synchronised with ETS" whether the element is to be synchronised with the ETS.
8. Click on "Add".
9. If you want to manage several rooms, proceed as described under "Manage multiple buildings" (See page 79).

## 8.7.9 Creating operating pages for distribution boards

For the optimum representation of your building you can add distribution boards to the navigation structure. Distribution boards can be assigned to corridors, rooms and staircases.

Proceed with the assignment of distribution boards as follows:

1. Click in the "Navigation" area with the right mouse button on a corridor, a room or a staircase.
  - A window with a plus sign and the text "Add new..." opens.
2. Click on the option "Add new...".
  - A selection menu opens with the options "Add distribution board" and "Add custom".
3. Select the option "Add distribution board".
  - The "Add distribution board(s) in <X>" dialog opens. Here you can create one or several distribution boards.
4. Assign a name.
5. Specify under "Number to add" how many distribution boards are to be added.
6. Specify under "Template" whether an existing project template is to be used, or create a new template.
7. Specify under "Synchronised with ETS" whether the element is to be synchronised with the ETS.
8. Click on "Add".
9. If you want to manage several distribution board, proceed as described under "Manage multiple buildings" (See page 79).

## 8.7.10 Creating custom operating pages

The operating pages available as standard for the configuration of the navigation structure cannot always illustrate all real building structures. In such a case, a custom operating page should be configured.

For the creation of the custom operating pages, proceed as follows:

1. Click on the free space in the "Navigation" area with the right mouse button.
  - A window with a plus sign and the text "Add new..." opens.
2. Click on the text "Add new..."
  - A selection menu with the familiar options opens.
3. Select the option "Add custom".
  - The "Add custom in <X>" dialog opens. Here you can create the building operating page.
4. Assign a name.
5. Assign one of the available symbols to the operating page.
6. Specify under "Number to add" how many custom operating pages are to be added.
7. Specify under "Template" whether an existing project template is to be used, or create a new template.
8. Click on "Add".



### Notice

Since the custom operating pages cannot be stored in advance in the ETS, there is no possibility to synchronise them via the ETS.

## 8.7.11 Editing the navigation structure

### Renaming the element of the building architecture

1. In the "Navigation" area, click with the right mouse button on the element you want to rename and click on "Rename". Or double click on the element or press the F2 key on your keyboard.
  - The element you want to rename is marked.
2. Adjust the name and confirm with a click on the free space or press on the "Enter" button.

### Copying and pasting the element of the building architecture

1. In the "Navigation" area, click with the right mouse button on the element you want to copy.
  - The selection menu opens.
2. Click on "Copy". Or press the "CTRL+C" button combination on your keyboard (this only works if you have selected the element beforehand).
3. Select a position in the building architecture to which you want to copy the element and make a right click.
  - The selection menu opens.
4. Click on "Paste". Or press the "CTRL+V" button combination on your keyboard.

### Deleting the element of the building architecture

1. In the "Navigation" area, click with the right mouse button on the element of the building architecture that you want to delete.
  - The selection menu opens.
2. Click on "Delete". Or press the "DEL" button on your keyboard.
  - The element is deleted.

## 8.7.12 Editing operating pages

### Editing/rename page

1. In the "Navigation" area, click on the element whose operating page you want to rename.
2. In the "Tiles" tab of the associated operating page, click on the page name.
  - A pin symbol is displayed next to the page name.
3. Click on the pin symbol.
  - The menu "Page editing" is opened.
4. Enter a new name under "Name".
5. Set a tick under "Functions" for all the functions you require.
6. Confirm with a click on "OK".

## Add new page

1. In the "Navigation" area, click on the element to which want to add an operating page.
2. In the "Tiles" tab of the associated operating page, click on the plus symbol next to the page name.
  - The menu "Add new page" opens.
3. Assign a name under "Name".
4. As an option, under "Copy from", enter an operating page whose content is to be taken over at the creation of the new page.
5. Set a tick under "Functions" for all the functions you require.
6. Confirm with a click on "OK".

## Delete page

1. In the "Tiles" tab select the operating page you want to delete.
2. Click on the dustbin symbol to delete the operating page.
  - The operating page is removed.

## Set page as homepage

An operating page specified as homepage, which opens first in the IoT Dashboard for all users after the login.



### Notice

Every user later has the possibility in the IoT Dashboard to specify an own individual homepage.

1. In the "Navigation" area, click with the right mouse button on an element of the building structure whose operating page you want to set as homepage.
  - The selection menu opens.
2. Select the option "Set as homepage".
  - The "Homepage" is marked in the navigation structure with a house symbol.

## Adjust page access

The page access is adjusted as describe under see chapter 8.6 "User rights" on page 67.

## Adjusting the assignment of a page (to a room, etc.)

1. Click on the page whose assignment you want to change.
2. Pull the page to the desired position via drag and drop.



## 8.8 Configuration of the operating pages

All operating pages can be added to controls via drag and drop. For this the controls are pulled from the list in the "Paste" area into the "Tiles" area of the desired operating page.

The individual controls are represented as tiles. The size of the tiles is adjusted via the grid in the page viewer by pulling. Some controls require more space in the grid, while the maximum height and width is predetermined for each control.

The parameter window shows information about the individual controls.

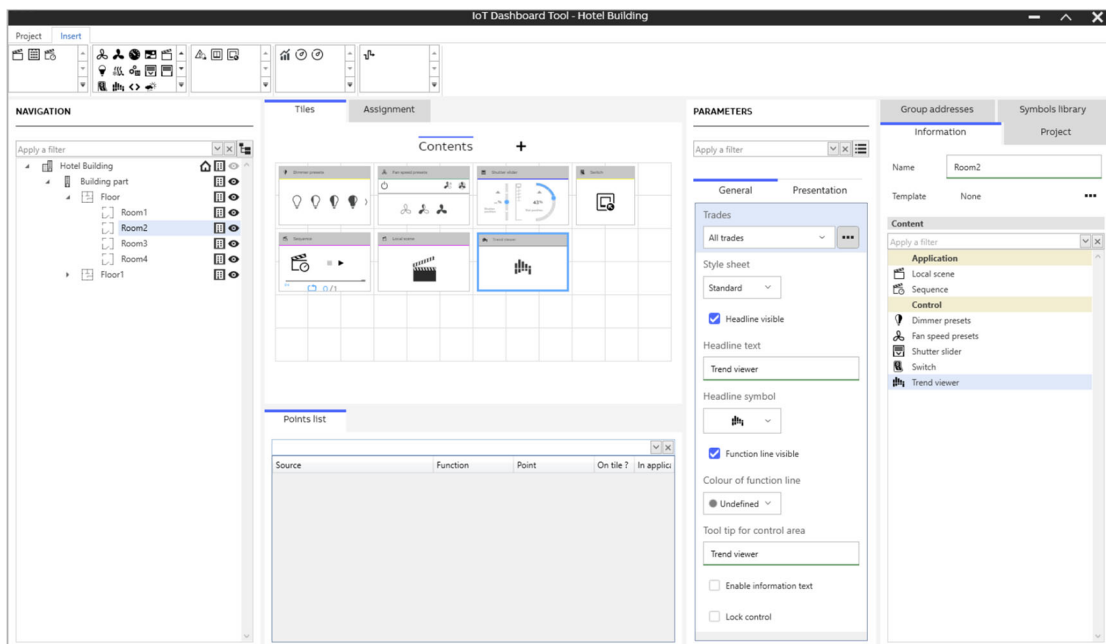

Fig. 30: Adding controls

### Adding and parameterising controls

1. In the "Navigation" area, select the operating page you want to edit.
2. Select a control in the "Paste" tab from the different categories.
3. Pull the control into the "Tiles" tab.
4. If necessary, adjust the size of the tiles by pulling on their corners.
5. Specify the parameter settings in the "Parameter" tab for the added control.



#### Notice

The individual controls and the parameters available for each control are described starting from Chapter 9.1 "General parameters" on page 91.

## 9 Controls and Parameters

After creating the navigation structure, different controls can be added to the individual operating pages. For this the available controls are pulled out of the selection window into the operating page via drag and drop.

The controls serve as control areas with which the user later operates the various functions in the web-based IoT Dashboard. They are used to fulfil the basic functions such as "Switching", "Dimming", "Blinds" and "Scenes". For their individual appearance, as well as individual operation, the controls are parameterised in the IoT Dashboard Tool. For this the different parameters are available in the selection area on the right.

The controls with the configurable parameters and communication objects are described in the following.

**Notice**

The controls can also be operated in the IoT Dashboard Tool. However, here the operation is intended for testing the functions.

**Notice**

For a major part of the controls, trends can be raised and displayed. Also alarm messages can be configured. A precise description of the procedure is available in Chapter 9.28.6 "Application "Trends"" on page 263 and Chapter 9.28.3 "Application "Alarms"" on page 252.

**9.1 General parameters**

In the IoT Dashboard Tool under "Parameters" in the "General" tab, there is a series of general parameters that are identical for the major part of the controls that can be added.

Before the individual parameters of the controls or applications are described, the general parameters should be listed at this point (tab "General" under "Parameters").



**Notice**

Please note that with the "Scheduler" application and the functions "Physical meter", "Virtual meter" in tab "General" of the applications, only the parameter "Functions" can be set.

**9.1.1 Parameters**

**9.1.1.1 Functions**

Options:	All
	System
	Electricity
	Lighting
	Blind and Shutter
	HVAC
	Temperature
	Fan
	Metering
	Security
	Emergency
	Function (New function)

This parameter can be used to specify possible functions of the control.

- All:
  - The control execute all functions.
- System:
  - The control can execute system functions.
- Electricity:
  - The control can execute electrical functions.
- Lighting:
  - The control can execute lighting functions.
- Blind and Shutter:
  - The control can execute blind and shutter functions.
- HVAC:
  - The control execute HVAC functions.
- Temperature:
  - The control can execute temperature functions.
- Fan:
  - The control can execute fan functions.

- Metering:
  - The control can execute metering functions.
- Security:
  - The control can execute security functions.
- Emergency:
  - The control can execute emergency functions.
- Function (New function):
  - The control can execute any definable function.

### 9.1.1.2 Style sheet

Options:	Default
	x

The parameter can be used to assign a predefined style sheet to the control.

- Standard:
  - The standard style sheet is selected.
- x:
  - An individually configured style sheet is selected.

### 9.1.1.3 Headline visible

Options:	deactivated
	activated

This parameter can be used to switch the headline visible or invisible.

- Disabled:
  - The headline is visible.
- Enabled:
  - The headline is invisible.

### 9.1.1.4 Headline text

Options:	<Headline-Text>
----------	-----------------

This parameter can be used to change the text in the headline of the control. The preset text can be replaced with any arbitrary text. The length of the text is limited to 30 characters.



#### Notice

The parameter is only adjustable if the "Headline visible" parameter is set to "Enabled".

## 9.1.1.5 Headline symbol

Options:	Custom (if available)
	Function
	Communication
	Energy
	Lighting
	Multi-media
	Navigation
	Notification
	Object
	Scene
	System
	Location
	Temperature
	Window and door

- Custom (if available)
- Function
- Communication
- Energy
- Lighting
- Multi-media
- Navigation
- Notification
- Object
- Scene
- System
- Location
- Temperature
- Window and door

This parameter is used to select any symbol from the various listed categories in the symbols library. The symbol is displayed in the headline of the control.



### Notice

The parameter is only adjustable if the "Headline visible" parameter is set to "Enabled".

**9.1.1.6 Function line visible**

Options:	deactivated
	activated

The function line marks the function group in colour to which the control belongs.

This parameter can be used to switch the function line visible or invisible.

- Disabled:
  - Function line is visible.
- Enabled:
  - Function line is invisible.

**9.1.1.7 Colour of function line**

Options:	Alarm
	Blind
	Fan
	Feedback
	Light
	Scene
	Temperature
	Not defined

- Alarm:
  - The function line (red) categorises the control as "Alarm" function.
- Blind:
  - The function line (blue) categorises the control as "Blind" function.
- Fan:
  - The function line (turquoise) categorises the control as "Fan" function.
- Feedback:
  - The function line (blue) categorises the control as "Feedback" function.
- Light:
  - The function line (yellow) categorises the control as "Light" function.
- Scene:
  - The function line (pink) categorises the control as "Scene" function.
- Temperature:
  - The function line (orange) categorises the control as "Temperature" function.
- Not defined:
  - The function line (grey) categorises the control as "Not defined" function.

This parameter can be used to change the colour of the function line. The colour scheme of the function line determines the category to which the control belongs.



**Notice**

The parameter is only adjustable if the "Function line visible" parameter is set to "Yes".

**9.1.1.8 Tool tip for the buttons**

Options:	<Tool tip for the buttons>
----------	----------------------------

This parameter can be used to change the text that is displayed in the tool tip of the buttons of a control. The preset tool tip can be replaced with any arbitrary text. The length of the text is limited to 100 characters.

**9.1.1.9 Enable information text**

Options:	deactivated
	activated

- Disabled:
  - Disables the information text within a control.
- Enabled:
  - Enables the information text within a control.

**9.1.1.10 Lock control**

Options:	deactivated
	activated

- Disabled:
  - The control is visible and responds to press commands or clicks.
- Enabled:
  - The control is invisible and does not respond to press commands or clicks.

The parameter is used to set whether the control is visible and whether the user can execute actions.

**9.2 Control "Local scene"**

The "Local scene" control is part of an application. Local scenes are scenes that are executed by the IoT Dashboard Server at the start of a scene. The control serves for the activation of the scene. It can be added as function (without tile) or as control via drag and drop.

A detailed description of the "Local scene" application is available in Chapter 9.28.4 "Application "Local scene"" on page 258.



**Notice**

All adjustable parameters in the "General" tab are available in Chapter 9.1 "General parameters" on page 91.

**9.2.1 Parameters**

**9.2.1.1 Repeat on error**

Options:	deactivated
	activated

When the parameter is disabled, the data point is resent in case of a transmission error.

**9.2.1.2 Delay between messages**

Options:	Setting option from 0 to 9
----------	----------------------------

The parameter is used to set the time delay with which messages are executed on the bus. The time delay can be set in steps of one millisecond.

**9.2.1.3 Title information**

Options:	<Title information>
----------	---------------------

With this parameter a custom text for the description of the information type displayed in the control can be specified. The length of the text is limited to 30 characters.



**Notice**

The parameter is only adjustable if the "Enable information text" parameter is set to "Enabled".



**9.2.1.4 Standard information text**

Options:	<Standard information text>
----------	-----------------------------

This parameter can be used to specify a custom text for the standard information text. The length of the text is limited to 30 characters.



**Notice**

The parameter is only adjustable if the "Enable information text" parameter is set to "Enabled".

**9.2.1.5 Decimal places for information value**

Options:	Setting option from 0 to 5
----------	----------------------------

This parameter can be used to set the number of decimal places that are displayed for numerical values in the information field.

The delay time can be set in steps of one millisecond (min.: 0 - max.: 5).



**Notice**

The parameter is only adjustable if the "Enable information text" parameter is set to "Enabled".

**9.2.1.6 Representation in control**

Options:	Symbols
	Symbols with text
	Text

- Symbols:
  - Functions are only presented in the form of symbols.
- Symbols with text:
  - Functions are presented in the form of symbols with text.
- Text:
  - Functions are only presented in the form of text.

The parameter is used to specify how functions are presented in the control. Also symbols, text or a mixture of symbols and text can be displayed in the control.

### **9.2.2 Data points**

#### **9.2.2.1 Scene command**

The corresponding scene is enabled on the incoming data point via the "Scene command" data point.

#### **9.2.2.2 Last executed scene**

The scene number of the last executed scene can be received via the data point.

#### **9.2.2.3 Information value**

This data point is enabled when the "Enable information text" parameter is set to "Enabled".  
A telegram with the value of the information text area of the control is received via the data point.

#### **9.2.2.4 Disable**

The operating functions of the control are disabled via the data point.

**9.3 Control "Sequence"**

A sequence of scenes can be controlled via the control "Sequence".



**Notice**

All adjustable parameters in the "General" tab are available in Chapter 9.1 "General parameters" on page 91.

**9.3.1 Parameters**

**9.3.1.1 Number of loops**

Options:	Setting option from 0 to 100
----------	------------------------------

This parameter is used to specify how often a sequence is to be played anew. Values between 0 to 100 repetitions are available. At a value of 0 the sequence is replayed endlessly.

**9.3.1.2 Title information**

Options:	<Title information>
----------	---------------------

With this parameter a custom text for the description of the information type displayed in the control can be specified. The length of the text is limited to 30 characters.

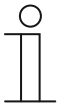

**Notice**

The parameter is only adjustable if the "Enable information text" parameter is set to "Enabled".

**9.3.1.3 Standard information text**

Options:	<Standard information text>
----------	-----------------------------

This parameter can be used to specify a custom text for the standard information text. The length of the text is limited to 30 characters.



**Notice**

The parameter is only adjustable if the "Enable information text" parameter is set to "Enabled".

## 9.3.1.4 Decimal places for information value

Options:	Setting option from 0 to 5
----------	----------------------------

This parameter can be used to set the number of decimal places that are displayed for numerical values in the information field.

The delay time can be set in steps of one millisecond (min.: 0 - max.: 5).



### Notice

The parameter is only adjustable if the "Enable information text" parameter is set to "Enabled".

## 9.3.1.5 Representation in control

Options:	Symbols
	Symbols with text
	Text

- Symbols:
  - Functions are only presented in the form of symbols.
- Symbols with text:
  - Functions are presented in the form of symbols with text.
- Text:
  - Functions are only presented in the form of text.

The parameter is used to specify how functions are presented in the control. Also symbols, text or a mixture of symbols and text can be displayed in the control.

**9.3.1.6 Symbol**

Options:	Custom (if available)
	Lighting
	Communication
	Energy
	Function
	Multi-media
	Navigation
	Notification
	Object
	Location
	Scene
	System
	Temperature
	Window and door

- Custom (if available)
- Function
- Communication
- Energy
- Lighting
- Multi-media
- Navigation
- Notification
- Object
- Scene
- System
- Location
- Temperature
- Window and door

This parameter is used to select any symbol from the various listed categories in the symbols library. The symbol determines how the button is displayed within the control.

### 9.3.2 Data points

#### 9.3.2.1 Play

A telegram is sent via the data point with which the playing of the sequence is started or continued.

#### 9.3.2.2 Stop

A telegram is sent via the data point with which the sequence is stopped.

#### 9.3.2.3 Pause

A telegram is sent via the data point with which the playing of the sequence is paused.

#### 9.3.2.4 Restart

A telegram is sent via the data point with which the playing of the sequence is restarted.

#### 9.3.2.5 Running

A status telegram is received via the data point. This indicates if the sequence is running at the current time.

#### 9.3.2.6 Paused

A status telegram is received via the data point. This indicates whether the sequence is paused at the current time.

#### 9.3.2.7 Information value

This data point is enabled when the "Enable information text" parameter is set to "Enabled".

A telegram with the value of the information text area of the control is received via the data point.

#### 9.3.2.8 Disable

The operating functions of the control are disabled via the data point.

**9.4 Control "Dimmer preset values"**

You can set up a dimmer control via the "Dimmer preset values" control. An allocated lamp can then be dimmed and switched on and off via the control.



**Notice**

All adjustable parameters in the "General" tab are available in Chapter 9.1 "General parameters" on page 91.

**9.4.1 Parameters**

**9.4.1.1 Number of presets**

Options:	Setting option from 1 to 100
----------	------------------------------

The parameter is used to set the number of predefined buttons (min.: 2 - max. 10) of the control.

**9.4.1.2 Value of preset x**

Options:	Setting option from 0 to 100 (%)
----------	----------------------------------

The parameter is used to set the stored brightness value for the individual buttons. The brightness value can be set in percentage steps (min.: 0% - max. 100%).

**9.4.1.3 Title information**

Options:	<Title information>
----------	---------------------

With this parameter a custom text for the description of the information type displayed in the control can be specified. The length of the text is limited to 30 characters.



**Notice**

The parameter is only adjustable if the "Enable information text" parameter is set to "Enabled".

**9.4.1.4 Standard information text**

Options:	<Standard information text>
----------	-----------------------------

This parameter can be used to specify a custom text for the standard information text. The length of the text is limited to 30 characters.



**Notice**

The parameter is only adjustable if the "Enable information text" parameter is set to "Enabled".

**9.4.1.5 Decimal places for information value**

Options:	Setting option from 0 to 5
----------	----------------------------

This parameter can be used to set the number of decimal places that are displayed for numerical values in the information field.

The delay time can be set in steps of one millisecond (min.: 0 - max.: 5).



**Notice**

The parameter is only adjustable if the "Enable information text" parameter is set to "Enabled".

**9.4.1.6 Representation in control**

Options:	Symbols
	Symbols with text
	Text

- Symbols:
  - Functions are only presented in the form of symbols.
- Symbols with text:
  - Functions are presented in the form of symbols with text.
- Text:
  - Functions are only presented in the form of text.

The parameter is used to specify how functions are presented in the control. Also symbols, text or a mixture of symbols and text can be displayed in the control.

**9.4.1.7 Symbol preset mode**

Options:	Automatic
	Manual

- Automatic:
  - The selection of the symbol displayed in the control happens automatically. The automatic assigning is possible only with special symbols.
- Manual:
  - The selection of the symbol displayed in the control is made manually. The manual assigning is possible with all types of symbols.

The parameter is used to set whether the symbol displayed in the control is assigned automatically or manually.



**9.4.1.8 Symbol**

Options:	Custom (if available)
	Lighting
	Communication
	Energy
	Function
	Multi-media
	Navigation
	Notification
	Object
	Location
	Scene
	System
	Temperature
	Window and door

- Custom (if available)
- Function
- Communication
- Energy
- Lighting
- Multi-media
- Navigation
- Notification
- Object
- Scene
- System
- Location
- Temperature
- Window and door

This parameter is used to select any symbol from the various listed categories in the symbols library. The symbol determines how the button is displayed within the control.



**Notice**

If parameter "Symbol preset mode" is set on "Automatic", the symbol is assigned automatically.

**9.4.1.9 Text for preset x**

Options:	Custom (if available)
	Lighting
	Communication
	Energy
	Function
	Multi-media
	Navigation
	Notification
	Object
	Location
	Scene
	System
	Temperature
	Window and door

- Custom (if available)
- Function
- Communication
- Energy
- Lighting
- Multi-media
- Navigation
- Notification
- Object
- Scene
- System
- Location
- Temperature
- Window and door

This parameter is used to select any symbol from the various listed categories in the symbols library. The symbol determines how the button is displayed within the control.



**Notice**

If parameter "Symbol preset mode" is set on "Manual", the symbol is assigned manually.

### 9.4.2 Data points

#### 9.4.2.1 Brightness command

The absolute brightness value is sent via the data point.

#### 9.4.2.2 Brightness status

The actuator sends the current brightness value via the data point.

#### 9.4.2.3 Information value

This data point is enabled when the "Enable information text" parameter is set to "Enabled".

A telegram with the value of the information text area of the control is received via the data point.

#### 9.4.2.4 Disable

The operating functions of the control are disabled via the data point.

**9.5 Control element: "Dimmer slider"**

A dimmer control can be set up via the "Dimmer slider" control. This can then be used to both dim and switch an allocated lamp on and off.

In contrast to the "Dimmer" control, here a slider is used instead of buttons.



**Notice**

All adjustable parameters in the "General" tab are available in Chapter 9.1 "General parameters" on page 91.

**9.5.1 Parameters**

**9.5.1.1 Minimum value**

Options:	Setting option from 0 to 100 (%)
----------	----------------------------------

The parameter is used to set the smallest adjustable brightness value.  
The brightness value can be set in percentage steps (min.: 0% - max. 100%).

**9.5.1.2 Maximum value**

Options:	Setting option from 0 to 100 (%)
----------	----------------------------------

The parameter is used to set the largest adjustable brightness value.  
The brightness value can be set in percentage steps (min.: 0% - max. 100%).

**9.5.1.3 Step size**

Options:	Setting option from 0 to 100 (%)
----------	----------------------------------

The parameter is used to set the smallest possible step size with which the control can be set.  
The step size can be set in percentage steps (min.: 0% - max. 100%).

**9.5.1.4 Title information**

Options:	<Title information>
----------	---------------------

With this parameter a custom text for the description of the information type displayed in the control can be specified. The length of the text is limited to 30 characters.



**Notice**

The parameter is only adjustable if the "Enable information text" parameter is set to "Enabled".

## 9.5.1.5 Standard information text

Options:	<Standard information text>
----------	-----------------------------

This parameter can be used to specify a custom text for the standard information text. The length of the text is limited to 30 characters.



### **Notice**

The parameter is only adjustable if the "Enable information text" parameter is set to "Enabled".

**9.5.1.6 Decimal places for information value**

Options:	Setting option from 0 to 5
----------	----------------------------

This parameter can be used to set the number of decimal places that are displayed for numerical values in the information field.

The delay time can be set in steps of one millisecond (min.: 0 - max.: 5).



**Notice**

The parameter is only adjustable if the "Enable information text" parameter is set to "Enabled".

**9.5.1.7 Representation in control**

Options:	Symbols
	Symbols with text
	Text

- Symbols:
  - Functions are only presented in the form of symbols.
- Symbols with text:
  - Functions are presented in the form of symbols with text.
- Text:
  - Functions are only presented in the form of text.

The parameter is used to specify how functions are presented in the control. Also symbols, text or a mixture of symbols and text can be displayed in the control.

**9.5.1.8 Symbol**

Options:	Custom (if available)
	Lighting
	Communication
	Energy
	Function
	Multi-media
	Navigation
	Notification
	Object
	Location
	Scene
	System
	Temperature
	Window and door

- Custom (if available)
- Function
- Communication
- Energy
- Lighting
- Multi-media
- Navigation
- Notification
- Object
- Scene
- System
- Location
- Temperature
- Window and door

This parameter is used to select any symbol from the various listed categories in the symbols library. The symbol determines how the button is displayed within the control.

**9.5.1.9 Display minimum/maximum value**

Options:	deactivated
	activated

The parameter is used to set whether the minimum or maximum dimming value is displayed on the slider.

## 9.5.2 Data points

### 9.5.2.1 Switch command

The 1-bit data point is used to send On and Off telegrams.

Telegram value:	0 = OFF The switch is on position OFF.
	1 = ON The switch is on position ON

### 9.5.2.2 Switching status

A status telegram is received via the data point.

Telegram value:	0 = OFF The switch is on position OFF.
	1 = ON The switch is on position ON

### 9.5.2.3 Brightness command

The absolute brightness value is sent via the data point.

### 9.5.2.4 Brightness status

The actuator sends the current brightness value via the data point.

### 9.5.2.5 Information value

This data point is enabled when the "Enable information text" parameter is set to "Enabled".

A telegram with the value of the information text area of the control is received via the data point.

### 9.5.2.6 Disable

The operating functions of the control are disabled via the data point.



**9.6 Control "Stepwise dimmer"**

A dimmer control can be set up via the "Dimmer stepwise" control. This can then be used to both dim an allocated lamp stepwise and switch it on and off.



**Notice**

All adjustable parameters in the "General" tab are available in Chapter 9.1 "General parameters" on page 91.

**9.6.1 Parameters**

**9.6.1.1 Type of dimmer**

Options:	Start/stop
	Stepwise
	Value

- Stepwise
  - Dimming up and down happens stepwise on the basis of the specified step size.
- Start/stop
  - The dimming process starts when the start symbol is activated. If the stop symbol is activated, the dimming process is stopped at the current brightness value.
- Value
  - At the start it is dimmed to a specified value or at stop to a specified value.

The parameter is used to set type of dimming process

**9.6.1.2 Step size**

Options:	1.6 %
	3.2 %
	6.25 %
	12.5 %
	25 %
	50 %

The parameter is used to specify the step size with which the dimming value is increased or reduced.

The dimming value can be set in percentage steps (min.: 1.6% - max. 50%).



**Notice**

The parameter can only be set when the "Stepwise" option is set under "Type of dimmer".

## 9.6.1.3 Activate long press

Options:	deactivated
	activated

- Disabled:
  - The settings for the behaviour at a long press of the button are disabled.
- Enabled:
  - The settings for the behaviour at a long press of the button are enabled.

The parameter is used to enable or disable the behaviour for a long press of the button.



### Notice

The parameter can only be set when the "Stepwise" option is set under "Type of dimmer".

## 9.6.1.4 Actuation at a long press of the button after...

Options:	0.3 seconds
	0.4 seconds
	0.5 seconds
	0.6 seconds
	0.7 seconds

The parameter is used to set the time after which a long button press is registered.

The time can be set in steps of 0.3 to 0.7 seconds.



### Notice

The parameter can only be set when the "Stepwise" option is set under "Type of dimmer".

## 9.6.1.5 Title information

Options:	<Title information>
----------	---------------------

With this parameter a custom text for the description of the information type displayed in the control can be specified. The length of the text is limited to 30 characters.



### Notice

The parameter is only adjustable if the "Enable information text" parameter is set to "Enabled".

**9.6.1.6 Standard information text**

Options:	<Standard information text>
----------	-----------------------------

This parameter can be used to specify a custom text for the standard information text. The length of the text is limited to 30 characters.



**Notice**  
The parameter is only adjustable if the "Enable information text" parameter is set to "Enabled".

**9.6.1.7 Decimal places for information value**

Options:	Setting option from 0 to 5
----------	----------------------------

This parameter can be used to set the number of decimal places that are displayed for numerical values in the information field.

The delay time can be set in steps of one millisecond (min.: 0 - max.: 5).



**Notice**  
The parameter is only adjustable if the "Enable information text" parameter is set to "Enabled".

**9.6.1.8 Representation in control**

Options:	Symbols
	Symbols with text
	Text

- Symbols:
  - Functions are only presented in the form of symbols.
- Symbols with text:
  - Functions are presented in the form of symbols with text.
- Text:
  - Functions are only presented in the form of text.

The parameter is used to specify how functions are presented in the control. Also symbols, text or a mixture of symbols and text can be displayed in the control.

**9.6.1.9 Symbol for increase**

Options:	Custom (if available)
	Lighting
	Communication
	Energy
	Function
	Multi-media
	Navigation
	Notification
	Object
	Location
	Scene
	System
	Temperature
	Window and door

- Custom (if available)
- Function
- Communication
- Energy
- Lighting
- Multi-media
- Navigation
- Notification
- Object
- Scene
- System

- Location
- Temperature
- Window and door

This parameter is used to select any symbol from the various listed categories in the symbols library. The symbol determines the look of the button within the control with which the brightness value is increased.

**9.6.1.10 Symbol for decrease**

Options:	Custom (if available)
	Lighting
	Communication
	Energy
	Function
	Multi-media
	Navigation
	Notification
	Object
	Location
	Scene
	System
	Temperature
	Window and door

- Custom (if available)
- Function
- Communication
- Energy
- Lighting
- Multi-media
- Navigation
- Notification
- Object
- Scene
- System
- Location
- Temperature
- Window and door

This parameter is used to select any symbol from the various listed categories in the symbols library. The symbol determines the look of the button within the control with which the brightness value is reduced.

**9.6.1.11 Symbol**

Options:	Custom (if available)
	Lighting
	Communication
	Energy
	Function
	Multi-media
	Navigation
	Notification
	Object
	Location
	Scene
	System
	Temperature
	Window and door

- Custom (if available)
- Function
- Communication
- Energy
- Lighting
- Multi-media
- Navigation
- Notification
- Object
- Scene
- System
- Location
- Temperature
- Window and door

This parameter is used to select any symbol from the various listed categories in the symbols library. The symbol determines how the button is displayed within the control.

## 9.6.1.12 Button position

Options:	Increase = left / Decrease = right
	Increase = right / Decrease = left

- Increase = left / Decrease = right
  - In the control the button for increasing the brightness value is displayed on the left and the button for decreasing the brightness value on the right.
- Increase = right / Decrease = left
  - In the control the button for increasing the brightness value is displayed on the right and the button for decreasing the brightness value on the left.

The parameter is used to set where the buttons for increasing and reducing the brightness value are positioned.



**9.6.2 Data points**

**9.6.2.1 Switch command**

The 1-bit data point is used to send On and Off telegrams.

Telegram value:	0 = OFF The switch is on position OFF.
	1 = ON The switch is on position ON

**9.6.2.2 Switching status**

A status telegram is received via the data point.

Telegram value:	0 = OFF The switch is on position OFF.
	1 = ON The switch is on position ON

**9.6.2.3 Start/Stop command**

The data point is only available when parameter "Type of dimmer" is set on "Start/stop".

The parameter is used to send a telegram with which the dimming process can be started or stopped.

**9.6.2.4 Command: Relative dimming**

The data point is enabled when parameter "Type of dimmer" is set on "Stepwise".

The data point is used to send a telegram with which the relative dimming value is polled.

**9.6.2.5 Brightness command**

The communication object is enabled when parameter "Type of dimmer" is set on "Value".

The parameter is used to send a command telegram with the absolute brightness value.

**9.6.2.6 Brightness status**

The actuator sends a status telegram with the absolute brightness value via the data point.

**9.6.2.7 Information value**

The data point is only adjustable if the "Enable information text" parameter is set to "Enabled"

The data point is used to send the stored text for the information area of the control.

**9.6.2.8 Disable**

The operating functions of the control are disabled via the data point.

**9.7 Control "Fan speed preset values"**

The control "Fan speed preset values" can be used to set up a fan control. Here, for example, the fan speed level for an allocated fan can be changed



**Notice**

All adjustable parameters in the "General" tab are available in Chapter 9.1 "General parameters" on page 91.

**9.7.1 Parameters**

**9.7.1.1 Number of stages**

Options:	Setting option from 2 to 9
----------	----------------------------

The parameter is used to set the number of fan speed levels (min.: 2 - max.: 9) of the control.

**9.7.1.2 Automatic mode visible**

Options:	deactivated
	activated

- Disabled:
  - The button for enabling the automatic mode is not available.
- Enabled:
  - The button for enabling the automatic mode is available.

The parameter can be used to set whether the button for enabling the automatic mode is to be available.

**9.7.1.3 Start Delay**

Options:	Setting option from 0.00:00:00 to 12:59:59 (hh:mm:ss)
----------	---

The parameter is used to set the time for a start delay of the fan.

**9.7.1.4 Overrun Delay**

Options:	Setting option from 0.00:00:00 to 12:59:59 (hh:mm:ss)
----------	---

The parameter is used to set the time for an overrun delay of the fan.

**9.7.1.5 Boost switch visible**

Options:	deactivated
	activated

- Disabled:
  - The button for enabling the boost mode is not displayed.
- Enabled:
  - The button for enabling the boost mode is displayed.

The parameter can be used to set whether the button for enabling the boost mode is to be displayed in the control.

**9.7.1.6 Boost stage**

Options:	Speed x
----------	---------

The parameter is used to set the fan speed level in boost mode. The number of the available fan speed levels depends on the number of levels set beforehand under "Number of stages" (see chapter 9.7.1.1 "Number of stages" on page 122).



**Notice**  
The parameter is only adjustable if the "Boost switch visible" parameter is set to "Enabled".

**9.7.1.7 Timeout for boost**

Options:	Setting option from 00:01:00 to 12:59:59 (hh:mm:ss)
----------	---

The parameter is used to set the duration of the boost mode.



**Notice**  
The parameter is only adjustable if the "Boost switch visible" parameter is set to "Enabled".

**9.7.1.8 ON/OFF behaviour**

Options:	On/Off using separate points
	On/Off linked to first stage
	No On/Off

- ON/OFF using separate points
  - The fan is switched directly on or off.
- On/Off linked to first stage
  - The fan can only be switched on and off via the first fan stage.
- No ON/OFF
  - The fan is not switched on or off manually. It is switched on and off automatically.

The parameter is used to specify how or via which fan stage the fan can be switched on and off.

**9.7.1.9 Title information**

Options:	<Title information>
----------	---------------------

With this parameter a custom text for the description of the information type displayed in the control can be specified. The length of the text is limited to 30 characters.



**Notice**

The parameter is only adjustable if the "Enable information text" parameter is set to "Enabled".

**9.7.1.10 Standard information text**

Options:	<Standard information text>
----------	-----------------------------

This parameter can be used to specify a custom text for the standard information text. The length of the text is limited to 30 characters.



**Notice**

The parameter is only adjustable if the "Enable information text" parameter is set to "Enabled".

**9.7.1.11 Decimal places for information value**

Options:	Setting option from 0 to 5
----------	----------------------------

This parameter can be used to set the number of decimal places that are displayed for numerical values in the information field.

The delay time can be set in steps of one millisecond (min.: 0 - max.: 5).



**Notice**

The parameter is only adjustable if the "Enable information text" parameter is set to "Enabled".

**9.7.1.12 Representation in control**

Options:	Symbols
	Symbols with text
	Text

- Symbols:
  - Functions are only presented in the form of symbols.
- Symbols with text:
  - Functions are presented in the form of symbols with text.
- Text:
  - Functions are only presented in the form of text.

The parameter is used to specify how functions are presented in the control. Also symbols, text or a mixture of symbols and text can be displayed in the control.

**9.7.1.13 Symbol preset mode**

Options:	Automatic
	Manual

- Automatic:
  - The selection of the symbol displayed in the control happens automatically. The automatic assigning is possible only with special symbols.
- Manual:
  - The selection of the symbol displayed in the control is made manually. The manual assigning is possible with all types of symbols.

The parameter is used to set whether the symbol displayed in the control is assigned automatically or manually.

## 9.7.1.14 Symbol

Options:	Custom (if available)
	Lighting
	Communication
	Energy
	Function
	Multi-media
	Navigation
	Notification
	Object
	Location
	Scene
	System
	Temperature
	Window and door

- Custom (if available)
- Function
- Communication
- Energy
- Lighting
- Multi-media
- Navigation
- Notification
- Object
- Scene
- System
- Location
- Temperature
- Window and door

This parameter is used to select any symbol from the various listed categories in the symbols library. The symbol determines how the button is displayed within the control.



### Notice

If parameter "Symbol preset mode" is set on "Automatic", the symbol is assigned automatically.

## 9.7.1.15 Text for preset x

Options:	Custom (if available)
	Lighting
	Communication
	Energy
	Function
	Multi-media
	Navigation
	Notification
	Object
	Location
	Scene
	System
	Temperature
	Window and door

- Custom (if available)
- Function
- Communication
- Energy
- Lighting
- Multi-media
- Navigation
- Notification
- Object
- Scene
- System
- Location
- Temperature
- Window and door

This parameter is used to select any symbol from the various listed categories in the symbols library. The symbol determines how the button is displayed within the control.



### Notice

If parameter "Symbol preset mode" is set on "Manual", the symbol is assigned manually.

## 9.7.1.16 Text for stage x

Options:	<Text for stage x>
----------	--------------------

The parameter is used to specify the text that is displayed for fan speed x.



### **Notice**

The parameter is only adjustable if the "Representation in control" parameter is set on "Text" or "Symbols with text".



### 9.7.2 Data points

#### 9.7.2.1 Fan speed command

This data point is used to enable any fan speed.

#### 9.7.2.2 Status Fan speed

This data point is used to receive a telegram with the status of the fan speed.

#### 9.7.2.3 ON/OFF Command

The data point is enabled when parameter "ON/OFF behaviour" linked with "ON/OFF" was parameterised via separate points.

A command telegram is sent via the data point with which the fan is switched on and off.

#### 9.7.2.4 ON/OFF Status

The data point is only available when parameter "ON/OFF behaviour" is set on "ON/OFF" via separate points.

A status telegram is received via the data point.

#### 9.7.2.5 Automatic command

The data point is enabled when parameter "Automatic mode visible" is set on "Enabled".

Automatic mode can be "Enabled" or "Disabled" via the data point.

#### 9.7.2.6 Status Automatic

The data point is enabled when parameter "Automatic mode visible" is set on "Enabled".

A status telegram is received via the data point, which supplies information about the automatic mode.

#### 9.7.2.7 Boost command

The data point is enabled when parameter "Boost switch visible" is set on "Enabled".

The data point is used to send a command telegram with which the boost mode is started.

#### 9.7.2.8 Information value

This data point is enabled when the "Enable information text" parameter is set to "Enabled".

A telegram with the value of the information text area of the control is received via the data point.

#### 9.7.2.9 Disable

The operating functions of the control are disabled via the data point.

**9.8 Control "Fan speed slider"**

A fan control can be set up via the "Fan slider" control. This, for example, allows the fan speed level to be changed for an allocated fan.

If a control is added to an operating page, the dimensional unit in which the values are to be measured must be specified first (see chapter 9.8.1.1 "Unit" on page 130).



**Notice**

All adjustable parameters in the "General" tab are available in Chapter 9.1 "General parameters" on page 91.

**9.8.1 Parameters**

**9.8.1.1 Unit**

Options:	Data volume
	Acceleration
	Amount of substance
	Angle
	Rotational acceleration
	Range
	Capacities
	Charge density of surface
	Charge volume of surface
	Compressibility
	Durability
	Electric charge
	Electric current density
	Electric dipole moment
	Electric field strength
	Electric power consumption
	Electrical conductivity
	Electric current
	Electric potential
	Electric resistance
	Specific electric resistance
	Energy
	Energy per volume of material category
	Flow rate
	Strength
	Frequency
	Heating capacity
	Illuminance
	Inductance
	Irradiance
Kelvin per percent	
KNX meter	
Length	

Brightness
Luminous flux
Light intensity
Magnetic field strength
Magnetic flux
Magnetic moment
Magnetic flux density
Mass
Mass flow
Momentum
Force
Force factor
Pressure
Ratio
Rotational speed
Solid angle
Specific weight
Speed
Surface compound
Temperature
Temperature change rate
Thermal conductivity
Thermoelectric force
Torque
Volume

This parameter is used to set the dimensional unit in which the values are measured in the control. Different dimensional units are allocated to the categories listed above.



**Notice**

When the control is added to the operating page, the dimensional unit must be specified.

**9.8.1.2 Automatic mode visible**

Options:	deactivated
	activated

- Disabled:
  - The button for enabling the automatic mode is not available.
- Enabled:
  - The button for enabling the automatic mode is available.

The parameter can be used to set whether the button for enabling the automatic mode is to be available.

## 9.8.1.3 Start Delay

Options:	Setting option from 0.00:00:00 to 12:59:59 (hh:mm:ss)
----------	---

The parameter is used to set the time for a start delay of the fan.

## 9.8.1.4 Overrun Delay

Options:	Setting option from 0.00:00:00 to 12:59:59 (hh:mm:ss)
----------	---

The parameter is used to set the time for an overrun delay of the fan.

## 9.8.1.5 Boost switch visible

Options:	deactivated
	activated

- Disabled:
  - The button for enabling the boost mode is not displayed.
- Enabled:
  - The button for enabling the boost mode is displayed.

The parameter can be used to set whether the button for enabling the boost mode is to be displayed in the control.

## 9.8.1.6 Boost value

Options:	Setting option from 1 to 100 (%)
----------	----------------------------------

The parameter is used to set the percentage fan speed level in boost mode.



### Notice

The parameter is only adjustable if the "Boost switch visible" parameter is set to "Enabled".

## 9.8.1.7 Timeout for boost

Options:	Setting option from 00:01:00 to 12:59:59 (hh:mm:ss)
----------	---

The parameter is used to set the duration of the boost mode.



### Notice

The parameter is only adjustable if the "Boost switch visible" parameter is set to "Enabled".

## 9.8.1.8 Show status value

Options:	deactivated
	activated

- Disabled:
  - The current status value is not displayed.
- Enabled:
  - The current status value is displayed.

This parameter is used to set whether the current status value is to be displayed.

## 9.8.1.9 Step size

Options:	Setting option from 1 to 100
----------	------------------------------

The parameter is used to set the smallest possible step size with which the control can be set. The step size can be set in percentage steps (min.: 0% - max. 100%).

## 9.8.1.10 Minimum value

Options:	Setting option from 0 to 100 (%)
----------	----------------------------------

The parameter is used to set the smallest adjustable brightness value. The brightness value can be set in percentage steps (min.: 0% - max. 100%).

## 9.8.1.11 Maximum value

Options:	Setting option from 0 to 100 (%)
----------	----------------------------------

The parameter is used to set the largest adjustable brightness value. The brightness value can be set in percentage steps (min.: 0% - max. 100%).

**9.8.1.12 ON/OFF behaviour**

Options:	On/Off using separate points
	On/Off linked to first stage
	No On/Off

- ON/OFF using separate points
  - The fan is switched directly on or off.
- On/Off linked to first stage
  - The fan can only be switched on and off via the first fan stage.
- No ON/OFF
  - The fan is not switched on or off manually. It is switched on and off automatically.

The parameter is used to specify how or via which fan stage the fan can be switched on and off.

**9.8.1.13 Title information**

Options:	<Title information>
----------	---------------------

With this parameter a custom text for the description of the information type displayed in the control can be specified. The length of the text is limited to 30 characters.



**Notice**

The parameter is only adjustable if the "Enable information text" parameter is set to "Enabled".

**9.8.1.14 Standard information text**

Options:	<Standard information text>
----------	-----------------------------

This parameter can be used to specify a custom text for the standard information text. The length of the text is limited to 30 characters.



**Notice**

The parameter is only adjustable if the "Enable information text" parameter is set to "Enabled".

**9.8.1.15            Decimal places for information value**

---

Options:	Setting option from 0 to 5
----------	----------------------------

---

This parameter can be used to set the number of decimal places that are displayed for numerical values in the information field.

The delay time can be set in steps of one millisecond (min.: 0 - max.: 5).



**Notice**  
The parameter is only adjustable if the "Enable information text" parameter is set to "Enabled".

### 9.8.2 Data points

#### 9.8.2.1 Fan speed command

This data point is used to enable any fan speed.

#### 9.8.2.2 Status Fan speed

This data point is used to receive a telegram with the status of the fan speed.

#### 9.8.2.3 ON/OFF Command

The data point is enabled when parameter "ON/OFF behaviour" linked with "ON/OFF" was parameterised via separate points.

A command telegram is sent via the data point with which the fan is switched on and off.

#### 9.8.2.4 ON/OFF Status

The data point is only available when parameter "ON/OFF behaviour" is set on "ON/OFF" via separate points.

A status telegram is received via the data point.

#### 9.8.2.5 Automatic command

The data point is enabled when parameter "Automatic mode visible" is set on "Enabled".

Automatic mode can be "Enabled" or "Disabled" via the data point.

#### 9.8.2.6 Status Automatic

The data point is enabled when parameter "Automatic mode visible" is set on "Enabled".

A status telegram is received via the data point, which supplies information about the automatic mode.

#### 9.8.2.7 Boost command

The data point is enabled when parameter "Boost switch visible" is set on "Enabled".

The data point is used to send a command telegram with which the boost mode is started.

#### 9.8.2.8 Information value

This data point is enabled when the "Enable information text" parameter is set to "Enabled".

A telegram with the value of the information text area of the control is received via the data point.

#### 9.8.2.9 Disable

The operating functions of the control are disabled via the data point.



**9.9 Control "Gauge"**

Information in a previously specified dimensional unit can be displayed via the control "Gauge".



**Notice**

When the control is added to an operating page, a dimensional unit must be specified. This dimensional unit cannot be changed later (see chapter 9.9.1.1 "Unit" on page 137).

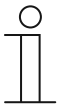

**Notice**

All adjustable parameters in the "General" tab are available in Chapter 9.1 "General parameters" on page 91.

**9.9.1 Parameters**

**9.9.1.1 Unit**

Options:	Unit
	Data volume
	Electric admittance
	Illuminance
	Range
	Acceleration
	Irradiance
	Duration
	Torque
	Rotational speed
	Pressure
	Electric field strength
	Electric charge
	Electrical conductivity
	Electric current density
	Electric current
	Electric resistance
	Electric dipole moment
	Electric potential
	Energy
	Energy per material volume category
	Flow
	Frequency
	Speed
	Inductance
	Capacities
	Kelvin per percent
	KNX meter
	Force
	Charge density surface
	Charge density volume
	Length
	Power

Power factor
Luminance
Luminous intensity
Luminous flux
Magnetic field strength
Magnetic flux density
Magnetic flux
Magnetic moment
Mass
Mass flow
Momentum
Surface tension
Solid angle
Specific weight
Amount of substance
Temperature
Temperature change rate
Thermoelectric power
Ratio
Volume
Heat capacity
Thermal conductivity
Angle
Angular acceleration

This parameter is used to set the dimensional unit in which the values are measured in the control. Different dimensional units are allocated to the categories listed above.



**Notice**

When the control is added to the operating page, the dimensional unit must be specified.

**9.9.1.2 Minimum value**

Options:	Setting option from 0 to 100 (%)
----------	----------------------------------

The parameter is used to set the smallest adjustable brightness value.  
The brightness value can be set in percentage steps (min.: 0% - max. 100%).

**9.9.1.3 Maximum value**

Options:	Setting option from 0 to 100 (%)
----------	----------------------------------

The parameter is used to set the largest adjustable brightness value.  
The brightness value can be set in percentage steps (min.: 0% - max. 100%).

**9.9.1.4 Number of decimals**

Options:	Setting option from 0 to 3
----------	----------------------------

The parameter is used to specify the number of decimal places the presented values should have.

The number can be set in steps from one decimal place (min.: 0 - max.: 3).

**9.9.1.5 Title information**

Options:	<Title information>
----------	---------------------

With this parameter a custom text for the description of the information type displayed in the control can be specified. The length of the text is limited to 30 characters.



**Notice**

The parameter is only adjustable if the "Enable information text" parameter is set to "Enabled".

**9.9.1.6 Standard information text**

Options:	<Standard information text>
----------	-----------------------------

This parameter can be used to specify a custom text for the standard information text. The length of the text is limited to 30 characters.



**Notice**

The parameter is only adjustable if the "Enable information text" parameter is set to "Enabled".

**9.9.1.7 Decimal places for information value**

Options:	Setting option from 0 to 5
----------	----------------------------

This parameter can be used to set the number of decimal places that are displayed for numerical values in the information field.

The delay time can be set in steps of one millisecond (min.: 0 - max.: 5).



**Notice**

The parameter is only adjustable if the "Enable information text" parameter is set to "Enabled".

**9.9.1.8 Default representation**

Options:	Analogue gauge
	Bar graph
	Digital gauge

- Analogue gauge:
  - Values are displayed in the control in an analogue gauge.
- Bar-graph:
  - Values are displayed in the control in a bar-graph.
- Digital gauge:
  - Values are displayed in the control in a digital gauge.

The parameter is used to set how values are displayed in the control.



**Notice**

The dimensional unit corresponds to the settings that were made at the start for the "Unit" parameter. A later change of the dimensional unit is not possible.

**9.9.1.9 Number of colour ranges**

Options:	Setting option from 1 to 3
----------	----------------------------

This parameter is used to specify the number of the different colour ranges available within the control.

The value can be set in decimal steps of 1 (min.: 1 - max.: 3).

**9.9.1.10 Start of colour range x**

Options:	Setting option from 0 to 100 (%)
----------	----------------------------------

The parameter is used to set the value from which the colour range starts.

The value can be set in percentage steps (min.: 0 - max. 100).



**Notice**

The parameter is only adjustable if the "Number of colour ranges" parameter is set to a value higher than 1.

**9.9.1.11 Colour of range x**

Options:	<Colour of range x>
----------	---------------------

This parameter is used to specify the colours of the different colour ranges. Any colours can be selected from the colour models RGB, CMYK, HLS and HSB.



**Notice**

The parameter is only adjustable if the "Number of colour ranges" parameter is set to a value higher than 1.

**9.9.1.12 Main divisions**

Options:	Setting option from 1 to 100
----------	------------------------------

The parameter is used to specify the number of main divisions of the analogue gauge or bar graph.

There must be at least one main division available. A value of 10 main divisions represents the maximum.

**9.9.1.13 Subdivisions**

Options:	Setting option from 1 to 100
----------	------------------------------

The parameter is used to specify the number of the subdivisions of each main division of the analogue gauge or bar graph.

There must be at least one subdivision available. A value of 10 main divisions represents the maximum.

**9.9.1.14 Show labels**

Options:	All
	Min/Max only
	No

- All:
  - All values of the main divisions are displayed in the analogue gauge or bar graph of the control.
- Min/Max only:
  - Only the minimum and maximum values are displayed in the analogue gauge or bar graph of the control.
- No:
  - No values are displayed in the analogue gauge or bar graph of the control.

The parameter is used to set how values are displayed in the analogue gauge or bar graph.

## 9.9.1.15 Number of label decimals

Options:	Setting option from 0 to 3
----------	----------------------------

The parameter is used to specify the number of decimal places for the representation of the gauge labels in the control.

The value can be set in decimal steps of 1 (min.: 0 - max.: 3).



### Notice

The parameter is only adjustable if the "Show labels" parameter is set on "All" or "Min/Max only".

## 9.9.1.16 Display numerical value

Options:	deactivated
	activated

- Disabled:
  - The value received last is not displayed next to the analogue gauge.
- Enabled:
  - The value received last is displayed next to the analogue gauge.

The parameter is used to set whether the value received last is displayed next to the analogue gauge in the control.

### **9.9.2 Data points**

#### **9.9.2.1 Information value**

The data point is only adjustable if the "Enable information text" parameter is set to "Enabled"

The data point is used to send the stored text for the information area of the control.

#### **9.9.2.2 Status value**

A telegram with the status value is received via the data point.

**9.10 Control "Remote Scene"**

A scene can be allocated via the "Remote scene" control. A remote scene is a scene that is executed by a remote device and not via the IoT Dashboard Server.

The scene starts with a click on the scene button in the control, if this has been so defined. The scene must first be created by the installer.



**Notice**

All adjustable parameters in the "General" tab are available in Chapter 9.1 "General parameters" on page 91.

**9.10.1 Parameters**

**9.10.1.1 Title information**

Options:	<Title information>
----------	---------------------

With this parameter a custom text for the description of the information type displayed in the control can be specified. The length of the text is limited to 30 characters.



**Notice**

The parameter is only adjustable if the "Enable information text" parameter is set to "Enabled".

**9.10.1.2 Standard information text**

Options:	<Standard information text>
----------	-----------------------------

This parameter can be used to specify a custom text for the standard information text. The length of the text is limited to 30 characters.



**Notice**

The parameter is only adjustable if the "Enable information text" parameter is set to "Enabled".

**9.10.1.3 Decimal places for information value**

Options:	Setting option from 0 to 5
----------	----------------------------

This parameter can be used to set the number of decimal places that are displayed for numerical values in the information field.

The delay time can be set in steps of one millisecond (min.: 0 - max.: 5).



**Notice**

The parameter is only adjustable if the "Enable information text" parameter is set to "Enabled".



**9.10.1.4 Representation in control**

Options:	Symbols
	Symbols with text
	Text

- Symbols:
  - Functions are only presented in the form of symbols.
- Symbols with text:
  - Functions are presented in the form of symbols with text.
- Text:
  - Functions are only presented in the form of text.

The parameter is used to specify how functions are presented in the control. Also symbols, text or a mixture of symbols and text can be displayed in the control.

### 9.10.2 Data points

#### 9.10.2.1 Scene command

The corresponding scene is enabled on the incoming data point via the "Scene command" data point.

#### 9.10.2.2 Information value

This data point is enabled when the "Enable information text" parameter is set to "Enabled".

A telegram with the value of the information text area of the control is received via the data point.

#### 9.10.2.3 Disable

The operating functions of the control are disabled via the data point.

**9.11 Control "Scheduler viewer"**

The times of the events triggered last and to be triggered next are displayed in the "Scheduler viewer" control. The control can be used as overview of the activities of an entire day.



**Notice**

All adjustable parameters in the "General" tab are available in Chapter 9.1 "General parameters" on page 91.

**9.11.1 Parameters**

**9.11.1.1 Title information**

Options:	<Title information>
----------	---------------------

With this parameter a custom text for the description of the information type displayed in the control can be specified. The length of the text is limited to 30 characters.



**Notice**

The parameter is only adjustable if the "Enable information text" parameter is set to "Enabled".

**9.11.1.2 Standard information text**

Options:	<Standard information text>
----------	-----------------------------

This parameter can be used to specify a custom text for the standard information text. The length of the text is limited to 30 characters.



**Notice**

The parameter is only adjustable if the "Enable information text" parameter is set to "Enabled".

**9.11.1.3 Decimal places for information value**

Options:	Setting option from 0 to 5
----------	----------------------------

This parameter can be used to set the number of decimal places that are displayed for numerical values in the information field.

The delay time can be set in steps of one millisecond (min.: 0 - max.: 5).



**Notice**

The parameter is only adjustable if the "Enable information text" parameter is set to "Enabled".

## 9.11.1.4 Show last event

Options:	deactivated
	activated

- Disabled:
  - No information about the event executed last is displayed.
- Enabled:
  - Information about the event executed last is displayed.

The parameter is used to set whether information about the event executed last is to be displayed in the control.

## 9.11.1.5 Show next event

Options:	deactivated
	activated

- Disabled:
  - No information about the next event is displayed.
- Enabled:
  - Information about the next event is displayed.

The parameter is used to set whether information about the next event is to be displayed in the control.

## 9.11.1.6 Show overwrite status

Options:	deactivated
	activated

- Disabled:
  - When the scheduler is overwritten, this information is not displayed in the control.
- Enabled:
  - When the scheduler is overwritten, this information is displayed in the control.

The parameter is used to set whether the overwrite status of a scheduler is displayed in the control.

### 9.11.2 Data points

#### 9.11.2.1 Information value

This data point is enabled when the "Enable information text" parameter is set to "Enabled".

A telegram with the value of the information text area of the control is received via the data point.

**9.12 Control "Blind switch"**

A blind control can be set up via the "Blind button" control. This allows an allocated blind to be operated.



**Notice**

All adjustable parameters in the "General" tab are available in Chapter 9.1 "General parameters" on page 91.

**9.12.1 Parameters**

**9.12.1.1 Type of blind**

Options:	Blind horiz.
	Blind vert.
	Roller shutter

- Blind horiz.:
  - Setting for horizontal blind types.
- Blind vert.:
  - Setting for vertical blind types.
- Roller shutter:
  - Settings for roller shutters.

The parameter is used to set the type of blind.

**9.12.1.2 Behaviour of the control**

Options:	Perform action with release
	Perform action with press of the button

- Perform action with press of the button:
  - Actions are performed by pressing the buttons.
- Perform action with release:
  - Actions are performed by releasing the buttons.

The parameter is used to set the behaviour that triggers actions.

**9.12.1.3 Animation timeout**

Options:	Setting option from 30 to 180 (s)
----------	-----------------------------------

The parameter is used to set the time after the expiry of which the animations are paused in the control when no actuator status message is received.

The time can be set in steps of one second (min.: 30 - max.: 180).

**9.12.1.4 Data point for status notifications**

Options:	None
	Status upper/lower end position
	Status value

- None:
  - No data points for receiving the position information of the actuator have been enabled.
- Status upper/lower end position
  - The data points for "Status upper end position" and "Status lower end position" are enabled.
- Status value:
  - The data point for the status value is enabled.

The parameter is used to enable data points for receiving the position information of the actuator.

**9.12.1.5 Title information**

Options:	<Title information>
----------	---------------------

With this parameter a custom text for the description of the information type displayed in the control can be specified. The length of the text is limited to 30 characters.



**Notice**

The parameter is only adjustable if the "Enable information text" parameter is set to "Enabled".

**9.12.1.6 Standard information text**

Options:	<Standard information text>
----------	-----------------------------

This parameter can be used to specify a custom text for the standard information text. The length of the text is limited to 30 characters.



**Notice**

The parameter is only adjustable if the "Enable information text" parameter is set to "Enabled".

## 9.12.1.7 Decimal places for information value

Options:	Setting option from 0 to 5
----------	----------------------------

This parameter can be used to set the number of decimal places that are displayed for numerical values in the information field.

The delay time can be set in steps of one millisecond (min.: 0 - max.: 5).



### Notice

The parameter is only adjustable if the "Enable information text" parameter is set to "Enabled".

## 9.12.1.8 Representation in control

Options:	Symbols
	Symbols with text
	Text

- Symbols:
  - Functions are only presented in the form of symbols.
- Symbols with text:
  - Functions are presented in the form of symbols with text.
- Text:
  - Functions are only presented in the form of text.

The parameter is used to specify how functions are presented in the control. Also symbols, text or a mixture of symbols and text can be displayed in the control.



**9.12.1.9 Symbol for move direction**

Options:	Custom (if available)
	Lighting
	Communication
	Energy
	Function
	Multi-media
	Navigation
	Notification
	Object
	Location
	Scene
	System
	Temperature
	Window and door

- Custom (if available)
- Function
- Communication
- Energy
- Lighting
- Multi-media
- Navigation
- Notification
- Object
- Scene
- System
- Location
- Temperature
- Window and door

This parameter is used to select any symbol from the various listed categories in the symbols library. The symbol determines how the buttons for move direction are displayed within the control.

**9.12.1.10 Symbol for "Step up"**

Options:	Custom (if available)
	Lighting
	Communication
	Energy
	Function
	Multi-media
	Navigation
	Notification
	Object
	Location
	Scene
	System
	Temperature
	Window and door

- Custom (if available)
- Function
- Communication
- Energy
- Lighting
- Multi-media
- Navigation
- Notification
- Object
- Scene
- System
- Location
- Temperature
- Window and door

This parameter is used to select any symbol from the various listed categories in the symbols library. The symbol determines how the button for action "Step up" is displayed within the control.



**Notice**

The parameter can only be set when the "Blind horiz." option is set under "Type of blind".

9.12.1.11 Symbol for "Step down"

Options:	Custom (if available)
	Lighting
	Communication
	Energy
	Function
	Multi-media
	Navigation
	Notification
	Object
	Location
	Scene
	System
	Temperature
	Window and door

- Custom (if available)
- Function
- Communication
- Energy
- Lighting
- Multi-media
- Navigation
- Notification
- Object
- Scene
- System
- Location
- Temperature
- Window and door

This parameter is used to select any symbol from the various listed categories in the symbols library. The symbol determines how the button for action "Step down" is displayed within the control.



**Notice**

The parameter can only be set when the "Blind horiz." option is set under "Type of blind".

**9.12.1.12 Symbol for "Move up"**

Options:	Custom (if available)
	Lighting
	Communication
	Energy
	Function
	Multi-media
	Navigation
	Notification
	Object
	Location
	Scene
	System
	Temperature
	Window and door

- Custom (if available)
- Function
- Communication
- Energy
- Lighting
- Multi-media
- Navigation
- Notification
- Object
- Scene
- System
- Location
- Temperature
- Window and door

This parameter is used to select any symbol from the various listed categories in the symbols library. The symbol determines how the button for action "Move up" is displayed within the control.



**Notice**

The parameter can only be set when the "Blind horiz." option is set under "Type of blind".

9.12.1.13 Symbol for "Move down"

Options:	Custom (if available)
	Lighting
	Communication
	Energy
	Function
	Multi-media
	Navigation
	Notification
	Object
	Location
	Scene
	System
	Temperature
	Window and door

- Custom (if available)
- Function
- Communication
- Energy
- Lighting
- Multi-media
- Navigation
- Notification
- Object
- Scene
- System
- Location
- Temperature
- Window and door

This parameter is used to select any symbol from the various listed categories in the symbols library. The symbol determines how the button for action "Move down" is displayed within the control.



**Notice**

The parameter can only be set when the "Blind horiz." option is set under "Type of blind".

**9.12.1.14 Symbol for "Step left"**

Options:	Custom (if available)
	Lighting
	Communication
	Energy
	Function
	Multi-media
	Navigation
	Notification
	Object
	Location
	Scene
	System
	Temperature
	Window and door

- Custom (if available)
- Function
- Communication
- Energy
- Lighting
- Multi-media
- Navigation
- Notification
- Object
- Scene
- System
- Location
- Temperature
- Window and door

This parameter is used to select any symbol from the various listed categories in the symbols library. The symbol determines how the button for action "Step left" is displayed within the control.



**Notice**

The parameter can only be set when the "Blind vert." option is set under "Type of blind".

**9.12.1.15 Symbol for "Step right"**

Options:	Custom (if available)
	Lighting
	Communication
	Energy
	Function
	Multi-media
	Navigation
	Notification
	Object
	Location
	Scene
	System
	Temperature
	Window and door

- Custom (if available)
- Function
- Communication
- Energy
- Lighting
- Multi-media
- Navigation
- Notification
- Object
- Scene
- System
- Location
- Temperature
- Window and door

This parameter is used to select any symbol from the various listed categories in the symbols library. The symbol determines how the button for action "Step right" is displayed within the control.



**Notice**

The parameter can only be set when the "Blind vert." option is set under "Type of blind".

**9.12.1.16 Symbol for "Move left"**

Options:	Custom (if available)
	Lighting
	Communication
	Energy
	Function
	Multi-media
	Navigation
	Notification
	Object
	Location
	Scene
	System
	Temperature
	Window and door

- Custom (if available)
- Function
- Communication
- Energy
- Lighting
- Multi-media
- Navigation
- Notification
- Object
- Scene
- System
- Location
- Temperature
- Window and door

This parameter is used to select any symbol from the various listed categories in the symbols library. The symbol determines how the button for action "Move left" is displayed within the control.



**Notice**

The parameter can only be set when the "Blind vert." option is set under "Type of blind".



**9.12.1.17 Symbol for "Move right"**

Options:	Custom (if available)
	Lighting
	Communication
	Energy
	Function
	Multi-media
	Navigation
	Notification
	Object
	Location
	Scene
	System
	Temperature
	Window and door

- Custom (if available)
- Function
- Communication
- Energy
- Lighting
- Multi-media
- Navigation
- Notification
- Object
- Scene
- System
- Location
- Temperature
- Window and door

This parameter is used to select any symbol from the various listed categories in the symbols library. The symbol determines how the button for action "Move right" is displayed within the control.



**Notice**

The parameter can only be set when the "Blind vert." option is set under "Type of blind".

**9.12.1.18 Symbol for "Stop"**

Options:	Custom (if available)
	Lighting
	Communication
	Energy
	Function
	Multi-media
	Navigation
	Notification
	Object
	Location
	Scene
	System
	Temperature
	Window and door

- Custom (if available)
- Function
- Communication
- Energy
- Lighting
- Multi-media
- Navigation
- Notification
- Object
- Scene
- System
- Location
- Temperature
- Window and door

This parameter is used to select any symbol from the various listed categories in the symbols library. The symbol determines how the button for action "Stop" is displayed within the control.

### 9.12.2 Data points

#### 9.12.2.1 Move up/down

The data point is used to move the blind up and down with the preset values set under the parameters.

#### 9.12.2.2 Stop / slat adjustment

This communication object is enabled when parameter "Type of blind" has been parameterised to "Blind horiz." or "Blind vert.".

The data point is used to send a single step command for moving the blind up or down.

#### 9.12.2.3 Status upper end position

This data point is enabled when parameter "Data point for status notifications" has been parameterised to "Status upper/lower end position".

A status telegram is received via the data point when the upper end position has been reached.

#### 9.12.2.4 Status lower end position

This data point is enabled when parameter "Data point for status notifications" has been parameterised to "Status upper/lower end position".

A status telegram is received via the data point when the lower end position has been reached.

#### 9.12.2.5 Status height

This data point is enabled when parameter "Data point for status notifications" has been parameterised to "Status value".

A status telegram is received via the data point when the specified position has been reached.

#### 9.12.2.6 Wind alarm

When this data point is received, the control is deactivated if, for example, a wind alarm message is sent from the weather station.

#### 9.12.2.7 Information value

This data point is enabled when the "Enable information text" parameter is set to "Enabled".

A telegram with the value of the information text area of the control is received via the data point.

#### 9.12.2.8 Disable

The operating functions of the control are disabled via the data point.

**9.13 Control "Blind slider"**

A blind control can be set up via the "Blind slider" control. This allows an allocated blind to be operated.

The control differentiates itself from the "Blind slider" control in that a slider instead of a switch is used.



**Notice**

All adjustable parameters in the "General" tab are available in Chapter 9.1 "General parameters" on page 91.

**9.13.1 Parameters**

**9.13.1.1 Type of blind**

Options:	Blind horiz.
	Blind vert.
	Roller shutter

- Blind horiz.:
  - Setting for horizontal blind types.
- Blind vert.:
  - Setting for vertical blind types.
- Roller shutter:
  - Settings for roller shutters.

The parameter is used to set the type of blind.

**9.13.1.2 Animation timeout**

Options:	Setting option from 30 to 180 (s)
----------	-----------------------------------

The parameter is used to set the time after the expiry of which the animations are paused in the control when no actuator status message is received.

The time can be set in steps of one second (min.: 30 - max.: 180).

**9.13.1.3 Title information**

Options:	<Title information>
----------	---------------------

With this parameter a custom text for the description of the information type displayed in the control can be specified. The length of the text is limited to 30 characters.



**Notice**

The parameter is only adjustable if the "Enable information text" parameter is set to "Enabled".

## 9.13.1.4 Standard information text

Options:	<Standard information text>
----------	-----------------------------

This parameter can be used to specify a custom text for the standard information text. The length of the text is limited to 30 characters.



### Notice

The parameter is only adjustable if the "Enable information text" parameter is set to "Enabled".

## 9.13.1.5 Decimal places for information value

Options:	Setting option from 0 to 5
----------	----------------------------

This parameter can be used to set the number of decimal places that are displayed for numerical values in the information field.

The delay time can be set in steps of one millisecond (min.: 0 - max.: 5).



### Notice

The parameter is only adjustable if the "Enable information text" parameter is set to "Enabled".

**9.13.1.6 Symbol for move direction**

Options:	Custom (if available)
	Lighting
	Communication
	Energy
	Function
	Multi-media
	Navigation
	Notification
	Object
	Location
	Scene
	System
	Temperature
	Window and door

- Custom (if available)
- Function
- Communication
- Energy
- Lighting
- Multi-media
- Navigation
- Notification
- Object
- Scene
- System
- Location
- Temperature
- Window and door

This parameter is used to select any symbol from the various listed categories in the symbols library. The symbol determines how the buttons for move direction are displayed within the control.

**9.13.1.7 Text for change of height**

Options:	<Text for change height>
----------	--------------------------

The parameter is used to specify the text that is displayed next to the blind slider of the control. The maximum length of the text is limited to 20 characters.

**9.13.1.8 Symbol for adjusting the slats**

Options:	Custom (if available)
	Lighting
	Communication
	Energy
	Function
	Multi-media
	Navigation
	Notification
	Object
	Location
	Scene
	System
	Temperature
	Window and door

- Custom (if available)
- Function
- Communication
- Energy
- Lighting
- Multi-media
- Navigation
- Notification
- Object
- Scene
- System
- Location
- Temperature
- Window and door

This parameter is used to select any symbol from the various listed categories in the symbols library. The symbol determines how the button for adjusting the blind slats is represented within the control.



**Notice**

The parameter can only be set when the "Blind horiz." or "Blind vert." option is set under "Type of blind".

## 9.13.1.9 Text for adjust slats

Options:

<Text for adjust slats>

The parameter is used to specify the text that is displayed for the alignment of the blind slats on the control.



### Notice

The parameter can only be set when the "Blind horiz." or "Blind vert." option is set under "Type of blind".

## 9.13.2 Data points

### 9.13.2.1 Move to pos. height

The parameter is used to send a telegram with the new blind position.

### 9.13.2.2 Move slats

This data point is enabled when parameter "Type of blind" has been parameterised to "Blind horiz." or "Blind vert.".

The data point is used to send a telegram with the new slat position.

### 9.13.2.3 Status height

This data point is enabled when parameter "Data point for status notifications" has been parameterised to "Status value".

A status telegram is received via the data point when the specified position has been reached.

### 9.13.2.4 Status slat

This data point is enabled when parameter "Type of blind" has been parameterised to "Blind horiz." or "Blind vert.".

The data point is used to receive a telegram with the slat position sent by the blind actuator.

### 9.13.2.5 Status upper end position

This data point is enabled when parameter "Data point for status notifications" has been parameterised to "Status upper/lower end position".

A status telegram is received via the data point when the upper end position has been reached.



### **9.13.2.6 Status lower end position**

This data point is enabled when parameter "Data point for status notifications" has been parameterised to "Status upper/lower end position".

A status telegram is received via the data point when the lower end position has been reached.

### **9.13.2.7 Wind alarm**

When this data point is received, the control is deactivated if, for example, a wind alarm message is sent from the weather station.

### **9.13.2.8 Information value**

This data point is enabled when the "Enable information text" parameter is set to "Enabled".

A telegram with the value of the information text area of the control is received via the data point.

### **9.13.2.9 Disable**

The operating functions of the control are disabled via the data point.

**9.14 Control "Switch"**

You can, among others, set up a light control via the "Switch" control. An allocated lamp can then be switched via the control. However, also an insert can be used as push-button or scene control.



**Notice**

All adjustable parameters in the "General" tab are available in Chapter 9.1 "General parameters" on page 91.

**9.14.1 Parameters**

**9.14.1.1 Send datapoint**

Options:	ON only
	ON and OFF
	OFF only

- OFF only:
  - Only the OFF status is sent.
- ON and OFF:
  - The ON and OFF statuses are sent.
- ON only:
  - Only the ON status is sent.

The parameter is used to set the status for which communication objects are sent.

**9.14.1.2 Behaviour of the control**

Options:	Distinction between a short and long press
	Send value for "ON" with a press of the button, send value "OFF" when released
	Switchover between "ON/OFF" when pressed
	Switchover between "ON/OFF" status when released

- Distinction between a short and long press:
  - The light is switched on with a short press of the control. The light is switched off with a long press of the control.
- Send value for "ON" with a press of the button, send value "OFF" when released:
  - When the control is pressed, a data point for switching on is sent. A data point for switching off is sent when the control is released.
- Switchover between "ON/OFF" with a press of the button:
  - There is a switchover between the status "On" and "Off" with a press of the switch.
- Switchover between "ON/OFF" when released:
  - There is a switchover between the status "On" and "Off" when the switch is released.

The parameter is used to specify the behaviour of the control when pressed or released.

## 9.14.1.3 Title information

Options:	<Title information>
----------	---------------------

With this parameter a custom text for the description of the information type displayed in the control can be specified. The length of the text is limited to 30 characters.



### Notice

The parameter is only adjustable if the "Enable information text" parameter is set to "Enabled".

## 9.14.1.4 Standard information text

Options:	<Standard information text>
----------	-----------------------------

This parameter can be used to specify a custom text for the standard information text. The length of the text is limited to 30 characters.



### Notice

The parameter is only adjustable if the "Enable information text" parameter is set to "Enabled".

## 9.14.1.5 Decimal places for information value

Options:	Setting option from 0 to 5
----------	----------------------------

This parameter can be used to set the number of decimal places that are displayed for numerical values in the information field.

The delay time can be set in steps of one millisecond (min.: 0 - max.: 5).



### Notice

The parameter is only adjustable if the "Enable information text" parameter is set to "Enabled".

**9.14.1.6 Representation in control**

Options:	Symbols
	Symbols with text
	Text

- Symbols:
  - Functions are only presented in the form of symbols.
- Symbols with text:
  - Functions are presented in the form of symbols with text.
- Text:
  - Functions are only presented in the form of text.

The parameter is used to specify how functions are presented in the control. Also symbols, text or a mixture of symbols and text can be displayed in the control.

**9.14.1.7 Symbol for "ON"**

Options:	Custom (if available)
	Lighting
	Communication
	Energy
	Function
	Multi-media
	Navigation
	Notification
	Object
	Location
	Scene
	System
	Temperature
	Window and door

- Custom (if available)
- Function
- Communication
- Energy
- Lighting
- Multi-media
- Navigation
- Notification
- Object
- Scene
- System
- Location
- Temperature
- Window and door

This parameter is used to select any symbol from the various listed categories in the symbols library. The symbol determines how the "ON" status is displayed in the control.

**9.14.1.8 Symbol for "OFF"**

Options:	Custom (if available)
	Lighting
	Communication
	Energy
	Function
	Multi-media
	Navigation
	Notification
	Object
	Location
	Scene
	System
	Temperature
	Window and door

- Custom (if available)
- Function
- Communication
- Energy
- Lighting
- Multi-media
- Navigation
- Notification
- Object
- Scene
- System
- Location
- Temperature
- Window and door

This parameter is used to select any symbol from the various listed categories in the symbols library. The symbol determines how the "OFF" status is displayed in the control.

9.14.1.9 Symbol for "Undefined"

Options:	Custom (if available)
	Lighting
	Communication
	Energy
	Function
	Multi-media
	Navigation
	Notification
	Object
	Location
	Scene
	System
	Temperature
	Window and door

- Custom (if available)
- Function
- Communication
- Energy
- Lighting
- Multi-media
- Navigation
- Notification
- Object
- Scene
- System
- Location
- Temperature
- Window and door

This parameter is used to select any symbol from the various listed categories in the symbols library. The symbol determines how the button of the control is displayed when there is an undefined status.

**9.14.2 Data points**

**9.14.2.1 Switch command**

The 1-bit data point is used to send On and Off telegrams.

Telegram value:	0 = OFF The switch is on position OFF.
	1 = ON The switch is on position ON

**9.14.2.2 Switching status**

A status telegram is received via the data point.

Telegram value:	0 = OFF The switch is on position OFF.
	1 = ON The switch is on position ON

**9.14.2.3 Information value**

This data point is enabled when the "Enable information text" parameter is set to "Enabled".

A telegram with the value of the information text area of the control is received via the data point.

**9.14.2.4 Disable**

The operating functions of the control are disabled via the data point.



**9.15 Control "Trend viewer"**

Selected trends can be visualised via the "Trend viewer" control.

If one or several values have been assigned to the control, corresponding value diagrams are displayed in the "Trend viewer" control.



**Notice**

All adjustable parameters in the "General" tab are available in Chapter 9.1 "General parameters" on page 91.

**9.15.1 Parameters**

**9.15.1.1 Title information**

Options:	<Title information>
----------	---------------------

With this parameter a custom text for the description of the information type displayed in the control can be specified. The length of the text is limited to 30 characters.



**Notice**

The parameter is only adjustable if the "Enable information text" parameter is set to "Enabled".

**9.15.1.2 Standard information text**

Options:	<Standard information text>
----------	-----------------------------

This parameter can be used to specify a custom text for the standard information text. The length of the text is limited to 30 characters.



**Notice**

The parameter is only adjustable if the "Enable information text" parameter is set to "Enabled".

**9.15.1.3 Decimal places for information value**

Options:	Setting option from 0 to 5
----------	----------------------------

This parameter can be used to set the number of decimal places that are displayed for numerical values in the information field.

The delay time can be set in steps of one millisecond (min.: 0 - max.: 5).



**Notice**

The parameter is only adjustable if the "Enable information text" parameter is set to "Enabled".

**9.15.1.4 Display setting**

Options:	Standard display
	New policy

- Standard display:
  - The standard display options are used for the representation of trends.
- New policy:
  - Individually defined display options are used for the representation of trends.

The parameter is used to set the display options that are selected in the control for the representation of trends.

**9.15.1.5 Y-Axis**

Options:	deactivated
	activated

- Disabled:
  - No X-axis is displayed in the graphs.
- Enabled:
  - The X-axis is displayed in the graphs.

The parameter is used to set whether the X-axis is displayed in the graphs of the control.

**9.15.1.6 Y-Axis**

Options:	deactivated
	activated

- Disabled:
  - No Y-axis is displayed in the graphs.
- Enabled:
  - The Y-axis is displayed in the graphs.

The parameter is used to set whether the Y-axis is displayed in the graphs of the control.

**9.16 Control "Value for slider"**

The values of a selected element (group address) can be displayed and at the same time adjusted via the slider using the "Value slider" control. When adjusted, the values are displayed directly in updated form. This allows values to be sent and received via this function.

If a "Value slider" control is created in the user interface, the desired category and dimensional unit (e.g. percent) must have been specified already during the creation of the control. The specified dimensional unit cannot be changed at a later point in time.



**Notice**

All adjustable parameters in the "General" tab are available in Chapter 9.1 "General parameters" on page 91.

**9.16.1 Parameters**

**9.16.1.1 Unit**

Options:	
	Data volume
	Electric admittance
	Illuminance
	Range
	Acceleration
	Irradiance
	Duration
	Torque
	Rotational speed
	Pressure
	Electric field strength
	Electric charge
	Electrical conductivity
	Electric current density
	Electric current
	Electric resistance
	Electric dipole moment
	Electric potential
	Energy
	Energy per material volume category
	Flow
	Frequency
	Speed
	Inductance
	Capacities
	Kelvin per percent
	KNX meter
	Force
	Charge density surface
	Charge density volume
	Length

Power
Power factor
Luminance
Luminous intensity
Luminous flux
Magnetic field strength
Magnetic flux density
Magnetic flux
Magnetic moment
Mass
Mass flow
Momentum
Surface tension
Solid angle
Specific weight
Amount of substance
Temperature
Temperature change rate
Thermoelectric power
Ratio
Volume
Heat capacity
Thermal conductivity
Angle
Angular acceleration

This parameter is used to set the dimensional unit in which the values are measured in the control. Different dimensional units are allocated to the categories listed above.



**Notice**

When the control is added to the operating page, the dimensional unit must be specified.

### 9.16.1.2 Display status value

Options:	deactivated
	activated

- Disabled:
  - The current value is not displayed.
- Enabled:
  - The current value is displayed.

The parameter is used to set whether the current value is to be displayed in the control.

### 9.16.1.3 Number of decimals

Options:	Setting option from 0 to 3
----------	----------------------------

The parameter is used to specify the number of decimal places the presented values should have.

The number can be set in steps from one decimal place (min.: 0 - max.: 3).



**Notice**

The parameter "Number of decimals" is only adjustable if the "Display status value" parameter is set to "Enabled".

### 9.16.1.4 Activate long press

Options:	deactivated
	activated

- Disabled:
  - The settings for the behaviour at a long press of the button are disabled.
- Enabled:
  - The settings for the behaviour at a long press of the button are enabled.

The parameter is used to enable or disable the behaviour for a long press of the button.

## 9.16.1.5 Time interval

Options:	Setting option from 0.3 to 0.7 (s)
----------	------------------------------------

The parameter is used to set the time interval between the sending of messages at a long press of the button.

The time interval can be set in decimal steps of 0.1 (min.: 0.3 - max.: 0.7).



### Notice

The parameter is only adjustable if the "Activate long press" parameter is set to "Enabled".

## 9.16.1.6 Step size

Options:	Setting option from 0 to 100 (%)
----------	----------------------------------

The parameter is used to set the smallest possible step size with which the control can be set.

The step size can be set in percentage steps (min.: 0% - max. 100%).

## 9.16.1.7 Step width (fine adjustment)

Options:	Setting option from 0 to 100 (%)
----------	----------------------------------

The parameter is used to set the increment of the value when clicking on the up or down button.

## 9.16.1.8 Minimum value

Options:	Setting option from 0 to 100 (%)
----------	----------------------------------

The parameter is used to set the smallest value.

The value can be set in percentage steps (min.: 0% - max. 100%).

## 9.16.1.9 Maximum value

Options:	Setting option from 0 to 100 (%)
----------	----------------------------------

The parameter is used to set the largest value.

The value can be set in percentage steps (min.: 0% - max. 100%).

## 9.16.1.10 Exchange orientation

Options:	deactivated
	activated

The parameter is used to set whether the maximum value is displayed on the left or the right side of the slider control.

## 9.16.1.11 Title information

Options:	<Title information>
----------	---------------------

With this parameter a custom text for the description of the information type displayed in the control can be specified. The length of the text is limited to 30 characters.



### Notice

The parameter is only adjustable if the "Enable information text" parameter is set to "Enabled".

## 9.16.1.12 Standard information text

Options:	<Standard information text>
----------	-----------------------------

This parameter can be used to specify a custom text for the standard information text. The length of the text is limited to 30 characters.



### Notice

The parameter is only adjustable if the "Enable information text" parameter is set to "Enabled".

## 9.16.1.13 Decimal places for information value

Options:	Setting option from 0 to 5
----------	----------------------------

This parameter can be used to set the number of decimal places that are displayed for numerical values in the information field.

The delay time can be set in steps of one millisecond (min.: 0 - max.: 5).



### Notice

The parameter is only adjustable if the "Enable information text" parameter is set to "Enabled".

## 9.16.1.14 Display text for "Position out of range"

Options:	deactivated
	activated

- Disabled:
  - A value received out of range is displayed.
- Enabled:
  - In place of a received value outside the range, a text is displayed.

This parameter is used to specify that in case of a value that is lies outside the specified range, a text is displayed instead of a value.

### 9.16.1.15 Text for "Position out of range"

Options:

<Text for "Position out of range">
------------------------------------

The parameter is used to specify the text that is to be displayed for a position outside the defined range.



### 9.16.2 Data points

#### 9.16.2.1 Command value

The current value of the switch is sent via the data point.

#### 9.16.2.2 Status value

A status telegram with the current value of the switch is received via the data point.

#### 9.16.2.3 Information value

This data point is enabled when the "Enable information text" parameter is set to "Enabled".

A telegram with the value of the information text area of the control is received via the data point.

#### 9.16.2.4 Disable

The operating functions of the control are disabled via the data point.

**9.17 Control "Weather"**

Different weather-related values can be displayed via the "Weather" control, such as wind speed, humidity, sunrise or sunset times.

The control only serves as display element. The arrows left and right can be used to switch manually between different weather information.



**Notice**

All adjustable parameters in the "General" tab are available in Chapter 9.1 "General parameters" on page 91.

**9.17.1 Parameters**

**9.17.1.1 Automated display mode**

Options:	deactivated
	activated

- Disabled:
  - Switching through the weather data must be carried out manually.
- Enabled:
  - The display switches through the weather data automatically.

If the parameter is enabled, the display in the control switches through the different weather data automatically.

**9.17.1.2 Switching time**

Options:	Setting option from 1 to 59
----------	-----------------------------

The parameter is used to specify the interval at which switching from one value to the other takes place.

The time can be set at intervals starting from 1 second (min.: 1 - max.: 59).

**9.17.1.3 Title information**

Options:	<Title information>
----------	---------------------

With this parameter a custom text for the description of the information type displayed in the control can be specified. The length of the text is limited to 30 characters.



**Notice**

The parameter is only adjustable if the "Enable information text" parameter is set to "Enabled".

**9.17.1.4 Standard information text**

Options:	<Standard information text>
----------	-----------------------------

This parameter can be used to specify a custom text for the standard information text. The length of the text is limited to 30 characters.



**Notice**

The parameter is only adjustable if the "Enable information text" parameter is set to "Enabled".

**9.17.1.5 Decimal places for information value**

Options:	Setting option from 0 to 5
----------	----------------------------

This parameter can be used to set the number of decimal places that are displayed for numerical values in the information field.

The delay time can be set in steps of one millisecond (min.: 0 - max.: 5).



**Notice**

The parameter is only adjustable if the "Enable information text" parameter is set to "Enabled".

**9.17.1.6 Show measured temperature**

Options:	deactivated
	activated

- Disabled:
  - The temperature determined by the external sensor is not displayed in the control.
- Enabled:
  - The temperature determined by the external sensor is displayed in the control.

This parameter is used to set whether the temperature determined by the external sensor is to be displayed in the control.

## 9.17.1.7 Display felt temperature

Options:	deactivated
	activated

- Disabled:
  - The felt temperature is not displayed in the control.
- Enabled:
  - The felt temperature is displayed in the control.

This parameter is used to set whether the temperature determined and actually felt by the external sensor is to be displayed in the control.

## 9.17.1.8 Display wind speed

Options:	deactivated
	activated

- Disabled:
  - The wind speed is not displayed in the control.
- Enabled:
  - The wind speed is displayed in the control.

This parameter is used to set whether the wind speed is to be displayed in the control.

## 9.17.1.9 Display humidity

Options:	deactivated
	activated

- Disabled:
  - The relative humidity is not displayed in the control.
- Enabled:
  - The relative humidity is displayed in the control.

This parameter is used to set whether the relative humidity is to be displayed in the control.

## 9.17.1.10 Display brightness

Options:	deactivated
	activated

- Disabled:
  - The current brightness value of the sun is not displayed in the control.
- Enabled:
  - The current brightness value of the sun is displayed in the control.

This parameter is used to set whether the brightness value of the sun is to be displayed in the control.

## 9.17.1.11 Display precipitation

Options:	deactivated
	activated

- Disabled:
  - Symbols for rain or sun are not displayed in the control.
- Enabled:
  - Symbols for rain or sun are displayed in the control.

This parameter is used to set whether the symbols for rain or sun are to be displayed in the control.

## 9.17.1.12 Display day/night

Options:	deactivated
	activated

- Disabled:
  - Symbols for day or night are not displayed in the control.
- Enabled:
  - Symbols for day or night are displayed in the control.

This parameter is used to set whether the symbols for day or night are to be displayed in the control.

## 9.17.1.13 Display air pressure

Options:	deactivated
	activated

- Disabled:
  - The air pressure is not displayed in the control.
- Enabled:
  - The air pressure is displayed in the control.

This parameter is used to set whether the air pressure is to be displayed in the control.

## 9.17.1.14 Display date/time

Options:	deactivated
	activated

- Disabled:
  - Date and time are not displayed in the control.
- Enabled:
  - Date and time are displayed in the control.

This parameter is used to set whether the date and time are to be displayed in the control.

## 9.17.1.15 Display sunrise / sunset

Options:	deactivated
	activated

- Disabled:
  - Times for sunrise and sunset are not displayed in the control.
- Enabled:
  - Times for sunrise and sunset are displayed in the control.

This parameter is used to set whether the times for sunrise and sunset are to be displayed in the control.

**9.17.1.16 Display building position**

Options:	deactivated
	activated

- Disabled:
  - The coordinates of the building position are not displayed in the control.
- Enabled:
  - The coordinates of the building position are displayed in the control.

This parameter is used to set whether the coordinates of the building position are to be displayed in the control.

**9.17.1.17 Unit of wind speed**

Options:	Bft
	km/h
	m/s
	mi/h

- Bft:
  - The measurement is carried out in Bft.
- km/h:
  - The measurement is carried out in km/h.
- m/s:
  - The measurement is carried out in m/s.
- mi/h:
  - The measurement is carried out in mi//h.

The parameter is used to set the dimensional unit in which the wind speed is displayed in the control.



**Notice**

The parameter is only adjustable if the "Display wind speed" parameter is set to "Enabled".

## 9.17.1.18 Temperature unit

Options:	°C
	°F

- °C:
  - The temperature value is displayed in Celsius.
- °F:
  - The temperature value is displayed in Fahrenheit.

The parameter is used to set the dimensional unit of the temperature displayed in the control.



### Notice

The parameter is only adjustable if at least one of the parameters "Display measured temperature" or "Display felt temperature" is set to "Enabled".



### 9.17.2 Data points

#### 9.17.2.1 Information value

This data point is enabled when the "Enable information text" parameter is set to "Enabled".

A telegram with the value of the information text area of the control is received via the data point.

#### 9.17.2.2 Temperature value

This data point is enabled when the "Display measured temperature" parameter is set to "Enabled".

A status telegram with the current temperature is received via the data point.

#### 9.17.2.3 Felt temperature value

This data point is enabled when the "Display felt temperature" parameter is set to "Enabled".

A status telegram with the current felt temperature is received via the data point.

#### 9.17.2.4 Wind speed

This data point is enabled when the "Display wind speed" parameter is set to "Enabled".

A status telegram with the current wind speed is received via the data point.

#### 9.17.2.5 Relative humidity

This data point is enabled when the "Display humidity" parameter is set to "Enabled".

A status telegram with the current relative humidity is received via the data point.

#### 9.17.2.6 Brightness value

This data point is enabled when the "Display brightness" parameter is set to "Enabled".

A status telegram with the current brightness value is received via the data point.

#### 9.17.2.7 Precipitation

This data point is enabled when the "Precipitation" parameter is set to "Enabled".

A status telegram that signals whether it is raining or sunny is received via the data point.

#### 9.17.2.8 Day/Night

This data point is enabled when the "Day/Night" parameter is set to "Enabled".

A status telegram that signals whether it is day or night is received via the data point.

#### 9.17.2.9 Air pressure value

This data point is enabled when the "Display air pressure" parameter is set to "Enabled".

A status telegram with the current air pressure is received via the data point.

### **9.17.2.10 GPS longitude**

The data point is enabled when the "Display building position" parameter is set to "Enabled".  
A status telegram with the current position of the sun is received via the data point.

### **9.17.2.11 GPS latitude**

This data point is enabled when the "Display building position" parameter is set to "Enabled".  
A status telegram with the current position of the sun is received via the data point.

### **9.17.2.12 Date**

This data point is enabled when the "Date/Time" parameter is set to "Enabled".  
A status telegram with the current date is received via the data point.

### **9.17.2.13 Time of day**

This data point is enabled when the "Date/Time" parameter is set to "Enabled".  
A status telegram with the current time is received via the data point.

### **9.17.2.14 Time of sunrise**

This data point is enabled when the "Display sunrise/sunset" parameter is set to "Enabled".  
A status telegram with the time of sunrise is received via the data point.

### **9.17.2.15 Time of sunset**

This data point is enabled when the "Display sunrise/sunset" parameter is set to "Enabled".  
A status telegram with the time of sunset is received via the data point.

### **9.17.2.16 General sensor failure**

A status telegram is sent via the data point when a general sensor failure has occurred.

### **9.17.2.17 Error during time synchronization**

The data point is enabled when the "Date/Time" parameter is set to "Enabled".  
A status telegram is sent via the data point when there is an interruption during the time synchronisation.

### **9.17.2.18 Brightness sensor disrupted**

The data point is enabled when the "Display brightness" parameter is set to "Enabled".  
A status telegram is sent via the data point when there is a failure on the brightness sensor.

### **9.17.2.19 Twilight sensor disrupted**

The data point is enabled when the "Display sunrise/sunset" parameter is set to "Enabled".  
A status telegram is sent via the data point when there is a failure on the twilight sensor.

### **9.17.2.20 Day/night sensor disrupted**

The data point is enabled when the "Day/Night" parameter is set to "Enabled".

A status telegram is sent via the data point when there is an error on the day/night sensor.

### **9.17.2.21 Wind sensor disrupted**

The data point is enabled when the "Display wind speed" parameter is set to "Enabled".

A status telegram is sent via the data point when there is a failure on the wind sensor.

**9.18 Control "DALI light"**

A DALI gateway is required to allow the "DALI light" control to be used. The DALI lamps and lights are not enabled directly via the DALI bus, but indirect via the KNX bus and the KNX/DALI gateway.

Individual lights and also entire light installations can be enabled synchronously via the "DALI light" (e.g. dimming). The control can also provide information about the status of the individual lights, such as defects.



**Notice**

All adjustable parameters in the "General" tab are available in Chapter 9.1 "General parameters" on page 91.

**9.18.1 Parameters**

**9.18.1.1 Supporting dimming functions**

Options:	Dimming On/Off
	ON / OFF

- Dimming On/Off:
  - The DALI light can be dimmed.
- ON/OFF:
  - The DALI light can be switched on and off.

The parameter can be used to set whether the DALI light is to be able to be dimmed or only switched on and off.

If the parameter is set on "Dimming on/off", the data points "Brightness control value" and "Output brightness" are enabled.

**9.18.1.2 Activate long press**

Options:	deactivated
	activated

- Disabled:
  - The settings for the behaviour at a long press of the button are disabled.
- Enabled:
  - The settings for the behaviour at a long press of the button are enabled.

The parameter is used to enable or disable the behaviour for a long press of the button.



**Notice**

The parameter can only be set when the "Dimming On/Off" option is set under "Supporting dimming function".

**9.18.1.3 Actuation at a long press of the button after...**

Options:	Setting option from 0.3 to 0.7 (s)
----------	------------------------------------

The parameter is used to set the time after which a long button press is registered.

The time can be set in steps of 0.3 to 0.7 seconds.



**Notice**

The parameter can only be set when the "Stepwise" option is set under "Type of dimmer".

**9.18.1.4 Step size**

Options:	Setting option from 0 to 100 (%)
----------	----------------------------------

The parameter is used to set the smallest possible step size with which the control can be set.

The step size can be set in percentage steps (min.: 0% - max. 100%).



**Notice**

The parameter can only be set when the "Dimming On/Off" option is set under "Dimmer supported".

**9.18.1.5 At failure of lamp / disable ballast**

Options:	deactivated
	activated

- Enabled:
  - At a failure of the ballast or lamp, the control is disabled.
- Disabled:
  - At a failure of the ballast or lamp, the control remains enabled.

The parameter can be used to set the behaviour of the control at a failure of the ballast or lamp.

**9.18.1.6 Show burn-in state**

Options:	deactivated
	activated

- Disabled:
  - The symbol for the burn-in state is not displayed in the control.
- Enabled:
  - The symbol for the burn-in state is displayed in the control.

The parameter is used to set whether the symbol for the lamp burn-in state is to be displayed in the control.

**9.18.1.7 Burn-in trigger activation**

Options:	deactivated
	activated

- Disabled:
  - The trigger activation of the lamp burn-in is disabled.
- Enabled:
  - The trigger activation of the lamp burn-in is enabled.

The parameter can be used to enable the trigger activation of the lamp burn-in.



**Notice**

The parameter is only adjustable if beforehand the "Show forced operation state" parameter was enabled.

**9.18.1.8 Show forced operation state**

Options:	deactivated
	activated

- Disabled:
  - The status symbol of forced operation is not displayed in the control.
- Enabled:
  - The status symbol of the forced operation state is displayed in the control.

The parameter can be used to set whether the status symbol for forced operation is to be displayed in the control.

**9.18.1.9 Forced operation mode activation**

Options:	deactivated
	activated

- Disabled:
  - The forced operation mode of the light group/ballasts must not be switched over.
- Enabled:
  - The forced operation mode of the light group/ballasts can be switched over.

The parameter is used to set whether the forced operating mode of light groups or ballasts can be switched over.



**Notice**

The parameter is only adjustable if beforehand the "Show forced operation state" parameter was enabled.

**9.18.1.10 Forced operation object type**

Options:	1 bit
	2 bit

- 1 Bit:
  - The object type is 1 Bit.
- 2 Bit:
  - The object type is 2 Bit.

The parameter is used to specify the object type that is used for the switchover of the light group/ballast in the forced operation.



**Notice**

The parameter is only adjustable if beforehand the "Show forced operation state" parameter was enabled.

**9.18.1.11 Title information**

Options:	<Title information>
----------	---------------------

With this parameter a custom text for the description of the information type displayed in the control can be specified. The length of the text is limited to 30 characters.



**Notice**

The parameter is only adjustable if the "Enable information text" parameter is set to "Enabled".

**9.18.1.12 Standard information text**

Options:	<Standard information text>
----------	-----------------------------

This parameter can be used to specify a custom text for the standard information text. The length of the text is limited to 30 characters.



**Notice**

The parameter is only adjustable if the "Enable information text" parameter is set to "Enabled".

**9.18.1.13 Decimal places for information value**

Options:	Setting option from 0 to 5
----------	----------------------------

This parameter can be used to set the number of decimal places that are displayed for numerical values in the information field.

The delay time can be set in steps of one millisecond (min.: 0 - max.: 5).



**Notice**

The parameter is only adjustable if the "Enable information text" parameter is set to "Enabled".

**9.18.1.14 Representation in control**

Options:	Symbols
	Symbols with text
	Text

- Symbols:
  - Functions are only presented in the form of symbols.
- Symbols with text:
  - Functions are presented in the form of symbols with text.
- Text:
  - Functions are only presented in the form of text.

The parameter is used to specify how functions are presented in the control. Also symbols, text or a mixture of symbols and text can be displayed in the control.



**9.18.1.15 Symbol for increase**

Options:	Custom (if available)
	Lighting
	Communication
	Energy
	Function
	Multi-media
	Navigation
	Notification
	Object
	Location
	Scene
	System
	Temperature
	Window and door

- Custom (if available)
- Function
- Communication
- Energy
- Lighting
- Multi-media
- Navigation
- Notification
- Object
- Scene
- System
- Location
- Temperature
- Window and door

This parameter is used to select any symbol from the various listed categories in the symbols library. The symbol determines the look of the button within the control with which the brightness value is increased.

**9.18.1.16 Symbol for decrease**

Options:	Custom (if available)
	Lighting
	Communication
	Energy
	Function
	Multi-media
	Navigation
	Notification
	Object
	Location
	Scene
	System
	Temperature
	Window and door

- Custom (if available)
- Function
- Communication
- Energy
- Lighting
- Multi-media
- Navigation
- Notification
- Object
- Scene
- System
- Location
- Temperature
- Window and door

This parameter is used to select any symbol from the various listed categories in the symbols library. The symbol determines the look of the button within the control with which the brightness value is reduced.

**9.18.1.17 Button position**

Options:	Increase = left / Decrease = right
	Increase = right / Decrease = left

- Increase = left / Decrease = right
  - In the control the button for increasing the brightness value is displayed on the left and the button for decreasing the brightness value on the right.
- Increase = right / Decrease = left
  - In the control the button for increasing the brightness value is displayed on the right and the button for decreasing the brightness value on the left.

The parameter is used to set where the buttons for increasing and reducing the brightness value are positioned.

**9.18.2 Data points**

**9.18.2.1 Information value**

The data point is only adjustable if the "Enable information text" parameter is set to "Enabled"  
 The data point is used to send the stored text for the information area of the control.

**9.18.2.2 Disable**

The operating functions of the control are disabled via the data point.

**9.18.2.3 Switch command**

The 1-bit data point is used to send On and Off telegrams.

Telegram value:	0 = OFF The switch is on position OFF.
	1 = ON The switch is on position ON

**9.18.2.4 Switching status**

A status telegram is received via the data point.

Telegram value:	0 = OFF The switch is on position OFF.
	1 = ON The switch is on position ON

**9.18.2.5 Brightness command**

The communication object is enabled when parameter "Dimmer supported" is set on "Dimming On/Off".

The parameter is used to send a command telegram with the absolute brightness value.

**9.18.2.6 Brightness status**

The communication object is enabled when parameter "Dimmer supported" is set on "Dimming On/Off".

The actuator sends a status telegram with the absolute brightness value via the communication object.

**9.18.2.7 Lamp/ballast failure**

A telegram is received via the data point when there is a failure on the connected light group or ballast.

**9.18.2.8 Forced operation command x Bit**

The data point is enabled when parameter "Show forced operation state" is enabled. The bit value depends on the specified object type of parameter "Forced operation object type".

A command telegram for the forced operation is sent via the data point.

### **9.18.2.9 Forced operation status x Bit**

The data point is enabled when parameter "Show forced operation state" is enabled. The bit value depends on the specified object type of parameter "Forced operation object type".

A telegram with the forced operation status is received via the data point.

### **9.18.2.10 Burn-in lamp command**

The data point is enabled when parameter "Burn-in trigger activation" has been enabled.

A telegram is sent via the data point which triggers the burn-in of the connected light group or ballast.

### **9.18.2.11 Burn-in lamp status**

The data point is enabled when parameter "Show burn-in state" has been enabled.

A telegram with the burn-in status is received via the data point.

**9.19 Control "DALI emergency light"**

A DALI gateway is required to use the "DALI emergency light". The DALI lamps and lights are not enabled directly via the DALI bus, but indirect via the KNX bus and the KNX/DALI gateway.

The information on the state of the DALI emergency light is displayed via the "DALI emergency light" control. The information is represented in the form of different symbols and text, which must be assigned beforehand.

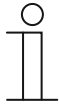

**Notice**

All adjustable parameters in the "General" tab are available in Chapter 9.1 "General parameters" on page 91.

**9.19.1 Parameters**

**9.19.1.1 Style of control**

Options:	Symbols
	Symbols with text
	Text

- Symbols:
  - Functions are only represented in the form of symbols.
- Symbols with text:
  - Functions are represented in the form of symbols with text.
- Text:
  - Functions are only represented in the form of text.

The parameter is used to specify how functions are represented in the control. Also symbols, text or a mixture of symbols and text can be displayed in the control.

**9.19.1.2 Symbol for OK state**

Options:	Custom (if available)
	Lighting
	Communication
	Energy
	Function
	Multi-media
	Navigation
	Notification
	Object
	Location
	Scene
	System
	Temperature
	Window and door

- Custom (if available)
- Function
- Communication
- Energy
- Lighting
- Multi-media
- Navigation
- Notification
- Object
- Scene
- System
- Location
- Temperature
- Window and door

This parameter is used to select any symbol from the various listed categories in the symbols library. The symbol determines how the "OK" status is represented in the button in the control.

**9.19.1.3 Symbol for running test trial state**

Options:	Custom (if available)
	Lighting
	Communication
	Energy
	Function
	Multi-media
	Navigation
	Notification
	Object
	Location
	Scene
	System
	Temperature
	Window and door

- Custom (if available)
- Function
- Communication
- Energy
- Lighting
- Multi-media
- Navigation
- Notification
- Object
- Scene
- System
- Location
- Temperature
- Window and door

This parameter is used to select any symbol from the various listed categories in the symbols library. The symbol determines how the "Running test trial" state is represented in the button in the control.



**9.19.1.4 Symbol for error state**

Options:	Custom (if available)
	Lighting
	Communication
	Energy
	Function
	Multi-media
	Navigation
	Notification
	Object
	Location
	Scene
	System
	Temperature
	Window and door

- Custom (if available)
- Function
- Communication
- Energy
- Lighting
- Multi-media
- Navigation
- Notification
- Object
- Scene
- System
- Location
- Temperature
- Window and door

This parameter is used to select any symbol from the various listed categories in the symbols library. The symbol determines how the "Error status" state is represented in the button in the control.

**9.19.1.5 Symbol for unknown state**

Options:	Custom (if available)
	Lighting
	Communication
	Energy
	Function
	Multi-media
	Navigation
	Notification
	Object
	Location
	Scene
	System
	Temperature
	Window and door

- Custom (if available)
- Function
- Communication
- Energy
- Lighting
- Multi-media
- Navigation
- Notification
- Object
- Scene
- System
- Location
- Temperature
- Window and door

This parameter is used to select any symbol from the various listed categories in the symbols library. The symbol determines how the "Unknown" status is represented in the button in the control.

**9.19.1.6 Colour for OK state**

Options:	<Colour for OK state>
----------	-----------------------

The parameter us used to specify the colour of the text in the "OK" state.

### 9.19.1.7 Colour for running test trial state

Options:

<Colour for running test trial state>
---------------------------------------

The parameter is used to specify the colour of the text in the "Running test trial" state.

### 9.19.1.8 Colour for error state

Options:

<Colour for error state>
--------------------------

The parameter is used to specify the colour of the text in the "Error status" state.

### 9.19.1.9 Colour for unknown state

Options:

<Colour for unknown state>
----------------------------

The parameter is used to specify the colour of the text in the "Unknown" state.

## 9.19.2 Data points

### 9.19.2.1 Disable

The operating functions of the control are disabled via the data point.

### 9.19.2.2 Test result

A status telegram with the results of a ballast test is received via the data point.

### 9.19.2.3 Converter status

A status telegram with the state of the converter is received via the data point.

### 9.19.2.4 Lamp failure

A status telegram is received via the data point at a lamp failure.

### 9.19.2.5 Converter failure

A status telegram is received via the data point in case of a converter failure.

### 9.19.2.6 Lamp aging

A status telegram is received via the data point in case of a burn-in failure on the ballast.

**9.20 Control "RTC"**

The "RTC" control can be used to control an allocated room temperature controller, for example.



**Notice**

All adjustable parameters in the "General" tab are available in Chapter 9.1 "General parameters" on page 91.

**9.20.1 Parameters**

**9.20.1.1 Control functions**

Options:	Temperature
	Temperature and fan speed

- Temperature:
  - The functions for the temperature control are available in the control.
- Temperature and fan speed:
  - The functions for the control of the temperature fan speed are available in the control.

The parameter is used to set the functions that are to be available in the control.

**9.20.1.2 Data point for the setpoint settings**

Options:	Absolute
	Relative
	Stepwise

- Absolute:
  - The bus mode is absolute.
- Relative:
  - The bus mode is relative.
- Stepwise:
  - The bus mode is stepwise

The parameter us used to specify the bus mode for changing the setpoint.

**9.20.1.3 Permit switching between heating and cooling**

Options:	deactivated
	activated

- Disabled:
  - The user cannot switch manually between the heating and cooling functions.
- Enabled:
  - The user can switch manually between the heating and cooling functions.

The parameter is used to set whether the user is allowed to switch manually between the heating and cooling functions.

**9.20.1.4 Heating/Cooling support**

Options:	Cooling
	Heating
	Heating and cooling

- Cooling:
  - The RTC control supports the cooling function.
- Heating:
  - The RTC control supports the heating function.
- Heating and cooling:
  - The RTC control supports the heating and cooling functions.

The parameter is used to set whether the RTC control is to support the functions cooling, heating or heating and cooling.

**9.20.1.5 Permitting the activation of the overwriting mode**

Options:	deactivated
	activated

- Disabled:
  - The overwrite mode must not be able to be enabled by the user.
- Enabled:
  - The overwrite mode can be enabled by the user.

The parameter is used to set whether the user can enable the overwrite mode.

## 9.20.1.6 Temperature step width

Options:	Setting option from 0.2 to 2
----------	------------------------------

The parameter is used to specify the step width for the adjustment of the temperature. The step width can be used for adjusting the absolute setpoint.

## 9.20.1.7 Unit

Options:	Data volume
	Acceleration
	Amount of substance
	Angle
	Rotational acceleration
	Range
	Capacities
	Charge density of surface
	Charge volume of surface
	Compressibility
	Durability
	Electric charge
	Electric current density
	Electric dipole moment
	Electric field strength
	Electric power consumption
	Electrical conductivity
	Electric current
	Electric potential
	Electric resistance
	Specific electric resistance
	Energy
	Energy per volume of material category
	Flow rate
	Strength
	Frequency
	Heating capacity
	Illuminance
	Inductance
	Irradiance
	Kelvin per percent
KNX meter	
Length	
Brightness	
Luminous flux	
Light intensity	
Magnetic field strength	
Magnetic flux	

Magnetic moment
Magnetic flux density
Mass
Mass flow
Momentum
Force
Force factor
Pressure
Ratio
Rotational speed
Solid angle
Specific weight
Speed
Surface compound
Temperature
Temperature change rate
Thermal conductivity
Thermoelectric force
Torque
Volume

This parameter is used to set the dimensional unit in which the values are measured in the control. Different dimensional units are allocated to the categories listed above.



**Notice**

When the control is added to the operating page, the dimensional unit must be specified.

**9.20.1.8 Automatic mode visible**

Options:	deactivated
	activated

- Disabled:
  - The button for enabling the automatic mode is not available.
- Enabled:
  - The button for enabling the automatic mode is available.

The parameter can be used to set whether the button for enabling the automatic mode is to be available.

**9.20.1.9 Start Delay**

Options:	Setting option from 0.00:00:00 to 12:59:59 (hh:mm:ss)
----------	---

The parameter is used to set the time for a start delay of the fan.

**9.20.1.10      Overrun Delay**

Options:	Setting option from 0.00:00:00 to 12:59:59 (hh:mm:ss)
----------	---

The parameter is used to set the time for an overrun delay of the fan.

**9.20.1.11      Boost switch visible**

Options:	deactivated
	activated

- Disabled:
  - The button for enabling the boost mode is not displayed.
- Enabled:
  - The button for enabling the boost mode is displayed.

The parameter can be used to set whether the button for enabling the boost mode is to be displayed in the control.

**9.20.1.12      Boost value**

Options:	Setting option from -1.79769313486232E+308 to +1.79769313486232E+308
----------	--

The parameter is used to set the percentage fan speed level in boost mode.



**Notice**  
The parameter is only adjustable if the "Boost switch visible" parameter is set to "Enabled".

**9.20.1.13      Timeout for boost**

Options:	Setting option from 00:01:00 to 12:59:59 (hh:mm:ss)
----------	---

The parameter is used to set the duration of the boost mode.



**Notice**  
The parameter is only adjustable if the "Boost switch visible" parameter is set to "Enabled".



## 9.20.1.14 Show status value

Options:	deactivated
	activated

- Disabled:
  - The current status value is not displayed.
- Enabled:
  - The current status value is displayed.

This parameter is used to set whether the current status value is to be displayed.

## 9.20.1.15 Step size

Options:	Setting option from 1 to 100
----------	------------------------------

The parameter is used to set the smallest possible step size with which the control can be set. The step size can be set in percentage steps (min.: 0% - max. 100%).

## 9.20.1.16 Minimum value

Options:	Setting option from 0 to 100 (%)
----------	----------------------------------

The parameter is used to set the smallest adjustable brightness value. The brightness value can be set in percentage steps (min.: 0% - max. 100%).

## 9.20.1.17 Maximum value

Options:	Setting option from 0 to 100 (%)
----------	----------------------------------

The parameter is used to set the largest adjustable brightness value. The brightness value can be set in percentage steps (min.: 0% - max. 100%).

## 9.20.1.18 ON/OFF behaviour

Options:	On/Off using separate points
	On/Off linked to first stage
	No On/Off

- ON/OFF using separate points
  - The fan is switched directly on or off.
- On/Off linked to first stage
  - The fan can only be switched on and off via the first fan stage.
- No ON/OFF
  - The fan is not switched on or off manually. It is switched on and off automatically.

The parameter is used to specify how or via which fan stage the fan can be switched on and off.

## 9.20.1.19 Title information

Options:	<Title information>
----------	---------------------

With this parameter a custom text for the description of the information type displayed in the control can be specified. The length of the text is limited to 30 characters.



### Notice

The parameter is only adjustable if the "Enable information text" parameter is set to "Enabled".

## 9.20.1.20 Standard information text

Options:	<Standard information text>
----------	-----------------------------

This parameter can be used to specify a custom text for the standard information text. The length of the text is limited to 30 characters.



### Notice

The parameter is only adjustable if the "Enable information text" parameter is set to "Enabled".

## 9.20.1.21 Decimal places for information value

Options:	Setting option from 0 to 5
----------	----------------------------

This parameter can be used to set the number of decimal places that are displayed for numerical values in the information field.

The delay time can be set in steps of one millisecond (min.: 0 - max.: 5).



### Notice

The parameter is only adjustable if the "Enable information text" parameter is set to "Enabled".

### 9.20.2 Data points

#### 9.20.2.1 ON/OFF Command

An On or Off command is sent to the room temperature controller via the data point.

#### 9.20.2.2 ON/OFF Status

A status telegram for the room temperature controller is received via the data point.

#### 9.20.2.3 Current temperature

The temperature currently measured by the room temperature controller.

#### 9.20.2.4 Current temperature fault

The room temperature controller sends an error message via the data point when a valid temperature can no longer be determined due to a sensor failure.

#### 9.20.2.5 Normal operation mode command

A telegram is sent via the data point with which the operating mode of the room temperature controller can be changed.

#### 9.20.2.6 Command: Overwrite operation mode

A command is sent via the data point with which the operation mode `OPMODE_NORMAL` can be overwritten.

#### 9.20.2.7 HVAC status

The current status of the room temperature controller is received via the data point.

#### 9.20.2.8 Window contact

The status of a window contact is received via the data point.

#### 9.20.2.9 Presence detectors

Condensate alerts can be received via the data point.

#### 9.20.2.10 Information value

This data point is enabled when the "Enable information text" parameter is set to "Enabled".

A telegram with the value of the information text area of the control is received via the data point.

#### 9.20.2.11 Disable

The operating functions of the control are disabled via the data point.

#### 9.20.2.12 Fan speed command

This data point is used to enable any fan speed.

### **9.20.2.13 Status Fan speed**

This data point is used to receive a telegram with the status of the fan speed.

### **9.20.2.14 Automatic command**

The data point is enabled when parameter "Automatic mode visible" is set on "Enabled".  
Automatic mode can be "Enabled" or "Disabled" via the data point.

### **9.20.2.15 Status Automatic**

The data point is enabled when parameter "Automatic mode visible" is set on "Enabled".  
A status telegram is received via the data point, which supplies information about the automatic mode.

### **9.20.2.16 Boost command**

The data point is enabled when parameter "Boost switch visible" is set on "Enabled".  
The data point is used to send a command telegram with which the boost mode is started.

### **9.20.2.17 Boost status**

A status telegram is received via the data point with information as to whether the boost command is active.

### **9.20.2.18 Condensate alert**

An condensate alert is received via the communication object.

### **9.20.2.19 Temperature setpoint command**

The data point is enabled when the "Data point for the setpoint setting" parameter is set to "Absolute" or "Relative".  
The parameter is used to send command telegram with the temperature setpoint.

### **9.20.2.20 Temperature setpoint status**

The data point is enabled when the "Data point for the setpoint setting" parameter is set to "Absolute" or "Relative".  
A telegram with the adjusted temperature setpoint is received via the data point.

### **9.20.2.21 Temperature step command**

The data point is enabled when the "Data point for the setpoint settings" parameter is set to "Stepwise".  
A telegram for the stepwise adjustment of the temperature setpoint is sent via the data point.

### **9.20.2.22 Temperature step status**

The data point is enabled when the "Data point for the setpoint settings" parameter is set to "Stepwise".

A status telegram with the stepwise adjusted temperature setpoint is received via the data point.

### **9.20.2.23 Heating/Cooling command**

A command is sent via the data point with which a switchover between functions heating and cooling can take place.

**9.21 Control "RGBW"**

A control for corresponding lamps (LEDs, Philips Hue, etc.) can be set up via the "RGBW" control.

The allocation is made via the selected elements (group addresses). Specific settings can then be made for the lamps. For example, the colours can be changed or the warm-white component can be adjusted.



**Notice**

All adjustable parameters in the "General" tab are available in Chapter 9.1 "General parameters" on page 91.

**9.21.1 Parameters**

**9.21.1.1 Available colour channels**

Options:	RGB only
	RGB+Warm white/cold white
	RGB+White
	Warm white/cold white

- RGB only:
  - The light is composed of the colours from the RGB colour space.
- RGB+Warm white/cold white:
  - The light is composed of the colours from the RGB colour space as well as warm and cold white.
- RGB+White:
  - The light is composed of the colours from the RGB colour space as well as white light.
- Warm white/cold white:
  - The light is composed of warm and cold white.

The parameter is used to specify the colour channels that are to be supported by the control.

**9.21.1.2 Colour space**

Options:	HSV
	RGB

- HSV:
  - Colours are defined on the basis of the colour value, the colour saturation and the brightness.
- RGB:
  - Colours are defined on the basis of the colours red, green and blue.

The parameter is used to set colour space for the transmission of colours.

**9.21.1.3 Use predefined colours**

Options:	deactivated
	activated

- Disabled:
  - Predefined colours cannot be used.
- Enabled:
  - Predefined colours can be used.

The parameter is used to set whether predefined colours are to be available.

**9.21.1.4 Predefined colour x**

Options:	<Predefined colour x>
----------	-----------------------

A maximum of 5 colours that are available in the control in the IoT Dashboard can be predefined via the parameter.



**Notice**

The parameter is only adjustable if the "Use predefined colours" parameter was enabled.

**9.21.1.5 Colour channels**

Options:	Individual 3-byte channel
	Three 1-byte channels

The parameter is used to set the channels to be used for the transmission of colours.



**Notice**

The parameter is only adjustable if the "Available colour channels" parameter is set on "RGB only", "RGB+Warm white/cold white", "RGB+White", "Warm white/Cold white".

**9.21.1.6 Support master On/Off**

Options:	deactivated
	activated

- Disabled:
  - The data point is not enabled.
- Enabled:
  - The data point is enabled.

The parameter can be used to enable the 1-bit data points "Master switch command" and "Master switch status".



## 9.21.1.7 Support RGB On/Off

Options:	deactivated
	activated

- Disabled:
  - The data point is not enabled.
- Enabled:
  - The data point is enabled.

The parameter can be used to enable the 1-bit data points "RGB On/Off command" and "RGB On/Off status".

## 9.21.1.8 Support white On/Off

Options:	deactivated
	activated

- Disabled:
  - The data point is not enabled.
- Enabled:
  - The data point is enabled.

The parameter can be used to enable the 1-bit data points "White On/Off command" and "Whit On/Off status".

### 9.21.2 Data points

#### 9.21.2.1 Master switch command

This data point is enabled when the "Support master On/Off" parameter has been enabled.  
A 1-bit master switch command for switching on or off is sent via data point.

#### 9.21.2.2 Master switch status

This data point is enabled when the "Support master On/Off" parameter has been enabled.  
A 1-bit status telegram is received via the data point.

#### 9.21.2.3 RGB On/Off command

This data point is enabled when the "Support RGB On/Off" parameter has been enabled.  
A 1-bit telegram command for switching on or off is sent via data point.

#### 9.21.2.4 RGB On/Off status

This data point is enabled when the "Support RGB On/Off" parameter has been enabled.  
An RGB command is sent via data point.

#### 9.21.2.5 Red command

A telegram with the colour information of the red colour space is sent via the data point.

#### 9.21.2.6 Red status

A status telegram with the colour information of the red colour space is received via the data point.

#### 9.21.2.7 Green command

A telegram with the colour information of the green colour space is sent via the data point.

#### 9.21.2.8 Green status

A status telegram with the colour information of the green colour space is received via the data point.

#### 9.21.2.9 Blue command

A telegram with the colour information of the blue colour space is sent via the data point.

#### 9.21.2.10 Blue status

A status telegram with the current colour information of the blue colour space is received via the communication object.

#### 9.21.2.11 Hue command

A telegram with the colour value is sent via the data point.

### 9.21.2.12 Hue status

A status telegram with the current colour value is received via the data point.

### 9.21.2.13 Saturation command

A telegram with information for colour saturation is sent via the data point.

### 9.21.2.14 Saturation status

A telegram with information for colour saturation is received via the data point.

### 9.21.2.15 Command value

The current colour information is sent via the data point.

### 9.21.2.16 Status value

A status telegram with the current colour information is received via the data point.

### 9.21.2.17 LED RGB command

This data point is enabled when parameter "Available colour channels" is set on "RGB only", "White/cold white" or "RGB+white" and parameter "Colour space" on "RGB".

A telegram with the complete RGB information is sent via the data point.

### 9.21.2.18 LED RGB status

This data point is enabled when parameter "Available colour channels" is set on "RGB only", "White/cold white" or "RGB+white" and parameter "Colour space" on "RGB".

A status telegram with the complete RGB information is received via the data point.

### 9.21.2.19 LED HSV command

This data point is enabled when parameter "Available colour channels" is set on "RGB only", "White/cold white" or "RGB+white" and parameter "Colour space" on "HSV".

A telegram with the complete HSV information is sent via the data point.

### 9.21.2.20 LED HSV status

This data point is enabled when parameter "Available colour channels" is set on "RGB only", "White/cold white" or "RGB+white" and parameter "Colour space" on "HSV".

A status telegram with the complete HSV information is received via the data point.

### 9.21.2.21 White On/Off command

This data point is enabled when the "Support white On/Off" parameter has been enabled.

A telegram with the command for on or off from the white colour channel is sent via data point.

### 9.21.2.22 White On/Off status

This data point is enabled when the "Support white On/Off" parameter has been enabled.

A status telegram for on or off from the white colour channel is received.

### 9.21.2.23 LED warm white command

This data point is enabled when parameter "Available colour channels" is set on "RGB+warm white/cold white" or "Warm white/cold white".

A telegram with the value for white or warm white is sent via the data point.

### 9.21.2.24 LED warm white status

This communication object is enabled when parameter "Available colour channels" is set on "RGB+warm white/cold white" or "Warm white/cold white".

A status telegram with the value for white or warm white is received via the communication object.

### 9.21.2.25 LED cold white command

This data point is enabled when parameter "Available colour channels" is set on "RGB+warm white/cold white" or "Warm white/cold white".

A telegram with the value for cold white is sent via the data point.

### 9.21.2.26 LED cold white status

The data point is enabled when parameter "Available colour channels" is set on "RGB+warm white/cold white" or "Warm white/cold white".

A status telegram with the value for cold white is received via the data point.

### 9.21.2.27 LED white command

This data point is enabled when parameter "Available colour channels" is set on "RGB+white".

A telegram with the value for white is sent via the data point.

### 9.21.2.28 LED white status

This data point is enabled when parameter "Available colour channels" is set on "RGB+white".

A status telegram with the value for white is received via the data point.

### 9.21.2.29 Information value

This data point is enabled when the "Enable information text" parameter is set to "Enabled".

A telegram with the value of the information text area of the control is received via the data point.

### 9.21.2.30 Disable

The operating functions of the control are disabled via the data point.

**9.22 Control "Energy display"**

The summarised energy consumption within a certain timescale is displayed as diagram via the energy display control.



**Notice**  
All adjustable parameters in the "General" tab are available in Chapter 9.1 "General parameters" on page 91.

**9.22.1 Parameters**

**9.22.1.1 Number of external data**

Options:	Setting option from 0 to 4
----------	----------------------------

The parameter is used to set the number of the external data that are available in the control for energy display. Up to four external data can be specified.

**9.22.1.2 External x - Colour**

Options:	<External x - Colour>
----------	-----------------------

The parameter is used to specify the colour of the diagram with external data.



**Notice**  
The parameter is only adjustable if the "Number of external data" parameter has been set with a value of >2.

**9.22.1.3 Tile overview timescale**

Options:	Current day
	Current month
	Current week
	Last hour

- Current day:
  - The timescale depicts the current day.
- Current month:
  - The timescale depicts the current month.
- Current week
  - The timescale depicts the current week.
- Last hour:
  - The timescale depicts the last hour.

This parameter is used to set the time period the timescale is to depict on the control.

**9.22.1.4 Can export data**

Options:	deactivated
	activated

- Disabled:
  - Data for the use of energy cannot be output in a CSV file.
- Enabled:
  - Data for the use of energy can be output in a CSV file.

The parameter is used to set whether data for the use of energy by the user can be output in a CSV file.

**9.22.1.5 Display average values**

Options:	deactivated
	activated

- Disabled:
  - The average values of all energy types are not displayed on the control.
- Enabled:
  - The average values of all energy types are displayed on the control.

This parameter can be used to set whether the average values of all energy types are to be displayed on the control.

**9.22.1.6 Display min./max. values**

Options:	deactivated
	activated

- Disabled:
  - The minimum and maximum values of all energy types are not displayed on the control.
- Enabled:
  - The minimum and maximum values of all energy types are displayed on the control.

This parameter can be used to set whether the minimum and maximum values of all energy types are to be displayed on the control.

**9.23 Control "Physical meter"**

The "Physical meter" control serves for measuring the consumption of the physical size specified beforehand. It can only be positioned as function in the project tree.

**9.23.1 Parameters**

**9.23.1.1 Add <Physical meter>**

Options:	Electricity
	Gas
	Renewable energy
	Water

- Electricity:
  - Values for electricity are measured.
- Gas:
  - Values for gas are measured.
- Renewable energy:
  - Values for renewable energy are measured.
- Water:
  - Values for water are measured.

This parameter is used to set the physical size to be measured in the control.

**9.23.1.2 Category**

Options:	Electricity
	Gas
	Renewable energy
	Water

This parameter displays the previously specified physical size.

### 9.23.2 Data points

#### 9.23.2.1 Value

A telegram with the absolute value of the energy consumption is received via the data point.



**9.24 Control "Virtual meter"**

The "Virtual meter" control serves for measuring the consumption of the physical size specified beforehand. It can only be added as function in the project tree.

**9.24.1 Parameters**

**9.24.1.1 Add <Virtual meter>**

Options:	Electricity
	Gas
	Renewable energy
	Water

- Electricity:
  - Values for electricity are measured.
- Gas:
  - Values for gas are measured.
- Renewable energy:
  - Values for renewable energy are measured.
- Water:
  - Values for water are measured.

This parameter is used to set the physical size to be measured in the control.

**9.24.1.2 Category**

Options:	Electricity
	Gas
	Renewable energy
	Water

This parameter displays the previously specified physical size.

### 9.24.2 Data points

#### 9.24.2.1 Value

A telegram with the absolute value of the energy consumption is received via the data point.

**9.25 Control "Page links"**

Linking can be carried on one or several different websites via the "Page links" control.



**Notice**

All adjustable parameters in the "General" tab are available in Chapter 9.1 "General parameters" on page 91.

**9.25.1 Parameters**

**9.25.1.1 Representation in control**

Options:	Link text
	Link text and image
	Image

- Link text:
  - The link is displayed as link text.
- Link text and image:
  - The link is displayed as link text with image.
- Image:
  - The link is displayed as image.

The parameter is used to set how the link is to be displayed in the control.

**9.25.1.2 Number of web links**

Options:	Setting option from 1 to 100
----------	------------------------------

The parameter is used to specify the number of configurable web links. A maximum of 10 web links can be configured (min.: 1 - max.: 10).

**9.25.1.3 Address of external page x**

Options:	<Address of external page x>
----------	------------------------------

The parameter can be used to store the URL or IP addresses of the external websites to be linked.

**9.25.1.4 Behaviour of redirection**

Options:	Open as integrated page
	Open as superimposed window
	Open as new tab
	Open as new window

- Open as integrated page:
  - The link is opened as integrated page.
- As superimposed window:
  - The link is opened as superimposed window.
- Open as new tab:
  - The link is opened as new tab.
- Open as new window:
  - The link is opened as new window.

The parameter is used to used to configure the behaviour of the control when an outgoing link is clicked.

**9.25.1.5 Title information**

Options:	<Title information>
----------	---------------------

With this parameter a custom text for the description of the information type displayed in the control can be specified. The length of the text is limited to 30 characters.



**Notice**

The parameter is only adjustable if the "Enable information text" parameter is set to "Enabled".

**9.25.1.6 Standard information text**

Options:	<Standard information text>
----------	-----------------------------

This parameter can be used to specify a custom text for the standard information text. The length of the text is limited to 30 characters.



**Notice**

The parameter is only adjustable if the "Enable information text" parameter is set to "Enabled".

**9.25.1.7            Decimal places for information value**

Options:	Setting option from 0 to 5
----------	----------------------------

This parameter can be used to set the number of decimal places that are displayed for numerical values in the information field.

The delay time can be set in steps of one millisecond (min.: 0 - max.: 5).



**Notice**

The parameter is only adjustable if the "Enable information text" parameter is set to "Enabled".

**9.25.1.8            Display alias text**

Options:	deactivated
	activated

- Disabled:
  - No alias text is displayed instead of the URL or IP-address.
- Enabled:
  - An alias text is displayed instead of the URL or IP-address.

The parameter can be used to set that an alias text is to be displayed in place of the URL or IP address.

**9.25.1.9            Alias text of link x**

Options:	<Alias text of link x>
----------	------------------------

The parameter is used to specify the alias text that is to be displayed as link text instead of the URL or IP address.



**Notice**

The parameter is only adjustable if the "Display alias text" parameter is set to "Enabled".

**9.25.1.10 Image of link x**

Options:	Custom (if available)
	Lighting
	Communication
	Energy
	Function
	Multi-media
	Navigation
	Notification
	Object
	Location
	Scene
	System
	Temperature
	Window and door

- Custom (if available)
- Function
- Communication
- Energy
- Lighting
- Multi-media
- Navigation
- Notification
- Object
- Scene
- System
- Location
- Temperature
- Window and door

This parameter is used to select any symbol (or custom image) from the various listed categories in the symbols library. The symbol determines how the link is displayed in the button of the control.

## 9.25.1.11 Crop image

Options:	deactivated
	activated

- Disabled:
  - Selected images cannot be cropped.
- Enabled:
  - Selected images can be cropped.

This parameter can be used to enable the cropping function. All selected images are cropped via the cropping function so that they have the same height and width. If the cropping function has not been enabled, the dimension of the images is scaled anew so that they fit into the defined area.



### Notice

The parameter is only adjustable if in the "Representation in control" parameter the option "Link text and picture" or "Image" is set on "Enabled".

### **9.25.2 Data points**

#### **9.25.2.1 Information value**

This data point is enabled when the "Enable information text" parameter is set to "Enabled".

A telegram with the value of the information text area of the control is received via the data point.

#### **9.25.2.2 Disable**

The operating functions of the control are disabled via the data point.



**9.26 Control "Image"**

Linking can be carried on one or several different websites via the "Image" control via an image in the control in form of a symbol or a graph.



**Notice**

All adjustable parameters in the "General" tab are available in Chapter 9.1 "General parameters" on page 91.

**9.26.1 Parameters**

**9.26.1.1 Image**

Options:	Custom (if available)
	Lighting
	Communication
	Energy
	Function
	Multi-media
	Navigation
	Notification
	Object
	Location
	Scene
	System
	Temperature
Window and door	

- Custom (if available)
- Function
- Communication
- Energy
- Lighting
- Multi-media
- Navigation
- Notification
- Object
- Scene
- System
- Location
- Temperature
- Window and door

This parameter is used to select any symbol (or custom image) from the various listed categories in the symbols library. The symbol can also be an individually stored image file. It determines how the link is displayed in the button of the control.

**9.26.1.2 Crop image**

Options:	deactivated
	activated

- Disabled:
  - Selected images cannot be cropped.
- Enabled:
  - Selected images can be cropped.

This parameter can be used to enable the cropping function. All selected images are cropped via the cropping function so that they have the same height and width. If the cropping function has not been enabled, the dimension of the images is scaled anew so that they fit into the defined area.



**Notice**

The parameter is only adjustable if in the "Representation in control" parameter the option "Link text and picture" or "Image" is set on "Enabled".

**9.26.1.3 Address external page**

Options:	<Address external page>
----------	-------------------------

The parameter can be used to store the URL or IP addresses of the websites to be linked.

**9.26.1.4 Behaviour of redirection**

Options:	Open as integrated page
	Open as superimposed window
	Open as new tab
	Open as new window

- Open as integrated page:
  - The link is opened as integrated page.
- As superimposed window:
  - The link is opened as superimposed window.
- Open as new tab:
  - The link is opened as new tab.
- Open as new window:
  - The link is opened as new window.

The parameter is used to used to configure the behaviour of the control when an outgoing link is clicked.

## 9.27 Editing control elements

After the parameterisation of the controls, further editing can be carried out, e.g. a parameterised control can be copied to additionally use it on a different position of the same or another operating page.

### 9.27.1 Add control

Controls can be created either as a pure function or as function with associated tile.

#### Add control together with tile

1. Select a building part (e.g. a room or corridor).
2. Change into the "Paste" tab.
3. Select a control from the different categories.
4. Pull the control out of the selection area via drag and drop into the corresponding operating page.
  - The control is displayed as tile on the operating page; it appears also in the "Information" tab in right area of the screen.

#### Add function of the control

1. Select a building part (e.g. a room or corridor).
2. Change into the "Paste" tab.
3. Select a control from the different categories.
4. Pull the control out of the selection area via drag and drop into the "Information" tab in the right area of the screen.
  - The control is created in the "Information" area as a pure function. It does not appear on the operating page as tile.

### 9.27.2 Copy and position control

Controls can be copied and positioned in two different ways:



#### Notice

Controls can not only copied and pasted within a specific operating page, but also within other operating pages.

#### Copy function from the "Information" area

1. Mark the corresponding function in the "Information" tab in right area of the screen.
2. Open the selection list with a right click and select the "Copy" option, or, alternatively, press the "CTRL+C" button combination.
3. Select the "Paste" option with a right click, or, alternatively, press the "CTRL+V" button combination.
  - A copy of the function is added to the list. If a control is available, it will be added to the operating page as tile.

### **Copy control from the operating page**

1. Mark the control on the corresponding operating page that you want to copy.
2. To copy the control, press the CTRL+C button combination.
3. Select the operating page into which you want to paste the control.
4. Paste the control at the desired position with the CTRL+V button combination.
  - The control is added to the operating page.

### **Position control**

1. Position the control in the operating page via drag and drop or in the "Information" tab in the right area of the screen.
2. Adjust the size of the control by resting the mouse pointer in any corner of the control. If a square is displayed in the corner, you can pull the boundary of the control until you have set the desired size.

### **9.27.3 Delete control**

During the delete process it is differentiated whether the entire control including function is deleted, or only the tile is removed from the operating page and the function is retained.

#### **Delete tile and function**

1. Select the control you want to delete in the "Information" tab or on the operating page.
2. Open the selection list in the "Information" tab with a right click and click on the "Delete" option. Or, alternatively, press the "Del" button.
3. Confirm the request in the "Information" tab during deletion with "Yes". Or select the option "Remove tile(s) AND function(s)" and confirm the request with "Remove".

#### **Remove only tile**

If you want to retain the function in the "Information" tab when removing the tile, proceed as follows:

1. Select the corresponding tile on the operating page.
2. Press the Del button on your keyboard.
3. Select the option "Remove only tile(s)" and confirm the request with "Remove".

## 9.28 Configuration of applications and application pages

The applications with specified functions can be configured in the IoT Dashboard Tool. When these applications are enabled, they can be accessed via the application pages, or the application runs in the background. You can appropriately configure these applications beforehand.

### 9.28.1 "Scheduler" application

This application has an application page, via which schedulers can be set. This allows a holiday function to be set up and started, for example.

The general settings can be made via the IoT Dashboard Tool. A prerequisite is that the "Scheduler" application has been positioned beforehand in the "Information" tab.



#### Notice

The "Scheduler" application does not have an associated control and is only displayed in the "Information" tab.

#### 9.28.1.1 Scheduler configuration

##### Add scheduler

1. In the "Navigation" area, select the building part to which you want to add the scheduler.
2. Pull a scheduler from the "Paste" tab into the "Information" tab.
  - The scheduler is listed in the "Application" category.

##### Add scheduler functions

For the creation of the scheduler you need to first add all functions to the scheduler which you want to program. To do this, proceed as follows:

1. Select any scheduler under "Information".
  - The "Assignment" area opens below the "Tiles" area.
2. In the "Information" tab pull all the controls needed from the "Control" area into the "Assignment" tab via drag and drop.



#### Notice

A scheduler always relates to a building part. You can only add functions to the scheduler that have been configured for the respective building part.

## Add events

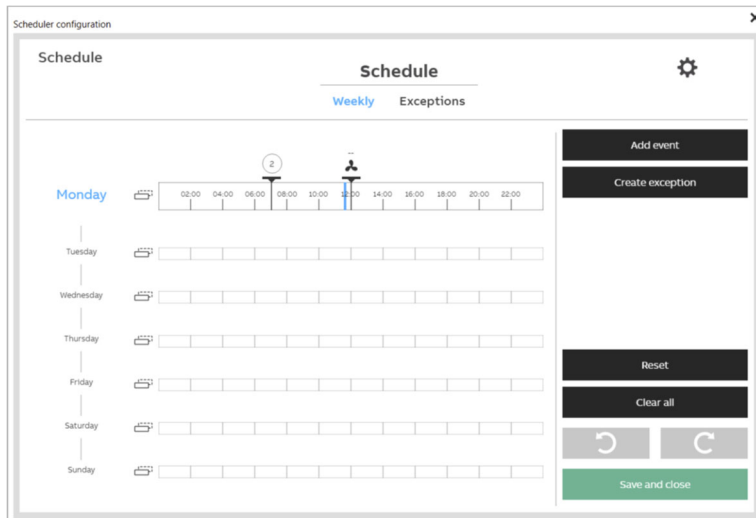

Fig. 31: Adding events

Events can be programmed within the scheduler configurations. The "Weekly" area is displayed as standard.

1. Select any scheduler in the "Information" tab.
2. Click on the black pin symbol.
  - The scheduler configurations of the "Weekly" area open.
3. Click on the "Add event" button.
  - A drop-down menu with all available functions opens.
4. Select a function and pull it via drag and drop to any position into any weekday.
5. Click once on the function symbol.
  - The function menu opens.
6. Change the time of the event. For this there are two options:
  - Move the event along on the timeline via drag and drop.
  - Click on the event and then on the arrow buttons to display the plus and minus keys. Adjust the time with a click on the plus and minus keys.
7. Click on the function symbol and then on the function name to adjust the values of the element

## Add exceptions

Fig. 32: Adding exceptions

When you have specified an event, you can add exceptions that deviate from the normal weekly scheduler.

1. Open the "Exceptions" area by either clicking on the "Add exceptions" button or on the headline of the "Exceptions" area.
  - You will be transferred to the menu of the exceptions settings.



### Notice

Once you have reached the "Exceptions" area via the "Add exceptions" button and have selected a weekday beforehand, the application creates an exception "Exception for x" automatically.

2. The procedure differs depending on how you created the exception.
  - When you have created an exception via the "Add exception" button, it will be displayed automatically as tile for the respective day with the designation "Exception for x". This exception you can edit.
  - If you have changed manually into the "Exceptions" area, you must create the exception via the "Add exception" button. It will then be displayed as tile with the designation "New exception". This exception you can edit.
3. Click on the button "Add exception" and pull a function into the timeline (configure the function as described under See "Add events" on page 246).
4. Assign a name under "Name of the exception".
5. Specify whether it is an exception for a single day or a sequence of days.
6. Specify the priority of the exception.
  - Priorities can be assigned in single steps from stage 2 (high), via stage 8 (standard) and up to stage 16 (low).
7. Define the timescale in which the exception takes place. For this, specify the day, month and the year.
8. Finally click on "Save and close".

### **Delete all events and exceptions**

1. Navigate to the scheduler configuration.
2. Change into the "Weekly" area or the "Exceptions" area.
3. Click on the "Delete all" button to delete either events (delete in "Weekly" area) or exceptions (delete in "Exceptions" area).

### **Undo settings**

1. Navigate to the scheduler configuration.
2. You can undo certain settings by switching exceptions forward or backward.
3. To do this, click on the forward or return arrow.

### **Specifying validity**

You can specify from when to when a time program is to be valid.

1. Click on the black gearwheel in the scheduler configuration at the top right.
2. Specify the starting and end date under "Active period". For this, specify the day in the month, or alternatively, the weekday, month and the year.



## 9.28.2 Parameters

### 9.28.2.1 Can be enabled/disabled

Options:	deactivated
	activated

- Disabled:
  - Disables the scheduler.
- Enabled:
  - Enables the scheduler.

The parameter can be used to enable or disable the respective scheduler.

### 9.28.2.2 Today can be overwritten

Options:	deactivated
	activated

- Disabled:
  - Today/tomorrow settings cannot be overwritten.
- Enabled:
  - Today/tomorrow settings can be overwritten.

This parameter is used to set whether today/tomorrow settings can be overwritten.

## 9.28.2.3 Show dependencies

Options:	deactivated
	activated

- Disabled:
  - Active times must not be overwritten.
- Enabled:
  - Active times can be overwritten.

When the parameter is enabled, schedulers in all buildings which relate to the scheduler can be overwritten.

## 9.28.2.4 Repetition

Options:	Always
	None
	On error

- Always:
  - The scheduler command is always repeated.
- None:
  - The scheduler command is not repeated.
- On error:
  - The scheduler command is only repeated in case of an error.

The parameter can be used to specify the repetition frequency of a scheduler command for active entries.

## 9.28.2.5 Restore status

Options:	deactivated
	activated

- Disabled:
  - The schedulers are not recalculated and sent to the bus at a reboot.
- Enabled:
  - The schedulers are recalculated and sent to the bus at a reboot.

This parameter can be used to specify the behaviour during the calculation and sending of schedulers in case of a reboot.

## 9.28.2.6 Exceptions available

Options:	deactivated
	activated

- Disabled:
  - Users cannot configure additional exceptions in the IoT Dashboard.
- Enabled:
  - Users can configure additional exceptions in the IoT Dashboard.

The parameter is used to specify whether users can configure additional exceptions in the IoT Dashboard.

## 9.28.2.7 Today available

Options:	deactivated
	activated

- Disabled:
  - Today/tomorrow settings are not displayed in the IoT Dashboard .
- Enabled:
  - Today/tomorrow settings are displayed in the IoT Dashboard .

This parameter is used to specify whether today/tomorrow settings are displayed in the IoT Dashboard .

### 9.28.3 Application "Alarms"

Alarms and associated trigger conditions can be defined for each available control.

The definable alarms depend on the type of the control (e.g. dimmer, blind, etc.). The different alarms and their configurations are described in the following.

#### 9.28.3.1 Overview of alarms

The left column in the following table provides an overview of all data points with configurable alarms. The right column lists the controls for which the data points are listed under the alarms.

Name of the alarm	Control
<b>Scene command</b>	Control "Local scene" Control "Remote Scene"
<b>Disable</b>	Control "Local scene" Control "Remote Scene" Control "Sequence" Control "Dimmer preset values" Control "Dimmer value slider" Control "Dimmer stepwise" Control "Fan preset values" Control "Fan speed slider" Control "Switch" Control "Blind button" Control "Blind slider" Control "Value for slider" Control "DALI light" Control "DALI emergency light" Control "RGBW" Control "RTC"
<b>Brightness command</b>	Control "Dimmer preset values" Control "Dimmer value slider" Control "Dimmer stepwise" Control "DALI light" Control "DALI emergency light"
<b>Brightness status</b>	Control "Dimmer preset values" Control "Dimmer value slider" Control "Dimmer stepwise" Control "DALI light" Control "DALI emergency light"
<b>Switch command</b>	Control "Dimmer value slider" Control "Dimmer stepwise" Control "Blind slider" Control "Switch" Control "DALI light" Control "DALI emergency light"
<b>Switching status</b>	Control "Dimmer value slider" Control "Dimmer stepwise" Control "Blind slider" Control "Switch" Control "DALI light" Control "DALI emergency light"
<b>Lamp/ballast fault</b>	Control "DALI light"

<b>Start/Stop command</b>	Control "Dimmer stepwise"
<b>Relative dimming command</b>	Control "Dimmer stepwise"
<b>Fan speed command</b>	Control "Fan preset values" Control "Fan speed slider" Control "RTC"
<b>Status Fan speed</b>	Control "Fan speed preset values" Control "Fan speed slider" Control "RTC"
<b>ON/OFF command</b>	Control "Fan speed preset values" Control "Fan speed slider" Control "RTC"
<b>ON/OFF status</b>	Control "Fan speed preset values" Control "Fan speed slider" Control "RTC"
<b>Automatic command</b>	Control "Fan speed preset values" Control "Fan speed slider" Control "RTC"
<b>Status Automatic</b>	Control "Fan speed preset values" Control "Fan speed slider" Control "RTC"
<b>Stop top/bottom</b>	Control "Blind button"
<b>Move up/down</b>	Control "Blind button"
<b>Stop/slat alignment</b>	Control "Blind button"
<b>Status height</b>	Control "Blind button" Control "Blind slider"
<b>Wind alarm</b>	Control "Blind button" Control "Blind slider"
<b>Status upper end position</b>	Control "Blind slider"
<b>Status lower end position</b>	Control "Blind slider"
<b>Move to pos. height</b>	Control "Blind slider"
<b>Move slats</b>	Control "Blind slider"
<b>Status slat</b>	Control "Blind slider"
<b>Command value</b>	Control "Value for slider"
<b>Status value</b>	Control "Value for slider" Control "Gauge"
<b>Sunrise time</b>	Control "Weather"
<b>Sunset time</b>	Control "Weather"
<b>General sensor failure</b>	Control "Weather"
<b>Twilight sensor disrupted</b>	Control "Weather"
<b>Temperature value</b>	Control "Weather"
<b>Felt temperature value</b>	Control "Weather"
<b>Wind speed</b>	Control "Weather"

<b>Wind sensor disrupted</b>	Control "Weather"
<b>Relative humidity</b>	Control "Weather"
<b>Brightness value</b>	Control "Weather"
<b>Brightness sensor disrupted</b>	Control "Weather"
<b>Rain/Sun</b>	Control "Weather"
<b>Day/Night</b>	Control "Weather"
<b>Day/night sensor disrupted</b>	Control "Weather"
<b>Air pressure value</b>	Control "Weather"
<b>Fault during time synchronisation</b>	Control "Weather"
<b>GPS longitude</b>	Control "Weather"
<b>GPS latitude</b>	Control "Weather"
<b>Master switch command</b>	Control "RGBW"
<b>Master switch status</b>	Control "RGBW"
<b>RGB On/Off command</b>	Control "RGBW"
<b>RGB On/Off status</b>	Control "RGBW"
<b>LED RGB command</b>	Control "RGBW"
<b>LED RGB status</b>	Control "RGBW"
<b>White On/Off command</b>	Control "RGBW"
<b>White On/Off status</b>	Control "RGBW"
<b>LED warm white command</b>	Control "RGBW"
<b>LED warm white status</b>	Control "RGBW"
<b>LED white command</b>	Control "RGBW"
<b>LED white status</b>	Control "RGBW"
<b>LED cold white command</b>	Control "RGBW"
<b>LED cold white status</b>	Control "RGBW"
<b>Current temperature</b>	Control "RTC"
<b>Current temperature fault</b>	Control "RTC"
<b>Normal operation mode command</b>	Control "RTC"
<b>Overwrite operation mode command</b>	Control "RTC"
<b>HVAC status</b>	Control "RTC"
<b>Boost command</b>	Control "RTC"
<b>Overwrite command</b>	Control "RTC"
<b>Overwrite status</b>	Control "RTC"
<b>Window contact</b>	Control "RTC"

<b>Presence detectors</b>	Control "RTC"
<b>Current status</b>	Control "RTC"
<b>Condensate alert</b>	Control "RTC"
<b>Temperature step command</b>	Control "RTC"
<b>Temperature stepwise status</b>	Control "RTC"
<b>Heating/Cooling command</b>	Control "RTC"
<b>Temperature setpoint command</b>	Control "RTC"
<b>Temperature setpoint status</b>	Control "RTC"
<b>Test result</b>	Control "DALI emergency light"
<b>Converter status</b>	Control "DALI emergency light"
<b>Lamp fault</b>	Control "DALI emergency light"
<b>Converter failure</b>	Control "DALI emergency light"
<b>Lamp aging</b>	Control "DALI emergency light"

### 9.28.3.2 Alarm options

The data points for which alarms can be configured depends on the associated control and the set parameters. The scope of available options for the creation of alarms can therefore vary.

The available types of alarms and their functions is explained in the following.

Alarm type	Function
Add "Different" alarm	The alarm is created for a scenario in which the signalled value or status (e.g. brightness value of the dimmer, status of the dimmer) deviates from the specifications.
Add "Equals" alarm	The alarm is created for a scenario in which the signalled value or status (e.g. brightness value of the dimmer, status of the dimmer) corresponds to the specifications.
Add "Field bus" alarm	The alarm is created for a scenario in which the value or status measured on the bus (e.g. brightness value of the dimmer, status of the dimmer) is to be signalled.
Add "Low" alarm	The alarm is created for a scenario in which the signalled value or status (e.g. brightness value of the dimmer, status of the dimmer) has reached a threshold specified as "Low".
Add "Very low" alarm	The alarm is created for a scenario in which the signalled value or status (e.g. brightness value of the dimmer, status of the dimmer) has reached a threshold specified as "Very low".
Add "High" alarm	The alarm is created for a scenario in which the signalled value or status (e.g. brightness value of the dimmer, status of the dimmer) has reached a threshold specified as "High".
Add "Very high" alarm	The alarm is created for a scenario in which the signalled value or status (e.g. brightness value of the dimmer, status of the dimmer) has reached a threshold specified as "Very high".
Add "Within the band"	The alarm is created for a scenario in which the signalled value or status (e.g. brightness value of the dimmer, status of the dimmer) exceeds a specified limit value.
Add "Out of band" alarm	The alarm is created for a scenario in which the signalled value or status (e.g. brightness value of the dimmer, status of the dimmer) deviates from the specified value.



### 9.28.3.3 Alarm configuration

Alarms are configured individually for each control in the "Alarms" tab below the operating pages. To allow alarms to be configured, controls must have been added beforehand to the operating page.

Fig. 33: Alarms configuration

To configure one or several alarms, proceed as follows:

1. Select the control for which you want to configure alarms.
  - As soon as you have selected a control for which alarms can be configured, the "Alarms" tab is displayed in the area below the operating page.
2. Change into the "Alarms" tab.
  - All available data points for which alarms can be configured are displayed on the left side.
3. Select a data point for which you want to configure an alarm.
4. Right-click on the data point and select the option "Add alarms".
  - A list opens with the alarm types that can be configured for the data point.
5. Select an alarm type.
6. Next, under "Alarm name" and "Description", specify an alarm name and a description for the alarm.
7. Then specify the desired trigger conditions for the alarm.
8. Set a tick in "Request acknowledgement" if the alarms are to be acknowledged.
9. Set a tick in "Notification" when a notification is to be sent when the alarm is triggered.



#### Notice

There are controls for which no alarms can be configured. That is why no details are provided for these controls at this point.

### 9.28.4 Application "Local scene"

The "Local scene" application has no application page. Local scenes are started via the "Local scene" control.



**Notice**

The parameterisation is described in the Chapter 9.2 "Control "Local scene"" on page 96.

#### 9.28.4.1 Scene actuator configuration

Individual actions can be grouped into one action in local scenes. All actions grouped in one scene are started simultaneously. This enables the user, for example, to create certain lighting scenes with just one press of the button (= several dimming actions).

Display name	Source	Function	Point
Dimmer presets.Brightness control value	✕ <input type="checkbox"/> Myself	Dimmer presets	Brightness control value
Fan speed presets.Automatic command	✕ <input type="checkbox"/> Myself	Fan speed presets	Automatic command
Fan speed presets.Fan speed command	✕ <input type="checkbox"/> Myself	Fan speed presets	Fan speed command
Shutter slider.Move to pos. height	✕ <input type="checkbox"/> Myself	Shutter slider	Move to pos. height

Fig. 34: Adding events



**Notice**

Each local scene can be copied with all its defined settings. Create a copy of the scene control or of the function in the "Information" tab to copy the application together with all its settings.

## Creating and editing scenes

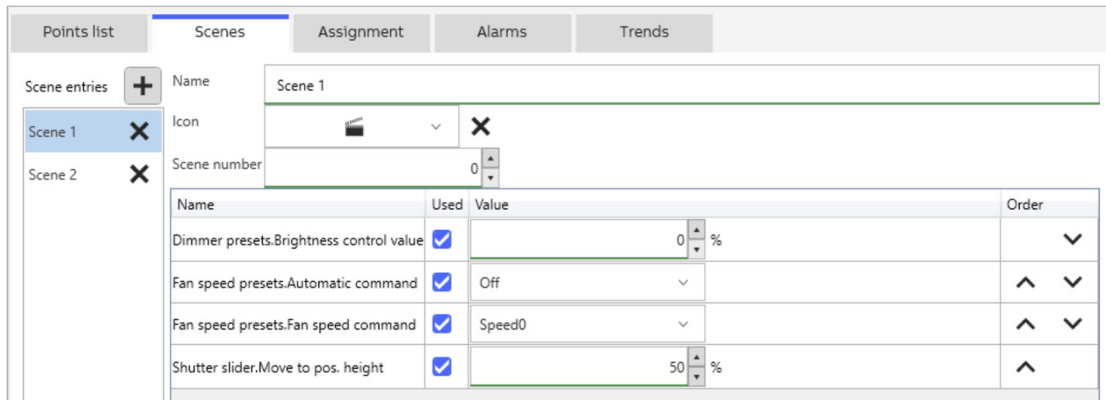

Fig. 35: Adding events

1. Select the "Local scene" control or, alternatively, the "Local scene" application in the "Information" tab for which you want to configure one or several scenes.
2. Open the "Points list" tab below the operating page.
3. Change in parallel into the "Information" tab or "Project" in the right area of the screen.
4. Pull all controls that are to execute a function in the scene into the "Points list" tab via drag and drop.
  - Depending on the scope of functions of the control, a menu opens in which you must select the function to be programmed.
5. When you have added all controls or functions to the points list, you change into the "Scenes" tab.
6. Click on the plus symbol next to "Scene entries" to specify the number of scene entries in the scene control.
  - The functions you have added beforehand are displayed each time you select a scene.
  - In the list you can change between the different scene entries.
7. Then assign a scene name for each scene under "Name"
8. Specify a scene symbol for each scene under "Symbol".
9. Specify a scene number (0 to 64) for each scene under "Scene number".
  - You can later link a scene control with the scene via the scene number.
10. Set a tick under "Used" for each function if you want to use it in your scene.
11. Use "Value" to select the function that is to be executed (e.g. dimming to 50%, or move the blind up).
12. Use the arrow buttons to change the "Order" of execution of the functions within the scene.

### **Delete scene completely**

1. Select the "Local scene" control or, alternatively, the "Local scene" application for which you want to delete scenes.
2. Change to the "Points list" tab below the operating page.
3. In the list under "Scene entries", click on the scene entry to be deleted.
4. Delete the scene entry with a click on the X symbol.
  - The scene entry is deleted immediately from the list.

### **Delete functions from scene**

1. Select the "Local scene" control or, alternatively, the "Local scene" application for which you want to delete scenes.
2. Change to the "Points list" tab below the operating page.
3. Click on the X symbol under "Display name".
  - The function is deleted immediately from the list.

### 9.28.5 Application "Sequence"

The application has no application page. Sequences are a special form of scene. Sequences are started via the "Sequence" control.



**Notice**

The parameterisation is described in the Chapter 9.3 "Control "Sequence"" on page 99.

#### 9.28.5.1 Sequence configuration

The grouped actions in a sequence are not all played at the same time as in scene, but in a predefined order. Time intervals between two action call-ups can be defined freely.

Display name	Source	Function	Point
Dimmer presets.Brightness contro	✗ [ ] Myself	💡 Dimmer presets	Brightness control value
Fan speed presets.Automatic com	✗ [ ] Myself	🌀 Fan speed presets	Automatic command

Fig. 36: Sequence points list

### Creating and editing a sequence

Name	Used	Value	Order	Delay before (HH:MM:SS)
Dimmer presets.Brightness control value	<input checked="" type="checkbox"/>	25 %	▼	00:00:01
Fan speed presets.Automatic command	<input checked="" type="checkbox"/>	Off	▲	00:00:01

Fig. 37: Creating and editing a sequence

1. Select the "Sequence" control for which you want to configure a sequence.
2. Open the "Points list" tab below the operating page.
3. Change in parallel into the "Information" tab or "Project" in the right area of the screen.
4. Pull all controls that are to execute a function in the sequence into the "Points list" tab via drag and drop
  - Depending on the scope of functions of the control, a menu opens in which you must select the function to be programmed.
5. When you have added all controls or functions to the points list, you change into the "Values" tab.
  - Here the functions you have added beforehand are listed.

6. Set a tick under "Used" for each function if you want to use it in your sequence.
7. Use "Value" to select the function that is to be executed (e.g. dimming to 50%, or move the blind up).
8. Use the arrow buttons to change the "Order" of execution of the functions within the sequence.
9. Under "Delay" you can specify the delay with which a function is to be played in the sequence.

### **Delete functions from sequence**

1. Select the "Sequence" control in which you want to delete one or several functions.
2. Change to the "Points list" tab below the operating page.
3. Click on the X symbol under "Display name".
  - The function is deleted immediately from the list.

### **Copy functions from sequence**

1. Select the "Sequence" control in which you want to copy one or several functions.
2. Change to the "Values" tab below the operating page.
3. Mark a function.
4. Click on the small square next to the "Used" column or press CTRL+C on your keyboard.
5. Paste the copied function with a right-click and click on "Copy" or press the CTRL+V button combination.

### 9.28.6 Application "Trends"

The "Trends" tab is available below the operating page for each selected control. If trends can be collected for a control, the respective functions are displayed in the "Trends" tab. Collected trends can be displayed in the "Trend viewer" control.

Which trends can be raised depends on the type of the selected control (e.g. dimmer, blind, etc.). The different trend settings and their configurations are described in the following.

#### 9.28.6.1 Overview of trends

The left column in the following table provides an overview of all data points with configurable trends. The right column lists the controls for which the data point is listed under the trends.

Name of the trend	Control
<b>Scene command</b>	Control "Local scene" Control "Remote Scene"
<b>Disable</b>	Control "Local scene" Control "Remote Scene" Control "Sequence" Control "Dimmer preset values" Control "Dimmer value slider" Control "Stepwise dimmer" Control "Fan speed preset values" Control "Fan speed slider" Control "Blind button" Control "Blind slider" Control "Button" Control "Value for slider" Control "RGBW" Control "RTC" Control "DALI light" Control "DALI emergency light"
<b>Play</b>	Control "Sequence"
<b>Stop</b>	Control "Sequence"
<b>Pause</b>	Control "Sequence"
<b>Restart</b>	Control "Sequence"
<b>Brightness command</b>	Control "Dimmer preset values" Control "Dimmer value slider" Control "Stepwise dimmer" Control "DALI light" Control "Button"
<b>Brightness status</b>	Control "Dimmer preset values" Control "Dimmer value slider" Control "Stepwise dimmer" Control "DALI light" Control "Button"
<b>Switch command</b>	Control "Dimmer value slider" Control "Stepwise dimmer" Control "Button" Control "DALI light"
<b>Switching status</b>	Control "Dimmer value slider" Control "Stepwise dimmer"

	Control "Button" Control "DALI light"
<b>Relative dimming command</b>	Control "Stepwise dimmer"
<b>Start/Stop command</b>	Control "Stepwise dimmer"
<b>Lamp/ballast fault</b>	Control "DALI light"
<b>Fan speed command</b>	Control "Fan speed preset values" Control "Fan speed slider" Control "RTC"
<b>Status Fan speed</b>	Control "Fan speed preset values" Control "Fan speed slider" Control "RTC"
<b>ON/OFF command</b>	Control "Fan speed preset values" Control "Fan speed slider" Control "RTC"
<b>ON/OFF status</b>	Control "Fan speed preset values" Control "Fan speed slider" Control "RTC"
<b>Automatic command</b>	Control "Fan speed preset values" Control "Fan speed slider" Control "RTC"
<b>Status Automatic</b>	Control "Fan speed preset values" Control "Fan speed slider" Control "RTC"
<b>Move up/down</b>	Control "Blind button"
<b>Stop top/bottom</b>	Control "Blind button"
<b>Stop/slat adjustment</b>	Control "Blind button"
<b>Status height</b>	Control "Blind button" Control "Blind slider"
<b>Wind alarm</b>	Control "Blind button" Control "Blind slider"
<b>Status upper end position</b>	Control "Blind slider"
<b>Status lower end position</b>	Control "Blind slider"
<b>Move to pos. height</b>	Control "Blind slider"
<b>Move slats</b>	Control "Blind slider"
<b>Status slat</b>	Control "Blind slider"
<b>Command value</b>	Control "Value for slider"
<b>Status value</b>	Control "Gauge" Control "RGBW" Control "Value for slider"
<b>Sunrise time</b>	Control "Weather"
<b>Sunset time</b>	Control "Weather"
<b>General sensor failure</b>	Control "Weather"
<b>Twilight sensor disrupted</b>	Control "Weather"



<b>Temperature value</b>	Control "Weather"
<b>Felt temperature value</b>	Control "Weather"
<b>Wind speed</b>	Control "Weather"
<b>Wind sensor disrupted</b>	Control "Weather"
<b>Relative humidity</b>	Control "Weather"
<b>Brightness value</b>	Control "Weather"
<b>Brightness sensor disrupted</b>	Control "Weather"
<b>Rain/Sun</b>	Control "Weather"
<b>Day/Night</b>	Control "Weather"
<b>Day/night sensor disrupted</b>	Control "Weather"
<b>Air pressure value</b>	Control "Weather"
<b>Fault during time synchronisation</b>	Control "Weather"
<b>GPS longitude</b>	Control "Weather"
<b>GPS latitude</b>	Control "Weather"
<b>Master switch command</b>	Control "RGBW"
<b>Master switch status</b>	Control "RGBW"
<b>RGB On/Off command</b>	Control "RGBW"
<b>RGB On/Off status</b>	Control "RGBW"
<b>LED RGB command</b>	Control "RGBW"
<b>LED RGB status</b>	Control "RGBW"
<b>White On/Off command</b>	Control "RGBW"
<b>White On/Off status</b>	Control "RGBW"
<b>LED warm white command</b>	Control "RGBW"
<b>LED warm white status</b>	Control "RGBW"
<b>LED white command</b>	Control "RGBW"
<b>LED white status</b>	Control "RGBW"
<b>LED cold white command</b>	Control "RGBW"
<b>LED cold white status</b>	Control "RGBW"
<b>Current temperature</b>	Control "RTC"
<b>Current temperature fault</b>	Control "RTC"
<b>Normal operation mode command</b>	Control "RTC"
<b>Overwrite operation mode command</b>	Control "RTC"
<b>Overwrite command</b>	Control "RTC"
<b>Overwrite status</b>	Control "RTC"

<b>Window contact</b>	Control "RTC"
<b>Presence detectors</b>	Control "RTC"
<b>Current status</b>	Control "RTC"
<b>Condensate alert</b>	Control "RTC"
<b>Temperature step command</b>	Control "RTC"
<b>Temperature stepwise status</b>	Control "RTC"
<b>Heating/Cooling command</b>	Control "RTC"
<b>Temperature setpoint command</b>	Control "RTC"
<b>Temperature setpoint status</b>	Control "RTC"
<b>Test result</b>	Control "DALI emergency light"
<b>Converter status</b>	Control "DALI emergency light"
<b>Lamp fault</b>	Control "DALI emergency light"
<b>Converter failure</b>	Control "DALI emergency light"
<b>Lamp aging</b>	Control "DALI emergency light"

### 9.28.6.2 Trends configuration

Trends are configured for each selected control in the "Trends" tab below the operating pages. To allow trend data to be saved, controls must have been added beforehand to the operating page.

Which trends can be configured depends on the type and parameterisation of the selected control. Depending on the parameterisation, not all data points are enabled and not all trends can therefore be configured.

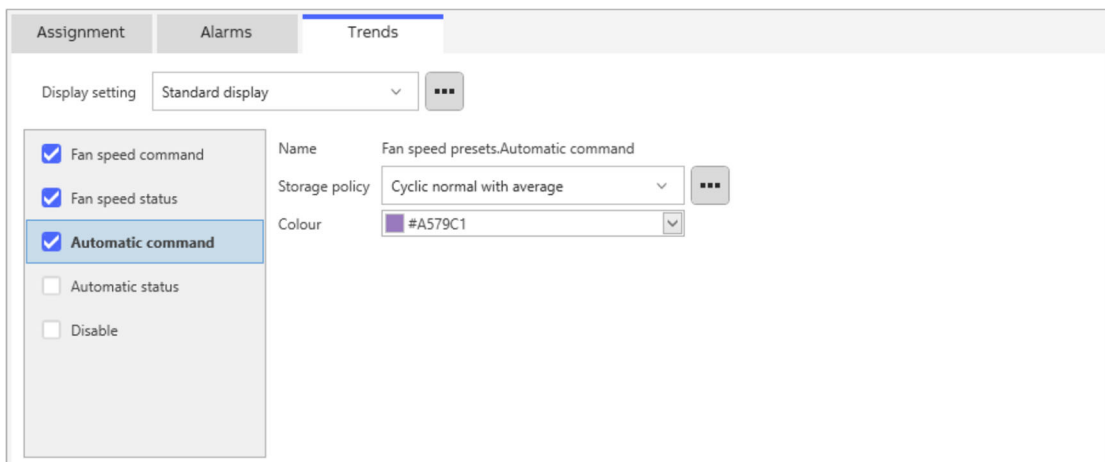

Fig. 38: Adding events

#### Configuring trends

1. Select the control for which you want to configure trends.
2. Select the "Trends" tab below the operating page.
  - All enabled data points for which trends can be saved are displayed in a list on the left side.
3. Select a data point for which you want to raise trend data.
4. Set a tick in the left area for each data point for which you want to record trend data.
  - A menu opens in the right area for each selected data point via which the recording of trend data can be configured more precisely.
5. Specify the storage settings. For this, select the desired storage setting (see chapter "Trends - Storage policies" on page 58).
6. Specify the colour in which the determined value is to be displayed later in the trend viewer control.



#### Notice

Depending on the type of control to which the data point belongs, also the "Dead band" option can be configured apart from the general storage settings. This defines the number of operations that are not to be stored in the trend data.

## Linking trends with "Trend viewer" control

1. Select the corresponding "Trend viewer" control that you want to link with the trends.
2. Open the "Points list" tab below the operating page.
3. Change into the "Information" tab or "Project" in right area of the screen.
4. Pull all controls whose trend data are to be displayed in the trend viewer into the "Points list" via drag and drop.
  - If you have configured several trends for a control, a menu opens from which you can select all data points whose trend data are to be raised (multiple selection possible by holding CTRL).
5. Set a tick for option "On tile?" if the determined values are to be displayed within the "Trend viewer" control.
6. Set a tick for option "In application?" if the determined values are also to be displayed within the application.

Trends are configured for each selected control in the "Trends" tab below the operating pages. To allow trend data to be saved, controls must have been added beforehand to the operating page.

Which trends can be configured depends on the type and parameterisation of the selected control. Depending on the parameterisation, not all data points are enabled and not all trends can therefore be configured.

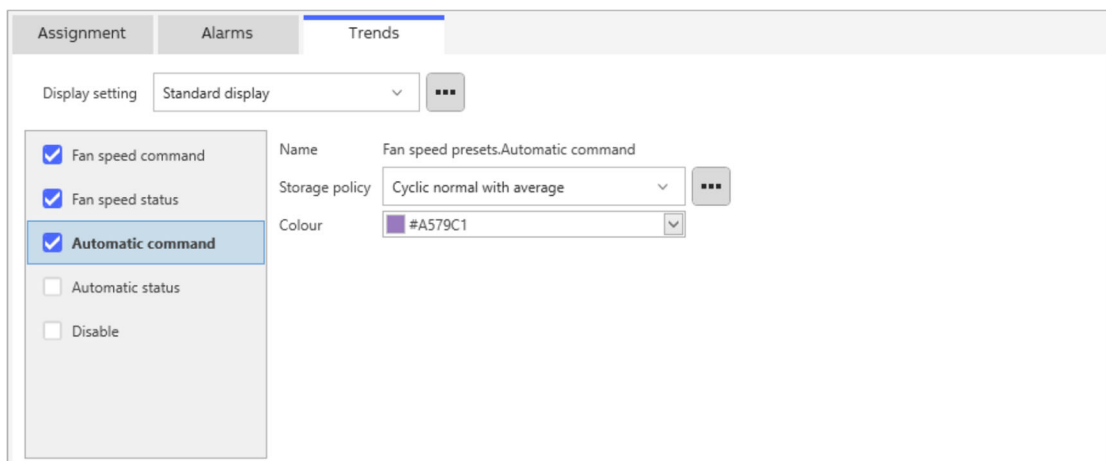

Fig. 39: Adding events

### 9.29 Editing of data points

Assigned data points can be seen in two different views.

- All data points enabled for a control are displayed in the "Assignment" tab, if the control has been marked beforehand.
- All data points that have been enabled for a room (or a different building part), for example, are displayed in the "Assignment" tab next to the "Tiles" tab.

To which data points of a control the group addresses can be assigned to depends on the parameterisation. Different parameters enable different data points. You can edit data points directly in the IoT Dashboard Tool or alternatively via the ETS.



**Notice**

Detailed expert knowledge for understanding by means of KNX training is assumed, especially with regard to the commissioning software ETS.

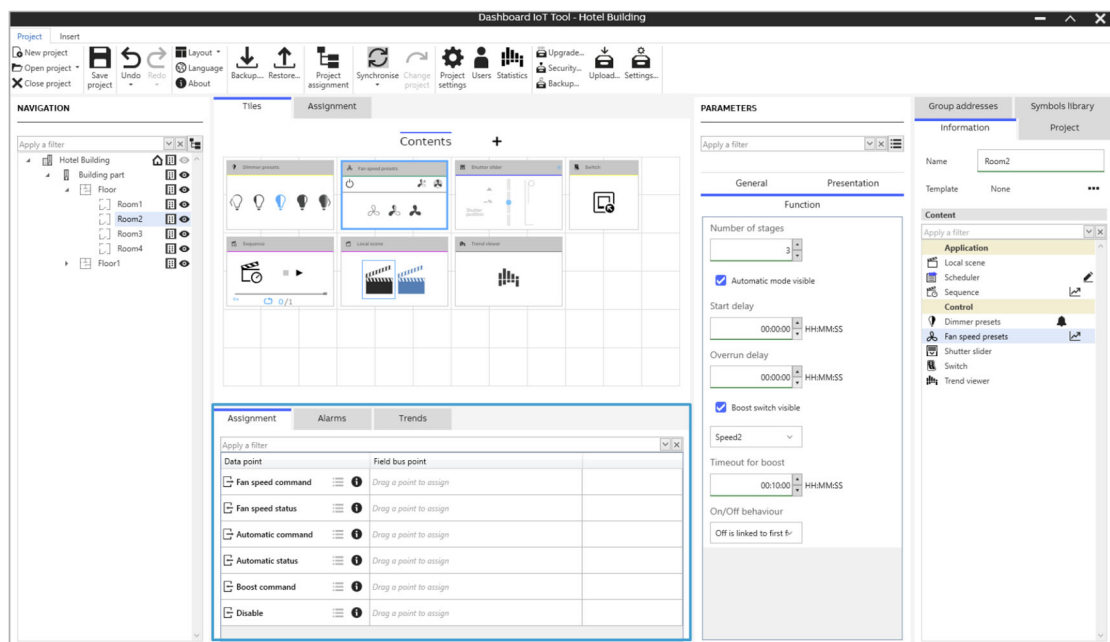

Fig. 40: Data points area

To establish the connection between a control and a sequence, for example, you must assign a group address to the control directly in the IoT Dashboard Tool or, alternatively, in the ETS. For this purpose, each control has several data points (see chapter "Data points" in the descriptions of the control further up above).



**Notice**

Basic information for operation and the views of the IoT Dashboard Tool is available in the context-sensitive online Help of the application. This can be opened via the corresponding Help symbols.

### 9.30 Editing group addresses

Group addresses are created and managed in the "Group addresses" tab in the right area of the screen.



#### Notice

Detailed expert knowledge for understanding by means of KNX training is assumed, especially with regard to the commissioning software ETS.

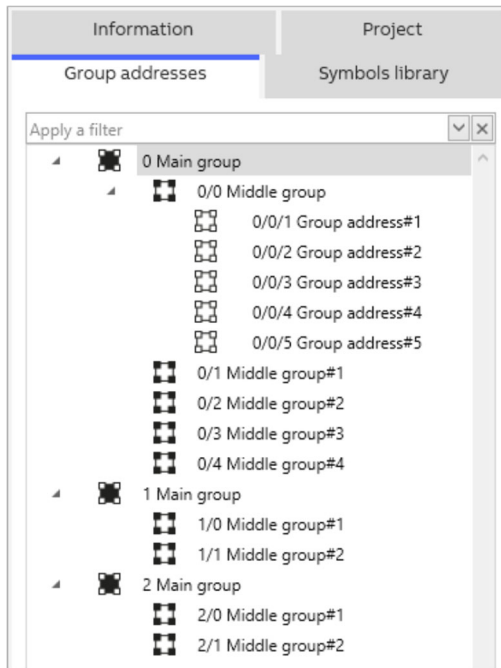

Fig. 41: "Group addresses" area

The group address of the elements is used for the functional allocation:

- The sending group contains the group address to which a telegram is to be sent. A maximum of one sending group address can be used per element.
- The status groups include one or several group addresses to display the status of a component. The sending group address is often also a status group.
- The value includes the value that is to be sent or the value to which the IoT Dashboard Server is to respond.

### 9.30.1 Main groups

#### Add main groups

1. Open the "Group addresses" tab in the right area of the screen.
2. Make a right click in the tab and click on option "Add main groups".
  - The "Add main groups" menu opens.
3. Assign a meaningful name under "Name".
4. Specify the number of necessary main groups under "Count".
  - You can add a maximum of 30 main groups.
5. Under "Generate addresses", specify how main groups are to be generated during adding. For this, the following three options are available:
  - Fill up (use first free)
    - The new main groups are added free.
  - Append
    - The new main groups are appended to existing main groups.
  - Start with
    - The new main groups are numbered from any number.
6. Enable one of the two checkboxes if required and enter a time interval.
  - "Continuous reading process":
    - Values are continuously requested in the interval of the specified value.
  - "Force reading process if no value was received:"
    - If no values are received within the specified interval, a reading process is enforced.
7. Click on "Add".
  - The main groups are added to the "Group addresses" tab.

#### Add middle groups

1. Open the "Group addresses" tab in the right area of the screen.
2. Make a right click on the main group and click on option "Add middle groups".
  - The "Add middle groups" menu opens.
3. Proceed as described from Point 3 under See "Add main groups" on page 271 .

#### Edit main groups/middle groups

1. Open the "Group addresses" tab in the right area of the screen.
2. Make a right click on any main group/middle group and click on option "Edit".
  - You have the following options in the menu window:
    - Under "Name" you can change the name of the main group/middle group.
    - Under "Address" you can change the address of the main group/middle group.
3. Click in any area to close the menu window.

### **Rename main groups/middle groups**

1. Open the "Group addresses" tab in the right area of the screen.
2. Make a right click on any main group/middle group and click on option "Rename".
  - A menu window opens.
3. Assign any name
4. Click in any area to close the menu window.

### **Copy main groups/middle groups**

1. Open the "Group addresses" tab in the right area of the screen.
2. Make a right click on any main group/middle group and click on option "Copy", or alternatively, perform the "CTRL+C" button combination.
3. Make a right click in the empty area. The following options are available:
  - Paste:
    - The main group/middle group is pasted as exact copy.
  - Special paste:
    - The address of the main group/middle group can be adjusted before pasting.

### **Delete main groups/middle groups**

1. Open the "Group addresses" tab in the right area of the screen.
2. Make a right click on any main group/middle group and click on option "Delete", or alternatively, click on the main group/middle group and press the "Del" button.
  - The main group/middle group is deleted immediately.

### **Filter main groups/middle groups**

1. Open the "Group addresses" tab in the right area of the screen.
2. Click in the search bar in the top area of the tab.
3. Filter for any main or middle group via a key term (e.g. light).
  - The filtered results are displayed below the search bar.



## 9.30.2 Group addresses

### Add group addresses

Fig. 42: Adding events

1. Open the "Group addresses" tab in the right area of the screen.
2. Select any main group.
3. Make a right click on the main group and click on option "Add group addresses".
  - The "Group addresses" menu opens.
4. Assign a meaningful name under "Name".
5. Specify the number of necessary group addresses.
  - You can add a maximum of 2050 group addresses.
6. Under "Generate addresses", specify how group addresses are to be generated during adding. For this, the following three options are available:
  - Fill up (use first free)
    - The new group addresses are added free.
  - Append
    - The new group addresses are appended to existing group addresses.
  - Start with
    - The new group addresses are numbered from any number.
7. Specify the data type of the group address(es).
8. Enable one of the two checkboxes if required and enter a time interval.
  - "Continuous reading process":
    - Values are continuously requested in the interval of the specified value.
  - "Force reading process if no value was received:":
    - If no values are received within the specified interval, a reading process is enforced.
9. Click on "Add".
  - The group addresses are added to the "Group addresses" tab.

### Edit group addresses

1. Open the "Group addresses" tab in the right area of the screen.
2. Make a right click on any group address and click on option "Edit", or click on the pin symbol.
  - In the menu that opens, you can adjust the settings of the group addresses.
3. Click in any area to close the menu window.

### Rename group addresses

1. Open the "Group addresses" tab in the right area of the screen.
2. Make a right click on any group address and click on option "Rename".
  - A menu window opens.
3. Assign any name
4. Click in any area to close the menu window.

### Copy group addresses

1. Open the "Group addresses" tab in the right area of the screen.
2. Make a right click on any group addresses and click on option "Copy", or alternatively, perform the "CTRL+C" button combination.
3. Select a main group under which you want to paste the group address.
4. Make a right click on the main group and click on option "Paste", or alternatively, perform the "CTRL+V" button combination.
  - The group addresses are pasted.

### Delete group addresses

1. Open the "Group addresses" tab in the right area of the screen.
2. Make a right click on any group address and click on option "Delete", or alternatively, click on the group address and press the "Del" button.
  - The group address is deleted immediately.



#### Notice

If a group address has already been assigned, a message is displayed during deletion. You are requested to either continue or abort the deletion process.

### Filter group addresses

1. Open the "Group addresses" tab in the right area of the screen.
2. Click in the search bar in the top area of the tab.
3. Filter for any group address via a key term.
  - The filtered results are displayed below the search bar.

### 9.31 General assignment

Group addresses are assigned to the data points of the control via the "Assignment" function. Data points can only send telegrams to or receive telegrams from the KNX bus after the assignment.

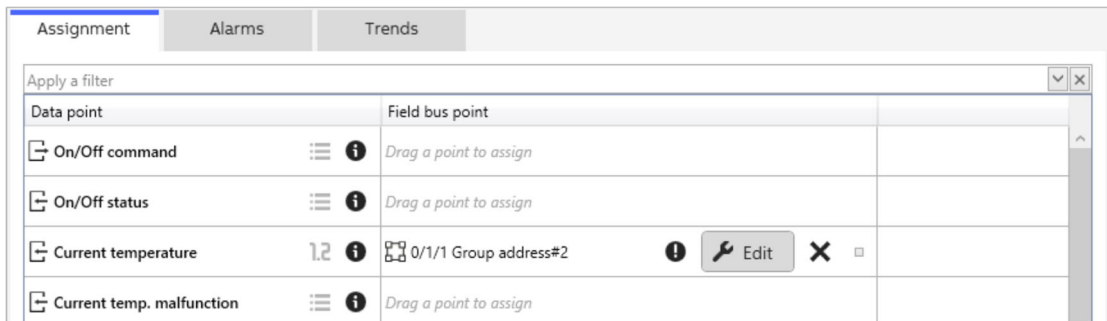

Fig. 43: Assignments

You can configure assignments in three different areas:

- Assignment of an individual control or function block
- Assignment of all functions of a building architectural element (e.g. a room)
- Assignment of all functions of all building architectural elements in the project (Project assignment)

### Data types

To allow you to assign a group address to a data point, the native data type of the data point and the group address must match. Data types are displayed via a symbol on the right next to their respective data point.

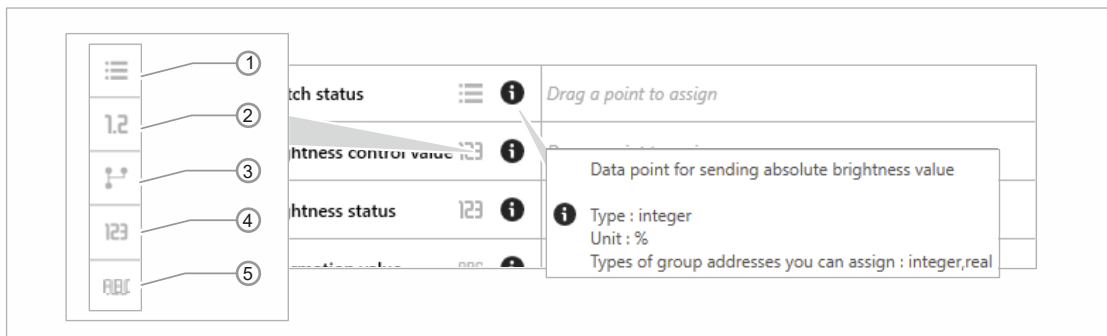

Fig. 44: Data types

- [1] Enumeration
- [2] Real (floating decimal point)
- [3] Structure (Struktur)
- [4] Integer
- [5] String (Text)



#### Notice

Keep the mouse pointer on the information symbol of a data point to display the data type, the unit and assignable data types.

### 9.31.1 Converter

#### Converter

The program supports converters when group addresses are assigned to data points that do not correspond to their native data type or their unit. A converter gives you the option to also combine data points and group addresses of different types. If, for example, a group address is assigned to a data point, the software recognises the data type of the group address and creates a converter independent of this type and displays the result (e.g. value for On, value for Off).



#### Notice

Please note that conversion is not possible for all data types.

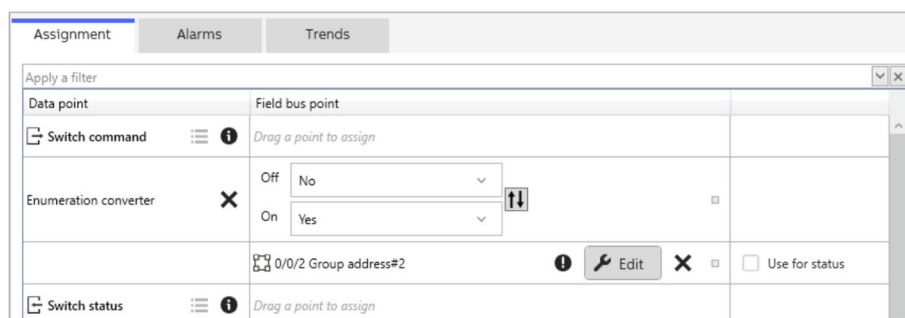

Fig. 45: Converter

#### Conversion on data type level

For conversion on data type level there are three possible scenarios:

- 1 No converter required since the data types of data point and group address are compatible (e.g. data type real to data type real).
- 2 Converter without adjustable parameters
  - In this case, for example, a numerical dimming value is converted by the converter without you having to make a parameter setting.
- 3 Converter with adjustable parameters
  - In this case, for example, the data type Real is converted into data type String and you have to make a parameter setting.
  - You can use the same converter repeatedly for the same data point.



#### Notice

In case of scenario 1 and 2, the converters are not displayed in the IoT Dashboard Tool. In case of scenario 3, the converter is displayed in the IoT Dashboard Tool.

#### Conversion on unit level

Conversions can be made also on the level of the unit of a group address or a data point. The unit of a native data point or a group address can, for example, be percent. The assignment checks the software as to whether the units are compatible with each other. If yes, the conversion is carried out automatically by the software. An assignment is not possible if the units are not compatible.

## 9.31.2 Assignment of an individual control

How to perform the assignment for an individual control is described in the following.

1. Select any building architectural element in the navigation tree.
2. Then, in the tiles view, click on the control whose assignment you want to make.
3. Open the "Assignment" tab below the tiles.
  - All data points of the control are displayed in the assignment tab.
4. Open the "Group addresses" tab parallel in the right area of the screen.
5. Select a group address.
6. Pull the group address via drag and drop onto any data point in the "Assignment" tab.
  - The software recognises the data type of the data point and, if necessary, creates the correct converter. If no converter is found, the software checks whether the group address is compatible with the data point also without converter.



### Notice

If the data type of the group address and the data point do not match and no suitable converter is available, the group address cannot be assigned. In case of an invalid assignment, the data point hanging on the mouse pointer receives a red background colour in the IoT Dashboard Tool.



### Notice

You can add a second group address to an existing converter. Pull the group address into the area of the existing converter. Then both group addresses are displayed in the tab within the same converter.

7. Make the needed settings when the converter can be parameterised.

### Force the use of a new converter

You can assign a new group address to the data point and use a new converter. This function you can use, for example, when you want to add a new group address that has the same data type as a group address that has already been assigned and also use a converter with different settings.

Example: You are assigning a scene group address to a switch and configure the converter so that the scene is set on 10. If you want to assign a different scene group address whose converter sets the scene on 20, you require an additional converter with different settings.

The use of a new converter you enforce as follows:

1. During the assignment via drag and drop, keep the CTRL button pressed.

### Using the same converter for command and status telegrams

Normally different data points are used for command and status telegrams. For a switch, for example, a command data point and a status data point is available. Both use the type On or Off.

When you want to use the same group address for command and status, you normally need to do the assignment twice. To simplify the process you can proceed as follows:

1. Enable the checkbox "Use for status" or "Use for command" for the respective data point.



### Notice

If the data point of the group address is not supported, the checkbox is not visible.

### **View and edit assigned group address details**

1. Click on the "Edit" button at a data point with an assigned group address.
  - The group address settings are opened.
2. Make the necessary settings.

### **Delete assigned group addresses**

If you want to delete a group address that has been assigned to a data point, proceed as follows:

1. Select the group address to be deleted in the assignment window.
2. Click on the X symbol or press the Del button.
  - The group address is deleted.

### **Delete assigned group addresses from the converter**

If you want to delete a group address from a converter, proceed as follows:

1. Select the converter whose assigned group address you want to delete.
2. Open the converter menu with a right click on the square on the right next to the converter.
3. Select the option "Delete points".
  - The group address is deleted from the converter.

### **Delete converter**

1. Select the converter you want to delete.
2. Open the converter menu with a right click on the square on the right next to the converter.
3. Select the option "Delete" or press the Del button.
  - The converter is deleted.

### **Copy and paste group addresses**

1. Select a group address you want to copy.
2. Open the group addresses menu with a right click on the square next to the group address.
3. Select the option "Copy". Or, alternatively, copy via the CTRL+C button combination.
4. Select a data point or a converter for which you want to paste the group address.
5. Make a right click and paste the group address via the option "Paste" or the "CTRL+V" button combination.

### Copy and paste converter

1. Select a converter you want to copy.
2. Open the converter menu with a right click on the square on the right next to the converter.
3. Select the option "Copy". Or, alternatively, copy via the CTRL+C button combination.
4. Select a data point for which you want to paste the converter.
5. Make a right click and paste the converter via the option "Paste" or the "CTRL+V" button combination.



#### Notice

You also have the option to copy and paste group addresses and converters simultaneously.



#### Notice

If a group address has already been assigned to a data point and is copied, the group address cannot be pasted.

### Filter

You can filter for data points, group addresses and converters via the filter menu above the "Assignment" tab.

1. Enter a key term in the search line and select a predefined filter value.
  - All relevant results are displayed.

### 9.31.3 Assignment of all functions of a building architectural element

You can also configure the assignment on the level of an entire building architectural element. The difference to the assignment of an individual control is that all controls of a building architectural element are displayed. You can also view the data points of each control together with the assigned group addresses.

How you can configure the assignment of all controls of a building architectural element is described in the following:

1. Select any building architectural element in the navigation tree.
2. Open the "Assignment" tab above the tiles.
  - All controls with associated data points are displayed in the "Assignment" tab.
3. Open the "Group addresses" tab parallel in the right area of the screen.
4. Select a group address.
5. Pull the group address via drag and drop onto any data point in the "Assignment" tab.
  - The software recognises the data type of the data point and, if necessary, creates the correct converter. If no converter is found, the software checks whether the group address is compatible with the data point also without converter.



#### Notice

If the data type of the group address and the data point do not match and no suitable converter is available, the group address cannot be assigned. In case of an invalid assignment, the data point hanging on the mouse pointer receives a red background colour in the IoT Dashboard Tool.



#### Notice

You can add a second group address to an existing converter. Pull the group address into the area of the existing converter. Then both group addresses are displayed in the tab within the same converter.

6. Make the needed settings when the converter can be parameterised.

#### Force the use of a new converter

You can assign a new group address to the data point and use a new converter. This function you can use, for example, when you want to add a new group address that has the same data type as a group address that has already been assigned and also use a converter with different settings.

Example: You are assigning a scene group address to a switch and configure the converter so that the scene is set on 10. If you want to assign a different scene group address whose converter sets the scene on 20, you require an additional converter with different settings.

The use of a new converter you enforce as follows:

1. During the assignment via drag and drop, keep the CTRL button pressed.



### Using the same converter for command and status telegrams

Normally different data points are used for command and status telegrams. For a switch, for example, a command data point and a status data point is available. Both use the type On or Off.

When you want to use the same group address for command and status, you normally need to do the assignment twice. To simplify the process you can proceed as follows:

1. Enable the checkbox "Use for status" or "Use for command" for the respective data point.



#### Notice

If the data point of the group address is not supported, the checkbox is not visible.

### View and edit assigned group address details

1. Click on the "Edit" button at a data point with an assigned group address.
  - The group address settings are opened.
2. Make the necessary settings.

### Delete assigned group addresses

If you want to delete a group address that has been assigned to a data point, proceed as follows:

1. Select the group address to be deleted.
2. Click on the X symbol or press the Del button.
  - The group address is deleted.

### Delete assigned group addresses from the converter

If you want to delete a group address from a converter, proceed as follows:

1. Select the converter whose assigned group address you want to delete.
2. Open the converter menu with a right click on the square on the right next to the converter.
3. Select the option "Delete points".
  - The group address is deleted from the converter.

### Delete converter

1. Select the converter you want to delete.
2. Open the converter menu with a right click on the square on the right next to the converter.
3. Select the option "Delete" or press the Del button.
  - The converter is deleted.

### Copy and paste group addresses

1. Select a group address you want to copy.
2. Open the group addresses menu with a right click on the square next to the group address.
3. Select the option "Copy". Or, alternatively, copy via the CTRL+C button combination.
4. Select a data point or a converter for which you want to paste the group address.
5. Make a right click and paste the group address via the option "Paste" or the "CTRL+V" button combination.

### Copy and paste converter

1. Select a converter you want to copy.
2. Open the converter menu with a right click on the square on the right next to the converter.
3. Select the option "Copy". Or, alternatively, copy via the CTRL+C button combination.
4. Select a data point for which you want to paste the converter.
5. Make a right click and paste the converter via the option "Paste" or the "CTRL+V" button combination.



#### Notice

You also have the option to copy and paste group addresses and converters simultaneously.



#### Notice

If a group address has already been assigned to a data point and is copied, the group address cannot be pasted.

### Filter

You can filter for controls, data points and group addresses via the filter menu above the "Assignment" tab.

1. Enter a key term in the search line and select a predefined filter value.
  - All relevant results are displayed.



#### Notice

Filters function according to the following rules:

- When a filter applies to a control, a data point or a group address, all contents of the control or data points are displayed.
- When a filter applies to a converter, all contents of the converter are displayed.
- When a subordinate element is filtered, for example, also the overriding elements are displayed.

### 9.31.4 Project assignment

You can also configure the assignment on the project level. The difference to the assignment of an individual control or the assignment of all building architectural elements is that all controls of the entire project are displayed. You can also view the data points of each control together with the assigned group addresses.



#### Notice

In the "Project assignment" menu you cannot view or edit converters.

How you can configure the assignment on the project level is described in the following:

1. Open the "Project" tab.
2. Click on the "Project assignment" button to open the project assignment.
3. Use the navigation tree to locate a building architectural element or a control within the assignment menu.
4. If you select an entry in the navigation tree, it will be opened in the project assignment.
5. Open the "Group addresses" tab parallel in the right area of the screen.
6. Select a group address.
7. Pull the group address via drag and drop onto any data point in the "Assignment" tab.



#### Notice

If the data type of the group address and the data point do not match and no suitable converter is available, the group address cannot be assigned. In case of an invalid assignment, the data point hanging on the mouse pointer receives a red background colour in the IoT Dashboard Tool.



#### Notice

If a filter is active in the navigation tree, building architectural elements are not displayed and cannot be displayed in the project assignment.

#### View and edit assigned group address details

1. Click on the "Edit" button at a data point with an assigned group address.
  - The group address settings are opened.
2. Make the necessary settings.

#### Delete assigned group addresses

If you want to delete a group address that has been assigned to a data point, proceed as follows:

1. Select the group address to be deleted in the assignment window.
2. Click on the X symbol or press the Del button.
  - The group address is deleted.

### Copy and paste group addresses

1. Select a group address you want to copy.
2. Open the group addresses menu with a right click on the square next to the group address.
3. Select the option "Copy". Or, alternatively, copy via the CTRL+C button combination.
4. Select a data point or a converter for which you want to paste the group address.
5. Make a right click and paste the group address via the option "Paste" or the "CTRL+V" button combination.



#### Notice

If a group address has already been assigned to a data point and is copied, the group address cannot be pasted.

### Filter

You can filter for building architectural elements, data points and group addresses via the filter menu above the project assignment.

1. Enter a key term in the search line and select a predefined filter value.
  - All relevant results are displayed.



#### Notice

Filters function according to the following rules:

- If a filter applies to a building architectural element (e.g. a room), a control or a data point, all contents of the element or control are displayed.
- When a subordinate element is filtered, for example, also the overriding elements are displayed.

### 9.32 Importing the configuration into the ABB i-bus® KNX IoT Dashboard Server

When the building structure has been created and the necessary parameters configured, the project configuration can be imported into the IoT Dashboard Server. Proceed as described in the following:

1. Open the "Upload..." option in the "Project" tab.
  - The upload dialog opens.
2. Enter the IP address under "Address" under which the IoT Dashboard Server can be reached.
3. Set a tick under "Overwrite data during upload" if all existing data on the IoT Dashboard Server are to be overwritten.
  - If you do not want to overwrite all data during the upload, select all options to be overwritten under "Options" (See "Upload options" on page 285) manually.
4. Enter the upload password under "Upload password".
  - Or you can change the existing password under "Change password..."
5. Enable the "Save" option if the specified password is to be always stored in the dialogue window.
6. Click on the "Upload" button to upload the configuration into the IoT Dashboard Server.



**Notice**

Connected devices can be searched for under "Found IoT Dashboard Server" and a click on "Scan". Also the IP address can be determined in this way.

#### Upload options

Option	Explanation
Delete alarm history	During the upload all alarms are deleted from the history.
Delete scheduler programming	During the upload all scheduler programs are deleted.
Delete trend data	During the upload all trend data are deleted.
Delete users	During the upload all existing users are deleted.
Delete user settings	During the upload all custom settings are deleted.

Table 9: Upload options

### 9.33 RESET (Resetting the device)

Three different reset procedures are available, which are described in the following:

#### Resetting the device

1. Press the Reset button longer than 2 seconds but less than 10 seconds.
  - The LED ON flashes green (3 Hz).
  - The LAN/Link LED lights up yellow.
  - The KNX telegram LED lights up yellow.

#### Resetting the IP address (DHCP)

1. Press the Reset button longer than 10 seconds but less than 20 seconds.
  - The LED ON flashes green (3 Hz).
  - The LAN/Link LED flashes yellow (3 Hz)
  - The KNX telegram LED lights up yellow.

#### Reset to factory settings

1. Press the Reset button longer than 20 seconds but less than 30 seconds.
  - The LED ON flashes green (3 Hz).
  - The LAN/Link LED flashes yellow (10 Hz).
  - The KNX telegram LED flashes yellow (10 Hz).
  - At a press of less than 2 seconds or more than 30 seconds there is no effect and the LEDs light up permanent.

## 10 Operation via ABB i-bus® KNX IoT Dashboard

The operation of the building automation takes place following the upload of the configuration into the IoT Dashboard Server via the Web-based IoT Dashboard (see chapter 8.5.10 “Uploading a project“ on page 43).

### 10.1 General control and display functions

After the successful upload of the configuration from the IoT Dashboard Tool into the IoT Dashboard, the automation can be controlled by the user in the IoT Dashboard .

For this you must log yourself in via a browser with your account and the corresponding password.

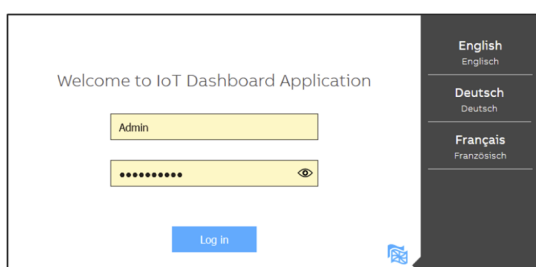

Fig. 46: Login screen

#### Change language

Before the login you have the option of changing the language of the IoT Dashboard . Proceed as follows:

2. Click on the flag symbol at the bottom right in the screen.
3. Use a click to select one of the listed languages.
  - The login screen is reloaded and the selected language is displayed.

#### Login

You log yourself into the IoT Dashboard as follows:

1. Enter the IP address of the IoT Dashboard in the search line of your browser.
  - You reach the login screen of the IoT Dashboard.
2. Enter your user name and enter your password.
3. Click on "Login".

After the successful login you can use the IoT Dashboard for executing functions. The IoT Dashboard is subdivided into several areas from which the building automation can be operated.

The various functions of these areas are described in the following.

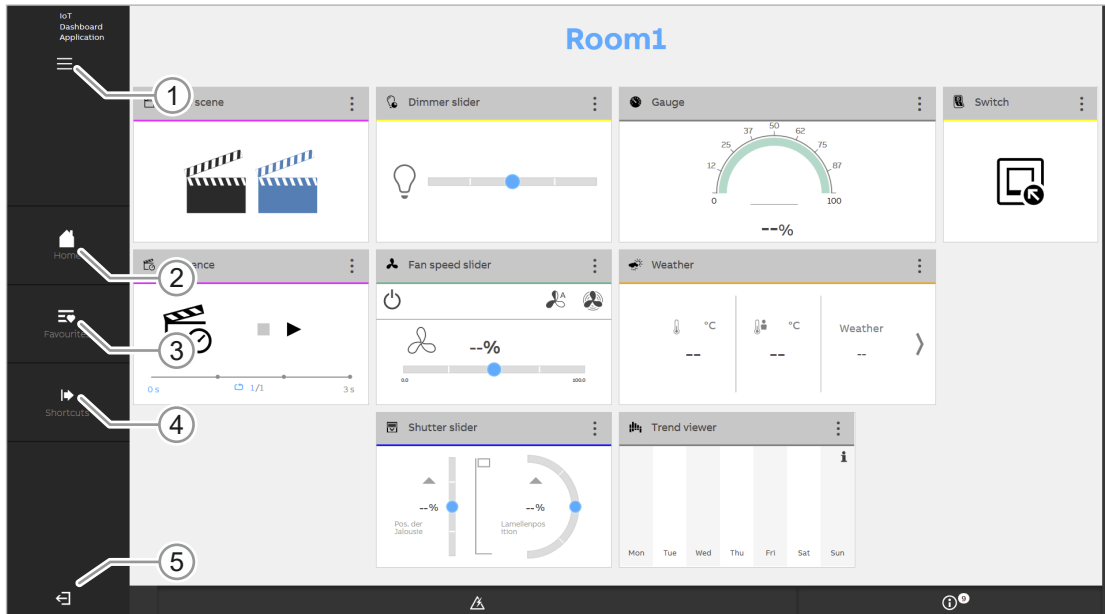

Fig. 47: Overview of IoT Dashboard

- [1] Burger menu for opening the ribbon bar
- [2] Quick access: Homepage
- [3] Quick access: Favourites
- [4] Quick access: Links
- [5] User logout

Pos.	Description of functions
[1]	Opening the ribbon bar to access the building architecture and all other functions of the IoT Dashboard.
[2]	Quick access to the homepage specified beforehand in the building architecture in the IoT Dashboard Tool.
[3]	Quick access to the favourite controls of the different operating pages.
[4]	Quick access to custom links to different operating pages of the IoT Dashboard.
[5]	Exiting the IoT Dashboard.



## Ribbon bar

Different functions are grouped in the ribbon bar. Open the ribbon bar to access these functions. Open the ribbon bar as follows:

1. Click on the Burger menu to open the ribbon bar.

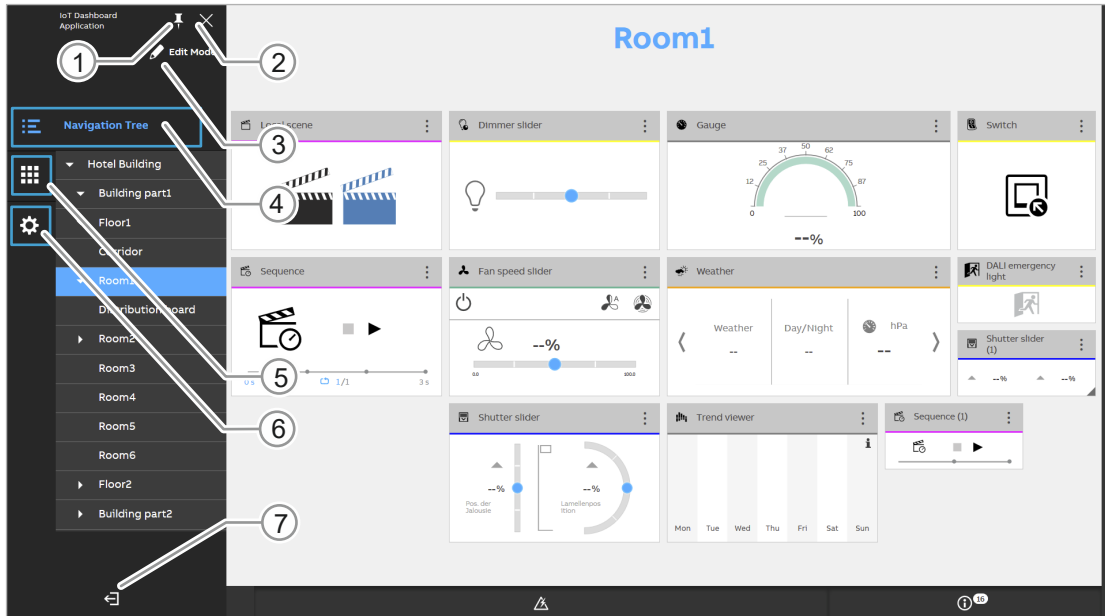

Fig. 48: Ribbon bar

- [1] Fix the ribbon bar
- [2] Close the ribbon bar
- [3] Edit mode
- [4] Navigation tree
- [5] Applications
- [6] Settings
- [7] Logout

Pos.	Description of functions
[1]	Fix the folded-out ribbon bar at the left edge of the screen.
[2]	Close the folded-out ribbon bar
[3]	Editing of controls in the operating pages.
[4]	Access to the navigation tree with the building architecture.
[5]	Access to available applications.
[6]	Access to the settings for the IoT Dashboard.
[7]	Exiting the IoT Dashboard.

## Navigation tree

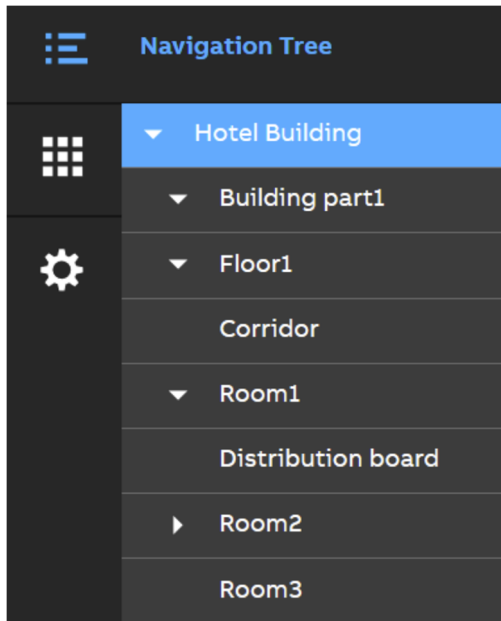

Fig. 49: Navigation tree

In the navigation tree you can navigate through the different sections of the building architecture which were configured beforehand in the IoT Dashboard Tool. In addition, you can adjust the navigation tree according to your requirements.

### Open elements

If the mouse pointer is moved across the navigation tree and the elements of the building architecture, they receive a blue background. Individual menu items, for example, can be folded out to display floors, rooms and staircases.

1. Move the mouse pointer to any element.
2. Click on the arrow symbol in the element to fold out a menu item.
  - The subordinate elements are folded out.

## Applications

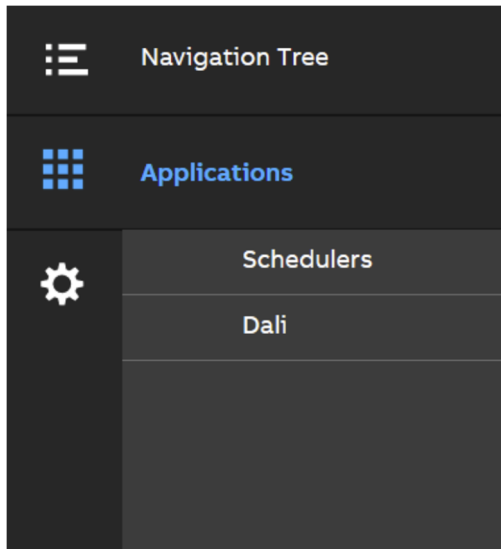

Fig. 50: "Applications" menu

The "Applications" menu can be used to navigate through the different applications.

### Open applications

1. Click in the ribbon bar on the "Applications" option.
2. Select any application.
  - The application is opened in the right area of the screen.

## 10.2 Controls

Controls are used to fulfil the basic functions such as "Switching", "Dimming", "Blinds", "Scenes" and "RTC", as well as additional functions. The controls can contain switches, buttons, sliders and displays.

### 10.2.1 Basic structures of controls

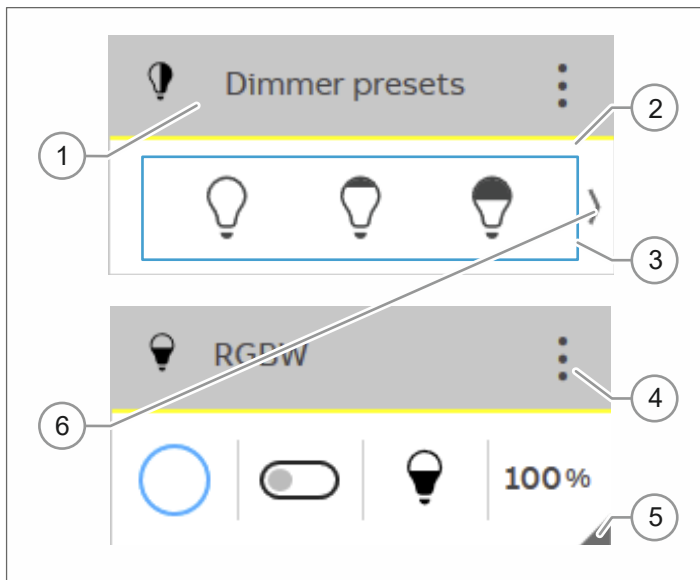

Fig. 51: Basic structures of controls (with the example of different controls)

Pos.	Element	Description of functions
[1]	Headline	The headline shows a series of different primary functions, such as the names of the controls.
[2]	Function line	The function line marks the function group to which the control belongs.
[3]	Buttons	The buttons are displayed in the form of different symbols. Black buttons can be clicked, grey buttons are disabled. Selected or active buttons are displayed in blue. The degree of details can vary depending on the size of the control. Not all buttons can be displayed in small controls.
[4]	Options menu	The options menu can be opened with a click on the three points in the top right corner of the control. The options menu also displays current alarms. If alarms are pending, this is displayed with a warning symbol next to the options menu.
[5]	Triangular symbol	A triangular symbol is displayed in a series of controls when they can be enlarged.
[6]	Arrow buttons	Arrow buttons are displayed in some controls with which one can switch through the different functions in the control (e.g. stepwise dimming from 0% - 25% - 50%).

Table 10: Basic structure of controls

## Options menu

Each control has its own dropdown options menu. Secondary functions (e.g. linkages to schedulers, trends, etc.) as well as active alarms are listed.

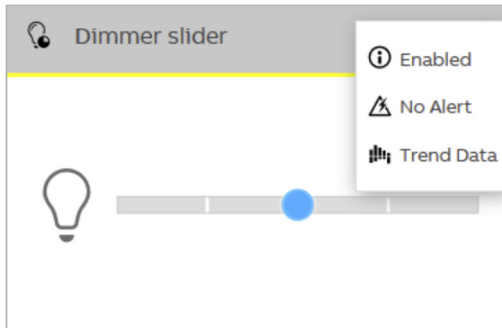

Fig. 52: Options menu

## Open options menu

1. Click on the three points in the top right corner of the headline of a control.
  - The dropdown options menu of the control opens.

If you have opened the dropdown options menu, you can view the different functions and designations of functions including the function-specific symbols.

Current messages are displayed by means of a warning symbol in signal colour. A click on the symbol opens the alarm center (see chapter 10.4.1 “Alarm messages“ on page 310).

## 10.2.2 Additional basic principles

### Function buttons

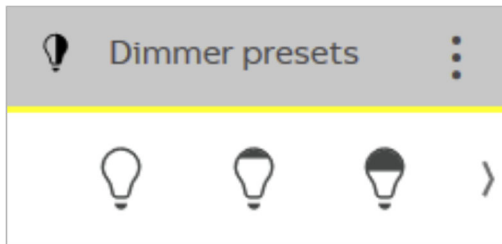

Fig. 53: Basic principles of function buttons

Function buttons of dimming control elements or fan controls, for example, can display different dimming or fan speed levels by means of alternating symbols.

### Highlighting

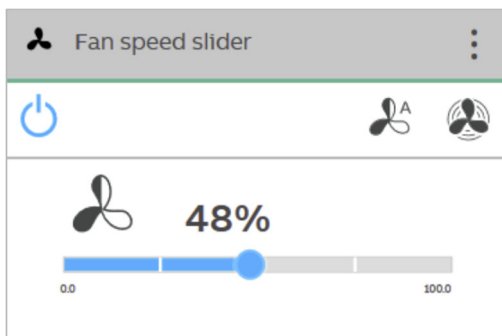

Fig. 54: Highlighting of basic principles

Highlighting serves for the identification of:

- Functions in controls
- Active functions in controls
- Reactions to commands
- Text links
- Tool tips
- Forced controls
- Confirmation buttons

### Primary information

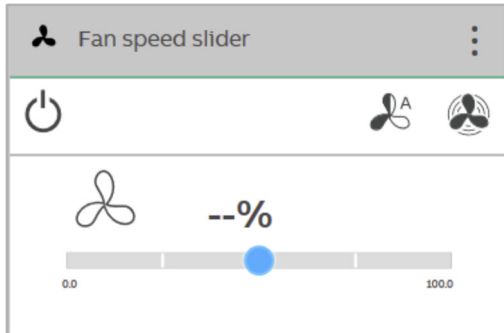

Fig. 55: Basic principles of primary information

Primary information such as status, status symbols, selectable elements and text in the controls are displayed in bold text. This information is greyed out when there is a fault, the necessary user rights are missing, or the element is in an overwrite process.

### Preset values

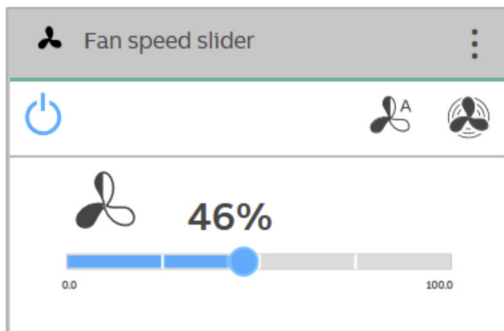

Fig. 56: Basic principles of preset values

Preset values of steps or levels (e.g. dimming steps, fan speed levels) are displayed in bold text.

### 10.2.3 Variable controls



**Notice**

The basic versions described here can be further adjusted.

**Switches (basic version)**

With switches, simple switches can be implemented, such as light switches or switches for simple switching processes.

Control	Status	Function
Switch		When operated, a changeover button sends out one of two values alternately and changes between two statuses (e.g. "On" and "Off").

**Dimmer (basic version can be further adjusted)**

Simple switches can be implemented with push-buttons. This makes light switches or switches for simple switching processes based on push-buttons possible.

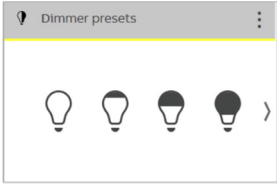
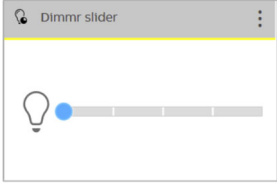
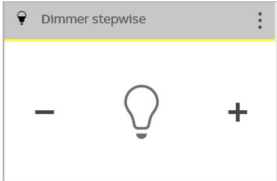
Control	Status	Function
Dimmer preset values		The dimmer version has at least two or more buttons for calling up the previous or the next dimming stage.
Dimmer slider		This dimmer version has a slider button via which the dimming value from 0% to 100% can be regulated on the basis of the specified step width.
Dimmer stepwise		This dimmer version has two buttons to the left and right for stepwise dimming.



**Blind (basic version can be further adjusted)**

Blind controls can be used to implement the activation of blinds, roller shutters and other motor-driven actuators.

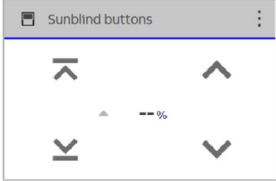
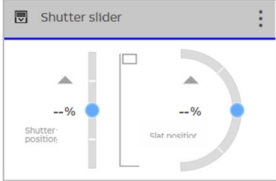
Control	Status	Function
Blind button		<p><b>Blind/roller shutters</b> The button in the middle displays the status in percent.</p> <ul style="list-style-type: none"> <li>▪ <b>Operating procedure:</b> <ul style="list-style-type: none"> <li>– Arrow buttons for "Stepwise Up/Down" and "Down/Up" at the side of the controls.</li> <li>– Arrow buttons for "Left/Right" and "Stepwise Left/Right" at the side of the controls.</li> </ul> </li> <li>▪ <b>Start</b> <ul style="list-style-type: none"> <li>– Depending on the configuration, by pressing or releasing the arrow buttons.</li> </ul> </li> <li>▪ <b>Stop</b> <ul style="list-style-type: none"> <li>– Depending on the configuration, by pressing or releasing the arrow buttons.</li> <li>– When reaching the limit stop.</li> </ul> </li> <li>▪ <b>Change</b> <ul style="list-style-type: none"> <li>– Change of the direction of travel by stopping and selecting the other direction of travel.</li> </ul> </li> </ul>
Blind slider		<p><b>Blind</b> The version with slider has a button for specifying the blind position and a button for aligning the slats.</p> <p><b>Roller shutters</b> The version with slider has a button for specifying the roller shutter position.</p>

### Scenes (basic version)

With the scene controls the user can start so-called "Scenes". Several actions can be combined in a single scene so that the user can create a certain light atmosphere with only one press of the button for example (several dimming actors).

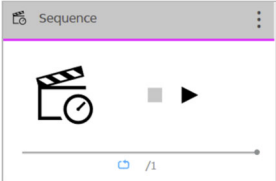
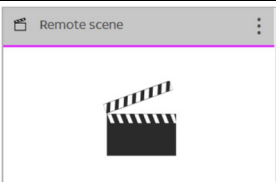
Control	Status	Function
Local scene		<p>The "Local scene" control has a button for enabling and disabling the scene. If several scenes have been specified, the same number of buttons are available.</p> <p>The control has a pop-up button for calling up a list with different scenes. The list closes automatically after a few seconds if no selection has been made. The scene must be selected in the list. The selected scene is then started via the push-button</p> <p>Notice: The scene to be called up must be appropriately assigned beforehand in the IoT Dashboard Tool</p>
Sequence		<p>The "Sequence" control has several buttons for controlling the predefined scene</p> <p><b>Start/Stop</b> The scene can be stopped and started with a click on the button in the middle.</p> <p><b>Pause</b> The scene can be paused with a click on the button on the left.</p> <p><b>Fast-forwarding</b> The scene can be fast-forwarded with a click on the button on the right.</p>
Remote scene		<p>The "Remote scene" control has a button for enabling and disabling the scene. If several scenes have been specified, the same number of buttons are available.</p>

**Fan switch (basic version can be further adjusted)**

Fan switches can be used to implement switching sequences. A Step switch, so to speak, combines several push-buttons into one control.

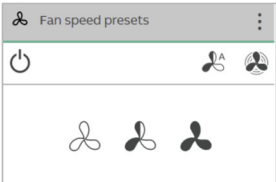
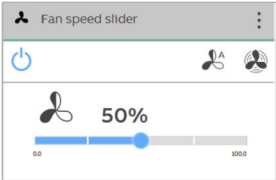
Control	Status	Function
Fan speed preset values		<p>The version has at least two or more buttons for calling up the previous or the next fan speed level.</p> <p><b>Switching on / Switching off</b> The switch-on and switch-off behaviour depends on switch-on and switch-off behaviour parameterised by the installer.</p> <p><b>Additional buttons</b> The availability of additional buttons also depends on the parameterisation.</p>
Fan speed slider		<p>The version with slider has a slider button via which the fan speed level can, for example, be regulated from 0% to 100% on the basis of the specified step width.</p> <p><b>Switching on / Switching off</b> The switch-on and switch-off behaviour depends on switch-on and switch-off behaviour parameterised by the installer.</p> <p><b>Additional buttons</b> The availability of additional buttons also depends on the parameterisation.</p>

## DALI

Individual lights and entire light installations can be activated synchronously via DALI controls.

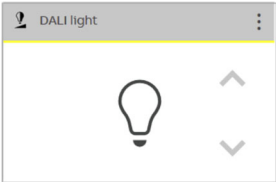
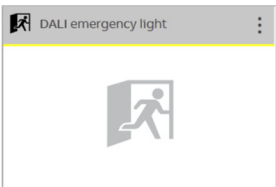
Control	Status	Function
DALI light		<p>The control has at least two or more buttons for calling up the previous or the next fan dimming stage.</p> <p><b>Switching on / Switching off</b> The switch-on and switch-off behaviour depends on switch-on and switch-off behaviour parameterised by the installer.</p> <p><b>Additional buttons</b> The availability of additional buttons also depends on the parameterisation (e.g. Burn-in time, etc.).</p>
DALI emergency light		<p>The information on the status of the DALI emergency lighting is displayed in the "DALI emergency light" control. The information is presented in the form of different symbols and text, which must be assigned beforehand.</p>

## Room temperature controller (basic version)

Climate devices can be controlled with the control for room temperature controllers.

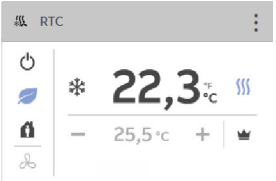
Control	Status	Function
RTC		<p>The current operating mode and the mode (e.g. "Heating") of the controller are displayed in the control.</p> <p>Control is carried out via various buttons.</p>

### RGBW (basic version)

Specific settings can be made for corresponding lamps (LEDs, Philips Hue, etc.) with the RGBW controls. For example, the colours can be changed or the warm-white component can be adjusted

Control	Status	Function
RGBW		<p><b>Switch light on/off light</b> The lamp is switched on or off with the configured colour values with a click/press on the lamp symbol.</p> <p><b>Change RGB colour:</b> The colour value of the lamp is changed with a click/press on the colour picker.</p> <p><b>Change RGB colour with preset:</b> The colour value of the lamp is changed immediately with a click/press on one of the preconfigured colours.</p> <p><b>Setting the brightness value</b> The brightness of the lamp can be set with the slider. The brightness value is selected on the basis of the selected colour.</p>

### Linkages

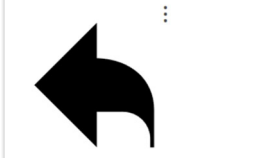

Here a linked page can be transferred to directly.

Control	Status	Function
Page links		<p>Linked pages are called up directly with a click on the defined button.</p>
Image		<p>Linked pages are called up directly with a click on the defined graph.</p>

**Value display elements / value sending elements (basic version)**

With value display elements, values are displayed as text or graphical information. They cannot be operated (exception is the value slider), but serve for the display of values.

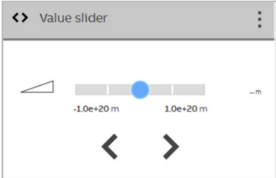
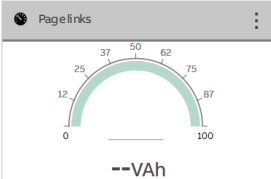
Value sending elements can be used to display values in different formats and to send them to other devices.

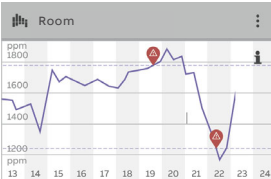
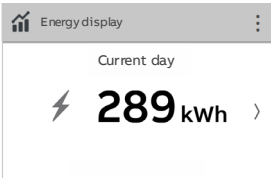
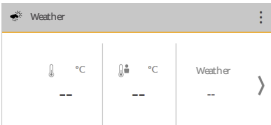
Control	Status	Function
Value for slider		Value sending elements can be used to display values in different formats and to send them to other devices. With the "Value for slider" control, the slider can be used to change values. The changed values are then sent. Text displays can be made here. In this case, a corresponding text can be displayed for the different slider positions.
Gauge		The gauge can show values graphically in a previously specified dimensional unit. The gauge cannot be operated; only a change between the different forms of representation can be made in the control.
Scheduler viewer		The scheduler viewer serves for the visualisation of the sequences specified in the schedulers. Which sequences are displayed depends on the parameterisation.
Trend viewer		The trends on the individual sequences in the system are displayed in the trend viewer.
Energy display		Data about the consumption of energy are displayed in the energy display. The dimensional unit is specified during the creation. Which values are displayed depends on the parameterisation.
Weather		Different data about the weather are displayed in the "Weather" control. Which data are available depends on the parameterisation.

## 10.3 Special functions

### 10.3.1 Edit Mode

The following custom adjustments can be made on the IoT Dashboard. The changes made here are only valid for the respective user who has made the changes. Each user of the IoT Dashboard can make personal changes.

The following changes can be made in the edit mode:

- Arrange, rename and fade out elements anew in the navigation tree
- Create and edit links for current operating pages
- Create and edit favourites list
- Create and edit favourites links

#### Open edit mode

To open the edit mode, proceed as follows:

1. Click on the Burger menu to open the ribbon bar.
2. Click on the pin symbol at the right outside edge of the ribbon bar.
  - The edit mode is enabled.



#### Notice

In the edit mode the individual areas of the user interface can be selected; however, it is not possible to change the contents of the controls.

## 10.3.1.1 Edit navigation tree

The hierarchical arrangement of the building parts in the navigation tree depends on the structure configured in the IoT Dashboard Tool or in the ETS.

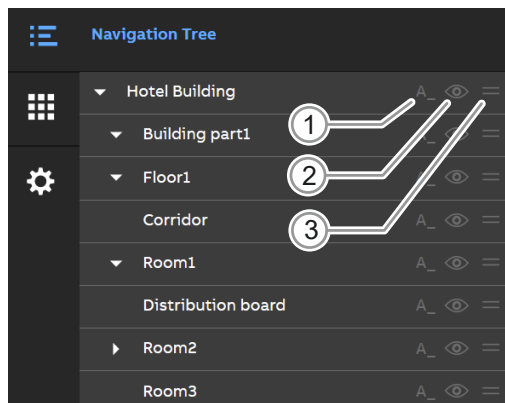

Fig. 57: Edit navigation tree

The following changes can be made in the edit mode of the navigation tree:

- [1] Rename elements (letter symbol)
- [2] Fading elements in and out (eye symbol)
- [3] Rearranging the building architecture (list symbol)



### Notice

Each user can make his own individual changes. Please note that the changes are therefore only valid for the respective user who has made the changes. Elements are not totally lost during changes but are only faded out for the respective user.

### Rename elements

1. Open the navigation tree.
2. Click on the pin symbol.
  - The navigation tree is now in edit mode.
3. Select any element.
4. Click on the "A\_" button.
5. Assign a new name.
6. Confirm your entry with Enter or a click in a free area.

### Fading elements in and out

1. Open the navigation tree.
2. Click on the pin symbol.
  - The navigation tree is now in edit mode.
3. Select any element.
4. Click on the eye symbol
  - If the eye symbol is crossed through, the element is faded out.



## Rearranging the building architecture

1. Open the navigation tree.
2. Click on the pin symbol.
  - The navigation tree is now in edit mode.
3. Hold the mouse pointer over the list symbol of any element.
  - The mouse pointer symbol changes to an arrow cross.
4. Hold the mouse button pressed and pull the element to the desired position via drag and drop.



### **Notice**

If you move an overriding element in the building structure, all subordinate elements are also arranged anew.

### 10.3.1.2 Call-up and editing of the favourites page

The favourites page ("Favourites") is a custom operating page that each user can personalise. It can be opened from anywhere within the IoT Dashboard.



#### Notice

Each user can make his own individual changes. Please note that the changes are therefore only valid for the respective user who has made the changes.

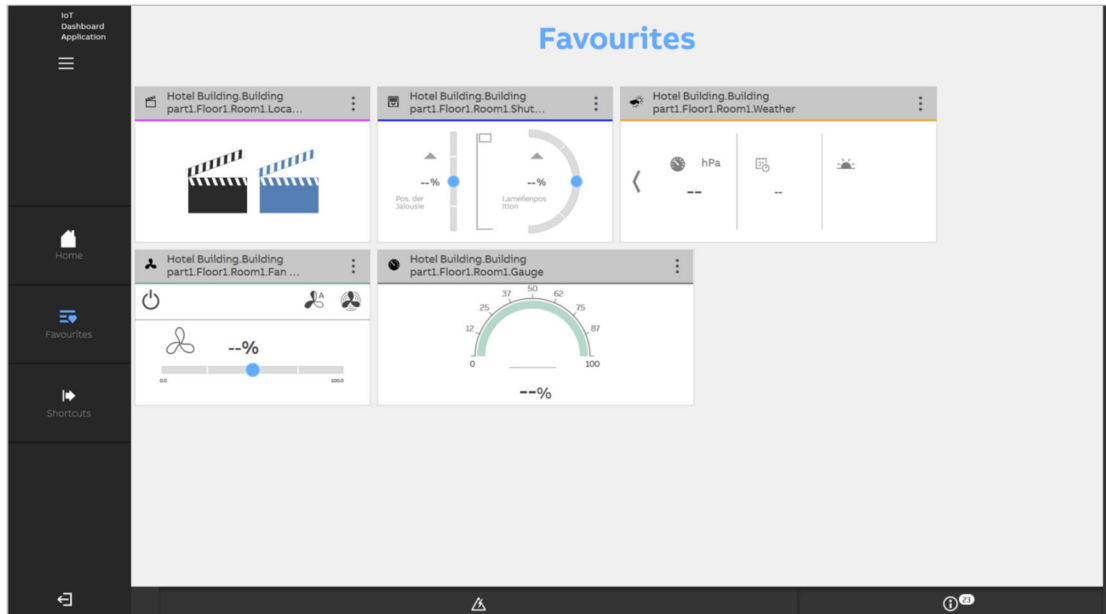

Fig. 58: Call-up and editing of the favourites page

The controls are displayed on the favourites page in the same order as they were added (see chapter 10.3.1.1 "Edit navigation tree" on page 304). The following changes can be made in the edit mode:

- Rearrange controls
- Adjust the size of the controls
- Rename the controls
- Remove the controls from the favourites page

#### Reposition control/adjust the size

1. Open the favourites page.
2. Select a control.
3. Click on the corners of the control and pull it to the desired size.
4. Change the position of the control by pulling it to the desired position via drag and drop.

### **Rename control**

1. Open the favourites page.
2. Select a control.
3. Click on the "A\_" button to rename the control.
4. Assign a new name.
5. Confirm the change with a click in a free area.

### **Remove the control from favourites**

1. Open the favourites page.
2. Select a control.
3. Click on the heart symbol.
  - The control is removed from the favourites page.

## 10.3.1.3 Creating and editing links

Links are custom links for controls of the IoT Dashboard. Each control can additionally be added as link. All added links can be called up via the ribbon bar.

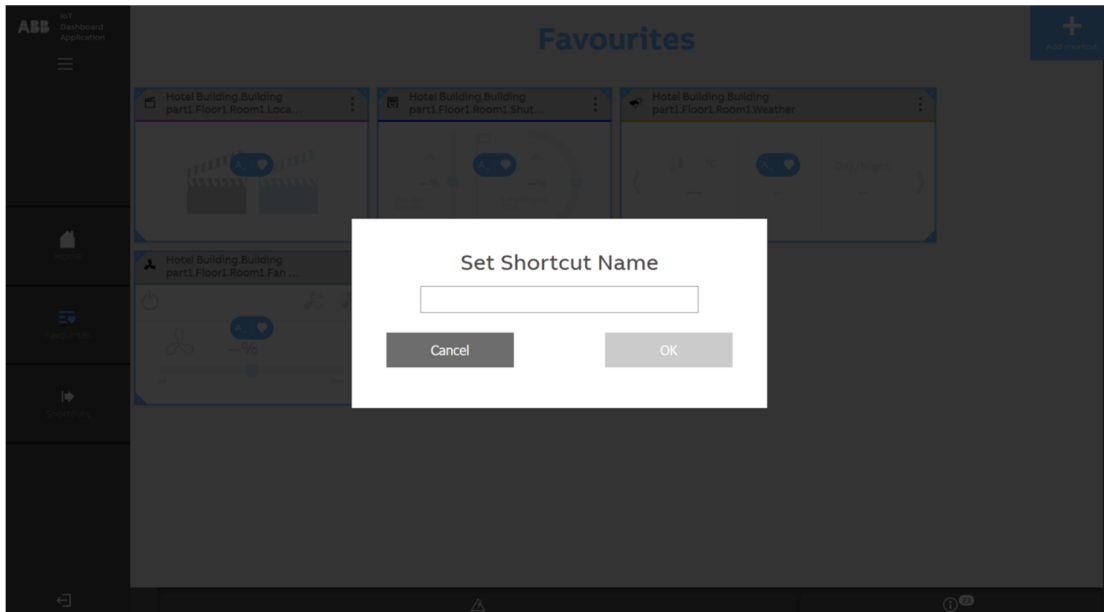

Fig. 59: Creating and editing links

In each link custom filters or settings are stored for the corresponding operating page. Links are valid as soon as an operating page or an area is selected as link entry.



### Notice

To enable the system to be operated via the IoT Dashboard, the user rights must be assigned in such a way that users can rearrange, delete or rename links (see chapter 8.6 “User rights“ on page 67).

### Creating links

You can create links for any operating pages and areas of the IoT Dashboard . To do this, proceed as follows:

1. Change to the operating page or the area for which you want to create a link.
2. Click on the Burger menu to open the ribbon bar.
3. Click on the pin symbol at the top right edge of the ribbon bar to change to the edit mode.
4. Click on the "Add link" button at the top right edge of the screen.
  - The "Name link" menu opens.
5. Enter a name and confirm it with "OK".
  - The link is added to the list in the "Links" menu.

### Rename links

When a new link is added to the IoT Dashboard , you are requested to assign a meaningful name. If you want to change the name at a later point in time, proceed as follows:

1. Open the ribbon bar.
2. Open the "Links" menu with a click.
3. Select the link you want to rename.
4. Click on the "A\_" button.
  - The name of the link receives a white background and can be edited.
5. Assign a new name.
6. Confirm with Enter or a click on an area outside the link.
  - The new name is saved.

### Rearranging links

1. Change to the ribbon bar.
2. Open the "Links" menu with a click.
3. Hold the mouse pointer over the list symbol of any link.
  - The mouse pointer symbol changes to an arrow cross.
4. Click on the link and keep the mouse button pressed.
5. Hold the mouse button pressed and pull the element to the desired position via drag and drop.

### Deleting links

1. Change to the ribbon bar.
2. Open the "Links" menu with a click.
3. Select the link you want to delete.
4. Click on the waste-paper basket symbol at the left of the link.
  - An open waste-paper basket symbol appears at the right edge of the link.
5. Click on the open paper basket.
  - The link will be totally deleted.

## 10.4 Control actions of additional applications

Applications are executed as full-screen programs in the IoT Dashboard. Applications can be either native or made available by third parties.

### 10.4.1 Alarm messages

The alarm center can be opened with a click on the corresponding symbol at the bottom edge of the screen from almost all areas of the IoT Dashboard.

All messages are listed in a list view. In addition, for each message there are details about type and name, a description of the alarm, the trigger, the time of triggering, as well as the current status. Current and historical messages ("Current" and "Historic") can be seen in the overview.

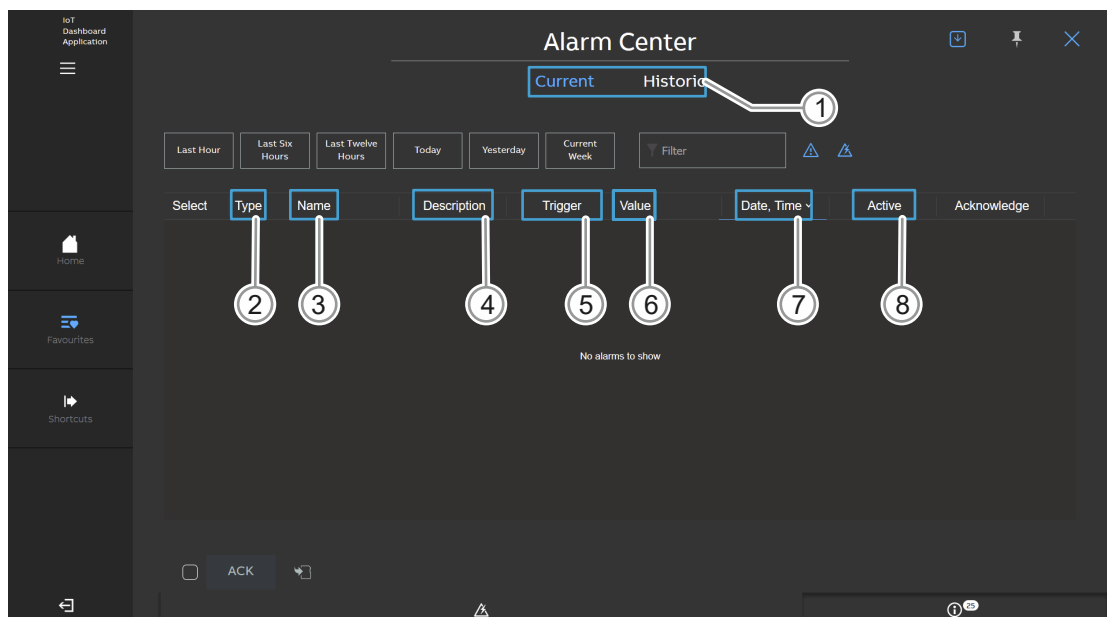

Fig. 60: Alarm messages

Pos.	Description of functions				
[1]	<p><b>Current and historic</b></p> <p>All active messages of the building automation are displayed under "Current". All messages that are currently stored in the system are displayed under "Historic".</p> <p><b>Notice:</b> Users can view and access messages only if they have the necessary rights.</p>				
[2]	<p><b>Alarm types</b></p> <p>The two alarm types "Alarm" and "Warning" are differentiated. The blue warning triangles can be used to also filter for the two alarm types.</p> <table border="1"> <thead> <tr> <th>Alarm</th> <th>Warning</th> </tr> </thead> <tbody> <tr> <td> <ul style="list-style-type: none"> <li>– Marks critical messages that require special attention.</li> <li>– Must be confirmed by the user ("ACK").</li> <li>– Are triggered when the threshold value predefined as trigger has been reached.</li> <li>– Disappears only when the predefined threshold value again drops below the set value and the notification is confirmed by the user ("ACK").</li> </ul> </td> <td> <ul style="list-style-type: none"> <li>– Marks important messages which do not involve critical system conditions.</li> <li>– Must not be confirmed by the user ("ACK").</li> <li>– Are triggered when the threshold value predefined as trigger has been reached.</li> <li>– The warning is shifted from "Current" to "Historic" as soon as the predefined threshold value again drops below its set value.</li> </ul> </td> </tr> </tbody> </table>	Alarm	Warning	<ul style="list-style-type: none"> <li>– Marks critical messages that require special attention.</li> <li>– Must be confirmed by the user ("ACK").</li> <li>– Are triggered when the threshold value predefined as trigger has been reached.</li> <li>– Disappears only when the predefined threshold value again drops below the set value and the notification is confirmed by the user ("ACK").</li> </ul>	<ul style="list-style-type: none"> <li>– Marks important messages which do not involve critical system conditions.</li> <li>– Must not be confirmed by the user ("ACK").</li> <li>– Are triggered when the threshold value predefined as trigger has been reached.</li> <li>– The warning is shifted from "Current" to "Historic" as soon as the predefined threshold value again drops below its set value.</li> </ul>
Alarm	Warning				
<ul style="list-style-type: none"> <li>– Marks critical messages that require special attention.</li> <li>– Must be confirmed by the user ("ACK").</li> <li>– Are triggered when the threshold value predefined as trigger has been reached.</li> <li>– Disappears only when the predefined threshold value again drops below the set value and the notification is confirmed by the user ("ACK").</li> </ul>	<ul style="list-style-type: none"> <li>– Marks important messages which do not involve critical system conditions.</li> <li>– Must not be confirmed by the user ("ACK").</li> <li>– Are triggered when the threshold value predefined as trigger has been reached.</li> <li>– The warning is shifted from "Current" to "Historic" as soon as the predefined threshold value again drops below its set value.</li> </ul>				

[3]	<b>Name</b> The name of the message is displayed in the "Name" area.	
[4]	<b>Description</b> The message is described in the "Description" area. Also the area of the building in which the message originated is indicated.	
[5]	<b>Triggers</b> The trigger of the respective message is displayed under "Trigger".	
[6]	<b>Value</b> The value which caused the alarm is displayed under "Value".	
[7]	<b>Date / Time</b> The time of triggering is displayed under "Date/Time".	
[8]	<b>Active</b> Whether the message is currently active or has already been cancelled is displayed under "Active".	
	<b>Active</b> The message is active when the predefined threshold value has been reached.	<b>Inactive</b> The message is inactive when the predefined threshold value has dropped below its set value.

### Filtering and sorting messages

All current messages are displayed in form of a list in the alarm center. You can use different filtering options:

- Filtering according to timescale
- Filtering via key term
- Filtering according to message type

- **Filtering according to timescale**

In the "Current" overview you can filter messages from the following timescales with a click on one of the predefined buttons.

- Last hour
- Last six hours
- Last twelve hours
- Today
- Yesterday
- Current week



#### Notice

In the "Historic" overview you can filter in a certain timescale only on the basis of the date.

### ▪ Filtering according key term

The filter symbol can be used to filter in the current and in the historic view in all columns on the basis of key terms. The individual columns can be rearranged via drag and drop. Sorting can be adjusted with a double click.



#### **Notice**

If you have filtered alarms already on the basis of a certain timescale, you can use key terms to further limit the messages to be searched.

### ▪ Filtering according to message type

You can filter on the basis of message types via warning symbols. To do this, select the symbol for alarms or warnings, or both symbols simultaneously.

### **Confirm messages (ACK)**

Confirm individual messages:

1. Click on the "ACK" button on the right next to the message you want to confirm.
  - A dialogue window opens.
2. Enter a comment to the message as an option (e.g. the editing status of the problem the message is based on).
3. Click on "Send" to confirm or "Cancel" to continue without a comment.

### **Confirm several messages (ACK)**

1. Set a tick for each message you want to confirm.
2. Click on the "ACK" button below the list.
  - A dialogue window opens.
3. Enter a comment to the message as an option (e.g. the editing status of the problem the message is based on).
4. Click on "Send" to confirm or "Cancel" to continue without a comment.



#### **Notice**

As soon as a message has been confirmed, it receives a time stamp and the information about the user who confirmed the message. In addition, the comment added as an option can be viewed.



## 10.4.2 Notification Center

Each "Notification center" is a fold-out list that can superimpose the other areas of the IoT Dashboard. As soon as an area outside the notification center is clicked on, the window closes by itself. The notification center can be opened from almost all areas of the IoT Dashboard and displayed as information symbol at the bottom right edge of the screen.

The notifications about alarms, system information and updates are displayed in the notification center.



### Notice

Even when the notification center is not folded out, a bubble with the number of the newly available notifications is displayed next to the information symbol at the bottom right edge of the screen. The number of the notifications decreases as soon as you have read a notification and is raised with the receipt of each new notification.

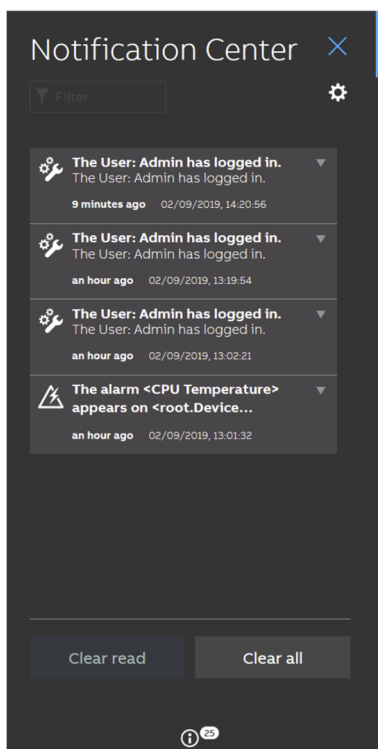

Fig. 61: Notification center

### Read notifications

1. Open the notification center with a click on the information symbol at the bottom right edge of the screen.
2. Click on the notifications you want to open.
3. Click on the arrow symbol of a notification to obtain detailed information.
4. Click again on the arrow symbol of a notification to close the detail view.



### Notice

Some notifications also contain a hyperlink via which you are transferred to a different area of the IoT Dashboard.

## Subscribe notifications

You have the option to define the controls, elements and applications for which you want to receive e-mail notifications and the controls, elements and applications you want to subscribe to.



### Notice

The notifications you can view and subscribe to depends on the configurations made in the IoT Dashboard Tool. You can only view the notifications the system integrator has enabled for your user group.

- At the first login you are registered for all categories of notifications that the administrator has enabled for your user group.
- You can subsequently unsubscribe or subscribe to again only for certain categories (new categories you cannot subscribe to).

1. Open the notification center with a click on the information symbol at the bottom right edge of the screen.
2. Set a tick at each element for which you want to receive notifications. To do this, fold the elements of the building structure in and out.
3. Also set a tick at each element for which you want to receive notifications via e-mail.
4. And finally, click on the "Apply" button.

## Filter notifications

To obtain a better overview of current notifications, you can set any filter from the list of predefined filters with which you want to limit the notifications.

1. Open the notification center with a click on the information symbol at the bottom right edge of the screen.
2. Click on the filter symbol in the notification center.
  - A list with available filter options opens.
3. Enable the checkbox for each filter option with which you want to filter.
4. Click on "Apply".

## Delete stored data

The option "Delete stored data" can be used to finally delete notifications from the data base from a certain timescale for a certain element.

1. Open the notification center with a click on the information symbol at the bottom right edge of the screen.
2. Select an element whose stored data you want to delete.
3. Click on the paper basket symbol.
  - The menu "Delete stored data" opens.
4. Use the specified buttons or the scheduler to select any timescale whose data are to be deleted.
5. Click on the button with the paper basket symbol.
  - The lid of the paper basket is displayed open.
6. Click again on the button to confirm.

## Delete notifications

Via the buttons "Delete those read" and "Delete all" you can delete either only read ones (delete those read) or all existing messages (delete all) simultaneously from the notification center. The stored data remain stored.

1. Open the notification center with a click on the information symbol at the bottom right edge of the screen.
2. Click either on button "Delete those read" or on button "Delete all".

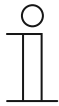

### Notice

If the filter is active, only the filtered notifications are deleted.

### 10.4.3 Schedulers

The "Scheduler" application can be opened in the IoT Dashboard via the ribbon bar. Events or event sequences can be executed automatically via schedulers at the specified times.

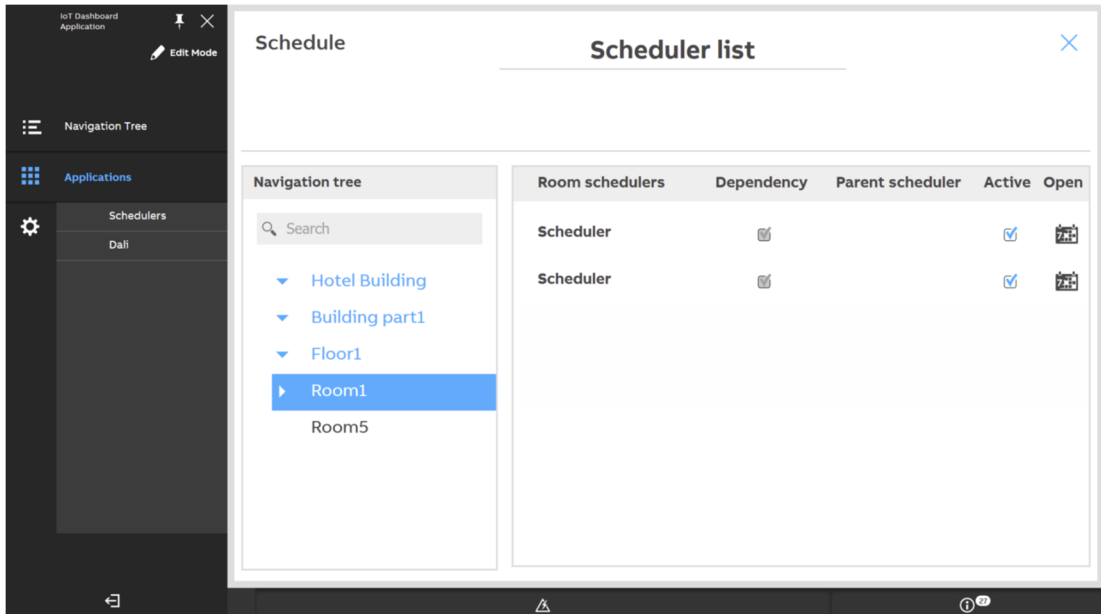

Fig. 62: IoT Dashboard Schedulers

Events are displayed in the different views on the timeline as function symbol. The configured value (e.g. dimming value) is displayed above the symbol.

Events can be moved along on the timeline. The values of individual elements can also be adjusted.

Schedulers can be seen and configured in three different views.

View	Description
Today	In the "Current day" view, all events from the weekly view and all exceptions are displayed that are triggered on the respective day. The table is empty if no events have been configured. If exceptions are configured under "Current day", these have the highest priority and overwrite the weekly and standard exceptions that are normally predefined for this day.
Weekly	In the "Weekly" view, all events are displayed that are triggered within the week. Weekly events have the lowest priority during triggering of events. The weekly plan is active as long as the date is within the start and end time previously specified in the settings, or the current date does not deviate from an exception.
Exceptions	Under "Exceptions" all events are displayed that are triggered in the weekly view. Here configured exceptions have a higher priority than the exceptions configured in the weekly view. Exceptions from this view always refer only to the corresponding time program. Individual exceptions must be defined for each time program.

Table 11: Schedulers - Views

## User rights

Users can make changes (overwrite schedulers, change or add events, enable/disable schedulers) only if they have the corresponding rights. Users without these rights only have read rights.



### Notice

Depending on the assigned user rights, the visualisation can vary. In the following descriptions it is assumed that the user has the corresponding rights for changing the settings.

## Open scheduler

1. Click on the Burger menu to open the ribbon bar.
2. Click in the ribbon bar on the "Applications" option.
  - A list with available applications opens.
3. Select the "Scheduler" application.
  - The scheduler application opens. The information is displayed in the scheduler list.
4. In the navigation tree navigate through the building structure and click on an element whose scheduler you want to open.
  - All schedulers of an element are displayed in the right area of the scheduler list.
5. Click on the scheduler symbol under category "Open" to open the desired scheduler.

## Enable/disable scheduler

Schedulers can be enabled or disabled.

1. Open a scheduler (see See "Open scheduler" on page 317).
2. Click on the checkbox of option "Scheduler active" to enable or disable the scheduler.
  - When the scheduler is disabled, this is marked with a crossed through scheduler symbol above the "Scheduler active" option.



### Notice

Disabled schedulers can continue to be viewed by users; however, all buttons are greyed out.

## Reset view

The views "Today" and "Weekly" can be reset to the standard scheduler. To do this, proceed as follows:

1. Open a scheduler (see See "Open scheduler" on page 317).
2. Change to the view "Today" or "Weekly".
3. Click on the "Reset" button.
  - The view is reset to the standard scheduler

### **Delete all events**

1. Open a scheduler (see See "Open scheduler" on page 317).
2. Change to the view "Today" or "Weekly".
3. Click on the "Delete all" button.
  - All events are deleted from the time line.

### **Related schedulers**

The "Related schedulers" button can be used to open a dropdown list with all schedulers belonging to a room. The list only contains schedulers that are valid for a room. The building structure is opened automatically in the list via which the currently open scheduler can be reached. The currently activated schedulers are displayed under "Enabled".

▪ **General settings**

Fig. 63: General settings

With a click on the gearwheel symbol of the scheduler configuration at the top right edge of the screen, you can make general settings to a scheduler.

**Active period**

If the scheduler has expired, this is signalled via a small warning sign next to the gearwheel symbol. Timescales for the validity of scheduler can be defined, if required, under start and end.

1. Enable the checkbox at "Start".
2. Specify a starting time.
3. Enable the checkbox at "End".
4. Specify an end time.
5. Click "Save" to save the changes.

**Configure notifications**

Under "Notify me when..." you can specify the conditions under which you want to receive notifications.

1. Enable each of the following options for which you want to receive a notification:
  - ...the scheduler has been enabled.
  - ...the scheduler has been disabled.
  - ...the scheduler has been triggered.

### **Scheduler list**

The scheduler list can be used to prevent commands within the building from overlapping.

1. Open the scheduler list with a click on the "Scheduler list" button.
  - All schedulers are displayed in the scheduler list on the basis of the building architecture.
2. Enable or disable schedulers by setting a tick at the respective checkbox.



### 10.4.3.1 Today

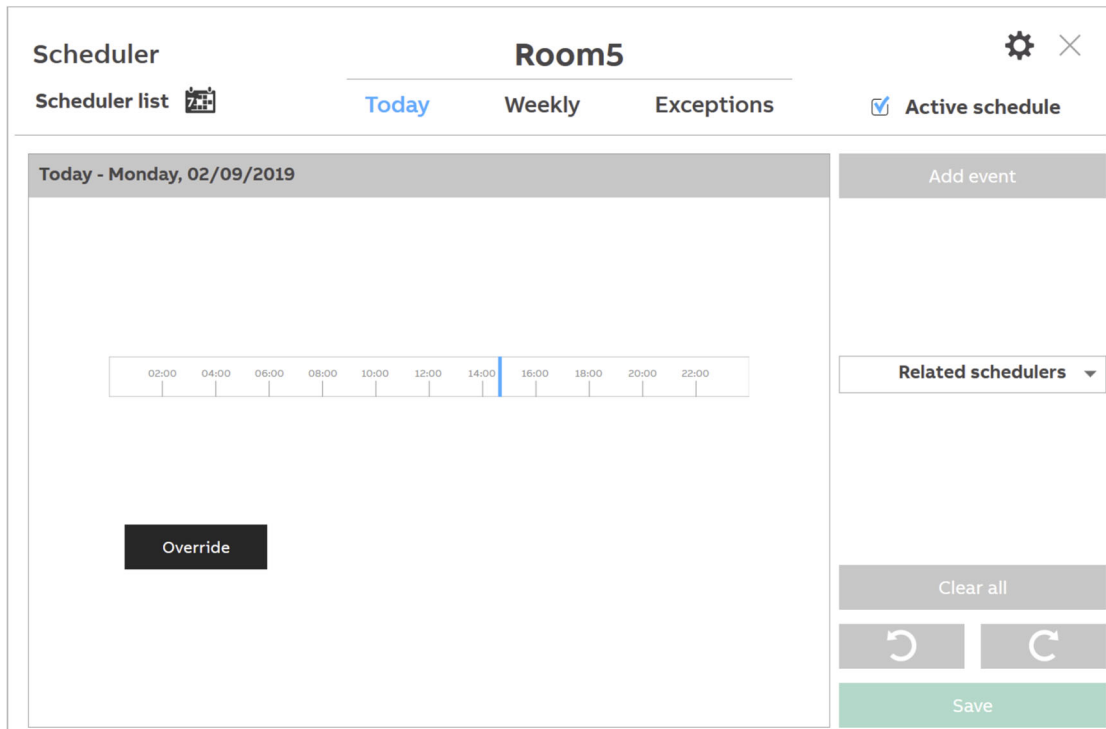

Fig. 64: Today

In the "Today" view, all events are displayed that are triggered on the current day. The events are defined in the views "Weekly" and "Exceptions". Exceptions that have been specified for the current day have the highest priority and overwrite all standard exceptions that should be executed on the respective day. The changes made are individual and therefore only valid for the respective user who has made the changes.

#### Overwrite today

The scheduler for the current day you can overwrite as follows:

1. Open a scheduler whose events you want to edit.
2. Change to the "Today" view.
3. Click on the "Override" button.
  - You can now overwrite the scheduler for the current day.
4. Click on the "Add event" button.
5. Pull a function onto the timeline via drag and drop.
6. Change the time of the event. For this there are two options:
  - Move the event along on the timeline via drag and drop.
  - Click on the event and then on the arrow buttons to display the plus and minus keys. Adjust the time with a click on the plus and minus keys.
7. Click on the function symbol and then on the function name to adjust the values of the element (e.g. specifying of dimming brightness or fan speed level).
8. Under "Active for:", enter the period of validity of the event.
  - The validity can be specified to "Today", "Tomorrow" or "Today and tomorrow".
9. Take over the adjustments with a click on the "Save" button.

10.4.3.2 Weekly

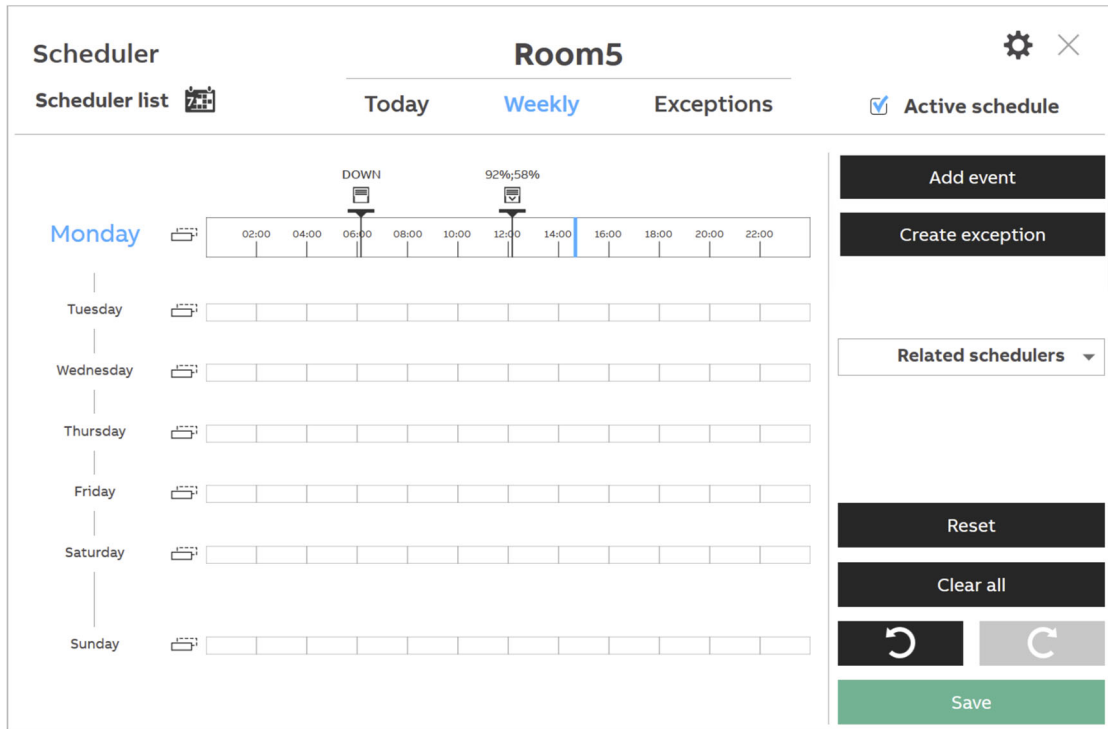

Fig. 65: Weekly

Users can change existing events on the timeline or add new elements or categories of elements to the timeline. Users can make changes only if they have the corresponding rights. Users without these rights only have read rights.



**Notice**

Events, elements or categories of elements can only be added to the timeline when they were predefined beforehand in the IoT Dashboard Tool.



**Notice**

Depending on the assigned user rights, the visualisation can vary. In the following descriptions it is assumed that the user has the corresponding rights for changing the settings.

## Edit events

Existing events can be edited in the "Weekly" view. The changes made are individual and therefore only valid for the respective user who has made the changes.

1. Open a scheduler (See "Open scheduler" on page 317) whose events you want to edit.
2. Change to the "Weekly" view.
3. Use a click to select the weekday whose events you want to edit.
4. Select an event you want to edit.
5. Change the time of the event. For this there are two options:
  - Move the event along on the timeline via drag and drop.
  - Click on the event and then on the arrow buttons to display the plus and minus keys. Adjust the time with a click on the plus and minus keys.
6. Click on the function symbol and then on the function name to adjust the values of the element (e.g. specifying of dimming brightness or fan speed level).
7. Take over the adjustments with a click on the "Save" button.



### Notice

If several events occur at the same time, they are displayed on the timeline within a list. In the preview the events are displayed as number that provides information about the number of events that are in the list.

### Add new events

In the "Weekly" view additional events can be added within the scheduler configurations.

1. Open a scheduler (See "Open scheduler" on page 317) whose events you want to edit.
2. Click on the "Add event" button.
  - A drop-down menu with all available functions opens.
3. Select a function and pull it via drag and drop to any position into any weekday.
4. Click once on the function symbol.
  - The function menu opens.
5. Change the time of the event. For this there are two options:
  - Move the event along on the timeline via drag and drop.
  - Click on the event and then on the arrow buttons to display the plus and minus keys. Adjust the time with a click on the plus and minus keys.
6. Specify a time by moving the function on the timeline, or adjust the time with a click on the arrow symbol in the middle of the menu.
7. Click on the function symbol and then on the function name to adjust the values of the element (e.g. specifying of dimming brightness or fan speed level).

### Duplicate timeline

A timeline for a day can be copied into one or several days of the weekly view via drag and drop.

1. Open a scheduler (See "Open scheduler" on page 317) whose events you want to edit.
2. Select the day to be copied and click on the copy symbol.
3. Keep the copy symbol pressed.
4. Pull the weekday with the timeline to be copied onto the day into which you want to copy the timeline.
5. Release the timeline.
  - If the copying process is successful, the copied timeline is briefly highlighted in colour.

### 10.4.3.3 Exceptions

The screenshot shows the 'Scheduler' interface for 'Room5'. At the top, there are tabs for 'Today', 'Weekly', and 'Exceptions', with 'Exceptions' selected. A 'Scheduler list' icon is on the left, and a 'Active schedule' checkbox is on the right. Below the tabs, there is a 'New exception' form. The form includes a time scale from 02:00 to 22:00. To the right of the form are buttons for 'Add event', 'Create exception', 'Reset', 'Clear all', and 'Save'. Below these buttons are 'Related schedulers' and 'New exception' buttons. The form fields include 'Name of the exception' (New exception), 'Date type' (Unique day selected, Range of days), 'Priority' (8 (default)), and 'Date definition' (Any day of the month, Any weekday, Any month, Any year).

Fig. 66: Exceptions

The "Exceptions" view can be used to view timescales that are stored in the weekly scheduler. Events defined as exceptions have a higher priority than weekly events.

Defined exceptions are added only to the scheduler that is currently open. An own exception must be defined for each additional scheduler.

#### Edit exceptions

Existing exceptions can be edited. Aside from the assignment of a new name, also data type (single day, sequence of days, complete week), priority and date can be specified.

1. Open a scheduler (See "Open scheduler" on page 317) whose events you want to edit.
2. Change to the "Exceptions" view.
3. Select the exception to be changed.
4. Make the desired changes.
5. Save the changes with a click on "Save".

### **Add new exceptions**

1. Open a scheduler (See "Open scheduler" on page 317) whose events you want to edit.
2. Change to the "Exceptions" view.
3. Click on the "Add exception" button.
4. Pull the exception event onto the timeline via drag and drop.
5. Change the time of the event. For this there are two options:
  - Move the event along on the timeline via drag and drop.
  - Click on the event and then on the arrow buttons to display the plus and minus keys. Adjust the time with a click on the plus and minus keys.
6. Click on the function symbol and then on the function name to adjust the values of the element (e.g. specifying of dimming brightness or fan speed level).
7. Take over the adjustments with a click on the "Save" button.

### 10.4.4 Trend viewer

The trend viewer can be accessed either via the "Trend viewer" control or the ribbon bar. The trend viewer can be used to view different predefined values from a specific timescale in relation to each other in a graph.

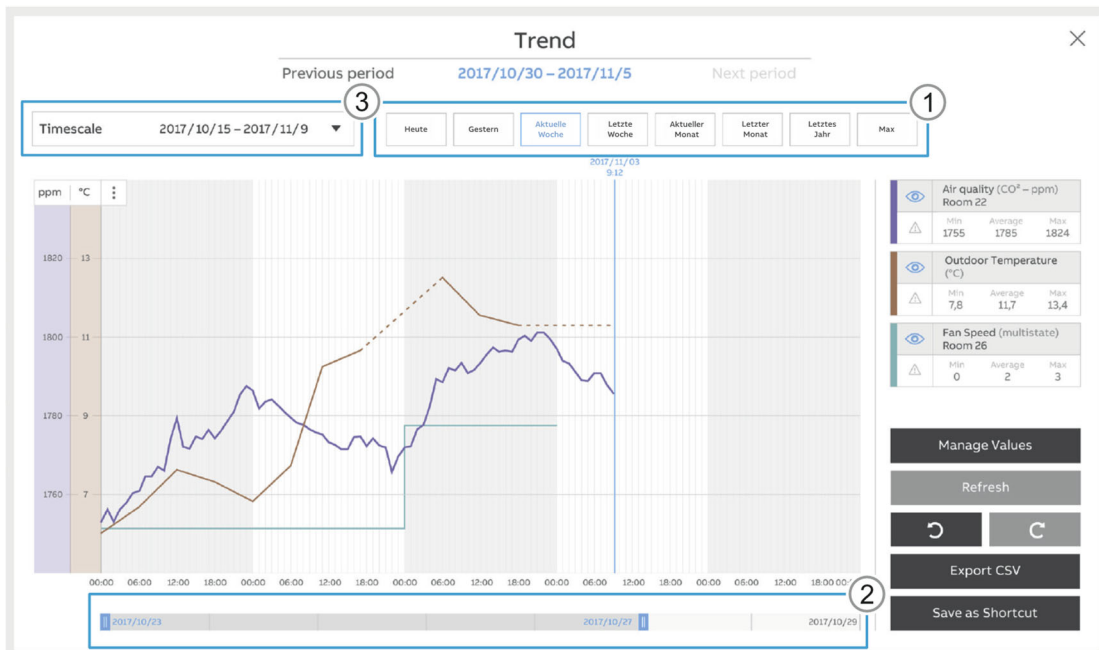

Fig. 67: Trend viewer

To be able to easily read the graph, tool tips in form of a small pin appear in the graph when the mouse pointer is moved across the graph. The values and intervals are displayed in a list with a click on a tool tip.

The current time is displayed in the graph as a blue vertical line. Broken lines in the graph show errors, such as network failures. As soon as a new data point is received, the broken line connects the two data point again with each other.

## Adjust time axis

There are a number of options to adjust the viewed timescale on the time axis.

Timescale	Description
[1] Predefined timescale	<p>The following predefined timescales are available.</p> <ul style="list-style-type: none"> <li>▪ Today</li> <li>▪ Yesterday</li> <li>▪ Current week</li> <li>▪ Last week</li> <li>▪ Current month</li> <li>▪ Last month</li> <li>▪ Last year</li> <li>▪ Max</li> </ul> <p>The buttons "Last timescale" and "Next timescale" above the predefined timescales can be used to change to the previous or the next timescale.</p>
[2] Timeline	<p>The timeline in the bottom area of the application can be used to leaf through the selected timescale. By reducing the size of the viewed timeline, also the size of the timescale can be reduced.</p>
[3] Individual timescale	<p>Aside from the predefined periods, also an individual period can be defined via the timescale. There are no predefined buttons for individual timescales.</p>

Table 12: Adjust time axis

### Defining individual timescales

1. Click on the timescale.
2. Select a year.
3. Select the desired starting time.
4. Select the desired end time.
5. Click on "Apply" to confirm the setting.

### Edit Y-axis

You can set the values to be depicted on the Y-axis. Available are various possible combinations. A maximum of four different values can be displayed on the Y-axis.

1. Click on the three points at the top left in the trend viewer to adjust the Y-axis.
  - The possible values are displayed.
2. Specify which value is to be displayed on which axis by setting a selection.



## Display additional values

You can add new values to the graph as follows:

1. Click on the "Manage values" button.
  - The "Manage values" menu opens.
2. Navigate through the available values in the building structure and select the desired values by setting a tick under "Display in diagram".
  - Values already selected have a tick.
3. Confirm your selection with the "Apply" button.



### Notice

If an overriding element is selected, all subordinate values are selected and the group symbol changes.

## Delete stored values

Only values that are currently visible in the graph can be deleted.

1. Click on the "Manage values" button.
  - The "Manage values" menu opens.
2. Navigate through the available values and select the value to be deleted.
3. Click on the paper basket symbol.
  - The menu "Delete stored data" opens.
4. Specify the timescale from which the values are to delete.
5. Click on the paper basket symbol to confirm the selection

## Create CSV Export

You have the option to export values from the trend viewer into a CSV file. To do this, proceed as follows:

1. Click on the "Export CSV" button.
2. Specify a memory location and confirm it.
  - The CSV export is created.

## Exit applications /Save links

1. Exit the application either via the X at the top right edge of the screen or via the navigation tree.
2. Click on Save if you want to save your view as a link.
  - A menu opens in which you can save your own statistics view as a link.
3. Fix the link.
4. Click on "Save".

### 10.4.5 Energy display

The "Energy display" application can be opened via the ribbon bar or the "Energy display" control. The consumption of energy can be monitored via the application. The following four values can be monitored:

- Electricity
- Water
- Gas
- Consumption of renewable energy

The viewed values are displayed respectively in the overview in an own graph. Also associated sub meters can be viewed for each value. Depending how granular timescales were defined, different information can be displayed.

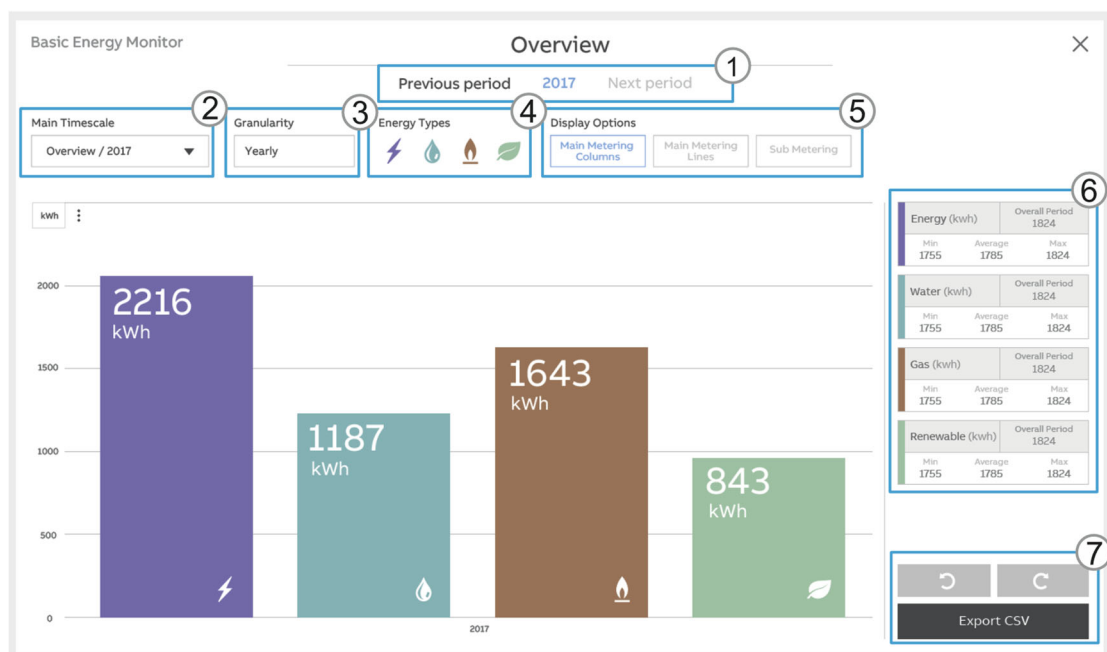

Fig. 68: Energy display

- [1] Timescales
- [2] Main timescale
- [3] Granularity
- [4] Energy type
- [5] Display options
- [6] Sub meters
- [7] CSV export

Pos.	Description of functions
[1]	The options can be used to switch between different timescales.
[2]	Timescales can be set via the main timescale dropdown menu.
[3]	The granularity changes in dependence of the specified main timescale.
[4]	The buttons can be used to switch between the different energy types.
[5]	The display options can be used to set how and which values are to be displayed in the graph.
[6]	Here the different selected values of the sub meters are displayed.
[7]	The values displayed in the energy display can be exported in a CSV file.

### **Edit timescale**

1. Click on the menu below the option "Main timescale".
  - A scheduler menu opens.
2. Specify any timescale.
  - Depending on the selected timescale, the accuracy of the displayed information is specified.
  - The graph is reloaded.
3. Click on the "Undo" button if you want to reset the graph.
4. Use the "Previous period" and the "Next period" buttons to switch to the previous or next period.

### **Change displayed value categories**

With a click on the corresponding button symbol under "Energy types" you can change the category of the viewed values.

### **Edit display options**

If you want to display only one value category in place of the overview, you can change the representation under "Display options". To do this, click on one of the three selection options. The following options are available:

- Column diagram
- Line diagram
- Part measurement diagram

### **Display sub metering**

1. Select the option "Sub metering" under "Display options".
2. Select all sub meters on the right edge of the screen that are to be displayed in the part measurement diagram.
  - If the part information of sub metering cannot be viewed due to a lack of space, you can view them within a tool tip. To do this, move with the mouse across the corresponding area.

## Editing displayed data

The values to be displayed can be adjusted via the three points in the top right edge of the graph.

1. Set a tick at each value to be displayed.

The following options are available:

- Display grid in diagram
- Display data in diagram
- Display consumption
- Display external data
- Point x



### Notice

When external data are displayed in the graph, they superimpose the internal data.

## Export data

1. Click on "Export CSV" to export data as CSV format.
  - Depending on the selected timescale, different data granularities are available in the export menu (monthly, weekly, daily, hourly).

10.5 App applications

10.5.1 DALI Manager (App application)



**Notice**

The DALI manager is an application that needs to be acquired additionally at a charge.

▪ **General**

General information is made available on page "General" of the DALI manager. Also general settings can be made in addition.

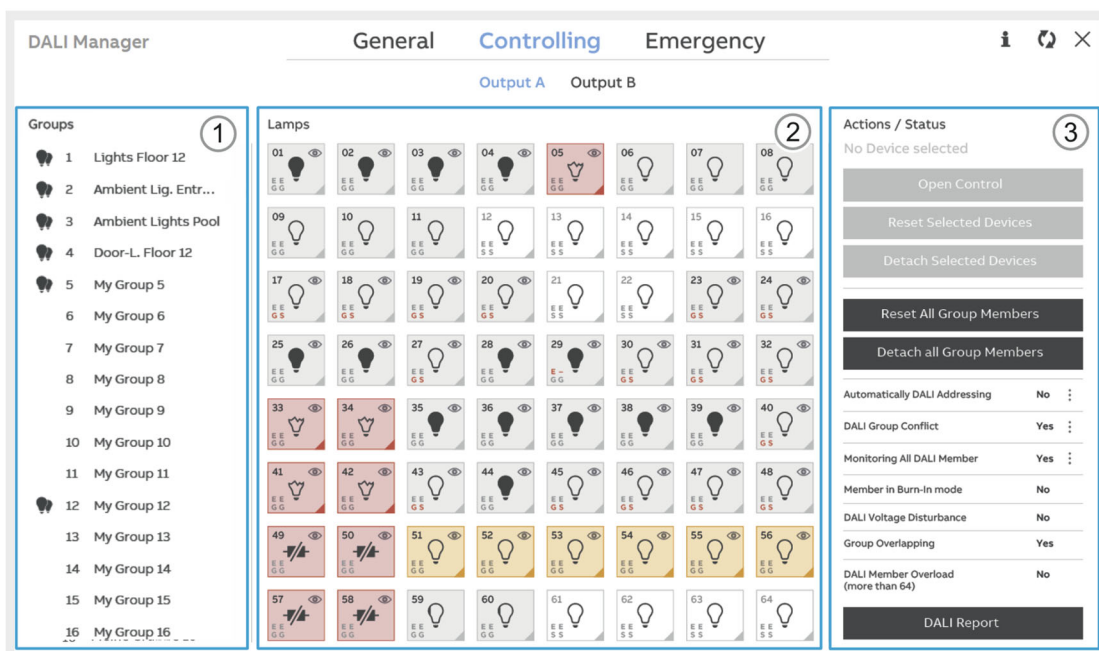

Fig. 69: DALI Manager general

Pos.	Description of functions
[1]	<p><b>License status</b></p> <p>The current status of the license can be viewed under "License status"; the status can have the following values:</p> <ul style="list-style-type: none"> <li>▪ Active</li> <li>▪ Inactive</li> <li>▪ Expires</li> </ul>
[2]	<p><b>IoT Dashboard Server Status</b></p> <p>Provides information about the general device status such as the power supply of the DALI gateway and the operating mode (manual operation blocked / active).</p>
[3]	<p><b>DALI outputs statistics</b></p> <p>Information on the current status of the DALI outputs:</p> <ul style="list-style-type: none"> <li>▪ Total number of DALI devices</li> <li>▪ Monitored devices</li> <li>▪ Faults</li> <li>▪ Lamp defect</li> <li>▪ Fault on the ballast</li> <li>▪ DALI fault</li> </ul>

[4]	<p><b>KNX connection</b></p> <p>In this area the physical address of the DALI gateway can be entered. The physical address must be entered to allow a direct connection to the gateway to be established. Only then can all additional functions be used.</p> <p>In addition, the update interval can be specified. Gateways currently supported are:</p> <ul style="list-style-type: none"><li>▪ DG/S 2.64.1.1 DALI gateway, basic, 2gang, MDRC</li><li>▪ DG/S 1.64.1.1 DALI gateway, basic, 1gang, MDRC</li></ul>
[5]	<p><b>DALI configuration</b></p> <p>Here settings for the brightness level and the switching behaviour of the DALI devices can be made.</p>

▪ **Controlling**

On the "Controlling" page DALI group members can be managed.

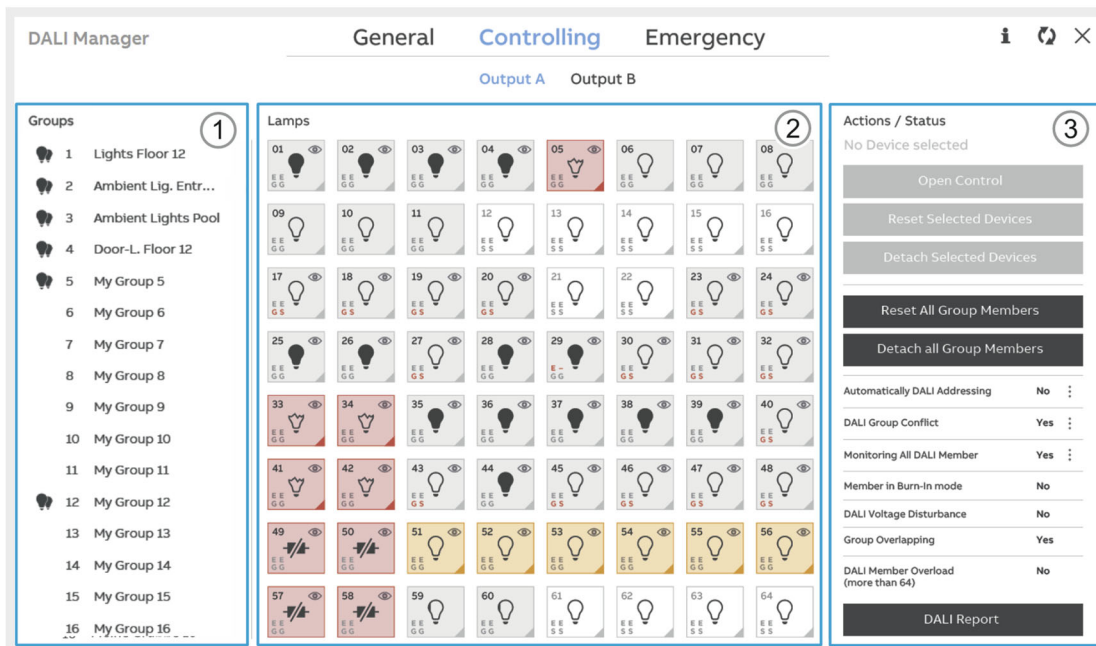

Fig. 70: Controlling

The page is divided into three areas:

Pos.	Description
[1]	<b>DALI groups</b> DALI groups can be selected by clicking or tapping. As soon as a group has been selected, all members belonging to the group are highlighted in colour.
[2]	<b>DALI members (lights)</b> DALI members can be selected by clicking or tapping. When a member has been selected, all groups containing members are highlighted in colour. DALI members can be pulled into any group via drag and drop.
[3]	<b>Actions / Status</b> In this area, general actions for the DALI groups or ballasts can be performed, such as resetting selected groups or devices.

Table 13: Controlling

**Controlling DALI ballasts or DALI groups**

1. Click/press long on a DALI group or alternatively on the "Open control" button.
  - A dialogue window opens.
2. Make all necessary adjustments (e.g. brightness value).
3. Confirm the adjustments with a click on the "Write to bus" button.

## Add DALI ballasts to groups

1. Select a DALI ballast from the members.
2. Pull the ballast into the desired group via drag and drop.
  - If the ballast is already part of the group, a dialogue window opens.
3. Confirm the enquiry with "OK".

## Reset all DALI members

1. Click on the "Reset all group members" button.
  - A dialogue window opens.
2. Confirm the enquiry with OK to reset all settings for group members.



### Notice

The action sets all DALI members back to the factory settings. All individual settings can be lost during this process.

## Detach all Group members

1. Click on the "Detach all group members" button to detach the group members.

## Create DALI report

1. Click on the "DALI report" button to create a report.
2. Specify a file format.
3. Assign a file name.
4. Specify a memory location.
5. Finally click on "Save report".



▪ **Emergency**

All relevant functions and values of all DALI emergency light converters are displayed on the "Emergency" page.

The screenshot shows the 'Emergency' tab in the DALI Manager interface. It features a table with columns for Device Num., Lighting Brightness, Auto. Test possible, Battery Charge State, Time out, Lamp Fault, Converter Failure, Reset Mode, Inhibit Mode, Last test, Test results, Test, and Action. The first row (Device 03) shows a 'Running' status in the Action column. At the bottom, there are buttons for 'Generate Report' and 'Autotest Settings'.

Device Num.	Lighting Brightness	Auto. Test possible	Battery Charge State	Time out	Lamp Fault	Converter Failure	Reset Mode	Inhibit Mode	Last test	Test results	Test	Action
03	60 %	Yes	██████	●	●	●	No	No	15.03.18	-	Fuction Test	Running
09	100 %	Yes	██████	●	●	●	Yes	No	08.03.18	OK	Fuction Test	Start
10	60 %	Yes	██████	●	●	●	Yes	No	29.10.17	OK	Fuction Test	Start
11	80 %	Yes	██████	●	●	●	Yes	Yes	29.10.17	OK	Duration Test	Start
12	80 %	Yes	██████	●	●	●	-	No	29.10.17	OK	Fuction Test	Start
14	80 %	Yes	██████	●	●	●	-	-	15.03.18	Bad	Fuction Test	Start
23	80 %	Yes	██████	●	●	●	No	No	08.03.18	-	Battery Charge State Test	Start
24	85 %	Yes	██████	●	●	●	Yes	No	11.02.18	OK	Fuction Test	Start
41	100 %	No	██████	●	●	●	Yes	Yes	15.03.18	OK	Partial Duration Test	Start
42	60 %	No	██████	●	●	●	-	No	15.03.18	OK	Partial Duration Test	Start
43	60 %	Yes	██████	●	●	●	No	No	29.10.17	OK	Fuction Test	Start
44	80 %	Yes	██████	●	●	●	No	-	29.10.17	OK	Fuction Test	Start
45	80 %	Yes	██████	●	●	●	Yes	Yes	29.10.17	OK	Fuction Test	Start
23	80 %		██████	●	●	●			08.03.18	-	Battery Charge State Test	Start

Fig. 71: Emergency

The following information, such as brightness value, charging status and device faults, are displayed. In addition, different tests can be carried out.

**Perform functional and duration test**

In the test/action area, for example, functional and duration tests can be carried out. There are four different types of tests:

- Functional test
- Duration test
- Partial duration test
- Battery charging status

Proceed as described in the following:

1. Select a device from the list for which you want to perform a functional or duration test.
2. In column "Test", specify the type of functional test or duration test you want to perform.
3. Click on the "Start" button on the right next to the "Test" column to start the test.
  - The progress is now displayed in the button.

### **Change report settings**

You can configure report settings individually; to do this, proceed as follows:

1. Click on the gearwheel symbol in the "Generate report" button.
2. Specify the file format.
3. Specify the interval (minutes, hours, etc.) at which reports are to be saved.
4. Specify a file name.
5. Specify the information that is to be attached to the file name (date, running number, time, etc.) and whether existing files are allowed to be overwritten ("Create file, also when it already exists).
6. Specify the memory location.
7. Save the settings via the "Save settings" button.

### **Generate report**

1. Click on the "Generate report" button to create a report.

### **Change auto test settings**

In the auto settings you can specify the settings for automatic tests. Here you can specify a time frame for all types of tests for the first and last test as well as a test interval.

1. Click on the "Auto settings" button.
2. Select a test type by setting a tick.
3. Change the settings.
4. Set a corresponding tick that the test is also to be started when the device is offline.
5. Set a corresponding tick to receive a message.
6. Click on "Save settings".
  - The settings are being saved.

## 10.6 System settings

An overview of the system settings can be viewed via the navigation tree:

1. Click in the ribbon bar on the "Settings" option.
  - The overall view of the system settings opens.

From the overall view a selection can be made from the different categories. These are described as follows.

### 10.6.1 User account settings



#### Notice

The "Account details", "Homepage" and "Notifications" settings are not available when you are logged in as administrator.

Setting	Function
Account details	Here general settings for the user can be stored (name, company, e-mail). Also a new password can be assigned.
Language and regions	Here the language and the country can be specified. Also the day that the week is to start can also be specified (Sunday or Monday).
Homepage	Here it can be specified which operating page of the building structure is to be displayed as homepage. Alternatively, also other areas of the IoT Dashboard, such as the favourites page, are available. <b>Notice:</b> However, it is recommended to specify the "Page visited last" as homepage, since this page enquires when exiting it whether the adjustments are to be saved.
Favourites page	Under settings you can completely delete the content of the favourites page with a click on the button "Delete page" and confirm with "Continue".
Links	In this view also the created links can be edited. The following actions can be carried out: <ul style="list-style-type: none"> <li>▪ Rename</li> <li>▪ Rearrange</li> <li>▪ Delete</li> <li>▪ Return to linked age</li> </ul>
Notifications	Under notifications you can specify for which building sections notifications are subscribed. In addition, an e-mail notification can also be set up.

## 10.6.2 IoT Dashboard Server Settings

### Connectivity



#### Notice

The "MyBuildings" settings and remote access are not available when you are logged in as administrator.

Setting	Function
MyBuildings	The connection to MyBuildings can be enabled or disabled. Adjustments are saved via the "Save" button.
Remote access	The remote connection can be enabled or disabled via the setting. Adjustments are saved via the "Save" button.
LAN 1 / LAN 2	The setting can be used to view the data of the LAN connections 1 and 2.

### Bus interfaces

The option can be used to view the different interfaces and the physical address.

### Date and time



#### Notice

If the time zone has not been correctly specified via SNTP or via the KNX bus, this can lead to faulty behaviour. For example, if when saving trend data, an incorrect time and an incorrect date are stored, this means that data are displayed in a wrong timescale.

There are three options available for the synchronisation of date and time:

1. Select one of the three following options and confirm with a click on "Save".
  - SNTP: Date and time are transmitted by the SNTP server
  - KNX bus: Date and time are transmitted by the KNX bus.
  - Manual specification: The date and time are specified by you manually.
2. When selecting the SNTP or KNX, perform a test via a click on the button next to the option.
  - Please wait while the test is being carried out.
  - After the test is concluded, a notification indicates whether the test was successful.

## 10.6.3 Data and activity logs



### Notice

The activity log is not available if you are logged in as administrator.

### Activity log

In the activity log the activities of the individual users and field buses are recorded. The following actions can be carried out in the activity log

- View activity log (of a certain timescale)
- Filtering activity log on the basis of key terms
- Delete activity log
  - With a click on the "Delete" button.
- Export activity log
  - With a click on the "Export" button.
- Enabling of gauge of the activities app
  - Set a tick at "Display activities app".

Also the activities to be displayed in the activity log can be set. For this there are three different selection options:

- "Display only my activities"
- "Display only the activities of my group"
- "Filter the display of the user group / user account"

### 10.6.4 Development

The use of rest APIs can be enabled or disabled via the "Development" option.

Also the services of third-party suppliers can be integrated in the IoT Dashboard.

#### Create new API token

1. Click on API Client 2 under "Development".
2. Click on the plus sign next to "Services".
  - A menu opens in which the necessary configurations can be made and the API token can be generated.
3. Assign the necessary rights.
4. Generate the token with a click on "Generate API token".

The following rights can be assigned:

- Display and manage users
- Display and manage notifications
- Display and edit architectural elements
- Display architectural elements
- Operate with controls / objects
- Display and manage user administration
- Manage configuration of the IoT Dashboard
- Display activity log

#### Delete API token

1. Click on API Client 2 under "Development".
2. Click on "Delete API token".
3. Confirm the action.
  - The token is deleted.

#### Integrating Cloud services

1. Click on "Cloud services" under "Development".
2. Enter either the stated code, or scan the QR code to connect your services with the IoT Dashboard.

## 10.6.5 Update und backup

The software version used can be viewed and updated under "Update and backup", and backups can be created.

### Performing update

In case of available backups the different software components can be updated.

Updates are possible for:

- IoT Dashboard
- Update plugins (not available in Version 1)
- Update applications (not available in Version 1)
- Update controls (not available in Version 1)

Updates are performed as follows:

1. Open the software component to be updated, e.g. "IoT Dashboard".
2. Click on the "Update" button.
  - The update is being carried out.

### Create backup

Backups can be performed under the "Backup" option.

Create a backup as described in the following:

1. Open the "Create" option in the "Backup" area.
2. Assign a file name under "Filename".
3. Select where the file is to be saved under "Memory location".
4. Click on the "Create backup" button.
5. If necessary, encrypt the file with the aid of a password.
6. Click on "Save" and save the file.
  - If you have created a local backup, you will then be requested to select a memory location on your device.



#### Notice

The backup can only be encrypted after the creation has been completed.

### Restore system

The system can be restored as described in the following:

1. Open the "Restore" option in the "Backup" area.
2. Select the backup file.
3. Enter the correct password.
4. Click on "Load backup file".
  - The system is restored on the basis of the backup file.

## 10.6.6 Device information

All device information can only be viewed in the read access. The user cannot make any adjustments. The following device information can be viewed.

- Interfaces status
- User accounts
- Trend recordings
- Internal memory recordings
- PCBs
- System integrator
- Manufacturer
- Legal documents
- About the software



# 11 Update

## 11.1 Firmware update

There are three options for updating the firmware of the IoT Dashboard Server. These options for updating the firmware of the IoT Dashboard Server are described in the following:

### Upgrade via IoT Dashboard Tool

1. In the "Project" tab, click on the "Upgrade..." button.
  - The "IoT Dashboard Server Upgrade" menu opens.
2. Enter the IP address of the IoT Dashboard Server under "Address".
3. Select between the following two options:
  - "Use local upgrade file":
    - The upgrade is carried out via a local update file on your computer.
  - "Use Cloud upgrade":
    - The upgrade is carried out via Cloud (not yet supported in Version 1).
4. If you perform the upgrade via a local update file, enter the file path under "File".
5. Enter the upload password you specified in the settings.
6. Click on "Upgrade".



#### Notice

If you do not know the IP address of the device, you can search for connected devices under "Found IoT Dashboard Server" with a click on "Scan".



#### Notice

You can view the release notes on the current firmware version with a click on the "Release Notes" button.

### Upgrade via IoT Dashboard

1. Click on the Burger menu to open the ribbon bar.
2. Click on the gearwheel symbol to open the settings.
3. In the settings click on the "Update and backup" menu.



#### Notice

If an update is available, this is indicated by means of a blue mark next to the menu. The mark disappears as soon as the update process starts.

4. Select the IoT Dashboard option from the available options under Updates.
5. Click on "Update".
  - The update process starts.



#### Notice

Available updates are also displayed in the notification center. You enter the update and backup menu with a click on notification. The progress of an update is displayed in the notification center.

### Upgrade via SD card

You can also load an update file on the IoT Dashboard Server via an SD card. To do this, proceed as follows:

1. Download the current firmware from the electronic catalogue ([www.busch-jaeger-catalogue.com](http://www.busch-jaeger-catalogue.com)).
2. Pull a firmware image onto the compatible SD card.
3. Plug the micro-SD card into the SD slot of the IoT Dashboard Server.
  - The device recognises the micro-SD card and starts the update.
  - The update is completed after approx. 10 minutes and the device performs a reboot. The update is active after the reboot.



#### **Notice**

The successful update is displayed in the IoT Dashboard by means of changed version information.

## 12 Legal information

### 12.1 End User Licence Agreement

An end user license agreement is an agreement between ABB and its customers for the use of the software to which you have the rights. It enables the customer to use the software and provides information for its use.

Within the scope of the end user license agreement it is described where, how and how often you are permitted to install the software. It also answers questions about duplication, modification and transfer of the software.

#### 12.1.1 License text ABB i-bus® KNX IoT Dashboard Tool

##### Terms for IoT Dashboard Tool

**- for commercial transactions between businesses only -**

**IMPORTANT – READ CAREFULLY:** This license agreement is a legal agreement between commercial end-user (either an individual or a single entity, but no consumer), as licensee, and Busch-Jaeger Elektro GmbH, Lüdenscheid, Germany for IoT Dashboard Tool.

LICENSEE AGREES TO BE BOUND BY THE TERMS OF THIS LICENSE AGREEMENT, including any amendment or addendum. IF LICENSEE DO NOT AGREE, DO NOT INSTALL OR USE THE SOFTWARE.

*In view of the software these Special Terms and Conditions and, supplementarily, the General Terms of Use shall apply.*

#### 0. Scope

In addition to, and with priority over, the General Terms of Use as attached to this document (“Terms of Use”), these Special Terms and Conditions shall apply to the licensing of the IoT Dashboard Tool (which includes IoT Dashboard and user interface to ETS software).

These Special Terms and Conditions shall apply, insofar as the scope of application is not restricted by provisions in the Contract (which comprises of (i) these Special Terms and Conditions and (ii) the Terms of Use).

The Software is available for non-consumers ONLY.

– hereinafter: “Software”.

Licensee shall not be entitled to use the Software prior to entering into the Agreement and complete payment of the fee as provided herein. The terms for the using of the Software shall be hereinafter laid down:

#### 1. System Requirements

The use of the IoT Dashboard Tool requires additional hardware and software components of the IoT Dashboard solution as described in the product manual for IoT Dashboard Tool . The Software shall only be used within the IoT Dashboard system.

## **2. License; Back-up Copy; Updates**

The license in the Software is free of charge. Thus the provisions of the Terms of Use for Pilot Services apply.

You are entitled to make a single backup copy of the IoT Dashboard Tool solely for security purposes. This copy shall be and is subject to the same restrictions as the downloaded Software. You shall refrain from removing an existing copyright notice from the Software.

You shall impose the terms of the Contract on each and every third party to which you will make the Software (code) available, imposing that such third party shall be under the same obligation.

Following receipt of information that an update or upgrade of the Software is available, Licensee will download and install such update or upgrade versions without undue delay and use the updated or upgraded Software only.

## **3. Coming into Force and Term of the Contract**

The Contract and, hence, the license shall come into force upon downloading the Software and shall have an unlimited term (subject to termination as per the terms of the Contract).

## **4. Secure Systems**

Insofar as deliveries include products (including software) that are designed to be connected to and communicate information and data via a network interface, it is your sole responsibility to establish and maintain a secure connection between the product, your network or, where relevant, a different network. Section 3.3 of the Terms of Use shall also apply in view of the products provided.

+++++++

**GENERAL TERMS OF USE (“TERMS OF USE”)**

**THESE TERMS OF USE CONTAIN VERY IMPORTANT INFORMATION REGARDING YOUR RIGHTS AND OBLIGATIONS, AS WELL AS CONDITIONS, LIMITATIONS, AND EXCLUSIONS THAT MIGHT APPLY TO YOU.**

**BY PLACING AN ORDER FOR SERVICES THAT REFERS TO THESE TERMS OF USE, YOU AGREE TO BE BOUND BY THE TERMS AND CONDITIONS SET OUT HEREIN.**

**YOU MAY NOT OBTAIN PRODUCTS, SOFTWARE OR SERVICES FROM US IF YOU (A) DO NOT AGREE TO THESE TERMS OF USE, (B) ARE NOT THE OLDER OF (i) AT LEAST 18 YEARS OF AGE OR (ii) LEGAL AGE TO FORM A BINDING CONTRACT WITH THE ABB ENTITY IDENTIFIED ON YOUR ORDER FORM, OR (C) ARE PROHIBITED BY APPLICABLE LAW FROM ACCESSING OR USING ANY CONTENT, PRODUCT OR SERVICE MADE AVAILABLE TO YOU BY US.**

**1 Scope and contract formation**

1.1 Parties and scope. The terms and conditions contained in these Terms of Use (“Terms of Use”) together with any Special Terms and Conditions (“STC”), if any, Order and other terms and conditions referred to in these Terms of Use (together, the “Contract”) are agreed between the ABB entity (“ABB”, “we”, “us” or “our”) and the contracting entity (“Customer”, “you” or “your”) indicated in the Order. The Contract governs our provision and your use (if any) of the Services and Software as well as your access to the Platform (each as defined below).

1.2. Authority. If you are accepting this Contract on behalf of any third party (including any other Users), you represent and warrant that you are authorized to grant all permissions and licenses provided in these Terms of Use and to bind all such third parties with respect to the subject matter hereof.

**2 Services and Software**

2.1 Pilot Services. Where we provide Pilot Services, these are subject to additional limitations as set out in this Section 2.3 which shall prevail over other provisions of these Terms of Use. Pilot Services are free of charge, except as specified otherwise in the Order. You understand and acknowledge that Pilot Services may not have been fully tested or verified, may become unavailable, that their performance may be negatively affected, and/or that the Pilot Services may not meet industry practice security standards and might therefore negatively affect your internal procedures and business operations or impair the functionalities of your systems or devices. You may use the Pilot Services only for your internal use for the purpose of reviewing, evaluating and testing the Pilot Services. Use of the Pilot Services is at your sole risk. We may, at our sole discretion, (i) modify the Pilot Services or features of the Pilot Services; (ii) provide up-upgrades, patches or maintenance; or (iii) terminate, limit, suspend or discontinue the Pilot Services or access to the Pilot Services. Our liability for all claims, damages, loss and indemnities arising out of or in connection with the Pilot Services is limited to direct damages and, in aggregate, to the amount of USD 100 (one hundred). Other than the limited liability, set out in the preceding sentence, we provide the Pilot Services "as is" without any warranties and excluding all liability to the fullest extent permitted under applicable Laws. **THE PILOT SERVICES ARE PROVIDED ON AN “AS IS” AND “AS AVAILABLE” BASIS, WITHOUT ANY WARRANTIES AND EXCLUDING ALL LIABILITY TO THE FULLEST EXTENT PERMITTED UNDER APPLICABLE LAW. USE OF THE PILOT SERVICES IS AT YOUR SOLE RISK.**

2.2 **External Items, Hardware and Services.** You are responsible for obtaining access to the Platform Services, and you acknowledge that such access and your use of the Service may involve third-party products or services. We do not operate or control any third party products, services, websites, software, applications, app stores or any other material, information, software, services, opinions or other content provided by third parties, including on the internet (collectively, "**External Items**"). Use of External Items is subject to your acceptance of the applicable third party terms of use and your payment of any applicable third-party fees, and you acknowledge and agree that any contractual relationship related to External Items is solely

between you and the provider of such External Items. We make no warranties or representations and we have no obligation, responsibility or liability for External Items and your use of External Items to the extent permitted by Laws. You waive any right or claim of right against us relating to External Items.

**2.3 Changes to the Services or Software.** We may make any reasonable changes to the Services and/or Software from time to time that do not materially adversely affect the nature, quality or security of the Services and/or the Software. We may change the Services and/or Software, even if such change does materially adversely affect its nature, quality or security, or discontinue a Service and/or the provision of the Software only if (i) necessary to comply with any applicable Laws or safety or security requirements; or (ii) there are material changes caused by a subcontractor or the termination of a material subcontractor relationship. We will notify you of any change with a material adverse effect or of any discontinuation of a Service and/or provision of a Software. In such case, you may terminate the affected Service within 30 (thirty) days following notification with 30 (thirty) days written notice and we will refund you any prepaid amounts for the respective Service on a pro-rata basis for the remainder of the Service term. Such refund is your sole and exclusive remedy. By continuing to use a changed Service and/or Software despite the notification and beyond the 30 days termination period, you agree to the respective change. It is in our sole discretion whether we maintain providing prior versions of a Service and/or Software for a certain time period and we will notify you if we do maintain providing prior versions of the Service and/or Software.

**2.4 ABB Software.** Subject to the terms and conditions of the Contract, we hereby grant you a non-exclusive, non-transferable, time limited license to use the ABB Software for the Service period set out in the Order for your personal or internal business purposes of receiving the Services. We may remotely install updates or up-grades to the ABB Software with or without notice. Updates or upgrades shall be governed by the terms and conditions of the Contract unless such updates or upgrades are accompanied by a separate license provided by us in which case the terms and conditions of such separate license will take precedence over other documents forming the Contract with regards to any conflicting terms. Notwithstanding the foregoing, except to the extent specifically set out otherwise in the Order or STC, we are not obliged to provide any updates or upgrades to the ABB Software.

**2.5 Third Party Software.** Except to extent explicitly specified otherwise in the STC or the Order, for all Third Party Software, the terms and conditions of use of the third party licensor apply exclusively and you acknowledge and agree that (i) any contractual relationship related to your use of such Third Party Software is solely between you and the provider of such Third Party Software; (ii) it is your own responsibility to assess the accuracy of using such Third Party Software; and (iii) we make no warranties and will have no responsibility or liability related to your use of such Third Party Software, to the extent permitted by applicable Laws.

### 3 Data protection and security

**3.1 Data protection.** Each party shall comply with all applicable Laws related to the protection of Personal Data and agrees not to withhold or delay its consent to any changes to applicable contract provisions in order to comply with such applicable Laws and orders from any competent authority. We will further comply with our Data Privacy Policy, applicable from time to time, when using such Personal Data. The parties acknowledge that the processing of Personal Data may require the conclusion of additional data processing/protection agreements. A party shall, upon request of the other party, promptly enter into any such agreement(s) as required by mandatory law or a competent authority.

**3.2 License verification.** Devices on which ABB Software is installed may automatically provide information to us to enable verification that it is properly licensed. Such information includes information about the ABB Software, the user account, product ID information, a machine ID, and the internet protocol address of the device. By using the ABB Software, you consent to the transmission of such information and our use of such information in accordance with the Contract.

## 4 Your responsibilities

**4.1 General obligations.** You will: (i) obtain and maintain all necessary licenses, permissions, filings and consents (which shall include consent of individuals where you provide Personal Data to us) which may be required regarding Your Content, software and other content, if any, provided by you in connection with the Services and your accounts associated with the Platform; (ii) when using External Items, comply with the respective terms and conditions of use and the license terms and conditions in connection with External Items; (iii) without undue delay, completely and accurately install the necessary Software and any updates or upgrades provided by us (in accordance with the respective specification and instructions) on your computer systems and/or mobile devices (as applicable); (iv) comply with any restrictions on permitted User types; (v) comply with our reasonable instructions regarding the proper use of the Services and/or Software as may be given in individual cases from time to time; (vi) ensure that all Users comply with these Terms of Use and the terms and conditions of the Acceptable Use Policy; and (vii) comply with all applicable Laws, in particular when providing Your Content. You will not use the Services or Software (i) for any part of any nuclear facility; or (ii) in any application or situation where failure of the Services or Software could lead to the death or serious bodily injury of any person, or to severe physical or environmental damage.

**4.2 Cooperation and information obligations.** You will reasonably co-operate with us in all matters relating to the Services and/ or the Software and provide us with such information and materials as we may reasonably require in order to provide the Services and/or the Software, to perform maintenance or bug fixing, as well as in order to verify your compliance with the Contract.

**4.3 Monitoring of usage and remote connection.** The provision of Services and/or the Software may require us to monitor your usage of the Services, Platform and Software as well as the establishment of a remote connection between the Platform and certain systems. Except to the extent explicitly specified otherwise in the STC or the Order, you will (i) establish and maintain such remote connection with appropriate connectivity; (ii) permit us, our employees, our Affiliates, agents, consultants and/or subcontractors, to remotely access and monitor your usage of certain systems owned, controlled or operated by or on behalf of you, as necessary for us to provide the Services; and (iii) install and maintain any hardware, software, or other equipment necessary to establish and maintain the monitoring and/or remote connection.

## 5 Charges and payment

**5.1 Payment terms.** In consideration for the provision of the Services and/or the Software, you will pay the charges as set out in the Order. You will pay all invoiced amounts due under the Contract within 30 (thirty) days from the date of the invoice in full without any set-off, deduction or with-holding. Late payment interest of 1.5% per months or, if such rate is not permitted, the highest rate permitted under applicable Law will be charged in case of late or incomplete payment.

**5.2 Taxes and customs.** Our charges are net, i.e. without taxes or other transaction levies. You are responsible for the payment of (i) any value added tax, sales tax, customs fee or other transaction levies as applicable; and (ii) any withholding taxes that either party must pay arising from inter-national transactions. If you are exempt from the payment of any taxes, you must provide us with a valid tax exemption certificate or proof of your direct payment of taxes to the applicable tax authority; otherwise you must pay to us all such taxes. Subject to the foregoing, we will be solely responsible for all taxes based on our income.

## 6 Proprietary rights

**6.1 Your Content.** We will not acquire any right, title and interest in Your Content other than the rights you grant to us under the Contract. During the term of the Contract, you will have the ability and the right to access and extract some or all of Your Content if and to the extent specified in the STC or the Order.

**6.2 ABB Content.** As between the parties, all right, title and interest, including all Intellectual Property Rights, in and to the ABB Content are and remain exclusively with us, our Affiliates or our licensors. You have no rights in and to the ABB Content, other than those expressly granted pursuant to the Contract.

**6.3 Our use of Your Content.** We, our Affiliates and our subcontractors have the right to collect, store, aggregate, analyze or otherwise use Your Content for purposes of (i) providing and maintaining the Services and/or the ABB Software to you; (ii) preventing, detecting and repairing problems related to the security and/or the operation of the the Platform, the Services and/or the ABB Software; (iii) improving and developing existing services, technologies, products and/or software and developing new services, technologies, products and/ or software. For the avoidance of doubt, all such improvements and developments (including all resulting Intellectual Property Rights) are exclusively owned by us and to the extent any rights therein vest in you, you hereby irrevocably assign all such rights to us. In addition, we have the right to use Your Content for benchmarking purposes if and to the extent it is anonymized or non-confidential.

**6.4 Feedback.** During the term of a Contract, you may provide feedback or suggestions related to the Services, the Software, the Platform to us. We and our Affiliates are entitled to use such feedback and suggestions, even if they should be marked confidential (see Section 14.1), without any restrictions and any compensation to you.

**6.5 Restrictions.** You will not in whole or in part (i) (except as explicitly permitted in an Order, these Terms of Use or the STC) use the ABB Content in any manner, including for any third-party use including license, sublicense, sell, resell, lease, transfer, assign, distribute, display, broadcast, disclose, or other-wise commercially exploit or make it, or any portion thereof, available to any third party in any manner; (ii) tamper with or repair the ABB Content; (iii) copy, reproduce, publish, reverse engineer, attempt to derive the source code of, modify, dis-assemble, decompile or create derivative works of the ABB Content (except to the extent that applicable Laws prohibits reverse engineering restrictions, and then only as permitted by such laws); (iv) copy any ideas, features, functions or graphics of the ABB Content; (v) access or use the ABB Content in a way to avoid incurring fees or exceeding usage limits or quotas or to circumvent or render inoperative any usage restriction features contained in ABB Content; ; (vi) use any data mining, bots, spiders, automated tools, or similar data gathering and extraction methods on the contents of the ABB Content or to collect any information from the ABB Content or any other User, and/or (vii) remove, obscure, alter, or move our and our licensors' proprietary notices. Use of the ABB Content other than specifically permitted in the Contract, is expressly prohibited.



## 7 Intellectual property infringement

**7.1 Defense and indemnity.** If any third party makes a claim against you that the Services or the ABB Software infringe a third party's copyrights, patents or trademarks (a "**Claim**"), we will defend you against such Claim and pay the amounts finally awarded by a court against you or included in a settlement approved by us, provided that you will (i) give written notice of the Claim to us without undue delay, specifying the nature of the Claim in reasonable detail; (ii) not make any admission of liability, agreement or compromise in relation to the Claim without the prior written consent of us; and (iii) allow us to control and reasonably cooperate with us in the defense and settlement of the Claim.

**7.2 Effect of Claim.** If a Claim is made or, in our reasonable belief, is likely to be asserted, we may, at no cost to you: (i) procure for you the right to continue to use the ABB Software, or continue to take the benefit of any Services, that are affected by the Claim in accordance with the terms of the Contract; or (ii) modify or replace the infringing ABB Software or re-perform the applicable Services so that it becomes non-infringing (provided that the modified or replaced ABB Software or the re-performed Services, provide substantially the same performance and functionality and do not adversely affect the use of the Services or ABB Software); or (iii) if the remedies set forth in Sections 7.2(i) and 7.2(ii) are not commercially feasible, as determined by us in our sole discretion, terminate the applicable Order, in whole or in part, and pay you a pro rata refund of the fees paid by you for the infringing Service or ABB Software.

**7.3 Exceptions.** We have no liability or obligation related to any Claim if and to the extent the Claim arises out of or relate to (i) the use of Your Content; (ii) a modification of the Services and/or Software created by or at the direction of you or a third party; (iii) use of the Services or ABB Software other than in accordance with the terms of the Contract; (iv) use of the Services or ABB Software in combination with any other hardware, software or other materials, where absent such combination, the affected Service or ABB Software would not be the subject of a Claim; (v) use of a version of the ABB Software for which we have provided updates or upgrades and you have not or not without undue delay, completely and accurately updated or upgraded the ABB Software; or (vi) any Third-Party Software.

**7.4 Sole and exclusive remedy.** This Section 7 states the sole, exclusive and entire liability of us to you and your sole and exclusive remedy with respect to any claim or allegation of infringement or misappropriation of any third party Intellectual Property Right.

## 8 Warranty and indemnity by you

**8.1 Warranty.** You represent and warrant that the use by us of Your Content or your grant of any license or right under the Contract, will not infringe the Intellectual Property Rights or other rights of any person.

**8.2 Indemnity.** You will indemnify, defend and hold harmless ABB and our Affiliates, suppliers, licensors, subcontractors as well as our and their respective directors, officers, employees and representatives, from and against all costs, claims, demands, liabilities, expenses, damages or losses (including without limitation reasonable attorneys' fees) arising out of or in connection with (i) your use of or reliance on any ABB Content; (ii) violation of any third party's rights related to Your Content or its use by us, our Affiliates and/or our subcontractors in accordance with the Contract; (iii) your breach of the Contract; and (iv) breach of Laws, in each case except to the extent such claim results from our gross negligence or willful misconduct. We will provide notice to you without undue delay of any such claim. We reserve the right to assume the exclusive defense and control of any matter subject to indemnification by you, in which event you will assist and cooperate with us in asserting any available defenses. In any event, you shall not settle any such claim without our prior written approval.

## 9 Warranties by us

**9.1 Services warranty.** We warrant that we (i) provide the Services or make the Services available to you using commercially reasonable care and skill and in accordance with the description set out in the Order and the STC in all material respects; and (ii) will apply commercially reasonable measures to maintain availability of the Services; however, subject to unavailability or temporary disruption of the Services due to operational measures (such as scheduled or emergency maintenance), security measures, connectivity or data transmission failure, unlawful or unauthorized acts of third parties, or other reasons that are beyond our control. If you allege that a Service is not performed consistent with this services warranty, you must notify us without undue delay, after becoming aware of the defect or having the possibility to gain knowledge of the defect but in no event later than 14 days thereafter, in writing about the defect in reasonable detail and, if we are able, by application of commercially reasonable effort, to reproduce and verify the defect, we will use commercially reasonable efforts to rectify the defect or, if the defect is of the nature of unavailability of Services, restore the Services which were not performed as warranted.

**9.2 Software warranty.** We warrant that the ABB Software will perform in accordance with the description set out in the Order and/or the STC in all material respects for a period of three (3) months following delivery of the ABB Software to you. If you allege that the ABB Software does not perform consistent with this ABB Software warranty, you must without undue delay, and in any event prior to the end of the ABB Software warranty period specified above in this Section 9.2, notify us in writing about the defect in reasonable detail and, if we are able, by application of commercially reasonable effort, to reproduce and verify the defect, we will use commercially reasonable efforts to provide corrections of, or avoidance procedures for documented deviations from this ABB Software warranty. Warranties related to any Third Party Software, if any, are specified in the agreement between you and the provider of such Third Party Software. We do not provide any warranty related to Third Party Software.

**9.3 Limitations.** The warranties set out in this Section 9 shall not apply: (i) if the ABB Software is not used in the contemplated environment, or in accordance with its specification or the Contract; (ii) if the Services or the ABB Software has been installed, implemented, customized, modified, enhanced or altered by you or any third party; (iii) if you are not using the most recent version of the ABB Software and the defect has been remedied in the newer version; (iv) to any error or defect caused by you, any third party, or any Third Party Software, or Force Majeure according to Section 16.1; or (v) to any error or defect arising as a result of drawings, designs or specifications provided by you. Product descriptions shall not be deemed warranties unless separately agreed in writing.

**9.4 DISCLAIMER.** EXCEPT AS OTHERWISE EXPRESSLY PROVIDED HEREIN, WE PROVIDE THE ABB CONTENT OR THIRD PARTY SOFTWARE, SERVICES OR SOFTWARE TO YOU ON AN “AS-IS” BASIS WITHOUT WARRANTY OF ANY KIND , WITHOUT MAINTENANCE OR ANY SUPPORT SERVICES AND SOLELY FOR THE PURPOSE CONTEMPLATED IN THE CONTRACT. EXCEPT AS EXPRESSLY SPECIFIED IN THE CONTRACT, WE MAKE NO REPRESENTATIONS OR OTHER WARRANTIES OF ANY KIND, AND WE DISCLAIM ALL WARRANTIES AND REPRESENTATIONS WHETHER EXPRESS, IMPLIED, STATUTORY OR OTHERWISE WITH RESPECT TO THE ABB CONTENT OR THIRD PARTY SOFTWARE, SERVICES OR SOFTWARE INCLUDING, WITHOUT LIMITATION, ANY WARRANTY THAT THE SERVICES OR SOFTWARE WILL BE SECURE, UNINTERRUPTED AVAILABLE, ERROR FREE OR FREE OF HARMFUL COMPONENTS, , ANY INFORMATION THAT MAY BE OBTAINED THROUGH THE ABB CONTENT OR THIRD PARTY SOFTWARE WILL BE ACCURATE OR RELIABLE, ANY ERRORS IN THE SITE OR SERVICE WILL BE CORRECTED, INCLUDING ANY IMPLIED WARRANTIES OF MERCHANTABILITY, FITNESS FOR A PARTICULAR PURPOSE, SATISFACTORY QUALITY, NON-INFRINGEMENT, QUIET ENJOYMENT, AND ANY WARRANTIES ARISING OUT OF ANY COURSE OF DEALING OR USAGE OF TRADE. TO THE EXTENT PERMITTED BY LAW, THE LIMITED WARRANTIES SET FORTH IN THIS SECTION 9 ARE YOUR EXCLUSIVE WARRANTIES AND THE REMEDIES SET OUT IN SECTIONS 9.1 AND 9.2 ARE THE SOLE AND EXCLUSIVE REMEDY FOR ANY BREACH TO THE RELEVANT WARRANTIES.

**\*\*YOU EXPRESSLY AGREE THAT ANY MATERIAL DOWNLOADED, VIEWED OR OTHERWISE OBTAINED THROUGH THE USE OF THE ABB CONTENT OR THIRD PARTY SOFTWARE IS DOWNLOADED, VIEWED OR USED AT YOUR OWN DISCRETION AND RISK AND YOU WILL BE SOLELY RESPONSIBLE FOR ANY DAMAGE TO COMPUTER SYSTEMS AND NETWORKS OR LOSS OF DATA THAT RESULTS FROM THE DOWNLOAD, VIEWING OR USE OF ANY SUCH MATERIAL.**

## 10 Limitation of liability

**10.1 Limited liability.** Subject to Sections 10.2 and 10.3, our total aggregate liability, whether in contract, tort (including negligence), breach of statutory duty, or otherwise, arising under or in connection with these Terms of Use or a Contract based on these Terms of Use shall be limited to the lower of (i) a sum equal to the charges paid for the specific Service or Software giving rise to the claim in the 12 (twelve) months prior to the date on which the claim arose; and (ii) the value of the specific Contract.

**10.2 Exclusions.** We shall not be liable, whether in contract, tort (including negligence), breach of statutory duty, or otherwise, arising under or in connection with a Contract, and even if we have been advised of the possibility of such damages, for (i) loss of profits, sales or business, agreements or contracts, anticipated savings, revenue, or damage to goodwill; (ii) business interruption, loss of production, loss of use or loss or corruption of data; (iii) costs of substitute goods, materials or services; or (iv) any indirect, consequential, incidental, special, punitive damages or exemplary loss.

**10.3 Scope of limitations and exclusions.** The limitations and exclusions of liability also apply to the benefit of our Affiliates, suppliers, licensors, subcontractors as well as our and their directors, officers, employees and representatives. You may not assert any claim for breach or non-performance under a Contract against us, whether in contract, tort (including negligence), breach of statutory duty, or otherwise, unless you have given us written notice of the claim within 1 (one) year after you first knew or reasonably should have known of the facts giving rise to such claim. For the provision of Pilot Services Section 2.3 applies. The limitation and exclusions to our liability in Sections 10.1 and 10.2 do not apply for: (i) death or personal injury caused by our acts or omissions; (ii) gross negligence, willful misconduct, fraud or fraudulent misrepresentation; or (iii) any other liability which cannot be limited or excluded by applicable Laws. The limitations and exclusions of liability also apply to the benefit of our Affiliates, suppliers, licensors, subcontractors as well as our and their directors, officers, employees and representatives.

## 11 Suspension

We may suspend the Services in whole or in part if we determine that your use of the Services (i) poses a security risk to the Services, the Platform and/or any third party; (ii) may adversely impact the performance of the Services, the Software, Platform ; (iii) is in violation of the Laws or poses a risk that we are or will be in violation of the Laws; (iv) may subject us or any third party to liability. In addition, we may suspend the Services under the circumstances specified in the Acceptable Use Policy and if you fail to pay any amount due under the Contract on the due date for payment. We will suspend the Services only to the extent reasonably necessary. Unless we believe an immediate suspension is required and appropriate, we will use commercially reasonable efforts to provide reasonable notice before suspending a Service.

## 12 Term and termination

**12.1 Term.** A Contract will enter into effect as described in Section 1.2 above and will remain in effect for a period as set out in STC or the Order or as terminated earlier in accordance with the Order, the STC or Sections 12.2, 12.3 or 12.4 below.

**12.2 Termination for convenience.** Either party may terminate a Contract for convenience if and as set out in the STC or the Order.

**12.3 Termination for cause by each party.** Without limiting its other rights or remedies, either party may terminate the Contract with immediate effect by giving written notice to the other party if the other party is in material breach of the Contract and, where the breach is by its nature curable, a breach is not cured within 30 (thirty) days, or such other period which is reasonably required considering the circumstances, following notification of the breach by the non-breaching party. If the breach is not capable of cure, the non-breaching party may terminate the Contract with immediate effect upon first notice of the breach.

**12.4 Termination for cause by us.** Without limiting our other rights or remedies, we may also terminate the Contract (in whole or in part) with immediate effect by giving written notice to you if (i) you fail to pay any amount due under the Contract on the due date for payment and remain in default not less than 14 (fourteen) days after being notified to make such payment; (ii) there is a change in the Laws in one or more countries applicable to the performance of the Service that would render the continued performance of the Service illegal, impractical or would otherwise have a material impact (including a cost impact) on the provision of the Services; (iii) a suspension of the Services as per Section 11.1 exceeds a period of 14 (fourteen) days; or (iv) you are in breach of the Acceptable Use Policy or the license terms.

**12.5 Effect of termination or expiration.** Upon termination or expiration of the Contract for any reason: (i) you will immediately cease using the Services and, where a Software license terminates or expires, uninstall all affected Software from your devices and computer systems, and cease use of such Software; and (ii) the accrued rights, remedies, obligations and liabilities of the parties as at termination or expiration shall be unaffected, including the right to claim damages in respect of any breach of the Contract which existed at or before the date of termination or expiration. The Order or the STC may set forth your responsibilities, applicable means and timeframes for retrieving Your Content upon or after termination or expiration of the Contract.

## 13 Export control or sanctions

**13.1 Export control and sanctions.** You will not export, directly or indirectly, any product, software or technical data acquired from us under the Contract in breach of any applicable export control or sanctions laws, including, if applicable, those of the United States, and you will obtain any export licenses or other government approvals required for such exports. In addition, if requested by us, you will provide us with any reasonable assistance that is necessary for us to perform any activity required by government authorities, or otherwise to comply with export control or sanctions laws.

**13.2 Third parties.** You will contractually oblige any third party to whom you might disclose, transfer or export products, software or data that you procure pursuant to a Contract to comply with export control and sanctions requirements equivalent to those in Section 13.1.

## 14 Confidentiality

**14.1 Confidentiality.** Each party agrees to use the same standard of care as it uses with its own similar confidential information, however, such standard to be at least a reasonable standard of care, to avoid disclosure to any third party on any technical or commercial knowhow, specifications, inventions, processes, code, product plans, marketing plans or initiatives or any other information or data which are designated at the time of disclosure to the Recipient as confidential or are recognizable as being of a confidential nature and have been disclosed to such party (the "**Recipient**") by the other party (the "**Discloser**") or its agent, except as permitted by Sections 6.4 and 14.3.

**14.2 Exceptions.** Confidential information does not include any particular information that the Recipient can reasonably demonstrate (i) was in the possession of, or was rightfully known by, the Recipient without an obligation to maintain its confidentiality prior to receipt from the Discloser; (ii) was or has become generally available to the public other than as a result of disclosure by the Recipient or its agents; or (iii) was independently developed by the Recipient without use of or reference to any confidential information of the Discloser.

**14.3 Permitted disclosure.** The Recipient may use the Discloser's confidential information for the purpose of performing the Contract or as otherwise permitted by the Contract and disclose it (i) to such of its and its Affiliates employees, agents, professional advisers or subcontractors as need to know the same in connection with the Contract and provided the Recipient takes reasonable measures to ensure that such employees, agents or subcontractors comply with this Section 14; and (ii) as may be required by Laws, a court of competent jurisdiction or any governmental or regulatory authority, provided that the Recipient takes reasonable efforts to notify the Discloser (where legally permissible to do so) reasonably in advance to enable the Discloser a reasonable opportunity to obtain a protective order.

**14.4 Duration.** For 5 (five) years after the initial disclosure, the Recipient agrees to apply reasonable safeguards against the unauthorized disclosure of the Discloser's confidential information in accordance with good industry practice, or in the same manner and to the same degree that it protects its own confidential and proprietary information – whichever standard is higher.

## 15 Governing Law and Jurisdiction

Unless and to the extent otherwise prescribed in Section 18, the following provisions shall apply:

**15.1 Governing law.** The Contract, and any dispute or claim (including non-contractual disputes or claims) arising out of or in connection with it or its subject matter or formation shall be governed by, and construed in accordance with the substantive **laws of Switzerland** excluding both its conflict of laws provisions and the United Nations Convention on Contracts for the International Sale of Goods (Vienna, 1980).

**15.2 Jurisdiction.** Any dispute, controversy or claim arising out of, or in relation to, the Contract, including the validity, invalidity, breach, or termination thereof, shall be resolved by arbitration in accordance with the **Swiss Rules of International Arbitration of the Swiss Chambers' Arbitration Institution** in force on the date on which the notice of arbitration is submitted in accordance with these rules. The number of arbitrators shall be three. The seat of the arbitration shall be Zurich. The arbitral proceedings shall be conducted in English.

## 16 General provisions

**16.1 Force majeure.** Neither party shall be in breach of the Contract nor liable for delay in performing, or failure to perform, any of its obligations under the Contract if such delay or failure result from events, circumstances or causes beyond its reasonable control, including: (i) acts of God, flood, fire, earthquake or other natural disaster; (ii) epidemic or pandemic; (iii) terrorist attack, civil war, cyber-attacks, riots, war, threat of or preparation for war, armed conflict, sanctions or embargos; (iv) Laws or action taken by a government or public authority; (v) systemic electrical, telecommunications or other utility failures; and (vi) any labor or trade dispute, strikes, industrial action or lockouts;

**16.2 Assignment.** We may assign or otherwise transfer the Contract or any of our rights and obligations under the Contract to an Affiliate or successor-in-interest. You shall not, without our prior written consent, assign or otherwise transfer any or all of your rights or obligations under the Contract.

**16.3 Subcontracting.** We are permitted to appoint and use Affiliates and other third parties to perform our obligations or any portion thereof without prior notification to or consent of the Customer.

**16.4 Entire agreement.** The Contract constitutes the entire agreement between the parties in relation to its subject matter. It replaces and supersedes all prior agreements, draft agreements, statements, representations and undertakings of any nature made by or on behalf of the parties, whether oral or written, in relation to that subject matter. The parties agree that the Customer's standard or purchase terms and conditions shall not apply.

**16.5 Variation.** No variation of the Contract shall be effective unless it is in writing and signed by the parties. Notwithstanding the foregoing, we may modify these Terms of Use, STC, the Data Privacy Policy, code of conduct and/or the Acceptable Use Policy from time to time. Any such modification will be subject to notification to you and will be effective as stated in the notification. Should a modification by us become effective during the term of a Contract and have a material adverse effect on your rights or obligations under the Contract, you may terminate the affected Contract within 30 (thirty) days following notification with 30 (thirty) days written notice and we will re-fund you any prepaid amounts for the respective Service on a pro-rata basis for the remainder of the Service term. Such refund is your sole and exclusive remedy. By continuing to use the Services and/or the Software after the effective date of modification, you agree to be bound by the modified terms.

**16.6 No waiver.** A waiver of any right or remedy is only effective if given in writing and shall not be deemed a waiver of any subsequent breach or default. Except as otherwise expressly stated in the Contract, a delay or failure to exercise, or the single or partial exercise of, any right or remedy shall not waive that or any other right or remedy; or prevent or restrict the further exercise of that or any other right or remedy.

**16.7 Severance.** If any provision or part-provision of the Contract is or becomes invalid, illegal or un-enforceable, it shall be deemed modified to the minimum extent necessary to make it valid, legal and enforceable. If such modification is not possible, the relevant provision or part-provision shall be deemed deleted but not affect the validity and enforceability of the rest of the Contract.

**16.8 Code of conduct and anti-bribery law.** We maintain a set of codes of conduct and guidelines related to our, our employees' and our contractors' business conduct, including anti-bribery, anti-corruption and conflict of interest, and we require our suppliers to comply with such codes of conduct or have equivalent codes of conduct, accessible at <https://new.abb.com/about/integ-rity/standards/abb-code-of-conduct>. You shall comply in your business conduct with standards that are equivalent.

**16.9 Notices.** Any notice given to a party under or in connection with the Contract shall be in writing and shall be (i) delivered by hand or courier or by pre-paid registered first-class post or special delivery to the address specified in the Order; or (ii) sent by email to the email address specified in the Order. We may in addition provide notices by email or other electronic notification forms available in the used systems to the address then associated to your account on the Platform.

**16.10 Third party beneficiaries.** No one other than a party to the Contract shall be a beneficiary of the Contract or shall have any right to enforce any of its terms, unless specified in the Contract.

**16.11 Independent contractors.** Each party is an independent contractor, nothing contained in these Terms of Use or the Contract shall form a joint-venture, partnership or agency, and neither party has the authority to bind the other party.

## 17 Definitions and interpretation

### 17.1 Definitions.

**"ABB Content"** means the Services, deliverables provided as part of the Services, ABB Software, the Platforms as well as ABB Device Data (including all tools, software, hardware, materials, data, content, application program interfaces provided by us or our Affiliates as part of or in relation to the Services) as well as all derivatives and modifications of and improvements to all the foregoing, or other ABB intellectual property;

**"ABB Device"** means a physical or virtual device provided or otherwise made available or branded by ABB which generates or gathers data through embedded sensors or otherwise, where such data is accessed, stored or processed by the Services;

**"ABB Device Data"** means any information or data generated or gathered (whether automatically or not) by an ABB Device or ABB Software and which relates to the operation and working of such ABB Device or ABB Software, for example device diagnostics and device health data;

**"ABB Software"** means all computer programs (which may include mobile applications) provided (or given access to) by us under the Contract as part of or in connection with the Services, including any modifications, updates, upgrades, new versions or releases and derivative works as well as any related documentation, but excluding Third Party Software;

**"Acceptable Use Policy"** means the ABB Ability acceptable use policy, available at <https://new.abb.com/abb-ability/terms>, or as provided separately, and as may be updated by us from time to time;

**"Affiliate"** means any entity, whether incorporated or not, which presently or in the future, directly or indirectly controls, is controlled by, or is under common control with a party, by virtue of a controlling interest of 50% or more of the voting rights or the capital, or by means of controlling the constitution of the board and the voting at board meetings;

**"Claim"** has the meaning set out in Section 7.1;

**"Data Privacy Policy"** means the data privacy policy, available at <https://new.abb.com/abb-ability/terms>, as may be updated by us from time to time;

**"Discloser"** has the meaning set out in Section 14.1;

**"External Items"** has the meaning set out in Section 2.4;

**"Intellectual Property Rights"** means (a) inventions, patents, utility models, copyrights, moral rights, mask work rights, database rights and rights in trademarks, trade names, designs, know-how, and invention disclosures (whether registered or unregistered); (b) applications for registration, and the right to apply for registration, for any of these rights; and (c) all other intellectual property rights and equivalent or similar forms of protection existing anywhere in the world;

**"Laws"** means any applicable legislation, regulations, codes of practice, guidance and other requirements of any relevant government, governmental or regulatory agency, authority, or other relevant body, as amended or re-enacted;

**"Order"** means a document in electronic or physical form, an online form or other online instrument provided by us for ordering or procuring Services and/or Software, which refers to these Terms of Use;

**"Personal Data"** means any data or information relating to an identified or identifiable natural person and, where required by mandatory applicable Law, any data or information of an identified or identifiable legal entity;

**"Pilot Services"** means Services that are at a pilot, trial, evaluation or beta stage or that are free of charge;

**"Platform"** means the ABB MyBuildings Portal or the Busch-Jaeger MyBuildings Portal;

**"Recipient"** has the meaning set out in Section 14.1;

**"Services"** means the services to be provided or to be made available by us to you as described or referred to in an Order and the STC;

**"Software"** means ABB Software and Third Party Software;

**"Special Terms and Conditions"** or **"STC"** means the documents describing and/or further governing the Services and/or Software which are referenced in the Order;

**"Third Party Software"** means any computer program (which may include mobile applications), including proprietary, freeware and open source software, that is either licensed (i) to us from a third party, identified in an Order as Third Party Software for use as part of the Services under separate terms and conditions, or (ii) by you from third parties;

**"User"** means an individual who is legitimately authorized to access or receive the Services, use

the Software and/or access the Platform through your account.

**"Your Content"** means any information, data and material that we measure or that is provided by or on behalf of you through or in connection with our provision or your use of the Services or Software, including, for the avoidance of doubt, third party information, data and material that is provided by or on behalf of you; Your Content excludes ABB Device Data.

### 17.2 Interpretation

Any phrase introduced by the terms "e.g.", "including", "include", "in particular", "such as", "for example" or any similar expression, shall be construed as illustrative and shall not introduce an exhaustive list of phrases nor limit the sense of the words preceding those terms.

### 17.3 Order of precedence

To the extent of a conflict, the order of precedence between the documents comprising the Contract, unless differently specified in the Order, is the following (those higher in the list prevailing): (i) the Order; (ii) the STC; (iii) the Data Privacy Policy; (iv) the Acceptable Use Policy; and (v) these Terms of Use.

## 18 Country unique terms

The following country unique terms apply in deviation of the terms in Sections 1 – 17 above, in each case as specified below.

**18.1 Australia.** The following terms apply if you are located in Australia.

Notwithstanding sections 2.3 (Pilot Services), 9.4 (Disclaimer), 10.1 (Limited Liability), 10.2 (Exclusions) and 15 (Governing law and jurisdiction) nor anything else to the contrary stated in the Contract, to the extent a supply by us under the Contract is a supply of goods or services to a consumer within the meaning of Schedule 2 to the Competition and Consumer Act 2010 (legislation of the Commonwealth of Australia) ("**ACL**"):

(i) nothing contained in the Contract affects any provision of or right, remedy or liability under the ACL, provided that, to the extent that the ACL permits us to limit our liability, our total aggregate liability, for failure to comply with a guarantee under the ACL in respect of the supply of goods or services under the Contract is limited to: (1) in the case of services, either of the remedies described at sub-section 64A(2)(a) or (b) of the ACL, at our election; and (2) in the case of goods, one or more of the remedies described at sub-section 64A(1)(a) to (d) of the ACL, at our election;

(ii) our goods and services come with guarantees that cannot be excluded under the ACL. For major failures with the service, you are entitled: to cancel your service contract with us; and to a refund for the unused portion, or to compensation for its reduced value. You are also entitled to choose a refund or replacement for major failures with goods. If a failure with the goods or a service does not amount to a major failure, you are entitled to have the failure rectified in a reasonable time. If this is not done you are entitled to a refund for the goods and to cancel the contract for the service and obtain a refund of any unused portion. You are also entitled to be compensated for any other reasonably foreseeable loss or damage from a failure in the goods or service; and

(iii) except to the extent a warranty might be excluded in the Order or the STC, the Contract contains warranties against defects (see section 9 (Warranties)), and as such is required to state who will bear the expense of claiming under the warranty. You must bear the expense (if any) of actually making a claim under the warranty. The benefits to you given by any of the warranties are in addition to other rights and remedies of a consumer under the ACL.

**18.2 Brazil.** The following terms apply if both parties are located in Brazil.

Section 15.1 shall be replaced by the following: **Governing law.** The Contract, and any dispute or claim (including non-contractual disputes or claims) arising out of or in connection with it or its subject matter or formation shall be governed by, and construed in accordance with the substantive **laws of Brazil**, excluding both its conflict of laws provisions and the United Nations Convention on Contracts for the International Sale of Goods (Vienna, 1980).

Section 15.2 shall be replaced by the following: **Jurisdiction.** Any dispute, controversy or claim arising out of, or in relation to, the Contract, including the validity, invalidity, breach, or termination thereof, shall be resolved by arbitration in accordance with the rules of the **Arbitration Tribunal of the Commercial Chamber Brazil-Canada** ("Tribunal Arbitral da Câmara de Comércio Brasil-Canada") in force on the date on which the notice of arbitration is submitted in



accordance with these rules. The number of arbitrators shall be three. The seat of the arbitration shall be **São Paulo/SP**. The arbitral proceedings shall be conducted in Portuguese.

**18.3 Canada.** The following terms apply if both parties are located in Canada.

A new Section 16.12 will be added as follows: **Language. We and you have required that the Contract and all deeds, documents and notices relating to the Contract be drawn up in the English language. Nous et vous ont exigé que le présent contrat et tous autres contrats, documents ou avis afférents aux présentes soient rédigés en langue anglaise.**

**18.4 China.** The following terms apply if both parties are located in the People's Republic of China.

Section 15.1 shall be replaced by the following: **Governing law.** Any dispute or claim (including non-contractual disputes or claims) arising out of or in connection with it or its subject matter or formation shall be governed by, and construed in accordance with the substantive **laws of the People's Republic of China.**

Section 15.2 shall be replaced by the following: **Jurisdiction.** Any dispute, controversy or claim arising out of, or in relation to, the Contract, including the validity, invalidity, breach, or termination thereof, shall be re-solved by arbitration by the **China International Economic and Trade Arbitration Commission in Beijing ("CIETAC")** in accordance with the CIETAC's arbitration rules in force on the date on which the notice of arbitration is submitted in accordance with these rules. The number of arbitrators shall be three. The seat of the arbitration shall be **Beijing**. The arbitral proceedings shall be conducted in Chinese.

**18.5 France.** The following terms apply if both parties are located in France.

Section 5.1, the last sentence shall be replaced by the following: Late payment interest of 12% per annum will be charged in case of late or incomplete payment, as well as lump compensation of 40 (forty) euros for recovery costs.

Section 11 shall be replaced by the following: **Suspension.** We may suspend the Services in whole or in part if it is apparent that your use of the Services (i) poses a security risk to the Services, the Platform and/or the Platform and/or any third party; (ii) may adversely impact the performance of the Services, the Software and/or Platform; (iii) is in violation of the Laws or poses a risk that we are or will be in violation of the Laws; (iv) may subject us or any third party to liability. In addition, we may suspend the Services under the circumstances specified in the Acceptable Use Policy and if you fail to pay any amount due under the Contract on the due date for payment. We will suspend the Services only to the extent reasonably necessary. Unless it is apparent that an immediate suspension is required and appropriate, we will use commercially reasonable efforts to provide reasonable notice before suspending a Service.

**18.6 Germany.** The following terms apply if you are located in Germany or if the parties (explicitly) agree on the application of German law.

The word "prompt" or "promptly" is replaced by "without undue delay".

Section 2.1: the last sentence shall be replaced by the following provision: "To the extent that the Pilot Services will be provided free of charge, we shall only be under any warranty or liability in case of intent, gross negligence or if we fraudulently conceal a defect (fraudulent concealment)."

Section 2.2: the last sentence shall be replaced by the following provision: "We make no warranties or representations and we have no obligation, responsibility or liability for External Items and your use of External Items; you waive any right or claim of right against us relating to External Items; however, this shall not apply in view of defects in External Items, if (a) we requested the use of such External Items, (b) such External Items is defective, (c) such defect impacts the use of the Services as foreseen in the Contract), and (d) we were aware (at the time of requesting) of such impacts as per (c) above or if we have intentionally or grossly negligently ignored such impacts."

Section 5.1 is modified: You shall not be hindered to set off your claims or withhold the performance, if your claims, on which the set-off or withholding is based, are undisputed or have been adjudicated by non-appealable judgement.

Section 9.2 shall be amended by the following provision: "For ABB Software provided to you without time limit the warranty shall apply for a period of twelve (12) months following delivery of the ABB Software to you. In view of ABB Software provided to you for a limited period of time any guarantee in view of the absence of initial defects shall be excluded. However, in cases of intent, gross negligence, loss of life, bodily injury or damage to health, or if ABB fraudulently conceals a defect, instead of the preceding sentences the warranty provided by law shall apply."

Section 9.3 shall be amended as follows: “For our warranty obligations in view of the provision of Pilot Services Section 2.3 shall prevail.”

Section 9.4 shall not apply.

Section 10.3 shall be replaced by the following provision:

“**Scope of limitations and exclusions.** The limitation and exclusions to our liability in Sections 10.1 and 10.2 do not apply if liability is based on: (a) the German Product Liability Act (“Produkthaftungsgesetz”); (b) intent; (c) gross negligence; (d) fraud; (e) failure to comply with a guarantee granted; (f) negligent injury to life, limb or health; or (g) negligent breach of a fundamental condition of contract (“wesentliche Vertragspflichten”). However, claims for damages arising from a breach of a fundamental condition of contract shall be limited to the foreseeable damage which is intrinsic to the contract, provided that no other of the above case applies.

The limitations and exclusions of liability also apply to the benefit of our Affiliates, suppliers, licensors, subcontractors as well as our and their directors, officers, employees and representatives. You may not assert any liability claim for breach or non-performance under a Contract against us unless you have given us written notice of the claim within 1 (one) year after you first knew or reasonably should have known of the facts giving rise to such claim.

For our liability in view of the provision of Pilot Services Section 2.3 shall prevail.”

Section 15 shall be replaced by the following provision:

“Governing Law and Jurisdiction

15.1 Governing law. The Contract shall be governed by, and construed in accordance with the substantive laws of Germany excluding both its conflict of laws provisions and the United Nations Convention on Contracts for the International Sale of Goods (Vienna, 1980).

15.2 Jurisdiction. Any dispute, controversy or claim arising out of, or in relation to, the Contract, including the formation, validity, invalidity, breach, or termination thereof, shall be finally settled in accordance with the Arbitration Rules of the German Institution of Arbitration (DIS) without recourse to the ordinary courts of law. The number of arbitrators shall be three. The seat of the arbitration shall be Mannheim. The arbitral proceedings shall be conducted in English.”

**18.7 India.** The following terms apply if you are located in India.

Section 15.1 shall be replaced by the following: **Governing law.** The Contract, and any dispute or claim (including non-contractual disputes or claims) arising out of or in connection with it or its subject matter or formation shall be governed by, and construed in accordance with the substantive **laws of India.**

Section 15.2 shall be replaced by the following: **Jurisdiction.** Any dispute, controversy or claim arising out of, or in relation to, the Contract, including the validity, invalidity, breach, or termination thereof, shall be resolved by arbitration in accordance with the **Arbitration and Conciliation Act, 1996** and its amendments in force on the date on which the notice of arbitration is submitted in accordance with this law. The number of arbitrators shall be three. The seat and venue of the arbitration shall be **Bengaluru, India.** The arbitral proceedings shall be conducted in English.

**18.8 Russia.** The following terms apply if both parties are located in Russia.

The charges set out under Section 5.1 inter alia includes remuneration for any applicable Intellectual Property Rights assignment and/or licensing under the applicable Order.

**18.9 Saudi Arabia.** The following terms apply if both parties are located in Saudi Arabia.

Section 15.1 shall be replaced by the following: Governing law. The Contract shall be governed by and construed and interpreted in accordance with the laws of the Kingdom of Saudi Arabia.

Section 15.2 shall be replaced by the following: Jurisdiction. Any dispute or difference arising out of or in connection with the Contract, including any question regarding its existence, validity or termination or the legal relationships established thereby, which cannot be settled amicably, shall be submitted to the jurisdiction of the Board of Grievances (Commercial Divisions) sitting in Riyadh and established pursuant to Royal Decree No. M/51 dated 17/7/1402 H. (10 May 1982).

**18.10 Taiwan.** The following terms apply if both parties are located in Taiwan.

Section 15.1 shall be replaced by the following: **Governing law.** The Contract, and any dispute or claim (including non-contractual disputes or claims) arising out of or in connection with it or its subject matter or formation shall be governed by, and construed in accordance with the substantive **laws of Taiwan** excluding both its conflict of laws provisions and the United Nations Convention on Contracts for the International Sale of Goods (Vienna, 1980).

Section 15.2 shall be replaced by the following: **Jurisdiction.** Any dispute, controversy or claim arising out of, or in relation to, the Contract, including the validity, invalidity, breach, or termination thereof, shall be resolved by arbitration in accordance with the **Rules of Chinese Arbitration Association** in force on the date on which the notice of arbitration is submitted in accordance with these rules. The number of arbitrators shall be three. The seat of the arbitration shall be **Taipei, Taiwan**. The arbitral proceedings shall be conducted in English.

**18.11 United States of America.** The following terms apply if you are located in the United States of America.

A new Section 2.8 will be added as follows: **Government Agency.** The Software is commercial computer software, as such term is defined in 48 C.F.R. §2.101. Accordingly, if you are an agency of the United States Government or any contractor therefor, you receive only those rights with respect to Software as are granted to all other end users under license, in accordance with (a) 48 C.F.R. §227.7201 through 48 C.F.R. §227.7204, with respect to the United States Department of Defense and their contractors, or (b) 48 C.F.R. §12.212, with respect to all other United States Government licensees and their contractors.

Section 15.1 shall be replaced by the following: **Governing law.** All aspects of the Contract and any disputes arising under it shall be governed by and construed and interpreted in accordance with **Delaware law**.

Section 15.2 shall be replaced by the following: **Jurisdiction.** The parties consent to the exclusive jurisdiction of the **federal courts in the state of Delaware** as the sole and exclusive forum for the resolution of all disputes arising under or related to the Contract. Should the federal courts not have subject matter jurisdiction over any such dispute, the parties consent to the exclusive jurisdiction of the state courts in the state of Delaware as the sole and exclusive forum for the resolution of all disputes arising under or related to the Contract.

**18.12 Vietnam.** The following terms apply if you are located in Vietnam.

Section 15.1 shall be replaced by the following: **Governing law.** The Contract, and any dispute or claim (including non-contractual disputes or claims) arising out of or in connection with it or its subject matter or formation shall be governed by, and construed in accordance with the substantive **laws of Vietnam** excluding both its conflict of laws provisions and the United Nations Convention on Contracts for the International Sale of Goods (Vienna, 1980).

Section 15.2 shall be replaced by the following: **Jurisdiction.** Any dispute, controversy or claim arising out of, or in relation to, the Contract, including the validity, invalidity, breach, or termination thereof, shall be resolved by the **Vietnam International Arbitration Centre at the Vietnam Chamber of Commerce and Industry (VIAC)** in accordance with its Rules of Arbitration in force on the date on which the notice of arbitration is submitted in accordance with these rules. The number of arbitrators shall be three. The seat of the arbitration shall be **Vietnam**. The arbitral proceedings shall be conducted in English.

## 13 Maintenance

The device is maintenance-free. In case of damage, e.g. during transport or storage), do not perform repairs. Once the device is opened, the warranty is void.

Access to the device must be guaranteed for operation, testing, inspection, maintenance and repairs (according to DIN VDE 0100-520).

## 14 Notes

## 15 Index

- "
- "Scheduler" application ..... 254
- A**
- Activate long press ..... 123, 190, 205
- Actuation at a long press of the button after... 123, 206
- Add <Physical meter> ..... 240
- Add control ..... 252
- Additional necessary components ..... 22
- Address external page ..... 251
- Address of external page x ..... 244
- Air pressure value ..... 202
- Alias text of link x ..... 246
- Animation timeout ..... 159, 173
- App applications ..... 342
- Application
- "Alarms" ..... 99, 261
  - "Local scene" ..... 105, 267
  - "Sequence" ..... 270
- Applications and application pages
- Configuration ..... 25, 86, 254
- Architectural and template mode ..... 83
- Assignment
- All functions of a building architectural element ..... 289
  - General ..... 83, 284
  - Individual control ..... 286
  - Project assignment ..... 292
- At failure of lamp / disable ballast ..... 206
- Automated display mode ..... 195
- Automatic command ..... 138, 145, 230
- Automatic mode visible ..... 131, 140, 224
- B**
- Behaviour of redirection ..... 245, 251
- Behaviour of the control ..... 159, 179
- Blue command ..... 235
- Blue status ..... 235
- Boost command ..... 138, 145, 230
- Boost stage ..... 132
- Boost status ..... 230
- Boost switch visible ..... 132, 141, 225
- Boost value ..... 141, 225
- Brightness command ..... 116, 121, 130, 213
- Brightness sensor disrupted ..... 203
- Brightness status ..... 116, 121, 130
- Brightness value ..... 202
- Burn-in lamp command ..... 214
- Burn-in lamp status ..... 214
- Burn-in trigger activation ..... 207
- Button position ..... 129, 212
- C**
- Category ..... 240, 242
- Colour channels ..... 233
- Colour for error state ..... 220
- Colour for OK state ..... 219
- Colour for running test trial state ..... 220
- Colour for unknown state ..... 220
- Colour of function line ..... 103
- Colour space ..... 232
- Command
- Relative dimming ..... 130
- Command value ..... 194, 236
- Command: Overwrite operation mode ..... 229
- Condensate alert ..... 230
- Connection, installation / mounting ..... 30
- Control
- "Dimmer preset values" ..... 112
  - "RGBW" ..... 232
  - "Switch" ..... 179
  - "Value for slider" ..... 188
  - Copy ..... 252
  - Delete ..... 253
  - Control "DALI emergency light" ..... 215
  - Control "Energy display" ..... 238
  - Control "Local scene" ..... 105, 267
  - Control "Page links" ..... 244
  - Control "Scheduler viewer" ..... 156
  - Control "Sequence" ..... 108, 270
  - Control "Stepwise dimmer" ..... 122
  - Control "Trend viewer" ..... 64, 186
  - Control actions of additional applications ..... 25, 319
  - Control element
    - "Dimmer slider" ..... 117  - Control functions ..... 221
  - Controls ..... 99, 301
    - Additional basic principles ..... 303
    - Basic structures ..... 301
    - Variable ..... 24, 305  - Converter ..... 285
  - Creating a project ..... 41, 44, 49
  - Crop image ..... 248, 251
  - Current temperature ..... 229
  - Current temperature fault ..... 229
- D**
- Data and activity logs ..... 350
- Data point for status notifications ..... 160
- Data point for the setpoint settings ..... 221
- Data points .... 107, 111, 116, 121, 130, 138, 145, 152, 155, 158, 172, 177, 185, 194, 202, 213, 220, 229, 235, 241, 243, 249
- Editing ..... 278
- Date ..... 203
- Day/Night ..... 202
- Day/night sensor disrupted ..... 204
- Decimal places for information value .... 106, 109, 113, 119, 124, 134, 144, 148, 153, 156, 161, 174, 180, 186, 192, 196, 209, 228, 246
- Default representation ..... 149
- Delay between messages ..... 105
- Delete project ..... 48

- Description of functions ..... 27
- Development ..... 351
- Device overview ..... 23
- Dimensional drawings ..... 29
- Disable.... 107, 111, 116, 121, 130, 138, 145, 155, 172, 178, 185, 194, 213, 220, 229, 237, 249
- Display air pressure ..... 199
- Display alias text ..... 246
- Display brightness ..... 198
- Display building position..... 200
- Display date/time ..... 199
- Display day/night ..... 198
- Display felt temperature ..... 197
- Display humidity ..... 197
- Display minimum/maximum value ..... 120
- Display numerical value ..... 151
- Display precipitation ..... 198
- Display setting ..... 187
- Display status value ..... 190
- Display sunrise / sunset..... 199
- Display text for "Position out of range" ..... 192
- Display wind speed ..... 197
- E**
- Edit mode ..... 312
  - Call-up and editing of the favourites page ..... 315
  - Edit navigation tree ..... 313, 315
- Editing mode
  - Creating and editing links ..... 317
- Editing the navigation structure ..... 96
- Electrical connection ..... 33
- Enable information text ..... 104
- End User Licence Agreement ..... 356
- Energy display ..... 339
- Environment ..... 20
- Error during time synchronization ..... 203
- Exceptions ..... 334
- Exchange orientation ..... 191
- External x - Colour ..... 238
- F**
- Fan speed command ..... 138, 145, 229
- Felt temperature value ..... 202
- Filter functions..... 84
- Firmware update ..... 354
- Forced operation command x Bit ..... 213
- Forced operation mode activation..... 208
- Forced operation object type ..... 208
- Forced operation status x Bit ..... 214
- Functions..... 24, 100
- G**
- General control and display functions..... 296
- General parameters ..98, 100, 105, 108, 112, 117, 122, 131, 139, 146, 153, 156, 159, 173, 179, 186, 188, 195, 205, 215, 221, 232, 238, 244, 250
- General sensor failure ..... 203
- GPS latitude ..... 203
- GPS longitude ..... 203
- Green command ..... 235
- Green status ..... 235
- Group addresses
  - Editing ..... 279
- Group Addresses..... 282
- H**
- Headline symbol..... 102
- Headline text ..... 101
- Headline visible ..... 101
- Heating/Cooling command ..... 231
- Heating/Cooling support ..... 222
- Hue command ..... 235
- Hue status ..... 236
- HVAC status ..... 229
- I**
- Image..... 250
- Image of link x..... 247
- Improper use ..... 18
- Information on protection of the environment..... 20
- Information value ... 107, 111, 116, 121, 130, 138, 145, 152, 155, 158, 172, 178, 185, 194, 202, 213, 229, 237, 249
- Initial commissioning ..... 34
- Integration into the KNX system ..... 37
- Intended use ..... 18
- IoT Dashboard Server settings..... 349
- L**
- Lamp aging ..... 220
- Lamp/ballast failure..... 213
- Last executed scene ..... 107
- LED cold white command ..... 237
- LED cold white status..... 237
- LED colour concept ..... 27
- LED HSV command ..... 236
- LED HSV status..... 236
- LED RGB command ..... 236
- LED RGB status ..... 236
- LED warm white command ..... 237
- LED warm white status ..... 237
- LED white command ..... 237
- LED white status..... 237
- Legal information ..... 356
- License text ..... 356
- Lock control..... 104
- M**
- Main divisions ..... 150
- Maintenance ..... 374
- Master switch command ..... 235
- Master switch status ..... 235
- Maximum value ..... 117, 142, 147, 191, 226
- Minimum value ..... 117, 142, 147, 191, 226
- Mounting..... 32
- Move slats ..... 177
- Move to pos. height ..... 177
- Move up/down ..... 172
- N**
- Navigation structure



Creation .....	76, 82, 85, 86
Normal operation mode command .....	229
Notes .....	375
Notes on the instruction manual .....	16
Notification center .....	322
Number of colour ranges .....	149
Number of decimals .....	148, 190
Number of external data .....	238
Number of label decimals .....	151
Number of loops .....	108
Number of presets .....	112
Number of stages .....	131, 132
Number of web links .....	244

**O**

ON/OFF behaviour .....	133, 143, 227
ON/OFF Command .....	138, 145, 229
ON/OFF Status .....	138, 145, 229
Operating pages	
Configuration .....	86, 98
Creating floors .....	90
Creating rooms .....	93
Editing .....	96
Operation via ABB i-bus® KNX IoT Dashboard .....	296
Overrun Delay .....	131, 141, 225

**P**

Parameters 99, 100, 105, 108, 112, 117, 122, 131, 139, 146, 153, 156, 159, 173, 179, 186, 188, 195, 205, 215, 221, 232, 238, 240, 242, 244, 250, 258	
Pause .....	111
Paused .....	111
Permit switching between heating and cooling .....	222
Permitting the activation of the overwriting mode .....	222
Play .....	111
Precipitation .....	202
Predefined colour x .....	233
Preparatory steps .....	31
Prerequisites .....	36
Presence detectors .....	229
Project backup .....	47
Project templates .....	85

**Q**

Qualification of personnel .....	19
----------------------------------	----

**R**

Red command .....	235
Red status .....	235
Relative humidity .....	202
Repeat on error .....	105
Representation in control 106, 109, 113, 119, 125, 134, 154, 161, 181, 209, 244	
RESET .....	295
Resetting the device .....	295
Restart .....	111
RGB On/Off command .....	235
RGB On/Off status .....	235
Rights of user groups .....	79
Rights of users .....	80
Running .....	111

**S**

Safety .....	17
Safety instructions .....	19, 30
Saturation command .....	236
Saturation status .....	236
Scene command .....	107, 155
Schedulers .....	325
Scope of supply .....	22
Send datapoint .....	179
Show burn-in state .....	207
Show dependencies .....	259
Show forced operation state .....	207
Show labels .....	150
Show last event .....	157
Show measured temperature .....	196
Show next event .....	157
Show status value .....	142, 226
Software information .....	72
Special functions .....	312
Standard information text .....	106, 108, 112, 118, 124, 133, 143, 148, 153, 156, 160, 174, 180, 186, 192, 196, 209, 227, 245
Start Delay .....	131, 141, 224
Start of colour range x .....	149
Start/Stop command .....	130
Status Automatic .....	138, 145, 230
Status Fan speed .....	138, 145, 230
Status height .....	172, 177
Status lower end position .....	172, 178
Status slat .....	177
Status upper end position .....	172, 177
Status value .....	152, 194, 236
Step size .....	117, 122, 142, 191, 206, 226
Step width (fine adjustment) .....	191
Stop .....	111
Stop / slat adjustment .....	172
Style of control .....	215
Style sheet .....	101
Subdivisions .....	150
Support master On/Off .....	233
Support RGB On/Off .....	234
Support white On/Off .....	234
Supporting dimming functions .....	205
Switch command .....	121, 130, 185, 213
Switching status .....	121, 130, 185, 213
Switching time .....	195
Symbol .....	110, 114, 120, 128, 135
Symbol for "Move down" .....	166
Symbol for "Move left" .....	169
Symbol for "Move right" .....	170
Symbol for "Move up" .....	165
Symbol for "OFF" .....	183
Symbol for "ON" .....	182
Symbol for "Step down" .....	164
Symbol for "Step left" .....	167
Symbol for "Step right" .....	168
Symbol for "Step up" .....	163
Symbol for "Stop" .....	171
Symbol for "Undefined" .....	184

- Symbol for adjusting the slats ..... 176  
 Symbol for decrease..... 127, 211  
 Symbol for error state ..... 218  
 Symbol for increase ..... 125, 210  
 Symbol for move direction ..... 162, 175  
 Symbol for OK state ..... 216  
 Symbol for running test trial state..... 217  
 Symbol for unknown state..... 219  
 Symbol preset mode..... 113, 134  
 Symbols library..... 70  
 System settings ..... 348
- T**
- Target group..... 19  
 Technical data ..... 28  
 Temperature setpoint command ..... 230  
 Temperature setpoint status ..... 230  
 Temperature step command ..... 230  
 Temperature step status ..... 230  
 Temperature step width..... 223  
 Temperature unit..... 201  
 Temperature value ..... 202  
 Text for "Position out of range" ..... 193  
 Text for adjust slats..... 177  
 Text for change of height ..... 175  
 Text for preset x..... 115, 136  
 Text for stage x ..... 137  
 Tile overview timescale ..... 238  
 Time interval ..... 191  
 Time of day ..... 203  
 Time of sunrise..... 203  
 Time of sunset ..... 203  
 Timeout for boost ..... 132, 141, 225
- Title information .... 105, 108, 112, 117, 123, 133, 143,  
 148, 153, 156, 160, 173, 180, 186, 192, 195, 208,  
 227, 245  
 Today..... 330  
 Tool tip for the buttons ..... 104  
 Trend viewer..... 336  
 Twilight sensor disrupted ..... 203  
 Type of blind..... 159, 173  
 Type of dimmer ..... 122
- U**
- Unit ..... 139, 146, 188, 223  
 Unit of wind speed ..... 200  
 Update ..... 354  
 Update und backup ..... 352  
 Use predefined colours ..... 233  
 User account settings..... 348  
 User rights..... 76, 79, 81, 97, 317
- V**
- Value ..... 241, 243  
 Value of preset x ..... 112
- W**
- Weekly ..... 331  
 White On/Off command..... 236  
 White On/Off status ..... 237  
 Wind sensor disrupted ..... 204  
 Wind speed ..... 202  
 Window contact ..... 229
- X**
- X-Axis ..... 187
- Y**
- Y-Axis ..... 187



---

**Busch-Jaeger Elektro GmbH**  
**A member of the ABB Group**

PO box  
58505 Lüdenscheid

Freisenbergstraße 2  
58513 Lüdenscheid

[www.BUSCH-JAEGER.com](http://www.BUSCH-JAEGER.com)  
[info.bje@de.abb.com](mailto:info.bje@de.abb.com)

Central sales service:  
Tel.: +49 2351 956-1600  
Fax: +49 2351 956-1700