

- **Fully submersible, rugged and robust sensor**
 - reliable, maintenance-free operation in arduous environments
- **'Hot tap' capability**
 - enables installation with no interruption to normal water supply
- **Good accuracy over wide operating flow range in both forward and reverse flow directions**
 - enables user to accurately measure peak daytime flows and minimal night flows
- **Price virtually independent of pipe diameter**
 - low cost alternative to full bore meters
- **Suitable for permanent or temporary installation**
 - total user flexibility
- **No moving components and hence no bearing wear problems**
 - stable calibration and reliable operation
- **Choice of transmitter**
 - fully satisfies user application requirements



AquaProbe

The AquaProbe is an economic alternative to full-bore metering and has been designed for worldwide needs. It comprises an electromagnetic sensing head mounted on the end of a support rod. This whole assembly can be installed in existing pipelines without the need for the major excavations or alterations to pipework associated with full bore meters. It can also be fitted without interruption to the flow and can be easily removed for periodic calibration or inspection, or inserted at a second location through the provision of tappings and valves on the supply pipelines.

Key features are the wide flow range, with minimum velocities well below insertion turbine or DP devices and no moving parts, resulting in increased reliability and reduced maintenance. The AquaProbe meets the widest variety of site requirements and applications, from permanent monitoring through to site surveying.

AquaProbe offers both digital and analog outputs proportional to flow and is compatible with the wide range of data loggers used in the water industry worldwide.

Basic Applications

The AquaProbe is designed for installation in existing pipelines by means of a small valved tapping. It is normally installed with the sensing head on the pipe centre line, but may be located at the critical position (the mean velocity position) a distance of $\frac{1}{8}$ of the diameter away from the wall.

It provides an accurate local measurement of the water velocity and, provided the flow profile is fully developed, a good flow volume measurement.

If the profile is not fully developed a traverse of the pipe can be carried out which will enable an accurate flow volume measurement to be obtained in non-ideal networks.

The AquaProbe is supplied as standard with the MagMaster transmitter which, being a high precision device, gives excellent performance, whether in temporary or permanent installations, in profiling or pipelines. It offers a wide range of options on terms of output, diagnostics, communications and user facilities.

Specification

Sensor

Signal Cable

Supplied and potted in lengths of 3, 10 and 30m (10, 30, and 100 ft) with connectors if appropriate.

Maximum Insertion Length

300mm (12 in.), 500mm (20 in.), 700mm (25 in.) and 1000mm (40 in.)

Pipe Sizes

200mm to 8000mm (8 in. to 320 in.) nominal bore

Materials of Construction

Wetted parts: stainless steel, PVC (UKWFBS listed)

Seals

Nitrile rubber (WRC approved)

Terminal Box

Aluminum alloy

Max. Pressure

20bar (295 PSI)

Pressure Tapping Provision

$\frac{1}{8}$ in. BSP ($\frac{1}{8}$ in. NPT)

Weight

< 3.5kg (6 lb)

Temperature

Storage

-20 to 70°C (-4 to 158°F)

Operation

-20 to 60°C (-4 to 140°F)

Fluid (water)

0 to 60°C (32 to 140°F)

Protection

IP68/NEMA6 [for submersion to 10m (30 ft) indefinitely]

Conductivity

>50 μ S/cm

Connection

1 in. BSP, 1 $\frac{1}{2}$ in. BSP (1 in. NPT)

Mounting

Directly into the pipeline through a fitting or valve with 25mm (1 in.) minimum clearance

Flow Condition

Fully developed profile in accordance with ISO 7145-1982 (BS1042 section 2.2.)

Temperature Effects

< 0.02% per °C (< 0.01% per °F)

Velocity

±2% of Rate or ±2mm/s (±0.08in/s) whichever is the greater

Volume

Refer to ISO 7145-1982 (BS 1042 section 2.2) for details

Maximum Flow

The maximum velocity depends upon the insertion length of the probe into a pipe; typical insertion lengths are 1/8 and 1/2 pipe diameter. The graph below is a guide* to the maximum velocities for different insertion lengths†.

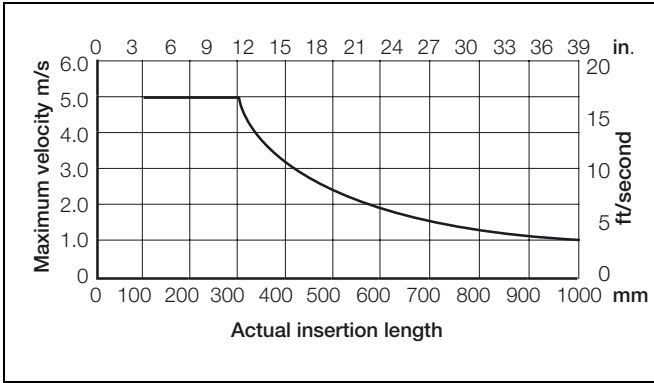

*The graph is intended as a guide only. It is not possible to be definite as there are many effects which cannot be allowed for in such circumstances. For example, pipe vibration, fluid vibration due to pump noise, position of cable, orientation of probe entry, etc.

†The overall probe length must allow for any probe mounting features, such as standoffs, bushes etc., in addition to the length of insertion into the pipe.

MagMaster Transmitter

Housing

Glass Loaded Polypropylene with polycarbonate window

Protection

IP65/NEMA 4

Supply

Universal Switch mode 85 to 265V AC 50/60Hz at 20VA max. or 11 to 40V DC at 20VA

Programming

To operate with most RS232C/423 terminals (e.g. Psion Organizer, IBM PC etc.) 4800 Baud at 10m (30 ft) maximum

Display (optional)

32-character high-temperature super twist LCD alphanumeric display of flow rate, total flow, alarm conditions, etc. display scrolled and reset by magnetic wand

Outputs

Analog

Fully programmable for zero and FSD up to 21mA. Fully isolated. Load <800Ω

Dual Analog (optional)

As above but separate outputs for forward and reverse flows. Non-active output is 4 or 0mA

Dual Pulse

Forward and reverse flows 0 to 800Hz square wave or fixed pulse width up to 2.5s. Fully programmable isolated protected transistor switch capable of sinking >250mA. Voltage <35V

Dual Alarms

Isolated protected transistor switch capable of sinking >250mA. Voltage <35V. Fully programmable. Not isolated from dual-pulse output

Communications

RS232C local data connector for hand held configurator set up via 9-pin D connector

Serial communications RS432/422 compatible data link

Weight

0.5kg (1 lb)

Temperature

Operating

-20 to 60°C (-4 to 140°F)

Storage

-20 to 75°C -4° to 170°F)

Temperature Effect

±0.008%/°C (±0.004%/°F)

EMC Spec

EN 50081-1 (BS6667) to 10V/m (3V/ft)

Overall Dimensions

AquaProbe™ Sensor

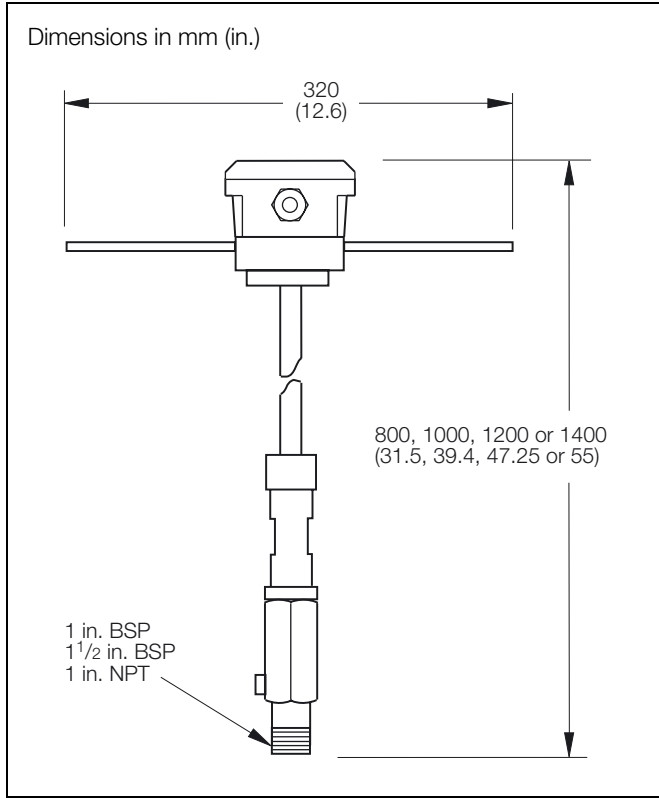

MagMaster™ Transmitter



ABB has Sales & Customer Support expertise
in over 100 countries worldwide

www.abb.com

The Company's policy is one of continuous product
improvement and the right is reserved to modify the
information contained herein without notice.

Printed in UK (04.07)

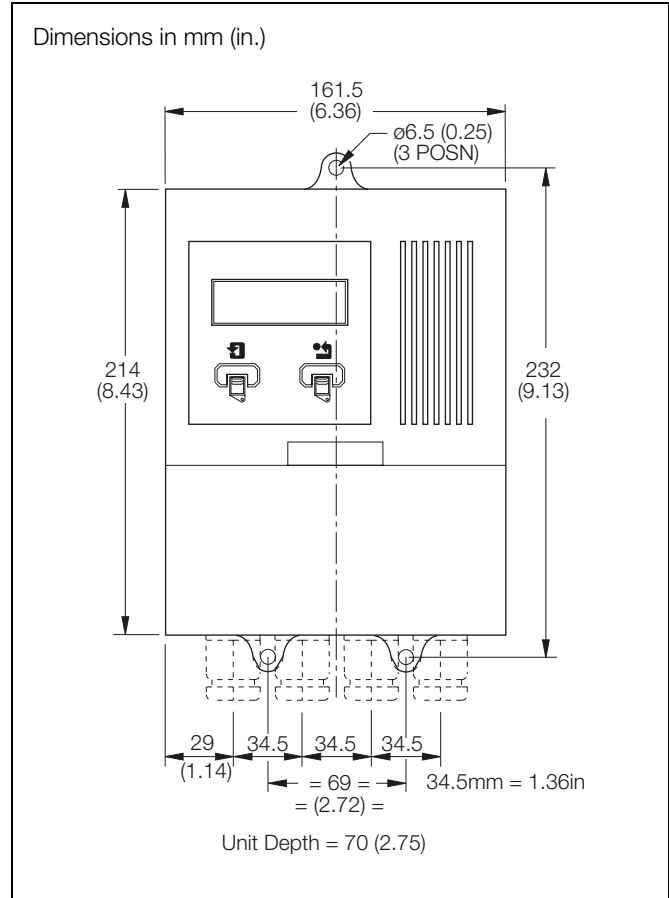
© ABB 2007

ABB

ABB Limited
Oldends Lane, Stonehouse
Gloucestershire
GL10 3TA
UK
Tel: +44 (0)1453 826661
Fax: +44 (0)1453 829671

ABB Inc.
125 E. County Line Road
Warminster
PA 18974
USA
Tel: +1 215 674 6000
Fax: +1 215 674 7183



Standard Product=

Code

AquaProbe Insertion Flowmeter MF/A**1 : Length**

300 mm (12 in.)	301
500 mm (20 in.)	501
700 mm (27 in.)	701
1000 mm (39 in.)	102

2 : Sliding Joint

1.0 in. NPT, with 1/8 in. NPT Pressure Tapping	3
--	---

3 : Reserved

Reserved	10101
----------	-------

4 : Cabling

No Cable Supplied	00
10 m (33 ft.) Fitted to Sensor and Potted	10
20 m (66 ft.) Fitted to Sensor and Potted	20
30 m (98 ft.) Fitted to Sensor and Potted	30

5 : Glanding

North American Option, 0.5 in. NPT Drilling on Terminal Box	4
---	---

6 : Transmitter Mounting

Remote	ER
--------	----

7 : Power Supply

None (Sensor only)	0
85 ... 265 V AC	1
11 ... 40 V DC	3

8 : Display

None (No Transmitter)	0
2 Line Display, High Security Version	(Note: 1) 3
3 Line Display with Keypad, No RS422 or HART	(Note: 1) 4

9 : Output Options

Standard Output / No Transmitter	0
Dual Current Output	(Note: 1) 1
HART communications	(Note: 2) 2

10 : Transmitter Build Standard

No Transmitter	0
Standard	1

11 : Display Orientation

No Display	0
Standard	1

12 : Language

English	11
---------	----

Note 1: Not available with Power Supply code 0

Note 2: Not available with Display code 4

Note 3: Not available with Power Supply code 0, 3

Note 4: Not with 3-line display or DC supply