



Relion 615<sup>®</sup> series

# Feeder protection and control REF615 ANSI Product guide

---

# Contents

---

1 Description . . . . .	3	17 Inputs and outputs . . . . .	16
2 Standard configurations . . . . .	4 - 5	18 Communication . . . . .	17 - 18
3 Protection functions . . . . .	6 - 8	19 Technical data . . . . .	19 - 42
4 Application . . . . .	9 - 11	20 Display options . . . . .	43
5 Supported ABB solutions . . . . .	12 - 13	21 Mounting methods . . . . .	44
6 Control . . . . .	14	22 Relay case and relay plug-in unit . . . . .	44
7 Measurement . . . . .	14	23 Selection and ordering data . . . . .	45
8 Digital fault recorder . . . . .	14	24 Accessories and ordering data . . . . .	46
9 Events recorder . . . . .	14	25 Tools . . . . .	47
10 Fault recorder . . . . .	14	26 Terminal diagrams . . . . .	48 - 49
11 Circuit-breaker monitoring . . . . .	15	27 Certificates . . . . .	50
12 Trip-circuit supervision . . . . .	15	28 References . . . . .	50
13 Self-diagnostics . . . . .	15	29 Functions, codes and symbols . . . . .	51 - 52
14 Fuse failure protection . . . . .	15	30 Document revision history . . . . .	53
15 Current circuit supervision . . . . .	15	31 Notes . . . . .	54 - 55
16 Access control . . . . .	16		

## Disclaimer

The information in this document is subject to change without notice and should not be construed as a commitment by ABB Inc. ABB Inc. assumes no responsibility for any errors that may appear in this document.

Copyright © 2008-2009 ABB

All rights reserved.

## Trademarks

ABB is a registered trademark of ABB Group. All other brand or product names mentioned in this document may be trademarks or registered trademarks of their respective holders.

# 1. Description

The REF615 is a dedicated feeder IED perfectly aligned for the protection, control, measurement and supervision of utility substations and industrial power systems. REF615 is a member of ABB's Relion® family and a part of its 615 protection and control product series. The 615 series IEDs are characterized by their compactness and withdrawable design. Engineered from the ground up, the 615 series has been designed to unleash the full potential of the IEC 61850 standard for communication and interoperability of substation automation devices.

## Unique REF615 ANSI features

- Four setting groups
- Drawout design
- High impedance (HIZ) fault detection
- Arc flash detection (AFD)
- Thermal overload protection of feeder cable
- Ring-lug terminals for all inputs and outputs
- Large, easy to read LCD screen
- Environmentally friendly design with RoHS compliance

The REF615 provides main protection for overhead lines, cable feeders, and busbar systems of distribution substations. It can be applied for protection and control of grounded and ungrounded distribution systems. Flexible order coding allows for choosing current-only or current-and-voltage configurations to best fit your distribution feeder application needs.

The REF615 is the most powerful, advanced and simplest feeder protection relay in its class, perfectly offering time and instantaneous overcurrent, negative sequence overcurrent, phase discontinuity, breaker failure, thermal overload, and voltage metering and protection. The relay also features optional high impedance fault (HIZ) and sensitive earth fault (SEF) protection for grounded and ungrounded distribution systems. Also, the relay incorporates a flexible three-phase multi-shot auto-reclose function for automatic feeder restoration in temporary faults on overhead lines.

Enhanced with safety options, the relay offers a three-channel arc-fault detection system for supervision of the switchgear.

The REF615 also integrates basic control functionality, which facilitates the control of one circuit breaker via the relay's front panel human machine interface (HMI) or remote control system. To protect the relay from unauthorized access and to maintain the integrity of information, the relay has been provided with a four-level, role-based user authentication system, with individual passwords for the viewer, operator, engineer, and administrator levels. The access control system applies to the front panel HMI, embedded web browser based HMI, and the PCM600 relay setting and configuration tool.

REF615 supports the new IEC 61850 standard for inter-device communication in substations. The relay also supports the industry standard DNP3.0 and Modbus® protocols.

## 2. Standard configurations

The REF615 relay main application is feeder protection and control and offers two standard configurations whose relay functions and features are based on the analog inputs ordered for that configuration. See Tables 1 and 2 for details.

One configuration comprises a cost effective current-only inputs useful in basic utility and industrial feeder protection and backup phase and ground

overcurrent protection applications. The second configuration includes current and voltage inputs for comprehensive feeder protection and control applications in utility and industrial distribution substations. Both configurations include standard metering, monitoring and control features and sequence of event, fault and digital waveform recording. Advanced Ethernet communications included standard with parallel support of DNP3.0 Level 2+\*, Modbus and IEC61850 and SNTP over TCP/IP. Additional RS-232 and RS-485 serial communication ports are available as options that support user programmable DNP3.0 Level 2+\* or Modbus protocols. Included with the optional serial communication ports is IRIG-B time synchronization.

\* The DNP3.0 Level 2+ implementation includes some Level 3 functionality.

**Table 1. Standard configurations**

Description	Std. config. - functional application
Current-based metering and protection	A
Current-based and voltage-based metering and protection	D

**Table 2. Function and features comparison**

Functions and features	Analog Inputs	3 CT	3 CT+ Ground CT	3 CT+ SEF/HIZ CT	3 CT+Ground CT+5 VT	3 CT+SEF/HIZ CT+5 VT
Included = ●, Optional = ○	Order Code	AA	AB	AC	DA	DB
<b>Protection</b>	<b>ANSI</b>					
Phase overcurrent, 4 elements	51P, 50P-1 <sup>1</sup> , 50P-2 <sup>1</sup> , 50P-3	●	●	●	●	●
Phase long time overcurrent	51LT	●	●	●		
Directional phase overcurrent, 3 elements	67P-1, 67P-2 <sup>1</sup> , 67P-3 <sup>1</sup>				●	●
Neutral overcurrent, 4 elements	51N, 50N-1 <sup>2</sup> , 50N-2 <sup>2</sup> , 50N-3	●	●	●		●
Ground overcurrent, 4 elements	51G, 50G-1 <sup>2</sup> , 50G-2 <sup>2</sup> , 50G-3		●		●	
Directional neutral overcurrent, 3 elements	67N-1, 67N-2 <sup>1</sup> , 67N-3 <sup>1</sup>				●	●
Sensitive earth fault (SEF)	50SEF			●		●
Negative sequence overcurrent, 2 elements	46-1, 46-2	●	●	●	●	●
High impedance fault (HIZ)	HIZ			●		●
Thermal overload	49F	●	●	●	●	●
Phase discontinuity	46PD	●	●	●	●	●
Cold load inrush detection, 2 elements	62CLD-1, 62CLD-2	●	●	●	●	●
Three-phase undercurrent	37	●	●	●	●	●
Restricted earth fault(REF), low impedance	REF	●	●	●	●	●
Phase undervoltage, 2 elements	27-1, 27-2				●	●
Phase overvoltage, 2 elements	59-1, 59-2				●	●
Phase sequence overvoltage	47				●	●
Ground overvoltage	59G				●	●
Circuit breaker failure	50BF	●	●	●	●	●
Electrically latched/self-resetting trip output, 2 elements	86/94-1, 86/94-2	●	●	●	●	●
Arc flash detection via three lens sensors	AFD-1, AFD-2, AFD-3	●	○	○	○	○

**Table 2. Functions and features (continued)**

Functions and features	Analog Inputs	3 CT	3 CT+ Ground CT	3 CT+ SEF/HIZ CT	3 CT+Ground CT+5 VT	3 CT+SEF/HIZ CT+5 VT
Included = ●, Optional = ○	Order Code	AA	AB	AC	DA	DB
	ANSI					
<b>Control</b>						
Circuit breaker control	52-1	●	●	●	●	●
Autoreclose	79	○	○	○	○	○
<b>Monitoring and Supervision</b>						
Trip circuit monitoring	TCM	●	●	●	●	●
Breaker condition monitoring	52CM-1	●	●	●	●	●
Fuse failure	60				●	●
Open CT secondary monitoring	CCM	●	●	●	●	●
<b>Measurements</b>						
Three-phase currents	IA, IB, IC	●	●	●	●	●
Sequence currents	I1, I2, I0	●	●	●	●	●
Ground current	IG		●	●	●	●
Demand phase currents		●	●	●	●	●
Maximum demand phase currents		●	●	●	●	●
Three-phase voltages	VA, VB, VC				●	●
Sequence voltages	V1, V2, V0				●	●
Ground voltage	VG				●	●
Power, energy, and power factor	P, E, and PF				●	●
<b>Automation &amp; Communications</b>						
10/100BaseT Ethernet (RJ45)		●	●	●	●	●
100BaseFL Ethernet(LC)		○	○	○	○	○
10/100BaseT Ethernet(RJ45) + RS-485(1x4-wire or 2x2-wire) + IRIG-B		○	○	○	○	○
100BaseFL Ethernet(LC) + RS-485(1x4-wire or 2x2-wire) + IRIG-B		○	○	○	○	○
Ethernet 10/100BaseT (RJ45) + configurable RS232/RS485 + [RS485 or serial glass fiber (ST)] + IRIG-B		○	○	○	○	○
<b>Records</b>						
Sequence of events recorder	SER	●	●	●	●	●
Fault recorder	FLR	●	●	●	●	●
Digital fault (waveform) recorder	DFR	●	●	●	●	●

### 3. Protection functions

This IED provides non-directional phase and ground overcurrent, thermal overload, phase unbalance and phase discontinuity protection with optional sensitive earth fault (SEF), high impedance fault detection (HIZ), directional phase, ground and neutral overcurrent and phase, ground (residual), positive sequence and negative sequence undervoltage and overvoltage protection. Also, the IED offers an optional three-pole multishot autoreclose function for utility overhead distribution feeders.

Enhanced with an arc flash detection (AFD), the relay also features three light detection channels for arc fault detection of the circuit breaker, busbar and cable compartment of metal-enclosed switchgear.

The AFD sensor interface is available on the optional communication module. Fast tripping increases personal safety and limits material damage within the switchgear in an arc fault situation.

Add this new paragraph at the end of the section: Figures 1 through 5 show the protection functions available for the two standard configurations and user selected analog inputs within each configuration. See section 23. **Selection and ordering** data for details on the available analog inputs for each standard configuration.

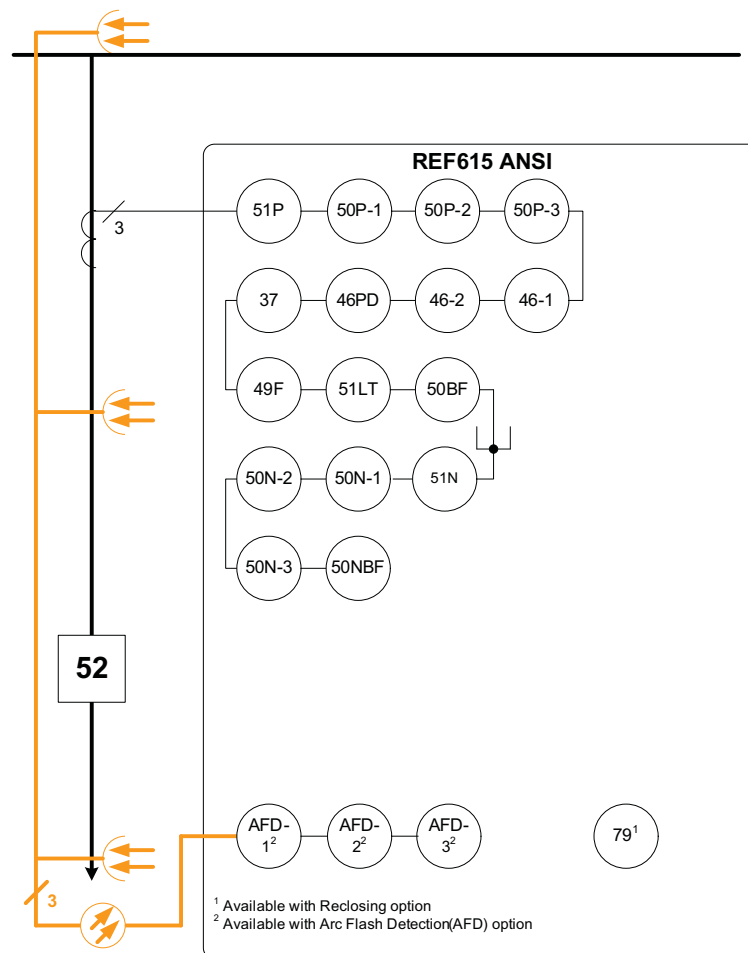

Figure 1. Protection function overview for standard configuration A with analog inputs “AA”

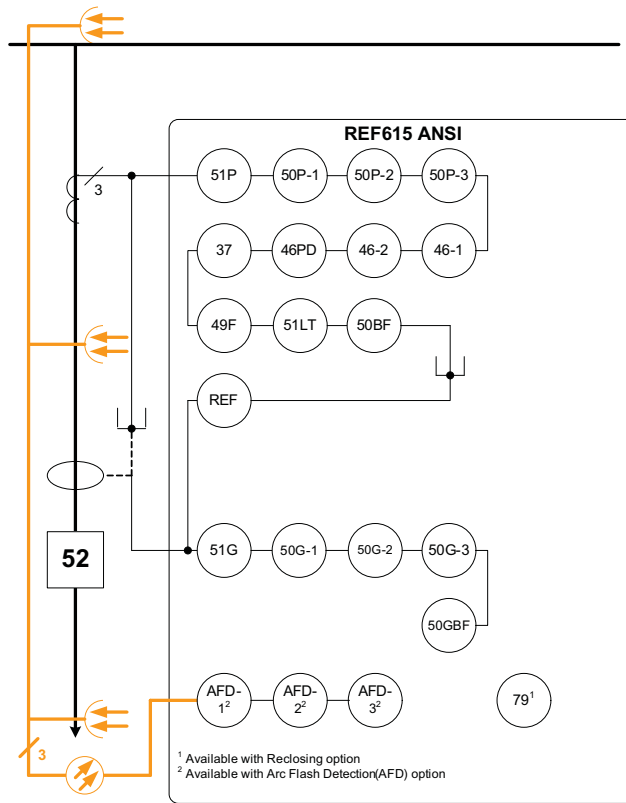

Figure 2. Protection function overview for standard configuration A with analog inputs “AB”

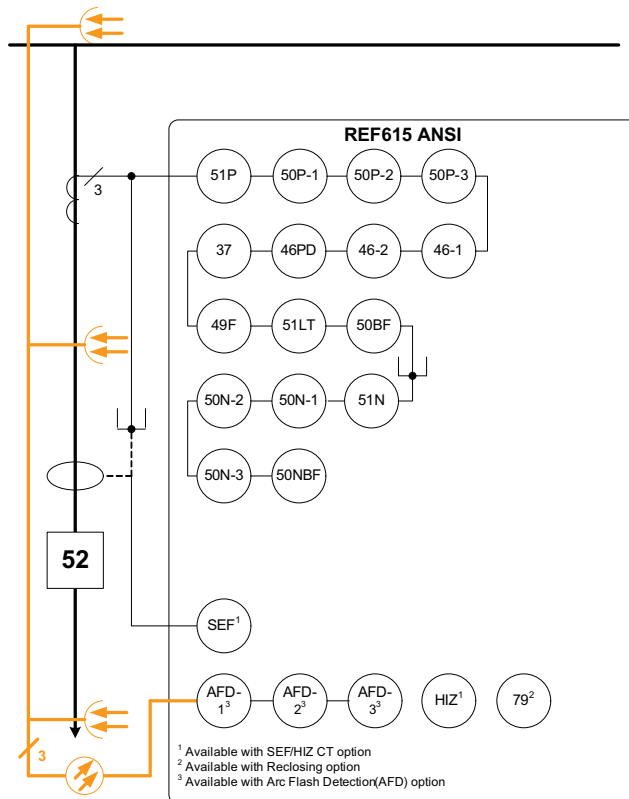

Figure 3. Protection function overview for standard configuration A with analog inputs “AC”

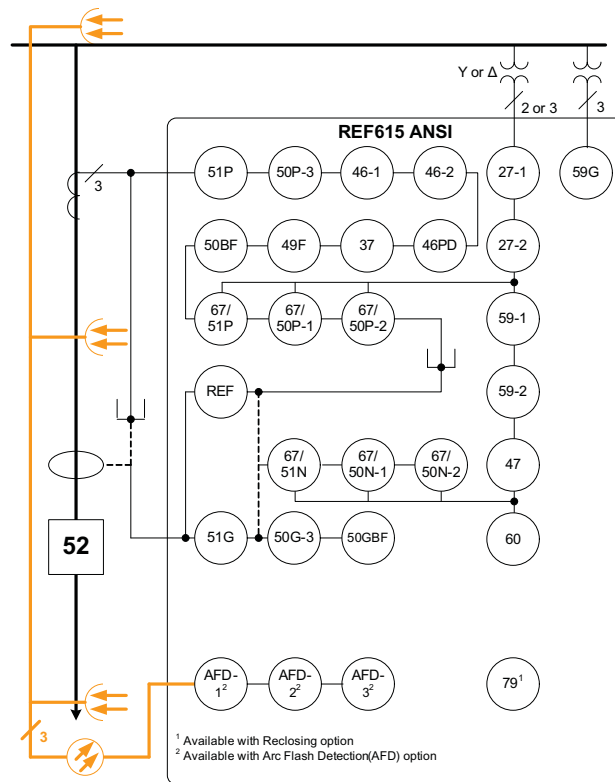

Figure 4. Protection function overview for standard configuration D with analog inputs "DA"

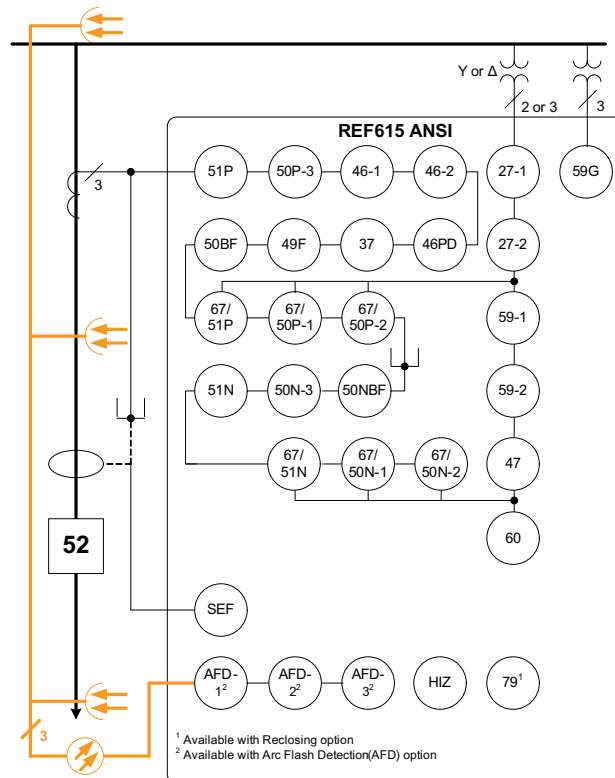

Figure 5. Protection function overview for standard configuration D with analog inputs "DB"



## 4. Application

The REF615 ANSI IED can be conveniently ordered with or without a ground CT input, sensitive earth fault (SEF)/ high impedance (HIZ) CT input or VT inputs to perfectly match available analog inputs for required distribution feeder protection, control and metering. Customer programmable phase and ground CT and VT secondary nominal settings and wide protection setting ranges increase the REF615 flexibility of application and eliminate multiple REF615 order codes. The REF615 ANSI standard

configuration A provides a solid base of overcurrent protection, metering and fault recording functionality for basic protection, control and monitoring of utility and industrial distribution feeders and for simple backup protection in distribution and transmission protection schemes. Included standard is advanced Ethernet communications supporting the IEC61850-8 standard and DNP3.0 Level 2+ and Modbus protocols over TCP/IP and optional reclosing, serial communications and an Arc Flash Detection safety feature are available for this cost-effective configuration.

The REF615 ANSI configuration D includes voltage inputs and all the feature benefits they afford such as numerous phase, ground and sequence undervoltage and overvoltage protection functions and voltage, power, energy and power factor metering standard with the same optional reclosing, serial communications and Arc Flash Detection safety features for this more comprehensive IED configuration.

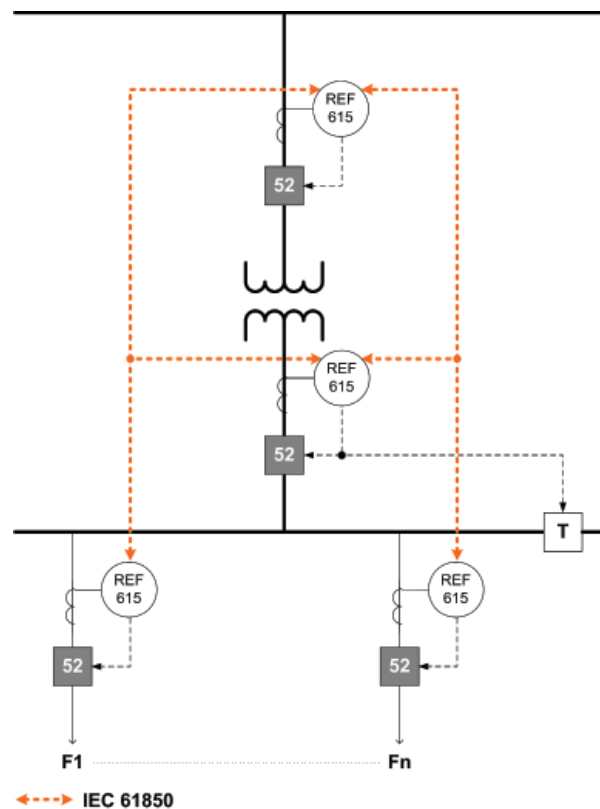

Figure 6. Protection and control applications with standard configuration A

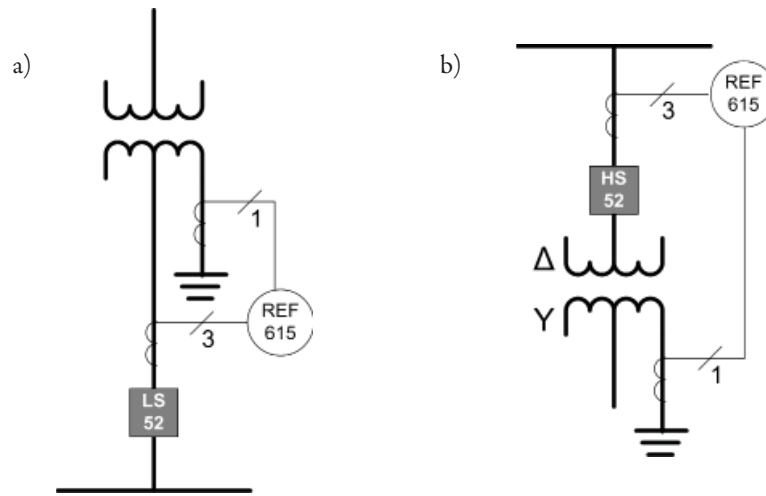

Figure 7. Cost-effective backup protection with standard configuration A for a) bus and b) transformer

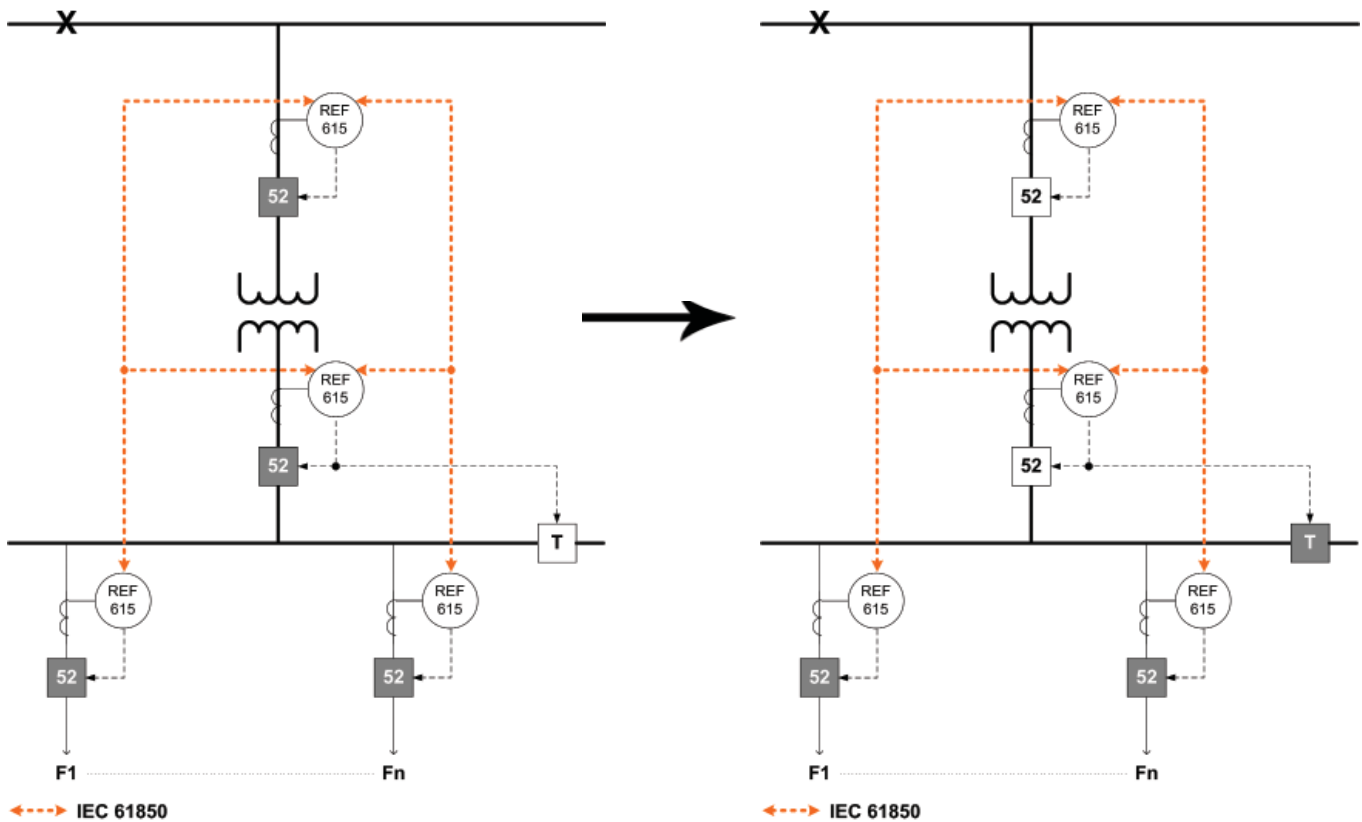

Figure 8. Peer-to-peer relay 'bus transfer' control using IEC61850 GOOSE messaging with standard configuration A

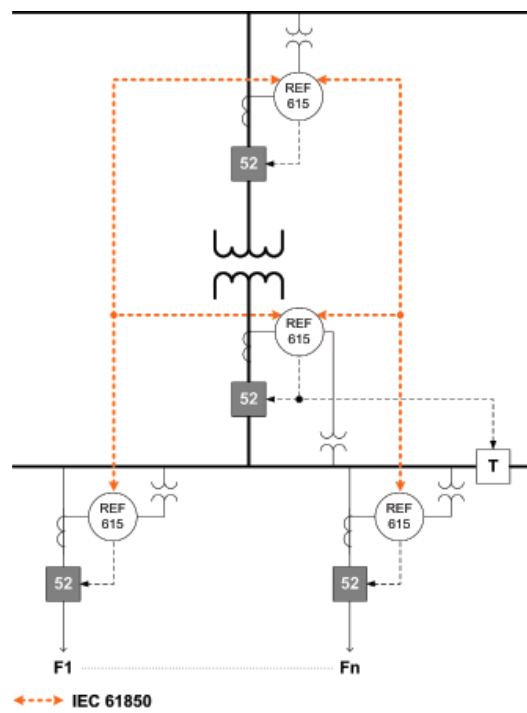

Figure 9. Protection and control applications with standard configuration D

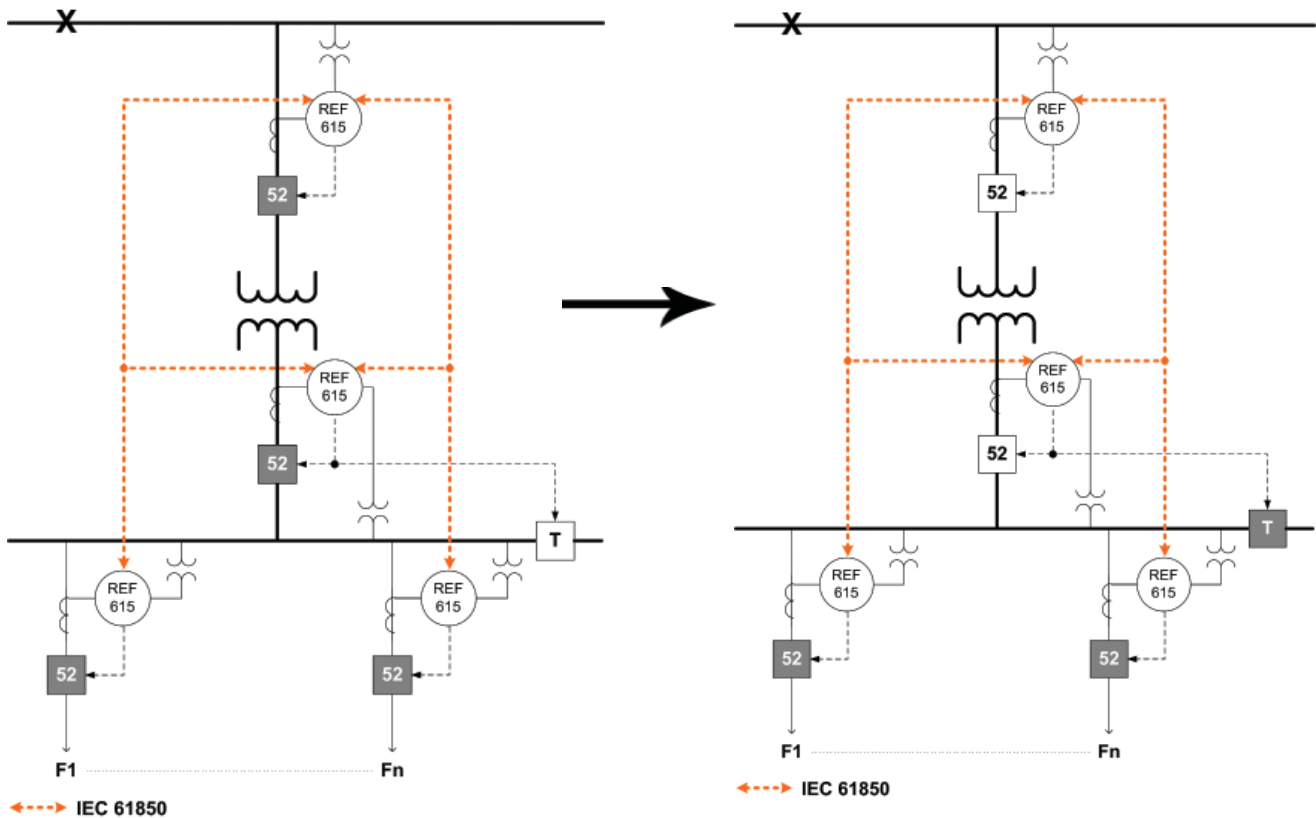

Figure 10. Peer-to-peer relay 'bus transfer' control using IEC61850 GOOSE messaging with standard configuration D

## 5. Supported ABB solutions

ABB's 615 series protection and control IEDs together with the COM600 Station Automation device constitute a genuine IEC 61850 solution for reliable power distribution in utility and industrial power systems. To facilitate and streamline the system engineering ABB's IEDs are supplied with Connectivity Packages containing a compilation of software and IED-specific information including single-line diagram templates, a full IED data model including event and parameter lists. By utilizing the Connectivity Packages the IEDs can be readily configured via the PCM600 Protection and Control IED Manager and integrated with the COM600 Station Automation device or the MicroSCADA Pro network control and management system.

The 615 series IEDs offer native support for the IEC 61850 standard also including horizontal GOOSE messaging. Compared with traditional hard-wired inter-device signaling, peer-to-peer communication over a switched Ethernet LAN offers an advanced and versatile platform for power system protection. Fast software-based communication, continuous supervision of the integrity of the protection and communication system, and inherent flexibility for reconfiguration and upgrades are among the distinctive features of the protection system approach enabled by the full implementation of the IEC 61850 substation automation standard.

At the substation level COM600 utilizes the data content of the design level IEDs to offer enhanced substation level functionality. COM600 features a web-browser based HMI providing a customizable graphical display for visualizing single line mimic diagrams for switchgear design solutions. To enhance personnel safety, the web HMI also enables remote access to substation devices and processes. Furthermore, COM600 can be used as a local data warehouse for technical documentation of the substation and for network data collected by the IEDs. The collected network data facilitates extensive reporting and analyzing of network fault situations using the data historian and event handling features of COM600.

COM600 also features gateway functionality providing seamless connectivity between the substation IEDs and network-level control and management systems such as MicroSCADA Pro and System 800xA.

**Table 3. Supported ABB solutions**

Product	Version
Station Automation COM600	3.4 or later
MicroSCADA Pro	9.2 SP1 or later

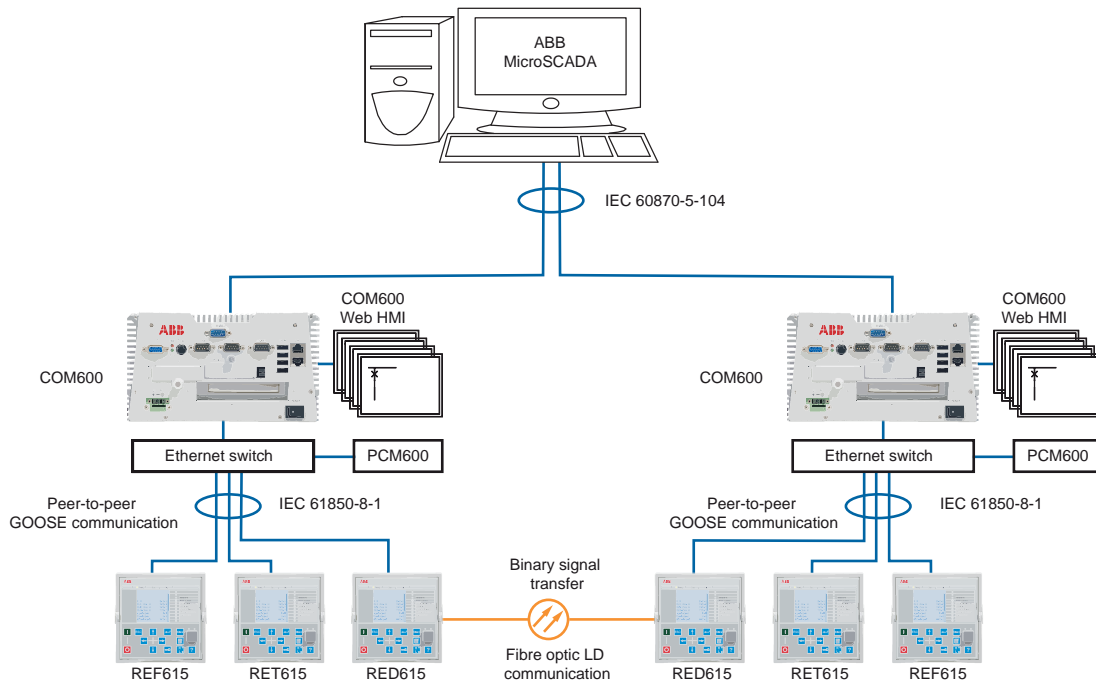

Figure 11. Utility distribution network example using 615 series IEDs, Station Automation COM600 and MicroSCADA Pro

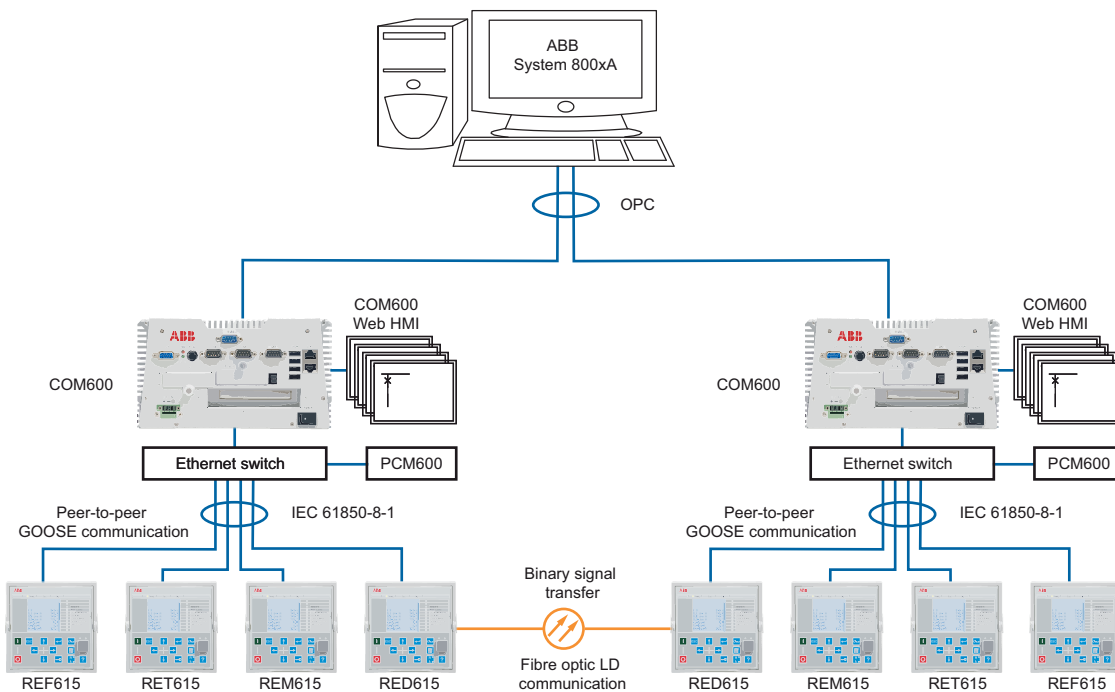

Figure 12. Industrial distribution network example using 615 series IEDs, Station Automation COM600 and System 800xA

---

## 6. Control

---

The relay offers status and control of one circuit breaker with dedicated push-buttons on the front panel local human machine interface (LHMI) for opening and closing of that breaker. Flexible remote breaker control of select-before-trip (SBO) or direct trip is also available with each of the supported DNP3.0 Level 2+, Modbus and IEC 61850 communication protocols. Interlocking schemes required by the application are configured with the signal matrix tool in PCM600 by the application are configured with the Signal Matrix Tool (SMT) of the REF615 user tool PCM600.

---

## 7. Measurements

---

The relay continuously measures the phase currents, the sequence components of the currents and the residual current. If the relay includes the ground ct option, it also measures the ground current, IG. In addition, the relay calculates the demand phase currents over a user-selectable pre-set time frame, the thermal overload of the protected object, and the phase unbalance value as a ratio between the negative sequence and positive sequence currents. With the VT option, phase, ground and sequence voltage measurements plus power, energy and power factor measurements are included.

The values measured can be accessed locally via the user interface on the relay front panel or remotely via the communication interface of the relay. The values can also be accessed locally or remotely using the web-browser based user interface.

---

## 8. Digital fault recorder

---

The relay is provided with a digital fault recorder (DFR) featuring up to four analog and 64 binary signal channels. The analog channels record either the waveform or the trend of the currents measured.

The analog channels can be set to trigger the recording function when the measured value falls below or exceeds the set values. The binary signal channels can

be set to start a recording on the rising or the falling edge of the binary signal or both.

By default, the binary channels are set to record external or internal relay signals, e.g. the pickup or trip signals of the relay stages, or external blocking or control signals. Binary relay signals such as a protection pickup or trip signal, or an external relay control signal over a binary input can be set to trigger the recording. With the VT option, phase and ground voltage waveforms would be available for inclusion in each digital recording.

---

## 9. Events recorder

---

The IED includes a sequence of events recorder (SER) that logs important event activity. To collect sequence-of-events (SER) information, the relay incorporates a memory with a capacity of storing 100 event codes with associated time stamps with associated date and time stamps. The event log facilitates detailed pre- and post-fault analyses of feeder faults and disturbances.

The SER information can be accessed locally via the user interface on the relay front panel or remotely via the communication interface of the relay. The information can further be accessed, either locally or remotely, using the web-browser based user interface.

---

## 10. Fault recorder

---

The relay has the capacity to store the records of 100 fault events. The records enable the user to analyze the four most recent power system events. Each record includes the current values, the Pickup times of the protection blocks, time stamp, etc. The fault recording can be triggered by the pickup signal or the trip signal of a protection block, or by both. The available measurement modes include DFT, RMS and peak-to-peak. In addition, the maximum demand phase currents with date and time stamp are separately stored as recorded data. All 100 records are remotely retrievable via DNP3.0 Level 2+ and Modbus protocols and the four most recent fault records are retrievable and viewable using the front panel HMI, WMHI and PCM600 interfaces using the front panel HMI, web-based WHMI and PCM600 interfaces.

---

## 11. Circuit-breaker condition monitoring

---

For continuous knowledge of the operational availability of the REF615 features, a comprehensive set of monitoring functions to supervise the relay health, the trip circuit and the circuit breaker health is included. The breaker monitoring can include checking the wear and tear of the circuit breaker, the spring charging time of the breaker operating mechanism and the gas pressure of the breaker chambers. The relay also monitors the breaker travel time and the number of circuit breaker (CB) operations to provide basic information for scheduling CB maintenance.

---

## 12. Trip-circuit monitoring

---

The trip-circuit monitoring continuously supervises the availability and operability of the trip circuit. It provides open-circuit monitoring both when the circuit breaker is in its closed and in its open position. It also detects loss of circuit-breaker control voltage.

Local and remote indication are programmable to ensure immediate notification so the necessary steps can be established to correct before the next fault event occurs.

---

## 13. Self-diagnostics

---

The relay's built-in self-diagnostics system continuously monitors the state of the relay hardware and the operation of the relay software. Any fault or malfunction detected will be used for alerting the operator. A permanent relay fault will block the protection functions of the relay to prevent incorrect relay operation.

---

## 14. Fuse failure protection

---

Depending on the chosen standard configuration, the IED includes fuse failure supervision functionality. The fuse failure supervision detects failures between the voltage measurement circuit and the IED. The failures are detected by the negative sequence based algorithm or by the delta voltage and delta current algorithm. Upon the detection of a failure the fuse failure supervision function activates an alarm and blocks voltage-dependent protection functions from unintended operation.

---

## 15. Current circuit supervision

---

Depending on the chosen standard configuration, the IED includes current circuit supervision. Current circuit supervision is used for detecting an open in the current transformer secondary circuits. On detecting an opening circuit, the current circuit supervision function activates an alarm LED and blocks certain protection functions to avoid unintended operation. The current circuit supervision function calculates the sum of the phase currents from the protection cores and compares the sum with the measured single reference current from a core balance current transformer or from separate cores in the phase current transformers.

## 16. Access control

To protect the IED from unauthorized access and to maintain information integrity, the IED is provided with a four-level, role-based authentication system with administrator programmable individual passwords for the viewer, operator, engineer and administrator level. The access control applies to the frontpanel user interface, the web-browser based user interface and the PCM600 tool.

The phase-current and ground current nominal rating of 5 A or 1 A are selected in the relay software. The nominal secondary voltage of the three-phase and ground VT inputs are user programmable.

The binary input turn-on thresholds are programmable from 18...176 V DC by adjusting the relay's parameter settings.

All binary input and output contacts are freely programmable with the signal matrix tool in PCM600 software user tool.

Relay analog input and binary input/output overview:

- Three phase-current inputs
- Optional ground current or SEF/HIZ ct current input
- Optional three-phase and ground VT inputs
- Four, eight with VT inputs, binary inputs standard
- Two NO outputs with trip circuit monitoring
- Three NO outputs
- One Form C output
- One Form C self-check alarm output
- Additional eight binary inputs plus four binary outputs (available as an option)

## 17. Inputs and outputs

The availability of current (ct) and voltage (vt) analog inputs depends upon the standard configuration ordered. Standard and optional binary inputs and outputs (I/O) also depend upon the selected IED configuration. Table 4 details the analog inputs and I/O available for each configuration and analog inputs order code characters.

The phase-current inputs are user programmable for 5 A or 1 A ct secondary nominal rating. The ground ct option is programmable for 5/1 A nominal rating, the SEF/HIZ ct option has a fixed 0.2 A nominal rating. The sensitive earth fault ct option provides SEF protection and includes a separate, independent HIZ protective function for detecting downed conductors.

**Table 4. Inputs and outputs (I/O) overview**

Configuration and analog inputs order code characters	Analog inputs		Binary I/O order code	Binary inputs/outputs	
	CT	VT		BI	BO
AAA	3	0	AA	4	6
AAA	3	0	AB	12 <sup>1)</sup>	10 <sup>1)</sup>
AAA	3	0	AC	18 <sup>1)</sup>	13 <sup>1)</sup>
AAB	4	0	AA	4	6
AAB	4	0	AB	12 <sup>1)</sup>	10 <sup>1)</sup>
AAB	4	0	AC	18 <sup>1)</sup>	13 <sup>1)</sup>
AAC	4	0	AA	4	6
AAC	4	0	AB	12 <sup>1)</sup>	10 <sup>1)</sup>
AAC	4	0	AC	18 <sup>1)</sup>	13 <sup>1)</sup>
DDA	4	5 <sup>1),2)</sup>	DA	16	10
DDB	4	5 <sup>1),2)</sup>	DA	16	10

<sup>1)</sup> Optional

<sup>2)</sup> One of the five inputs is reserved for future applications



## 18. Communications

The relay supports three different communication protocols: IEC 61850, DNP3.0 Level 2+ and Modbus®. Operational information and controls are available through these protocols. Unique communication functionality, for example, peer-to-peer communication between relays is available via the IEC 61850 communication protocol.

The IEC 61850 communication implementation supports all monitoring and control functions. Additionally, parameter setting and disturbance file records can be accessed using the IEC 61850-8-1 protocol. Further, the relay can send and receive binary signals from other relays (peer-to-peer communication) using the IEC61850-8-1 GOOSE profile, where the highest performance class with a total transmission time of 3 ms is supported. The relay can simultaneously report to five different clients - maximum five IEC 61850-8-1 clients, maximum five Modbus clients and maximum one DNP3.0 Level 2+ client with total number not exceeding five.

All communication connectors, except for the front RJ45 connector, are located in the back of the unit on the leftmost card slot. This slot remains in the case when the drawout unit is removed eliminating the need to disconnect communication connections. The relay can be connected to an Ethernet-based communications network via a copper RJ45 (100Base TX) or fiberoptic LC (100Base FX) connector or serial network via the RS-485 option that provides one 4-wire or two 2-wire ports.

Modbus over TCP/IP is supported with the Ethernet communications option selected. Besides standard Modbus functionality such as status and control operations, the relay supports retrieval of time-stamped events, uploading of disturbance files and storing of the latest fault records. For the Modbus TCP connection, a maximum of, five clients can be connected to the relay simultaneously.

DNP3.0 Level 2+ over TCP/IP is also supported with the Ethernet communications card option. Another serial communications option offers programmable RS-232 or RS-485 and fiber-optic (ST) serial ports. Status and control, including breaker trip/close control, operations are supported in the Level 2+ implementation.

Optional serial (RS-232/RS-485) communication interfaces are available that support user programmable protocols of DNP3.0 Level 2+ and Modbus RTU/ASCII. Another serial communications option offers programmable RS-232 or RS-485 and fiber-optic (ST) serial ports. All serial communication card options include an Ethernet communications port and an IRIG-B port for dedicated time synchronization network connections.

The relay supports the time synchronization with a time-stamping resolution of +/-1 ms:

Ethernet based:

- SNTP (primary and secondary server support)

**Table 5. Supported station communication interfaces and protocols**

Interfaces/Protocols	Ethernet		Serial	
	100BASE-TX (RJ45)	100BASE-FX (LC)	RS-232/RS-485	Fiber-optic (ST)
DNP3.0 Level 2+ over TCP/IP	•	•	-	-
Modbus over TCP/IP	•	•	-	-
IEC 61850-8-1	•	•	-	-
SNTP	•	•	-	-
FTP	•	•	-	-
DNP3.0 Level 2+ serial	-	-	•	•
Modbus RTU/ASCII	-	-	•	•
IRIG-B time synchronization	-	-	•	•

• = supported

## 19. Technical data

**Table 6. Dimensions**

Description	Value	
Width	frame	7.08" (179.8 mm)
	case	6.46" (164 mm)
Height	frame	6.97 (177 mm), 4U
	case	6.30" (160 mm)
Depth	case	7.64" (194 mm)
Weight	relay	7.72 lbs. (3.5 kg)
	draw-out unit	3.97 lbs. (1.8 kg)

**Table 7. Power supply**

Description	Type 1		Type 2
V nominal ( $V_n$ )	100, 110, 120, 220, 240 V AC, 60 and 50 Hz 48, 60, 110, 125, 220, 250 V DC		24, 30, 48, 60 V DC
$V_n$ variation	38...110% of $V_n$ (38...264 V AC) 80...120% of $V_n$ (38.4...300 V DC)		50...120% of $V_n$ (12...72 V DC)
Start-up threshold			19.2 V DC (24 V DC * 80%)
Burden of auxiliary voltage supply under quiescent ( $P_q$ )/operating condition	250 V DC ~8.5 W (nominal) / ~14.1 W (maximum) 240 V AC ~10.2 W (nominal) / ~16.1 W (maximum)		60 V DC ~6.7 W (nominal) / ~12.9 W (maximum)
Ripple in the DC auxiliary voltage	Max 12% of the DC value (at frequency of 100 Hz)		
Maximum interruption time in the auxiliary DC voltage without resetting the relay	110 V DC: 84 ms	110 V AC: 116 ms	48 V DC: 68 ms
Fuse type	T4A/250 V		

**Table 8. Analog inputs**

Description		Value	
Rated frequency		60/50 Hz $\pm$ 5 Hz	
Current inputs	Rated current, $I_n$	5/1 A <sup>1)</sup>	0.2 A <sup>2)</sup>
	Thermal withstand capability:		
	• Continuously	20 A	4 A
	• For 1 s	500 A	100 A
	• For 10 s	100 A	25 A
Dynamic current withstand:			
• Half-wave value	1250 A	250 A	
Input impedance	<20 m $\Omega$	<100 m $\Omega$	
Voltage input	Rated voltage $V_n$	100 V/ 110 V/ 115 V/ 120 V (Parametrization)	
	Voltage withstand:		
	• Continuous	2 x $V_n$ (240 V)	
	• For 10 s	3 x $V_n$ (360 V)	
Burden at rated voltage	<0.05 VA		

<sup>1)</sup> Phase and ground current inputs

<sup>2)</sup> Sensitive earth fault (SEF)/high impedance (HIZ) detection current input

**Table 9. Measuring range**

Description	Value
Measured currents on phases IA, IB and IC as multiples of the rated currents of the analog inputs	0... 50 x $I_n$
Ground current as a multiple of the rated current of the analog input	0... 50 x $I_n$

**Table 10. Binary inputs**

Description	Value
Operating range	$\pm$ 20 % of the rated voltage
Rated voltage	24...250 V DC
Current drain	1.6...1.9 mA
Power consumption	31.0...570 mW
Threshold voltage	18...176 V DC
Reaction time	3 ms

**Table 11. Signal outputs (SO) [Typical operation time: 5...8 ms]**

Description	Value
Rated voltage	250 V AC/DC
Continuous carry	5 A
Make and carry for 3.0 s	10 A
Make and carry 0.5 s	15 A
Breaking capacity when the control-circuit time constant $L/R < 40$ ms, at 48/110/220 V DC	1 A/0.25 A/0.15 A
Minimum contact load	100 mA at 24 V AC/DC

**Table 12. Self-diagnostics alarm signal output (SO) [Typical operation time: 5...8 ms]**

Description	Value
Rated voltage	250 V AC/DC
Continuous contact carry	5 A
Make and carry for 3.0 s	10 A
Make and carry 0.5 s	15 A
Breaking capacity when the control-circuit time constant L/R < 40 ms, at 48/110/220 V DC	1 A/0.25 A/0.15 A
Minimum contact load	100 mA at 24 V AC/DC

**Table 13. Double-pole power output (PO) relays with TCM [Typical operation time: 8...11 ms]**

Rated voltage	250 V AC/DC
Continuous contact carry	8 A
Make and carry for 3.0 s	15 A
Make and carry 0.5 s	30 A
Breaking capacity when the control-circuit time constant L/R < 40 ms, at 48/110/220 V DC (two contacts connected in series)	5 A/3 A/1 A
Minimum contact load	100 mA at 24 V AC/DC
Trip-circuit monitoring (TCM):	
• Control voltage range	20...250 V AC/DC
• Current drain through the monitoring circuit	~1.5 mA
• Minimum voltage over the TCM contact	20 V AC/DC (15...20 V)

**Table 14. Single-pole power output (PO) relays [Typical operation time: 8...11 ms]**

Description	Value
Rated voltage	250 V AC/DC
Continuous contact carry	8 A
Make and carry for 3.0 s	15 A
Make and carry 0.5 s	30 A
Breaking capacity when the control-circuit time constant L/R < 40 ms, at 48/110/220 V DC	5 A/3 A/1 A
Minimum contact load	100 mA at 24 V AC/DC

**Table 15. Lens sensor and optic fiber for arc flash detection (AFD)**

Description	Value
Fibre-optic cable including lens	1.5 m, 3.0 m or 5.0 m
Normal service temperature range of the lens	-40° to +212° F (-40° to 100° C)
Maximum service temperature range of the lens, max 1 h	+284° F (+140° C)
Minimum permissible bending radius of the connection fibre	3.94" (100 mm)

**Table 16. Degree of protection of flush-mounted relay**

Description	Value
Front side	IP 54
Back side, connection terminals	IP 20

**Table 17. Environmental conditions**

Description	Value
Continuous operating temperature range	-25 C to +55° C
Short-term operating temperature range	-40 C to +85° C (<16 h) <sup>1) 2)</sup>
Relative humidity	<93%, non-condensing
Atmospheric pressure	12.47 - 15.37 psi (86 - 106 kPa)
Altitude	up to 6561 ft. (2000 m)
Transport and storage temperature range	-40...+85°C

<sup>1)</sup> Degradation in MTBF and LHMI performance outside continuous operating temperature range

<sup>2)</sup> For relays with an LC communications interface, the maximum operating temperature is +70° C

**Table 18. Environmental tests**

Description	Type test value	Reference
Dry heat test (humidity <50%)	<ul style="list-style-type: none"> <li>• 96 h at +55°C</li> <li>• 16 h at +85°C<sup>1)</sup></li> </ul>	IEC 60068-2-2
Dry cold test	<ul style="list-style-type: none"> <li>• 96 h at -25°C</li> <li>• 16 h at -40°C</li> </ul>	IEC 60068-2-1
Damp heat test, cyclic	• 6 cycles (12 h + 12 h) at +25°C...+55°C, humidity >93%	IEC 60068-2-30
Storage test	<ul style="list-style-type: none"> <li>• 96 h at -40°C</li> <li>• 96 h at +85°C</li> </ul>	IEC 60068-2-48

<sup>1)</sup> For IEDs with an LC communication interface the maximum operating temperature is +70° C

**Table 19. Electromagnetic compatibility tests**

The EMC immunity test level meets the requirements listed below:		
Description	Type test value	Reference
1 MHz burst disturbance test, class III: <ul style="list-style-type: none"> <li>• Common mode</li> <li>• Differential mode</li> </ul>	2,5 kV 1,0 kV	According to IEC 61000-4-18 and IEC 60255-22-1, level 3
Electrostatic discharge test <ul style="list-style-type: none"> <li>• Contact discharge</li> <li>• Air discharge</li> </ul>	6 kV 8 kV	According to IEC 61000-4-2, IEC 60255-22-2, level 3
Radio frequency interference tests: <ul style="list-style-type: none"> <li>• Conducted, common mode</li> <li>• Radiated, amplitude-modulated</li> <li>• Radiated, pulse-modulated</li> </ul>	10 V (emf), f = 150 kHz...80 MHz  10 V/m (rms), f=80...1000 MHz and f=1.4...2.7 GHz  10 V/m, f=900 MHz	According to IEC 61000-4-6 and IEC 60255-22-6, level 3  According to IEC 61000-4-3 and IEC 60255-22-3, level 3  According to the ENV 50204 and IEC 60255-22-3, level 3
Fast transient disturbance tests: <ul style="list-style-type: none"> <li>• Signal outputs, binary inputs, IRF</li> <li>• Other ports</li> </ul>	2 kV 4 kV	According to IEC 61000-4-4 and IEC 60255-22-4, class B
Surge immunity test: <ul style="list-style-type: none"> <li>• Binary inputs</li> <li>• Communication</li> <li>• Other ports</li> </ul>	2 kV, line-to-earth 1kV, line-to-line 1 kV, line-to-earth 4 kV, line-to-earth 2 kV, line-to-line	According to IEC 61000-4-5 and IEC 60255-22-5, level 4/3
Power frequency (50 Hz) magnetic field: <ul style="list-style-type: none"> <li>• Continuous</li> </ul>	300 A/m	According to IEC 61000-4-8, level 5
Power frequency immunity test: <ul style="list-style-type: none"> <li>• Common mode</li> <li>• Differential mode</li> </ul>	300 V rms 150 V rms	According to IEC 60255-22-7, class A
Voltage dips and short interruptions	30%/10 ms 60%/100 ms 60%/1000 ms >95%/5000 ms	According to IEC 61000-4-11

**Table 19. Electromagnetic compatibility tests (continued)**

The EMC immunity test level meets the requirements listed below:	
Description	Value
Electromagnetic emission tests:	According to the EN 55011, class A and IEC60255-25
<ul style="list-style-type: none"> <li>Conducted, RF emission (mains terminal)</li> </ul>	
0.15...0.50 MHz	< 79 dB( $\mu$ V) quasi peak < 66 dB( $\mu$ V) average
0.5...30 MHz	< 73 dB( $\mu$ V) quasi peak < 60 dB( $\mu$ V) average
<ul style="list-style-type: none"> <li>Radiated RF emission</li> </ul>	
0...230 MHz	< 40 dB( $\mu$ V/m) quasi peak, measured at 10 m distance
230...1000 MHz	< 47 dB( $\mu$ V/m) quasi peak, measured at 10 m distance

**Table 20. Insulation tests**

Description	Value
Dielectric tests:	According to IEC 60255-5
<ul style="list-style-type: none"> <li>Test voltage</li> </ul>	2 kV, 50 Hz, 1 min 500 V, 50 Hz, 1min, communication
Impulse voltage test:	According to IEC 60255-5
<ul style="list-style-type: none"> <li>Test voltage</li> </ul>	5 kV, unipolar impulses, waveform 1.2/50 $\mu$ s, source energy 0.5 J 1 kV, unipolar impulses, waveform 1.2/50 $\mu$ s, source energy 0.5 J, communication
Insulation resistance measurements	According to IEC 60255-5
<ul style="list-style-type: none"> <li>Isolation resistance</li> </ul>	>100 M $\Omega$ , 500 V DC
Protective bonding resistance	According to IEC 60255-27
<ul style="list-style-type: none"> <li>Resistance</li> </ul>	<0.1 $\Omega$ (60 s)

**Table 21. Mechanical tests**

Description	Value
Vibration tests (sinusoidal)	According to IEC 60255-21-1, class 2
Shock and bump test	According to IEC 60255-21-2, class 2

**Table 22. EMC Compliance**

Description	Reference
EMC directive	2004/108/EC
Standard	EN 50263 (2000) EN 60255-26 (2007)



**Table 23. Product safety**

Complies with the LV directive 2006/95/EC

Standards	EN 60255-27 (2005), EN 60255-6 (1994)
-----------	--

**Table 24. RoHS compliance**

Complies with the RoHS directive 2002/95/EC

**Table 25. Ethernet interfaces**

Ethernet interface	Protocol	Cable	Data transfer rate
Front	TCP/IP protocol	Standard Ethernet CAT5 crossover cable with RJ-45 connector	10 MBits/s
Rear	TCP/IP protocol	Shielded twisted pair CAT 5e cable with RJ-45 connector or fibre-optic cable with LC connector	100 MBits/s

## Protection functions

**Table 26. Three-phase non-directional overcurrent protection (50P/51P)**

Characteristic		Value		
Pickup accuracy	51P	Depending on the frequency of the current measured: $f_n \pm 2\text{Hz}$		
		$\pm 1.5\%$ of the set value or $\pm 0.002 \times I_n$		
	50P-1, 50P-2 and 50P-3	$\pm 1.5\%$ of set value or $\pm 0.002 \times I_n$ (at currents in the range of $0.1 \dots 10 \times I_n$ ) $\pm 5.0\%$ of the set value (at currents in the range of $10 \dots 40 \times I_n$ )		
Pickup time <sup>1)2)</sup>		Minimum	Typical	Maximum
	50P-3: $I_{\text{Fault}} = 2 \times \text{set Pickup range}$	16 ms	19 ms	23 ms
	$I_{\text{Fault}} = 10 \times \text{set Pickup range}$	11 ms	12 ms	14 ms
	50P-1, 50P-2 and 51P: $I_{\text{Fault}} = 2 \times \text{set Pickup range}$	22 ms	24 ms	25 ms
Reset time		< 40 ms		
Reset ratio		Typical 0.96		
Retardation time		< 30 ms		
Trip time accuracy in definite time mode		$\pm 1.0\%$ of the set value or $\pm 20$ ms		
Trip time accuracy in inverse time mode		$\pm 5.0\%$ of the theoretical value or $\pm 20$ ms <sup>3)</sup>		
Suppression of harmonics		RMS: No suppression DFT: -50dB at $f = n \times f_n$ , where $n = 2, 3, 4, 5, \dots$ Peak-to-Peak: No suppression P-to-P+backup: No suppression		

<sup>1)</sup> Set Operate delay time = 0,02 s, Operate curve type = ANSI definite time, Measurement mode = default (depends on stage), current before fault =  $0.0 \times I_n$ ,  $f_n = 50$  Hz, fault current in one phase with nominal frequency injected from random phase angle, results based on statistical distribution of 1000 measurements

<sup>2)</sup> Includes the delay of the signal output contact

<sup>3)</sup> Maximum Pickup range =  $2.5 \times I_n$ , Pickup range multiples in range of 1.5 to 20

**Table 27. Three-phase non-directional overcurrent protection (50P/51P) main settings**

Parameter	Function	Value (Range)	Step
Pickup range	51P	$0.05 \dots 5.00 \times I_n$	0.01
	50P-1, 50P-2	$0.10 \dots 40.00 \times I_n$	0.01
	50P-3	$1.00 \dots 40.00 \times I_n$	0.01
Time multiplier	51P	0.8...10.0	0.05
	50P-1, 50P-2	0.05...15.00	0.05
Definite time delay	51P	40...200000 ms	10
	50P-1, 50P-2	40...200000 ms	10
	50P-3	20...200000 ms	10
Operating curve type <sup>1)</sup>	51P	Definite or inverse time Curve type: 1, 2, 3, 4, 5, 6, 7, 8, 9, 10, 11, 12, 13, 14, 15, 17, 18, 19	
	50P-1, 50P-2	Definite or inverse time Curve type: 1, 3, 5, 9, 10, 12, 15, 17	
	50P-3	Definite time	

<sup>1)</sup> For further reference please refer to the Operating characteristics table at the end of the Technical data chapter

**Table 28. Three-phase directional overcurrent protection (67/51P, 67/50P-1, 67/50P-2)**

Characteristic		Value		
Pickup accuracy		Depending on the frequency of the current/ voltage measured: $f_n \pm 2\text{Hz}$		
	67/51P, 67/50P-1	Current: $\pm 1.5\%$ of the set value or $\pm 0.002 \times I_n$ Voltage: $\pm 1.5\%$ of the set value or $\pm 0.002 \times U_n$ Phase angle: $\pm 2^\circ$		
	67/50P-2	Current: $\pm 1.5\%$ of set value or $\pm 0.002 \times I_n$ (at currents in the range of $0.1 \dots 10 \times I_n$ ) $\pm 5.0\%$ of set value (at currents in the range of $10 \dots 40 \times I_n$ ) Voltage: $\pm 1.5\%$ of the set value or $\pm 0.002 \times U_n$ Phase angle: $\pm 2^\circ$		
Pickup time <sup>1) 2)</sup>		Minimum	Typical	Maximum
	$I_{\text{Fault}} = 2.0 \times \text{set Pickup range}$	37 ms	40 ms	42 ms
Reset time	< 40 ms			
Reset ratio	Typical 0.96			
Retardation time	< 35 ms			
Trip time accuracy in definite time mode	$\pm 1.0\%$ of the set value or $\pm 20$ ms			
Trip time accuracy in inverse time mode	$\pm 5.0\%$ of the theoretical value or $\pm 20$ ms <sup>3)</sup>			
Suppression of harmonics	DFT: -50dB at $f = n \times f_n$ , where $n = 2, 3, 4, 5, \dots$			

<sup>1)</sup> Measurement mode and Pol quantity = default, current before fault =  $0.0 \times I_n$ , voltage before fault  $1.0 \times U_n$ ,  $f_n = 50$  Hz, fault current in one phase with nominal frequency injected from random phase angle, results based on statistical distribution of 1000 measurements

<sup>2)</sup> Includes the delay of the signal output contact

<sup>3)</sup> Maximum Pickup range =  $2.5 \times I_n$ , Pickup range multiples in range of 1.5 to 20

**Table 29. Three-phase directional overcurrent protection (67/51P, 67/50P-1, 67/50P-2) main settings**

Parameter	Function	Value (Range)	Step
Pickup range	67/51P, 67/50P-1	$0.05 \dots 5.00 \times I_n$	0.01
	67/50P-2	$0.10 \dots 40.00 \times I_n$	0.01
Time multiplier	67/51P, 67/50P-1, 67/50P-2	0.05...15.00	0.05
Definite time delay	67/51P, 67/50P-1, 67/50P-2	40...200000 ms	10
Directional mode	67/51P, 67/50P-1, 67/50P-2	1 = Non-directional 2 = Forward 3 = Reverse	
Characteristic angle	67/51P, 67/50P-1, 67/50P-2	-179...180 degrees	1
Operating curve type <sup>1)</sup>	67/51P, 67/50P-1	Definite or inverse time Curve type: 1, 2, 3, 4, 5, 6, 7, 8, 9, 10, 11, 12, 13, 14, 15, 17, 18, 19	
	67/50P-2	Definite or inverse time Curve type: 1, 3, 5, 9, 10, 12, 15, 17	

<sup>1)</sup> For further reference please refer to the Operating characteristics table at the end of the Technical data chapter

**Table 30. Non-directional ground fault protection (50N, 51N, 50G, 51G)**

Characteristic		Value		
Pickup accuracy		Depending on the frequency of the current measured: $f_n \pm 2\text{Hz}$		
	51N/51G	$\pm 1.5\%$ of the set value or $\pm 0.002 \times I_n$		
	50N-1, 50N-2, 50G-1, 50G-2 and 50N-3, 50G-3	$\pm 1.5\%$ of set value or $\pm 0.002 \times I_n$ (at currents in the range of $0.1 \dots 10 \times I_n$ ) $\pm 5.0\%$ of the set value (at currents in the range of $10 \dots 40 \times I_n$ )		
Pickup time <sup>1) 2)</sup>		Minimum	Typical	Maximum
	50N-3, 50G-3: $I_{\text{Fault}} = 2 \times \text{set Pickup range}$ $I_{\text{Fault}} = 10 \times \text{set Pickup range}$	16 ms	19 ms	23 ms
		11 ms	12 ms	14 ms
	50N-1, 50N-2, 50G-1, 50G-2 and 51N/51G: $I_{\text{Fault}} = 2 \times \text{set Pickup range}$	22 ms	24 ms	25 ms
Reset time	< 40 ms			
Reset ratio	Typical 0.96			
Retardation time	< 30 ms			
Trip time accuracy in definite time mode	$\pm 1.0\%$ of the set value or $\pm 20$ ms			
Trip time accuracy in inverse time mode	$\pm 5.0\%$ of the theoretical value or $\pm 20$ ms <sup>3)</sup>			
Suppression of harmonics	RMS: No suppression DFT: -50dB at $f = n \times f_n$ , where $n = 2, 3, 4, 5, \dots$ Peak-to-Peak: No suppression			

1) Measurement mode = default (depends on stage), current before fault =  $0.0 \times I_n$ ,  $f_n = 50$  Hz, earth-fault current with nominal frequency injected from random phase angle, results based on statistical distribution of 1000 measurements

2) Includes the delay of the signal output contact

3) Maximum Pickup range =  $2.5 \times I_n$ , Pickup range multiples in range of 1.5 to 20

**Table 31. Non-directional ground fault protection (50N, 51N, 50G, 51G) main settings**

Parameter	Function	Value (Range)	Step
Pickup range	51N/51G	$0.010 \dots 5.000 \times I_n$	0.005
	50N-1, 50N-2, 50G-1, 50G-2	$0.10 \dots 40.00 \times I_n$	0.01
	50N-3, 50G-3	$1.00 \dots 40.00 \times I_n$	0.01
Time multiplier	51N/51G	0.05...15.00	0.05
	50N-1, 50N-2, 50G-1, 50G-2	0.05...15.00	0.05
Definite time delay	51N/51G	40...200000 ms	10
	50N-1, 50N-2, 50G-1, 50G-2	40...200000 ms	10
	50N-3, 50G-3	20...200000 ms	10
Operating curve type <sup>1)</sup>	51N/51G	Definite or inverse time Curve type: 1, 2, 3, 4, 5, 6, 7, 8, 9, 10, 11, 12, 13, 14, 15, 17, 18, 19	
		50N-1, 50N-2, 50G-1, 50G-2	Definite or inverse time Curve type: 1, 3, 5, 9, 10, 12, 15, 17
	50N-3, 50G-3	Definite time	

<sup>1)</sup> For further reference please refer to the Operating characteristics table at the end of the Technical data chapter

**Table 32. Directional ground fault protection (67/51N, 67/50N-1, 67/50N-2)**

Characteristic		Value		
Pickup accuracy		Depending on the frequency of the current measured: $f_n \pm 2\text{Hz}$		
	67/51N, 67/50N-1	Current: $\pm 1.5\%$ of the set value or $\pm 0.002 \times I_n$ Voltage: $\pm 1.5\%$ of the set value or $\pm 0.002 \times U_n$ Phase angle: $\pm 2^\circ$		
	67N/50N-2	Current: $\pm 2\%$ of the set value or $\pm 0.003 \times I_n$ (at currents in the range of $0.1 \dots 10 \times I_n$ ) $\pm 5.0\%$ of the set value (at currents in the range of $10 \dots 40 \times I_n$ ) Voltage: $\pm 1.5\%$ of the set value or $\pm 0.01 \times U_n$ Phase angle: $\pm 2^\circ$		
Pickup time <sup>1)2)</sup>		Minimum	Typical	Maximum
	67N/51N, 67N/50N-1 and 67N/50N-2: $I_{\text{Fault}} = 2 \times \text{set Pickup range}$	61 ms	64 ms	66 ms
Reset time		< 40 ms		
Reset ratio		Typical 0.96		
Retardation time		< 30 ms		
Trip time accuracy in definite time mode		$\pm 1.0\%$ of the set value or $\pm 20$ ms		
Trip time accuracy in inverse time mode		$\pm 5.0\%$ of the theoretical value or $\pm 20$ ms <sup>3)</sup>		
Suppression of harmonics		RMS: No suppression DFT: -50dB at $f = n \times f_n$ , where $n = 2, 3, 4, 5, \dots$ Peak-to-Peak: No suppression		

<sup>1)</sup> Set Definite time delay = 0,06 s, Inverse-time (IDMT) and definite-time (DT) curves = ANSI definite time, Measurement mode = default (depends on stage), current before fault =  $0.0 \times I_n$ ,  $f_n = 50$  Hz, earth-fault current with nominal frequency injected from random phase angle, results based on statistical distribution of 1000 measurements

<sup>2)</sup> Includes the delay of the signal output contact

<sup>3)</sup> Maximum Pickup range =  $2.5 \times I_n$ , Pickup range multiples in range of 1.5 to 20

**Table 33. Directional ground fault protection (67N/51N and 67N, 50N-1) main settings**

Parameter	Function	Value (Range)	Step
Pickup range	67N/51N, 67N/50N-1	0.010...5.000 x I <sub>n</sub>	0.005
	67N/50N-2	0.10...40.00 x I <sub>n</sub>	0.01
Directional mode	67N/51N, 67N/ 50N-1 and 67N/50N-2	1=Non-directional 2=Forward 3=Reverse	
Time multiplier	67N/51N, 67N/50N-1	0.05...15.00	0.05
	67N/50N-2	0.05...15.00	0.05
Definite time delay	67N/51N, 67N/50N-1	60...200000 ms	10
	67N/50N-2	60...200000 ms	10
Operating curve type <sup>1)</sup>	67N/51N, 67N/50N-1	Definite or inverse time Curve type: 1, 2, 3, 4, 5, 6, 7, 8, 9, 10, 11, 12, 13, 14, 15, 17, 18, 19	
	67N/50N-2	Definite or inverse time Curve type: 1, 3, 5, 15, 17	
Operation mode	67N/51N, 67N/50N-1 and 67N/50N-2	1=Phase angle 2=I <sub>0</sub> Sin 3=I <sub>0</sub> Cos 4=Phase angle 80 5=Phase angle 88	

**Table 34. Three-phase non-directional long time overcurrent protection (51LT)**

Characteristic		Value		
Pickup accuracy	51LT	Depending on the frequency of the current measured: f <sub>n</sub> ±2Hz ±1.5% of the set value or ±0.002 x I <sub>n</sub>		
Pickup time <sup>1) 2)</sup>	51LT: I <sub>Fault</sub> = 2 x set Pickup value	Minimum	Typical	Maximum
		22 ms	24 ms	25 ms
Reset time		< 40 ms		
Reset ratio		Typical 0.96		
Retardation time		< 30 ms		
Trip time accuracy in definite time mode		±1.0% of the set value or ±20 ms		
Trip time accuracy in inverse time mode		±5.0% of the theoretical value or ±20 ms <sup>4)</sup>		
Suppression of harmonics		RMS: No suppression DFT: -50dB at f = n x f <sub>n</sub> , where n = 2, 3, 4, 5,... Peak-to-Peak: No suppression P-to-P+backup: No suppression		

<sup>1)</sup> Set Operate delay time = 0.02 s, Operate curve type = ANSI definite time, Measurement mode = default (depends on element), current before fault = 0.0 x I<sub>n</sub>, f<sub>n</sub> = 60 Hz, fault current in one phase with nominal frequency injected from random phase angle, results based on statistical distribution of 1000 measurements

<sup>2)</sup> Includes the delay of the signal output contact

<sup>3)</sup> Includes the delay of the heavy-duty output contact

<sup>4)</sup> Maximum Pickup value = 2.5 x I<sub>n</sub>, Pickup value multiples in range of 1.5 to 20

**Table 35. Three-phase non-directional long time overcurrent protection (51LT) main settings**

Parameter	Function	Value (Range)	Step
Pickup range	51LT	0.05 - 5.00 x I <sub>n</sub>	0.01
Time multiplier	51LT	0.10...15.00 <sup>1</sup>	0.01
Definite time delay	51LT	0.020...200.00 <sup>1</sup> s	0.001
Operating curve type	51LT	Definite or inverse-time curve type: 6, 7, 14, 15, 17	

<sup>1</sup> Embedded 10x factor in time multiplier to achieve 'very long-time' curve characteristic

**Table 36. Three-phase overvoltage protection (59)**

Characteristic	Value			
Pickup accuracy	Depending on the frequency of the voltage measured: f <sub>n</sub> ±2Hz ±1.5% of the set value or ±0.002 x U <sub>n</sub>			
Pickup time <sup>1)2)</sup>	U <sub>Fault</sub> = 1.1 x set Pickup range	Minimum 22 ms	Typical 24 ms	Maximum 26 ms
Reset time	< 40 ms			
Reset ratio	Depends on the Relative hysteresis			
Retardation time	< 35 ms			
Trip time accuracy in definite time mode	±1.0% of the set value or ±20 ms			
Trip time accuracy in inverse time mode	±5.0% of the theoretical value or ±20 ms <sup>3)</sup>			
Suppression of harmonics	DFT: -50dB at f = n x f <sub>n</sub> , where n = 2, 3, 4, 5,...			

<sup>1)</sup> Pickup range = 1.0 x U<sub>n</sub>, Voltage before fault 0.9 x U<sub>n</sub>, f<sub>n</sub> = 50 Hz, overvoltage in one phase-to-phase with nominal frequency injected from random phase angle, results based on statistical distribution of 1000 measurements

<sup>2)</sup> Includes the delay of the signal output contact

<sup>3)</sup> Maximum Pickup range = 1.20 x U<sub>n</sub>, Pickup range multiples in range of 1.10 to 2.00

**Table 37. Three-phase overvoltage protection (59) main settings**

Parameter	Function	Value (Range)	Step
Pickup range	59	0.05...1.60 x U <sub>n</sub>	0.01
Time multiplier	59	0.05...15.00	0.05
Definite time delay	59	40...300000 ms	10
Operating curve type <sup>1)</sup>	59	Definite or inverse time Curve type: 5, 15, 17, 18, 19, 20	

<sup>1)</sup> For further reference please refer to the Operating characteristics table at the end of the Technical data chapter

**Table 38. Three-phase undervoltage protection (27)**

Characteristic		Value		
Pickup accuracy		Depending on the frequency of the voltage measured: $f_n \pm 2\text{Hz}$ $\pm 1.5\%$ of the set value or $\pm 0.002 \times U_n$		
Pickup time <sup>1)2)</sup>	$U_{\text{Fault}} = 0.9 \times \text{set Pickup range}$	Minimum	Typical	Maximum
		62 ms	64 ms	66 ms
Reset time		< 40 ms		
Reset ratio		Depends on the set Relative hysteresis		
Retardation time		< 35 ms		
Trip time accuracy in definite time mode		$\pm 1.0\%$ of the set value or $\pm 20$ ms		
Trip time accuracy in inverse time mode		$\pm 5.0\%$ of the theoretical value or $\pm 20$ ms <sup>3)</sup>		
Suppression of harmonics		DFT: -50dB at $f = n \times f_n$ , where $n = 2, 3, 4, 5, \dots$		

<sup>1)</sup> Pickup range =  $1.0 \times U_n$ , Voltage before fault  $1.1 \times U_n$ ,  $f_n = 50$  Hz, undervoltage in one phase-to-phase with nominal frequency injected from random phase angle, results based on statistical distribution of 1000 measurements

<sup>2)</sup> Includes the delay of the signal output contact

<sup>3)</sup> Minimum Pickup range = 0.50, Pickup range multiples in range of 0.90 to 0.20

**Table 39. Three-phase undervoltage protection (27) main settings**

Parameter	Function	Value (Range)	Step
Pickup range	27	$0.05 \dots 1.20 \times U_n$	0.01
Time multiplier	27	0.05...15.00	0.05
Definite time delay	27	60...300000 ms	10
Operating curve type <sup>1)</sup>	27	Definite or inverse time Curve type: 5, 15, 21, 22, 23	

<sup>1)</sup> For further reference please refer to the Operating characteristics table at the end of the Technical data chapter

**Table 40. Positive sequence undervoltage protection (27PS)**

Characteristic		Value		
Pickup accuracy		Depending on the frequency of the voltage measured: $f_n \pm 2\text{Hz}$ $\pm 1.5\%$ of the set value or $\pm 0.002 \times U_n$		
Pickup time <sup>1)2)</sup>	$U_{\text{Fault}} = 0.99 \times \text{set Pickup range}$	Minimum	Typical	Maximum
		51 ms	53 ms	54 ms
	$U_{\text{Fault}} = 0.9 \times \text{set Pickup range}$	43 ms	45 ms	46 ms
Reset time		< 40 ms		
Reset ratio		Depends on the set Relative hysteresis		
Retardation time		< 35 ms		
Trip time accuracy in definite time mode		$\pm 1.0\%$ of the set value or $\pm 20$ ms		
Suppression of harmonics		DFT: -50dB at $f = n \times f_n$ , where $n = 2, 3, 4, 5, \dots$		

<sup>1)</sup> Pickup range =  $1.0 \times U_n$ , Positive sequence voltage before fault  $1.1 \times U_n$ ,  $f_n = 50$  Hz, positive sequence undervoltage with nominal frequency injected from random phase angle, results based on statistical distribution of 1000 measurements

<sup>2)</sup> Includes the delay of the signal output contact



**Table 41. Positive sequence undervoltage protection (27PS) main settings**

Parameter	Function	Value (Range)	Step
Pickup range	27PS	0.010...1.200 x $U_n$	0.001
Definite time delay	27PS	40...120000 ms	10
Voltage block value	27PS	0.01...1.0 x $U_n$	0.01

**Table 42. Negative sequence overvoltage protection (47)**

Characteristic	Value			
Pickup accuracy	Depending on the frequency of the voltage measured: $f_n \pm 2\text{Hz}$ $\pm 1.5\%$ of the set value or $\pm 0.002 \times U_n$			
Pickup time <sup>1)2)</sup>		Minimum	Typical	Maximum
	$U_{\text{Fault}} = 1.1 \times \text{set Pickup range}$	33 ms	35 ms	37 ms
	$U_{\text{Fault}} = 2.0 \times \text{set Pickup range}$	24 ms	26 ms	28 ms
Reset time	< 40 ms			
Reset ratio	Typical 0.96			
Retardation time	< 35 ms			
Trip time accuracy in definite time mode	$\pm 1.0\%$ of the set value or $\pm 20$ ms			
Suppression of harmonics	DFT: -50dB at $f = n \times f_n$ , where $n = 2, 3, 4, 5, \dots$			

<sup>1)</sup> Negative sequence voltage before fault  $0.0 \times U_n$ ,  $f_n = 50$  Hz, negative sequence overvoltage with nominal frequency injected from random phase angle, results based on statistical distribution of 1000 measurements

<sup>2)</sup> Includes the delay of the signal output contact

**Table 43. Negative sequence overvoltage protection (47) main settings**

Parameter	Function	Value (Range)	Step
Pickup range	47	0.010...1.000 x $U_n$	0.001
Definite time delay	47	40...120000 ms	1

**Table 44. Ground overvoltage protection (59G)**

Characteristic		Value		
Pickup accuracy		Depending on the frequency of the voltage measured: $f_n \pm 2\text{Hz}$ $\pm 1.5\%$ of the set value or $\pm 0.002 \times U_n$		
Pickup time <sup>1) 2)</sup>		Minimum	Typical	Maximum
	$U_{\text{Fault}} = 1.1 \times \text{set Pickup range}$	29 ms	31 ms	32 ms
Reset time		< 40 ms		
Reset ratio		Typical 0.96		
Retardation time		< 35 ms		
Trip time accuracy in definite time mode		$\pm 1.0\%$ of the set value or $\pm 20$ ms		
Suppression of harmonics		DFT: -50dB at $f = n \times f_n$ , where $n = 2, 3, 4, 5, \dots$		

<sup>1)</sup> Residual voltage before fault  $0.0 \times U_n$ ,  $f_n = 50$  Hz, residual voltage with nominal frequency injected from random phase angle, results based on statistical distribution of 1000 measurements

<sup>2)</sup> Includes the delay of the signal output contact

**Table 45. Ground overvoltage protection (59G) main settings**

Parameter	Function	Value (Range)	Step
Pickup range	59G	$0.010 \dots 1.000 \times U_n$	0.001
Definite time delay	59G	40...300000 ms	1

**Table 46. Negative phase-sequence current protection (46)**

Characteristic		Value		
Pickup Accuracy		Depending on the frequency of the current measured: $f_n = \pm 2\text{Hz}$ $\pm 1.5\%$ of the set value or $\pm 0.002 \times I_n$		
Pickup time <sup>1) 2)</sup>		Minimum	Typical	Maximum
	$I_{\text{Fault}} = 2 \times \text{set Pickup range}$	22 ms	24 ms	25 ms
	$I_{\text{Fault}} = 10 \times \text{set Pickup range}$	14 ms	16 ms	17 ms
Reset time		< 40 ms		
Reset ratio		Typical 0.96		
Retardation time		< 35 ms		
Trip time accuracy in definite time mode		$\pm 1.0\%$ of the set value or $\pm 20$ ms		
Trip time accuracy in inverse time mode		$\pm 5.0\%$ of the theoretical value or $\pm 20$ ms <sup>3)</sup>		
Suppression of harmonics		DFT: -50dB at $f = n \times f_n$ , where $n = 2, 3, 4, 5, \dots$		

<sup>1)</sup> Negative sequence current before fault = 0.0,  $f_n = 50$  Hz, results based on statistical distribution of 1000 measurements

<sup>2)</sup> Includes the delay of the signal output contact

<sup>3)</sup> Maximum Pickup range =  $2.5 \times I_n$ , Pickup range multiples in range of 1.5 to 20

**Table 47. Negative phase-sequence current protection (46) main settings**

Parameter	Function	Value (Range)	Step
Pickup range	46	0.01...5.00 x I <sub>n</sub>	0.01
Time multiplier	46	0.05...15.00	0.05
Definite time delay	46	40...200000 ms	10
Operating curve type <sup>1)</sup>	46	Definite or inverse time Curve type: 1, 2, 3, 4, 5, 6, 7, 8, 9, 10, 11, 12, 13, 14, 15, 17, 18, 19	

<sup>1)</sup> For further reference please refer to the Operating characteristics table at the end of the Technical data chapter

**Table 48. Phase discontinuity protection (46PD)**

Characteristic	Value
Pickup Accuracy	Depending on the frequency of the current measured: $f_n \pm 2\text{Hz}$ $\pm 2\%$ of the set value
Pickup time	< 70 ms
Reset time	< 40 ms
Reset ratio	Typical 0.96
Retardation time	< 35 ms
Trip time accuracy in definite time mode	$\pm 1.0\%$ of the set value or $\pm 20$ ms
Suppression of harmonics	DFT: -50dB at $f = n \times f_n$ , where $n = 2, 3, 4, 5, \dots$

**Table 49. Phase discontinuity protection (46PD) main settings**

Parameter	Function	Value (Range)	Step
Pickup range (Current ratio setting I <sub>2</sub> /I <sub>1</sub> )	46PD	10...100 %	1
Definite time delay	46PD	100...30000 ms	1
Min phase current	46PD	0.05...0.30 x I <sub>n</sub>	0.01

**Table 50. Circuit breaker failure protection (50BF/50NBF/50GBF)**

Characteristic	Value
Pickup Accuracy	Depending on the frequency of the current measured: $f_n \pm 2\text{Hz}$ $\pm 1.5\%$ of the set value or $\pm 0.002 \times I_n$
Trip time accuracy	$\pm 1.0\%$ of the set value or $\pm 20$ ms

**Table 51. Circuit breaker failure protection (50BF/50NBF/50GBF) main settings**

Parameter	Function	Value (Range)	Step
Current value (Operating phase current)	50BF/50NBF/50GBF	$0.05 \dots 1.00 \times I_n$	0.05
Current value Res (Operating residual current)	50BF/50NBF/50GBF	$0.05 \dots 1.00 \times I_n$	0.05
CB failure mode (Operating mode of function)	50BF/50NBF/50GBF	1=Current 2=Breaker status 3=Both	
CB fail trip mode	50BF/50NBF/50GBF	1=Off 2=Without check 3=Current check	
Retrip time	50BF/50NBF/50GBF	0...60000 ms	10
CB failure delay	50BF/50NBF/50GBF	0...60000 ms	10
CB fault delay	50BF/50NBF/50GBF	0...60000 ms	10

**Table 52. Three-phase thermal overload (49F)**

Characteristic	Value
Pickup Accuracy	Depending on the frequency of the current measured: $f_n \pm 2\text{Hz}$ Current measurement: $\pm 0.5\%$ or $\pm 0.002 \times I_n$ (at currents in the range of $0.01 \dots 4.00 \times I_n$ )
Trip time accuracy	$\pm 2.0\%$ or $\pm 0.50$ s

**Table 53. Three-phase thermal overload (49F) main settings**

Parameter	Function	Value (Range)	Step
Env temperature Set (Ambient temperature used when the Amb-Sens is set to Off)	49F	$-50 \dots 100^\circ\text{C}$	1
Current multiplier (Current multiplier when function is used for parallel lines)	49F	1...5	1
Current reference	49F	$0.05 \dots 4.00 \times I_n$	0.01
Temperature rise (End temperature rise above ambient)	49F	$0.0 \dots 200.0^\circ\text{C}$	0.1
Time constant (Time constant of the line in seconds)	49F	60...60000 s	1
Maximum temperature (temperature level for trip)	49F	$20.0 \dots 200.0^\circ\text{C}$	0.1

**Table 53. Three-phase thermal overload (49F) main settings (continued)**

Parameter	Function	Value (Range)	Step
Alarm value (Temperature level for start (alarm))	49F	20.0...150.0°C	0.1
Reclose temperature (Temperature for reset of block reclose after trip)	49F	20.0...150.0°C	0.1
Initial temperature (Temperature raise above ambient temperature at startup)	49F	-50.0...100.0 °C	0.1

**Table 54. Three-phase inrush current detection (INR)**

Characteristic	Value
Pickup Accuracy	At the frequency $f=f_n$ Current measurement: $\pm 1.5\%$ of set value or $\pm 0.002 \times I_n$ Ratio I2f/I1f measurement: $\pm 5.0\%$ of set value
Reset time	+35 ms / -0 ms
Reset ratio	Typical 0.96
Trip time accuracy	+35 ms / -0 ms

**Table 55. Three-phase inrush current detection (INR) main settings**

Parameter	Function	Value (Range)	Step
Pickup range (Ratio of the 2nd to the 1st harmonic leading to restraint)	INR	5...100 %	1
Definite time delay	INR	20...60000 ms	1

**Table 56. Arc protection (AFD)**

Characteristic	Value			
Pickup Accuracy	$\pm 3\%$ of the set value or $\pm 0.01 \times I_n$			
Trip time	Minimum	Typical	Maximum	
	Operation mode = "Light+current" <sup>1) 2)</sup>	9 ms	12 ms	15 ms
	Operation mode = "Light only" <sup>2)</sup>	9 ms	10 ms	12 ms
Reset time	< 40 ms			
Reset ratio	Typical 0.96			

<sup>1)</sup> Phase Pickup range =  $1.0 \times I_n$ , current before fault =  $2.0 \times$  set Phase Pickup range,  $f_n = 50\text{Hz}$ , fault with nominal frequency, results based on statistical distribution 200 measurements

<sup>2)</sup> Includes the delay of the heavy-duty output contact

**Table 57. Arc protection (AFD) main settings**

Parameter	Function	Value (Range)	Step
Phase Pickup range (Operating phase current)	AFD	0.50...40.00 x I <sub>n</sub>	0.01
Ground Pickup range (Operating residual current)	AFD	0.05...8.00 x I <sub>n</sub>	0.01
Operation mode	AFD	1=Light+current 2=Light only 3=BI controlled	

**Table 58. Operating characteristics**

Parameter	Values (Range)
Inverse-time and definite-time curve types (overcurrent protection)	1=ANSI Ext. inv. 2=ANSI Very. inv. 3=ANSI Norm. inv. 4=ANSI Mod inv. 5=ANSI Def. Time 6=L.T.E. inv. 7=L.T.V. inv. 8=L.T. inv. 9=IEC Norm. inv. 10=IEC Very inv. 11=IEC inv. 12=IEC Ext. inv. 13=IEC S.T. inv. 14=IEC L.T. inv 15=IEC Def. Time 17=Programmable 18=RI type 19=RD type
Inverse-time and definite-time curve types (voltage protection)	5=ANSI Def. Time 15=IEC Def. Time 17=Inv. Curve A 18=Inv. Curve B 19=Inv. Curve C 20=Programmable 21=Inv. Curve A 22=Inv. Curve B 23=Programmable

**Table 59. Non-directional sensitive earth fault protection (50SEF)**

Characteristic		Value		
Pickup accuracy		Depending on the frequency of the current measured: $f_n \pm 2\text{Hz}$		
	50SEF	$\pm 1.5\%$ of set value or $\pm 0.002 \times I_n$ (at currents in the range of $0.1 \dots 10 \times I_n$ ) $\pm 5.0\%$ of the set value (at currents in the range of $10 \dots 40 \times I_n$ )		
Pickup time <sup>1)2)</sup>		Minimum	Typical	Maximum
	50SEF:			
	$I_{\text{Fault}} = 2 \times \text{set Pickup value}$ $I_{\text{Fault}} = 10 \times \text{set Pickup value}$	16 ms 11 ms	19 ms 12 ms	23 ms 14 ms
Instantaneous trip time <sup>1)3)</sup>		Minimum	Typical	Maximum
	550SEF:			
	$I_{\text{Fault}} = 2 \times \text{set Pickup value}$ $I_{\text{Fault}} = 10 \times \text{set Pickup value}$	19 ms 14 ms	23 ms 16 ms	27 ms 17 ms
Reset time		< 40 ms		
Reset ratio		Typical 0.96		
Retardation time		< 30 ms		
Trip time accuracy in definite time mode		$\pm 1.0\%$ of the set value or $\pm 20$ ms		
Trip time accuracy in inverse time mode		$\pm 5.0\%$ of the theoretical value or $\pm 20$ ms <sup>4)</sup>		
Suppression of harmonics		RMS: No suppression DFT: -50dB at $f = n \times f_n$ , where $n = 2, 3, 4, 5, \dots$ Peak-to-Peak: No suppression		

**Table 60. Non-directional sensitive earth fault protection (50SEF) main settings**

Parameter	Function	Value (Range)	Step
Pickup range	50SEF	$0.10 \dots 40.00 \times I_n$	0.01
Definite time delay	50SEF	$0.020 \dots 200.00$ s	0.001

**Table 61. Restricted earth fault, low impedance (REF)**

Characteristic		Value		
Pickup accuracy		Depending on the frequency of the voltage measured: $f_n \pm 2\text{Hz}$		
		$\pm 2.5\%$ of the set value or $\pm 0.002 \times I_n$		
Pickup time <sup>1)2)</sup>		Minimum	Typical	Maximum
	$I_{\text{Fault}} = 2.0 \times \text{set Trip value}$	38 ms	40ms	43 ms
Reset time		< 40 ms		
Reset ratio		Typical 0.96		
Retardation time		< 35 ms		
Trip time accuracy in definite time mode		$\pm 1.0\%$ of the set value or $\pm 20$ ms		
Suppression of harmonics		DFT: -50dB at $f = n \times f_n$ , where $n = 2, 3, 4, 5, \dots$		

<sup>1)</sup> Pickup range =  $1.0 \times U_n$ , Voltage before fault  $0.9 \times U_n$ ,  $f_n = 50$  Hz, overvoltage in one phase-to-phase with nominal frequency injected from random phase angle, results based on statistical distribution of 1000 measurements

<sup>2)</sup> Includes the delay of the signal output contact

<sup>3)</sup> Maximum Pickup range =  $1.20 \times U_n$ , Pickup range multiples in range of 1.10 to 2.00

**Table 62. Restricted earth fault, low impedance (REF) main settings**

Parameter	Function	Value (Range)	Step
Trip value	LREFPNDF	5...50 %	1
Restraint mode	LREFPNDF	None 2nd harmonic	-
Pickup range 2.H	LREFPNDF	10...50 %	1
Minimum trip time	LREFPNDF	40...300000 ms	1
Operation	LREFPNDF	Off On	

**Table 63. Three-phase undercurrent protection (37)**

Characteristic	Value
Pickup Accuracy	Depending on the frequency of the current measured: $f_n \pm 2\text{Hz}$ $\pm 1.5\%$ of the set value or $\pm 0.002 \times I_n$
Pickup time	Typical 300 ms
Reset time	< 40 ms
Reset ratio	Typical 0.96
Retardation time	< 35 ms
Trip time accuracy in definite time mode	$\pm 1.0\%$ of the set value or $\pm 20$ ms

**Table 64. Three-phase undercurrent protection (37) main settings**

Parameter	Function	Value (Range)	Step
Pickup range high	37	0.01...1.00 x $I_n$	0.01
Pickup range low	37	0.01...0.50 x $I_n$	0.01
Definite time delay	37	400...600000 ms	10
Operation	37	Off On	

## Control functions

**Table 65. Autoreclose (79)**

Characteristic	Value
Reclose accuracy	$\pm 1.0\%$ of the set value or $\pm 20$ ms

**Table 66. Autoreclose (79) main settings**

Parameter	Function	Value (Range)	Step
Reset time	79	0.10...1800.000 s	0.001
Reclose attempts	79	0...7	1
Reclose time	79	0.000...300.00 s	0.001
Enable/disable protection	79	Programmable per reclose attempt	



## Measurement functions

**Table 67. Three-phase current measurements (IA, IB, IC)**

Characteristic	Value
Pickup accuracy	Depending on the frequency of the current measured: $f_n \pm 2\text{Hz}$
	$\pm 0.5\%$ or $\pm 0.002 \times I_n$ (at currents in the range of $0.01 \dots 4.00 \times I_n$ )
Suppression of harmonics	DFT: $-50\text{dB}$ at $f = n \times f_n$ , where $n = 2, 3, 4, 5, \dots$ RMS: No suppression

**Table 68. Current sequence components (I1, I2, I0)**

Characteristic	Value
Pickup accuracy	Depending on the frequency of the current measured: $f/f_n = \pm 2\text{Hz}$
	$\pm 1.0\%$ or $\pm 0.002 \times I_n$ at currents in the range of $0.01 \dots 4.00 \times I_n$
Suppression of harmonics	DFT: $-50\text{dB}$ at $f = n \times f_n$ , where $n = 2, 3, 4, 5, \dots$

**Table 69. Three-phase voltage measurements (VA, VB, VC)**

Characteristic	Value
Pickup accuracy	Depending on the frequency of the voltage measured: $f_n \pm 2\text{Hz}$ (at voltages in range $0.01 \dots 1.15 \times U_n$ )
	$\pm 0.5\%$ or $\pm 0.002 \times U_n$
Suppression of harmonics	DFT: $-50\text{dB}$ at $f = n \times f_n$ , where $n = 2, 3, 4, 5, \dots$ RMS: No suppression

**Table 70. Voltage sequence components (V1, V2, V0)**

Characteristic	Value
Pickup accuracy	Depending on the frequency of the voltage measured: $f_n \pm 2\text{Hz}$ at voltages in the range of $0.01 \dots 1.15 \times U_n$
	$\pm 1.0\%$ or $\pm 0.002 \times U_n$
Suppression of harmonics	DFT: $-50\text{dB}$ at $f = n \times f_n$ , where $n = 2, 3, 4, 5, \dots$

**Table 71. Ground current measurement (IG)**

Characteristic	Value
Pickup accuracy	Depending on the frequency of the current measured: $f/f_n = \pm 2\text{Hz}$
	$\pm 0.5\%$ or $\pm 0.002 \times I_n$ at currents in the range of $0.01 \dots 4.00 \times I_n$
Suppression of harmonics	DFT: $-50\text{dB}$ at $f = n \times f_n$ , where $n = 2, 3, 4, 5, \dots$ RMS: No suppression

**Table 72. Ground voltage measurement (VG)**

Characteristic	Value
Pickup accuracy	Depending on the frequency of the current measured: $f/f_n = \pm 2\text{Hz}$
	$\pm 0.5\%$ or $\pm 0.002 \times U_n$
Suppression of harmonics	DFT: $-50\text{dB}$ at $f = n \times f_n$ , where $n = 2, 3, 4, 5, \dots$ RMS: No suppression

**Table 73. Three-phase power and energy (P, E)**

Characteristic	Value
Pickup accuracy	At all three currents in range $0.10...1.20 \times I_n$ At all three voltages in range $0.50...1.15 \times U_n$ At the frequency $f_n \pm 1\text{Hz}$ Active power and energy in range $ \text{PF}  > 0.71$ Reactive power and energy in range $ \text{PF}  < 0.71$
	$\pm 1.5\%$ for power (S,P and Q) $\pm 0.015$ for power factor $\pm 1.5\%$ for energy
Suppression of harmonics	DFT: $-50\text{dB}$ at $f = n \times f_n$ , where $n = 2, 3, 4, 5, \dots$

## Supervision functions

**Table 74. Current circuit supervision (CCM)**

Characteristic	Value
Trip time <sup>1)</sup>	$< 30 \text{ ms}$

<sup>1)</sup> Including the delay of the output contact

**Table 75. Current circuit supervision (CCM) main settings**

Parameter	Values (Range)	Unit	Description
Pickup range	0.05...0.20	$\times I_n$	Minimum trip current differential level
Maximum trip current	1.00...5.00	$\times I_n$	Block of the function at high phase current

**Table 76. Fuse failure supervision (60)**

Characteristic	Value	
Trip time <sup>1)</sup>	NPS function:	
	$U_{\text{Fault}} = 1.1 \times \text{set Neg Seq voltage Lev}$	$< 33 \text{ ms}$
	$U_{\text{Fault}} = 5.0 \times \text{set Neg Seq voltage Lev}$	$< 18 \text{ ms}$
	Delta function:	
	$\Delta U = 1.1 \times \text{set Voltage change rate}$	$< 30 \text{ ms}$
	$\Delta U = 2.0 \times \text{set Voltage change rate}$	$< 24 \text{ ms}$

<sup>1)</sup> Includes the delay of the signal output contact,  $f_n = 50 \text{ Hz}$ , fault voltage with nominal frequency injected from random phase angle, results based on statistical distribution of 1000 measurements

## 20. Display

The relay's local HMI includes a large LCD screen standard. The large LCD display offers full front-panel user-interface functionality with menu navigation and menu views.

The large display offers increased front-panel usability with less menu scrolling and improved information overview than with smaller LCD screens. The large

display is well-suited for all relay installations providing an easy viewing interface.



Fig. 12: Large display standard

Table 77. Large display

Character size	Rows in the view	Characters per row
Large, variable width (13x14pixels)	10	20 or more

## 21. Mounting methods

By means of appropriate mounting accessories the standard relay case for the 615 series relays can be flush mounted, semi-flush mounted or wall mounted. The flush mounted and wall mounted relay cases can also be mounted in a tilted position (25°) using special accessories.

Further, the relays can be mounted in any standard 19" instrument cabinet by means of 19" mounting panels available with cut-outs for one or two relays.

For the routine testing purposes, the relay cases can be equipped with Flexitest (FT) test switches, type FT-1 or FT-19R, which can be mounted side by side or below the relay cases.

Mounting methods:

- Flush mounting
- Semi-flush mounting
- Semi-flush mounting in a 25° tilt
- Rack mounting
- Wall mounting
- Mounting to a 19" equipment frame
- Mounting with Flexitest (FT) test switches to a 19" rack

Panel cut-out for flush mounting:

- Height: 6.36" ± 0.04" (161.5 ± 1 mm)
- Width: 6.52" ± 0.04" (165.5 ± 1 mm)

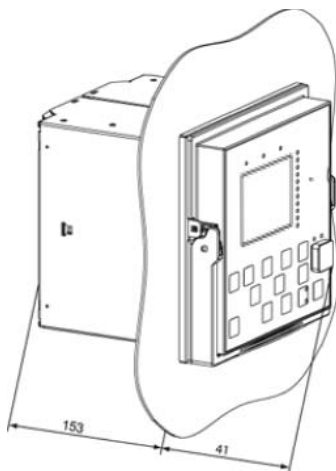

Figure 13: Flush mounting

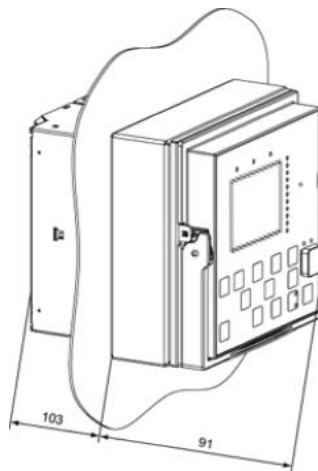

Figure 14: Semi-flush mounting

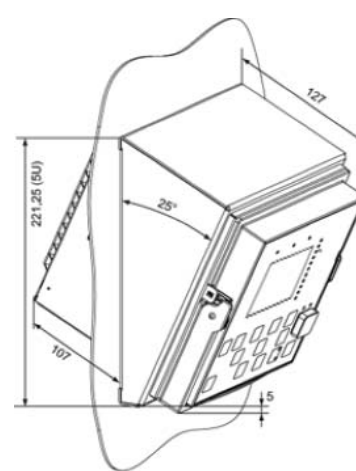

Figure 15: Semi-flush with a 25° tilt

## 22. Relay case and drawout unit

For safety reasons, the relay cases are provided with automatically operating contacts for short-circuiting the CT secondary circuits when a relay unit is withdrawn from its case. The relay case is further provided with a mechanical coding system preventing current measuring relay units from being inserted into a relay case for a voltage measuring relay unit and vice versa, i.e. the relay cases are assigned to a certain type of relay draw-out unit.

## 23. Selection and ordering data

Use the ordering key information in Fig. 10 to generate the order number when ordering complete protection relays.

The relay type and serial number label identifies the protection relay. The label is placed above the HMI on the upper part of the draw-out unit. An order number label is placed on the side of the draw-out unit as well as inside the case. The order number consists of a string of alphanumeric characters generated from the hardware and software modules of the relay.

REF615 Ordering Code																					
Code Character	Description	1	2	3	4	5	6	7	8	9	10	11	12	13	14	15	16	17	18	Notes	
	Ex.: HAFDDBANBE1BAN1XC	H	A	F	D	D	B	D	A	N	B	E	1	B	A	N	1	X	C		
1) Product Series	H: 615 (Draw-out unit with case)	H																			
2) Standard	A: ANSI		A																		
3) Main Application	F: Feeder protection and control			F																	
4) Functional Application	A: Single breaker (CT Inputs only)					A															
	D: Single breaker, loop (CT & VT inputs)					D															
5-6) Analog Inputs	A: 3 CT					A	A														
	A: 3 CT + Ground CT					A	B														
	A: 3 CT + SEF/HIZ CT					A	A														
	D: 3 CT + Ground CT + 5 VT					D	A														
7-8) Binary I/O	A: 4 BI + 6 BO							A	A												
	A: 12 BI + 10 BO							A	B												
	A: 18 BI + 13 BO							A	C												
	D: 16 BI + 10 BO							D	A												
9-11) Communications	One Port: Ethernet 100Base FX (LC)									N	A	E									
	One Port: Ethernet 100Base TX (RJ45)									N	B	E									
	Two/three ports: [Ethernet 100Base FX (LC) + RS-485 (1x4-wire or 2x2-wire)] + IRIG-B									A	A	E									
	Two/three ports: [Ethernet 100Base TX (RJ45) + RS-485 (1x4-wire or 2x2-wire)] + IRIG-B									A	B	E									
	Three ports: Ethernet 10/100BaseT (RJ45) + configurable RS232/RS485 + [RS485 or serial glass fiber (ST)]									3	3	E									
Includes Arc Flash Detection (AFD)	One Port: Ethernet 100Base FX (LC)									N	F	E								1	
	One Port: Ethernet 100Base TX (RJ45)									N	G	E								1	
	Two/three ports: [Ethernet 100Base FX (LC) + RS-485 (1x4-wire or 2x2-wire)] + IRIG-B									F	F	E								1	
	Two/three ports: [Ethernet 100Base TX (RJ45) + RS-485 (1x4-wire or 2x2-wire)] + IRIG-B									F	G	E								1	
12) Language	English																			1	
13) Front Panel	Large LCD (standard)														B						
14) Option 1	Reclosing																			A	
	None																			N	
15) Option 2	None																			N	
16) Power Supply	48-250 Vdc; 48-240 Vac																			1	
	24-60 Vdc																			2	
17) Reserved	Reserved																			X	
18) Version	Version 2.0																				C

Note 1: When the Arc Flash Detection option is selected then fiber lens must be quoted and ordered separately.

Example code: **HAFDDADAFBE1BAN1XC**

Your ordering code:

Digit (#)      1   2   3   4   5   6   7   8   9   10   11   12   13   14   15   16   17   18

Code

## 24. Accessories and ordering data

Table 78. Accessories and ordering data.

Item	Order Number
<b>Tools</b>	
PCM600 V2.0 user tool	PCM600-20
<b>Cables</b>	
Cable for optical sensors for arc protection 1.5 m	1MRS120534-1.5
Cable for optical sensors for arc protection 3.0 m	1MRS120534-3.0
Cable for optical sensors for arc protection 5.0 m	1MRS120534-5.0
<b>Mounting accessories</b>	
Semi-flush mounting kit	1MRS050696
Wall mounting kit	1MRS050697
Inclined semi-flush mounting kit	1MRS050831
19" rack mounting kit with cutout for one relay, ANSI 61	604539-K1
19" rack mounting kit with cutout for one relay, ANSI 70	604539-K3
19" rack mounting kit with cutout for two relays, ANSI 61	604540-K1
19" rack mounting kit with cutout for two relays, ANSI 70	604540-K3
<b>Retrofit adapter plates</b>	
DPU/DPU2000 Horizontal - ANSI 61 (medium gray)	604529-K1
DPU/DPU2000 Horizontal - ANSI 70 (light gray)	604529-K3
DPU/DPU2000 Vertical - ANSI 61 medium gray)	604529-K2
DPU/DPU2000 Vertical - ANSI 70 (light gray)	604529-K4
IMPRS - ANSI 61 (medium gray)	604534-K1
IMPRS - ANSI 70 (light gray)	604534-K3
<b>Test switches</b>	
FT-1, FT-14, and FT-19 Flexitest switches	See Descriptive bulletins DB 41-077 and DB 41-078 on <a href="http://www.abb.com/substationautomation">www.abb.com/substationautomation</a>

## 25. Tools

The relay is delivered as a pre-configured unit. The default parameter setting values can be changed from the front-panel user interface, the web-browser based user interface (WHMI) or the PCM600 tool in combination with the relay specific connectivity package (CP).

PCM600 offers extensive relay configuration functions such as relay signal configuration using the signal matrix tool, and IEC 61850 communication configuration including horizontal relay-to-relay communication,

GOOSE.

When the web-browser based user interface is used, the relay can be accessed either locally or remotely using a web browser (IE 6.0 or later). For security reasons, the web-browser based user interface is disabled by default. The interface can be enabled with the PCM600 tool or from the front panel user interface. The functionality of the interface can be limited to read-only access by means of PCM600.

**Table 79. Tools**

Configuration, setting and SA system tools	Version
PCM600	2.1 or later
Web-browser based user interface	IE 7.0 or later
REF615 Connectivity Package	2.0 or later
COM600 substation product	V3.4 or later
MicroSCADA Pro Substation Automation system	9.2 SP1 or later

**Table 80. Supported functions**

Function	WebHMI	PCM600
Relay signal configuration (signal matrix tool)	-	•
IEC 61850 communication configuration, GOOSE (communication configuration tool)	-	•
Modbus <sup>1)</sup> communication configuration (communication management tool)	-	- <sup>1)</sup>
DNP3.0 Level 2+ communication configuration (communication management tool)	-	•
IEC 60870-5-103 communication configuration (communication management tool)	-	•
Relay parameter setting	•	•
Saving of relay parameter settings in the relay	•	•
Saving of relay parameter settings in the tool	-	•
Signal monitoring	•	•
Digital fault recorder (DFR) handling	•	•
Digital fault record analysis	-	•
Event viewing	•	-
Saving of event data on the user's PC	•	-
Alarm LED viewing	•	•
Phasor diagram viewing	•	-
Access control management	•	•

• = Supported

<sup>1)</sup> Analog and digital values pre-mapped to registers for easy individual or grouped register retrieval by Modbus driver

## 26. Terminal diagrams

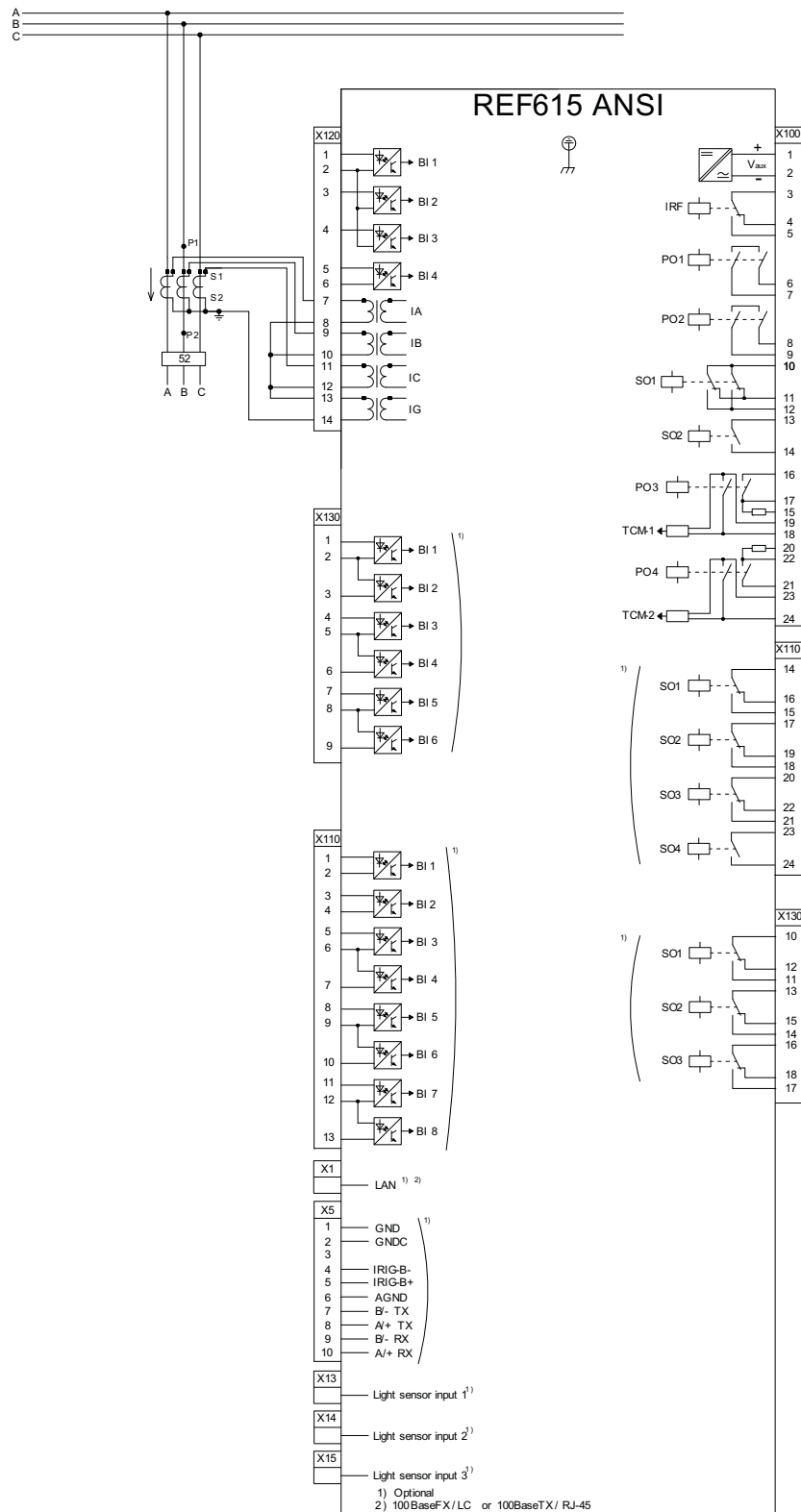

Figure 16. REF615 standard configuration A with options



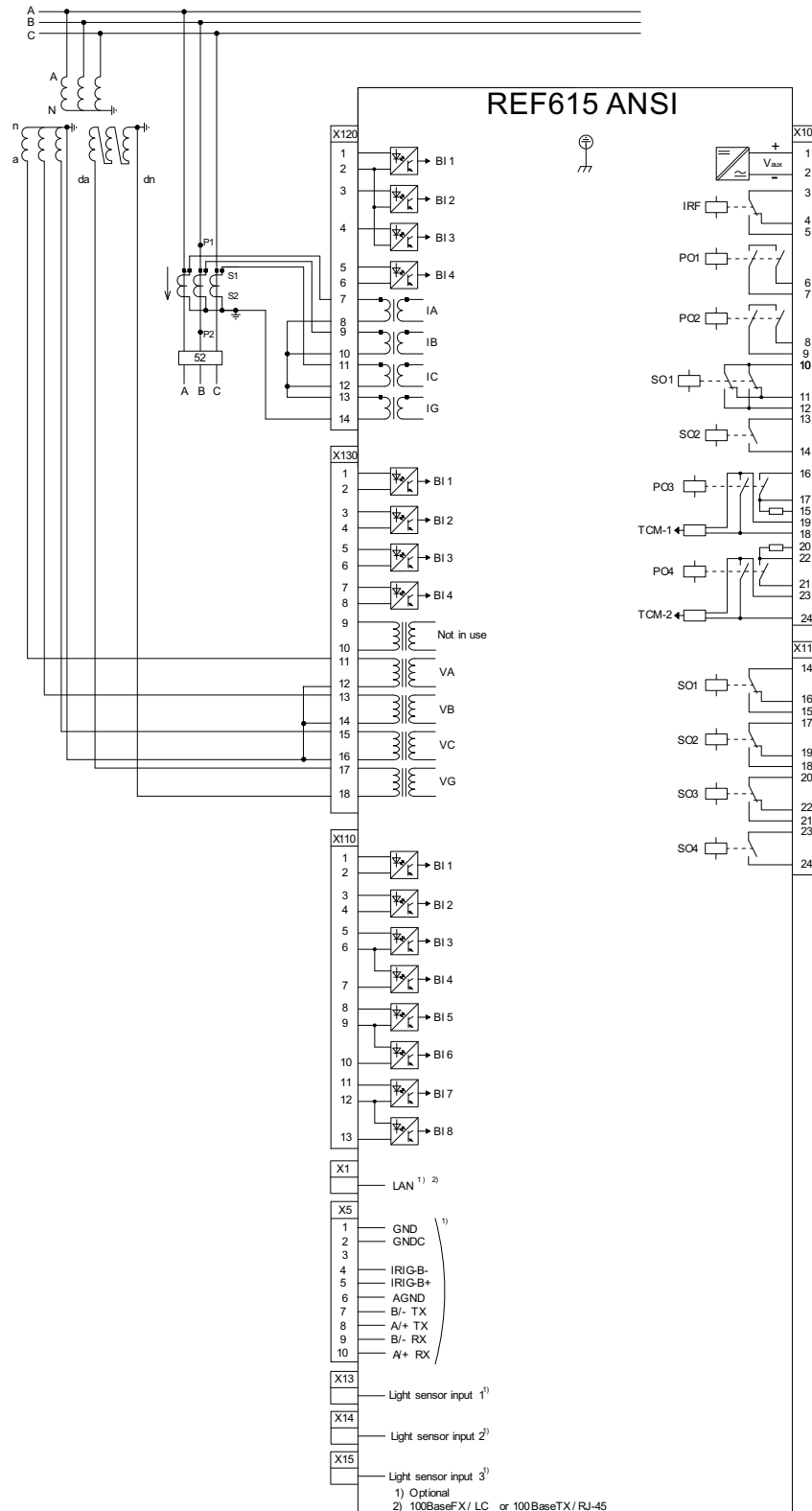

Figure 17. REF615 standard configuration D with options

## 27. Certificates

KEMA has issued an IEC 61850 Certificate Level A1 for REF615. Certificate number: 30710144-Consulting 08-0115

The REF615 is a UL Listed product, UL File/Sec. E103204/2/2.” with “The REF615 is a UL Listed product per UL File E103204 for these power supply order codes - see Section 23 for Ordering data details.

UL Listed Control Voltage/ Power Input, V:	REF615 “Power Supply” order code’s 16th character	Operating temperature (ambient) range
24-60 Vdc nominal	2	-25°C to +55°C
80-250 Vdc (80-240 Vac) nominal	1	-25°C to +55°C

## 28. References

The download area on the right hand side of the web page contains the latest product documentation, such as technical reference manual, installation manual, operators manual,etc. The selection tool on the web page helps you find the documents by the document category and language.

The Features and Application tabs contain product related information in a compact format.

The www.abb.com/substationautomation portal offers you information about the distribution automation product and service range.

You will find the latest relevant information on the REF615 protection relay on the product page.

The screenshot shows the ABB website interface for the REF615 ANSI product page. At the top left is the ABB logo with the tagline 'Power and productivity for a better world™'. The top right contains links for 'Sitemap', 'Login', and accessibility icons. A navigation menu below the logo includes 'Home', 'About ABB', 'Products & services', 'News center', 'Careers', and 'Investor relations'. A secondary menu lists 'Offerings A-Z', 'ABB Product Guide', 'Industries and utilities', 'Service Guide', and 'Contact Directory'. The breadcrumb trail reads: 'Product Guide > Power Protection & Automation Products > Protection and Control (Distribution) > Feeder Protection and Control > REF615 ANSI'. The main heading is 'Feeder Protection Relay REF615 ANSI', with sub-tabs for 'Overview', 'Tools', 'Service & Support', 'Product Registration', and 'Contacts'. The 'Overview' tab is active, displaying descriptive text about the relay's function and IEC 61850 implementation. To the right, the 'Documentation and downloads' section lists various documents: a brochure (0.42 MB), an installation manual (1.87 MB), an LED label template (0.13 MB), an application manual (3.06 MB), an operation manual (6.41 MB), a technical manual (4.56 MB), a product guide (0.79 MB), and a connectivity package (71.08 MB). A search box and user preference settings (language: English, location: United States of America) are also visible. A small image of the relay device is shown at the bottom right of the documentation section.

Figure 17. Product page

## 29. Functions, codes and symbols

Table 81. REF615 Functions, codes and symbols

Function	IEC 61850	ANSI C37.2-2008
<b>Protection</b>		
Three-phase non-directional time overcurrent	PHLPTOC	51P
Three-phase non-directional instantaneous overcurrent, low-set, instance 1	PHHPPTOC1	50P-1
Three-phase non-directional instantaneous overcurrent, low-set, instance 2	PHHPPTOC2	50P-2
Three-phase non-directional instantaneous overcurrent, high-set	PHIPTOC	50P-3
Three-phase directional time overcurrent	DPHLPDOC1	67/51P
Three-phase directional instantaneous overcurrent, instance 1	DPHLPDOC2	67/50P-1
Three-phase directional instantaneous overcurrent, instance 2	DPHHPDOC	67/50P-2
Neutral, ground non-directional time overcurrent	EFLPTOC	51N, 51G
Neutral, ground non-directional instantaneous overcurrent, low-set, instance 1	EFHPTOC1	50N-1, 50G-1
Neutral, ground non-directional instantaneous overcurrent, low-set, instance 2	EFHPTOC2	50N-2, 50G-2
Neutral, ground non-directional instantaneous overcurrent, high-set	EFIPTOC	50N-3, 50G-3
Neutral, ground directional time overcurrent	DEFLPDEF1	67/51N
Neutral, ground directional instantaneous overcurrent, instance 1	DEFLPDEF2	67/50N-1
Neutral, ground directional instantaneous overcurrent, instance 2	DEFHPDEF	67/50N-2
Negative-sequence overcurrent protection, instance 1	NSPTOC1	46-1
Negative-sequence overcurrent protection, instance 2	NSPTOC2	46-2
Phase discontinuity protection	PDNSPTOC	46PD
Ground overvoltage protection	ROVPTOV	59G
Three-phase undervoltage protection, instance 1	PHPTUV1	27-1
Three-phase undervoltage protection, instance 2	PHPTUV2	27-2
Three-phase overvoltage protection, instance 1	PHPTOV1	59-1
Three-phase overvoltage protection, instance 2	PHPTOV2	59-2
Positive-sequence undervoltage protection	PSPTUV	27PS
Negative-sequence overvoltage protection	NSPTOV	47
Three-phase thermal protection for feeders, cables and distribution transformers	T1PTTR	49F
Circuit breaker failure protection	CCBRBRF	50BF/50NBF

**Table 81. REF615 Functions, codes and symbols (continued)**

<b>Function</b>	<b>IEC 61850</b>	<b>ANSI C37.2-2008</b>
Three-phase inrush detector	INRPHAR1	INR
Master trip, instance 1	TRPPTRC1	94/86-1
Master trip, instance 2	TRPPTRC2	94/86-2
Arc flash detection (AFD), instance 1	ARCSARC1	AFD-1
Arc flash detection (AFD), instance 2	ARCSARC2	AFD-2
Arc flash detection (AFD), instance 3	ARCSARC3	AFD-3
<b>Control</b>		
Circuit-breaker control	CBXCBR1	52
Autoreclose	DARREC1	79
<b>Condition Monitoring</b>		
Circuit-breaker condition monitoring	SSCBR1	52CM
Trip circuit monitoring, instance 1	TCSSCBR1	TCM-1
Trip circuit monitoring, instance 2	TCSSCBR2	TCM-2
Current circuit supervision	CCRDIF1	CCM
Fuse failure supervision	SEQRFUF1	60
<b>Measurement</b>		
Digital fault recorder (DFR)	RDRE1	DFR
Three-phase currents	CMMXU1	IA, IB, IC
Sequence currents	CSMSQI1	$I_1, I_2, I_0$
Ground current	RESCMMXU1	IG
Three-phase voltages	VMMXU1	VA, VB, VC
Ground voltage	RESVMMXU1	VG
Sequence voltages	VSMSQI1	$V_1, V_2, V_0$
Three-phase power, energy and power factor	PEMMXU1	P, E, PF

## 30. Document revision history

**Table 82. Document revision history**

A / March 31, 2008	V1.0	Initial product version release
B / December 31, 2008	V1.1	Content updated to correspond to new product version release
C / March 01, 2010	V2.0	Content updated to correspond to new product version release

---

## 31. Notes

---



# Contact us

**ABB Inc.**

**Distribution Automation**

4300 Coral Ridge Drive  
Coral Springs, Florida 33065  
Phone: +1 954 752 6700  
Fax: +1 954 345 5329

[www.abb.com/substationautomation](http://www.abb.com/substationautomation)

All sales are subject to ABB Inc.  
General Terms and Conditions of Sale.

While every effort has been made to  
assure accuracy, the information in this  
document is subject to change without  
notice.

© Copyright 2008, 2010 ABB Inc. All  
rights reserved.

1MAC105361-PG Rev. C March 2010 (replaces 1VAD386601-AG)