

OPTIONS FOR ABB DRIVES AND CONVERTERS

TTL Encoder Interface FEN-01

User's manual

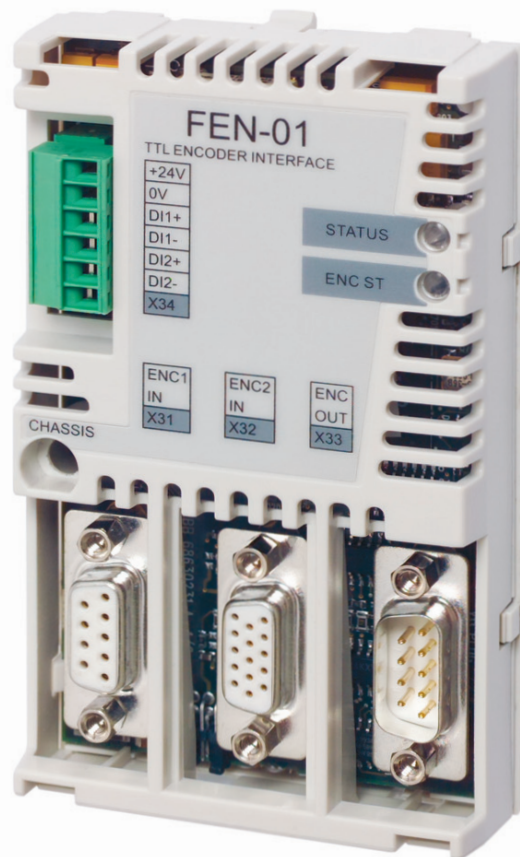

TTL Encoder Interface FEN-01

User's manual

Table of contents



3AFE68784603 Rev E
EN
Original instructions
EFFECTIVE: 2023-07-14

Table of contents

1 Safety instructions

Contents of this chapter	7
Overview	7
General safety instructions	7

2 Introduction

Contents of this chapter	9
Intended audience	9
Before you start	9

3 Hardware description

Contents of this chapter	11
The FEN-01 TTL Encoder Interface	12
FEN-01 connections	13
Isolation areas	14
Compatibility	14

4 Installation

Contents of this chapter	15
Setting the supply voltage	16
Mounting	17
Terminal designations	17
Abbreviations	17
TTL encoder input (X31)	18
TTL encoder input with commutation signal support (X32)	19
TTL encoder emulation output (X33)	20
Digital inputs for position latching (X34)	20
General encoder wiring guidelines	21
TTL encoder input (X31)	22
TTL encoder input with commutation signal support (X32)	23
TTL Emulation output (X33)	25
Digital inputs for position latching (X34)	26
General encoder phasing principle	27

5 Start-up

Contents of this chapter	29
Programming	29

6 Fault tracing

Contents of this chapter	31
Diagnostic LEDs	31

7 Technical data

Contents of this chapter	33
--------------------------------	----



6 Table of contents

Dimensions	34
General	34
Connectors	34
TTL encoder input (X31)	35
TTL encoder input with commutation support (X32)	35
TTL encoder emulation output (X33)	35
Digital inputs for position latch (X34)	36

Further information



1

Safety instructions

Contents of this chapter

The chapter contains the warning symbols and the safety instructions which you must obey when you install or connect an optional module to a drive or converter. If you ignore the safety instructions, injury, death or damage can occur. Read this chapter before you start the installation.

Overview

This chapter states the general safety instructions that must be followed when installing and operating the FEN-01.

In addition to the safety instructions given below, read the complete safety instructions of the specific drive you are working on.

These warnings are intended for all who work on the drive. Ignoring the instructions can cause physical injury or death, or damage the equipment.

General safety instructions

**WARNING!**

All electrical installation and maintenance work on the drive must be carried out by qualified electricians only.

The drive and adjoining equipment must be properly earthed.

Do not attempt any work on a powered drive. After switching off the mains, always allow the intermediate circuit capacitors 5 minutes to discharge before working on the frequency converter, the motor or the motor cable. Check (with a voltage tester) that the drive is in fact discharged before beginning work.

8 Safety instructions

The motor cable terminals of the drive are at a dangerously high voltage when mains power is applied, regardless of motor operation.

There can be dangerous voltages inside the drive from external control circuits even when the drive mains power is shut off.

Exercise appropriate care when working on the unit.

These warnings are intended for all who work on the drive. Ignoring the instructions can cause physical injury or death, or damage the equipment.

For complete safety instructions see the drive manuals.

2

Introduction

Contents of this chapter

This chapter introduces this manual.

Intended audience

The manual is intended for the people who are responsible for commissioning and using the FEN-01. The reader is expected to have a basic knowledge of electrical fundamentals, electrical wiring practices and how to operate the drive.

Before you start

It is assumed that the drive is installed and the drive power supply is switched off before starting the installation of the extension module. Ensure that all dangerous voltages connected from external control circuits to the inputs and outputs of the drive are switched off.

In addition to conventional installation tools, have the drive manuals available during the installation as they contain important information not included in this manual. The drive manuals are referred to at various points of this document.

A large, light gray square with rounded corners, centered on the page. Inside the square, the number '3' is written in a large, bold, black font.

Hardware description

Contents of this chapter

This chapter contains a short description of the FEN-01 TTL Encoder Interface module.

The FEN-01 TTL Encoder Interface

The FEN-01 offers an interface for two TTL encoder connections, one with commutation signals and PTC support. It also offers a TTL encoder output for emulation purposes and two digital latch inputs for position latching.

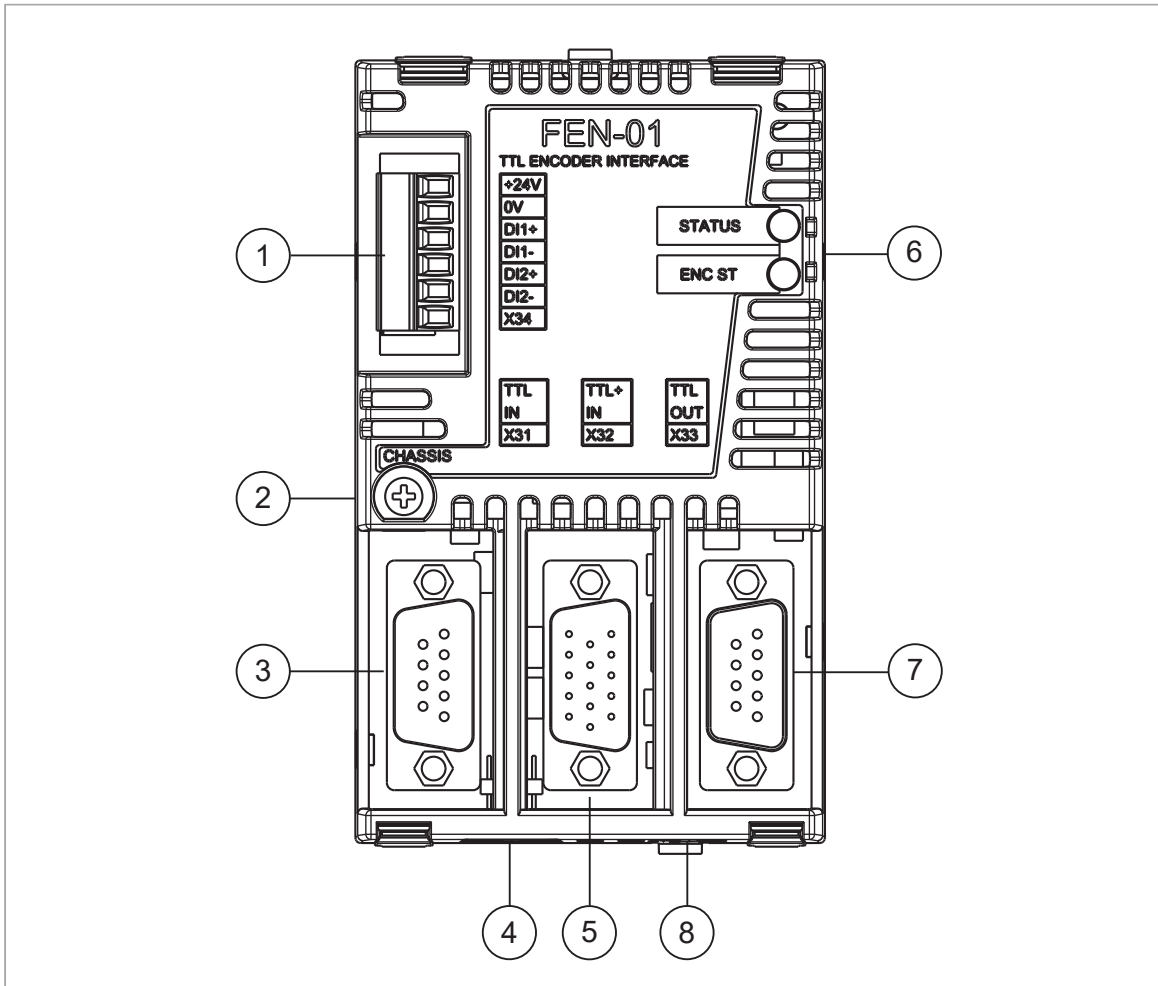

1	2 digital latch inputs (X34)
2	Fixing screw
3	TTL encoder input (X31)
4	Encoder voltage selection jumper (X301)
5	TTL encoder input with commutation and PTC support (X32)
6	Diagnostic LEDs
7	TTL encoder output (X33)
8	Locking tab

■ **FEN-01 connections**

The following figure shows an overview of the connections of the FEN-01.

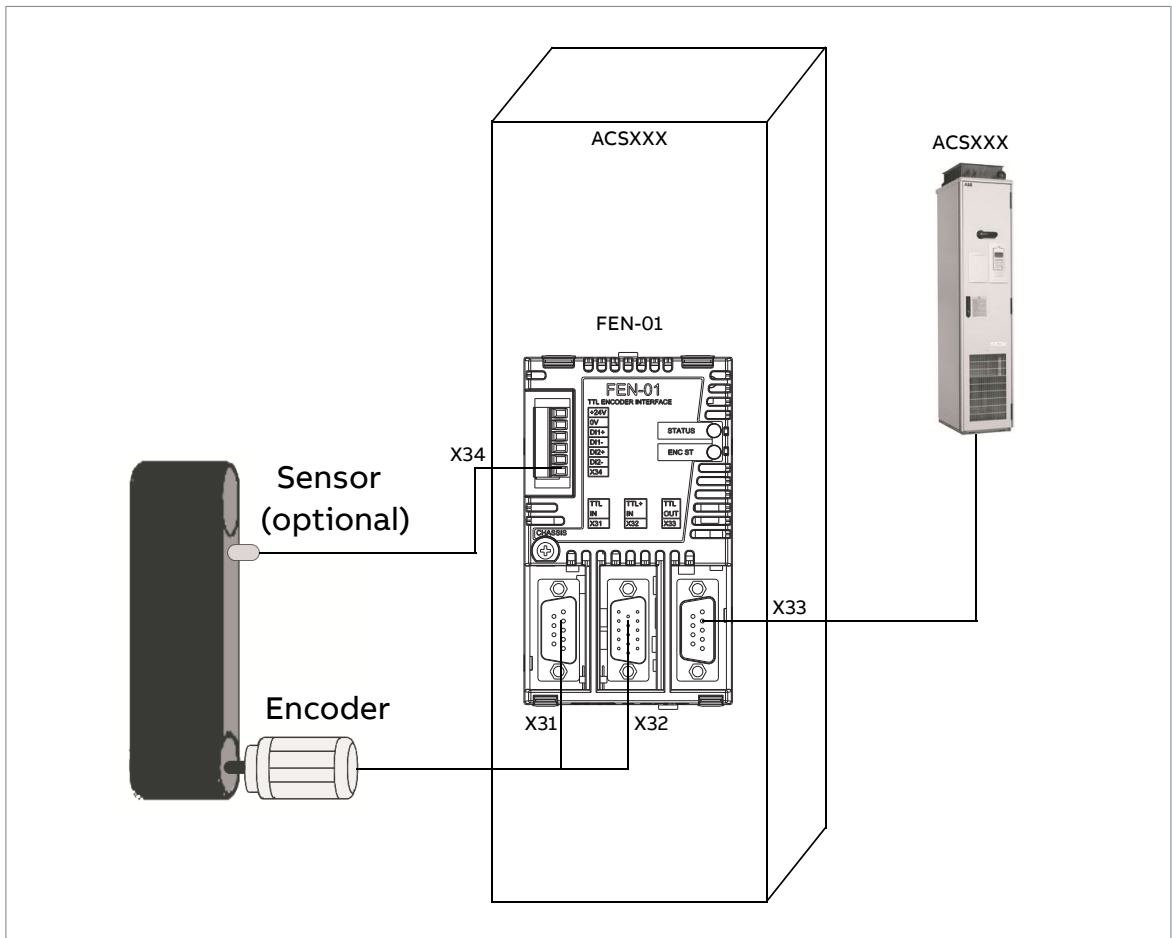

■ **Isolation areas**

The following figure describes the different isolation areas of the module.

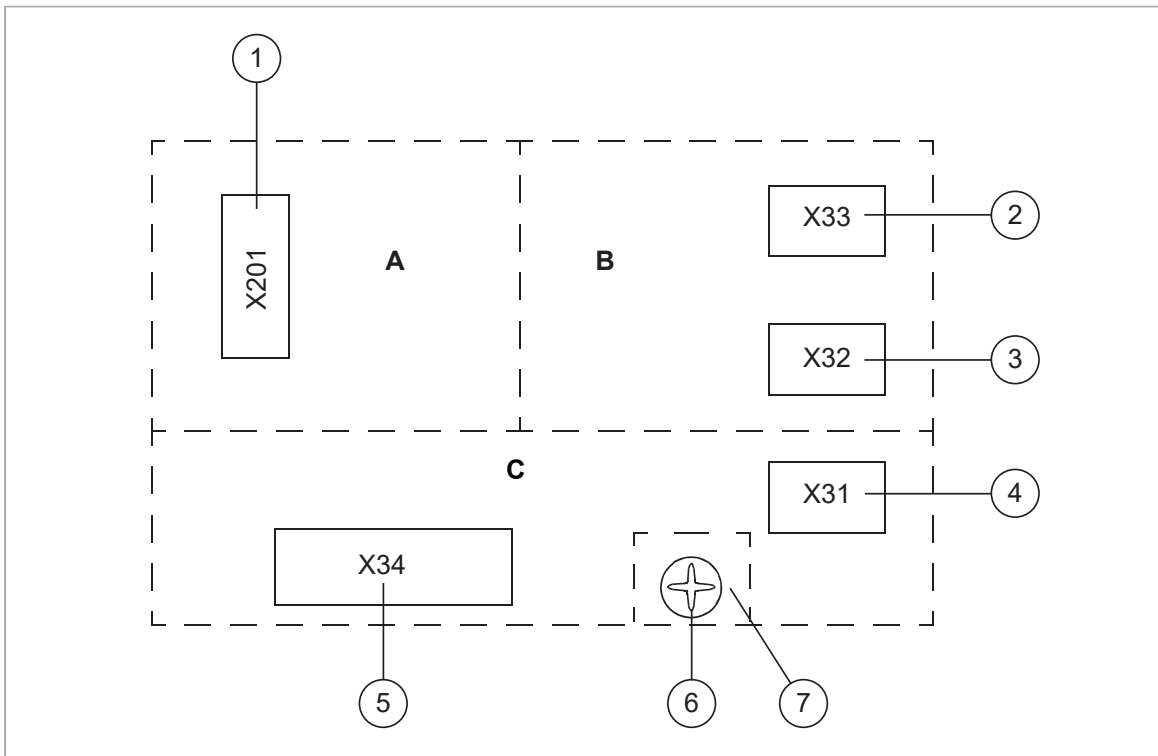

1	Connection to the drive
2	TTL encoder emulation output
3	TTL encoder input with commutation support
4	TTL encoder input
5	Digital latches
6	Fixing screw
7	Chassis

The shields of sockets X31 and X32 and plug X33 are connected to chassis. The fixing screw connects the chassis to ground.

Compatibility

FEN-01 is compatible with the following encoders.

- TTL incremental encoder, 1...65535 pulses/rev, supports reference mark
- TTL incremental encoder, 1...65535 pulses/rev, supports block commutation and reference mark.

4

Installation

Contents of this chapter

This chapter contains instructions on installing the TTL Encoder Interface module.



WARNING!

Follow the safety instructions given in this guide and in the drive's hardware manual.

Setting the supply voltage



WARNING!

Selecting the wrong supply voltage may damage or break the encoder.

A selectable supply voltage is provided for the TTL encoders' input. A +5.5 V or a +24 V voltage for either TTL encoder can be selected by vertically mounted jumpers as described by the following figure.

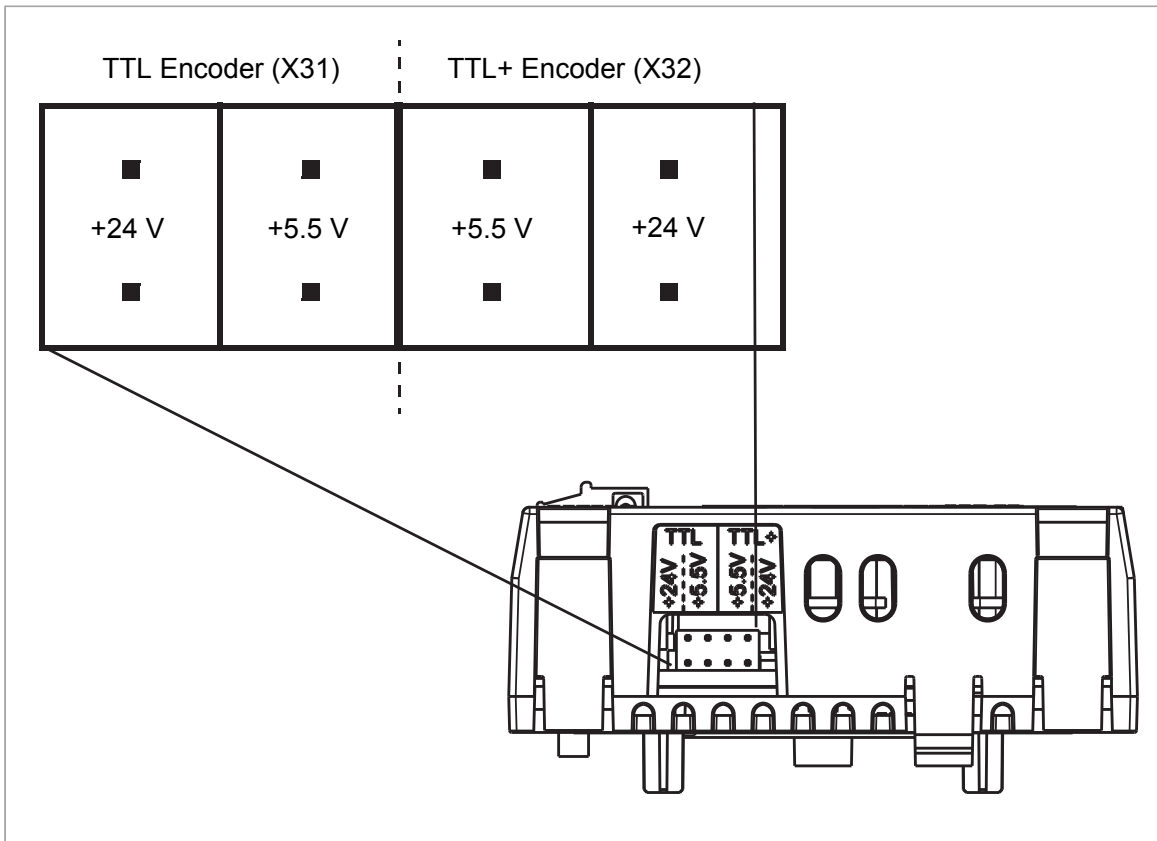

Note: If an external power supply is used, the appropriate jumper must be removed.

Note: If another FEN interface's TTL emulation output is connected to TTL input, the appropriate jumper must be removed.

Mounting



WARNING!

Before installation, do the electrical safety precautions given in section [Safety instructions](#).

Note: Before mounting the option module, set the supply voltage jumpers as described above.

The option module is to be inserted into the option slot of the drive. See the drive hardware manual for more information.

The module is held in place with plastic retaining clips, a locking tab and one screw. The screw also provides the earthing of the cable shields connected to the module and interconnects the GND signals of the module and the drive.

On installation of the module, the signal and power connection to the drive is automatically made through a 20-pin connector.

Numbers in brackets refer to the layout drawing in section layout.

Mounting procedure:

1. Pull out the locking tab (8)
2. Insert the module carefully into the option slot until the retaining clips lock the module into position
3. Push in the locking tab (8)
4. Fasten the screw (included) to the stand-off.

If you need to remove the adapter module after it has been installed into the drive, use a suitable tool (e.g. small pliers) to carefully pull out the locking tab.

Note: Correct installation of the screw is essential for fulfilling the EMC requirements and for proper operation of the module.

Terminal designations

■ Abbreviations

AI	Analog input
DI	Digital input
DO	Digital output
PO	Power output

■ **TTL encoder input (X31)**

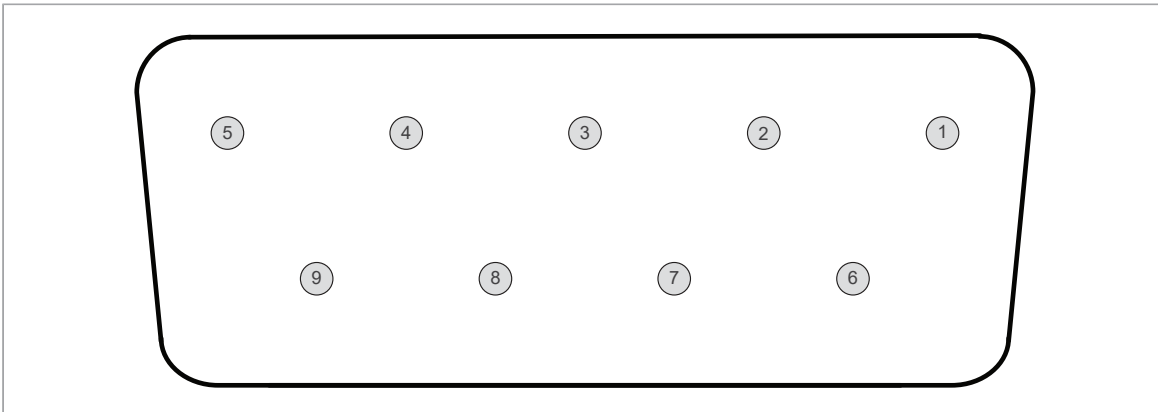

Pin	Name	Direction	Description
1	A+	DI	Channel A+
2	B+	DI	Channel B+
3	Z+	DI	Channel Z+
4	COM_C	-	Common
5	VCC_ENC_1	PO	Supply voltage (5.5 V or 24 V)
6	A-	DI	Channel A-
7	B-	DI	Channel B-
8	Z-	DI	Channel Z-
9	COM_C	-	Common
-	Shield	-	Shield

■ TTL encoder input with commutation signal support (X32)

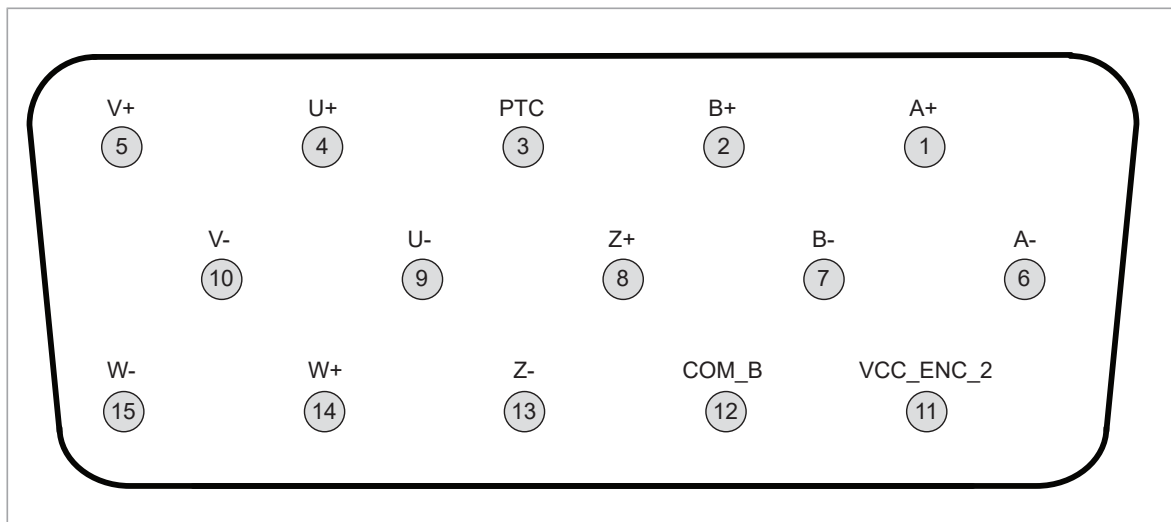

Pin	Name	Direction	Description
1	A+	DI	Channel A+
2	B+	DI	Channel B+
3	PTC	AI	Temperature sensor
4	U+	DI	Channel U+
5	V+	DI	Channel V+
6	A-	DI	Channel A-
7	B-	DI	Channel B-
8	Z+	DI	Channel Z+
9	U-	DI	Channel U-
10	V-	DI	Channel V-
11	VCC_ENC_2	PO	Supply voltage (5.5 V or 24 V)
12	COM_B	-	0V, common
13	Z-	DI	Channel Z-
14	W+	DI	Channel W+
15	W-	DI	Channel W-
-	Shield	-	Shield

■ **TTL encoder emulation output (X33)**

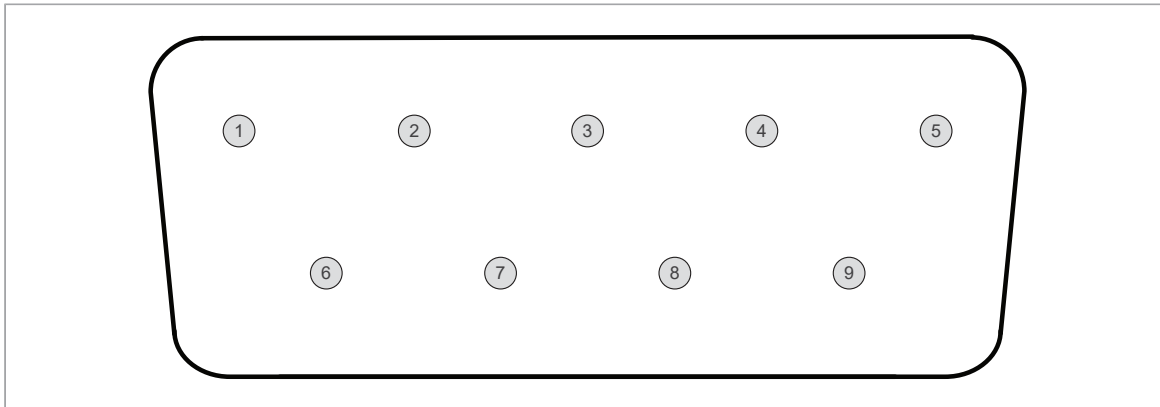

Pin	Name	Direction	Description
1	EM_A+	DO	Channel A+
2	EM_B+	DO	Channel B+
3	EM_Z+	DO	Channel Z+
4	COM_B	-	Common
5	COM_B	-	Common
6	EM_A-	DO	Channel A-
7	EM_B-	DO	Channel B-
8	EM_Z-	DO	Channel Z-
9	COM_B	-	Common
-	Shield	-	Shield

■ **Digital inputs for position latching (X34)**

Pin	Name	Direction	Description
1	+24V_C	PO	Supply voltage
2	COM_C	-	Common
3	DI_1+	DI	Latch signal 1
4	DI_1-	-	Latch signal 1 return
5	DI_2+	DI	Latch signal 2
6	DI_2-	-	Latch signal 2 return

General encoder wiring guidelines

The encoders should be connected to the encoder interface module with a shielded instrumentation cable, preferably with twisted pairs. See the encoder manual for additional requirements. To prevent the encoder inputs from being disturbed, the cable shield must be connected to the chassis. The connection is made automatically through the metal hood of the plug, if the cables are connected through the cable clamp of the plug.

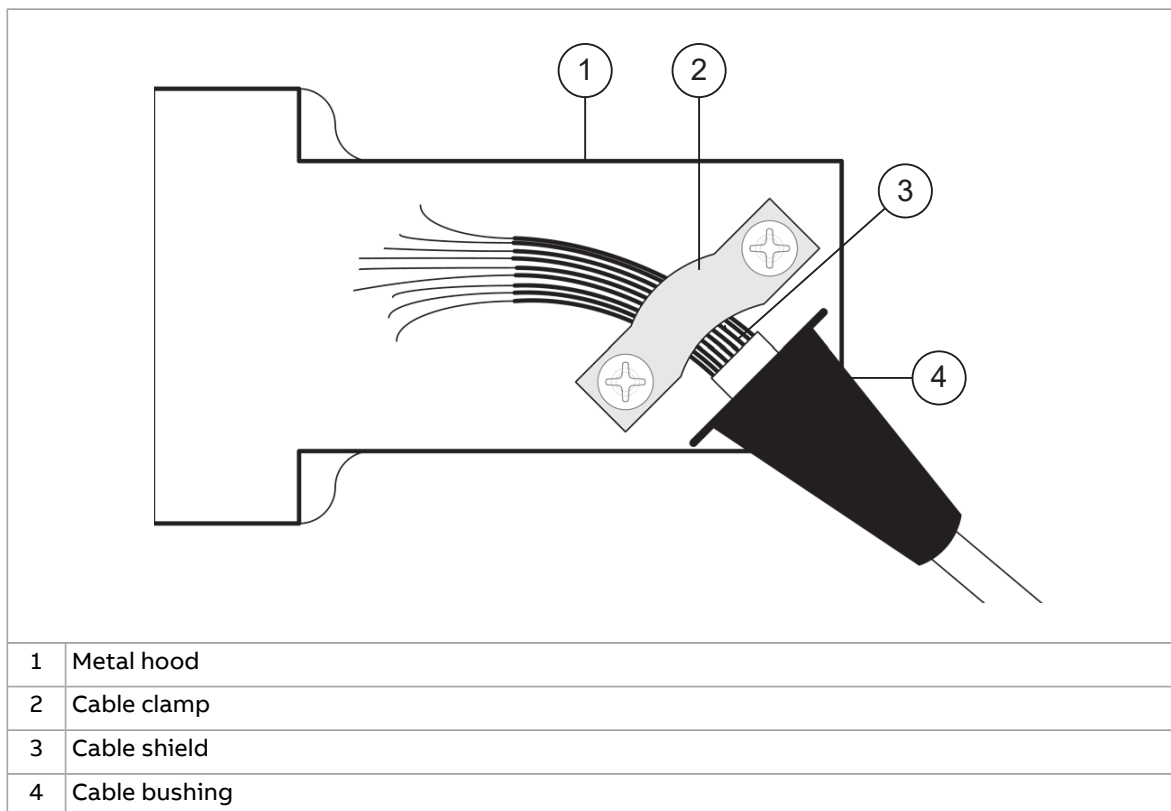

Note: Do not route the encoder cables parallel to power (e.g. motor) cables.

Tightening torque is 0.3 Nm (2.7 lbf-in.) for the plugs.

The allocation of cable pairs is described for each connector in the following sections.

■ **TTL encoder input (X31)**

The cable should have minimum 4 cable pairs. A fifth cable pair shared between Vcc and 0V pins allows for a longer cable.

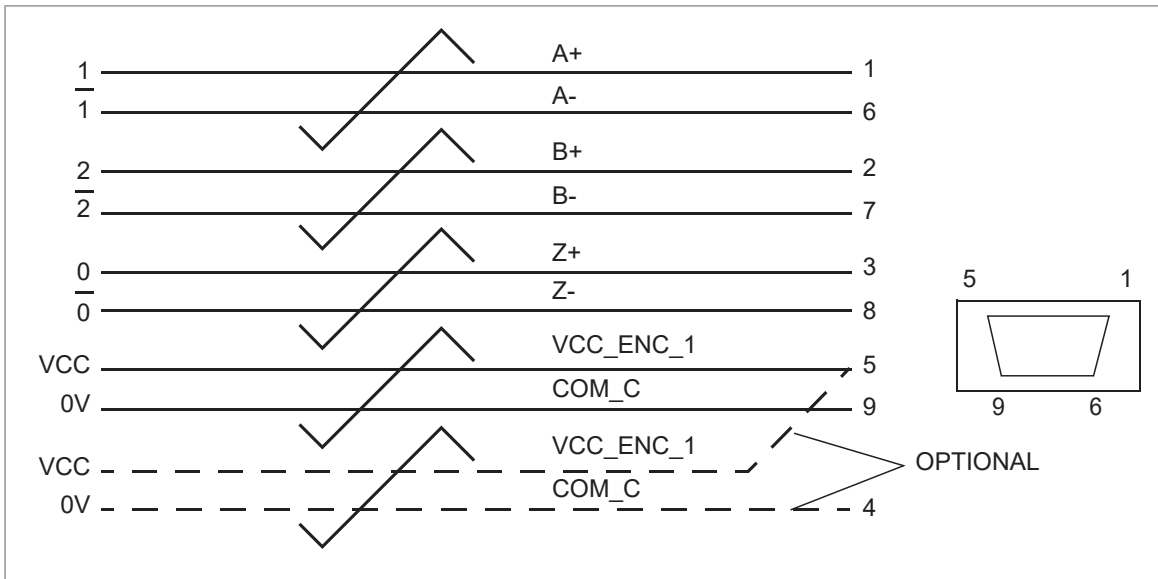

Cable pair number	Signals name	Connecting plug pin number (9-pins)	Notes
1	A+	1	
	A-	6	
2	B+	2	
	B-	7	
3	Z+	3	
	Z-	8	
4	VCC_ENC_1	5	
	COM_C	9	
5	VCC_ENC_1 ¹⁾	5 ¹⁾	OPTIONAL
	COM_C	4	OPTIONAL

¹⁾ Two wires soldered to the same pin.

■ **TTL encoder input with commutation signal support (X32)**

The cable should have minimum 8 cable pairs. An extra pair shared between Vcc and 0 V allows for a longer cable.

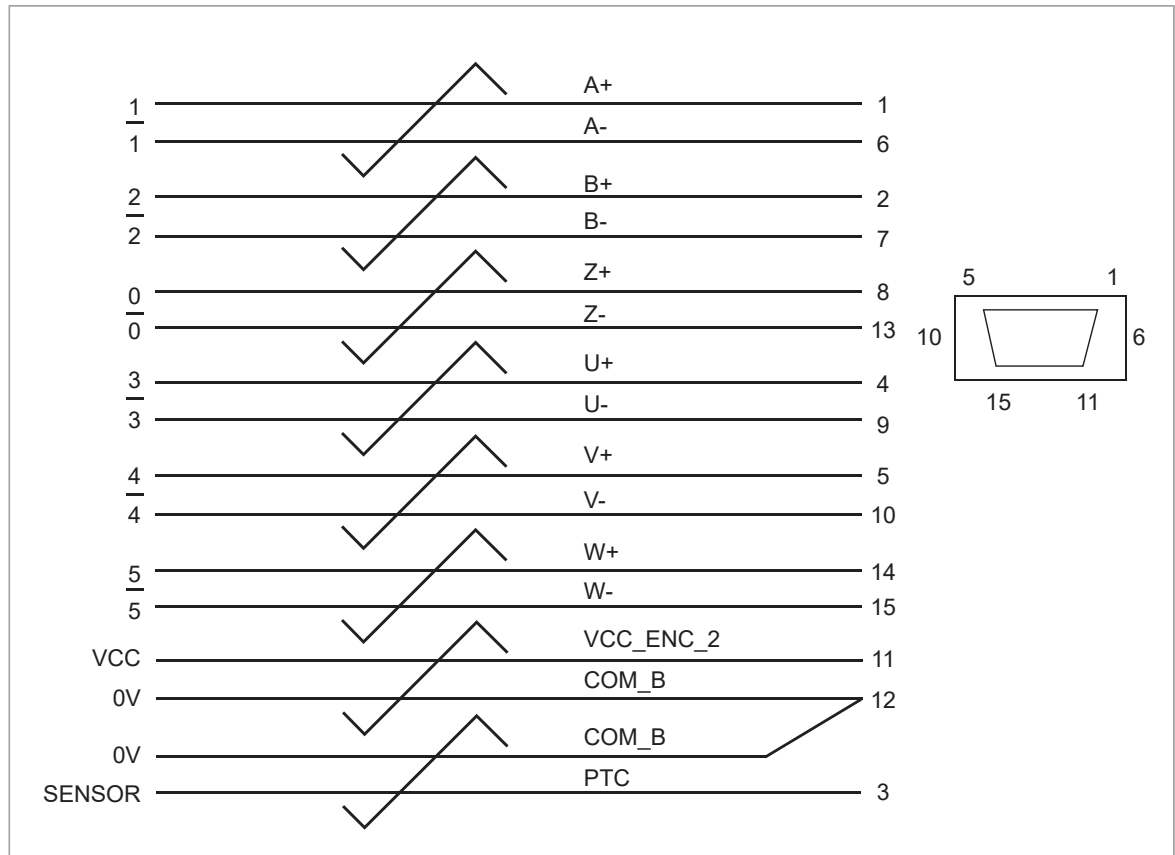

Cable pair number	Signals name	Connecting plug pin number (9-pins)	Notes
1	A+	1	
	A-	6	
2	B+	2	
	B-	7	
3	Z+	8	
	Z-	13	
4	U+	4	
	U-	9	
5	V+	5	
	V-	10	
6	W+	14	
	W-	15	
7	VCC_ENC_2	11	
	COM_B	12	
8	PTC	3	
	COM_B	12 ¹⁾	

1) Two wires soldered to the same pin.



WARNING!

You can connect a motor temperature sensor to the encoder module only if there is double or reinforced insulation between the live parts of the motor and the sensor. The module does not provide a safe isolation from the drive. Refer to the drive manuals for more information.

■ **TTL Emulation output (X33)**

The cable should have 4 cable pairs.

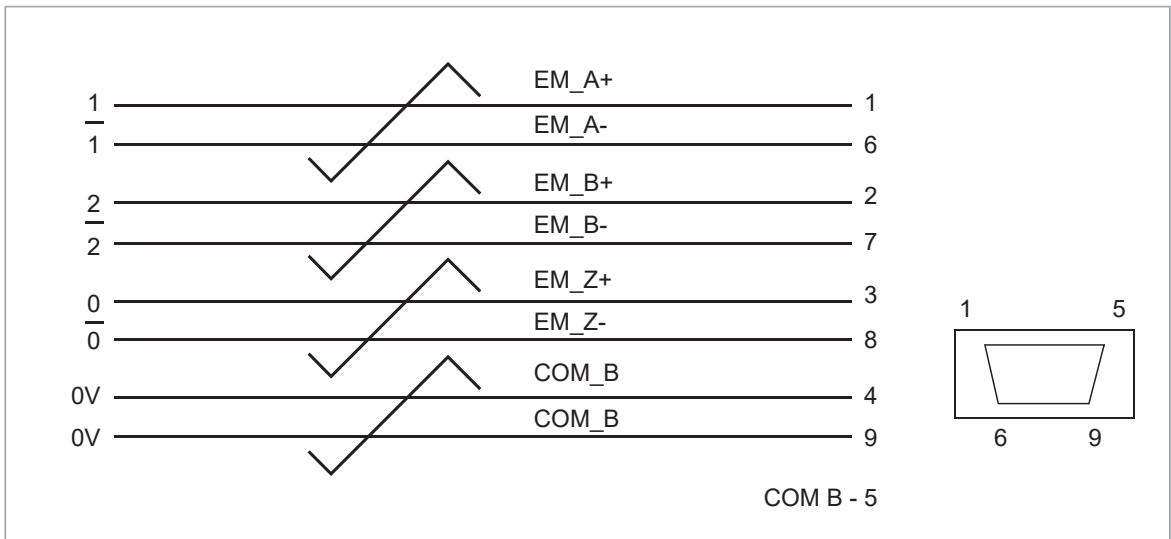

Cable pair number	Signals name	Connecting socket pin number (9-pins)	Notes
1	EM_A+	1	
	EM_A-	6	
2	EM_B+	2	
	EM_B-	7	
3	EM_Z+	3	
	EM_Z-	8	
4	COM_B	4	
	COM_B	9	

■ Digital inputs for position latching (X34)

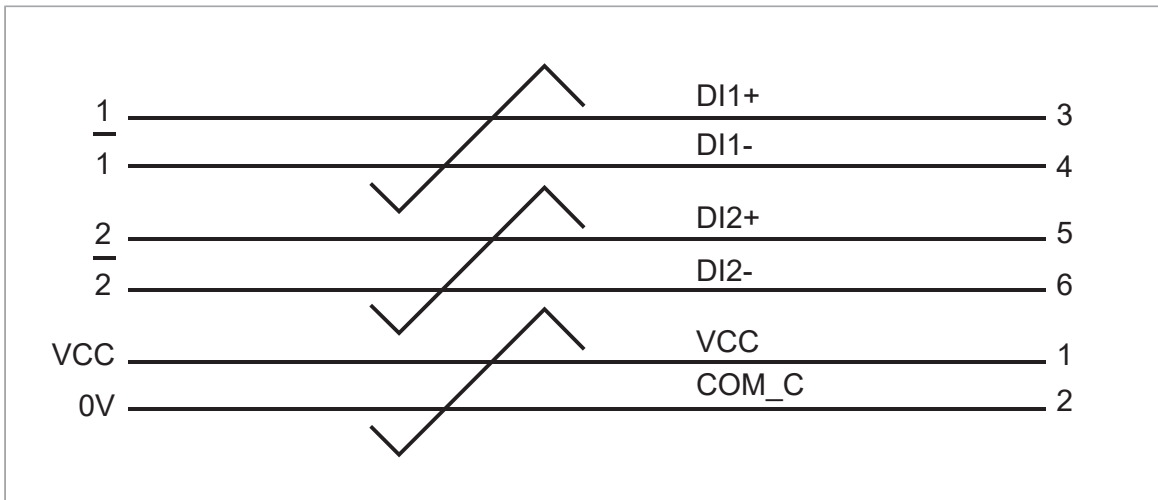

Cable pair number	Signals name	Connecting header pin number (6-pins)	Notes
1	+24V_C	1	
	COM_C	2	
2	DI_1+	3	
	DI_1-	4	
3	DI_2+	5	
	DI_2-	6	

Note: Do not route the encoder cables parallel to power (e.g. motor) cables.

General encoder phasing principle

When the encoder is connected correctly, running the drive in the Forward (positive speed reference) direction should produce a positive encoder feedback.

On incremental encoders, the two output channels, usually marked 1 and 2 or A and B, are 90° (electrical) apart from each other. When rotated clockwise, most encoders have channel 1 leading channel 2 as illustrated below. Determine the leading channel by referring to the encoder documentation or by measuring with an oscilloscope.

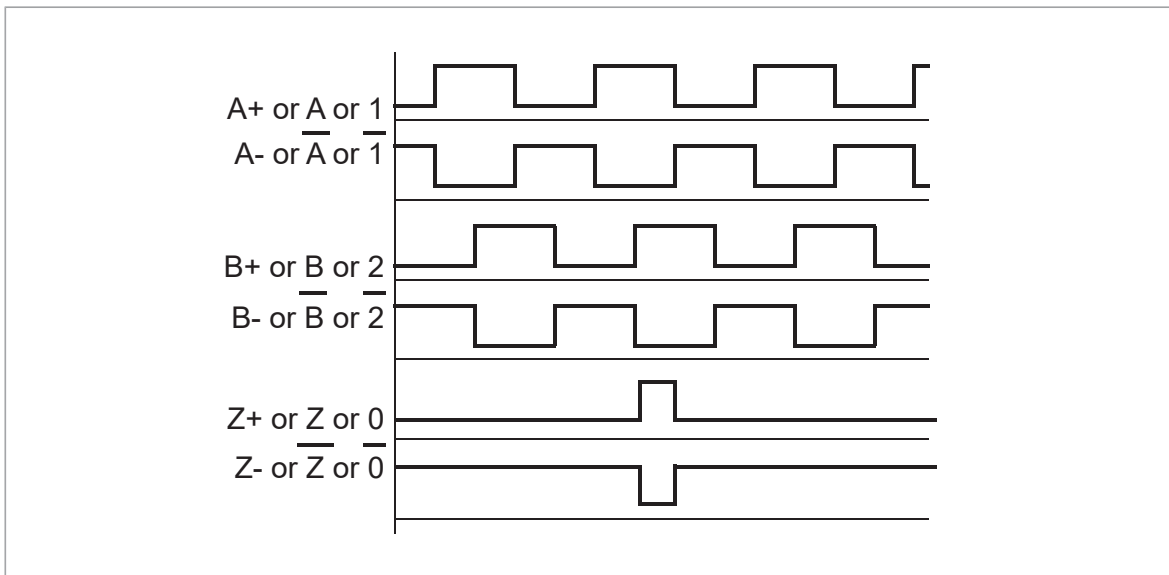

The encoder output channel that leads when the drive runs Forward should be connected to FEN-01 input A, the output channel that trails to FEN-01 input B.

The zero reference output channel (usually marked 0, N or Z) needs to be connected in positioning applications only.

A large, light gray square with rounded corners, centered on the page. Inside the square is a large, bold, black number '5'.

Start-up

Contents of this chapter

This chapter contains instructions on starting up the Encoder Interface module.

Programming

The FEN-01 is programmed through drive parameters. These parameters must be checked and adjusted according to the encoder data sheet. For further information, see the drive Firmware Manual.



Fault tracing

Contents of this chapter

This chapter shows how to trace faults with the status LEDs on the TTL Encoder Interface module.

Diagnostic LEDs

The FEN-01 is equipped with two diagnostic LEDs. The STATUS LED describes the status of the FEN-01 and the ENC ST LED the status of the encoders. Description of the LED signals is presented below.

	Colour	Description
STATUS LED	Green	OK
	Orange	Not initialized or communication fault to control unit
	Red	Not in use
ENC ST LED	Green	Encoder(s) OK
	Red	TTL encoder (X31) fault
	Orange	TTL + encoder (X32) fault
	Red/orange swapping	TTL encoder fault X31 and TTL + encoder X32 fault
	Red flashing	TTL encoder (X31) warning
	Orange flashing	TTL + encoder (X32) warning

Note: When using FEN-01 with ACS880 the status of ENC ST LED is updated after encoder fault reset is done.



7

Technical data

Contents of this chapter

This chapter contains the technical data of the TTL Encoder Interface module.

Dimensions

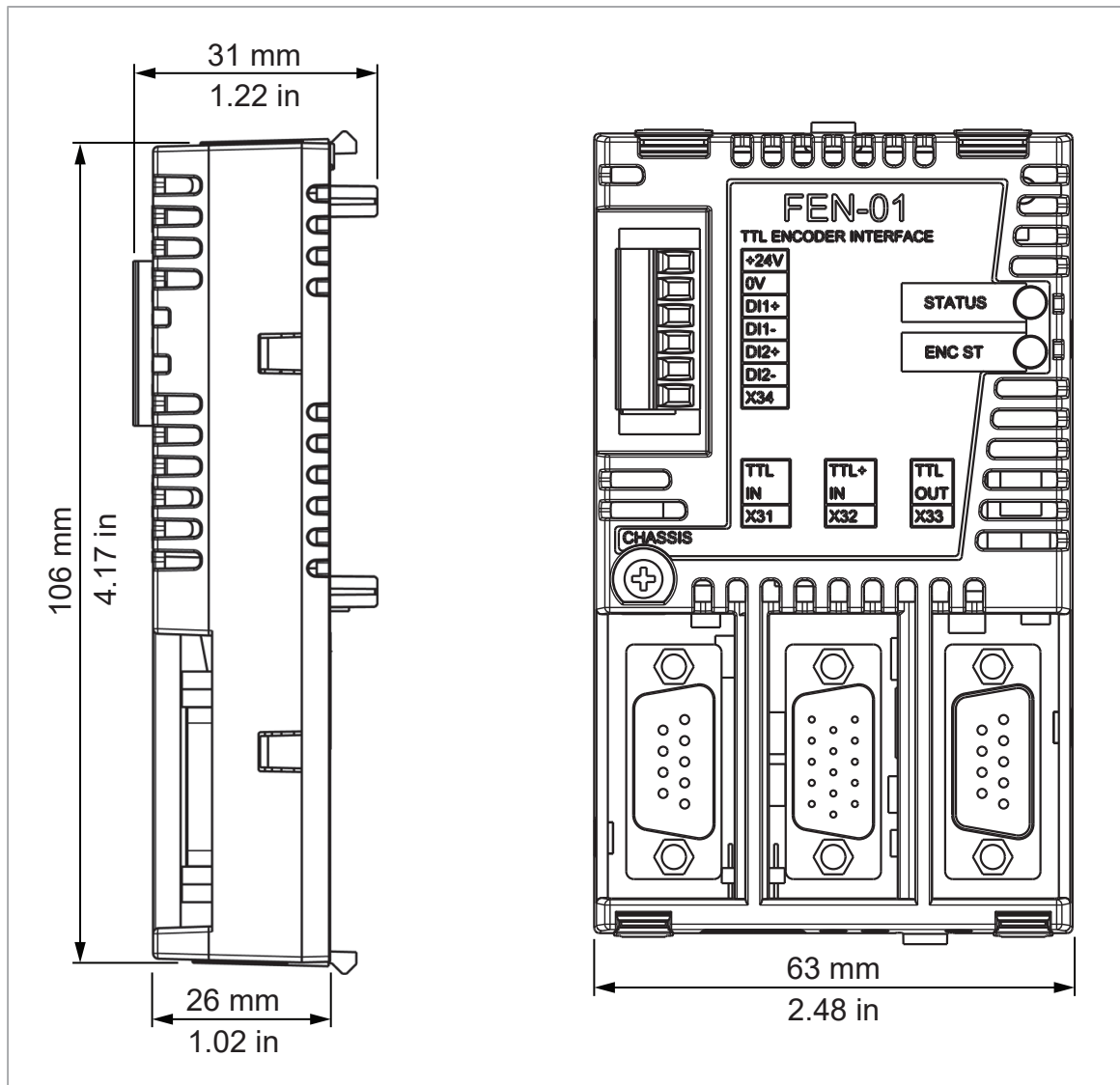

General

Max. power consumption	350 mA at 24 V (Max. combined power consumption of encoders, latches and cabling 5W)
Degree of protection	IP20
Ambient conditions	The applicable ambient conditions specified for the drive in its Hardware Manual are in effect.

Connectors

- 20-pin socket
- 9-pin D-sub socket
- 15-pin D-sub socket
- 9-pin D-sub plug
- 6-pin header

TTL encoder input (X31)

Output voltages	+5.5 V DC -5%, -8%, 180 mA
	+24 V DC $\pm 15\%$, 150 mA together with digital inputs
	+5.5 V and +24 V combined maximum power is 3.6 W
CH A, CH B, CH Z	RS-422/485, differential, 500 kHz (max)
Maximum cable length	30 m with a 5 V encoder (0.5 mm ² cable for power supply)
	60 m with a 5 V encoder (two parallel 0.5 mm ² cables for power supply)
	100 m with a 10...30 V TTL incremental encoder
Performance	Speed range: -32768...32767 rpm
	Speed resolution: 0.004 rpm (24 bits)
	Position resolution: 16.8 M/rev (24 bits)
	Position accuracy: 4x pulse count/rev
Isolation	Isolated together with digital inputs

TTL encoder input with commutation support (X32)

Output voltages	+5.5 V DC +2.5%, -1%, 200 mA
	+24 V DC $\pm 15\%$, 150 mA
Thermistor	PTC thermistor input
CH A, CH B, CH Z, CH U, CH V, CH W	RS-422/485, differential, 500 kHz (max)
Maximum cable length	30 m with a 5 V encoder (0.5 mm ² cable for power supply)
	60 m with a 5 V encoder (two parallel 0.5 mm ² cables for power supply)
	100 m with a 10...30 V TTL encoder
Performance	Speed range: -32768...32767 rpm
	Speed resolution: 0.04 RPM (24 bits)
	Position resolution: 16 M/rev (24 bits)
	Position accuracy: 4x pulse count/rev
Isolation	Isolated together with TTL encoder emulation output

TTL encoder emulation output (X33)

Emulation	Supports emulations of TTL incremental encoder, 1...65535 pulses/rev, reference mark
CH A, CH B, CH Z	RS-422/485, 500 kHz (max)
Maximum cable length	100 m
Performance	Speed range: -32768...32767 rpm
	Position resolution: 4x pulse count/rev
Isolation	Isolated together with encoder input

Digital inputs for position latch (X34)

Output voltage	+24 V DC \pm 15%, short-circuit proof
Signal levels	< 5 V = 0, > 15 V = 1
Isolation	Isolated together with TTL encoder input

Further information

Product and service inquiries

Address any inquiries about the product to your local ABB representative, quoting the type designation and serial number of the unit in question. A listing of ABB sales, support and service contacts can be found by navigating to www.abb.com/searchchannels.

Product training

For information on ABB product training, navigate to new.abb.com/service/training.

Providing feedback on ABB manuals

Your comments on our manuals are welcome. Navigate to new.abb.com/drives/manuals-feedback-form.

Document library on the Internet

You can find manuals and other product documents in PDF format on the Internet at www.abb.com/drives/documents.



www.abb.com/drives



3AFE68784603E