

# TB4043

## Conductivity sensor

### Sanitary toroidal

Unique 3A sanitary certification  
for food and beverage  
applications



#### Integral 2-inch tri-clamp sanitary flanges

- Mates to sanitary clamp, ferrule or tee

#### 100% Virgin PEEK™ polymer

- Assures chemical resistance, durability and 3A compliance

#### Multi-range capability

- Measures from 100  $\mu\text{S}/\text{cm}$  to 2,000  $\text{mS}/\text{cm}$

#### Small size with large bore

- Center hole much larger than comparatively sized competitors sensors

#### Inductive measurement technique

- Greatly reduces coating and other fouling problems yielding a measurement virtually unaffected by solution contaminants

## General Description

Model TB4043 sanitary toroidal conductivity sensors expand the advancements in process conductivity measurement initiated by ABB with 4-electrode conductivity measurement. Unlike 4-electrode sensors, toroidal sensors have no electrodes or metals exposed to the measured solution.

Sanitary toroidal conductivity measurement is applicable to a wide variety of process needs including dairy, food and beverage, pharmaceutical, clean-in-place, brine, cheese souring, lye peeling, and countless other applications.

The Model TB4043 toroidal sensor provides a means for measuring solution conductivity in aggressive solutions that corrode, foul or otherwise destroy electrode type sensors. The sensor itself is comprised of two wound toroids encapsulated in chemically resistant nonconductive PEEK™ polymer. Measurement is inductive, made by magnetic coupling between the solution and the toroids. Inductive measurement can be made without electrodes which are affected by erroneous resistances from coatings. The Model TB4043 toroidal sensors are virtually impervious to all but thick layers of coatings.

## Materials

The wetted surface of the Model TB4043 toroidal sensor is virgin PEEK polymer, which is compatible in a wide range of solutions. PEEK polymer is a member of the polyaryletherketone family, a linear aromatic thermoplastic that possesses high temperature mechanical properties and chemical resistance.

The sanitary tri-clamp flange is supported from behind by a non-wetted, 316 stainless steel back designed to increase strength and safety. The wetted material used is virgin PEEK polymer, a 3-A approved material for use in dairy, food and beverage, and pharmaceutical applications.

## 3-A Approval

The tri-clamp Model TB4043 toroidal sensor is designed to the 3-A Sanitary Standards formulated by the International Association of Milk, Food, and Environmental Sanitarians; the United States Public Health Service; and the Dairy Industry Council. For additional information regarding 3-A, contact 3-A Sanitary Standards Inc. or visit their website at [www.3-a.org](http://www.3-a.org).

## Toroidal Conductivity Theory

Toroidal conductivity measurement is performed without using any electrodes in contact with the process solution. Instead, two wound toroids encapsulated in a nonconductive chemical resistant material such as PEEK polymer comprise the sensor.

The transmitter supplies a constant drive to one of the toroids. This drive toroid generates a strong magnetic field in the solution. This magnetic field induces a current in the solution which magnetically couples the second toroid. This second or sensing toroid then generates a current that varies directly with the amount of coupling occurring through the solution. Since the induced current varies proportionally with the conductance of the solution, the signal measured by the sense toroid is directly related to solution conductivity.

The nonconductive sensor material is not affected by process coating or scale that adds resistance and error to conventional conductivity measurement. Only coatings thick enough to significantly obscure the cross sectional area of the sensor bore will degrade measurement accuracy.

## Temperature Compensation

Solution conductivity is greatly affected by temperature. Compensation for the affects of temperature on solution conductivity (temperature compensation) is accomplished by an RTD in the sensor and specific circuitry in the associated instrument.

| Property                 | Characteristic / Value   |
|--------------------------|--|
| Process Connection       | 2-inch tri-clamp sanitary fitting  |
| Wetted Materials         | PEEK polymer   |
| Non-wetted Materials     | 316 stainless steel backing tri-clamp flange   |
| Temperature / Pressure   | 100 psig (689 kPa) at 250°F (121°C)  |
| Measurement Range        | Minimum 100 µS/cm / Maximum 2,000 mS/cm  |
| Temperature compensation | Pt 1000  |
| Approvals                | 3-A Standard 74-02 (Authorization No. 896) formulated by 3-A Sanitary Standards Inc. |

**Overall Dimensions**

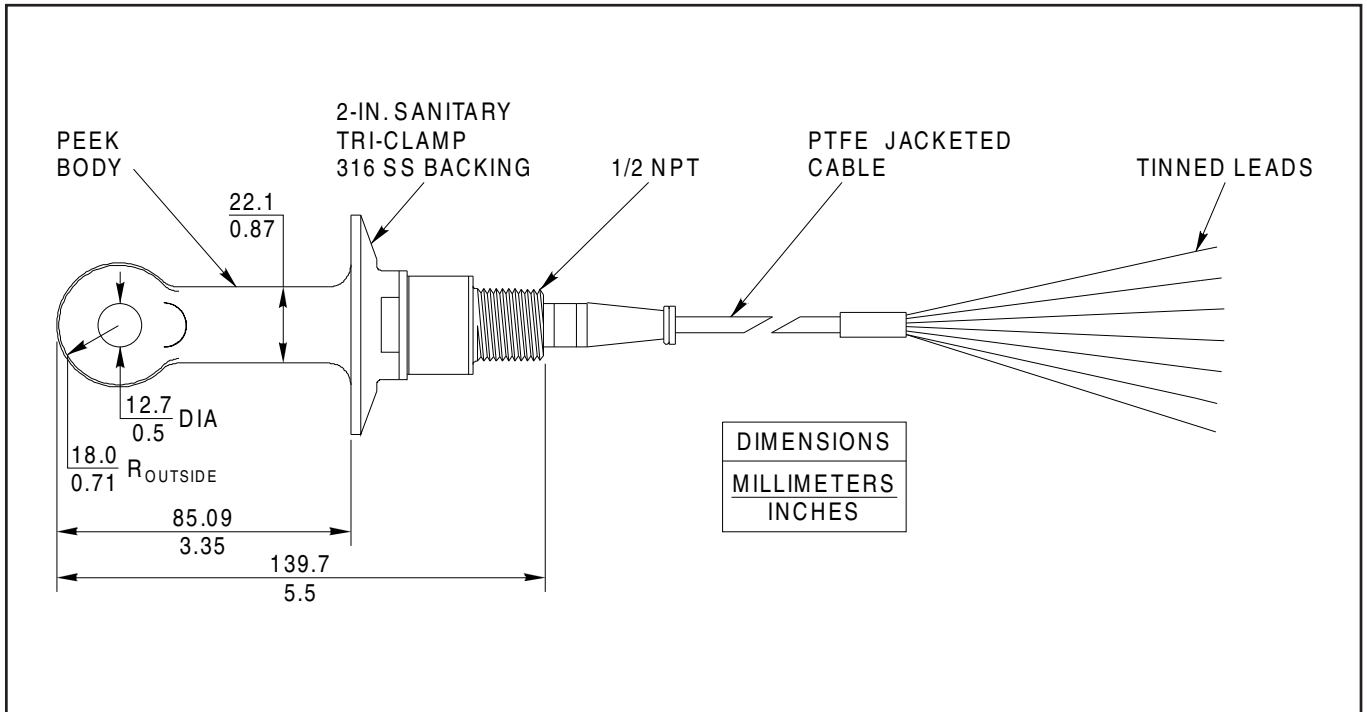

**Toroidal Conductivity Measurement**

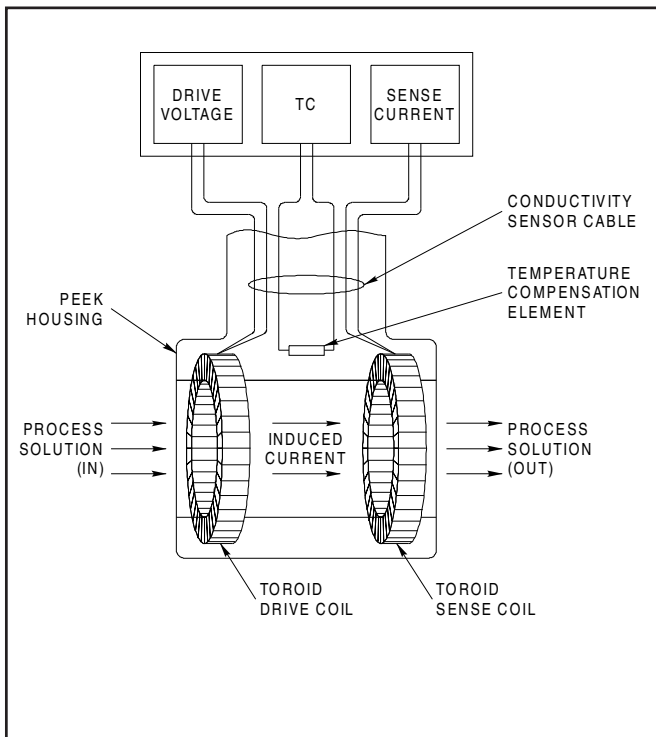

**Ordering Information**

|  |                    | Model number |          |
|--|--------------------|--------------|----------|
| <b>Base Model Model</b>  | <b>TB404320000</b> | <b>X</b>     | <b>X</b> |
| Sanitary PEEK polymer, 2-inch tri-clamp, stainless steel back, |                    |              |          |
| Integral Pt 1000 temperature compensator                       |                    |              |          |
| <b>Cable Length – 12<sup>th</sup> character</b>                |                    |              |          |
| 1.5 m (5 ft)   |                    | 1            |          |
| 3.1 m (10 ft)  |                    | 2            |          |
| 4.6 m (15 ft)  |                    | 3            |          |
| 6.1 m (20 ft)  |                    | 4            |          |
| 9.1 m (30 ft)  |                    | 5            |          |
| 12.2 m (40 ft)   |                    | 6            |          |
| 15.2 m (50 ft)   |                    | 7            |          |
| <b>Identification Tag – 13<sup>th</sup> character</b>          |                    |              |          |
| None   |                    | 0            |          |
| Mylar  |                    | 1            |          |
| Stainless Steel  |                    | 2            |          |

# Contact us

## **ABB Inc.**

### **Process Automation**

843 N Jefferson Street

PO Box 831

Lewisburg 24901-9509

USA

Tel: +1 800 HELP 365 (435 7365)

Fax: +1 304 647 1862

## **ABB Limited**

### **Process Automation**

Oldends Lane

Stonehouse

Gloucestershire GL10 3TA

UK

Tel: +44 1453 826 661

Fax: +44 1453 829 671

## **ABB Engineering (Shanghai) Ltd.**

### **Process Automation**

No. 5, Lane 369, Chuangye Road

201319, Shanghai,

P.R. China

Phone: +86 (0) 21 6105 6666

Fax: +86 (0) 21 6105 6992

Mail: china.instrumentation@cn.abb.com

[www.abb.com](http://www.abb.com)

## Note

We reserve the right to make technical changes or modify the contents of this document without prior notice. With regard to purchase orders, the agreed particulars shall prevail. ABB does not accept any responsibility whatsoever for potential errors or possible lack of information in this document.

We reserve all rights in this document and in the subject matter and illustrations contained therein. Any reproduction, disclosure to third parties or utilization of its contents – in whole or in parts – is forbidden without prior written consent of ABB.

Copyright© 2013 ABB

All rights reserved

3KXA111403R1001