

# MNS Motor Management INSUM®

MCU User's Guide  
Version 3.0d



**ABB**





**INSUM<sup>®</sup>**  
**MCU User's Guide**

Software Version 3.0d

## **NOTICE**

The information in this document is subject to change without notice and should not be construed as a commitment by ABB Automation Products GmbH. ABB Automation Products GmbH assumes no responsibility for any errors that may appear in this document.

In no event shall ABB Automation Products GmbH be liable for direct, indirect, special, incidental, or consequential damages of any nature or kind arising from the use of this document, nor shall ABB Automation Products GmbH be liable for incidental or consequential damages arising from use of any software or hardware described in this document.

This document and parts thereof must not be reproduced or copied without ABB Automation Products GmbH's written permission, and the contents thereof must not be imparted to a third party nor be used for any unauthorized purpose. Permission to translate the document shall be obtained from ABB Automation Products GmbH. The translated document shall be sent to ABB Automation Products GmbH together with the confirmation that the content of the document is the same.

The software described in this document is furnished under a license and may be used, copied, or disclosed only in accordance with the terms of such license.

© 2006 ABB Automation Products GmbH, Germany

## **TRADEMARKS**

MNS and INSUM are registered trademarks of ABB Schaltanlagentechnik GmbH

Microsoft, Windows and Windows NT are registered trademarks of Microsoft Corporation.

Echelon, LON, LONWORKS, LonTalk, Neuron are trademarks of Echelon Corporation registered in U.S. and other countries.

Reference document 1SCA022678R2300B ABB Control Oy Finland



<b>1</b>	<b>Introduction .....</b>	<b>5</b>
1.1	Objective .....	5
1.2	Related Documentation .....	5
<b>2</b>	<b>Product Overview .....</b>	<b>6</b>
2.1	MCU in general .....	6
2.2	Type designation .....	7
2.3	Mechanical structure .....	7
2.3.1	MCU units .....	7
2.3.2	MCU enclosure material .....	7
<b>3</b>	<b>MCU Interfaces .....</b>	<b>8</b>
3.1	MCU connectors .....	8
3.1.1	Connector designations .....	8
3.1.2	Connector locations .....	9
3.1.3	Internal/external connector for I/O .....	9
3.2	Power supply .....	10
3.2.1	Nominal Input Voltage .....	10
3.2.2	Power consumption .....	10
3.3	Digital input .....	11
3.4	LED output .....	12
3.4.1	LED output terminals .....	12
3.4.2	LED functionality .....	12
3.5	Contactorm watchdog signalling output .....	13
3.6	Contactorm control output .....	13
3.7	General purpose digital input .....	14
3.8	General purpose digital output .....	14
3.9	Analog output .....	14
3.10	Rotation monitor .....	15
3.11	PTC input .....	15
3.12	Fieldbus interface .....	15
3.13	Residual current transformer .....	16
3.14	Motor phase currents .....	16
3.14.1	Current measurement terminals .....	16
3.14.2	Intermediate current measurement .....	17
3.15	Voltage measurement .....	17
3.15.1	Voltage measurement connector .....	17
3.15.2	Power factor calculation .....	18
<b>4</b>	<b>MCU functionality .....</b>	<b>19</b>
4.1	Starter types .....	19
4.1.1	MCU starter types .....	19
4.1.2	Parameters .....	20
4.1.3	Starter types requiring feedback supervision .....	20
4.1.4	NR-DOL starter .....	20
4.1.5	REV-DOL starter .....	21
4.1.6	NR-DOL and REV-DOL starter with latched option .....	22
4.1.7	NR-DOL and REV-DOL for softstarter applications .....	24
4.1.8	NR-DOL/RCU starter .....	26
4.1.9	REV-DOL/RCU starter .....	28
4.1.10	NR-S/D starter .....	29
4.1.11	REV-S/D starter .....	30
4.1.12	NR-2N starter .....	32
4.1.13	REV-2N starter .....	34
4.1.14	Actuator starter .....	35
4.1.15	Autotransformer starter .....	37
4.2	Protection functions .....	39
4.2.1	Protection functionality .....	39
4.2.2	Protection functions disabled .....	39
4.2.3	Protection functions supported .....	40
4.2.4	Thermal overload protection .....	40
4.2.5	Phase loss protection .....	48
4.2.6	Underload protection .....	49
4.2.7	Underload cosphi protection .....	49
4.2.8	No load protection .....	50
4.2.9	Stall protection .....	51



4.2.10	Earth fault protection .....	51
4.2.11	Unbalance protection .....	52
4.2.12	Rotation monitor protection .....	53
4.2.13	Thermal protection .....	54
4.2.14	Undervoltage protection .....	54
4.2.15	Start limitation protection .....	56
4.2.16	Start interlock protection .....	57
4.3	MCU function and supervision .....	57
4.3.1	Contactor watchdog .....	57
4.3.2	Device self supervision .....	57
4.3.3	Feedback supervision .....	57
4.3.4	Main switch in test position .....	60
4.3.5	Miniature circuit breaker release .....	60
4.3.6	Emergency stop .....	60
4.3.7	External trip .....	60
4.3.8	Main switch trip .....	60
4.3.9	General purpose interface .....	61
4.3.10	Contactor switch cycles .....	62
4.3.11	Motor running hours .....	62
4.3.12	Failsafe functionality .....	62
4.4	Time synchronization .....	63
4.5	MCU Remote/Local control .....	64
4.5.1	Terminology .....	64
4.5.2	Remote/Local control switching .....	64
4.5.3	Remote control access (CA) .....	64
<b>5</b>	<b>MCU communication interface .....</b>	<b>65</b>
5.1	Protocol and functions .....	65
5.2	MCU set-up .....	65
5.2.1	Network installation and configuration .....	65
5.2.2	Service / Wink installation .....	65
5.3	Network variable data .....	65
5.3.1	LON Standard Network Variable Types (SNVT) .....	65
5.3.2	Self Identification and Self Documentation information (SI/SD) .....	65
5.3.3	Network variables background update .....	65
5.4	Internal files .....	66
5.4.1	Device data file .....	66
5.4.2	Alarm and event buffers .....	66
5.5	Alarms and events .....	66
<b>6</b>	<b>MCU Parameterisation .....</b>	<b>68</b>
6.1	Overview .....	68
6.2	MCU parameters .....	68
<b>7</b>	<b>Technical Data .....</b>	<b>69</b>
<b>8</b>	<b>Standards and Approvals .....</b>	<b>72</b>
8.1	Standards .....	72
8.2	EMC compatibility .....	72
8.3	EMC compatibility .....	72
<b>Appendix A. Terminal descriptions .....</b>		<b>73</b>
<b>Appendix B. Parametering failure codes .....</b>		<b>76</b>
<b>Appendix C. MCU1 and MCU2 digital input configuration .....</b>		<b>79</b>
<b>Appendix D. MCU SW and HW functional reference guide .....</b>		<b>80</b>
<b>Appendix E. List of Pictures and Tables .....</b>		<b>83</b>
<b>Appendix F. Terms and Abbreviations .....</b>		<b>86</b>

**Notes:**

## **1 Introduction**

### **1.1 Objective**

The objective of this Users Ganual is to provide the technical information of Motor Control Unit (MCU). This manual should be studied carefully before installing, parameterizing or operating the Motor Control Unit. It is expected that the user has a basic knowledge of physical and electrical fundamentals, electrical wiring practices and electrical components.

The manual refers to INSUM MCU Hardware –4, Software V3.0d.

This document should be used along with the MCU Parameter Description V3.0d, which provides detailed information about parameters and their applications.

For more information on the INSUM system, please see documentation as mentioned in section 1.2.

### **1.2 Related Documentation**

1TGC 901007 B0203 INSUM Technical Information  
1TGC 901027 M0201 INSUM MCU Parameter Description V3.0d  
1TGC 901034 M0202 INSUM MMI Operating Instruction V2.3  
1TGC 901042 M0202 INSUM Modbus Gateway Manual V2.3  
1TGC 901052 M0202 INSUM Profibus Gateway Manual V2.3  
1TGC 901060 M0202 INSUM Ethernet Gateway Manual V2.3  
1TGC 901080 M0203 INSUM System Clock Manual V2.3  
1TGC 901090 M0202 INSUM Control Access Guide V2.3  
1TGC 901091 M0202 INSUM Failsafe Guide V2.3  
1TGC 901092 M0202 INSUM Dual Redundancy Guide V2.3  
1TGC 901093 M0202 INSUM Network Management Guide V2.3

Notes:

## 2 Product Overview

### 2.1 MCU in general

Motor Control Unit (MCU) is a product range of electronic motor control and protection devices with a fieldbus interface. Typically MCU is located into the motor starter, where it's main task is protection, control and monitoring of a 3-phase/1-phase AC motor and motor starter equipment. MCU is connected to the other starter equipment via digital and analog I/O and to other MCU and control system(s) via fieldbus interface. The product range of MCU offers two variations of devices:

- MCU1 is a basic low-end motor controller device for motor and starter equipment protection, control and monitoring.
- MCU2 is a high-end motor controller device based on the MCU1. MCU2 offers more comprehensive set of motor and starter equipment protection, control and monitoring functions. Additionally some process control related functions are included.

The functionality is presented in a list format in appendix 'MCU HW and SW FUNCTIONAL REFERENCE'.

**Picture 1.** MCU2 with voltage unit.



**Picture 2.** INSUM system configuration with Motor Control Units (MCU).

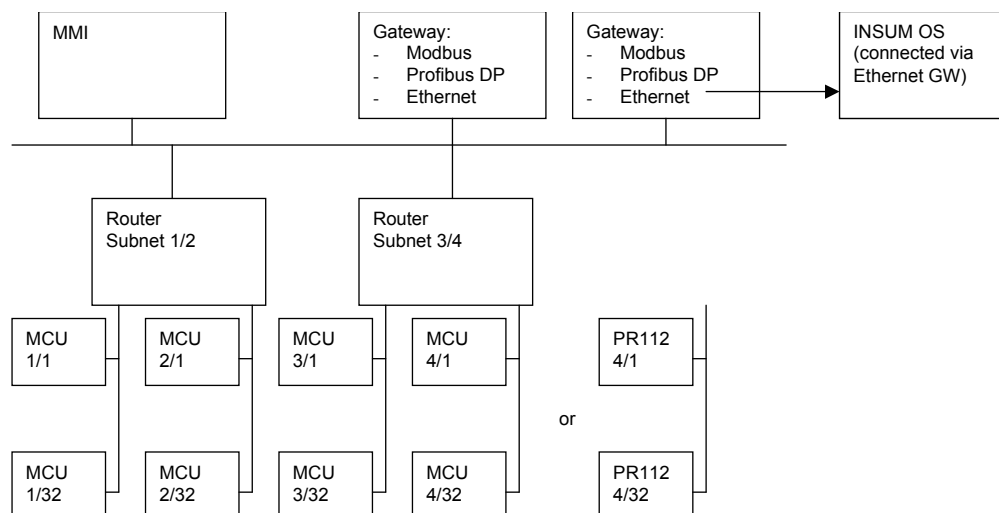



**Notes:**

**2.2 Type designation**

The following table lists available MCU1 and MCU2 types with hardware –4:

**Table 1.** MCU hardware –4 type designation

Type designation	Functionality	I <sub>n</sub>	V <sub>meas</sub>	U <sub>aux1</sub>	U <sub>aux2</sub>
MCU1A01C0-4	MCU1	0,1-3,2 A	-	24 VDC	-
MCU1A02C0-4	MCU1	2,0-63 A	-	24 VDC	-
MCU2A01C0-4	MCU2	0,1-3,2 A	-	24 VDC	-
MCU2A02C0-4	MCU2	2,0-63 A	-	24 VDC	-
MCU2A01V2-4	MCU2	0,1-3,2 A	380-690 VAC	24 VDC	-
MCU2A02V2-4	MCU2	2,0-63 A	380-690 VAC	24 VDC	-
MCU2AB1V2-4	MCU2	0,1-3,2 A	380-690 VAC	24 VDC	230 VAC
MCU2AB1V2-4	MCU2	2,0-63 A	380-690 VAC	24 VDC	230 VAC

**2.3 Mechanical structure**

**2.3.1 MCU units**

MCU consists of four parts:

- Baseplate
- Main Unit
- Current Measurement Unit
- Voltage Unit (option for MCU2 only)

**Baseplate**

Baseplate is a unit mechanically fixed to drawer mounting rail. All the outgoing/incoming wires of the MCU (except main currents and PTC) are connected to Baseplate. Main Unit and Current Measurement Unit are plugged to Baseplate.

**Main Unit**

Main Unit is a unit containing the electronics of the motor control unit. Main unit is plugged to the Baseplate.

**Current Measurement Unit**

Current Measurement Unit contains the current measurement transformers. It is plugged to the Baseplate and additionally fixed by the Main Unit. 2 primary ranges are available: 0.1...3.2 A and 2.0...63 A

**Voltage Unit (option for MCU2 only)**

Voltage Unit contains three phase voltage measurement transformers and electronics for auxiliary power supply 2 (U<sub>AUX2</sub>). It is connected to the Baseplate with flat cable and installed side by side to drawer mounting rail with MCU main unit.

Voltage unit detection is done as automatic function by the use of internal code signaling.

**2.3.2 MCU enclosure material**

The enclosure of the MCU is made of polycarbonate with 10 % glassfibre. Flammability rating of the material is UL 94 V-0 and material is halogen free.

Colour of the enclosure is RAL 7012.

Material is recyclable and is shown by the respective marking inside the enclosure parts.

Notes:

### 3 MCU Interfaces

#### 3.1 MCU connectors

##### 3.1.1 Connector designations

MCU1 has 6 and MCU2 has 10 I/O connectors presented in this chapter.

I/O connectors located in the bottom of the unit utilizes the ducts of the mounting rail for cabling, which must be noticed when considering the dimensions of the installation.

**Table 2.** Device connectors.

Connector designation	Connector usage	Connectors	MCU1	MCU2
L1 – T1; L2 – T2; L3 – T3	Current measurement	Lead-through	X	X
X11	Contact control output	X11.1..X11.6	X	X
X12	Fieldbus	X12.1..X12.3	X	X
X13	24 VDC I/O, drawer external	X13.1..X13.34	X	X
X14	24 VDC I/O, drawer internal	X14.1..X14.14	X	X
X15	24 VDC LED output	X15.1..X15.6	X	X
X16	PTC input	X16.1..X16.4		X
X17	Voltage measurement	X17.1..X17.3		X
X18	Auxiliary power supply (U <sub>AUX2</sub> )	X18.1 ..X18.2		X
Voltage unit connector	Voltage unit connection	Voltage unit only		X

**Table 3.** Recommended plugs and cables.

Connector designation	Connector on unit	Recommended... Plug /Contacts	Cable	Remarks
L1 – T1; L2 – T2; L3 – T3	φ 12 mm hole	-	-	
X11	Phoenix MSTBV A2,5/6-G-5,08	Phoenix QC1/6-ST-5,08	-	Cross section 1.0 mm <sup>2</sup>
X12	Phoenix MCV1,5 / 3-GF-3,81	Phoenix MC 1,5/3-STF- 3,81	Unitronic- Bus LD 1x2xx0.22	
X13	AMP 104128-6	AMP 102387-8 (1 pcs) / AMP 167301-4 (single delivery) AMP 141708-1 (reel delivery)	AWG20	Single wires, max. 34 con- tacts
X13		AMP 3-215882 and 3- 100103-4	AWG28	Flat cable
X14	AMP 826469-7	AMP 926476-7 (1 pcs) and AMP 926477-1 (2 pcs) / AMP 167301-4 (single delivery)  AMP 141708-1 (reel delivery)	AWG20	Single wires, max 13 con- tacts
X15	AMP 826469-3	AMP 926476-3 (1 pcs) and AMP 926477-1 (1 pcs) / AMP 167301-4 (single delivery)  AMP 141708-1 (reel delivery)	AWG20	Single wires, max 4 con- tacts

**Notes:**

X16	AMP 215876-6	AMP 5-569031-3	-	
X17	Cable length 700 mm	Free end	H07V2-K	Cross section 2.5 mm <sup>2</sup>
X18	Cable length 400 mm	Free end	H07V-K	Cross section 1.0 mm <sup>2</sup>
Voltage unit connector	-	-	-	VU cable length 200 mm

**Note:** For the INSUM system standard cable sets are provided. They have to be used accordingly.

### 3.1.2 Connector locations

**Picture 3.** Connectors on the bottom of the MCU and the Voltage unit.

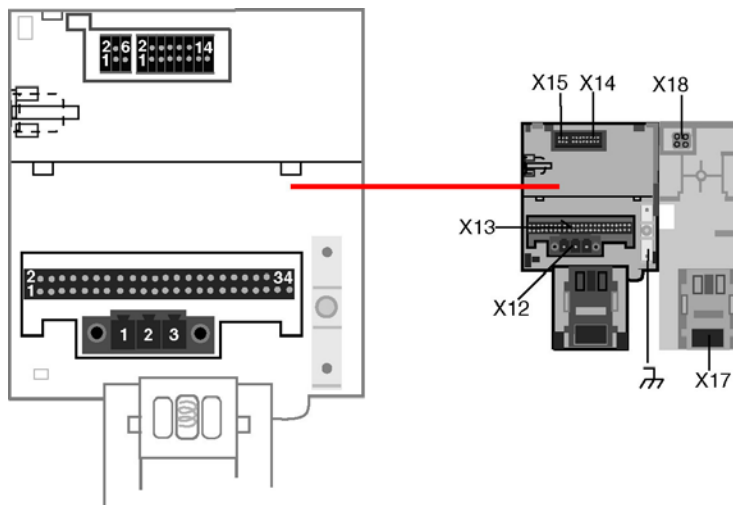

**Picture 4.** Connectors on the side of the unit.

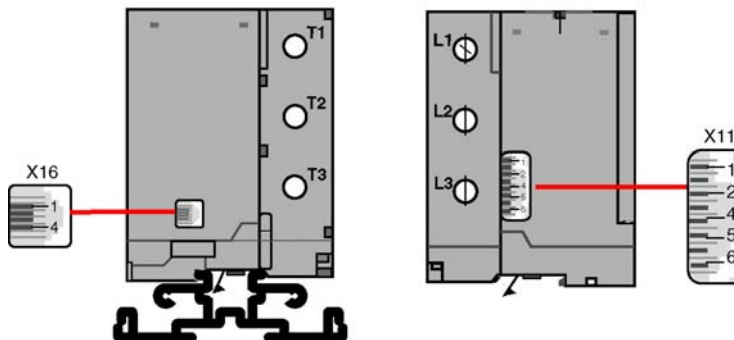

### 3.1.3 Internal/external connector for I/O

Some of the connections are provided for both drawer internal and external use, practically this is an internal cross-connection between connectors X13 and X14. In practice, the difference between connectors are disturbance filtering which is for connector X13 stronger than for connector X14.

Because of that principle user must not use or connect both connectors for one input at the same time and/or cross-connect common wires between connectors.

**Notes:**

**3.2 Power supply**

**3.2.1 Nominal Input Voltage**

MCU utilizes two power supply options. Auxiliary supply voltage 1 (UAUX1) is connected to connector X13. Auxiliary supply voltage 2 (UAUX2) is connected to voltage unit connector X18.

Auxiliary voltages available:

**Table 4.** Auxiliary supply voltage ranges (U<sub>AUX1</sub> and U<sub>AUX2</sub>) and options.

	Voltage range for U <sub>AUX1</sub>	Voltage range for U <sub>AUX2</sub>
MCU1	+19...+33 VDC	*)
MCU2	+19...+33 VDC	**187...250 VAC

\*) Not available

\*\*) Optional and selectable with type designation.

**Table 5.** Auxiliary power supply input connectors and pins.

Conn./Pin	Name	Description
X13:25	U <sub>AUX1</sub> (0 VDC)	U <sub>AUX1</sub> input 0 VDC / Common
X13:26	U <sub>AUX1</sub> (0 VDC)	U <sub>AUX1</sub> input 0 VDC
X13:27	U <sub>AUX1</sub> (+24 VDC)	U <sub>AUX1</sub> input +24 VDC
X13:28	U <sub>AUX1</sub> (+24 VDC)	U <sub>AUX1</sub> input +24 VDC
X18:01	U <sub>AUX2</sub> (L)	U <sub>AUX2</sub> input L (power supply through voltage unit)
X18:02	U <sub>AUX2</sub> (N)	U <sub>AUX2</sub> input N (power supply through voltage unit)

**3.2.2 Power consumption**

MCU power consumption is typically 4.7 W / 33 VDC. Maximum power consumption for MCU1 is 7.2 W / 33 VDC while MCU2 has 8.2 W / 33 VDC. The power taken by the unit is depending for the connection of the unit as well as the supply voltage.

For a certain application, the maximum steady state power consumption can be calculated with following values for both MCU1 and MCU2. Calculation considers the impact of supply voltage by using the worst case situation (33 VDC supply).

**Table 6.** Power consumption calculation (maximum steady state consumption).

Input	Power consumption / one input
Unit (MCU1 or MCU2)	2.5 W
Contact control	0.4 W
LED output	0.8 W
Active input	0.1 W

Thus as an example typical and maximum power consumption are:

Typical  $2,5W + 1 \times 0.4W + 2 \times 0.8W + 2 \times 0.1W = 4.7W$

Maximum (MCU1)  $2,5W + 1 \times 0.4W + 4 \times 0.8W + 11 \times 0.1W = 7.2W$

Maximum (MCU2)  $2,5W + 2 \times 0.4W + 4 \times 0.8W + 17 \times 0.1W = 8.2W$

**Notes:**

**3.3 Digital input**

MCU1 has 12 and MCU2 has 17 digital inputs of the type 10 mA / 24 VDC. Digital input is activated when connected to the corresponding common terminal.

The polarity of the inputs can be selected as Normally Open (NO) or Normally Closed (NC) by parameterization. With polarity selection, the active condition for each input can be set separately. For default polarities and more information see appendix "MCU1 and MCU2 DIGITAL INPUT CONFIGURATION".

As an example the Local input for a unit MCU1A01C01-4 will be activated when terminal X13:16 is connected through switch to terminal X13:25 on the same connector. When input is parameterized as normally open the device is in a local control mode.

Digital input can be found on connectors X13 and X14. Based on the source of input wiring, drawer external or internal, either of connector is chosen.

**Note!**

- When digital input is electrically activated (NC) current consumption is effected accordingly
- Cross-connection between connectors is not allowed.

Digital inputs are cyclically read and 1 kΩ or a smaller resistance between input and common is detected as closed contact. The contact is also detected as closed if the input current is periodically over 2,6 mA and open if current is under 0,8 mA.

**Table 7.** Digital input connectors and pins.

Conn./Pin	Name	Description	MCU1	MCU2
X13:12	START1	Motor start 1 switch input (CW, Open)	X	X
X13:13	START2	Motor start 2 switch input (CCW, Close)	X	X
X13:14	STOP	Motor stop switch input	X	X
X13:15	RESET	Trip reset switch input	X	X
X13:16	LOCAL	Remote/local control switch input	X	X
X13:17	EMSTOP	Auxiliary contact input from emergency stop switch	X	X
X13:18	LIMIT1	Limit position switch 1 input	-	X
X13:19	LIMIT2	Limit position switch 2 input	-	X
X13:20	CFC/ TORQUE	Contact control C feedback input, torque input (actuator)	-	X
X13:32	24VDIGI	Common to drawer external I/O	X	X
X14:01	TEST	Switch disconnecter "Test" input and LON "Service" input	X	X
X14:02	SD	Switch disconnecter 0/1 position input	X	X
X14:03	EXTRIP	External trip input	X	X
X14:04	24VDIGI	Common to drawer internal I/O	X	X
X14:06	MCB	Auxiliary contact from miniature circuit breaker	X	X
X14:07	CFA	Contact control A feedback input	X	X
X14:08	CFB	Contact control B feedback input	X	X
X14:09	CFC	Contact control C feedback input (drawer internal)	-	X
X14:05	24VDIGI	Common to drawer internal I/O	X	X

**Notes:**

**3.4 LED output**

**3.4.1 LED output terminals**

MCU1 and MCU2 have 9 LED outputs with current limit. LED output is connected through external primary resistance to set the LED brightness according to the application. As an example, led output 'READY' in unit MCU2A01V2-4 can be wired from terminal X13:8 through a primary resistor and LED. This circuit is then connected to terminal X13:25 on the same connector. Thus, LED indicates when motor is ready to be started.

LED outputs are on connectors X13 and X15. LED outputs on connector X13 can be wired out from the drawer unit while connector X15 is used in the drawer unit.

**Table 8.** LED output connectors and pins.

Conn./Pin	Name	Indication	MCU1	MCU2
X13:06	RUNS CW	LED output for motor running CW indication	X	X
X13:07	RUNS CCW	LED output for motor running CCW indication	X	X
X13:08	READY	LED output for ready to be started indication	X	X
X13:09	ALARM	LED output for active alarm indication	X	X
X13:10	TRIP	LED output for active trip indication	X	X
X13:11	LOCAL	LED output for Local control indication	X	X
X13:25	0VDC	U <sub>AUX1</sub> input 0 VDC / Common	X	X
X15:03	DFP_RUNS	LED output for running CW/CCW indication	X	X
X15:04	DFP_READY	LED output for ready to be started indication / Wink indication	X	X
X15:05	DFP_TRIP	LED output for active trip indication	X	X
X15:06	0VDC	Common to drawer front panel LED output	X	X

**3.4.2 LED functionality**

During normal operation, one or more LED output is active, when connected. LED indication, table below, informs visually the control and motor status.

**Table 9.** LED output functionality.

Situation	LED								
	Alarm	Trip	Ready	Runs CW	Runs CCW	DFP trip	DFP ready	DFP runs	Local
Main switch off	OFF	<b>ON</b>	OFF	OFF	OFF	<b>ON</b>	OFF	OFF	OFF
Stopped no problem	OFF	OFF	<b>ON</b>	OFF	OFF	OFF	<b>ON</b>	OFF	OFF
Running no problem	OFF	OFF	OFF	<b>ON<sup>1)</sup></b>	<b>ON<sup>1)</sup></b>	OFF	OFF	<b>ON</b>	OFF
Ready alarm	<b>ON</b>	OFF	<b>ON</b>	OFF	OFF	OFF	<b>ON</b>	OFF	OFF
Running alarm	<b>ON</b>	OFF	OFF	<b>ON<sup>1)</sup></b>	<b>ON<sup>1)</sup></b>	OFF	OFF	<b>ON</b>	OFF
Tripped – reset <u>not</u> possible	<b>ON</b>	<b>ON</b>	OFF	OFF	OFF	<b>ON</b>	OFF	OFF	OFF
Tripped – reset possible	OFF	<b>ON</b>	OFF	OFF	OFF	<b>ON</b>	OFF	OFF	OFF
Local control selected <sup>2)</sup>	X	X	X	X	X	X	X	X	<b>ON</b>
Remote control selected <sup>2)</sup>	X	X	X	X	X	X	X	X	OFF

<sup>1)</sup> Either of the two LED is activated at the time according to the rotation direction.

<sup>2)</sup> All other combinations are allowed.

**Notes:**

In addition to previous table, when device is set to 'LOCAL' mode 'LOCAL'-LED is active and it is possible to execute local control commands by the use of push buttons connected to the local digital inputs.

For unit installation or lookup the LONWORKS'wink'-operation in the service/wink -installation is implemented by flashing LEDs 'READY' and 'DFP\_READY'. See chapter 'MCU Installation' in this document.

**3.5 Contactor watchdog signalling output**

In MCU, there is one signalling output relay for indicating the status of the unit's internal watchdog. This relay output is on connector X13. In case fault, the watchdog activates and the relay contacts are closed.

Contactor watchdog signalling output activates also when auxiliary power supply is shut down.

**Table 10.** Contactor watchdog signalling connectors and pins.

Conn./Pin	Name	Indication	MCU1	MCU2
X13:01	CWDAL A	Contactor watchdog signalling output, relay contact 1	X	X
X13:02	CWDAL B	Contactor watchdog signalling output, relay contact 2	X	X

**3.6 Contactor control output**

Three contactor control output on connector X11, table below, are the means to control motor through contactors.

**Table 11.** Contactor control connectors and pins.

Conn./Pin	Name	Description	MCU1	MCU2
X11:01	CCWDLI	Contactor control voltage input with watchdog relay	X	X
X11:02	CCLI	Contactor control voltage input	X	X
X11:04	CCA	Contactor control A	X	X
X11:05	CCB	Contactor control B	X	X
X11:06	CCC	Contactor control C	-	X

MCU supports several motor usages, i.e. motor starter types. The control of the contactor is performed with internal relays (output CCA, CCB and CCC) by the microprocessor. MCU1 utilizes controls with relays CCA and CCB while MCU2 uses relays CCA, CCB, CCC and, for some cases, fourth contactor control through GPO1 output.

The contactor control circuitry includes an additional watchdog relay to switch off the contactor control voltage in a case of microprocessor malfunction (device self-supervision functionality). This functionality can be passed by using the direct connection.

MCU monitors the state of the contactor via digital input (CFA, CFB or CFC). The cyclically polled input information is used by feedback supervision function if enabled. Contactor supervision functionality is explained later in this document.

Internal relays CCA and CCB are hardwire-interlocked to prevent both contactors being closed simultaneously. When the other contactor is controlled closed by the microprocessor, it is thus prevented to control the other during that time.

**Note!** With contactor coil data 230V 50 Hz and coil consumption < 800 VA at closing and 44 VA / 15 W at holding (for example ABB contactor type A185 or EH210), the expected contactor control relay (CC\_) life is approx. 700 000 operations.

**Notes:**

**3.7 General purpose digital input**

MCU2 provides general purpose digital inputs (GPI1 and GPI2) on connector X13 or X14 which can be used to read out the digital state of an external switch. The acquired information is then available to other devices through fieldbus.

**Table 12.** General purpose digital input connectors and pins.

Conn./Pin	Name	Description	MCU1	MCU2
X13:21	GPI1	General purpose input 1 (drawer external)	-	X
X13:22	GPI2	General purpose input 2 (drawer external)	-	X
X13:32	24VDigi	Common to drawer external I/O	-	X
X14:05	24VDIGI	Common to drawer internal I/O	-	X
X14:10	GPI1	General purpose input 1 (drawer internal)	-	X
X14:11	GPI2	General purpose input 2 (drawer internal)	-	X

The changed state is converted to a value according to corresponding parameter. Values can be assigned for both ON and OFF states for external switches.

**Note!** Some starter types (e.g. torque switch) make use of these inputs blocking out the general use.

**3.8 General purpose digital output**

MCU2 provides two signaling relays for external control (GPO1 and GPO2) on connector X13. With these outputs external relay can be driven by commands received from fieldbus.

**Table 13.** General purpose digital output connectors and pins.

Conn./Pin	Name	Description	MCU1	MCU2
X13:3	GPO1	General purpose output relay 1	-	X
X13:4	Common	Common control voltage input	-	X
X13:5	GPO2	General purpose output relay 2	-	X

Control commands can be parameterized by setting ON and OFF value separately, which are then interpreted to the control commands of output relay. Both outputs use the same common terminal.

**Note!** Some starter types make use of output GPO1 thus blocking out the general use.

**3.9 Analog output**

MCU2 provides analog output for connection of analog panel meter. Analog output connection is located on connector X13. With this output the highest of three measured phase currents can be indicated via panel meter. Analog output signal (0 .. 20 mA or 4 .. 20 mA) is the actual measured current in relation to motor nominal current.

**Table 14.** General purpose digital output connectors and pins.

Conn./Pin	Name	Description	MCU1	MCU2
X13:24	ANALOGOUT	Current signalling output	-	X
X13:25	U <sub>AUX1</sub> (0 VDC)	U <sub>AUX1</sub> input 0 VDC / Common	-	X



**Notes:**

**3.10 Rotation monitor**

MCU2 provides input for a digital signal for rotation monitoring (RTM). The connection for RTM is located on connector X13.

The rotation monitoring unit is an external device not provided with MCU.

**Table 15.** Rotation monitor connectors and pins.

Conn./Pin	Name	Description	MCU1	MCU2
X13:23	RTM	Rotation monitor input	-	X
X13:26	0VDC	U <sub>AUX1</sub> input 0 VDC / Common to drawer ext. I/O	-	X
X13:32	24VDIGI	Common to drawer external I/O	-	X

**Picture 5.** Connection of the rotation monitor sensor.

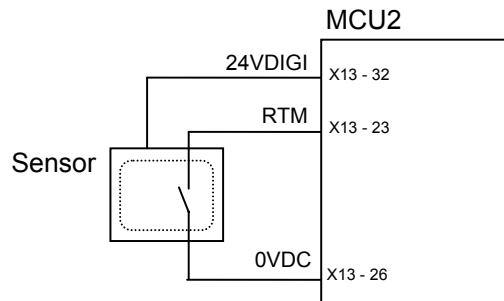

**3.11 PTC input**

MCU2 can utilize PTC sensor(s) to follow the temperature of motor winding. PTC-connector is located on the side of the MCU unit, connector X16.

**Table 16.** PTC input connectors and pins.

Conn./Pin	Name	Description	MCU1	MCU2
X16:02	PTCA	PTC measurement input A	-	X
X16:03	PTCB	PTC measurement input B	-	X

**3.12 Fieldbus interface**

Fieldbus interface on connector X12 uses LonTalk<sup>®</sup> protocol with FTT-10A transceiver. Required bus cabling is shielded twisted pair cable. Connector X12 includes a connection to unit chassis for cable shield through a capacitor (100n) placed inside the unit.

**Table 17.** Fieldbus interface connectors and pins.

Conn./Pin	Name	Description	MCU1	MCU2
X12:01	SGBA	Switchgear bus (LON) line A	X	X
X12:02	SGBB	Switchgear bus (LON) line B	X	X
X12:03	SGB SHIELD	Switchgear bus shield (in-built capacitor)	X	X

If connection to chassis is implemented in several places, elsewhere than MCU unit, it is recommended to place a capacitor in series thus one direct earth connection to chassis is a general recommendation. However, several direct connections to chassis may work better against high frequency interference, but is subject to fault current, if exists. MCU has an in-built capacitor when shield is connected in a following manner.

**Notes:**

**Picture 6.** Fieldbus cable shield and fieldbus connector.

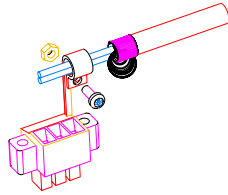

**3.13 Residual current transformer**

MCU2 supports earth fault measurement through Residual Current Transformer (RCT). RCT is connected to the unit through terminals I0A – I0B either in connectors X13 or X14.

Connector X14 is used if sensor is located inside the drawer unit while X13 is used when sensor is located outside from the drawer unit.

**Table 18.** Residual current transformer connectors and pins.

Conn./Pin	Name	Usage	MCU1	MCU2
X13:33	I0A	Residual current transformer input A (drawer external)	-	X
X13:34	I0B	Residual current transformer input B (drawer external)	-	X
X14:13	I0A	Residual current transformer input A (drawer external)	-	X
X14:14	I0B	Residual current transformer input B (drawer external)	-	X

Residual current transformer input is designed to be used with listed transformer types by ABB.

**Table 19.** RCT type information.

Type	Code	Diameter	MCU1	MCU2
Closed	1SDA 037394R0001	60 mm	-	X
Closed	1SDA 037395R0001	110 mm	-	X
Ripped	1SDA 037396R0001	110 mm	-	X
Ripped	1SDA 037397R0001	180 mm	-	X
Ripped	1SDA 037398R0001	230 mm	-	X

Burden resistors must be installed with RCT according to transformer manufacturer's instructions.

**Table 20.** Burden resistor values with residual current transformer.

Measurement range / A	Burden resistor / Ω
0.1 – 1.0	330
>1.0 – 5.0	68
>5.0 – 50.0	7.5

The power rating of the burden resistors should be 0.5 W and tolerance 1 % (max).

**Note!** Accuracy of burden resistor reflects directly to the accuracy of earth current measurement.

**3.14 Motor phase currents**

**3.14.1 Current measurement terminals**

MCU1 and MCU2 measure continuously three motor phase currents. The phase current data, after being converted from analog to digital, will be used by the protection functions and is reported to the fieldbus. Values from the measured phases are reported as both absolute ampere value and relative value, as well. Relative value is proportional to the motor nominal current given by motor nominal current ( $I_n$ ) parameter.

**Notes:**

MCU contains current measurement terminals with three internal current sensors for transforming motor phase currents to the appropriate level for the current sensing electronics. Two physical terminal units with different current measurement range are used upon order information.

Current measurement is based on the value of motor nominal current parameter ( $I_n$ ) which is selectable according to range of current measurement terminals. Motor nominal current parameter ( $I_n$ ) determines the internal current range selection for microprocessor and electronics. Measurement range, accuracy and reported relative current values are thus related to the nominal current setting. Practically, the current measurement covers range from 15% of  $I_n$  to  $10 \times I_n$  while the minimum reported current and zero current detection is 5 % of  $I_n$ .

**Table 21.** Current measurement and internal current ranges.

Current measurement Unit $I_n$ range / A	Internal $I_n$ range / A				
	1	2	3	4	5
0.1 – 3.2	$0.1 \leq I_n \leq 0.2$	$0.2 < I_n \leq 0.4$	$0.4 < I_n \leq 0.8$	$0.8 < I_n \leq 1.6$	$1.6 < I_n \leq 3.2$
2-63	2-4	4-8	8-16	16-32	32-63

The unit takes samples from the current at 910 Hz rate for the TRMS value, which is calculated after every 91 samples and updated for further calculations in 100 ms cycle. The reporting rate and the deadband for the reported value can be parameterized.

Current wires are lead through current sensors from either side of the terminals. Direction can be either L - > T or T -> L considering that all currents must have the same direction.

**Note!** When one phase system is selected current is measured only from phase 1.

**3.14.2 Intermediate current measurement**

Motor nominal currents above 63 A are not measured directly, but instead intermediate current transformer's secondary side is connected through MCU current measurement terminal.

The recommended intermediate transformers are presented in the table below and transformation ratio is given with parameters.

**Table 22.** Recommended intermediate transformer's type and code.

CT type	$I_n$ range (A)	ILA-code
KORC1A105/1S	60 – 140	1SCA022387R7660
KORC1A185/1S	105 – 260	1SCA022387R7740
KORC1A310/1S	180 – 430	1SCA022387R7820
KORC3B630/5S	380 – 880	1SCA022126R5210

**3.15 Voltage measurement**

**3.15.1 Voltage measurement connector**

MCU2 continuously measure three phase voltages via Voltage Unit connected to connector X17. The voltage data will be used for protection functions and power factor calculation (cosphi). Voltage data is also reported to the fieldbus as absolute value for measured phases.

**Table 23.** Voltage measurement connectors and pins.

Conn./Pin	Name	Usage	MCU1	MCU2 <sup>1)</sup>
X17:01	MVML1	Motor phase L1 voltage input	-	X
X17:02	MVML2	Motor phase L2 voltage input	-	X
X17:03	MVML3	Motor phase L3 voltage input	-	X

<sup>1)</sup>with Voltage Unit

**Notes:**

**3.15.2 Power factor calculation**

MCU2 has power factor calculation function from the current and voltage input from phase L1. Power factor is calculated from the measured samples at every 100 ms.

The calculated power factor is used in the further calculation of motor power consumption and is reported to the fieldbus. The valid range varies between  $-1...1$ , where negative value indicates capacitive load. Power factor and calculated power values are reported to the fieldbus according to reporting rate defined by parameter or fixed deadband (5 % of previous reported value).

Notes:

## 4 MCU functionality

### 4.1 Starter types

#### 4.1.1 MCU starter types

The motor control unit supports starter types according to the following table. Supported starter types are marked against corresponding variation.

**Table 24.** Starter types for MCU1 and MCU2.

Starter type	Contactor		Note	Command (local/bus)	MCU1	MCU2
	Control	Function				
NR-DOL	CCA	Main contactor		Start/Stop	X	X
REV-DOL	CCA	Main contactor (CW)		Start CW/Stop	X	X
	CCB	Main contactor (CCW)		Start CCW/Stop		
NR-DOL/ RCU	CCA	Main contactor		Start	X	X
	CCB	Stop contactor	MCU1	Stop		
	CCC	Stop contactor	MCU2	Stop		
REV-DOL/ RCU	CCA	Main contactor (CW)		Start CW		X
	CCB	Main contactor (CCW)		Start CCW		
	CCC	Stop contactor		Stop		
NR-DOL/ Latched	CCA	Main contactor		Start		X
	CCC	Stop contactor		Stop		
REV-DOL/ Latched	CCA	Main contactor (CW)		Start CW		X
	CCB	Main contactor (CCW)		Start CCW		
	CCC	Stop contactor		Stop		
NR-SD	CCA	Delta contactor				X
	CCB	Star contactor				
	CCC	Main contactor		Start/Stop		
REV-SD	CCA	Delta contactor				X
	CCB	Star contactor				
	CCC	Main contactor		Start/Stop		
	GPO1	Direction (CW/CCW)				
NR-2N	CCA	Main contactor (N1)		Start N1/ Stop		X
	CCB	Star contactor (N2)				
	CCC	Main contactor (N2)		Start N2/ Stop		
REV-2N	CCA	Main contactor (N1)		Start N1/ Stop		X
	CCB	Star contactor (N2)				
	CCC	Main contactor (N2)		Start N2/ Stop		
	GPO1	Direction (CW/CCW)				
Actuator	CCA	Main contactor (Open)	Torque opt.	Open/Stop		X
	CCB	Main contactor (Close)	Torque opt.	Close/Stop		
Autotrafo	CCA	Star contactor				X
	CCB	Main contactor		Start/Stop		
	CCC	Transformer contactor				

**Notes:**

Principle pictures for contactor control connections for each starter type is presented in appendix section. Feedback supervision (CFx) functionality is explained in chapter "Feedback supervision".

Single phase softstarters are not defined as starter types but are handled with parameters.

**Note!** It is recommended to use watchdog in the control circuit for all starter types.

**4.1.2 Parameters**

Starter type is selected by the user with a dedicated parameter to match the wiring for contactor and motor control circuits. Feedback supervision functionality can be selected with parameter and requires corresponding wiring from each contactor.

Some of the starter types provide more parameters that are listed with corresponding starter. Parameters provided by protection functions are listed in chapter "Protection Functions".

Further information on parametering can be obtained from the document INSUM MCU Parameter Description.

**4.1.3 Starter types requiring feedback supervision**

Feedback supervision function is available via parameterization for all starter types and when enabled must be wired accordingly. For more information see chapter "Feedback supervision".

**Note!**

- It is highly recommended that feedback supervision is enabled with all starter types.
- NR-DOL/RCU and REV-DOL/RCU starter types **require** feedback supervision functionality and contactor feedback signals (CFA, CFB and CFC) must be wired.

**4.1.4 NR-DOL starter**

NR-DOL starter is the basic starter type for driving motor to one direction. When start command has been received from fieldbus or local I/O the contactor control output will be energized and remains this condition until stop command has been received or any protection function is activated.

**Table 25.** NR-DOL starter contactor control interface.

Name	Pin	Description
CCWDLI	X11:01	Contactor control voltage input with watchdog relay
CCLI	X11:02	Contactor control voltage input
CCA	X11:04	Contactor control A
CFA	X14:07	Contactor control A feedback input
LOCAL	X13:16	Remote/local control switch input
START1	X13:12	Motor start 1 switch input (CW, Open)
STOP	X13:14	Motor stop switch input

The control of this starter type is done either from push buttons connected to unit I/O or via fieldbus interface.

**Notes:**

**Picture 7.** Contactor control wiring for NR-DOL starter, MCU1 and MCU2.

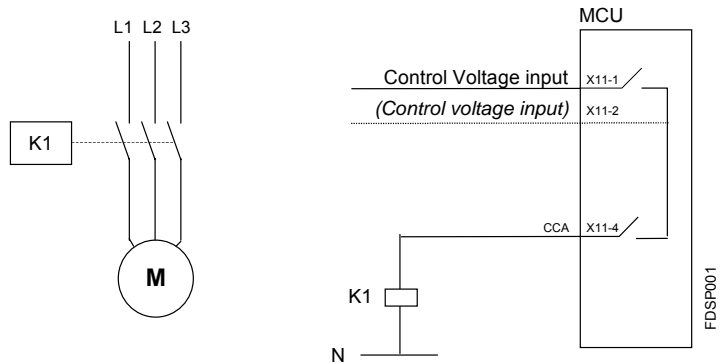

**Note!**

- Single phase motor starter is possible only with NR-DOL starter type
- Solenoid applications can be implemented with NR-DOL configuration.

**4.1.5 REV-DOL starter**

REV-DOL uses contactor control output A signal for controlling the contactor, which drives motor to direction CW, and correspondingly contactor control output B is used for direction CCW. When starting motor to either direction contactor will be energized and is stopped (de-energized) by command (fieldbus or local I/O) or active protection function.

**Picture 8.** Contactor control wiring for REV-DOL starter, MCU1 and MCU2.

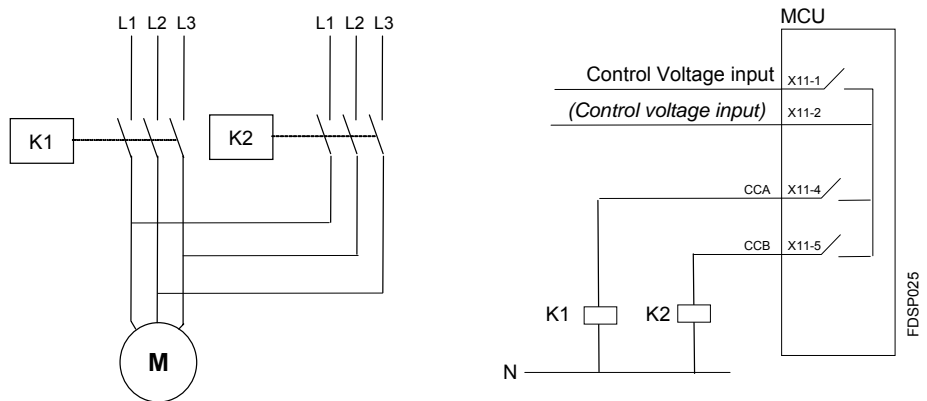

**Table 26.** REV-DOL starter contactor control interface.

Name	Pin	Description
CCWDLI	X11.01	Contactor control voltage input with watchdog relay
CCLI	X11:02	Contactor control voltage input
CCA	X11:04	Contactor control A
CFA	X14:07	Contactor control A feedback input
CCB	X11:05	Contactor control B
CFB	X14:08	Contactor control B feedback input
LOCAL	X13:16	Remote/local control switch input
START1	X13:12	Motor start 1 switch input (CW, Open)
START2	X13:13	Motor start 2 switch input (CCW, Close)
STOP	X13:14	Motor stop switch input

**Notes:**

REV-DOL starter has a built in logic for accepting reversing controls. Start sequence, when changing motor direction, can be as follows:

START1 - STOP - START2  
 START2 - STOP - START1

**Note!** Motor supply must be wired to match the right rotation direction (CW/CCW).

**4.1.6 NR-DOL and REV-DOL starter with latched option**

Direct on line starters (NR-DOL or REV-DOL) with latched option is supported by MCU2. Functionality is based on pulse operated contactor control outputs.

**Table 27.** Latched contactor control interface.

Name	Pin	Description
CCWDLI	X11:01	Contactor control voltage input with watchdog relay
CCLI	X11:02	Contactor control voltage input
CCA	X11:04	Contactor control A
CFA	X14:07	Contactor control A feedback input
CCB	X11:05	Contactor control B
CFB	X14:08	Contactor control B feedback input
CCC	X11:06	Contactor control C
CFC	X14:09	Contactor control C feedback input (drawer internal)
	X13:20	Contactor control C feedback input (drawer internal)
LOCAL	X13:16	Remote/local control switch input
START1	X13:12	Motor start 1 switch input (CW, Open)
START2	X13:13	Motor start 2 switch input (CCW, Close)
STOP	X13:14	Motor stop switch input

**Picture 9.** Control circuit for latched NR-DOL with normal contactors, MCU2.

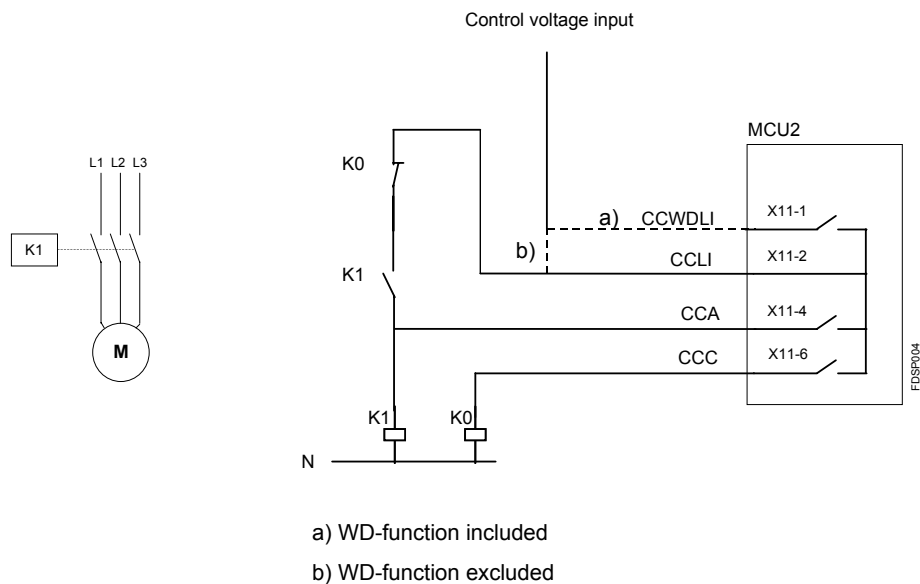



**Notes:**

**Picture 10.** Control circuit for latched REV-DOL with normal contactors, MCU2.

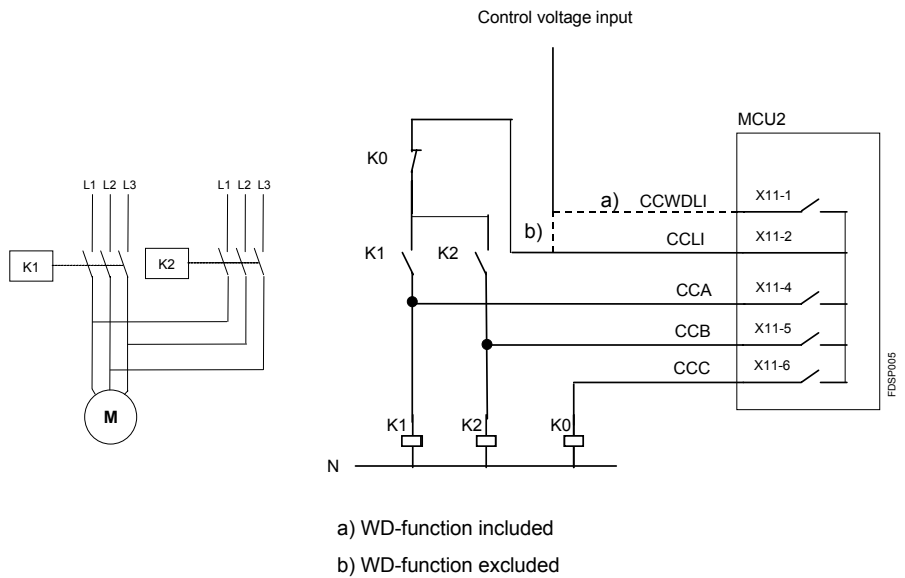

**Picture 11.** Control circuit for latched NR-DOL, mechanical latched contactor.

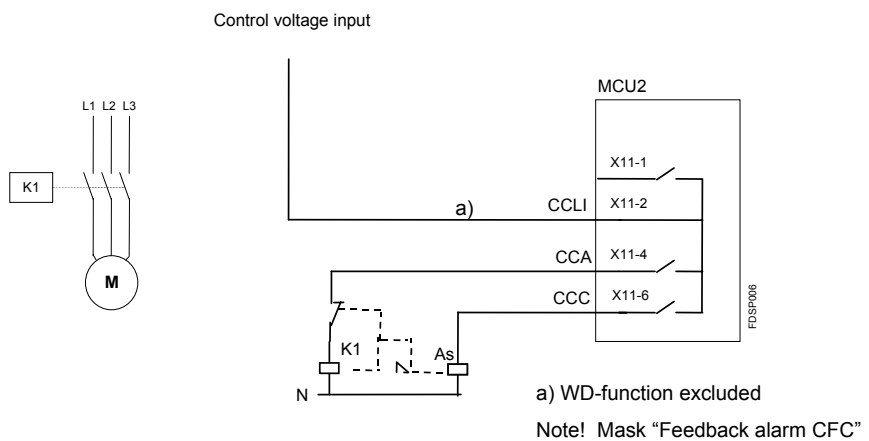

**Picture 12.** Control circuit for latched NR-DOL, magnetic latched contactor.

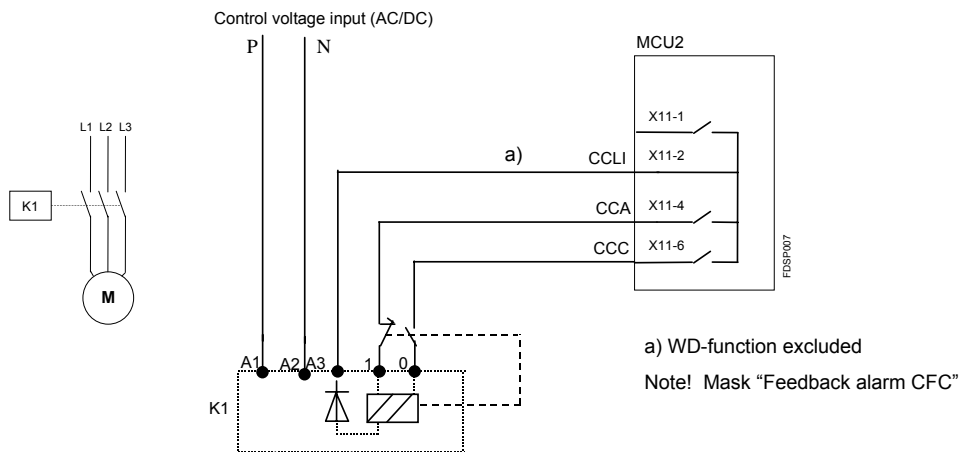

Latched contactor is parameterized separately and is available with starter types NR-DOL and REV-DOL.

**Notes:**

**4.1.7 NR-DOL and REV-DOL for softstarter applications**

Softstarter applications are for controlling motor accessory softstarter device. MCU2 gives start and stop commands to the softstarter unit which is set for adjusting motor voltage with its own parameters. More information about softstarter can be found in softstarter manufacturer manual.

All protection functions are supported by this starter type during normal "Running" situation. For motor start and stop period some of the protection functions are disabled by these parameters, for more information see chapter "Protection functions disabled".

**Picture 13.** Control circuit with softstarter for NR-DOL, MCU2.

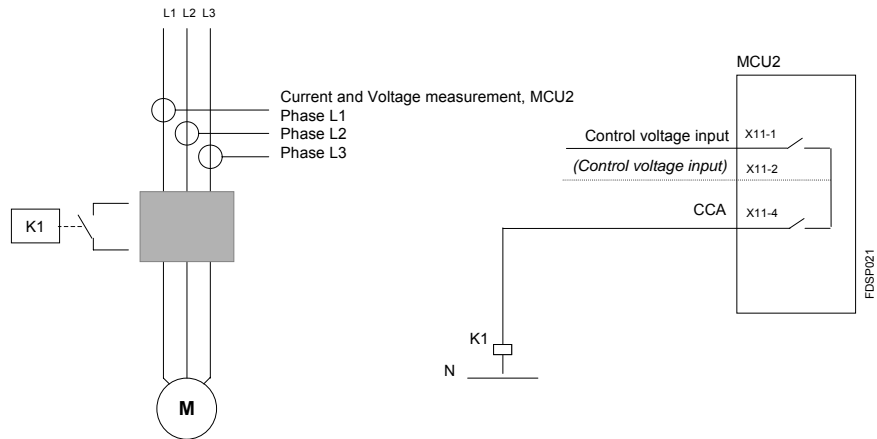

For applications utilizing two rotation directions also, two softstarter units are needed.

**Picture 14.** Control circuit with softstarter for REV-DOL, MCU2.

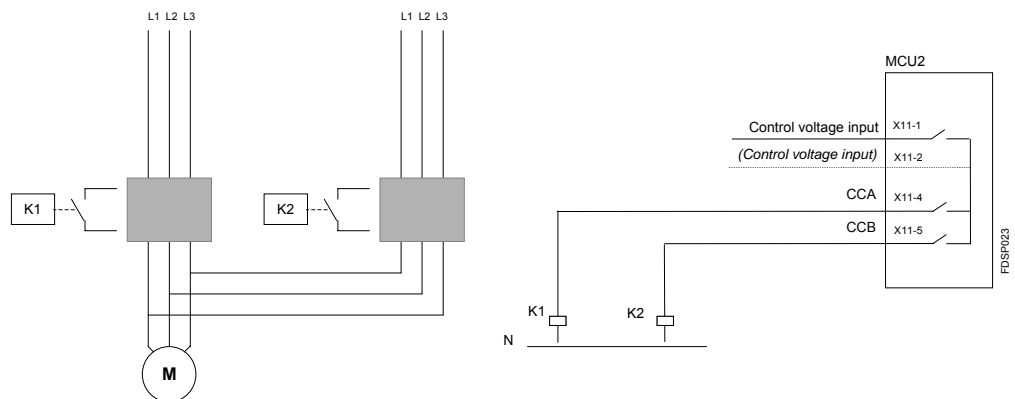

**Notes:**

Application for softstarter with latched contactors:

**Picture 15.** Control circuit with softstarter for NR-DOL, latched contactors.

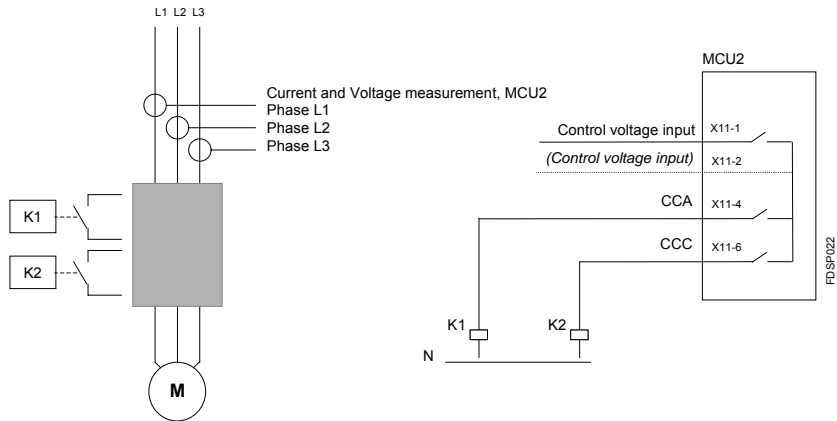

**Picture 16.** Control circuit with softstarter for REV-DOL, latched contactors.

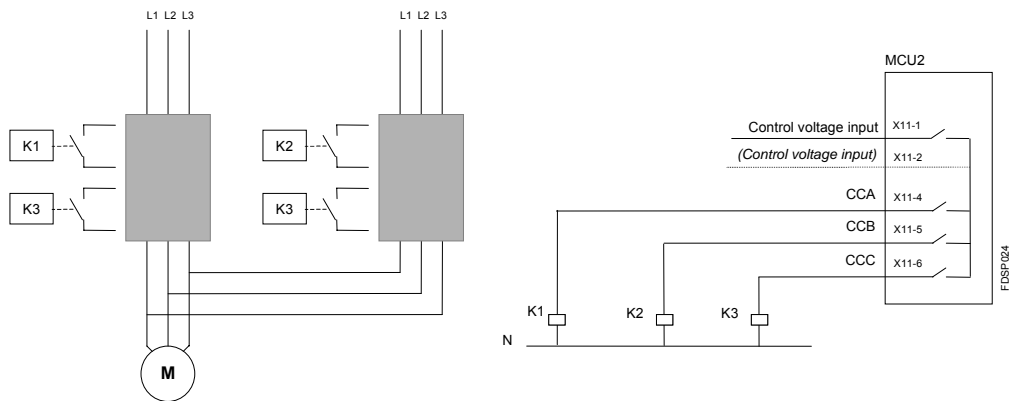

Softstarter is controlled by MCU connected to motor main circuit (current and voltage measurement) before softstarter unit and motor. Control circuit with measurement connection principle is presented in the appendix section of this document. Control circuit is implemented by using contactor controls according to either of starter type NR-DOL or REV-DOL. Depending on the type of softstarter unit latched or normal contactor control can be used to create the triggering (start/stop) command to the unit.

Support for softstarter application is done with specific parameters. For softstarter control following parameters are defined according to application:

**Table 28.** Softstarter parameters.

Parameter	Explanation	Condition
A <i>Softstart ramp time</i>	Start time for the process	Equal to softstarter parameter
B <i>Softstop ramp time</i>	Stop time for the process	Equal to softstarter parameter
C <i>Motor startup time</i>	The time that defined protections are disabled	< Softstart ramp time

**Notes:**

**Picture 17.** Start sequences for softstarter with delay times.

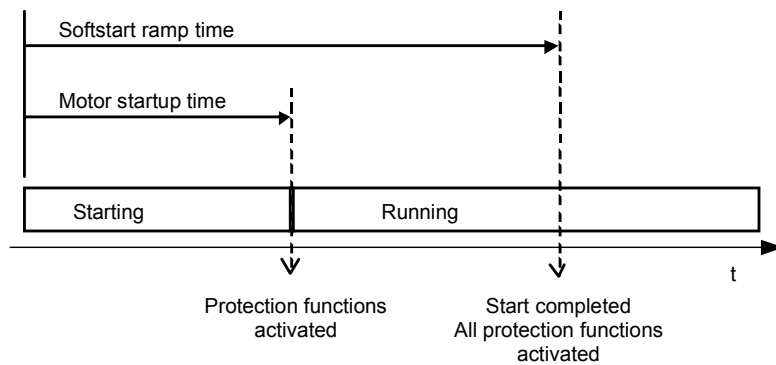

Softstop ramp time defines the time after which measured current must be zero. It is activated from motor stop command. If current is still measured i.e. motor is running the following applies:

- Alarm "Motor still running" is issued and relay CCWDLI (X11:4) is released

**Picture 18.** Stop sequences for softstarter with delay times.

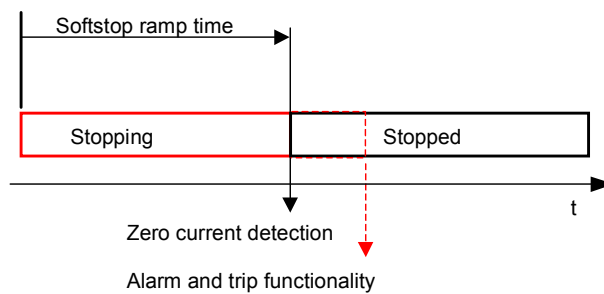

**4.1.8 NR-DOL/RCU starter**

RCU (Remote Control Unit) is a starter type where contactors are directly controlled by a special RCU-switch located near the motor. Starter is supported by both MCU variations. NR-DOL/RCU allows, if designed in such manner, motor to be controlled by RCU-switch even if the MCU is not operational.

**Table 29.** NR-DOL/RCU starter contactor control interface.

Name	Pin	Description
CCWDLI	X11:01	Contactors control voltage input with watchdog relay
CCLI	X11:02	Contactors control voltage input
CCA	X11:03	Contactors control A
CFA	X14:07	Contactors control A feedback input
CCB	X11:05	Contactors control B
CFB	X14:08	Contactors control B feedback input
CCC	X11:06	Contactors control C
CFC	X14:09	Contactors control C feedback input (drawer internal)
	X13:20	Contactors control C feedback input (drawer external)
LOCAL	X13:16	Remote/local control switch input
START1	X13:12	Motor start 1 switch input (CW, Open)
STOP	X13:14	Motor stop switch input

**Notes:**

**Picture 19.** Control circuit for NR-DOL/RCU starter for MCU1.

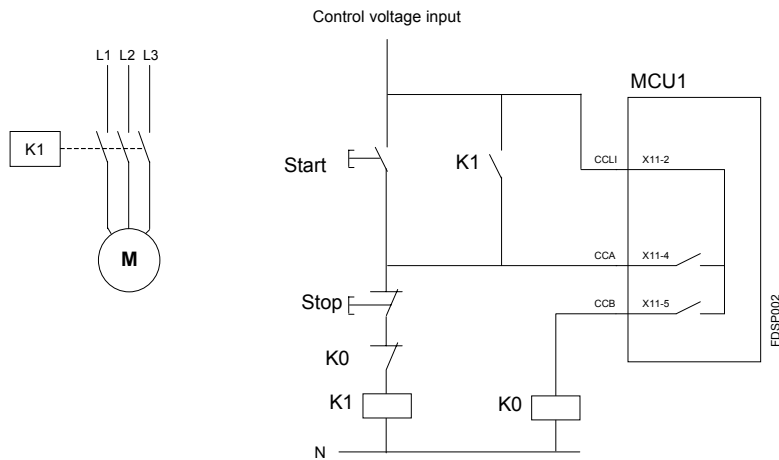

**Picture 20.** Control circuit for NR-DOL/RCU starter for MCU2.

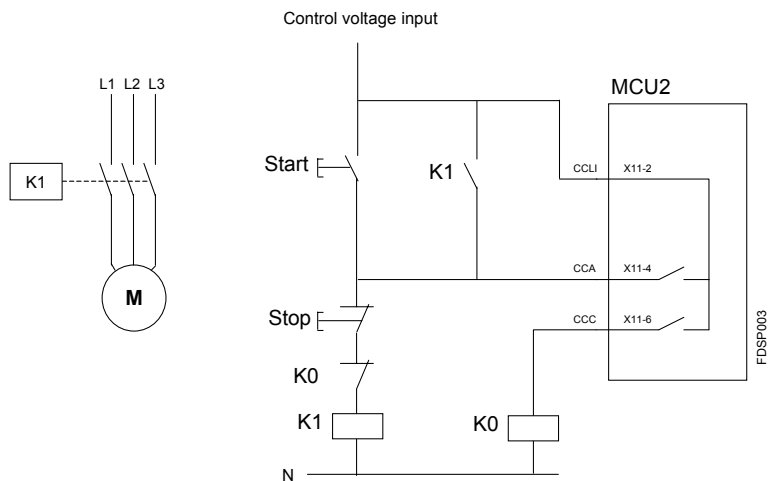

RCU-switch can be e.g. mom-off-mom type switch ('mom' stand for 'momentary on' with spring returning the switch to off position). On the other hand, RCU connection can also be done with normal switches as presented in example circuit on appendix section.

In the NR-DOL/RCU starter MCU1 starts and stops the motor by pulses of contactor controls A and B. Contactors must be latched by wiring of the contactor auxiliary contacts. MCU2 uses contactor controls A and C accordingly.

When motor is being started or stopped by the RCU-switch, MCU issues corresponding events "Motor started CW by RCU-switch" and "Motor stopped by RCU-switch".

Feedback supervision has special functionality when RCU starter has been selected. This functionality is explained in the chapter "Feedback supervision".

**Note!** When starter types NR DOL/RCU or REV DOL/RCU are used, Undervoltage/Trip delay shall be set to zero (0).

**Notes:**

### 4.1.9 REV-DOL/RCU starter

REV-DOL/RCU starter is supported by MCU2. Functionality of this starter type is according to NR-DOL/RCU starter with support for reversing use of motor.

**Table 30.** REV-DOL/RCU starter contactor control interface.

Name	Terminal	Description
CCWDLI	X11:01	Contactorm control voltage input with watchdog relay
CCLI	X11:02	Contactorm control voltage input
CCA	X11:04	Contactorm control A
CFA	X14:07	Contactorm control A feedback input
CCB	X11:05	Contactorm control B
CFB	X14:08	Contactorm control B feedback input
CCC	X11:06	Contactorm control C
CFC	X14:09	Contactorm control C feedback input (drawer internal)
	X13:20	Contactorm control C feedback input (drawer external)
LOCAL	X13:16	Remote/local control switch input
START1	X13:12	Motor start 1 switch input (CW, Open)
START2	X13:13	Motor start 2 switch input (CCW, Close)
STOP	X13:14	Motor stop switch input

When motor is started or stopped by RCU switch MCU issues corresponding events "Motor started CW by RCU-switch" or "Motor started CCW by RCU-switch" and "Motor stopped by RCU-switch".

**Note!** When starter types NR-DOL/RCU or REV-DOL/RCU are used, Undervoltage/Trip delay shall be set to zero (0).

**Picture 21.** Control circuit for REV-DOL/RCU starter, MCU2.

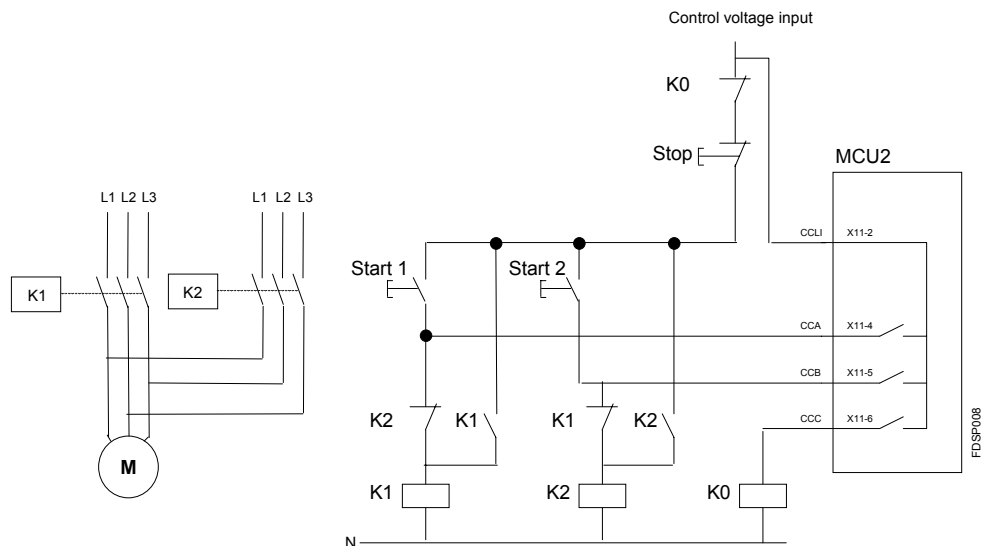

**Notes:**

### 4.1.10 NR-S/D starter

NR-S/D starter is supported by MCU2. Motor start current is reduced in star connection to 1/3 of the current in delta connection, with lower torque during the same time.

**Table 31.** NR-S/D starter contactor control interface.

Name	Pin	Description
CCWDLI	X11:01	Contactor control voltage input with watchdog relay
CCLI	X11:02	Contactor control voltage input
CCA	X11:04	Contactor control A
CFA	X14:07	Contactor control A feedback input
CCB	X11:05	Contactor control B
CFB	X14:08	Contactor control B feedback input
CCC	X11:06	Contactor control C
CFC	X14:09	Contactor control C feedback input (drawer internal)
	X13:20	Contactor control C feedback input, torque input (actuator)
LOCAL	X13:16	Remote/local control switch input
START1	X13:12	Motor start 1 switch input (CW, Open)
STOP	X13:14	Motor stop switch input

**Picture 22.** Control circuit for NR-S/D starter, MCU2.

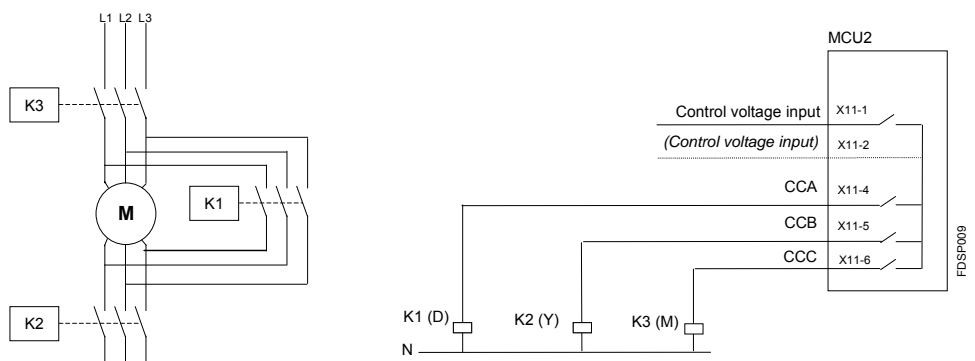

NR-S/D starter utilizes additionally following parameters:

- Motor startup time
- S/D changeover basis
- S/D changeover current

Star to delta starting sequence is based on the presented control logic picture. There are two conditions available to select the condition to change from star to delta connection. Available changeover conditions are as follows:

- Current
- Time

**Table 32.** Parameters for selecting change over condition.

Parameter	Value	Parameter / value
S/D change over basis	Time	Motor startup time
	Current	S/D change over current

**Notes:**

When current is selected as a changeover basis the current limit is set with a dedicated parameter (1 S/D changeover current), see picture below. During motor start in star connection the measured current must come below this current limit and remain more than 1 sec before change to delta connection is executed. If current does not fulfil this condition before defined limit (2 parameter Motor startup time) motor will be tripped and alarm message "Stall trip".

When Time is selected as a changeover basis parameterized time (Motor startup time) is used as a star connection time after which changeover to delta connection is done.

**Picture 23.** NR-S/D switching over parameters, principle picture.

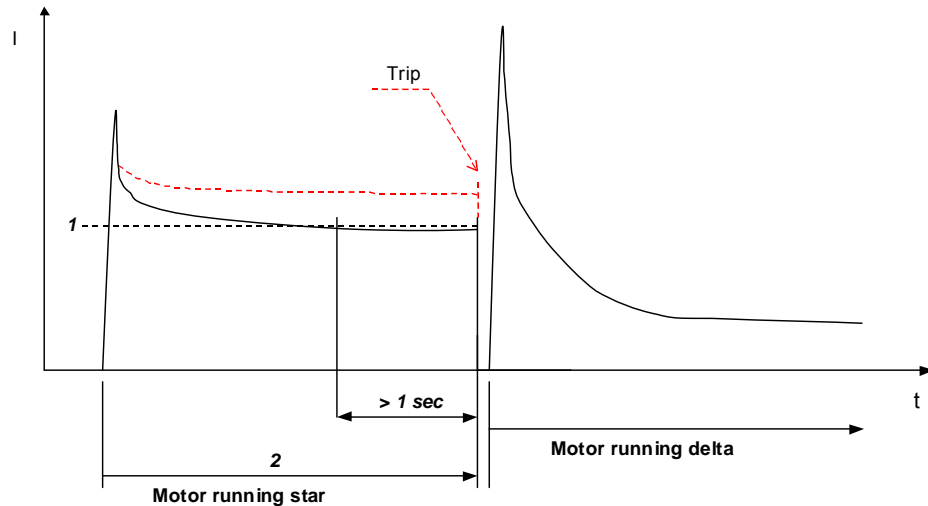

The MCU2 control contactors with sequence presented in the control logic picture. For all contactor conditions the previous condition must be fulfilled before a new control is executed (feedback supervision enabled). If feedback supervision activates a trip, the start will be cancelled accordingly.

**Note!** It is recommended to use feedback supervision always with NR-S/D starter.

NR-S/D is normally controlled with three contactors, as connection example presented in control circuit for NR-S/D starter, but MCU provides a possibility to implement star/delta starter with two contactors by using contactor control CCA and CCB. Recommended implementation for two contactor application is by simulating the third contactor feedback with an auxiliary relay connected to contactor control output CCC. In case of other implementations, a possible feedback alarm from unused feedback input (CFc) could be discarded by the external control system.

**4.1.11 REV-S/D starter**

Reversing star/delta starter, REV-S/D, uses four contactor control outputs for motor control. The functionality is according to NR-S/D except there is one contactor more for reversing control. Fourth contactor is implemented by using GPO1 and feedback information is achieved via input GPI1 and GPI2.



**Notes:**

**Table 33.** REV-S/D starter contactor control interface.

Name	Pin	Description
CCWDLI	X11:01	Contactor control voltage input with watchdog relay
CCLI	X11:02	Contactor control voltage input
CCA	X11:04	Contactor control A
CFA	X14:07	Contactor control A feedback input
CCB	X11:05	Contactor control B
CFB	X14:08	Contactor control B feedback input
CCC	X11:06	Contactor control C
CFC	X14:09	Contactor control C feedback input (drawer internal)
	X13:20	Contactor control C feedback input (drawer external)
GPO1	X13:03	General purpose output relay 1
GPI1	X13:21	General purpose input 1 (drawer external)
	X14:10	General purpose input 1 (drawer internal)
GPI2	X13:22	General purpose input 2 (drawer external)
	X14:11	General purpose input 2 (drawer internal)
LOCAL	X13:16	Remote/local control switch input
START1	X13:12	Motor start 1 switch input (CW, Open)
START2	X13:13	Motor start 2 switch input (CCW, Close)
STOP	X13:14	Motor stop switch input

User can control starter (start and stop command) like in NR-S/D starter type. Motor will be stopped either locally by activated stop input or remotely via fieldbus or by an activated protection function.

Following sequences are allowed:

- Start CW / Stop
- Start CCW / Stop
- Start CW / Stop / Start CCW
- Start CCW / Stop / Start CW

**Picture 24.** Control circuit for REV-S/D starter, MCU2.

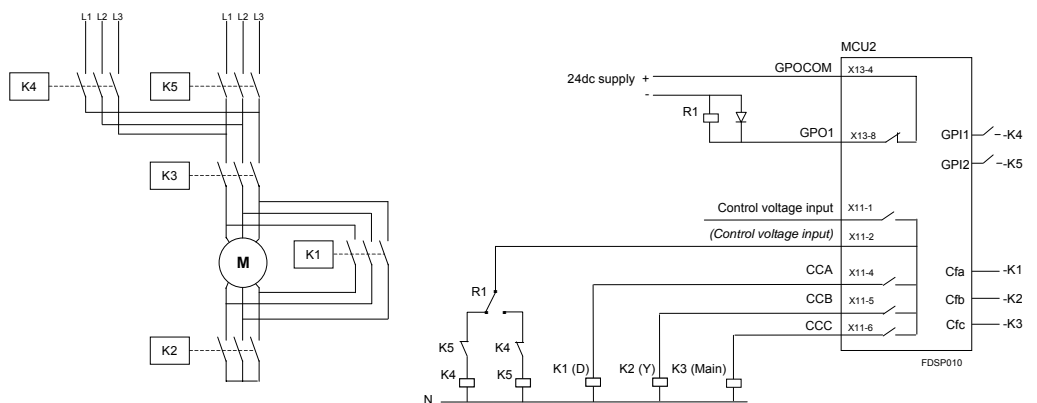

**Notes:**

### 4.1.12 NR-2N starter

Two speed non-reversing starter (NR-2N) is supported by MCU2. NR-2N uses three contactor controls to control motor rotation speed. Rotation speed can be changed "on the fly" without stop command in between.

**Table 34.** NR-2N starter contactor control interface.

Name	Pin	Description
CCWDLI	X11:01	Contactor control voltage input with watchdog relay
CCLI	X11:02	Contactor control voltage input
CCA	X11:04	Contactor control A
CFA	X14:07	Contactor control A feedback input
CCB	X11:05	Contactor control B
CFB	X14:08	Contactor control B feedback input
CCC	X11:06	Contactor control C
CFC	X14:09	Contactor control C feedback input (drawer internal)
	X13:20	Contactor control C feedback input (drawer external)
LOCAL	X13:16	Remote/local control switch input
START1	X13:12	Motor start 1 switch input (CW, Open)
STOP	X13:14	Motor stop switch input

**Picture 25.** Control circuit for NR-2N starter, Dahlander, MCU2.

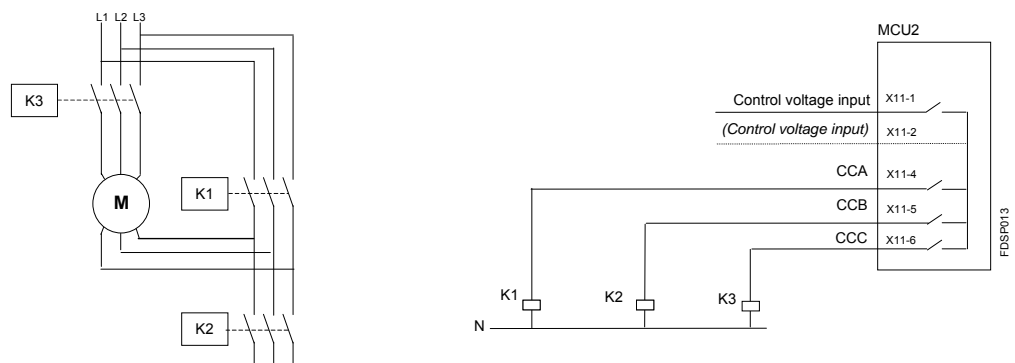

**Picture 26.** Control circuit for NR-2N with two contactors, separate windings, MCU2.

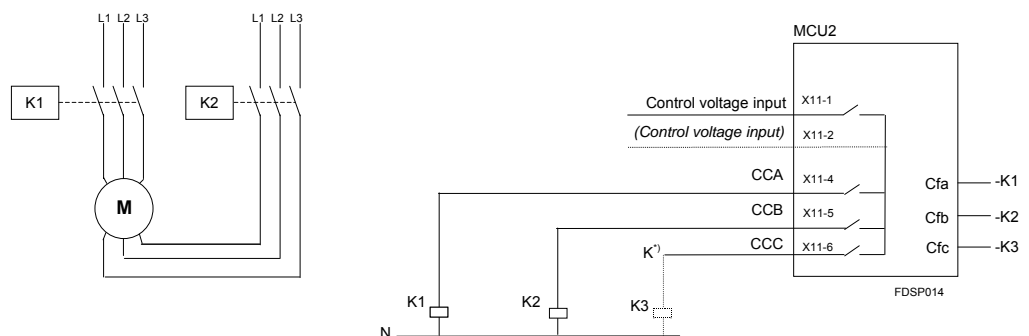

K') Feedback signal Cfc must be connected for feedback supervision.  
 Recommended connection is to use a relay to simulate missing contactor.  
 Optionally feedback can be connected in parallel from contactor -K2 (not recommended).

NR-2N starter is designed for three contactor control (Dahlander). However, it can be wired for two contactor control (separate winding), see picture above.

### Notes:

Current measurement for NR-2N utilizes two external current transformers measuring current from motor mains supply. External current transformers can be selected separately for both motor windings. More information about the parametering can be obtained from the document INSUM MCU Parameter Description.

**Picture 27.** External current transformer connection for NR-2N to MCU2 unit.

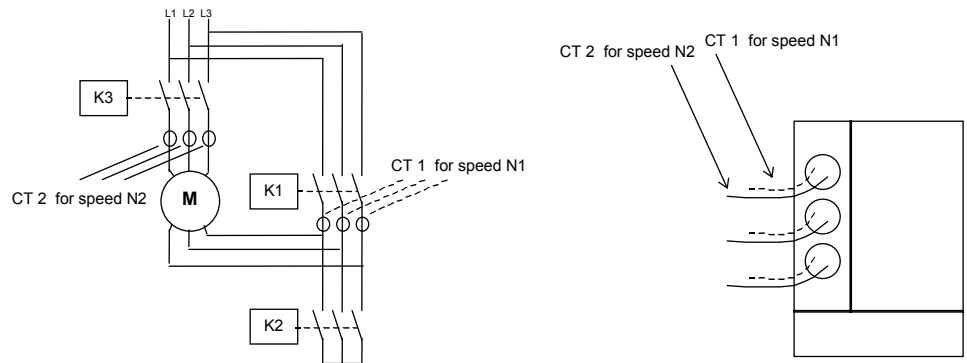

**Note!** Running information is indicated locally by LED outputs only for motor running to either direction (CW or CCW), i.e. motor speeds are not indicated locally.

Motor can be controlled with sequences e.g.:

- Stop -> Speed N1 -> Stop
- Stop -> Speed N2 -> Stop
- Stop -> Speed N1 -> Speed N2 -> Stop
- Stop -> Speed N2 -> Speed N1 -> Stop
- Stop -> Speed N1 -> Speed N2 -> Speed N1 -> Stop
- Stop -> Speed N2 -> Speed N1 -> Speed N2 -> Stop

**Notes:**

**4.1.13 REV-2N starter**

REV-2N is supported by MCU2. Control circuit is implemented by using following contacts.

**Table 35.** REV-2N starter contactor control interface.

Name	Pin	Description
CCWDLI	X11:01	Contactor control voltage input with watchdog relay
CCLI	X11:02	Contactor control voltage input
CCA	X11:04	Contactor control A
CFA	X14:07	Contactor control A feedback input
CCB	X11:05	Contactor control B
CFB	X14:08	Contactor control B feedback input
CCC	X11:06	Contactor control C
CFC	X14:09	Contactor control C feedback input (drawer internal)
	X13:20	Contactor control C feedback input (drawer external)
GPO1	X13:03	General purpose output relay 1
GPI1	X13:21	General purpose input 1 (drawer external)
	X14:10	General purpose input 1 (drawer internal)
GPI2	X13:22	General purpose input 2 (drawer external)
	X14:11	General purpose input 2 (drawer internal)
START1	X13:12	Motor start 1 switch input (CW, Open)
START2	X13:13	Motor start 2 switch input (CCW, Close)
STOP	X13:14	Motor stop switch input
LIMIT1	X13:18	Limit position switch 1 input
LIMIT2	X13:19	Limit position switch 2 input

GPO1 is used for controlling rotation direction via two contactors. GPI1 and GPI2 are used for reading the status of these contactors. Contactor control is done via one switching type of relay, which selects always one of the contactor (direction), also when motor is not running.

User can control motor both by using switches connected to MCU2 I/O or send commands through fieldbus. In addition to normal start and stop switches, also MCU2 limit switch inputs are used by this starter type for selection of the rotation direction.

From local I/O user can give following commands:

- Start CW-N1 with start switch input START1
- Start CW-N2 with limit switch input LIMIT1
- Stop
- Start CCW-N1 with start switch input START2
- Start CCW-N2 with limit switch input LIMIT2.

Via fieldbus interface all commands can be executed:

- Start CW-N1
- Start CW-N2
- Stop
- Start CCW-N1
- Start CCW-N2

Speed can be changed without a stop in between. Change of rotation direction is allowed only after stop command.

**Notes:**

**Picture 28.** Control circuit for REV-2N starter, reversing Dahlander.

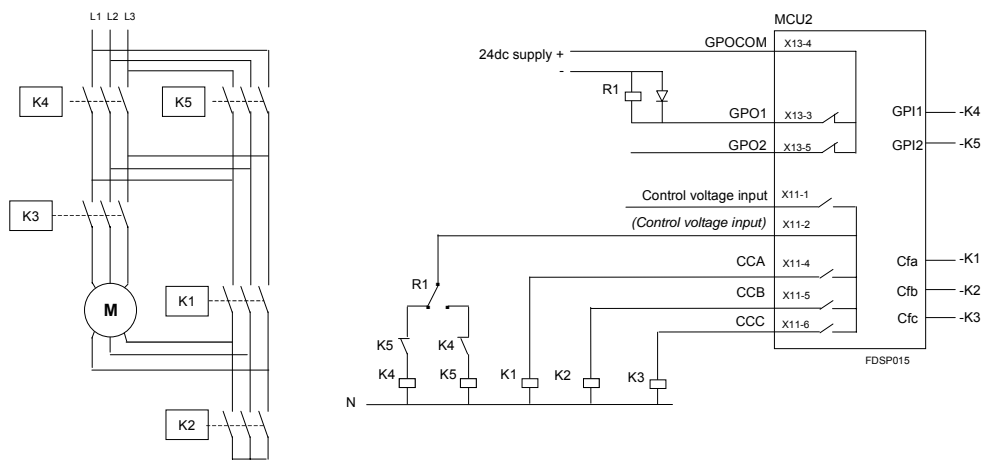

**Picture 29.** Control circuit for REV-2N starter with separate windings.

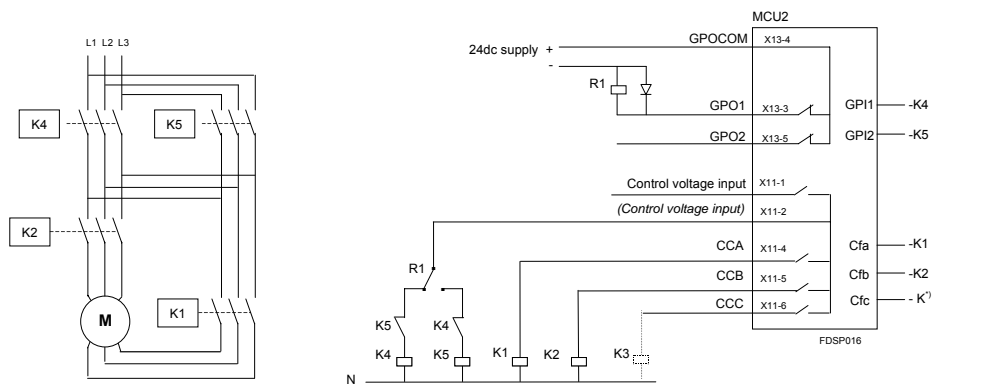

<sup>K3</sup> Feedback signal Cfc must be connected for feedback supervision.  
Recommended connection is to use a relay to simulate missing contactor.  
Optionally feedback can be connected in parallel from contactor -K2 (not recommended).

**4.1.14 Actuator starter**

Actuator starter is for controlling valves and actuators by using limit switches.

**Table 36.** Actuator starter contactor control interface.

Name	Pin	Description
CCWDLI	X11:01	Contacteur control voltage input with watchdog relay
CCLI	X11:02	Contacteur control voltage input
CCA	X11:04	Contacteur control A
CFA	X14:07	Contacteur control A feedback input
CCB	X11:05	Contacteur control B
CFB	X14:08	Contacteur control B feedback input
OPEN	X11:06	Motor start 1 switch input (CW, Open)
CLOSE	X13:13	Motor start 2 switch input (CCW, Close)
LIMIT1	X13:18	Limit position switch 1 input
LIMIT2	X13:19	Limit position switch 2 input
CFC	X13:20	Contacteur control C feedback input, torque 1 option (drawer external)
GPI1	X13:21	General purpose input 1, torque 2 option (drawer external)

**Notes:**

**Picture 30.** Control circuit for Actuator starter with limit switches, MCU2.

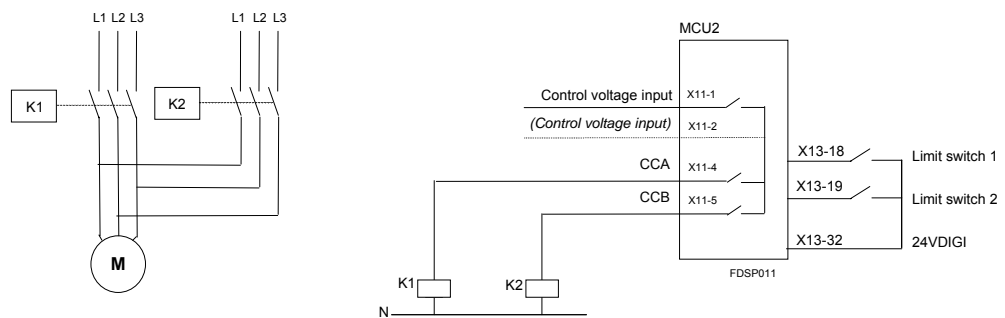

Limit switch causes the motor to be stopped when activated. Event message is sent to the fieldbus according to activated limit switch and additionally start command is allowed only to reverse direction.

**Table 37.** Active limit switch and event message.

Switch input	Description	Event message
Limit switch 1	Motor stopped when limit switch 1 activated	Motor stopped by limit position 1
Limit switch 2	Motor stopped when limit switch 2 activated	Motor stopped by limit position 2

**Picture 31.** Control circuit for Actuator starter with torque switch, MCU2.

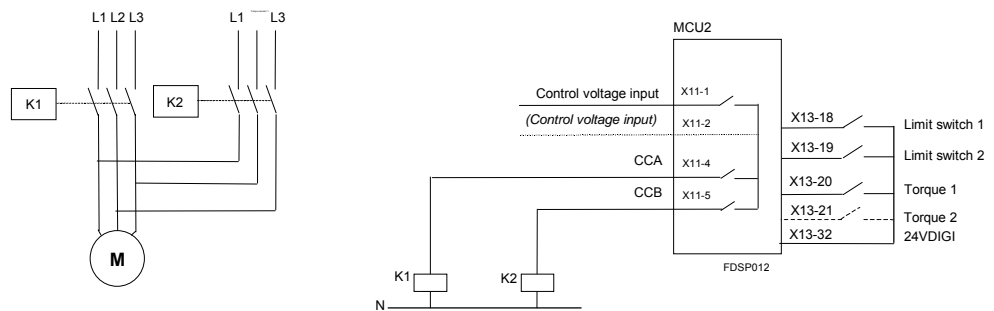

The use of torque switch is selected by setting the parameter for Actuator type, see table 37. Torque sensor can be connected to dedicated input. Torque switches are connected to inputs CFC (torque 1) and GPI1 (torque 2).

If only a single torque switch for Open and Close direction is available, the switch has to be connected to CFC (torque 1) and Actuator type 10 must be selected. See following table.

**Notes:**

**Table 38.** Possible configurations for limit and torque switch operation.

Actuator Configuration	Limit1 X13:20	Limit2 X13:19	Torque1 X13:20 (X14:9)	Torque2 X13:21 (X14:10)	Torque1 X13:20 (X14:9)	Torque2 X13:21 (X14:10)
	Open position	Close position	Open position <sup>1)</sup>	Close position <sup>1)</sup>	Open travel <sup>2)</sup>	Close travel <sup>2)</sup>
1	Stop	Stop	Not relevant	Not relevant	Not relevant	Not relevant
2	Stop	Return <sup>3)</sup>	Not relevant	Not relevant	Not relevant	Not relevant
3	Return <sup>3)</sup>	Stop	Not relevant	Not relevant	Not relevant	Not relevant
4	Stop	Stop	Not relevant	Not relevant	Trip	Trip
5	Stop	Return <sup>3)</sup>	Not relevant	Not relevant	Trip	Trip
6	Return <sup>3)</sup>	Stop	Not relevant	Not relevant	Trip	Trip
7	TORQUE1 <sup>4)</sup>	TORQUE2 <sup>4)</sup>	Stop	Stop	Trip	Trip
8	Stop	TORQUE2 <sup>4)</sup>	Not relevant	Stop	Trip	Trip
9	TORQUE1 <sup>4)</sup>	Stop	Stop	Not relevant	Trip	Trip
10	TORQUE1 <sup>5)</sup>	TORQUE1 <sup>5)</sup>	Stop <sup>5)</sup>	Not relevant	Trip	Not relevant

- <sup>1)</sup> Open (and close) position of torque switch is always indicated by the corresponding limit switch (when active).  
<sup>2)</sup> Open (and close) position of torque in travel is always an activated torque switch alone, meaning actuator in the middle of transition area at the time of input activates.  
<sup>3)</sup> Return is an automatic control function, which is activated when the tagged input has been activated.  
<sup>4)</sup> If torque (1 or 2) is activated after corresponding limit switch only the limit switch position is indicated and actuator is stopped.  
<sup>5)</sup> TORQUE1 reads the state of single torque switch output (combined open and close state).

**4.1.15 Autotransformer starter**

This starter type is used to control autotransformer unit in order to minimize the voltage drop during motor startup. Autotransformer starter with three contactors supports motor starting with reduced voltage thus providing reduced motor startup current. The starting torque will be reduced accordingly.

**Table 39.** Autotransformer starter contactor control interface.

Name	Pin	Description
CCWDLI	X11:01	Contactorm control voltage input with watchdog relay
CCLI	X11:02	Contactorm control voltage input
CCA	X11:04	Contactorm control A
CFA	X14:07	Contactorm control A feedback input
CCB	X11:05	Contactorm control B
CFB	X14:08	Contactorm control B feedback input
CCC	X11:06	Contactorm control C
CFC	X14:09	Contactorm control C feedback input (drawer internal)
	X13:20	Contactorm control C feedback input (drawer external)
START1	X13:12	Motor start 1 switch input (CW, Open)
STOP	X13:14	Motor stop switch input

**Notes:**

**Picture 32.** Control circuit for autotransformer starter, example 1, MCU2.

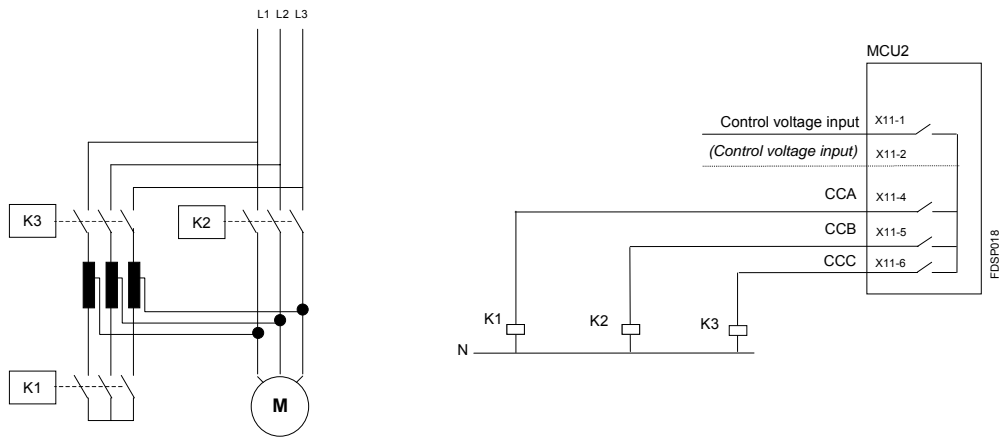

**Picture 33.** Control circuit for autotransformer starter, example 2.

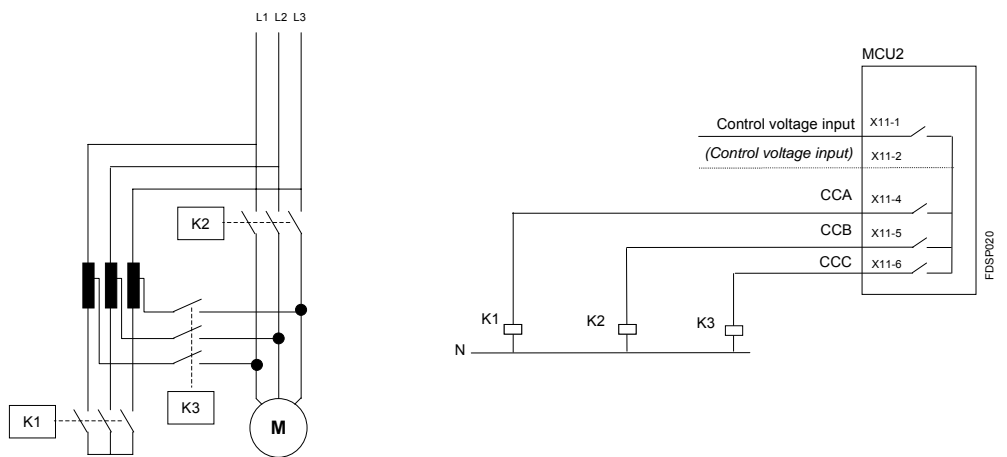

**Picture 34.** Control circuit for autotransformer starter, example 3.

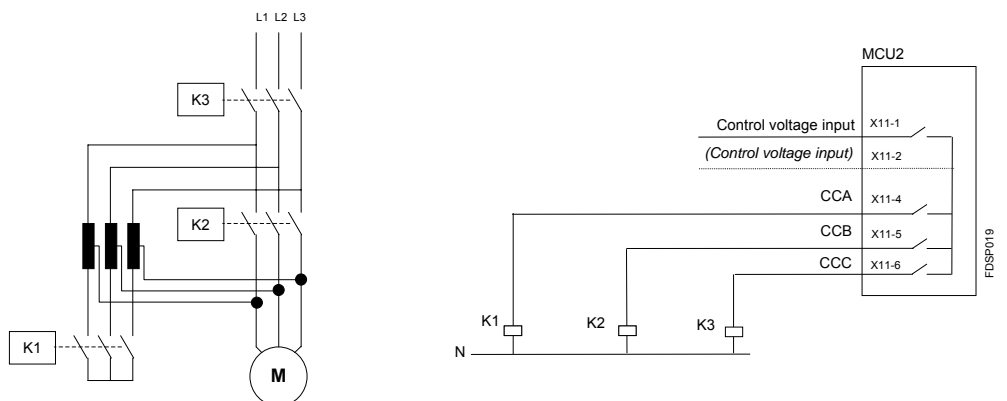

All protection functions are supported by this starter type during normal "Running" situation. For motor starting additional set of protection functions are disabled for the time *Autotrafo start time* parameter defines. For more information see chapter 'Protection functions disabled'.

Control circuit is implemented by using three contactors for contactor control. The variants supported by this implementation are presented in appendix section of this document.

The user can control starter (start and stop command) like any other starter type and motor will be stopped by activated protection function. For motor start two timers are implemented, see picture below.



**Notes:**

After selecting autotransformer starter type and connecting hardware appliances to MCU, unit user must consider the timing that is required with the particular motor and process.

Timing, i.e. timers for motor start with autotransformer are started at the moment when motor start command has been executed and first contactor control command is activated, see picture above.

With parameter *Autotrafo start time* the user can select how long time the motor will be started with reduced voltage. Predefined protection functions are disabled automatically as mentioned earlier.

After *Autotrafo start time* has elapsed, motor is connected to line voltage. While *Motor startup time* is active, protection functions listed earlier are disabled.

The following guideline applies for selecting parameter values.

$$\text{Autotrafo start time} < \text{Motor startup time}$$

**4.2 Protection functions**

**4.2.1 Protection functionality**

Protection functions provide the functionality for Motor Control Unit to protect electrical three / single phase motor against overload or other fault situations, which may cause motor damage. These functions are mainly based on current measurement but some of utilizes also voltage measurement or other provided measurement (PTC, rotation sensor, RCT).

Functionality of protection functions is based on the parameters given by user. The operating of separate functions is independent thus protection functions can be active at the same time but the one which indicates the situation first will give a trip for motor. This is depending on trip level and trip delay settings.

As an example of a case, the latest active alarm is showing different reason than the trip was caused by. Situation may occur if alarm message by a protection function is issued in between alarm and trip levels for other protection function causing the trip. This is an overlapping of protection function's alarm levels and can be noticed viewing all issued alarm messages, message buffer.

**4.2.2 Protection functions disabled**

There are certain situations where parts of the protection function are disabled because of their nature and functionality. These limited situations are presented in the following table.

**Note!** EEx e-parameters for TOL protection function can be used with NR-DOL, REV-DOL and Actuator starter types.

**Table 40.** Disabled protection during following conditions.

Protection function	Motor startup time/ Motor startup time N2	No. of phases: <b>one phase</b> selected	Parameter			
			Autotrafo start time	Softstart ramp time/ Softstop ramp time		
				start	stop	
Phase loss protection <sup>1</sup>	X	X	-	X	-	
Unbalance protection	X	X	-	X	-	
Rotation monitor protection	X	-	-	-	-	
Stall protection	X	-	-	-	-	
Underload cosphi protection	X	-	-	X	-	
Underload protection	-	-	X	X	-	
"O/L alarm" message	X	-	-	-	-	
"Motor still running" trip	-	-	-	-	X	

<sup>1</sup> If motor startup current is over 1.5 times of parameterised motor nominal current (Inom) in motor start up phase then Phase loss protection is not disabled (blocked out) by parameters Motor startup time / Motor startup time N2 / Softstart ramp time.

**Notes:**

**4.2.3 Protection functions supported**

MCU1 and MCU2 have following set of protection functions. For more specified description about functionality refer to corresponding chapter.

**Table 41.** Protection function set according to variation.

	MCU1	MCU2
Thermal Overload Protection (TOL)	X	X
Standard	X	X
EEx e	-	X
Phase loss	X	X
Phase unbalance	-	X
No Load	X	X
Underload	X	X
Underload cosphi	-	X <sup>1)</sup>
Stalled	X	X
Undervoltage	-	X <sup>1)</sup>
Rotation monitor	-	X
Motor temperature protection (PTC)	-	X
Earth fault	-	X
Start limitation	-	X
Start interlock	-	X

<sup>1)</sup> Voltage unit required

**4.2.4 Thermal overload protection**

**4.2.4.1 Thermal overload protection overview**

Thermal overload protection (TOL) protects the motor against overheating. The motor thermal condition is simulated by a calculation. The result of the calculation, i.e. thermal capacity ( $\theta$ ), is stored in the thermal register. The value stored in the thermal register is reported via unit interface to other devices capable to interpret the value, i.e. local operating panel (MMI).

Motor control unit (MCU1 and MCU2) simulates motor thermal capacity level both when motor is running and stopped. Simulation is based on the calculation that uses the highest of three measured phase currents ( $I_{L>}$ ) and the parameterized thermal model of the motor. Practically, unit simulates motor thermal behavior through one point in motor construction, called as "hot spot".

Calculation is accomplished in different motor operating conditions. The principle is presented in the following picture. Thermal increase and decrease are simulated by TOL protection function for running and stopped motor.

**Picture 35.** Principle picture of motor thermal simulation.

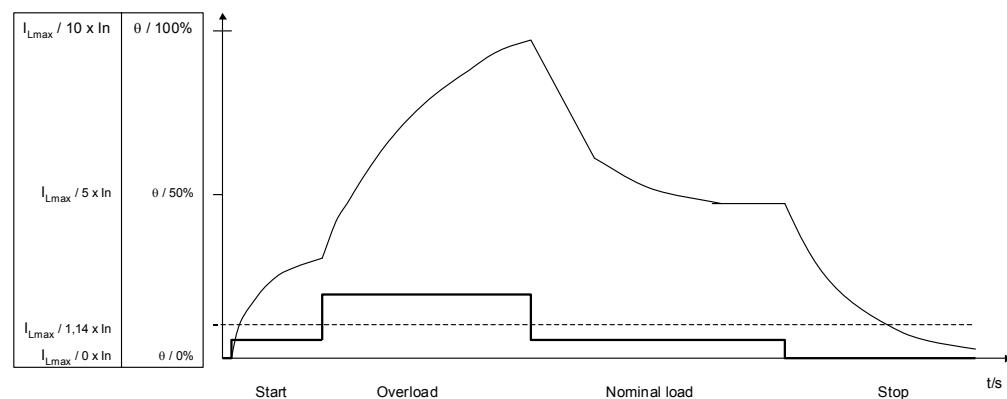

**Notes:**

**4.2.4.2 Terminology for thermal protection function**

The following terminology is used in this document.

**Table 42.** Occurrence of abbreviations.

Abbreviation	Explanation
$I_{TOL}$	Current for TOL simulation, measured current including factors for calculation
$M_{UNBA}$	Unbalance coefficient multiplier
TFLC	Thermal full load current multiplier reduced by motor ambient temperature
$I_n$	Motor nominal current setting of MCU, parameter <i>nominal current</i>
$I_{Lmax}$	Measured highest phase current value
$I_{Lmin}$	Measured lowest phase current value
$I_{nLmax}$	Previous value for measured highest phase current
$\theta$	Thermal register value, i.e. thermal capacity
$\Delta\theta$	Change in previous and new calculated thermal capacity values
$\theta_{n-1}$	Previous calculated thermal capacity value
$\theta_B$	Thermal memory, thermal background level
$\theta_s$	Thermal startup inhibit level and trip reset level
$\theta_{al}$	Thermal protection alarm level, parameter <i>TOL alarm level</i>
$\theta_{al\ reset}$	Thermal protection alarm reset level, 4% of $\theta_{al}$
$\Delta t$	Effective time in seconds
K	Time constant factor
$I_a$	Rated stall current for EEx e motor
$M_{t6}$	Cooling down time multiplier
$t_6$	Current 6 x TFLC, <i>trip class</i> parameter
$t_s$	Motor startup time, parameter <i>Motor startup time</i>
$I_s$	Motor startup current ratio, parameter <i>startup I ratio</i>

**Notes:**

**4.2.4.3 Parameters used by thermal protection function**

The following list consists of the parameters related to thermal protection in Motor Control Unit.

**Table 43.** Motor Control Unit parameters.

Parameter name	Explanation
Thermal model	0 = Standard
Nominal current	Motor nominal current setting
Motor ambient temp.	Motor ambient temperature setting
Startup I Ratio	Motor startup current ratio
Motor startup time	Motor startup time
Trip class / t6 time	Trip time for current $I_{Lmax} = 6 \times I_n$
Cooldown time factor	Cooling time multiplier when stopped
TOL alarm level	Defines alarm level
Trip reset mode	Thermal protection reset behaviour
<b>MCU2 parameters only</b>	
Thermal model	0 = Standard, 1 = EEx e
TOL bypass command	Bypass function enable/disable
Ia/In ratio	Motor stall current factor
Te time	Time to trip with stall current
<b>Two-speed parameters</b>	
Nominal current N2	Motor nominal current for second speed
Startup I Ratio N2	Motor startup current ratio for second speed
Motor startup time N2	Motor startup time for second speed
Trip class / t6 time N2	Trip time for current $I_{Lmax} = 6 \times I_n$ for second winding
Ia/In ratio N2	Motor stall current factor for second winding
Te time N2	Time to trip with stall current for second winding

**4.2.4.4 Calculation in general**

**4.2.4.4.1 Thermal model**

There are two separate thermal models available in MCU units. However, MCU1 support only TOL standard model while MCU2 unit has both TOL standard model and TOL EEx e model.

The motor thermal simulation for these models is presented in this section.

**4.2.4.4.2 Motor current for thermal capacity calculation**

MCU, motor control unit, uses the highest measured phase current ( $I_{Lmax}$ ) for the calculation of the motor thermal capacity.

Simulation considers, while motor actual load, also motor phase unbalance and motor rated ability to load in ambient temperature.

**4.2.4.4.3 Motor phase current unbalance**

In unbalance situation, where unbalance exceeds 20 %, the negative sequence in remaining phases is taken into calculation so that the highest phase current value is related to unbalance value. The highest phase value multiplier varies linearly from 1 in normal situation to 1.577 in total phase loss situation. The functionality of the thermal model is according to the IEC947-4-1 sub-clause 7.2.1.5.2 in case of phase loss.

**4.2.4.4.4 Motor thermal full load current (TFLC)**

Thermal capacity calculation uses the device internal parameter Thermal Full Load Current, TFLC, as the nominal thermal current. TFLC, is the motor *Nominal current* ( $I_n$ , parameter) related to the motor ambient temperature, parameter *Motor ambient temp.*

**Notes:**

**4.2.4.4.5 Maximum thermal capacity level**

The maximum allowed thermal capacity level is 100 % with the exception of by-pass functionality mentioned later in this document. Maximum level is reached when motor has been running with a current 6 x TFLC at the time  $t_6$  starting from the cold state.

**Table 44.** IEC 60947-4-1 trip clas when ambient temp. 40°C, balanced motor current.

Trip class	$T_6$
10A	3-7
10	7-12
20	10-25
30	15-38

When the calculated thermal capacity level reaches 100% the simulated motor thermal level has reached its maximum allowed value and the motor thermal overload trip will occur.

With motor current less than 1.14 x TFLC the thermal overload trip will not occur. However, after motor current of 1.05 x TFLC for two hours, a current greater than 1.2 x TFLC will lead to thermal overload trip within 2 hours (IEC 60947-4).

**4.2.4.4.6 Thermal capacity calculation after auxiliary power restore**

Motor thermal simulation is executed while unit is operative. However, in case of auxiliary power loss, simulation has functionality that saves every last thermal capacity value ( $\theta$ ) of the calculation in case of power supply failure.

When MCU unit is re-powered, the stored thermal capacity level is taken as the last simulated thermal level of the motor. Thus, motor highest thermal capacity will not exceed the maximum limit due to inoperative protection unit.

Thermal capacity calculation continues from the level of stored value. When the first time synchronization from the network is received, stored thermal capacity level is corrected according to delay time. If the time synchronization occurs after the time 128 x  $t_6$ , or is negative, the thermal capacity level is reset to zero.

**4.2.4.4.7 Time constant factor (K)**

Time constant factor (K) for a protection unit defines the motor warming up time constant for a protection unit. The factor is achieved from the definition of maximum current during allowed time for a motor to run without being damaged. These are different in motors designed for standard and EEx e applications.

The time constant is automatically calculated by MCU unit. It is separately calculated for a thermal protection standard model and EEx e model.

**4.2.4.4.8 Time constant factor ( $M_{t6}$ )**

Time constant factor ( $M_{t6}$ ) simulates motor cooling down for a stopped motor. In most of the cases, motor cooling is depending on the blowing fan on the motor main shaft. Thus running motor has more effective cooling and simulation uses different time constant for stopped and running motor.

This time constant is a parameter, which can be set by user. Normally, for a motor where fan is operative according to motor, thermal cooling down is 3...4 times slower than warming up. Normal value is 4 for these motors.

**4.2.4.4.9 Startup inhibit level**

Motor startup inhibit level  $\theta_s$  is the calculated level under which a motor controlled by MCU unit can be started. The level represents the thermal capacity required for a motor to be started. Definition of this level is based on parameters given to unit, i.e. parameters *Motor startup current* ( $I_s$ ), *Motor startup time* ( $t_s$ ) and *Trip class* ( $t_6$  time).

Startup inhibit level minimum value is 20 %, i.e. startup inhibit less than 20 % can not be calculated. When the calculated thermal capacity level ( $\theta$ ) is higher than the motor startup inhibit level ( $\theta_s$ ) and motor is stopped by the user, an alarm message "*Startup inhibit trip*" is generated and contactor trip is executed.

During active startup inhibit trip motor can not be started. However trip is automatically reset after the thermal capacity is below the motor startup inhibit level ( $\theta_s$ ) again.

Startup inhibit level represents also thermal protection trip reset level. Trip executed by thermal protection can be reset after calculated thermal capacity value is below startup inhibit level ( $\theta_s$ ). Trip reset method is selectable.

**Notes:**

**Picture 36.** Startup inhibit level functionality.

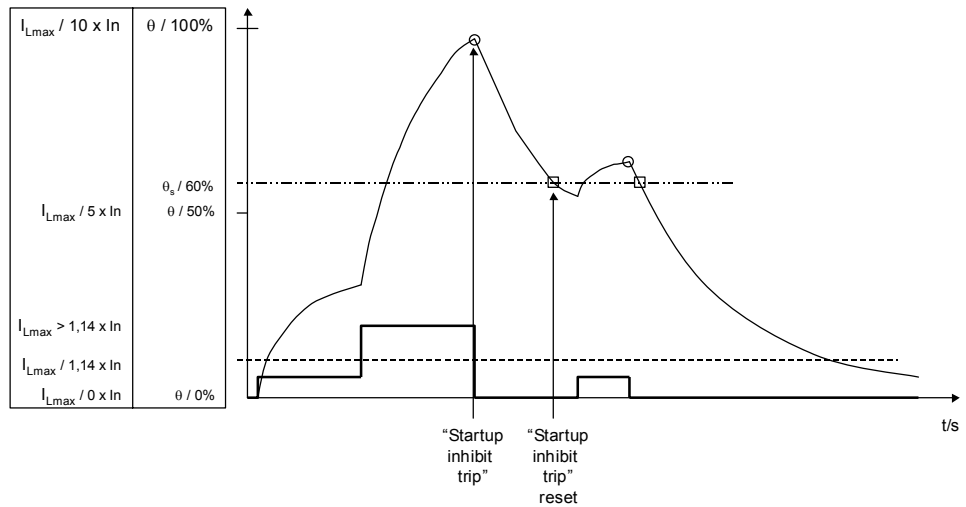

**4.2.4.5 Alarms and indications from thermal overload protection**

**4.2.4.5.1 Thermal capacity reporting**

Calculated thermal capacity ( $\theta$ ) is reported to fieldbus by MCU unit. The same value is also used by the protection function in comparison with *TOL alarm level* and trip level.

Thermal image is reported to the fieldbus with the deadband of 5 % when value is less than 90 %. When thermal capacity value has exceeded 90 %, reporting is per 1 % change.

If the thermal image is stable, there is an updating cycle to the fieldbus. Cycle can be parameterized and varies from one second to one minute.

**4.2.4.5.2 Thermal protection trip**

A fixed value is defined for motor thermal capacity ( $\theta$ ) maximum limit. When thermal capacity reaches the limit a contactor will be operated open and alarm message "*TOL trip*" is generated.

When thermal capacity has decreased below trip reset level (vs. startup inhibit level,  $\theta_s$ ) the trip can be reset. This also ensures that there is enough free thermal capacity to restart motor.

**Picture 37.** Thermal protection trip functionality (trip reset level,  $\theta_s$ ).

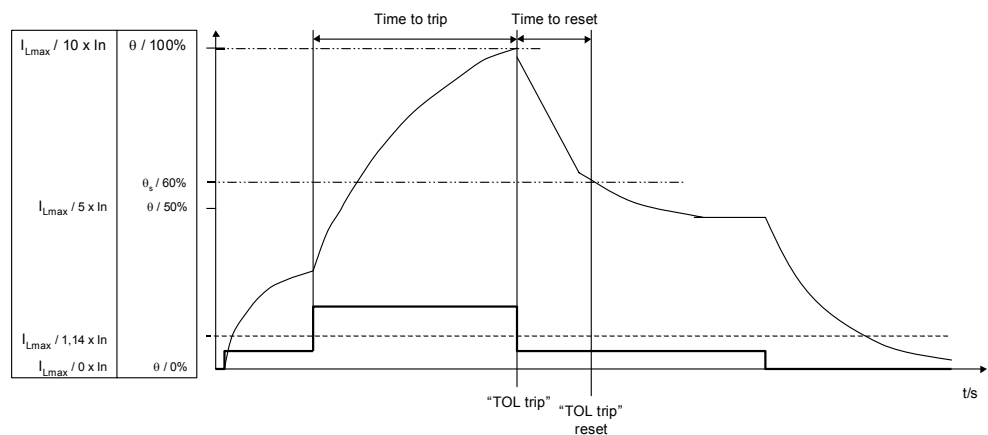

**Notes:**

**4.2.4.5.3 Thermal protection alarm indication**

A user definable limit can be set to indicate the thermal load of the motor, *TOL alarm level*. With this level unit will generate an alarm message to inform the current status of the calculated thermal capacity ( $\theta$ ).

When thermal capacity raises over thermal protection alarm level,  $\theta > \theta_{al}$ , a unit generates an alarm message "*TOL alarm*". Alarm is automatically reset when thermal capacity decreases under the level 4% of *TOL alarm level* value, i.e.  $\theta < \theta_{al\ reset}$

**Picture 38.** TOL alarm indication (*TOL alarm level*,  $\theta_{al}$  and alarm reset,  $\theta_{al\ reset}$ ).

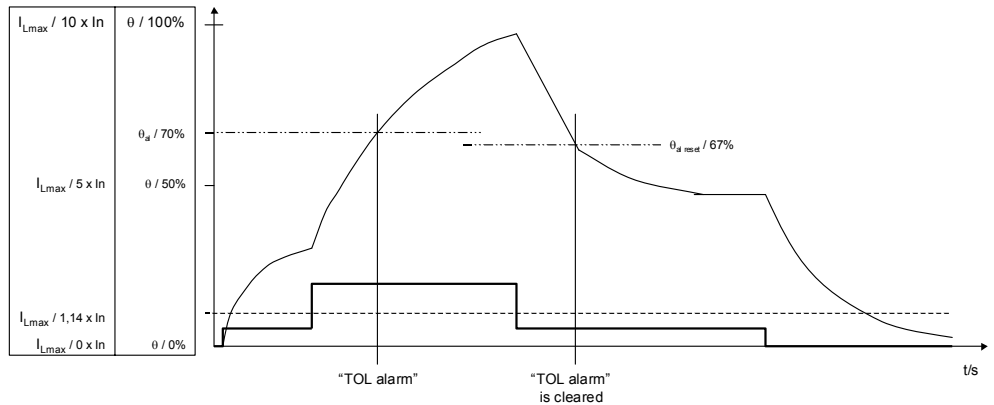

**4.2.4.5.4 Thermal protection overload alarm indication**

Overload alarm indication, alarm message "*O/L alarm*", is activated automatically when motor is overloaded, i.e.  $I_{Lmax} > 1.14 \times \text{TFLC}$  (balanced current). When overload condition is detected unit generates an alarm message to inform of overload condition.

Overload alarm reset is self-acting but there exists a 4 % hysteresis. Therefore alarm is cleared when overload condition restores under 4 % of  $1.14 \times \text{TFLC}$  (balanced current), i.e.  $I_{Lmax} < 1.10 \times \text{TFLC}$ .

Thermal overload alarm also indicates the thermal overload trip in finite time. The calculated time to trip is reported to the fieldbus whenever overload condition is active.

**Picture 39.** Thermal protection overload alarm indication.

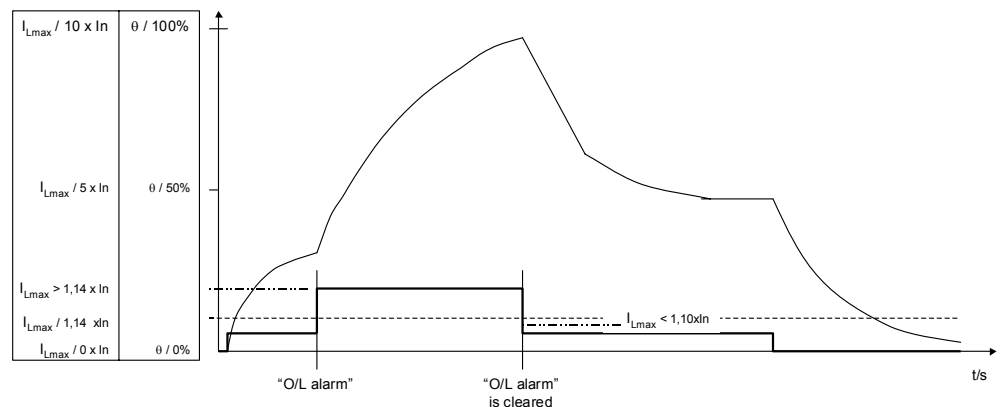

**4.2.4.5.5 Time to trip and time to reset reporting from thermal protection**

During overload condition MCU monitors the time to trip value, this is the estimated time of the thermal capacity level to reach 100 %.

The calculated estimated time to trip value is reported to the fieldbus with a fixed deadband of 25 % of the previous reported value or every 10 second, if the value has not changed more than 25 % from the last reported value within the last 10 seconds.

Current less than O/L alarm level makes reported time to trip value 65535 seconds. That is interpreted as "not activated".

**Notes:**

After thermal protection trip MCU monitors the time to reset value. This value is an estimated time to the thermal capacity level ( $\theta$ ) to decrease below trip reset level, i.e. startup inhibit level ( $\theta_s$ ). When this occurs, an event message "TOL reset level reached" is generated to inform user of a possibility to execute a trip reset.

Time to reset value is reported with a fixed deadband of 5 seconds. If the time to reset value is below 10 seconds the value is reported every second.

**4.2.4.6 Motor warming up in different operating conditions**

With nominal load, simulated motor thermal capacity will balance about 50 % of maximum value.

During overload usage, i.e.  $I_{Lmax} > 1.14 \times TFLC$ , motor thermal behavior changes and there is more divergence in the thermal spread inside the motor. Some areas warm up faster than the rest of the motor body. Simulation changes to calculate two thermal images (section two in following picture).

Thus, simulation starts to calculate two thermal values. First, the fast rise in motor body (hot spot) is simulated as a highest thermal value ( $\theta$ ). Highest calculated thermal value is always reported to fieldbus. Then the unit calculates the background thermal level ( $\theta_B$ ) which represents the average heating in the middle of the stator-windings.

**Picture 40.** Thermal level increase during motor operating condition.

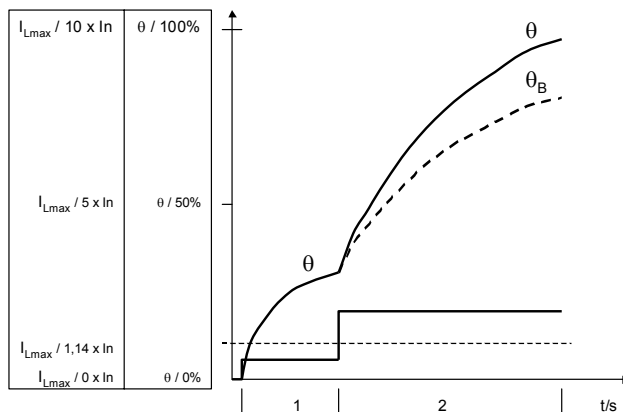

**4.2.4.7 Motor cooling down in different operating conditions**

**4.2.4.7.1 Cooling down from an overload condition with a fixed slope**

When motor load is balanced to nominal load, stopped or tripped after a period of overload, the cooling down is started. Cooling down starts with a linear drop of thermal capacity ( $\theta$ ). Linear stage is fixed 0.2 % / second. It is active in order to reach the value of background thermal level ( $\theta_B$ ) (section 3 in the picture below).

This represents the fast cooling down of hot parts in a motor body either for stopped or tripped motor or motor with nominal load.

**Picture 41.** Cooling down for a stopped or running motor.

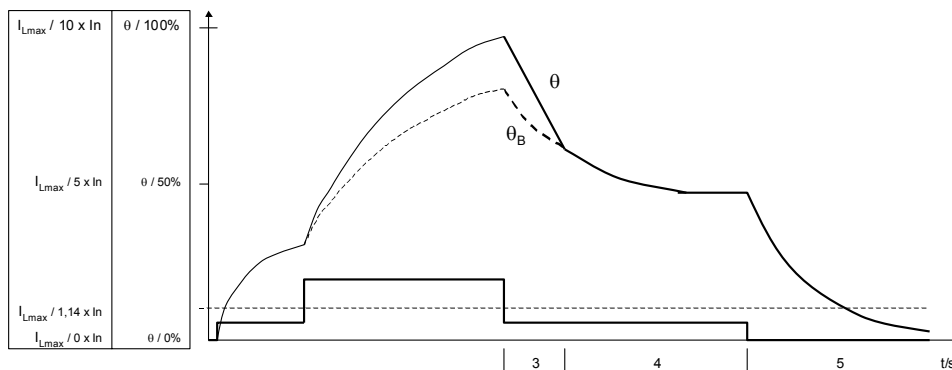



**Notes:**

**4.2.4.7.2 Running with nominal load**

Motor load is reduced to nominal, i.e.  $I_{Lmax} < 1.14 \times TFLC$ .

After overload situation thermal level calculation uses constant factor 0.2 %/sec until  $\theta = \theta_B$ . Refer to previous picture section 3 and 4.

**4.2.4.7.3 Motor is stopped or tripped**

Motor is not loaded, i.e.  $I_{Lmax} = 0$

Thermal level calculation uses parameter that denotes for motor slower cooling down, the time constant factor ( $M_{t6}$ ). Previous picture, section 5, presents the cooling of stopped motor.

**4.2.4.8 Thermal overload protection additional features**

**4.2.4.8.1 TOL EEx e thermal model**

In the flameproof applications, special 'EEx e-motors' are used. For these motors, two specific parameters are defined:

- Stall/nominal current ( $I_A/I_N$ ) –ratio
- $t_e$  -time.

When TOL EEx e model is applicable, i.e. selected with parameter *Thermal model*, these two parameters pass by the  $t_6$  -parameter and the supposed respective stall/nominal current ratio of six (6) in TOL protection calculations, as explained earlier in chapter "Time constant factor (K)".

Parameter  $t_e$  -time gives the maximum time the stall current ( $I_A$ ) may exist without any spot in the motor surface achieve the maximum temperature allowed by the environment class definition.

When TOL EEx e model is selected, TOL-bypass functionality, explained later, is not available.

**4.2.4.8.2 Automatic Restart after TOL-trip**

In addition to thermal protection function presented above there are few additional features in Motor Control Unit 2 (MCU2). These are explained in this section.

MCU2 offers a special reset mode for thermal protection trip. This is called a 'Restart' reset mode. If this reset mode is activated motor will start automatically when it has cooled down to startup inhibit level ( $\theta_s$ ) allowing trip reset.

The restart will take place to the direction and at the speed, which were active before the trip.

**4.2.4.8.3 TOL-bypass command**

In some applications, it is beneficial to be able to bypass the TOL protection momentarily because of the process reasons. The lifetime of the motor will be shortened but it will be more costly to stop the process. TOL-bypass is a special command given through the fieldbus.

There is a dedicated parameter to enable the execution of this command. TOL-bypass function is available only for TOL standard model; it can not be enabled if TOL EEx e model is in use.

When thermal level is above parameterized alarm level there is a possibility to send a bypass command to MCU2. When bypass function is activated, the thermal image is allowed to rise to 200 % level before a trip will occur.

If motor is in overload condition, i.e.  $I_{Lmax} > 1.14 \times TFLC$ , the O/L alarm is active to indicate overload, but time to trip is not updated if the thermal capacity level ( $\theta$ ) is not going to rise above 200 % ( $I_{TOL} < \sqrt{2}$ ). If motor is stopped before trip and the thermal capacity decreases below *TOL alarm level* the bypass functionality is disabled. Bypass command is ignored when running under alarm level.

Fieldbus interface provides the information when the TOL bypass functionality is activated. Timetag of the latest TOL-bypass command and the number of the commands are stored and provided as statistical values.

**4.2.4.8.4 Two-speed (N2) motor applications**

MCU2 supports the use of two speed motor (N2). When selected with parameter *Starter type*, MCU2 calculates separate thermal capacity levels for both speeds separately, but practically this refers to motor windings. However, there is a fixed relation 100% between thermal transition among motor windings, which states for the principle that both windings have the same thermal image.

The thermal capacity for winding currently in use ( $\theta$ ) and thermal capacity in background ( $\theta_B$ ) are calculated as explained earlier in this document.

**Notes:**

When there is a speed change, the parameters used for thermal calculation are switched accordingly, i.e. In setting,  $t_b$  time, etc.

**Picture 42.** Thermal simulation principle for two speed motor.

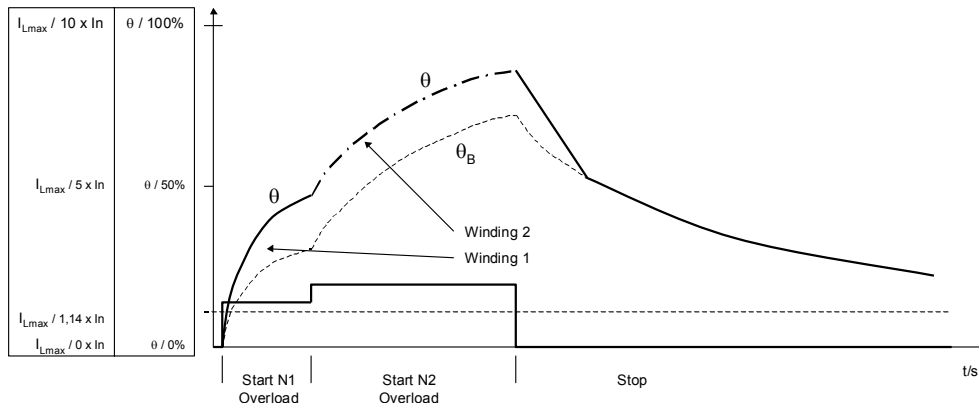

**4.2.5 Phase loss protection**

MCU protects the motor against phase current loss condition. Phase loss protection function uses highest and lowest measured phase currents ( $I_{Lmin}$  and  $I_{Lmax}$ ) together with the following parameters. Function is suppressed by parameters *Motor startup time* (*Motor startup time N2*), *Number of phases* and *Softstart ramp time*.

**Please note!**

If motor startup current is over 1.5 times of parameterised motor nominal current ( $I_{nom}$ ) in motor start up phase then Phase loss protection is not disabled (blocked out) by parameters *Motor startup time* / *Motor startup time N2* / *Softstart ramp time*.

**Table 45.** Phase loss protection parameters.

Function	Parameter name
Phase loss protection	Alarm level
Phase loss protection	Trip level
Phase loss protection	Trip delay

**Picture 43.** MCU phase current loss protection.

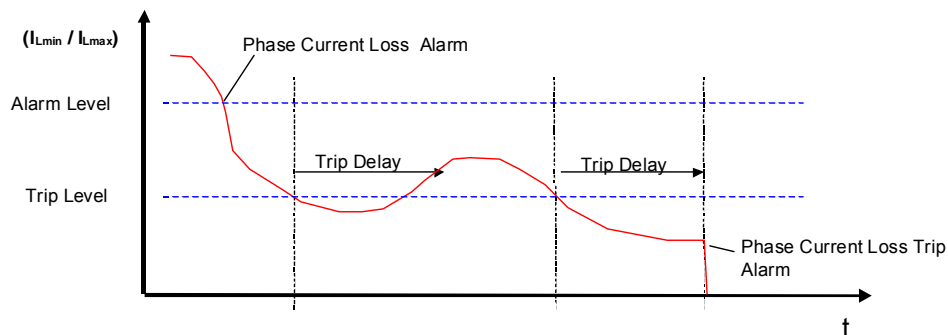

$I_{Lmin}/I_{Lmax}$  is compared against the phase loss *Alarm level* parameter. When  $I_{Lmin}/I_{Lmax}$  decreases below the *Alarm level*, an "Phase Loss alarm 1/2/3" alarm is issued.

$I_{Lmin}/I_{Lmax}$  is compared against the phase loss *Trip level* parameter. When  $I_{Lmin}/I_{Lmax}$  remains below the *Trip level* at a time longer than *Trip delay*, an "Phase Loss Trip 1/2/3" alarm is issued and the contactor tripped.

**Notes:**

**4.2.6 Underload protection**

MCU protects the motor against underload condition. Underload protection function uses the highest measured phase current ( $I_{Lmax}$ ) together with the following parameters. Function is suppressed by parameters *Autotrafo start time* and *Softstart ramp time*.

**Table 46.** Underload protection parameters.

Function	Parameter name
Underload protection	Alarm level
Underload protection	Trip level
Underload protection	Trip delay

**Picture 44.** MCU underload protection.

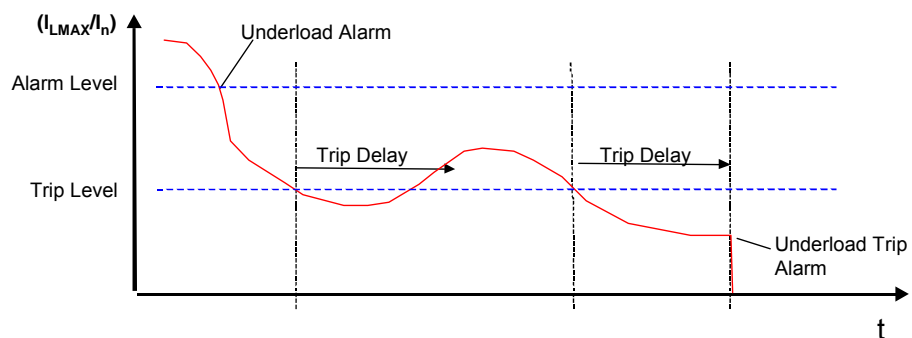

The highest measured phase current ( $I_{Lmax}$ ) is compared against the underload *Alarm level*. When  $I_{Lmax}$  decreases below the *Alarm level*, an “U/L alarm” alarm is issued.

The highest measured phase current ( $I_{Lmax}$ ) is compared against the underload *Trip level*. When  $I_{Lmax}$  remains below the *Trip level* at a time longer than underload *Trip delay*, an “U/L Trip” alarm is issued and the contactor tripped.

*Trip level* can be parameterized to zero to have no trip at all but only an alarm.

**4.2.7 Underload cosphi protection**

MCU2 protects the motor against underload condition based on cosphi detection together with the following parameters. Function is suppressed by parameters *Motor startup time (/Motor startup time N2)* and *Softstart ramp time*.

**Table 47.** Underload cosphi protection parameters.

Function	Parameter name
Underload cosphi protection	Alarm level
Underload cosphi protection	Trip level
Underload cosphi protection	Trip delay

**Notes:**

**Picture 45.** Underload cosphi protection.

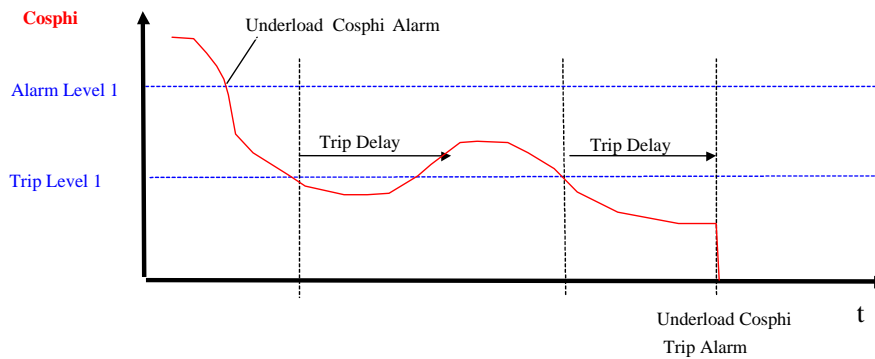

The cosphi value is compared against the underload cosphi *Alarm level*. When cosphi decreases below the *Alarm level*, an “U/L Cosphi alarm” alarm is issued.

The cosphi is compared against the underload cosphi *Trip level*. When cosphi remains below the *Trip level* at a time longer than underload cosphi *Trip delay*, an “U/L Cosphi Trip” alarm is issued and the contactor tripped.

In parametering the underload protection based on cosphi detection the absolute value of cosphi is used without the sign.

**4.2.8 No load protection**

Practically no load protection is the same function than underload protection. Parameter limits by default are different and messages issued by these functions.

MCU protects the motor against no load condition. No load protection function uses the highest measured phase current ( $I_{Lmax}$ ) together with the following parameters:

**Table 48.** No load protection parameters.

Function	Parameter name
No Load	Alarm level
No Load	Trip level
No Load	Trip delay

**Picture 46.** MCU no load protection.

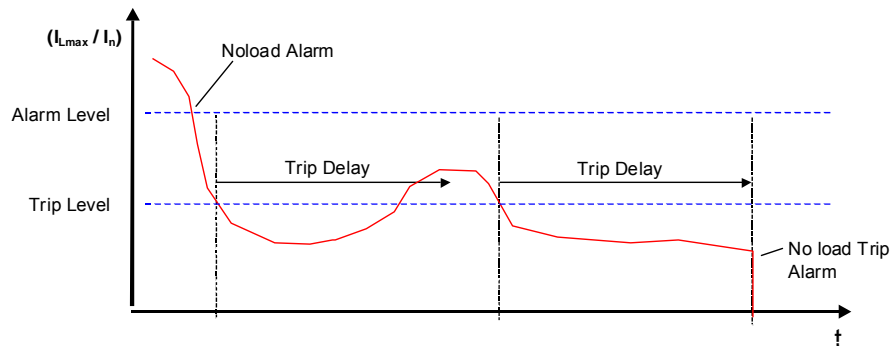

The highest measured phase current ( $I_{Lmax}$ ) is compared against the no load *Alarm level*. When  $I_{Lmax}$  decreases below the *Alarm level*, an “N/L alarm” alarm is issued.

The highest measured phase current ( $I_{Lmax}$ ) is compared against the *Trip level*. When  $I_{Lmax}$  remains below the *Trip level* at a time longer than *Trip delay*, an alarm “N/L Trip” is issued and the contactor tripped.

**Notes:**

**4.2.9 Stall protection**

MCU protects the motor against stalled condition. Stall protection function uses the highest measured phase current ( $I_{Lmax}$ ) together with the following parameters. Function is suppressed by parameter *Motor startup time* (/Motor startup time N2).

**Table 49.** Stall protection function parameters.

Function	Parameter name
Stall protection	Alarm level
Stall protection	Trip level
Stall protection	Trip delay

**Picture 47.** MCU stall protection.

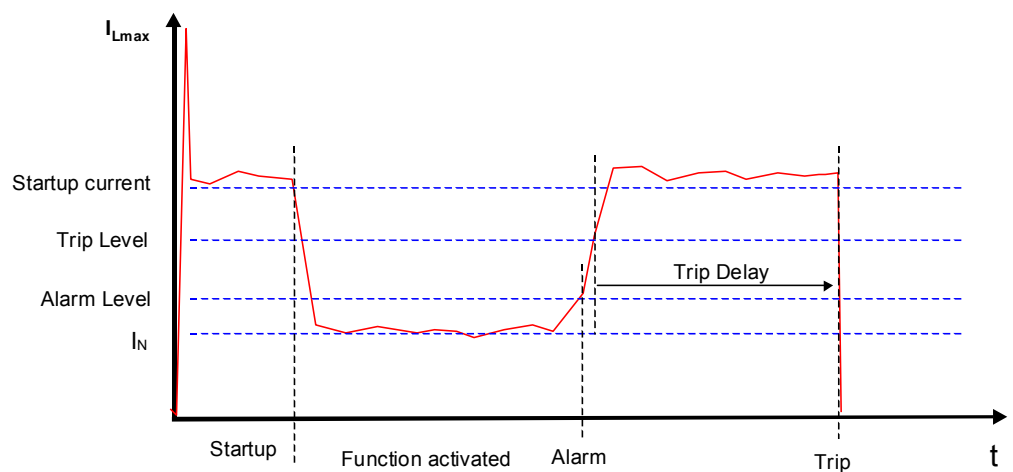

Stall function activates after the motor startup is completed (highest measured phase current  $I_{Lmax}$  decreases less than  $1.25 \times I_N$ ) or motor nominal startup time has elapsed.

The highest measured phase current ( $I_{Lmax}$ ) is compared against the *Alarm level*. When  $I_{Lmax}$  raises over the stall protection *Alarm level*, an “*Stall alarm*” alarm is issued.

The highest measured phase current ( $I_{Lmax}$ ) is compared against the *Trip level*. When  $I_{Lmax}$  remains over the *Trip level* at a time longer than *Trip delay*, a “*Stall Trip*” alarm is issued and the contactor tripped.

**4.2.10 Earth fault protection**

The earth fault protection protects the motor against the earth fault condition. MCU2 have two different ways to detect the earth fault current. Either of the methods can be selected at a time:

- Detecting from the measured phase currents, vector sum of the phase currents differs from zero.  
Function is suppressed by parameter *Number of phases*.
- Measuring by Residual Current Transformer, with output of  $10 V_{p-p}$ .

The levels are expressed as absolute values. In case the vector sum of the phase currents is used as detection method of the earth fault current, the maximum sensitivity is proportional to the nominal current of the motor (15 % of the nominal current setting).

**Note!** If accuracy of earth fault protection is required, the measured function has to be used.

**Notes:**

Earth fault protection uses parameters as in the following table.

**Table 50.** Earth fault protection parameters.

Function	Parameter name
Earth fault	Method
Earth fault	Residual CT primary
Earth fault	Alarm level
Earth fault	Trip level
Earth fault	Trip delay

Earth fault protection method based on phase vector sum calculation depends on the current measurement zero current limit. If more sensitive earth fault protection is required, measurement with external residual current transformer is recommended. RCT is recommended especially in the distribution networks, which are floating or connected to the ground by resistor.

In earth fault protection the symmetrical three phase network is assumed. The earth fault protection will not be sensitive to symmetrical earth faults.

**Picture 48.** MCU2 earth fault protection.

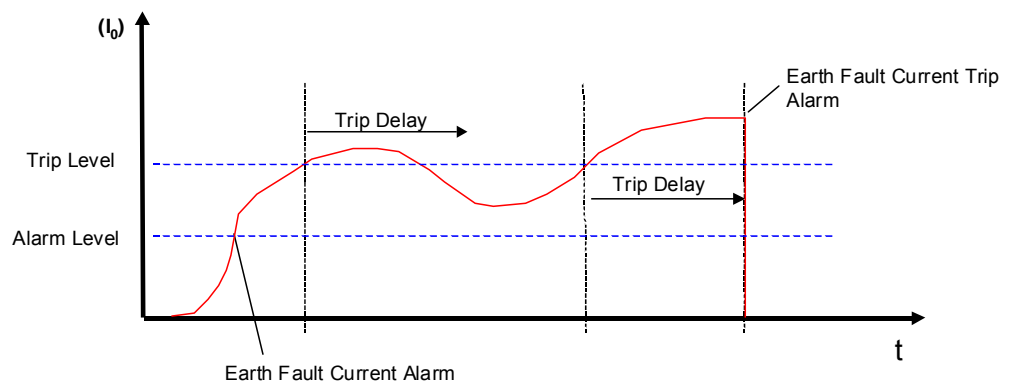

$I_0$  is compared against the earth fault current *Alarm level*. When  $I_0$  exceeds above the *Alarm level*, an "Earth Fault Current alarm" alarm is issued.

$I_0$  is compared against the earth fault current *Trip level*. When  $I_0$  remains above the earth fault current *Trip level* at a time longer than *Trip delay*, an "Earth Fault Current Trip" alarm is issued and the contactor tripped.

**4.2.11 Unbalance protection**

MCU2 protects the motor against phase current unbalance condition. Unbalance protection function uses all the measured phase currents ( $I_L$ ) together with the parameters listed below. Function is suppressed by parameters *Motor startup time* (*Motor startup time N2*), *Number of phases* and *Softstart ramp time*.

**Note!** Unbalance protection has practically the same function as phase loss protection, except that parameters are presented differently and the limits are different as well as messages initiated by these functions are different.

**Table 51.** Unbalance protection parameters.

Function	Parameter name
Unbalance protection	Alarm level
Unbalance protection	Trip level
Unbalance protection	Trip delay

**Notes:**

**Picture 49.** MCU2 unbalance protection.

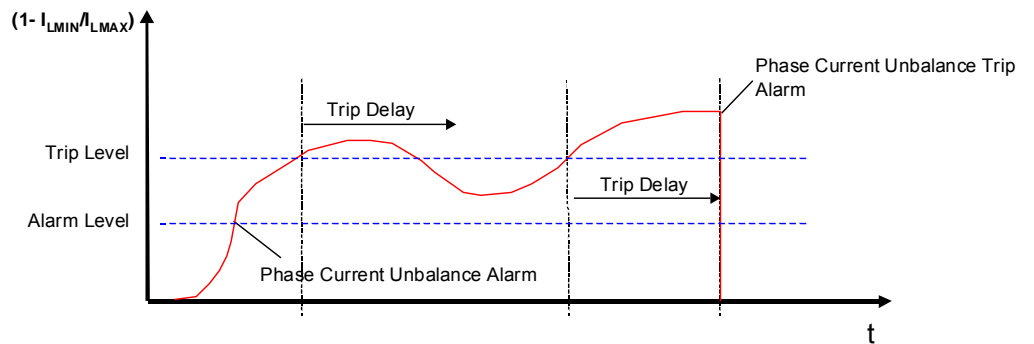

$(1 - I_{Lmin}/I_{Lmax})$  is compared against the unbalance *Alarm level*. When  $(1 - I_{Lmin}/I_{Lmax})$  exceeds above the unbalance *Alarm level*, an "Phase Current Unbalance alarm" alarm is issued.

$(1 - I_{Lmin}/I_{Lmax})$  is compared against the unbalance *Trip level*. When  $(1 - I_{Lmin}/I_{Lmax})$  remains above the unbalance *Trip level* at a time longer than *Trip delay*, an "Phase Current Unbalance Trip" alarm is issued and the contactor tripped.

**4.2.12 Rotation monitor protection**

MCU2 protects the motor against locked rotor condition. Locked rotor is detected by an external sensor/rotation monitoring unit connected to MCU input. Sensor detects locked rotor and creates a signal indicating the fault to MCU unit. Trip level setting depends on sensor type and its parameters, if any exists. Function is suppressed by parameter *Motor startup time (/Motor startup time N2)*.

**Table 52.** Rotation monitor parameters.

Function	Parameter name
Rotation monitor protection	Trip delay

**Picture 50.** MCU2 rotation monitor protection.

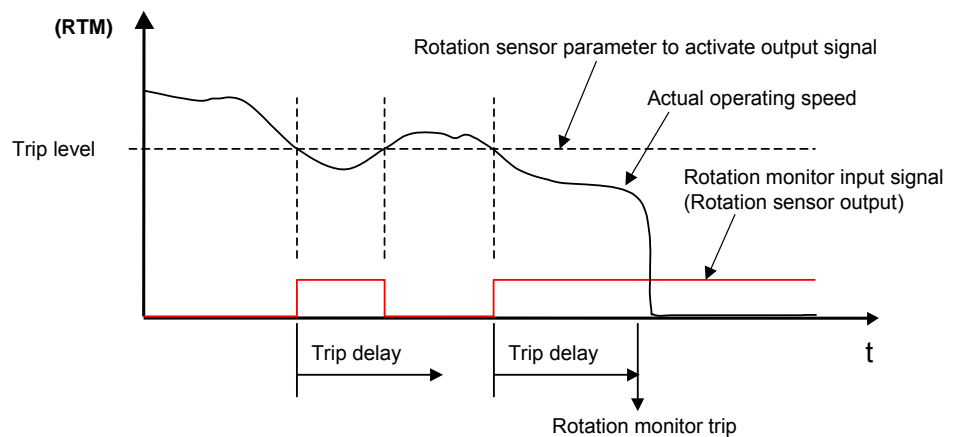

The MCU compares the signal from rotation monitor input to *Trip delay* parameter and when fault remains longer than delay allows a "RTM Trip" alarm is issued and the contactor tripped.

**Notes:**

**4.2.13 Thermal protection**

Thermal protection in MCU2 protects the motor against too high temperature by using PTC-sensor(s). PTC input is used to measure the resistance of the connected PTC sensor. Thermal protection uses the following parameters.

**Table 53.** Thermal protection parameters.

Function	Parameter name
Thermal protection	Alarm level
Thermal protection	Cable compensation
Thermal protection	Short circuit trip level

All the levels are expressed in Ohms.

**Picture 51.** Thermal protection with PTC.

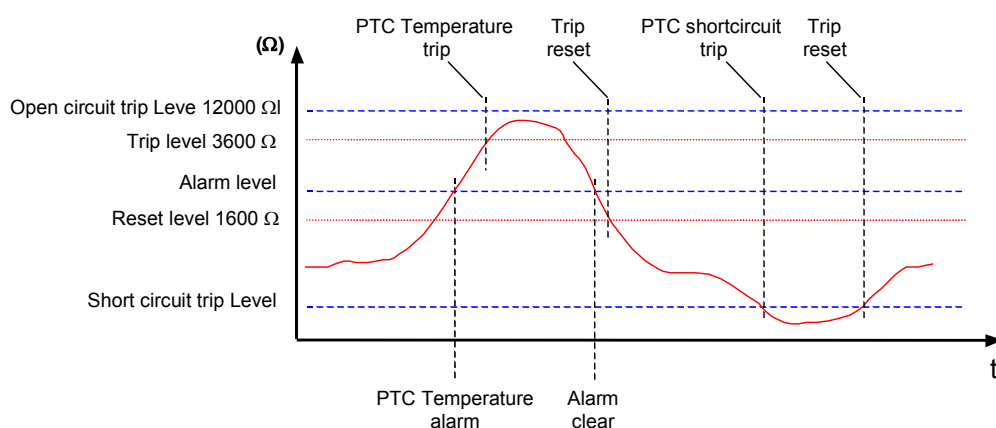

The resistance of PTC input is compared against the *Alarm level*. When resistance of PTC input exceeds above the *Alarm level*, an "PTC alarm" message is issued.

The resistance of PTC input is compared against the fixed PTC trip level 3600 Ω and when resistance of PTC input is above the trip level "PTC temperature trip" alarm is issued and the contactor tripped.

After PTC trip is executed, the resistance of PTC input is compared against the fixed PTC reset level 1600 Ω. When resistance of PTC input decreases below the reset level, the PTC protection function executes the function parameterized by "PTC Reset Mode".

The resistance of PTC input is compared against the *Short circuit trip level*. When resistance of PTC input decreases below the *Short circuit trip level*, a trip is executed and an "PTC shortcircuit trip" alarm is issued.

The resistance of PTC input is compared against the fixed value of 12000 Ω open circuit trip level. When the resistance of PTC input increases above the open circuit trip level, a trip is executed and an "PTC open circuit trip" alarm is issued.

**4.2.14 Undervoltage protection**

**4.2.14.1 Normal functionality**

MCU2 protects the motor against undervoltage condition as "voltage dip". The Undervoltage protection function uses the lowest of the measured main voltages ( $U_{Lmin}$ ) together with the following parameters:



**Notes:**

**Table 54.** Undervoltage protection function parameters.

Function	Parameter
Undervoltage protection	Alarm level
Undervoltage protection	Trip level
Undervoltage protection	Trip delay
Undervoltage protection	Reset voltage level
Undervoltage protection	Max autoreclose time
Undervoltage protection	Max. power down time
Undervoltage protection	Staggered start time

All the levels are expressed as absolute values.

**Picture 52.** Undervoltage protection function.

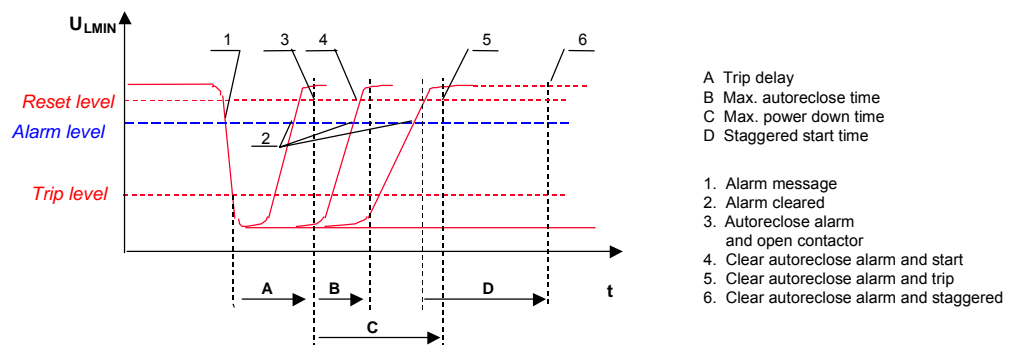

The lowest measured main voltage ( $U_{Lmin}$ ) is compared against the undervoltage *Alarm level*. When  $U_{Lmin}$  decreases below the undervoltage *Alarm level*, an "Undervoltage alarm" alarm is issued.

The lowest measured main voltage ( $U_{Lmin}$ ) is compared against the undervoltage Trip Level and voltage recovering after undefined time causes one of the following conditions (a-e):

- a) When  $U_{Lmin}$  recovers, above undervoltage reset level before *Trip delay* expires
- motor continues running.

**Note!** When trip delay is used contactor auxiliary voltage must be secured.

- b) If  $U_{Lmin}$  remains below the reset level at a time longer than *Trip delay*
- "Autoreclose alarm" is issued
  - contactor will be opened (motor state remains 'running').

**Note!**

- If trip delay is not required it should be set to zero (*Trip delay* parameter)
  - After  $U_{Lmin}$  is below undervoltage *Trip level* all protection functions based on current measurement and feedback supervision functions are disabled.
- c) When the  $U_{Lmin}$  recovers above reset level before *Max. autoreclose time* elapses
- "Autoreclose alarm" is cleared and
  - motor is started without a delay.
- d) If the  $U_{Lmin}$  recovers above the reset level at a time shorter than *Max. power down time*
- after Staggered start time parameter "Autoreclose alarm" is cleared
  - contactor will be closed.

**Note!** In case of autoreclose with staggered start, the time between motor is stopped and remain in automated start is cumulated *Trip Delay* + *Max. power down time* + *Staggered start time*.

- e) If the  $U_{Lmin}$  remains below the reset level at a time longer than *Max. power down time*
- "Autoreclose alarm" is cleared,
  - "Undervoltage trip" is issued and
  - motor state will be changed to 'tripped'.

### Notes:

The minimum length of a voltage dip detected by MCU is 100ms due to the cycle time of voltage measurement.

Total loss of auxiliary power supply for MCU with motor main voltage can last up to 250 ms. For longer total voltage loss MCU will not start motor automatically but will use autoreclose in staggered mode, even if the *Trip delay* has not elapsed.

When MCU detects two undervoltage situations during one second it will automatically enter to staggered start according to *Staggered start time* parameter.

**Note!** In Undervoltage situation Phase Loss Alarm appears and will stay, because Phase Loss Alarm is based on current, not on voltage. The alarm is set when current is below parameterized level in one or two phases and cleared when motor is stopped, tripped or when all currents are back at runs-state.

#### 4.2.15 Start limitation protection

MCU2 can be parameterized to limit the number of starts during a time interval. This is done by parameters:

**Table 55.** Start limitation parameters.

Function	Parameter name
Start limitation protection	Number of starts
Start limitation protection	Time interval

Functionality is presented in the following example. The next picture presents the start limitation protection with 3 starts allowed.

1. Normal situation, after stop command motor can be started normally, "Start 2". Every start activates an internal timer for the time defined by *time interval* parameter. The number of active timers are reviewed after every stop command and compared to value of *number of starts* parameter. Stop command can thus exist during active or elapsed timer.
2. Two timers are still active, thus stop command generates alarm message "Start limitation alarm" and one more start is allowed, "Start 3".
3. The 3<sup>rd</sup> start has been executed. A contactor trip and trip message "Start Limitation Trip" alarm will follow when motor is stopped while there are two active timers, here starting from "Start 1". When start limitation trip is active, the time to reset is provided to the fieldbus.
4. Trip can be reset when the first timer from "Start 1" is finished. Motor start is possible when all pending trips are reset. Supervision continues with a new timer from "Start 4".

**Note!** Maximum time for trip situation is as parametrised by start limitation *Time interval* parameter.

**Picture 53.** Start limitation for *Number of starts* 3 within *Time interval*.

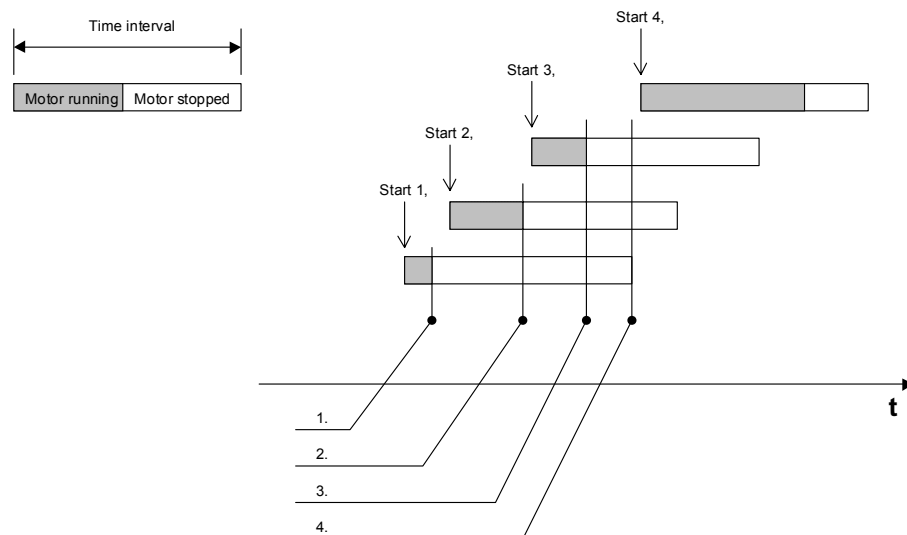

**Notes:**

**4.2.16 Start interlock protection**

In MCU2 user have a possibility to set a minimum time delay before a new start of motor is possible. This is achieved with a timer who is activated by the last stop of motor and counts the time set to the parameter. This is done by parameters:

**Table 56.** Start limitation parameters.

Function	Parameter name
Start interlock protection	Interlock time

**Picture 54.** Start interlock operation principle.

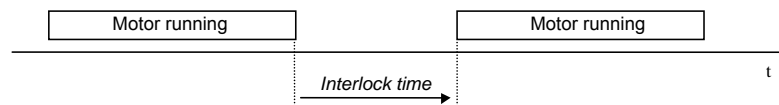

**4.3 MCU function and supervision**

**4.3.1 Contactor watchdog**

MCU has an internal watchdog relay on the contactor control voltage line in series with the contactor control relays (CCA, CCB and CCC). This relay is controlled by monostable multivibrator timer, which needs to be cyclically refreshed by the microprocessor (30 ms cycles of refreshing pulses) in order to stay closed.

When no refreshing pulse occurs it is assumed that the microprocessor SW/HW does not run properly. When refreshing pulse missing, after 120 ms delay the contactor watchdog relay opens causing the control voltage to disappear from the contactors.

Contactor watchdog relay can be opened intentionally by the microprocessor by stopping the refreshing, see chapter "Feedback supervision".

Contactor watchdog can be bypassed by using the CCLI input for control voltage.

**Note!** It is recommended to use watchdog in the control circuit for all starter types.

**4.3.2 Device self supervision**

During the normal microprocessor shutdown sequence (power off etc.), a special 'shut down sequence completed' flag to the non-volatile memory will be set. This indicates the normal termination of the software.

MCU has an internal hardware watchdog supervising the behavior of the microprocessor software. If the watchdog is not refreshed within a one-second period it will cause reset to microprocessor, called as watchdog reset.

If watchdog reset occurs, a 'shut down sequence completed' flag to the non-volatile memory will not be set. This indicates the abnormal termination of the microprocessor software.

After the device powered up, it is checked if the 'shut down sequence completed' flag is set properly. In this case, the normal initialization routine will be performed and the flag will be cleared.

On the other cases, microprocessor will generate an "Internal fault trip" alarm indicating the device needs to be maintained/replaced.

**Note!** A 'R/C circuit' shall be used on the contactor to avoid unexpected "Internal fault trip" alarm caused by voltage peaks during switching cycles of the contactors.

**4.3.3 Feedback supervision**

Feedback supervision monitors the status of motor and contactor after control command (open/close or close/open) given by MCU. Status is checked by using feedback signals (CFA, CFB and CFC) wired from contactor auxiliary contacts and by current measurement.

**Notes:**

**Table 57.** Feedback supervision input connectors and pins.

Conn./Pin	Name	Description / Indication	MCU1	MCU2
X14:07	CFA	Contactor control A feedback input / "Feedback alarm A" alarm (obj.ID 10 code 0x20) "Feedback Trip A" alarm (obj.ID 10 code 0x30)	X	X
X14:08	CFB	Contactor control B feedback input / "Feedback alarm B" alarm (obj.ID 11 code 0x20) "Feedback Trip B" alarm (obj.ID 11 code 0x30)	X	X
X14:09/ X13:20	CFC	Contactor control C feedback input (drawer internal) / Contactor control C feedback input, torque input (actuator) / "Feedback alarm C" alarm (obj.ID 9 code 0x20) "Feedback Trip C" alarm (obj.ID 9 code 0x30)	-	X
X14:10/ X13:21	GPI1	Contactor control D feedback input (drawer internal) / Contactor control D feedback input (drawer external) / "Feedback alarm D" alarm (obj.ID 22 code 0x20) "Feedback trip D" alarm (obj.ID 22 code 0x30)	-	X
X14:11/ X13:22	GPI2	Contactor control E feedback input (drawer internal) / Contactor control E feedback input (drawer external) / "Feedback alarm E" alarm (obj.ID 23 code 0x20) "Feedback trip E" alarm (obj.ID 23 code 0x30)	-	X

A selectable *Feedback delay* defines the maximum time for a contactor to follow the control given by MCU (CCA, CCB or CCC). Feedback supervision activates, if contactor state and measured current status does not correspond to actual control when supervision delay has elapsed.

**Table 58.** Feedback delay range.

	Minimum / ms	Maximum / ms
t1	100	5000

**Picture 55.** Contactor operation within *Feedback delay*.

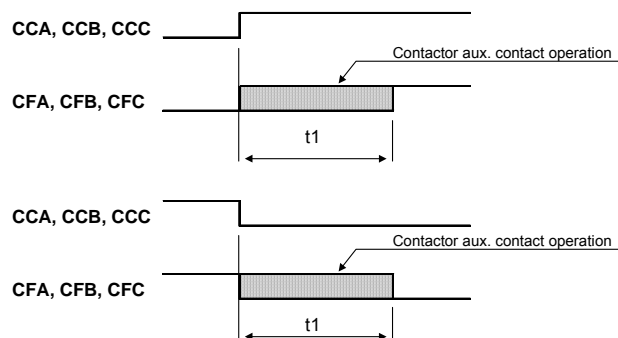

When enabled by parameterization, feedback supervision cyclically checks the contactor auxiliary contact statuses. If a difference between the control status and auxiliary status is detected, an alarm message is issued. If there is difference between control status and current measurement a trip message is issued and contactor is tripped as stated in the tables below.

The contactor which has the problem (alarms and trips with extension /CT in the tables below) can be identified.

In case of current is measured without any action in contactor control, an alarm is issued and contactor is tripped, but the indication of the contactor is not got (alarms and trips with extension /AM in the tables below).

If there is a current detected and contactors are controlled open, the contactor watchdog is operated.

**Notes:**

**Table 59.** Truth table of the contactor supervision in the normal mode.

Normal mode			NR-DOL, REV-DOL		NR-DOL/RCU	
current	aux. contact <sup>1)</sup>	desired state	alarm/trip	comment	alarm/trip	comment
0	0	0	--	OFF	---	OFF
0	0	1	Trip/CT	Control voltage failure	---	RCU-OFF
0	1	0	Alarm/CT	Feedback alarm	Alarm/CT	no load
0	1	1	Trip/CT	No load	Trip/CT	no load
1	0	0	Trip/AM	WD	Alarm/AM	feedback alarm
1	0	1	Alarm/CT	Feedback alarm	Alarm/CT	feedback alarm
1	1	0	Trip/CT	WD	---	RCU-ON
1	1	1	---	ON	---	ON

**Table 60.** Truth table of the contactor supervision in the test mode.

Test mode			NR-DOL, REV-DOL		NR-DOL/RCU	
current	aux. contact <sup>1)</sup>	desired state	alarm/trip	comment	alarm/trip	comment
0	0	0	--	OFF	---	OFF
0	0	1	Trip/CT	Control voltage failure	---	RCU-OFF
0	1	0	Alarm/CT	Feedback alarm	---	RCU-ON
0	1	1	---	ON	---	ON
1	0	0	Trip/AM	Test Mode Trip	Trip/AM	Test Mode Trip
1	0	1	Trip/AM	Test Mode Trip	Trip/AM	Test Mode Trip
1	1	0	Trip/AM	Test Mode Trip	Trip/AM	Test Mode Trip
1	1	1	Trip/AM	Test Mode Trip	Trip/AM	Test Mode Trip

<sup>1)</sup> Column aux. contact refers to CCA in NR-DOL and NR-DOL/RCU and both CCA and CCB (/CCC) in reversing starters.

**Table 61.** Truth table for contactor CCB (/CCC), NR-DOL/RCU mode only.

Aux. Contact	Desired state (CCB/CCC)	Alarm/Trip	Comment
0	0	--	ON/OFF
0	1	Trip	aux. CT
1	0	Alarm	aux. CT
1	1	--	OFF

**Note!** When MCU is in test mode and parameterized as a NR-DOL or REV-DOL and with latched or RCU, CCC will not operate if CFA or CFB is already inactive.

**Notes:**

**4.3.4 Main switch in test position**

When the switch disconnecter test-position input is activated, an event is generated by MCU. While in test position, MCU monitors the I/O -statuses and phase currents. Contactor operations by MCU are allowed but all the current based protection functions are disabled to allow control circuitry testing. However, if any phase current is detected, a "Testmode failure trip" alarm is issued and contactor is tripped.

**Table 62.** Main switch test input connectors and pins.

Conn./Pin	Name	Description / Indication	MCU1	MCU2
X14:01	TEST	Switch disconnecter "Test" input and LON "Service" input/ "Switch-disconnector switched to test position" event	X	X

**4.3.5 Miniature circuit breaker release**

When Miniature Circuit Breaker (MCB) input is activated, e.g. by an event causing power supply fail to motor starters, MCU executes a trip and issues an alarm.

**Table 63.** Miniature circuit breaker input connectors and pins.

Conn./Pin	Name	Description / Indication	MCU1	MCU2
X14:06	MCB	Auxiliary contact from miniature circuit breaker / "MCB trip" alarm	X	X

**4.3.6 Emergency stop**

This input indicates the status of emergency stop switch and prevents the further control of contactors before switch is released.

When emergency stop switch is operated unit executes a trip and indicates the cause of trip.

**Table 64.** Emergency stop input connectors and pins.

Conn./Pin	Name	Description / Indication	MCU1	MCU2
X13:17	EMSTOP	Auxiliary contact input from emergency stop switch / "EM-Stop activated" alarm	X	X

**4.3.7 External trip**

There are two different ways for external trip supported by MCU unit. Trip command can be given either through unit's I/O or through network interface.

When either of trip input is activated unit executes a trip and indicates the cause of trip.

**Table 65.** External trip input connectors and pins.

Conn./Pin	Name	Description / Indication	MCU1	MCU2
X14:03	EXTRIP	External trip input / "External I/O trip" alarm	X	X

**Table 66.** External trip network variable input.

[Network variable index]	Name	Description / Indication	MCU1	MCU2
[29]	nviTrip	External trip input / "External trip" alarm.	X	X

**4.3.8 Main switch trip**

Main switch input indicates the status of motor feeder main switch. When input is activated, an alarm is issued and contactor is tripped.

The main switch trip is automatically reset after main switch input is not activated.

**Notes:**

**Table 67.** Main switch input connectors and pins.

Conn./Pin	Name	Description / Indication	MCU1	MCU2
X14:02	SD	Switch disconnecter 0/1 position input / "Main switch OFF" alarm.	X	X

**4.3.9 General purpose interface**

**4.3.9.1 General purpose input**

There are two separate general input in MCU2 unit that can be used for reading binary data via unit I/O. For active/inactive input, user can define separate value with parameters. This extends the variety of implementations.

When input is activated the value given in parameter is sent to fieldbus and accordingly for input becoming inactive. For more information see chapter "MCU interfaces" of this document.

**Note!** General purpose inputs are reserved for REV-2N, REV-SD and Actuator starter types.

**Table 68.** General purpose input connectors and pins.

Conn./Pin	Name	Description	MCU1	MCU2
X13:21 X14:10	Gpl1	General purpose 1 input	-	X
X13:22 X14:11	Gpl2	General purpose 2 input	-	X

**Table 69.** General purpose input connectors and pins.

[Network variable index]	Name	Description	MCU1	MCU2
[74]	nvoGpln1	General purpose input 1 output	-	X
[75]	nvoGpln2	General purpose input 2 output	-	X

**4.3.9.2 General purpose output**

There are two separate general purpose output signal relays in MCU2 unit. These are for general use like two inputs presented above.

To activate output, user must write to network variable input the value, which is defined in corresponding parameter. Values are defined separately for active and inactive output. For more information see chapter "MCU interfaces" of this document.

**Note!** General purpose output 1 is reserved for REV-2N and REV-SD starter types.

**Table 70.** General purpose output connectors and pins.

Conn./Pin	Name	Description	MCU1	MCU2
X13:03	GpO1	General purpose 1 output	-	X
X13:05	GpO2	General purpose 2 output	-	X

**Table 71.** General purpose network variable inputs.

[Network variable index]	Name	Description	MCU1	MCU2
[70]	nviGpOut1	General purpose output 1 input	-	X
[71]	nvoGpOut1Fb	General purpose output 1 feedback output	-	X
[72]	nviGpOut2	General purpose output 2 input	-	X
[73]	nvoGpOut2Fb	General purpose output 2 feedback output	-	X

**Notes:**

### 4.3.10 Contactor switch cycles

MCU counts switch cycles for contactor control output (CCA, CCB and CCC). For each complete (close-open) contactor cycle MCU sends the number of operating cycle to the fieldbus and updates counters to the preset file. When contactor switch cycle is exceeded, MCU issues an alarm.

**Note!** Contactor control outputs CCD and CCE do not have a cycle counter.

**Table 72.** Network variable output for contactor switch cycle reporting.

[Network variable index]	Name	Description/ Indication	MCU1	MCU2
[41]	nvoOpCount1	Number of operation cycles CCA / "Maintenance A" alarm.	X	X
[43]	nvoOpCount2	Number of operation cycles CCB / "Maintenance B" alarm.	X	X
[39]	nvoOpCount3	Number of operation cycles CCC / "Maintenance C" alarm.	X	X

### 4.3.11 Motor running hours

MCU counts also motors running hours. Motor running hours are reported to the fieldbus and updated to the preset files. When operating running hours limit will be crossed MCU issues an "Maintenance hours run" alarm.

**Table 73.** Network variable output for contactor switch cycle reporting.

[Network variable index]	Name	Description/ Indication	MCU1	MCU2
[33]	nvoCumRunT	Motor running hour counter / "Maintenance hours run" alarm.	X	X

**Note!** Resolution for this function is in seconds.

### 4.3.12 Failsafe functionality

MCU failsafe function supervises the network interface and connection to the remote devices controlling the motor/starter equipment by MCU. Remote device have to refresh the certain MCU network input variable to indicate that the control is operating normally and the network interface is in good condition.

If a loss of communications is detected the failsafe activates with the parameterized function as follows:

- No operation
- Start motor direction 1
- Start motor direction 2
- Stop motor

**Table 74.** Network variables for failsafe function.

[Network variable index]	Name	Description/ Indication	MCU1	MCU2
[31]	nviFailsafe	Failsafe refresh input variable / "Failsafe activated" alarm.	X	X
[32]	nvoFailsafeFb	Failsafe input feedback information	X	X

Failsafe function is operational only after the input variable is first time refreshed. That means, the network communication over the fieldbus is established.

The variable can have the following values:

- Normal Operation (00) - failsafe refresh
- Enter to failsafe mode (1...254) - enter to failsafe state
- Ignore failsafe function (255) - disable failsafe function

When the failsafe function activates, MCU releases the motor remote control (when applicable) automatically by releasing the Control Access table and issues an alarm message.

For further information on the Failsafe function in INSUM refer to the document 'INSUM Failsafe Guide'.



**Notes:**

**4.4 Time synchronization**

All alarm and event data generated by the MCU include a timetag, which is based on the synchronized absolute system time.

MCU supports message based time synchronization. When receiving time synchronization messages MCU synchronizes its internal clock with the new absolute time received in the time synchronization message.

**Table 75.** Network variables for time synchronization.

[Network variable index]	Name	Description / Indication	MCU1	MCU2
[2]	nviTimeSet	Time input based on SNVT_ time format	X	X
[8]	nviClockWrng	Warning message input (ABB time format)	X	X
[7]	nviClock	Time input (ABB time format)	X	X

The absolute system time in the INSUM will be synchronized by the system clock device located in SU. System clock device broadcasts time synchronization messages within a configurable time band to all devices within the bus hierarchy. These time synchronization messages include the absolute time.

**Picture 56.** INSUM time synchronization.

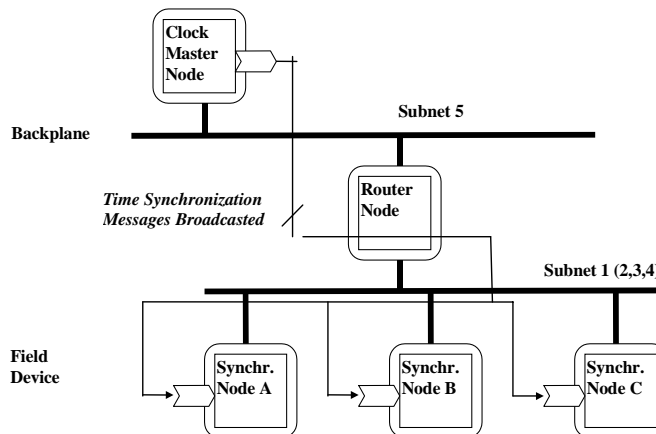

For the time synchronization messages from system clock, MCU gives a response by sending a dedicated event for indicating valid and non-valid system time. In case of non-valid system time, Year and Month field in the event/alarm message are set and reported with zero value.

The functionality of time stamping is according to following table. Timeout is fixed 60 second.

**Table 76.** The following events are sent for an indication of time stamp validity.

MCU	"MCU synchronized by system clock" (obj.ID 7 code 0x30)	"MCU lost time synchronization" (obj.ID 1 code 0x80)	Year and Month of time stamp*
Power On or MCU reset	0	0	Year and Month fields are zero in every event/alarm
Received first time sync	1	0	Valid time stamp
Timeout without received time sync	0	1	Year and Month fields are zero in every event/alarm
Received first time sync after timeout	1	0	Valid time stamp

**Notes:**

**4.5 MCU Remote/Local control**

**4.5.1 Terminology**

**Motor control** in this context means entering the normal motor control commands, such as motor start and stop, to the MCU. Functions such as internal or external tripping and motor group starting are not considered as normal motor control commands and are therefore left outside this definition.

Normal motor control commands can be entered by using starter local switches connected directly to the MCU I/O. Control performed by MCU I/O can be called **local control**.

Motor control can also be performed by other fieldbus network devices, which enter motor control commands to the MCU via fieldbus network variables. In the MCU entering the motor control commands is limited to one network input variable. Control performed by other network devices can be called **remote control**.

**4.5.2 Remote/Local control switching**

Switching the motor control from remote to local and vice versa can be done by using the binary-I/O connected remote/local switch in the local control panel/switchgear control panel. This switch has the highest priority in the remote/local switching.

**Table 77.** Remote/local control input connectors and pins.

Conn./Pin	Name	Description / Indication	MCU1	MCU2
X13:06	LOCAL	Remote/local switch input / "Motor control switched to local" event	X	X

**Table 78.** Remote/local network variable input.

[Network variable index]	Name	Description / Indication	MCU1	MCU2
[44]	nviCAPass	Remote/local input / "Motor control switched to local" event.	X	X

Remote/local control switching can also be requested by the device/devices capable to propagate MCUs input, which is dedicated for the device state management.

If one of the two remote/local control switching algorithms requests the local control state transition, the MCU will transit to local control state. These local control requests have always the highest priority. When local control is operated corresponding event is issued by MCU and led indication is activated.

**4.5.3 Remote control access (CA)**

According to the INSUM specifications only one remote device at the time can control the motor, i.e. enter motor commands to the MCU. There is a special Control Access (CA) mechanism in the INSUM system, which defines the access priorities to different remote devices and a mechanism to request, pass and release the motor control access. For further information on the Control Access refer to the document 'INSUM Control Access Guide'.

Each MCU, when being in remote control state and CA enabled, follows the CA mechanism by detecting the motor control command source and filtering all unauthorized commands.

**Notes:**

## **5 MCU communication interface**

### **5.1 Protocol and functions**

LONTALK protocol with free topology transceiver technology is implemented to MCU units and is available for communication to INSUM motor control system. Via network interface all functions are supported, e.g.: parametering, control, supervision, etc. Software version can also be downloaded through network interface with download utility software.

### **5.2 MCU set-up**

#### **5.2.1 Network installation and configuration**

Installation in this chapter means all the operations to be performed before device is ready to be parameterized. List of such operations consists of installing device to the motor starter, powering up and performing network installation.

Network installation means creating a logical connection between the device to be installed and network configuration or parameterization tool and further entering the network configuration data to the device to be installed.

#### **5.2.2 Service / Wink installation**

The MCU offers a possibility to install the device by using the service switch connected via device I/O. Service switch input is connected to the switch-disconnector/ MCC test position input.

During the installation, the MCU to be installed is identified by switching the respective starter to Test-position. Switching the starter to Test-position results the MCU to send a service message with the device identification information to the installation tool.

After the installation tool has received a service message from the particular MCU it has information enough ("which device to install") to create a logical connection with the MCU to be installed. The installation tool can verify the connection by sending a Wink-message to the MCU, to which the MCU responds by flashing ("winking") LEDs called 'READY' and 'DFP\_READY'. After the logical connection has been created, MCU is ready for network configuration and parameterization.

### **5.3 Network variable data**

#### **5.3.1 LON Standard Network Variable Types (SNVT)**

Remote devices, such as MMI-devices or Operator Stations, can control the MCU and receive all or a subset of MCU's data via communications network by the means of network input and output variables.

The type of each network variable is defined by LON Standard Network Variable Type, SNVT. The definition of a SNVT includes unit, range, resolution and data format. SNVTs are listed in the SNVT Master List and Programmer's Guide. This list is updated by Echelon and it includes network variable types, which are commonly agreed to be used by multiple manufacturers.

Some of the user defined data types are also used e.g. combined current report including all three phase currents. For more information of the network interface see 'MCU1 and MCU2 network interface description' in appendix section.

#### **5.3.2 Self Identification and Self Documentation information (SI/SD)**

To get the information about the device and its network variables, a Self Identification and Self Documentation information (SI/SD), is stored as an array in the memory of the MCU. The SI/SD information can be read by other remote devices to find out the network variable related information from the device.

#### **5.3.3 Network variables background update**

MCU updates every network variable whenever the state or value has changed. Some network variables are updated as a background process with defined cycle.

Parameter, **Status Heartbeat**, defines cycle of the network variable nvoMotorStateExt update.

Parameter, **NV heartbeat base**, defines the background update cycle for listed network variables.

**Notes:**

**Table 79.** Background update cycle defined by NV heartbeat base (T) parameter.

Cycle		Network variable name	NV index	MCU2
4xT	Actual Control Access owner	nvoActualCA1	45	
	Alarm bit field	nvoAlarmReport	51	
	Current report	nvoCurrRep	17	
12xT	Voltage report	nvoVoltRep	55	X
	Power report	nvoPowRep	56	X
	Apparent power	nvoAppPwr	67	X
72xT	CCc switching cycles	nvoNbrOfOp3	39	X
	CCa switching cycles	nvoNbrOfOp1	41	
	CCb switching cycles	nvoNbrOfOp2	43	
	Motor run hours	nvoCumRunT	33	
	Thermal capacity	novCalcProcValue	19	
	GPI1 feedback	nvoGpIn1	74	X
	GPI2 feedback	nvoGpIn2	75	X
	GPO1 feedback	nvoGPOut1Fb	71	X
	GPO2 feedback	nvoGPOut2Fb	73	X
	Configuration CRC	nvoParFileCRC16	76	
Time to reset	nvoTimeToReset	21		
Time to trip	nvoTimeToTrip	20		

**5.4 Internal files**

**5.4.1 Device data file**

In the Device Data file are debug information of MCU's software. The Device Data file is in text format. The same information is also in the parameter value file read-only section.

**5.4.2 Alarm and event buffers**

All events and alarms are buffered to alarm and event buffer. Explained in the chapter Alarms and Events of this document.

**5.5 Alarms and events**

**Alarm** can be defined as a data or status transition **from any state to abnormal state**. Data transition to abnormal state can be data crossing over the predefined alarm limit, for example motor phase current raising over the predefined phase current alarm level. Going alarm issues when the reason for alarm is cleared.

**Event** can be defined as a data or status transition **from any state to normal state**. Data transition to normal state can be crossing the predefined limit, for example motor phase current falling from the alarm level back to the normal level.

All the alarms and events generated by the MCUs are timetagged with the device internal time when they occur. After the occurrence of alarm and event data will be reported to other devices via dedicated network output variables.

All alarm and event data is buffered in the device event and alarm repository for later delivery. Maximum of 20 events and 20 alarms are buffered in the FIFO type buffers. A FIFO type buffer with 20 entries means that the always the last 20 entries can be read from the circular buffer, oldest entries are overwritten by the latest ones.

When several alarms become active "simultaneously" from the same protection, only the most serious one will be indicated.

Alarm occurrence causes device to propagate the alarm reporting network variable where each alarm has a dedicated alarm code which is reported in the LON alarm network variable of type SNVT\_alarm.

---

# INSUM<sup>®</sup>

## MCU User's Guide

---

**Notes:**

Parametering failure alarm shows in the value field what parameter is out of the range or has some other error. The values of the value field are explained later on this document.

Event occurrence causes device to propagate the event reporting network variable. Event occurrence may also cause some other network output data, such as state data, to be propagated.

Each event has a dedicated event code, which is reported in the LON alarm network variable of type SNVT\_alarm.

Alarm and event codes are presented in the table in appendix section.

Notes:

## 6 MCU Parameterisation

### 6.1 Overview

Parameterization in this context means entering values to the MCU parameters, such as motor nominal current and  $t_6$ -time etc.

Before MCU can be parameterized, it has to be powered up and installed to the fieldbus by the installation tool/self-installation method in chapter MCU set-up of this document.

When the MCU is being parameterized, it must be set to **application offline** state. Before setting the MCU to application offline state, the motor has to be stopped. After being set to offline neither the motor nor the starter equipment can be controlled by MCU. When the MCU is set offline, "Device set to Offline" event is issued.

MCU parameters can be uploaded by and downloaded from the parametering device (e.g. MMI or INSUM Operator Station) by using the LON File Transfer. Parametering device can read the parameter file, combine new parameters to the file and download the file completely or partially back to the MCU being parameterized.

After the new parameter set was downloaded, MCU has to be set back to **application online** state. When entered to online, MCU checks parameter ranges. If there are errors detected by MCU in the parameters, a "Parametering Failure" alarm is issued and corresponding parameter ID in value field indicating the failed parameter.

For parametering failure alarm value field, see table in appendix section.

### 6.2 MCU parameters

Parameters are listed with default values in the MCU Parameter Description document.

Notes:

## 7 Technical Data

<b>Main circuit</b>	
Rated operational voltage ( $U_e$ )	400 / 690 V
Rated insulation voltage ( $U_i$ )	690 V AC
Rated impulse withstand voltage ( $U_{imp}$ )	6 kV
Rated operational current ( $I_e$ )	0.1...3.2 A or 2.0...63 A
Rated frequency	50 / 60 Hz
Frequency limits	-5%...+3 %
Rated conditional short circuit current ( $I_q$ r.m.s.)	50 kA
Current measurement range	0.05...10 x $I_n$
Voltage measurement range	0.65...1.1 x $U_n$
<b>Control circuit</b>	
Rated operational voltage ( $U_e$ )	24 V DC or 230 V AC
Rated insulation voltage ( $U_i$ )	- or 250 V
Rated impulse withstand voltage ( $U_{imp}$ )	- or 4 kV
Rated operational current ( $I_e$ )	2 A (DC-13) or 2 A (AC-15)
Rated frequency	50 / 60 Hz
Frequency limits	-5%...+3 %
Rated conditional short circuit current ( $I_q$ r.m.s.)	1 kA
Recommended safety equipment (2.0 A)	ABB Stotz-Kontakt GmbH S 271-Z2
<b>Control circuit relay output</b>	
Number of watchdog relay output MCU1 / MCU2	1
Number of contactor control relay output MCU1 / MCU2	2 / 3
Rated number of operations for output relay (operation rate max 1800 ops/hour)	
Mechanical	30'000'000
Electrical	100'000
<b>Auxiliary supply voltage 1 (<math>U_{AUX1}</math>)</b>	
Rated operational voltage ( $U_e$ )	24 V DC
Voltage operation range	+19...+33 V DC
Recommended safety equipment (1.0 A)	ABB Stotz-Kontakt GmbH S 271-K1
<b>Auxiliary supply voltage 2 (<math>U_{AUX2}</math>)</b>	
Rated operational voltage ( $U_e$ )	230 V AC
Rated operational voltage range ( $U_B$ )	0.85 x $U_{e\ min}$ ...1.1 x $U_{e\ max}$
Rated insulation voltage ( $U_i$ )	250 V AC
Rated frequency	50 / 60 Hz
Frequency limits	-5%...+3 %

**Notes:**

<b>Power consumption</b>	
Power consumption of U <sub>AUX1</sub>	
Typical	4.7 W
Maximum (MCU1)	7.2 W
Maximum (MCU2)	8.2 W
Power consumption of U <sub>AUX2</sub>	
Rated power	10 VA
Power consumption of voltage measurement	
400 VAC	1 V
690 VAC	2 V
<b>PTC</b>	
Minimum measured resistance	50 Ω
Maximum measured resistance	15 kΩ
Accuracy at 3600 Ω	± 10%
Accuracy at 1600 Ω	± 10%
Maximum current (at PTC sensor short circuit)	0,625 mA
Maximum power (at PTC sensor short circuit)	1.2 mW
Maximum voltage (at PTC sensor open circuit)	7.5 VDC
<b>Rotation monitoring</b>	
Auxiliary power supply (sensor)	24 V DC
Maximum sensor current, short circuit protected	32 mA
Maximum signal input current	30 mA
<b>Digital input</b>	
Number of digital input	
MCU1/MCU2	12 / 17
Number of general input	
MCU1/MCU2	- / 2
Closed contact current (peak)	2.6...10 mA
Open contact current (peak)	0...0.8 mA
Switch contact type selectable	NO (Normally Open) NC (Normally Closed)
Input read cycle	25 ms
<b>LED output</b>	
Number of LED output	
MCU1/MCU2	9 / 9
Output voltage	14.0 – 25 VDC
Output current (short circuit protected)	20...32 mA
<b>General purpose and watchdog output relay</b>	
Number of general output relay	
MCU1/MCU2	- / 2
Number of watchdog output relay	
MCU1/MCU2	1 / 1
Rated operational current	0.5 A
Rated operational voltage	24 VDC



# INSUM<sup>®</sup>

## MCU User's Guide

**Notes:**

### Analog output

Number of analog output MCU1/MCU2	- / 1
Max load	600 Ω
Selectable Range	0...20 mA or 4...20 mA
Selectable Full scale	1...8 x I <sub>n</sub>
Accuracy	± 2% of full scale

### Fieldbus interface

Protocol	LONWORKS
Transceiver type	FTT-10A
Transceiver bit rate	78 kbit/sec
Internal capacitor for protective shield connection	100 nF

### Environmental conditions

Ambient temperature range	
Storage	-25 – +85 °C
Normal operation	-5 – +55 °C

### Construction

Dimensions, mm	(W x H x D)
MCU1	110 x 145 x 65
MCU2 (incl. Voltage Unit)	110 x 145 x 103
Weight	
MCU1	0.9 kg
MCU2	1.4 kg
Protection Class	IP 20

Notes:

## 8 Standards and Approvals

### 8.1 Standards

**Table 80.** Standards.

IEC Publication 60947-1	"Low-voltage switchgear and controlgear" Part 1: General rules , Edition 2.2 1998-11
IEC Publication 60947-4-1	"Low-voltage switchgear and controlgear" Part 4: Contactors and motor –starters , First edition; 1990-07 Section One - Electromechanical contactors and motor-starters Amendment 1; 1994-11 Amendment 2; 1996-08
IEC Publication 60947-5-1	"Low-voltage switchgear and controlgear" Part 5: Control circuit devices and switching elements, First edition; 1990-03 Section One - Electromechanical control circuit devices Amendment 1; 1994-05Amendment 2; 1996-06

### 8.2 EMC compatibility

**Table 81.** Immunity tests.

Electrostatic discharge	EN 61000-4-2 (1995), Level 3
Electromagnetic field	EN 61000-4-3 (1996), Level 3 ENV 50204 (1995)
Fast transient bursts	EN 61000-4-4 (1995), Level 4
Surges ( 1,2/50 $\mu$ s - 8/20 $\mu$ s)	EN 61000-4-5 (1995), Level 3

**Table 82.** Emission tests.

Conducted radio-frequency emission tests	EN 55022 (1994), Class B
Radiated radio-frequency emission tests	EN 55022 (1994), Class B
Harmonic currents	EN 61000-3-2 (1995), Class A
Voltage fluctuation and flicker sensation	EN 61000-3-3 (1995)

### 8.3 EMC compatibility

**ATEX100a** (Physikalisch-Technische Bundesanstalt). For more information contact manufacturer.

Notes:

## Appendix A. Terminal descriptions

**Table 83.** Terminal descriptions for MCU1-4 and MCU2-4.

Terminal	Name	Description	MCU2 ONLY
L1	I1A	Motor phase L1 current input (window connection)	
L2	I2A	Motor phase L2 current input (window connection)	
L3	I3A	Motor phase L3 current input (window connection)	
T1	I1B	Motor phase L1 current output (window connection)	
T2	I2B	Motor phase L2 current output (window connection)	
T3	I3B	Motor phase L3 current output (window connection)	
X11:01	CCWDLI	Contactora control voltage input with watchdog relay	
X11:02	CCLI	Contactora control voltage input	
X11:03	NC	Not connected	
X11:04	CCA	Contactora control A	
X11:05	CCB	Contactora control B	
X11:06	CCC	Contactora control C	X
X12:01	SGBA	Switchgear bus (LON) line A	
X12:02	SGBB	Switchgear bus (LON) line B	
X12:03	SGBSHIELD	Switchgear bus shield (in-built capacitor)	
X13:01	CWDALA	Contactora watchdog signalling output, relay contact 1	
X13:02	CWDALB	Contactora watchdog signalling output, relay contact 2	
X13:03	GPO1	General purpose output relay 1	X
X13:04	GPOCOM	Common control voltage input	X
X13:05	GPO2	General purpose output relay 2	X
X13:06	RUNS1	LED output for motor running CW indication	
X13:07	RUNS2	LED output for motor running CCW indication	
X13:08	READY	LED output for ready to be started indication	
X13:09	ALARM	LED output for active alarm indication	
X13:10	TRIP	LED output for active trip indication	
X13:11	LOCAL	LED output for Local control indication	
X13:12	START1	Motor start 1 switch input (CW, Open)	
X13:13	START2	Motor start 2 switch input (CCW, Close)	
X13:14	STOP	Motor stop switch input	
X13:15	RESET	Trip reset switch input	
X13:16	LOCAL	Remote/local control switch input	
X13:17	EMSTOP	Auxiliary contact input from emergency stop switch	
X13:18	LIMIT1	Limit position switch 1 input	X
X13:19	LIMIT2	Limit position switch 2 input	X
X13:20	CFC	Contactora control C feedback input (drawer external)	X
X13:21	GPI1	General purpose input 1 (drawer external)	X
X13:22	GPI2	General purpose input 2 (drawer external)	X
X13:23	RTM	Rotation monitor input	X
X13:24	ANALOGOUT	Current signalling output	X
X13:25	UAUX1 (0 VDC)	UAUX1 input 0 VDC / Common	
X13:26	UAUX1 (0 VDC)	UAUX1 input 0 VDC	
X13:27	UAUX1 (+24 VDC)	UAUX1 input +24 VDC	

# INSUM<sup>®</sup>

## MCU User's Guide

**Notes:**

Terminal	Name	Description	MCU2 ONLY
X13:28	UAUX1 (+24 VDC)	UAUX1 input +24 VDC	
X13:29	IDCLOCK	Param. memory (MacSema ButtonMemoryR) CLK	X
X13:30	DGND	Param. memory (MacSema ButtonMemoryR) COM	X
X13:31	IDDATA	Param. memory (MacSema ButtonMemoryR) DATA	X
X13:32	24VDIGI	Common to drawer external I/O	
X13:33	I0A	Residual current transformer input A (drawer external)	X
X13:34	I0B	Residual current transformer input B (drawer external)	X
X14:01	TEST	Switch disconnecter "Test" input and LON "Service" input	
X14:02	SD	Switch disconnecter 0/1 position input	
X14:03	EXTRIP	External trip input	
X14:04	24VDIGI	Common to drawer internal I/O	
X14:05	24VDIGI	Common to drawer internal I/O	
X14:06	MCB	Auxiliary contact from miniature circuit breaker	
X14:07	CFA	Contact control A feedback input	
X14:08	CFB	Contact control B feedback input	
X14:09	CFC	Contact control C feedback input (drawer internal)	X
X14:10	GPI1	General purpose input 1 (drawer internal)	X
X14:11	GPI2	General purpose input 2 (drawer internal)	X
X14:12	NC	Not connected	
X14:13	I0A	Residual current transformer input A (drawer internal)	X
X14:14	I0B	Residual current transformer input B (drawer internal)	X
X15:01	NC	Not connected	
X15:02	NC	Not connected	
X15:03	DFP_RUNS	LED output for running CW/CCW indication	
X15:04	DFP_READY	LED output for ready to be started indication / Wink indication	
X15:05	DFP_TRIP	LED output for active trip indication	
X15:06	0VDC	Common to drawer front panel LED output	
X16:01	NC	Not connected	
X16:02	PTCA	PTC measurement input A	X
X16:03	PTCB	PTC measurement input B	X
X16:04	NC	Not connected	
X17:01	MVML1	Motor phase L1 voltage input	X
X17:02	MVML2	Motor phase L2 voltage input	X
X17:03	MVML3	Motor phase L3 voltage input	X
X18:01	U <sub>AUX2</sub> (L)	U <sub>AUX2</sub> input L (power supply through voltage unit)	X
X18:02	U <sub>AUX2</sub> (N)	U <sub>AUX2</sub> input N (power supply through voltage unit)	X
-	CHASSIS	Device ground connection	

**Notes:**

**Picture 57. Terminals for MCU1-4 and MCU2-4.**

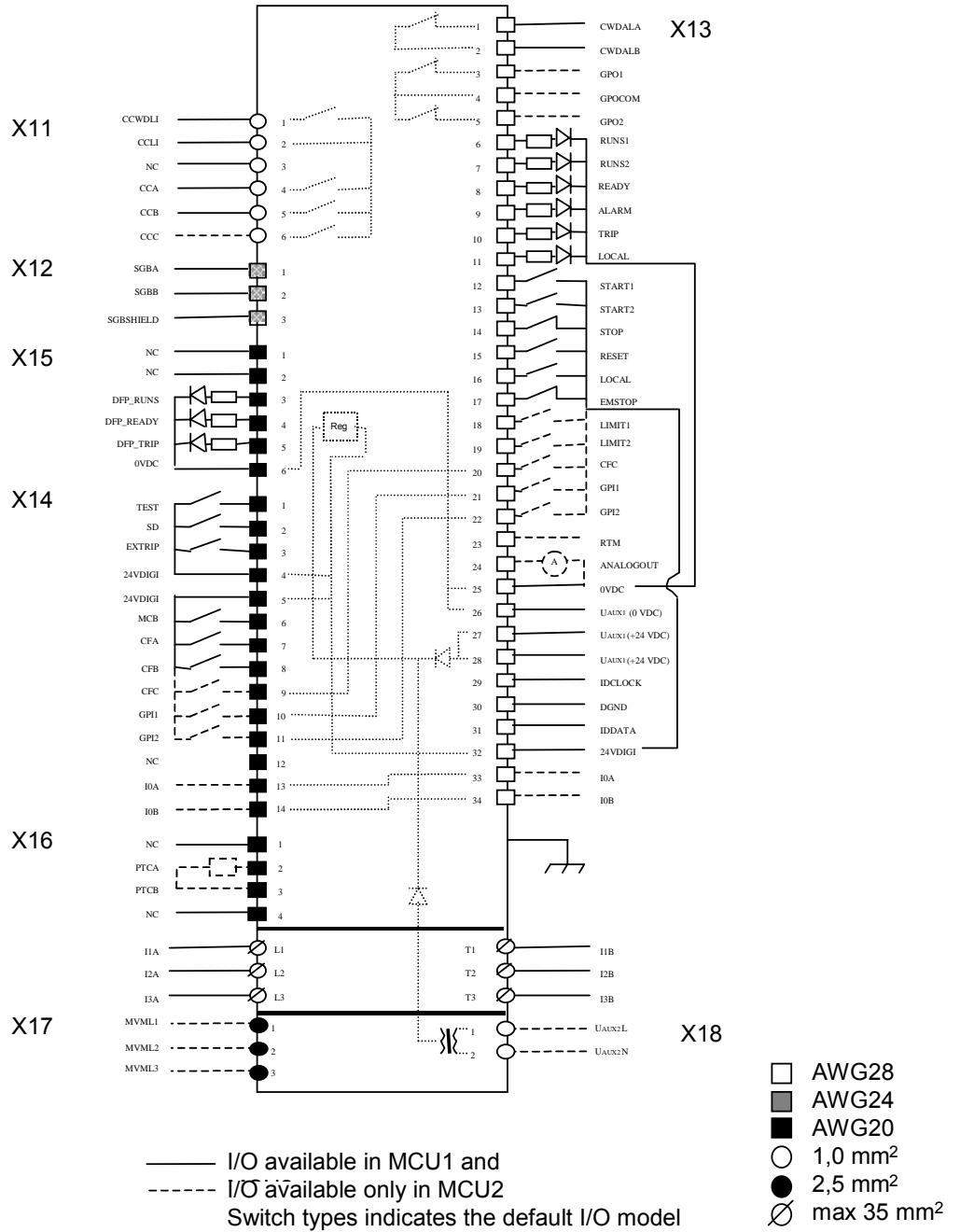

Notes:

## Appendix B. Parametering failure codes

**Table 84.** Codes and source of parametering failure.

ID / value	Function	Parameter Name	Explanation
001	System	Status heartbeat	Value out of range
002	System	NV heartbeat base	Value out of range
003	Starter configuration	Em-stop reset mode	Invalid value
008	Starter configuration	External CT2 primary	Value out of range
009	Starter configuration	External CT1 primary	Value out of range
010	Starter configuration	External CT secondary	Value out of range
011	Starter configuration	Nominal current	Value out of range
012	Starter configuration	Startup I ratio	Value out of range
013	Starter configuration	Nominal current N2	Value out of range
014	Starter configuration	Startup I ratio N2	Value out of range
015	System	I report deadband	Value over range
016	Starter configuration	Number of phases	Invalid value
018	Thermal Overload Protection	Trip reset mode	Invalid value
021	Thermal Overload Protection	TOL alarm level	Value out of range
023	Thermal Overload Protection	Trip class (t6)	Value out of range
024	Thermal Overload Protection	Cool down time factor	Value out of range
025	Thermal Overload Protection	Ia/In Ratio	Value out of range
026	Thermal Overload Protection	Trip class (te)	Value over range
027	Starter configuration	Feedback delay	Value over range
029	Thermal Overload Protection	Trip class (t6) N2	Value out of range
031	Thermal Overload Protection	Ia/In ratio N2	Value out of range
032	Thermal Overload Protection	Trip class (te) N2	Value over range
033	Phase Loss Protection	Alarm level	Value out of range
034	Phase Loss Protection	Trip level	Value out of range
035	Phase Loss Protection	Trip delay	Value over range
036	Underload Protection	Alarm level	Value out of range
037	Underload Protection	Trip level	Value out of range
038	Underload Protection	Trip delay	Value over range
039	No Load Protection	Alarm level	Value out of range
040	No Load Protection	Trip level	Value out of range
041	No Load Protection	Trip delay	Value over range
042	Stall Protection	Alarm level	Value out of range
043	Stall Protection	Trip level	Value out of range
044	Stall Protection	Trip delay	Value over range
045	Earth Fault Protection	Alarm level	Value over range
046	Earth Fault Protection	Trip level	Value over range
047	Earth Fault Protection	Trip delay	Value over range
049	Earth Fault Protection	Residual CT primary	Invalid value
050	Unbalance Protection	Alarm level	Value out of range
051	Unbalance Protection	Trip level	Value out of range
052	Unbalance Protection	Trip delay	Value over range
053	Underload Cosphi Protection	Alarm level	Value out of range

# INSUM<sup>®</sup>

## MCU User's Guide

### Notes:

ID / value	Function	Parameter Name	Explanation
054	Underload Cosphi Protection	Trip level	Value over range
055	Underload Cosphi Protection	Trip delay	Value over range
058	Rotation Monitor Protection	Trip delay	Value over range
060	PTC Protection	Alarm level	Value out of range
061	Thermal Overload Protection	Thermal model	PTC must be enabled with EExe
064	PTC Protection	Short circuit trip level	Value out of range
065	Undervoltage Protection	Alarm level	Value out of range
066	Undervoltage Protection	Trip level	Value out of range
067	Undervoltage Protection	Trip delay	Value out of range
068	Undervoltage Protection	Reset voltage level	Value out of range
069	Undervoltage Protection	Max. power down time	Value over range
070	Undervoltage Protection	Staggered start time	Value over range
071	Start Limitation Protection	Time interval	Value over range
072	Start Limitation Protection	Number of starts	Value out of range
075	Starter configuration	Failsafe status	Status not valid for starter type
076	Starter configuration	Failsafe timeout	Value out of range
077	Starter configuration	Starter type	Invalid value
078	Starter configuration	Motor startup time	Value over range
079	Starter configuration	Motor startup time N2	Value over range
080	Starter configuration	Motor ambient temperature	Value out of range
081	Maintenance Functions	Motor hours run alarm	Value out of range
082	Starter configuration	S/D changeover current	Value out of range
084	Starter configuration	Softstart ramp time	Value over range
085	Starter configuration	Softstop ramp time	Value over range
086	Starter configuration	Autotrafo start time	Value over range
091	Motor Grouping	Group start direction	Invalid value
092	Motor Grouping	Group start delay	Value over range
093	Motor Grouping	Group stop delay	Value over range
094	Undervoltage	Nominal voltage	Value out of range
097	Maintenance Functions	CCa cycles alarm level	Value out of range
098	Maintenance Functions	CCb cycles alarm level	Value out of range
099	Maintenance Functions	CCc cycles alarm level	Value out of range
100	System	SU lifelist timeout	Value out of range
103	General Purpose I/O	GpO1 ON value	Value over range
104	General Purpose I/O	GpO1 OFF value	Value over range
105	General Purpose I/O	GpO2 ON value	Value over range
106	General Purpose I/O	GpO2 OFF value	Value over range
107	General Purpose I/O	GpI1 ON value	Value over range
108	General Purpose I/O	GpI1 OFF value	Value over range
109	General Purpose I/O	GpI2 ON value	Value over range
110	General Purpose I/O	GpI2 OFF value	Value over range
122	Undervoltage	Max. autoreclose time	Value over range
123	Starter configuration	MCB reset mode	Invalid value

# INSUM<sup>®</sup>

## MCU User's Guide

**Notes:**

ID / value	Function	Parameter Name	Explanation
124	Starter configuration	External trip reset mode	Invalid value
125	PTC Protection	Cable compensation	Value over range
126	Undervoltage Protection	External VT installed	Invalid value
127	Undervoltage Protection	External VT secondary	Value out of range
128	Undervoltage Protection	External VT primary	Value out of range
129	Start Interlock Protection	Interlock time	Value over range
150	Device data	Internal CT range	Nominal current does not match range
151	Analog output	Full range	Out of full range
152	Analog output	Scaling	Out of scale
160	Device data	Internal VT sensor	No unit, but undervoltage prot. in use
161	Device data	Internal VT sensor	No unit, but cosphi prot. in use
162	Starter type	Thermal model	EExe without ambient temp. 40°C
163	Starter type	Thermal model	EExe without TOL enabled
164	Starter type	Thermal model	EExe without phase loss protection enabled
165	Starter type	Thermal model	EExe without unbalance protection enabled
166	Starter configuration	Number of phases	Single ph. without phase unbalance disabled



Notes:

## Appendix C. MCU1 and MCU2 digital input configuration

**Table 85.** Digital input configuration

Input	Parameter = 'NO'	Parameter = 'NC'	Def	Bit
X13:12 START1	Motor starts to direction 1 when contact closed.	Motor starts to direction 1 when contact opened.	NO	0
X13:13 START2	Motor starts to direction 2 when contact closed.	Motor starts to direction 2 when contact opened.	NO	1
X13:14 STOP	Motor stops when contact closed.	Motor stops when contact opened.	NC	2
X13:15 RESET	Trip reset executes when contact closed.	Trip reset executes when contact opened.	NO	3
X13:16 LOCAL	Local control activates when contact closed.	Local control activates when contact opened.	NO	4
X13:17 EMSTOP	Emergency Stop trip executes when contact closed.	Emergency Stop trip activates when contact opened.	NC	5
X14:1 TEST	Test position activates when contact is closed.	Test position activates when contact is opened.	NO	6
X14:2 SD	Main Switch is OFF when contact is closed.	Main Switch is OFF when contact is opened.	NO	7
X14:6 MCB	MCB Trip executes when contact closed.	MCB Trip executes when contact opened.	NO	8
X14:7 CFA	Contactora state is closed when contact is closed.	Contactora state is closed when contact is opened.	NO	9
X14:8 CFB	Contactora state is closed when contact is closed.	Contactora state is closed when contact is opened.	NO	10
X14:3 SDRI	SDR Trip executes when contact closed.	SDR Trip executes when contact opened.	NO	11
X14:9 CFC / Torque	Contactora state is closed when contact is closed.	Contactora state is closed when contact is opened.	NO	12
X13:18 Limit1	Limit1 position activates when contact closed.	Limit1 position activates when contact opened.	NO	13
X13:9 Limit2	Limit2 position activates when contact closed.	Limit2 position activates when contact opened.	NO	14
X13:23 RTM	RTM input activates when contact is closed.	RTM input activates when contact is opened.	NO	15

Notes:

## Appendix D. MCU SW and HW functional reference guide

**Table 86.** Software functions for MCU1 and MCU2.

Function Group	Functionality	Unit	Remarks
1.0	Protection function		
1.1	Thermal protection (TOL)		
1.2	Standard	MCU1/ 2	
1.3	EEx e	MCU2	
1.4	Phase loss protection	MCU1/ 2	
1.5	No load protection	MCU1/ 2	
1.6	Stall protection	MCU1/ 2	
1.7	Underload protection	MCU1/ 2	
1.8	Unbalance protection	MCU2	
1.9	Undervoltage protection	MCU2	with Voltage Unit
1.10	Rotation monitor	MCU2	Rotation monitor as binary input
1.11	PTC protection	MCU2	
1.12	Earthfault protection	MCU2	
1.13	Start limitation protection	MCU2	
1.14	Start interlock protection	MCU2	
1.15	Underload cosphi protection	MCU2	with Voltage Unit
2.0	Starter type		
2.1	NR-DOL	MCU1/ 2	Latched and softstarter options
2.2	REV-DOL	MCU1/ 2	Latched and softstarter options
2.3	NR-DOL/RCU	MCU1/ 2	
2.4	REV-DOL/RCU	MCU2	
2.5	NR-Star/Delta	MCU2	
2.6	REV-Star/Delta	MCU2	
2.7	NR-2N	MCU2	
2.8	REV-2N	MCU2	
2.9	Actuator	MCU2	10 configurations available
2.10	Autotransformer	MCU2	
3.0	Other functions		
3.1	Failsafe functionality	MCU1/ 2	
3.2	Watchdog functionality	MCU1/ 2	
3.3	Remote / local control	MCU1/ 2	
3.4	Real time clock	MCU1/ 2	
3.5	External trip (virtual input)	MCU1/ 2	
3.6	General purpose I/O	MCU1/ 2	
3.7	Feedback supervision	MCU2	
3.8	Analog output	MCU1/ 2	

# INSUM<sup>®</sup>

## MCU User's Guide

**Notes:**

Function Group	Functionality	Unit	Remarks
4.0	Reporting/ supervision		
4.1	Phase currents (abs/rel)	MCU1/ 2	
4.2	Number of contactor cycles	MCU1/ 2	
4.3	Motor running hours	MCU1/ 2	
4.4	Calculated thermal capacity	MCU1/ 2	
4.5	Time to trip	MCU1/ 2	
4.6	Time to reset	MCU1/ 2	
4.7	Alarm/ event reporting	MCU1/ 2	Time tagged alarm/event messages
4.8	Voltage reporting	MCU2	with Voltage Unit
4.9	Power factor	MCU2	with Voltage Unit
4.10	Active power	MCU2	with Voltage Unit
4.11	Reactive power	MCU2	with Voltage Unit
4.12	Earth fault current	MCU2	
4.13	Frequency	MCU2	with Voltage Unit

**Notes:**

**Table 87.** Hardware functions for MCU1 and MCU2.

Function Group	Functionality	Unit	Remarks
1.0	Output relay		
1.1	CCA, CCB	MCU1/ 2	
1.2	CCC	MCU2	
1.3	GPO1, _2	MCU2	General purpose output
2.0	Led output		
2.1	Runs1	MCU1/ 2	
2.2	Runs2	MCU1/ 2	
2.3	Ready	MCU1/ 2	
2.4	Tripped	MCU1/ 2	
2.5	Alarm	MCU1/ 2	
2.6	Local	MCU1/ 2	
2.7	DFP_runs, _ready, _trip	MCU1/ 2	
3.0	Control input		
3.1	Local	MCU1/ 2	
3.2	Reset	MCU1/ 2	
3.3	Start1	MCU1/ 2	
3.4	Start2	MCU1/ 2	
3.5	Stop	MCU1/ 2	
3.6	Emstop	MCU1/ 2	
3.7	Test	MCU1/ 2	
3.8	SD	MCU1/ 2	
3.9	Trip	MCU1/ 2	
3.10	MCB	MCU1/ 2	
3.11	CFA, _B	MCU1/ 2	
3.12	CFC	MCU2	
3.13	GPI1, _2	MCU2	General purpose input
3.14	RTM input	MCU2	Binary input for rotation sensor
4.0	Control output		
4.1	Analog output	MCU2	
5.0	Measurement input		
5.1	Current input	MCU1/ 2	Three phase currents
5.2	Voltage input	MCU2	Three phase voltages, with VU
5.3	PTC input	MCU2	
5.4	RCT input	MCU2	Residual current transformer (earth fault current)
6.0	Fieldbus interface		
6.1	LONWORKS	MCU1/ 2	FTT-10A transceiver
6.0	Watchdog relay		
6.1	CCWDLI	MCU1/ 2	Input for contactor control relay
6.2	Watchdog signal	MCU1/ 2	Signalling output
7.0	Power supply		
7.1	Uaux1	MCU1/ 2	+24 VDC auxiliary power supply
7.2	Uaux2	MCU2	230 VAC auxiliary power supply, with Voltage Unit

Notes:

## Appendix E. List of Pictures and Tables

### List of pictures

<b>Picture 1.</b>	MCU2 with voltage unit.	6
<b>Picture 2.</b>	INSUM system configuration with Motor Control Units (MCU).	6
<b>Picture 3.</b>	Connectors on the bottom of the MCU and the Voltage unit.	9
<b>Picture 4.</b>	Connectors on the side of the unit.	9
<b>Picture 5.</b>	Connection of the rotation monitor sensor.	15
<b>Picture 6.</b>	Fieldbus cable shield and fieldbus connector.	16
<b>Picture 7.</b>	Contactors control wiring for NR-DOL starter, MCU1 and MCU2.	21
<b>Picture 8.</b>	Contactors control wiring for REV-DOL starter, MCU1 and MCU2.	21
<b>Picture 9.</b>	Control circuit for latched NR-DOL with normal contactors, MCU2.	22
<b>Picture 10.</b>	Control circuit for latched REV-DOL with normal contactors, MCU2.	23
<b>Picture 11.</b>	Control circuit for latched NR-DOL, mechanical latched contactor.	23
<b>Picture 12.</b>	Control circuit for latched NR-DOL, magnetic latched contactor.	23
<b>Picture 13.</b>	Control circuit with softstarter for NR-DOL, MCU2.	24
<b>Picture 14.</b>	Control circuit with softstarter for REV-DOL, MCU2.	24
<b>Picture 15.</b>	Control circuit with softstarter for NR-DOL, latched contactors.	25
<b>Picture 16.</b>	Control circuit with softstarter for REV-DOL, latched contactors.	25
<b>Picture 17.</b>	Start sequences for softstarter with delay times.	26
<b>Picture 18.</b>	Stop sequences for softstarter with delay times.	26
<b>Picture 19.</b>	Control circuit for NR-DOL/RCU starter for MCU1.	27
<b>Picture 20.</b>	Control circuit for NR-DOL/RCU starter for MCU2.	27
<b>Picture 21.</b>	Control circuit for REV-DOL/RCU starter, MCU2.	28
<b>Picture 22.</b>	Control circuit for NR-S/D starter, MCU2.	29
<b>Picture 23.</b>	NR-S/D switching over parameters, principle picture.	30
<b>Picture 24.</b>	Control circuit for REV-S/D starter, MCU2.	31
<b>Picture 25.</b>	Control circuit for NR-2N starter, Dahlander, MCU2.	32
<b>Picture 26.</b>	Control circuit for NR-2N with two contactors, separate windings, MCU2.	32
<b>Picture 27.</b>	External current transformer connection for NR-2N to MCU2 unit.	33
<b>Picture 28.</b>	Control circuit for REV-2N starter, reversing Dahlander.	35
<b>Picture 29.</b>	Control circuit for REV-2N starter with separate windings.	35
<b>Picture 30.</b>	Control circuit for Actuator starter with limit switches, MCU2.	36
<b>Picture 31.</b>	Control circuit for Actuator starter with torque switch, MCU2.	36
<b>Picture 32.</b>	Control circuit for autotransformer starter, example 1, MCU2.	38
<b>Picture 33.</b>	Control circuit for autotransformer starter, example 2.	38
<b>Picture 34.</b>	Control circuit for autotransformer starter, example 3.	38
<b>Picture 35.</b>	Principle picture of motor thermal simulation.	40
<b>Picture 36.</b>	Startup inhibit level functionality.	44
<b>Picture 37.</b>	Thermal protection trip functionality (trip reset level, $\theta_s$ ).	44
<b>Picture 38.</b>	TOL alarm indication ( <i>TOL alarm level</i> , $\theta_{al}$ and alarm reset, $\theta_{al\ reset}$ ).	45
<b>Picture 39.</b>	Thermal protection overload alarm indication.	45
<b>Picture 40.</b>	Thermal level increase during motor operating condition.	46
<b>Picture 41.</b>	Cooling down for a stopped or running motor.	46
<b>Picture 42.</b>	Thermal simulation principle for two speed motor.	48
<b>Picture 43.</b>	MCU phase current loss protection.	48
<b>Picture 44.</b>	MCU underload protection.	49
<b>Picture 45.</b>	Underload cosphi protection.	50
<b>Picture 46.</b>	MCU no load protection.	50
<b>Picture 47.</b>	MCU stall protection.	51
<b>Picture 48.</b>	MCU2 earth fault protection.	52
<b>Picture 49.</b>	MCU2 unbalance protection.	53
<b>Picture 50.</b>	MCU2 rotation monitor protection.	53
<b>Picture 51.</b>	Thermal protection with PTC.	54
<b>Picture 52.</b>	Undervoltage protection function.	55
<b>Picture 53.</b>	Start limitation for <i>Number of starts 3</i> within <i>Time interval</i> .	56
<b>Picture 54.</b>	Start interlock operation principle.	57
<b>Picture 55.</b>	Contactors operation within <i>Feedback delay</i> .	58
<b>Picture 56.</b>	INSUM time synchronization.	63
<b>Picture 57.</b>	Terminals for MCU1–4 and MCU2-4.	75

# INSUM<sup>®</sup>

## MCU User's Guide

### Notes:

### List of Tables

<b>Table 1.</b>	MCU hardware –4 type designation	7
<b>Table 2.</b>	Device connectors.	8
<b>Table 3.</b>	Recommended plugs and cables.	8
<b>Table 4.</b>	Auxiliary supply voltage ranges ( $U_{AUX1}$ and $U_{AUX2}$ ) and options.	10
<b>Table 5.</b>	Auxiliary power supply input connectors and pins.	10
<b>Table 6.</b>	Power consumption calculation (maximum steady state consumption).	10
<b>Table 7.</b>	Digital input connectors and pins.	11
<b>Table 8.</b>	LED output connectors and pins.	12
<b>Table 9.</b>	LED output functionality.	12
<b>Table 10.</b>	Contactors watchdog signalling connectors and pins.	13
<b>Table 11.</b>	Contactors control connectors and pins.	13
<b>Table 12.</b>	General purpose digital input connectors and pins.	14
<b>Table 13.</b>	General purpose digital output connectors and pins.	14
<b>Table 14.</b>	General purpose digital output connectors and pins.	14
<b>Table 15.</b>	Rotation monitor connectors and pins.	15
<b>Table 16.</b>	PTC input connectors and pins.	15
<b>Table 17.</b>	Fieldbus interface connectors and pins.	15
<b>Table 18.</b>	Residual current transformer connectors and pins.	16
<b>Table 19.</b>	RCT type information.	16
<b>Table 20.</b>	Burden resistor values with residual current transformer.	16
<b>Table 21.</b>	Current measurement and internal current ranges.	17
<b>Table 22.</b>	Recommended intermediate transformer's type and code.	17
<b>Table 23.</b>	Voltage measurement connectors and pins.	17
<b>Table 24.</b>	Starter types for MCU1 and MCU2.	19
<b>Table 25.</b>	NR-DOL starter contactor control interface.	20
<b>Table 26.</b>	REV-DOL starter contactor control interface.	21
<b>Table 27.</b>	Latched contactor control interface.	22
<b>Table 28.</b>	Softstarter parameters.	25
<b>Table 29.</b>	NR-DOL/RCU starter contactor control interface.	26
<b>Table 30.</b>	REV-DOL/RCU starter contactor control interface.	28
<b>Table 31.</b>	NR-S/D starter contactor control interface.	29
<b>Table 32.</b>	Parameters for selecting change over condition.	29
<b>Table 33.</b>	REV-S/D starter contactor control interface.	31
<b>Table 34.</b>	NR-2N starter contactor control interface.	32
<b>Table 35.</b>	REV-2N starter contactor control interface.	34
<b>Table 36.</b>	Actuator starter contactor control interface.	35
<b>Table 37.</b>	Active limit switch and event message.	36
<b>Table 38.</b>	Possible configurations for limit and torque switch operation.	37
<b>Table 39.</b>	Autotransformer starter contactor control interface.	37
<b>Table 40.</b>	Disabled protection during following conditions.	39
<b>Table 41.</b>	Protection function set according to variation.	40
<b>Table 42.</b>	Occurrence of abbreviations.	41
<b>Table 43.</b>	Motor Control Unit parameters.	42
<b>Table 44.</b>	IEC 60947-4-1 trip class when ambient temp. 40°C, balanced motor current.	43
<b>Table 45.</b>	Phase loss protection parameters.	48
<b>Table 46.</b>	Underload protection parameters.	49
<b>Table 47.</b>	Underload cosphi protection parameters.	49
<b>Table 48.</b>	No load protection parameters.	50
<b>Table 49.</b>	Stall protection function parameters.	51
<b>Table 50.</b>	Earth fault protection parameters.	52
<b>Table 51.</b>	Unbalance protection parameters.	52
<b>Table 52.</b>	Rotation monitor parameters.	53
<b>Table 53.</b>	Thermal protection parameters.	54
<b>Table 54.</b>	Undervoltage protection function parameters.	55
<b>Table 55.</b>	Start limitation parameters.	56
<b>Table 56.</b>	Start limitation parameters.	57
<b>Table 57.</b>	Feedback supervision input connectors and pins.	58
<b>Table 58.</b>	Feedback delay range.	58
<b>Table 59.</b>	Truth table of the contactor supervision in the normal mode.	59
<b>Table 60.</b>	Truth table of the contactor supervision in the test mode.	59
<b>Table 61.</b>	Truth table for contactor CCB (/CCC), NR-DOL/RCU mode only.	59
<b>Table 62.</b>	Main switch test input connectors and pins.	60
<b>Table 63.</b>	Miniature circuit breaker input connectors and pins.	60
<b>Table 64.</b>	Emergency stop input connectors and pins.	60
<b>Table 65.</b>	External trip input connectors and pins.	60
<b>Table 66.</b>	External trip network variable input.	60
<b>Table 67.</b>	Main switch input connectors and pins.	61
<b>Table 68.</b>	General purpose input connectors and pins.	61
<b>Table 69.</b>	General purpose input connectors and pins.	61
<b>Table 70.</b>	General purpose output connectors (Conn) and terminals (Term).	61
<b>Table 71.</b>	General purpose network variable inputs.	61
<b>Table 72.</b>	Network variable output for contactor switch cycle reporting.	62

---

# INSUM<sup>®</sup>

## MCU User's Guide

---

**Notes:**

<b>Table 73.</b>	Network variable output for contactor switch cycle reporting.	62
<b>Table 74.</b>	Network variables for failsafe function.	62
<b>Table 75.</b>	Network variables for time synchronization.	63
<b>Table 76.</b>	The following events are sent for an indication of time stamp validity.	63
<b>Table 77.</b>	Remote/local control input connectors and pins.	64
<b>Table 78.</b>	Remote/local network variable input.	64
<b>Table 79.</b>	Background update cycle defined by NV heartbeat base (T) parameter.	66
<b>Table 80.</b>	Standards.	72
<b>Table 81.</b>	Immunity tests.	72
<b>Table 82.</b>	Emission tests.	72
<b>Table 83.</b>	Terminal descriptions for MCU1-4 and MCU2-4.	73
<b>Table 84.</b>	Codes and source of parametering failure.	76
<b>Table 85.</b>	Digital input configuration	79
<b>Table 86.</b>	Software functions for MCU1 and MCU2.	80
<b>Table 87.</b>	Hardware functions for MCU1 and MCU2.	82

Notes:

## Appendix F. Terms and Abbreviations

Abbreviation	Term	Explanation / Comments
	Alarm	Alarm is defined as status transition from any state to abnormal state. Status transition to abnormal state can be data crossing over the predefined alarm limit.
	Backplane	INSUM backbone, holds following INSUM devices: router, gateways, clock, power supply. Part of the INSUM Communication Unit, see ICU
CA	Control Access	A function of INSUM system that allows definition of operating privileges for each device level (e.g. PCS, gateway, field device)
CAT	Control Access Table	Table containing control access privileges
CB	Circuit Breaker	Circuit breaker unit (here: ABB SACE Emax with electronic release PR112-PD/LON)
CT	Current Transformer	Current Transformer
DCS	Distributed Control System	see also PCS
Eth	Ethernet	Layer 1 of the ISO layer model for networks, describing the physical properties (cable, connectors etc.) using TCP/IP protocol
	Event	An event is a status transition from one state to another.  It can be defined as alarm, if the state is defined as abnormal or as warning as a pre-alarm state.
FD	Field Device	Term for devices connected to the LON fieldbus (e.g. motor control units or circuit breaker protection)
FU	Field Unit	see Field Device
GPI	General Purpose Input	Digital input on MCU for general use
GPO	General Purpose Output	Digital output on MCU for general use
GPS	Global Positioning System	System to detect local position, universal time and time zone, GPS technology provides accurate time to a system
GW	Gateway	A gateway is used as an interface between LON protocol in INSUM and other communication protocols (e.g. TCP/IP, Profibus, Modbus)
HMI	Human Machine Interface	Generic expression for switchgear level communication interfaces to field devices, either switchboard mounted or hand held
ICU	INSUM Communications Unit	INSUM Communications Unit consists of devices such as backplane, gateways, routers, system clock and power supply. It provides the communication interface within INSUM and between INSUM and control systems.  Formerly used expressions: SGC, SU
INSUM	INSUM	Integrated System for User optimized Motor Management. The concept of INSUM is to provide a platform for integration of smart components, apparatus and software tools for engineering and operation of the motor control switchgear
INSUM OS	INSUM Operator Station	Tool to parameterise, monitor and control devices in the INSUM system
ITS	Integrated Tier Switch	The Intelligent Tier Switch is an ABB SlimLine switch fuse with integrated sensors and microprocessor based electronics for measurement and surveillance
LON	Local Operating Network	LON is used as an abbreviation for LonWorks network. A variation of LON is used as a switchgear bus in the INSUM 2 system



**Notes:**

Abbreviation	Term	Explanation / Comments
LonTalk	LonTalk protocol	Fieldbus communication protocol used in LonWorks networks
LonWorks	LonWorks network	A communication network built using LonWorks network technology, including e.g. Neuron chip and LonTalk protocol
MCU	Motor Control Unit	Motor Control Unit is a common name for a product range of electronic motor controller devices (field device) in INSUM. A MCU is located in a MNS motor starter, where its main tasks are protection, control and monitoring of motor and the related motor starter equipment.
MMI	Man Machine Interface	The switchgear level INSUM HMI device to parameterize and control communication and field devices.
MNS	MNS	ABB Modular Low Voltage Switchgear
	Modbus, Modbus RTU	Fieldbus communication protocol
NV,nv	LON Network Variable	Network variable is a data item in LonTalk protocol application containing max. 31 bytes of data.
Nvi, nvi	LON Network Variable input	LON bus input variable
Nvo, nvo	LON Network Variable output	LON bus output variable
OS	Operator Station	see INSUM OS
PCS	Process Control System	High level process control system
PLC	Programmable Local Controller	Low level control unit
PR	Programmable Release	Circuit breaker protection/release unit (here: ABB SACE Emax PR112-PD/LON)
	Profibus DP	Fieldbus communication protocol with cyclic data transfer
	Profibus DP-V1	Fieldbus communication protocol, extension of Profibus DP allowing acyclic data transfer and multi master.
PTB	Physikalisch-Technische Bundesanstalt	Authorized body in Germany to approve Ex-e applications.
PTC	Positive Temperature Coefficient	A temperature sensitive resistor used to detect high motor temperature and to trip the motor if an alarm level is reached.
RCU	Remote Control Unit	Locally installed control device for motor starter, interacting directly with starter passing MCU for local operations.
	Router	Connection device in the LON network to interconnect different LON subnets. Part of the INSUM Communications Unit.
RTC	Real Time Clock	Part of the INSUM System Clock and and optionally time master of the INSUM system
SCADA	Supervisory Control and Data Acquisition	
SGC	Switchgear Controller	Former term used for INSUM Communications Unit
SU	Switchgear Unit	Former term used for INSUM Communications Unit
	System Clock	INSUM device providing time synchronisation between a time master and all MCUs. Part of the INSUM Communication Unit, see ICU
TCP/IP	Transmission Control Protocol / Internet Protocol	Transmission protocol used for data transmission via Ethernet
TFLC	Thermal Full Load Current	See MCU Parameter Description for explanation
TOL	Thermal Overload	See MCU Parameter Description for explanation

# INSUM<sup>®</sup>

## MCU User's Guide

### Notes:

Abbreviation	Term	Explanation / Comments
	Trip	A consequence of an alarm activated or an external trip command from another device to stop the motor or trip the circuit breaker.
VU	Voltage Unit	Voltage measurement and power supply unit for MCU 2
	Wink	The Wink function enables identification of a device on the LON network. When a device receives a Wink-message via the fieldbus, it responds with a visual indication (flashing LED)





---

**ABB Automation Products GmbH**  
Wallstadter Str. 59  
D - 68526 Ladenburg / Germany

Editor: DEAPR/S-RD  
Publication no: 1TGC901022M0201

Related Products, News, Local Contacts:  
**[www.abb.com/mns](http://www.abb.com/mns)**