

Machine Terminal REM 54_

Technical Reference Manual, General



Contents

1. About this manual	7
1.1. Copyrights	7
1.2. Trademarks	7
1.3. Guarantee	7
1.4. This manual	7
1.5. Use of symbols	7
1.6. Related documents	8
1.7. Document revisions	9
2. Safety information	10
3. Introduction	11
3.1. General	11
3.2. Hardware versions	11
4. Instructions	20
4.1. Application	20
4.2. Requirements	21
4.3. Configuration	22
5. Technical Description	23
5.1. Functional description	23
5.1.1. Functions of the machine terminal	23
5.1.1.1. Protection functions	23
5.1.1.2. Measurement functions	25
5.1.1.3. Control functions	25
5.1.1.4. Condition monitoring functions	27
5.1.1.5. Communication functions	27
5.1.1.6. General functions	27
5.1.1.7. Standard functions	28
5.1.2. Configuration	30
5.1.2.1. Machine terminal configuration	30
5.1.2.2. MIMIC configuration	31
5.1.2.3. LON network configuration	32
5.1.2.4. Modbus configuration	33
5.1.2.5. Rated frequency	33
5.1.3. Parameters and events	33
5.1.4. Parameterization	33
5.1.4.1. Local parameterization	33
5.1.4.2. External parameterization	34
5.1.4.3. Storing of parameters and recorded data	34
5.1.5. Auxiliary voltage	35
5.1.5.1. Power supply versions	35

5.1.5.2.	Low auxiliary voltage indication	36
5.1.5.3.	Overtemperature indication	36
5.1.6.	Analog channels	37
5.1.6.1.	Scaling the rated values of the protected unit for analog channel	40
5.1.6.2.	Technical data of the measuring devices	41
5.1.6.3.	Calculated analog channels	43
5.1.7.	Digital inputs	43
5.1.7.1.	Filter time of a digital input	45
5.1.7.2.	Inversion of a digital input	45
5.1.7.3.	Pulse counters	46
5.1.7.4.	Oscillation suppression	47
5.1.7.5.	Attributes of a digital input for machine terminal configuration	47
5.1.8.	Digital outputs	48
5.1.8.1.	High-speed double-pole power outputs (HSPO)	49
5.1.8.2.	Single-pole power outputs (PO)	50
5.1.8.3.	Double-pole power outputs (PO)	50
5.1.8.4.	Signal outputs (SO)	51
5.1.9.	RTD/analog inputs	52
5.1.9.1.	Selection of input signal type	52
5.1.9.2.	Selection of input signal range	52
5.1.9.3.	Transducer supervision	54
5.1.9.4.	Signal filtering	54
5.1.9.5.	Input scaling/linearization	54
5.1.9.6.	Transducer connections	55
5.1.9.7.	Attributes of an RTD/analog input for machine terminal configuration	57
5.1.9.8.	RTD/analog input configuration example	58
5.1.9.9.	Self-supervision	58
5.1.9.10.	Calibration	59
5.1.9.11.	RTD temperature vs. resistance	60
5.1.10.	Analog outputs	61
5.1.10.1.	Selection of analog output range	61
5.1.10.2.	Attributes of an analog output for machine terminal configuration	61
5.1.10.3.	Analog output configuration example	62
5.1.11.	Trip circuit supervision	63
5.1.11.1.	Configuring the trip circuit supervision CMTCS_	64
5.1.12.	Self-supervision (IRF)	65
5.1.12.1.	Fault indication	65

5.1.12.2. Fault codes	65
5.1.13. Serial communication	66
5.1.13.1. Serial communication port assignment	66
5.1.13.2. SPA/Modbus communication on the rear connector X3.2	66
5.1.13.3. IEC 61850 communication by using SPA-ZC 400 on the rear connector X3.2	67
5.1.13.4. Profibus-DPV1 communication by using SPA-ZC 302 on the rear connector X3.2	67
5.1.13.5. LON/SPA bus communication on the rear connector X3.3	67
5.1.13.6. Front panel optical RS-232 connection for a PC	67
5.1.13.7. Communication parameters	68
5.1.13.8. Parallel communication support	69
5.1.13.9. System structure	70
5.1.13.10. LON inputs and outputs via a LON bus	72
5.1.14. Display panel (HMI)	74
5.1.15. Alarm LED indicators	75
5.1.15.1. Non-latched alarm	76
5.1.15.2. Latched alarm, steady LED	77
5.1.15.3. Latched alarm, blinking LEDs	77
5.1.15.4. Interlocking	78
5.2. Design description	79
5.2.1. Technical data	79
5.2.2. Terminal diagram of REM 543	84
5.2.3. Terminal diagram of REM 545	85
5.2.4. Terminal diagram of the RTD/analog module	86
5.2.5. Definition of power direction	86
5.2.6. Terminal connections	87
6. Service	90
7. Ordering Information	91
7.1. Order number	91
7.2. Hardware versions of REM 543 and REM 545	92
7.3. Software configuration	92
8. Revision History of REM 54_	93
8.1. Revision identification	93
8.2. Release Q4/08	93
8.2.1. Changes and additions to earlier released revisions ..	93
8.2.2. Configuration, setting and SA system tools	93
8.3. Patch release, SW build 4.00	94
8.3.1. Changes and additions to earlier released revisions ..	94

Issued: 16.10.1998
Version: N/25.10.2010

Technical Reference Manual, General

8.3.2. Configuration, setting and SA system tools	94
8.4. Release 2.5	94
8.4.1. Changes and additions to earlier released revisions ..	94
8.4.2. Configuration, setting and SA system tools	95
8.5. Release 2.0	95
8.5.1. Changes and additions to earlier released revisions ..	95
8.5.2. Configuration, setting and SA system tools	98
9. Abbreviations	99
10. Index	100
11.	

1. About this manual

1.1. Copyrights

The information in this document is subject to change without notice and should not be construed as a commitment by ABB Oy. ABB Oy assumes no responsibility for any errors that may appear in this document.

In no event shall ABB Oy be liable for direct, indirect, special, incidental or consequential damages of any nature or kind arising from the use of this document, nor shall ABB Oy be liable for incidental or consequential damages arising from use of any software or hardware described in this document.

This document and parts thereof must not be reproduced or copied without written permission from ABB Oy, and the contents thereof must not be imparted to a third party nor used for any unauthorized purpose.

The software or hardware described in this document is furnished under a license and may be used, copied, or disclosed only in accordance with the terms of such license.

Copyright © 2008 ABB Oy
All rights reserved.

1.2. Trademarks

ABB is a registered trademark of ABB Group. All other brand or product names mentioned in this document may be trademarks or registered trademarks of their respective holders.

1.3. Guarantee

Please inquire about the terms of guarantee from your nearest ABB representative.

1.4. This manual

This document provides a general description of the machine terminals REM 543 and REM 545, Release 2.5. For more information about the earlier revisions, refer to section “Revision History of REM 54_” on page 93.

For detailed information about the separate function blocks, refer to version 2.2 or later of the CD-ROM Technical Descriptions of Functions (see “Related documents” on page 8).

1.5. Use of symbols

This publication includes the following icons that point out safety-related conditions or other important information:



The electrical warning icon indicates the presence of a hazard which could result in electrical shock.



The caution icon indicates important information or warning related to the concept discussed in the text. It might indicate the presence of a hazard which could result in corruption of software or damage to equipment or property.



The information icon alerts the reader to relevant facts and conditions.

Although warning hazards are related to personal injury, it should be understood that operation of damaged equipment could, under certain operational conditions, result in degraded process performance leading to personal injury or death. Therefore, comply fully with all warning and caution notices.

1.6.

Related documents

Manuals for REM 54_

- Configuration Guideline 1MRS750745-MUM
- Operator's Manual 1MRS 751500-MUM
- Installation Manual 1MRS 750526-MUM
- REM 54_ Modbus Remote Communication Protocol, Technical Description 1MRS750781-MUM
- Technical Descriptions of Functions (CD-ROM) 1MRS750889-MCD
- REM 543 Modbus Configurations (CD-ROM) 1MRS151023

Parameter and event lists for REM 54_

- Parameter List for REM 543 and REM 545 1MRS751784-MTI
- Event List for REM 543 and REM 545 1MRS751785-MTI

Bus Connection Modules_

- RER 103 Bus Connection Module, Technical Description 1MRS750532-MUM
- RER 123 Bus Connection Module, Technical Description 1MRS751143-MUM
- RER 133 Bus Connection Module, Technical Description 1MRS755163
- SPA-ZC 302 Profibus-DPV1/SPA Gateway, Installation and Commissioning Manual 1MRS755014
- SPA-ZC 400 Ethernet Adapter, Installation and Commissioning Manual 1MRS755347

Technical Reference Manual, General

Tool-specific manuals

- CAP505 Installation and Commissioning Manual 1MRS751901-MEN
- CAP505 User's Guide 1MRS752292-MEN
- CAP505 Protocol Mapping Tool Operator's Manual 1MRS755277
- Tools for Relays and Terminals, User's Guide 1MRS752008-MUM
- CAP 501 Installation and Commissioning Manual 1MRS751899-MEN
- CAP 501 User's Guide 1MRS751900-MUM

1.7.

Document revisions

Version	Date	History
D	11.05.2000	Gas pressure monitoring (CMGAS1, CMGAS3) description updated
E	14.06.2002	Filtering times of digital inputs Technical data corrections New protection functions: SCVCSt_, DOC6_ Modbus communication protocol (RTU and ASCII implementation)
F	31.03.2006	New HMI faceplate Layout updated
G	29.09.2006	RER 133 added to manual
H	27.06.2008	Protocol & communication bus details added
K	19.12.2008	Manual updated
M	27.05.2010	Manual updated
N	25.10.2010	Manual updated

2. Safety information



Dangerous voltages can occur on the connectors, even though the auxiliary voltage has been disconnected.

Non-observance can result in death, personal injury or substantial property damage.

Only a competent electrician is allowed to carry out the electrical installation.

National and local electrical safety regulations must always be followed.

The frame of the device has to be carefully earthed.



The device contains components which are sensitive to electrostatic discharge. Unnecessary touching of electronic components must therefore be avoided.

Breaking the sealing tape on the rear panel of the device will result in loss of warranty and proper operation will no longer be guaranteed.

3. Introduction

3.1. General

The REM 54_ rotating machine terminal is part of the ABB Distribution Automation system and extends the functionality and flexibility of the concept further. This is possible due to the modern technology applied both in hardware and software solutions.

Increased performance is achieved by utilizing the multiprocessor architecture. Digital signal processing combined with a powerful CPU and distributed I/O handling facilitates parallel operations and improves response times and accuracy. The HMI¹, including an LCD display with different views, makes the local use of the REM 54_ rotating machine terminal safe and easy. The HMI instructs the user how to proceed.



A060245

Fig. 3.1.-1 REM 54_ rotating machine terminal

3.2. Hardware versions

The REM 54_ rotating machine terminal contains several hardware versions. Depending on the number of I/Os available, the product is called REM 543 or REM 545.

1. HMI is referred to as MMI in the relay and in the Relay Setting Tool

Table 3.2.-1 Hardware versions of REM 543

HW modules	Order number													
	REM543C_212AAAA	REM543C_212CAAA	REM543C_212AABA	REM543C_212CABA	REM543C_212AAAB	REM543C_212AABB	REM543C_212BAAA	REM543B_213AAAA	REM543B_213CAAA	REM543B_213AABA	REM543B_213CABA	REM543B_213AAAB	REM543B_213AABB	REM543B_213BAAA
Analog interface														
Sensor channels (current/ voltage)			9	9		9				9	9		9	
Current trafo 1/5 A	4	4	4	4	4	4	4	4	4	4	4	4	4	4
Current trafo 0.2/1 A	1	1	1	1	1	1	1	1	1	1	1	1	1	1
Voltage trafo 100 V	4	4	4	4	4	4	4	4	4	4	4	4	4	4
Main processor boards														
CPU module	1	1	1	1	1	1	1	1	1	1	1	1	1	1
Power supply boards														
PS1: 80...265 V AC/DC (High)							1							1
PS1: 80...265 V AC/DC (Medium)	1		1		1	1		1		1		1	1	
PS1: 18...80 V DC (Low)		1		1					1		1			
Digital I/O boards														
BIO1: threshold voltage 155 V DC							1							1
BIO1: threshold voltage 80 V DC	1		1		1	1		1		1		1	1	
BIO1: threshold voltage 18 V DC		1		1					1		1			
BIO2: threshold voltage 155 V DC														
BIO2: threshold voltage 80 V DC														
BIO2: threshold voltage 18 V DC														
Analog I/O board														
RTD/analog module								1	1	1	1	1	1	1
Display boards														
Graphic HMI display, fixed	1	1	1	1			1	1	1	1	1			1
Graphic HMI display, external					1	1						1	1	
Mechanic														
1/2 enclosure	1	1	1	1	1	1	1	1	1	1	1	1	1	1
Digital inputs	15							15						
Power outputs, single pole	0							0						
Power outputs, double pole	5							5						
Signal outputs (NO)	2							2						
Signal outputs (NO/NC)	5							5						
Supervised trip circuits	2							2						
IRF outputs	1							1						
RTD/analog inputs	0							8						
Analog outputs	0							4						

Table 3.2.-2 Hardware versions of REM 543 (Continued)

HW modules	Order number													
	REM543C_214AAAA	REM543C_214CAAA	REM543C_214AABA	REM543C_214CABA	REM543C_214AAAB	REM543C_214AABB	REM543C_214BAAA	REM543B_215AAAA	REM543B_215CAAA	REM543B_215AABA	REM543B_215CABA	REM543B_215AAAB	REM543B_215AABB	REM543B_215BAAA
Analog interface														
Sensor channels (current/ voltage)			9	9		9				9	9		9	
Current trafo 1/5 A	6	6	6	6	6	6	6	6	6	6	6	6	6	6
Current trafo 0.2/1 A														
Voltage trafo 100 V	3	3	3	3	3	3	3	3	3	3	3	3	3	3
Main processor boards														
CPU module	1	1	1	1	1	1	1	1	1	1	1	1	1	1
Power supply boards														
PS1: 80...265 V AC/DC (High)							1							1
PS1: 80...265 V AC/DC (Medium)	1		1		1	1		1		1		1	1	
PS1: 18...80V DC (Low)		1		1					1		1			
Digital I/O boards														
BIO1: threshold voltage 155 V DC							1							1
BIO1: threshold voltage 80 V DC	1		1		1	1		1		1		1	1	
BIO1: threshold voltage 18 V DC		1		1					1		1			
BIO2: threshold voltage 155 V DC														
BIO2: threshold voltage 80 V DC														
BIO2: threshold voltage 18 V DC														
Analog I/O board														
RTD/analog module								1	1	1	1	1	1	1
Display boards														
Graphic HMI display, fixed	1	1	1	1			1	1	1	1	1			1
Graphic HMI display, external					1	1						1	1	
Mechanic														
1/2 enclosure	1	1	1	1	1	1	1	1	1	1	1	1	1	1
Digital inputs														
	15							15						
Power outputs, single pole														
	0							0						
Power outputs, double pole														
	5							5						
Signal outputs (NO)														
	2							2						
Signal outputs (NO/NC)														
	5							5						
Supervised trip circuits														
	2							2						
IRF outputs														
	1							1						
RTD/analog inputs														
	0							8						
Analog outputs														
	0							4						

Table 3.2.-3 Hardware versions of REM 543 (Continued)

HW modules	Order number													
	REM543C_216AAAA	REM543C_216CAAA	REM543C_216AABA	REM543C_216CABA	REM543C_216AAAB	REM543C_216AABB	REM543C_216BAAA	REM543B_217AAAA	REM543B_217CAAA	REM543B_217AABA	REM543B_217CABA	REM543B_217AAAB	REM543B_217AABB	REM543B_217BAAA
Analog interface														
Sensor channels (current/ voltage)			9	9		9				9	9		9	
Current trafo 1/5 A	7	7	7	7	7	7	7	7	7	7	7	7	7	7
Current trafo 0.2/1 A														
Voltage trafo 100 V	2	2	2	2	2	2	2	2	2	2	2	2	2	2
Main processor boards														
CPU module	1	1	1	1	1	1	1	1	1	1	1	1	1	1
Power supply boards														
PS1: 80...265 V AC/DC (High)							1							1
PS1: 80...265 V AC/DC (Medium)	1		1		1	1		1		1		1	1	
PS1: 18...80 V DC (Low)		1		1					1		1			
Digital I/O boards														
BIO1: threshold voltage 155 V DC							1							1
BIO1: threshold voltage 80 V DC	1		1		1	1		1		1		1	1	
BIO1: threshold voltage 18 V DC		1		1					1		1			
BIO2: threshold voltage 155 V DC														
BIO2: threshold voltage 80 V DC														
BIO2: threshold voltage 18 V DC														
Analog I/O board														
RTD/analog module								1	1	1	1	1	1	1
Display boards														
Graphic HMI display, fixed	1	1	1	1			1	1	1	1	1			1
Graphic HMI display, external					1	1						1	1	
Mechanic														
1/2 enclosure	1	1	1	1	1	1	1	1	1	1	1	1	1	1
Digital inputs	15							15						
Power outputs, single pole	0							0						
Power outputs, double pole	5							5						
Signal outputs (NO)	2							2						
Signal outputs (NO/NC)	5							5						
Supervised trip circuits	2							2						
IRF outputs	1							1						
RTD/analog inputs	0							8						
Analog outputs	0							4						

Technical Reference Manual, General

Table 3.2.-4 Hardware versions of REM 543 (Continued)

HW modules	Order number											
	REM543C_218AAAA	REM543C_218CAAA	REM543C_218AABA	REM543C_218CABA	REM543C_218AAAB	REM543C_218AABB	REM543B_219AAAA	REM543B_219CAAA	REM543B_219AABA	REM543B_219CABA	REM543B_219AAAB	REM543B_219AABB
Analog interface												
Sensor channels (current/ voltage)			9	9		9			9	9		9
Current trafo 1/5 A	8	8	8	8	8	8	8	8	8	8	8	8
Current trafo 0.2/1 A												
Voltage trafo 100 V	1	1	1	1	1	1	1	1	1	1	1	1
Main processor boards												
CPU module	1	1	1	1	1	1	1	1	1	1	1	1
Power supply boards												
PS1: 110/120/220/240 V AC/ 110/125/220 V DC	1		1		1	1	1		1		1	1
PS1: 24/48/60 V DC		1		1				1		1		
Digital I/O boards												
BIO1: threshold voltage 80 V DC	1		1		1	1	1		1		1	1
BIO1: threshold voltage 18 V DC		1		1				1		1		
BIO2: threshold voltage 80 V DC												
BIO2: threshold voltage 18 V DC												
Analog I/O board												
RTD/analog module							1	1	1	1	1	1
Display boards												
Graphic HMI display, fixed	1	1	1	1			1	1	1	1		
Graphic HMI display, external					1	1					1	1
Mechanic												
1/2 enclosure	1	1	1	1	1	1	1	1	1	1	1	1
Digital inputs	15						15					
Power outputs, single pole	0						0					
Power outputs, double pole	5						5					
Signal outputs (NO)	2						2					
Signal outputs (NO/NC)	5						5					
Supervised trip circuits	2						2					
IRF outputs	1						1					
RTD/analog inputs	0						8					
Analog outputs	0						4					

Table 3.2.-5 Hardware versions of REM 545

HW modules	Order number													
	REM545B_222AAAA	REM545B_222CAAA	REM545B_222AABA	REM545B_222CABA	REM545B_222AAAB	REM545B_222AABB	REM545B_222BAAA	REM545B_223AAAA	REM545B_223CAAA	REM545B_223AABA	REM545B_223CABA	REM545B_223AAAB	REM545B_223AABB	REM545B_223BAAA
Analog interface														
Sensor channels (current/ voltage)			9	9		9				9	9		9	
Current trafo 1/5 A	4	4	4	4	4	4	4	4	4	4	4	4	4	4
Current trafo 0.2/1 A	1	1	1	1	1	1	1	1	1	1	1	1	1	1
Voltage trafo 100 V	4	4	4	4	4	4	4	4	4	4	4	4	4	4
Main processor boards														
CPU module	1	1	1	1	1	1	1	1	1	1	1	1	1	1
Power supply boards														
PS1: 80...265 V AC/DC (High)							1							1
PS1: 80...265 V AC/DC (Medium)	1		1		1	1		1		1		1	1	
PS1: 18...80 V DC (Low)		1		1					1		1			
Digital I/O boards														
BIO1: threshold voltage 155 V DC							1							1
BIO1: threshold voltage 80 V DC	1		1		1	1		1		1		1	1	
BIO1: threshold voltage 18 V DC		1		1					1		1			
BIO2: threshold voltage 155 V DC							1							1
BIO2: threshold voltage 80 V DC	1		1		1	1		1		1		1	1	
BIO2: threshold voltage 18 V DC		1		1					1		1			
Analog I/O board														
RTD/analog module								1	1	1	1	1	1	1
Display boards														
Graphic HMI display, fixed	1	1	1	1			1	1	1	1	1			1
Graphic HMI display, external					1	1						1	1	
Mechanic														
1/2 enclosure	1	1	1	1	1	1	1	1	1	1	1	1	1	1
Digital inputs	25							25						
Power outputs, single pole	2							2						
Power outputs, double pole	9							9						
Signal outputs (NO)	2							2						
Signal outputs (NO/NC)	5							5						
Supervised trip circuits	2							2						
IRF outputs	1							1						
RTD/analog inputs	0							8						
Analog outputs	0							4						

Table 3.2.-6 Hardware versions of REM 545 (Continued)

HW modules	Order number													
	REM545B_224AAAA	REM545B_224CAAA	REM545B_224AABA	REM545B_224CABA	REM545B_224AAAB	REM545B_224AABB	REM545B_224BAAA	REM545B_225AAAA	REM545B_225CAAA	REM545B_225AABA	REM545B_225CABA	REM545B_225AAAB	REM545B_225AABB	REM545B_225BAAA
Analog interface														
Sensor channels (current/ voltage)			9	9		9				9	9		9	
Current trafo 1/5 A	6	6	6	6	6	6	6	6	6	6	6	6	6	6
Current trafo 0.2/1 A														
Voltage trafo 100 V	3	3	3	3	3	3	3	3	3	3	3	3	3	3
Main processor boards														
CPU module	1	1	1	1	1	1	1	1	1	1	1	1	1	1
Power supply boards														
PS1: 80...265 V AC/DC (High)							1							1
PS1: 80...265 V AC/DC (Medium)	1		1		1	1		1		1		1	1	
PS1: 18...80 V DC (Low)		1		1					1		1			
Digital I/O boards														
BIO1: threshold voltage 155 V DC							1							1
BIO1: threshold voltage 80 V DC	1		1		1	1		1		1		1	1	
BIO1: threshold voltage 18 V DC		1		1					1		1			
BIO2: threshold voltage 155 V DC							1							1
BIO2: threshold voltage 80 V DC	1		1		1	1		1		1		1	1	
BIO2: threshold voltage 18 V DC		1		1					1		1			
Analog I/O board														
RTD/analog module								1	1	1	1	1	1	1
Display boards														
Graphic HMI display, fixed	1	1	1	1			1	1	1	1	1			1
Graphic HMI display, external					1	1						1	1	
Mechanic														
1/2 enclosure	1	1	1	1	1	1	1	1	1	1	1	1	1	1
Digital inputs														
	25							25						
Power outputs, single pole														
	2							2						
Power outputs, double pole														
	9							9						
Signal outputs (NO)														
	2							2						
Signal outputs (NO/NC)														
	5							5						
Supervised trip circuits														
	2							2						
IRF outputs														
	1							1						
RTD/analog inputs														
	0							8						
Analog outputs														
	0							4						

Table 3.2.-7 Hardware versions of REM 545 (Continued)

HW modules	Order number													
	REM545B_226AAAA	REM545B_226CAAA	REM545B_226AABA	REM545B_226CABA	REM545B_226AAAB	REM545B_226AABB	REM545B_226BAAA	REM545B_227AAAA	REM545B_227CAAA	REM545B_227AABA	REM545B_227CABA	REM545B_227AAAB	REM545B_227AABB	REM545B_227BAAA
Analog interface														
Sensor channels (current/ voltage)			9	9		9				9	9		9	
Current trafo 1/5 A	7	7	7	7	7	7	7	7	7	7	7	7	7	7
Current trafo 0.2/1 A														
Voltage trafo 100 V	2	2	2	2	2	2	2	2	2	2	2	2	2	2
Main processor boards														
CPU module	1	1	1	1	1	1	1	1	1	1	1	1	1	1
Power supply boards														
PS1: 80...265 V AC/DC (High)							1							1
PS1: 80...265 V AC/DC (Medium)	1		1		1	1		1		1		1	1	
PS1: 18...80 V DC (Low)		1		1					1		1			
Digital I/O boards														
BIO1: threshold voltage 155 V DC							1							1
BIO1: threshold voltage 80 V DC	1		1		1	1		1		1		1	1	
BIO1: threshold voltage 18 V DC		1		1					1		1			
BIO2: threshold voltage 155 V DC							1							1
BIO2: threshold voltage 80 V DC	1		1		1	1		1		1		1	1	
BIO2: threshold voltage 18 V DC		1		1					1		1			
Analog I/O board														
RTD/analog module								1	1	1	1	1	1	1
Display boards														
Graphic HMI display, fixed	1	1	1	1			1	1	1	1	1			1
Graphic HMI display, external					1	1						1	1	
Mechanic														
1/2 enclosure	1	1	1	1	1	1	1	1	1	1	1	1	1	1
Digital inputs	25							25						
Power outputs, single pole	2							2						
Power outputs, double pole	9							9						
Signal outputs (NO)	2							2						
Signal outputs (NO/NC)	5							5						
Supervised trip circuits	2							2						
IRF outputs	1							1						
RTD/analog inputs	0							8						
Analog outputs	0							4						

Table 3.2.-8 Hardware versions of REM 545 (Continued)

HW modules	Order number											
	REM545B_228AAAA	REM545B_228CAAA	REM545B_228AABA	REM545B_228CABA	REM545B_228AAAB	REM545B_228AABB	REM545B_229AAAA	REM545B_229CAAA	REM545B_229AABA	REM545B_229CABA	REM545B_229AAAB	REM545B_229AABB
Analog interface												
Sensor channels (current/ voltage)			9	9		9			9	9		9
Current trafo 1/5 A	8	8	8	8	8	8	8	8	8	8	8	8
Current trafo 0.2/1 A												
Voltage trafo 100 V	1	1	1	1	1	1	1	1	1	1	1	1
Main processor boards												
CPU module	1	1	1	1	1	1	1	1	1	1	1	1
Power supply boards												
PS1: 110/120/220/240 V AC/ 110/125/220 V DC	1		1		1	1	1		1		1	1
PS1: 24/48/60 V DC		1		1				1		1		
Digital I/O boards												
BIO1: threshold voltage 80 V DC	1		1		1	1	1		1		1	1
BIO1: threshold voltage 18 V DC		1		1				1		1		
BIO2: threshold voltage 80 V DC	1		1		1	1	1		1		1	1
BIO2: threshold voltage 18 V DC		1		1				1		1		
Analog I/O board												
RTD/analog module							1	1	1	1	1	1
Display boards												
Graphic HMI display, fixed	1	1	1	1			1	1	1	1		
Graphic HMI display, external					1	1					1	1
Mechanic												
1/2 enclosure	1	1	1	1	1	1	1	1	1	1	1	1
Digital inputs	25						25					
Power outputs, single pole	2						2					
Power outputs, double pole	9						9					
Signal outputs (NO)	2						2					
Signal outputs (NO/NC)	5						5					
Supervised trip circuits	2						2					
IRF outputs	1						1					
RTD/analog inputs	0						8					
Analog outputs	0						4					

4. Instructions

4.1. Application

The REM 54_ rotating machine terminals (referred to as “machine terminals” further on) are designed to be used as the main protection system of generator and generator-transformer units in small and medium-power diesel, hydroelectric and steam power plants, etc. The protection of large and/or important MV synchronous and asynchronous motors used e.g. in pumps, mills and crushers during start-up and normal run forms another application area.

The functionality available for the machine terminals depends on the selected functionality level (refer to section “Ordering Information” on page 91) and is also tied to the hardware configuration. The desired functions can be activated from a wide range of protection, control, measurement, condition monitoring, general and communication functions within the scope of I/O connections, considering the total CPU load. Compared to the traditional use of separate products, the combination of desired functions provides cost-effective solutions and, together with the relay configuration (IEC 61131-3 standard), allows the machine terminals to be easily adapted to different kinds of applications.

By means of the graphic HMI display, the control functions in the machine terminal indicate the status of disconnectors or circuit breakers locally. Further, the machine terminal allows status information from the circuit breakers and the disconnectors to be transmitted to the remote control system. Controllable objects, such as CBs, can be opened and closed over the remote control system. Status information and control signals are transmitted over the serial bus. Local control is also possible via the push-buttons on the front panel of the machine terminal.

The protection functions of the machine terminals are designed for selective short-circuit and earth-fault protection of rotating machines. Further, unlike most other power system components, rotating machines also need protection against abnormal operating conditions such as overcurrent, unbalanced load, overtemperature, over- and undervoltage, over- and underexcitation, over- and underfrequency and generator motoring. Also, underimpedance function is provided for line back-up. Furthermore, stall protection and cumulative start-up counter are provided for motor protection start-up supervision.

The machine terminals measure phase currents, phase-to-phase or phase-to-earth voltages, neutral current, residual voltage, frequency and power factors. Active and reactive power is calculated from measured currents and voltages. Energy can be calculated on the basis of the measured power. The measured values can be indicated locally and remotely as scaled primary values.

In addition to protection, measurement, control, condition monitoring and general functions, the machine terminals are provided with a large amount of PLC functions allowing several automation and sequence logic functions needed for substation automation to be integrated into one unit. The data communication properties include SPA bus, Modbus or LON bus communication with higher-level equipment. Further, LON communication, together with PLC functions, minimizes the need for hardwiring between the machine terminals.

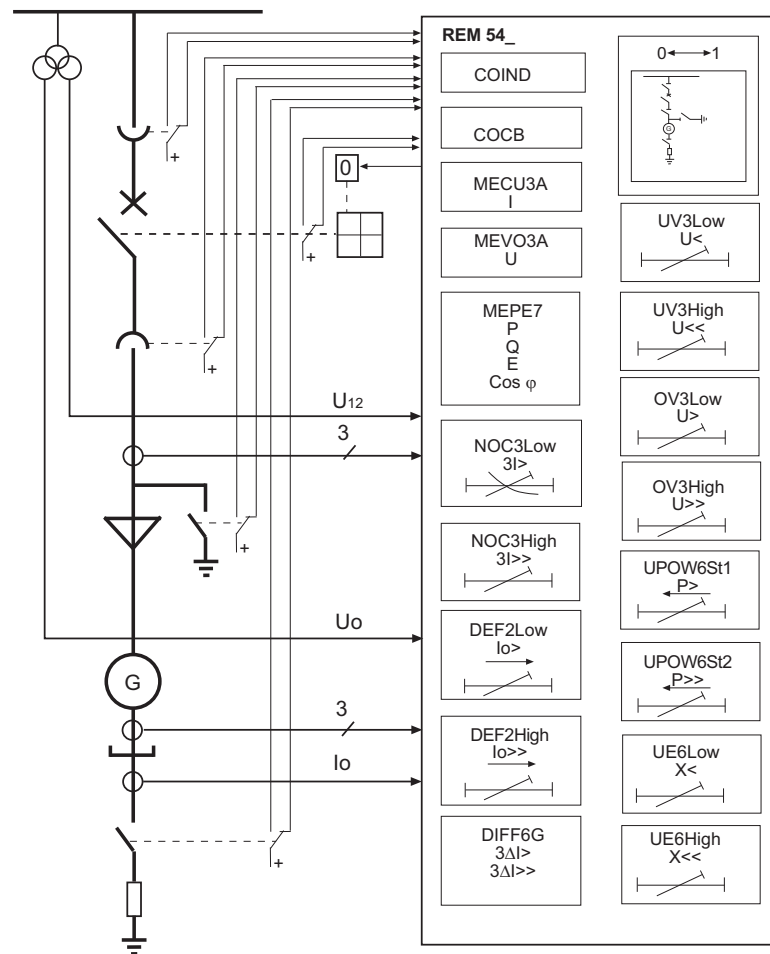

A060246

Fig. 4.1.-1 Basic functions of the integrated machine terminal REM 54_

4.2.

Requirements

If the environmental conditions differ from those specified in section “Technical data” on page 79, as to temperature and humidity, or if the atmosphere around the machine terminal contains chemically active gases or dust, the terminal should be visually inspected in association with the secondary testing. The visual inspection should focus on:

- Signs of mechanical damage to the terminal case and terminals
- Dust inside the terminal cover or case; remove carefully with compressed air
- Signs of corrosion on the cable terminals, on or inside the terminal case

For information about the maintenance of machine terminals, refer to Chapter 6. Service.



Machine terminals are measuring instruments and should be handled with care and protected against moisture and mechanical stress, especially during transport.

4.3. Configuration

The REM 54_ machine terminals are adapted to specific applications by using the Relay Configuration Tool included in the CAP 505 tools. This tool is used for configuring the basic terminal, protection and logic function blocks, control and measurement functions, timers and other functional elements included in the logic functions category (refer to section “Machine terminal configuration” on page 30).

The MIMIC picture, alarm texts and LED indicators are configured with the Relay Mimic Editor (refer to section “MIMIC configuration” on page 31).

The configuration of LON network is described in section “LON network configuration” on page 32. If the application includes no horizontal communication, network variables are not needed and the section about LON network configuration is thus not relevant.

The configuration of Modbus network is described in section “Modbus configuration” on page 33.

The configuration procedure starts by configuring the functions of protection, control, condition monitoring, measurement and logics.

For more detailed information about the configuration, refer to the Configuration Guideline and the tool-specific manuals (see “Related documents” on page 8).

For more information about the Modbus configurations, refer to the CD-ROM REM 543 Modbus Configurations (see “Related documents” on page 8).

5. Technical Description

5.1. Functional description

5.1.1. Functions of the machine terminal

The functions of REM 54_ machine terminal are categorized as:

- protection functions
- measurement functions
- control functions
- condition monitoring functions
- communication functions
- general functions
- standard functions

The functions are further divided to two subsets that correspond to different functionality levels (refer to section “Ordering Information” on page 91).

5.1.1.1. Protection functions

Protection is one of the most important functions of the machine terminal. The protection function blocks (e.g. NOC3Low) are independent of each other and have their own setting groups, data recording, etc. The non-directional overcurrent protection, for example, includes the three stages NOC3Low, NOC3High and NOC3Inst, each with independent protection functions.

Either Rogowski coils or conventional current transformers can be used for protection functions based on current measurement (overcurrent). Correspondingly, voltage dividers or voltage transformers are used for protection functions based on voltage measurement (overvoltage).

The protection function blocks are documented on the CD-ROM Technical Descriptions of Functions.

Table 5.1.1.1-1 Protection functions available for REM 54_

Function	Description
DEF2Low	Directional earth-fault protection, low-set stage
DEF2High	Directional earth-fault protection, high-set stage
DEF2Inst	Directional earth-fault protection, instantaneous stage
Diff3 ^a	High-impedance or flux-balance based differential protection for generators and motors
Diff6G	Stabilized three-phase differential protection for generators
DOC6Low ^b	Three-phase directional O/C function, low-set stage > ->
DOC6High ^b	Three-phase directional O/C function, high-set stage >> ->
DOC6Inst ^b	Three-phase directional O/C function, instantaneous stage >>> ->
Freq1St1	Underfrequency or overfrequency protection, stage 1
Freq1St2	Underfrequency or overfrequency protection, stage 2
Freq1St3	Underfrequency or overfrequency protection, stage 3
Freq1St4	Underfrequency or overfrequency protection, stage 4

Table 5.1.1.1-1 Protection functions available for REM 54_ (Continued)

Function	Description
Freq1St5	Underfrequency or overfrequency protection, stage 5
FuseFail ^a	Fuse failure supervision
Inrush3	Three-phase transformer inrush and motor start-up current detector
MotStart	Three-phase start-up supervision for motors
NEF1Low	Non-directional earth-fault protection, low-set stage
NEF1High	Non-directional earth-fault protection, high-set stage
NEF1Inst	Non-directional earth-fault protection, instantaneous stage
NOC3Low	Three-phase non-directional overcurrent protection, low-set stage
NOC3High	Three-phase non-directional overcurrent protection, high-set stage
NOC3Inst	Three-phase non-directional overcurrent protection, instantaneous stage
NPS3Low	Negative-phase-sequence (NPS) protection, low-set stage
NPS3High	Negative-phase-sequence (NPS) protection, high-set stage
NUC3St1	Three-phase non-directional undercurrent protection, stage 1
NUC3St2	Three-phase non-directional undercurrent protection, stage 2
OE1Low ^a	Overexcitation protection, low-set stage
OE1High ^a	Overexcitation protection, high-set stage
OPOW6St1	Three-phase overpower protection, stage 1
OPOW6St2	Three-phase overpower protection, stage 2
OPOW6St3	Three-phase overpower protection, stage 3
OV3Low	Three-phase overvoltage protection, low-set stage
OV3High	Three-phase overvoltage protection, high-set stage
PREV3 ^a	Phase reversal protection
PSV3St1 ^a	Phase-sequence voltage protection, stage 1
PSV3St2 ^a	Phase-sequence voltage protection, stage 2
REF1A	High-impedance based restricted earth-fault protection
ROV1Low	Residual overvoltage protection, low-set stage
ROV1High	Residual overvoltage protection, high-set stage
ROV1Inst	Residual overvoltage protection, instantaneous stage
SCVCS1 ^b	Synchro-check/voltage check function, stage 1
SCVCS2 ^b	Synchro-check/voltage check function, stage 2
TOL3Dev	Three-phase thermal overload protection for devices
UE6Low	Three-phase underexcitation protection, low-set stage
UE6High	Three-phase underexcitation protection, high-set stage
UI6Low ^a	Three-phase underimpedance protection, low-set stage
UI6High ^a	Three-phase underimpedance protection, high-set stage
UPOW6St1	Three-phase underpower or reverse-power protection, stage 1
UPOW6St2	Three-phase underpower or reverse-power protection, stage 2
UPOW6St3	Three-phase underpower or reverse-power protection, stage 3
UV3Low	Three-phase undervoltage protection, low-set stage
UV3High	Three-phase undervoltage protection, high-set stage
VOC6Low	Voltage-dependent overcurrent protection, low-set stage
VOC6High	Voltage-dependent overcurrent protection, high-set stage

a. These functions are only supported in Release 2.0 or later, refer to section "Revision identification" on page 93.

b. These functions are only supported in Release 2.5 or later, refer to section "Revision identification" on page 93.

5.1.1.2.**Measurement functions**

The measurement function blocks are documented on the CD-ROM Technical Descriptions of Functions.

Table 5.1.1.2-1 Measurement functions available for REM 54_

Function	Description
MEAI1 ^a	General measurement 1 / analog input on RTD1 card
MEAI2 ^a	General measurement 2 / analog input on RTD1 card
MEAI3 ^a	General measurement 3 / analog input on RTD1 card
MEAI4 ^a	General measurement 4 / analog input on RTD1 card
MEAI5 ^a	General measurement 5 / analog input on RTD1 card
MEAI6 ^a	General measurement 6 / analog input on RTD1 card
MEAI7 ^a	General measurement 7 / analog input on RTD1 card
MEAI8 ^a	General measurement 8 / analog input on RTD1 card
MEAO1 ^a	Analog output 1 on RTD1 card
MEAO2 ^a	Analog output 2 on RTD1 card
MEAO3 ^a	Analog output 3 on RTD1 card
MEAO4 ^a	Analog output 4 on RTD1 card
MECU1A	Neutral current measurement, stage A
MECU1B	Neutral current measurement, stage B
MECU3A	Three-phase current measurement, stage A
MEDREC16	Transient disturbance recorder
MEFR1	System frequency measurement
MEPE7	Three-phase power and energy measurement
MEVO1A	Residual voltage measurement, stage A
MEVO3A	Three-phase voltage measurement, stage A

a. These functions are only supported in Release 2.0 or later, refer to section “Revision identification” on page 93.

5.1.1.3.**Control functions**

The control functions are used to indicate the status of switching devices, i.e. circuit breakers and disconnectors, and to execute open and close commands for controllable switching devices of the switchgear. Furthermore, there are supplementary functions for control logic purposes, e.g. on/off switches, MIMIC alarm LED control, numerical data for MIMIC and logic controlled control position selector.

The control functions configured with the Relay Configuration Tool can be associated with object status indicators that are part of the MIMIC configuration picture displayed on the HMI. The object status indicators are used to indicate the status of switching devices via the MIMIC picture and to control them locally. For more information about the MIMIC configuration, refer to section “MIMIC configuration” on page 31.

Technical Reference Manual, General

The control function blocks are documented on the CD-ROM Technical Descriptions of Functions.

Table 5.1.1.3-1 Control functions available for REM 54_

Function	Description
COCB1	Circuit breaker 1 control with indication
COCB2	Circuit breaker 2 control with indication
COCBDIR	Direct open for CBs via HMI
CO3DC1	Three-state disconnecter (1) with indication
CO3DC2	Three-state disconnecter (2) with indication
CODC1	Disconnecter 1 control with indication
CODC2	Disconnecter 2 control with indication
CODC3	Disconnecter 3 control with indication
CODC4	Disconnecter 4 control with indication
CODC5	Disconnecter 5 control with indication
COIND1	Switching device 1 indication
COIND2	Switching device 2 indication
COIND3	Switching device 3 indication
COIND4	Switching device 4 indication
COIND5	Switching device 5 indication
COIND6	Switching device 6 indication
COIND7	Switching device 7 indication
COIND8	Switching device 8 indication
COLOCAT	Logic-controlled control position selector
COSW1	On/off switch 1
COSW2	On/off switch 2
COSW3	On/off switch 3
COSW4	On/off switch 4
MMIALAR1	Alarm channel 1, LED indication
MMIALAR2	Alarm channel 2, LED indication
MMIALAR3	Alarm channel 3, LED indication
MMIALAR4	Alarm channel 4, LED indication
MMIALAR5	Alarm channel 5, LED indication
MMIALAR6	Alarm channel 6, LED indication
MMIALAR7	Alarm channel 7, LED indication
MMIALAR8	Alarm channel 8, LED indication
MMIDATA1	MIMIC data monitoring point 1
MMIDATA2	MIMIC data monitoring point 2
MMIDATA3	MIMIC data monitoring point 3
MMIDATA4	MIMIC data monitoring point 4
MMIDATA5	MIMIC data monitoring point 5

5.1.1.4. Condition monitoring functions

The condition monitoring function blocks are documented on the CD-ROM Technical descriptions of Functions.

Table 5.1.1.4-1 Condition monitoring functions available for REM 54_

Function	Description
CMBWEAR1	Circuit-breaker electric wear 1
CMBWEAR2	Circuit-breaker electric wear 2
CMCU3	Supervision function of the energizing current input circuit
CMGAS1	Gas pressure monitoring 1
CMGAS3 ^a	Three-pole gas pressure monitoring
CMSCHED	Scheduled maintenance
CMSPRC1	Spring charging control 1
CMTCS1	Trip circuit supervision 1
CMTCS2	Trip circuit supervision 2
CMTIME1	Operate time counter 1 for the operate time used (e.g. motors)
CMTIME2	Operate time counter 2 for the operate time used (e.g. motors)
CMTRAV1	Breaker travel time 1
CMVO3	Supervision function of the energizing voltage input circuit

a. This function is only supported in Release 2.0 or later, refer to section “Revision identification” on page 93.

5.1.1.5. Communication functions

In a customer-specific machine terminal configuration, special events can be generated via an EVENT230 event function. EVENT230 is documented on the CD-ROM Technical descriptions of Functions.

For more information about communication in the REM 54_ machine terminal, refer to section “Serial communication” on page 66.

5.1.1.6. General functions

The general function blocks are documented on the CD-ROM Technical Descriptions of Functions.

Table 5.1.1.6-1 General functions available for REM 54_

Function	Description
INDRESET	Resetting of operation indicators, latched output signals, registers and waveforms i.e. the disturbance recorder
MMIWAKE	Activation of HMI backlight
SWGRP1	Switchgroup SWGRP1
SWGRP2	Switchgroup SWGRP2
SWGRP3	Switchgroup SWGRP3
.....	
SWGRP20	Switchgroup SWGRP20

5.1.1.7. Standard functions

Standard functions are used for logics such as interlocking, alarming and control sequencing. The use of logic functions is not limited and the functions can be interconnected with protection, control, measurement, condition monitoring and other standard functions. In addition, the digital inputs and outputs as well as LON inputs and outputs can be connected to standard functions by using the Relay Configuration Tool.

The standard function blocks are documented on the CD-ROM Technical descriptions of Functions.

Table 5.1.1.7-1 Standard functions available for REM 54_

Function	Description
ABS	Absolute value
ACOS	Principal arc cosine
ADD	Extensible adder
AND	Extensible AND connection
ASIN	Principal arc sine
ATAN	Principal arc tangent
BITGET	Get one bit
BITSET	Set one bit
BOOL_TO_*	Type conversion from BOOL to WORD / USINT / UINT / UDINT / SINT / REAL / INT / DWORD / DINT / BYTE
BOOL2INT	Type conversion from BOOL inputs to INT output
BYTE_TO_*	Type conversion from BYTE to WORD / DWORD
COMH	Hysteresis comparator
COS	Cosine in radians
CTD	Down-counter
CTUD	Up-down counter
CTU	Up-counter
DATE_TO_UDINT	Type conversion from DATE to UDINT
DINT_TO_*	Type conversion from DINT to SINT / REAL / INT
DIV	Divider
DWORD_TO_*	Type conversion from DWORD to WORD / BYTE
EQ	Extensible comparison to equal
EXP	Natural exponential
EXPT	Exponentiation
F_TRIG	Falling edge detector
GE	Extensible comparison to greater or equal
GT	Extensible comparison to greater
INT_TO_*	Type conversion from INT to REAL / DINT
INT2BOOL	Type conversion from INT input to BOOL outputs
LE	Extensible comparison to less or equal
LIMIT	Limitation
LN	Natural logarithm
LOG	Logarithm base 10
LT	Extensible comparison to less
MAX	Extensible maximum
MIN	Extensible minimum

Technical Reference Manual, General

Table 5.1.1.7-1 Standard functions available for REM 54_ (Continued)

Function	Description
MOD	Modulo
MOVE	Move
MUL	Extensible multiplier
MUX	Extensible multiplexer
NE	Comparison to greater or less
NOT	Complement
OR	Extensible OR connection
R_TRIG	Rising edge detector
REAL_TO_*	Type conversion from REAL to USINT / UINT / UDINT / SINT / INT / DINT
ROL	Rotate to left
ROR	Rotate to right
RS	Reset dominant bistable function block
RS_D	Reset dominant bistable function block with data input
SEL	Binary selection
SHL	Bit-shift to left
SHR	Bit-shift to right
SIN	Sine in radians
SINT_TO_*	Type conversion from SINT to REAL / INT / DINT
SUB	Subtractor
SQRT	Square root
SR	Set dominant bistable function block
XOR	Extensible exclusive OR connection
TAN	Tangent in radians
TIME_TO_*	Type conversion from TIME to UDINT / TOD / REAL
TOD_TO_*	Type conversion from TOD to UDINT / TIME / REAL
TOF	Off-delay timer
TON	On-delay timer
TP	Pulse
TRUNC_*	Truncation toward zero
UDINT_TO_*	Type conversion from UDINT to USINT / UINT / REAL
UINT_TO_*	Type conversion from UINT to USINT / UDINT / REAL / BOOL
USINT_TO_*	Type conversion from USINT to UINT / UDINT / REAL
WORD_TO_*	Type conversion from WORD to DWORD / BYTE

5.1.2. Configuration

5.1.2.1. Machine terminal configuration

The Relay Configuration Tool is based on the IEC 61131-3 standard. The standard defines the programming language used for configuration. The programmable system of the REM 54_ machine terminals allows the output contacts to be operated in accordance with the state of the logic inputs and the outputs of the protection, control, measurement and condition monitoring functions. The PLC functions (e.g. interlocking and alarm logic) are programmed with Boolean functions, timers, counters, comparators and flip-flops. The program is written in a function block diagram language by using the configuration software.

After the configuration has been built and successfully compiled, and the MIMIC configuration has been designed, the Relay Configuration Tool project (RCT project in CAP 505) including the relay configuration and MIMIC configuration can be downloaded to the relay with the Relay Download Tool. The project can also be uploaded from the machine terminal with the same tool¹. However, the relay configuration, the RCT project and the MIMIC configuration are saved in a non-volatile memory only after they have been stored via the parameter *Store*. To activate new configurations, the machine terminal should be reset via the parameter *Software reset*. These parameters can be found in the menu *Configuration/General*. Likewise, the storing and the resetting can be done by using the relay command buttons **Store** and **Reset** in the Relay Download Tool.

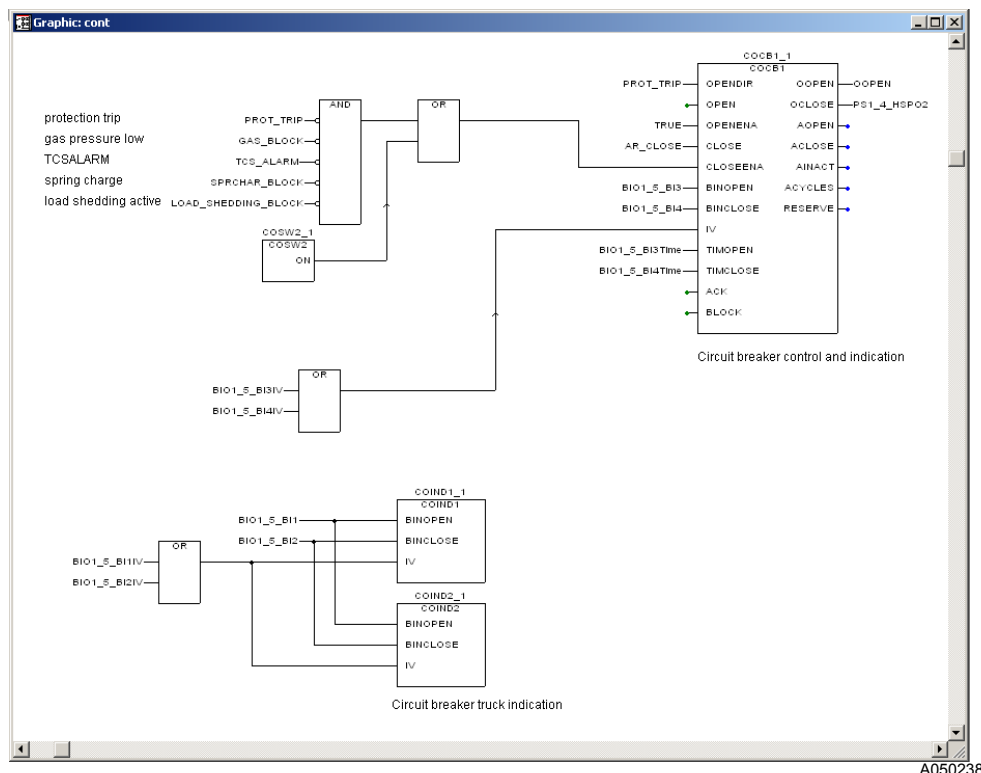

Fig. 5.1.2.1.-1 Example of a terminal configuration with the RCT

1. This function is only supported in Release 2.0 or later.

For more information about the configuration and the Relay Configuration Tool refer to the Configuration Guideline and the tool manuals (see “Related documents” on page 8).

5.1.2.2.

MIMIC configuration

The control functions configured with the Relay Configuration Tool must be associated with object status indicators that are part of the MIMIC configuration picture displayed on the graphic LCD of the HMI. The MIMIC configuration picture is designed with the Relay Mimic Editor. In addition, the editor is used to define the eight programmable LED indicators and the corresponding alarm texts on the front panel, the alarm modes, and the interlocking LED texts.

The MIMIC picture may include a single-line diagram, measured values with units, free texts, etc. The object status indicators (open, closed, undefined) are drawn according to the customer's requirements. Note that the operation of the objects themselves is determined by means of the Relay Configuration Tool.

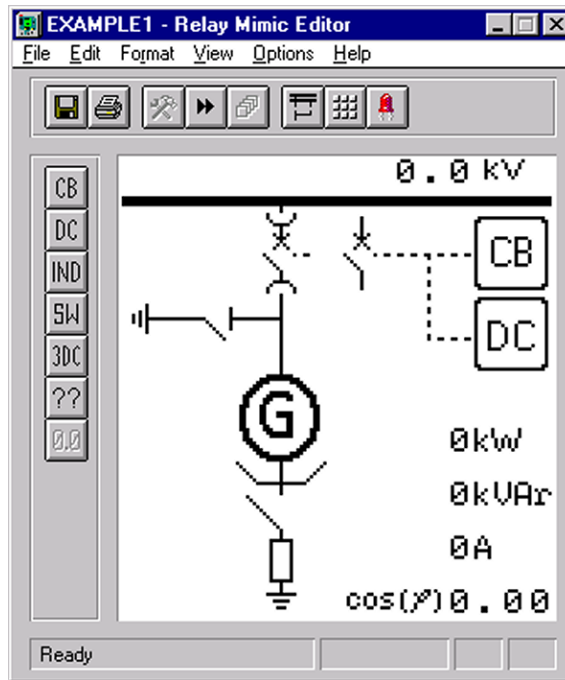

A060248

Fig. 5.1.2.2.-1 MIMIC configuration with the Relay Mimic Editor

The contents of the alarm view are configured with the Relay Mimic Editor by defining the ON and OFF state texts (max 16 characters), refer to section “MIMIC configuration” on page 31. For defining the corresponding LED colours refer to section “Alarm LED indicators” on page 75.

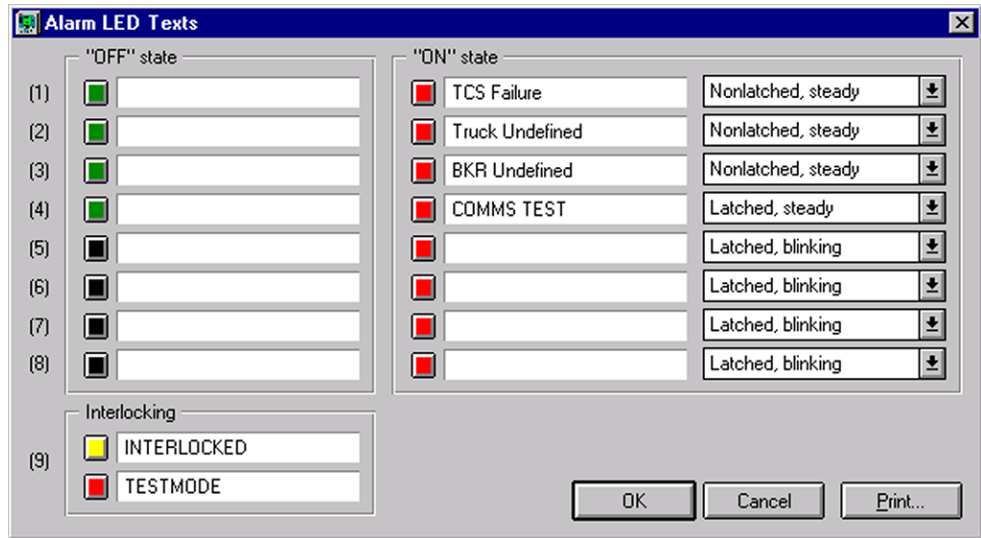

A060249

Fig. 5.1.2.2.-2 Alarm channel configuration

Interlocking LED texts can also be defined in the view illustrated above, but the interlocking LED colours cannot be changed. For the operation of the interlocking LED, refer to section “Interlocking” on page 78.

For more information about the use of the editor, refer to the Relay Mimic Editor manual (see “Related documents” on page 8).

5.1.2.3.

LON network configuration

The LON Network Tool is used for binding network variables between RED 500 terminals. Typically, LON is used for transferring status data between the terminals for interlocking sequences running in the units, refer to chapter 5.1.2.3.-1 below and Figure 5.1.13.10.-1 on page 73.

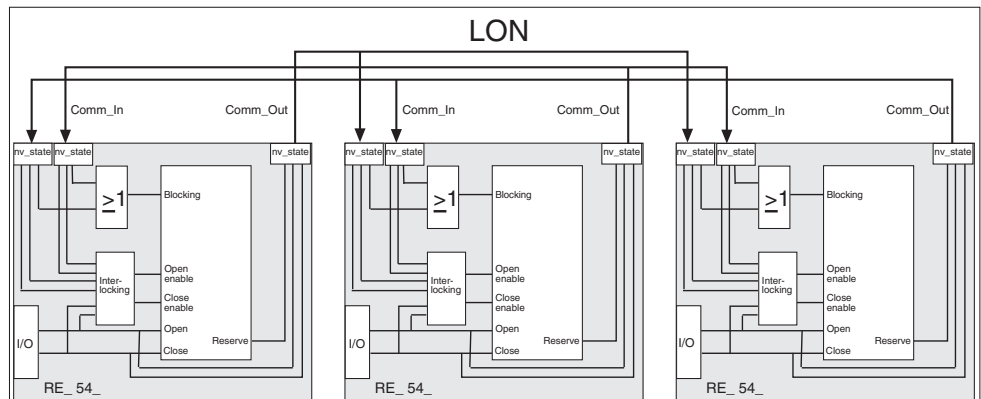

A050183

Fig. 5.1.2.3.-1 Communication between RED 500 terminals in station interlocking

For more information about the use of the tool, refer to the LNT 505 Operator’s Manual (see “Related documents” on page 8).

5.1.2.4. **Modbus configuration**

To configure REM 54_ for Modbus, communication parameters need to be set. These parameters can be found in the local menu of the machine terminal.

The Protocol Object Dictionary (POD) is a cross-reference table between the machine terminal application and the Modbus protocol. The table defines what information can be accessed from the device by using the protocol interface. The POD contents can be downloaded to the machine terminal by using the Relay Download Tool available in the CAP 505 tools. The new values of the communication parameters take effect only after they have been stored and the device has been reset. Modbus configurations for REM 543 including Modbus POD cross-reference tables and their explanations are available on a separate CD-ROM, REM 543 Modbus Configurations (see “Related documents” on page 8).

For more information about the configuration of the Modbus interface, refer to the Modbus Remote Communication Protocol for REM 54_, Technical Description manual (see “Related documents” on page 8).

5.1.2.5. **Rated frequency**

The rated frequency of the machine terminal is set in association with configuration via a dialog box in the Relay Configuration Tool. The set rated frequency cannot be changed afterwards via the HMI or serial communication, but it can be read via the global control parameter `Rated frequency` in the machine terminal.

5.1.3. **Parameters and events**

The function blocks and I/O cards include a large number of parameters and events. In addition, general parameters and events are provided, e.g. parameters for control and communication as well as events for testing and self-supervision.

The function block specific parameters are listed in each function block description. Moreover, all parameters and events for REM 54_ are listed in the parameter and event lists. The function block descriptions as well as the parameter and event lists are included on the CD-ROM Technical Descriptions of Functions (see “Related documents” on page 8).

5.1.4. **Parameterization**

To ensure that a protection function block protects the machine in the desired manner, the default values of parameters are to be checked and properly set before taking the function block into use.

The parameters can be set either locally over the HMI or externally via the serial communication. Note that the Modbus parameters can only be set locally.

5.1.4.1. **Local parameterization**

When the parameters are set locally via the HMI, the setting parameters can be chosen from the hierarchical menu structure. The desired language for parameter description can also be selected. Detailed information about setting and navigation is found in the RE_ 54_ Operator’s Manual.

5.1.4.2. External parameterization

The Relay Setting Tool is used for parameterizing and setting the machine terminals externally. The parameters can be set off-line on a PC and downloaded to the machine terminal over a communication port. The menu structure of the setting tool, including views relating to parameterization and settings, is the same as the menu structure of the machine terminal. The use of the tool is instructed in the RED Relay Tool Operator's Manual (see "Related documents" on page 8).

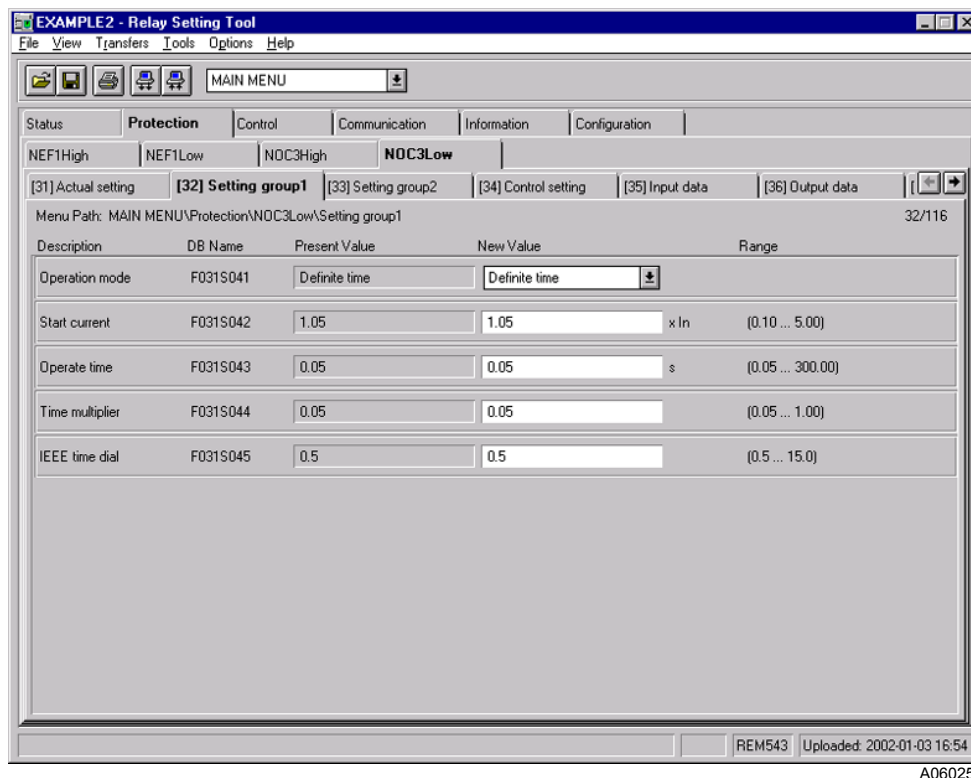

Fig. 5.1.4.2.-1 Main dialog window of the Relay Setting Tool

5.1.4.3. Storing of parameters and recorded data

When parameter values are changed, the new values take effect immediately. However, the new parameter values as well as the recorded data are saved in a non-volatile memory only after they have been stored via the parameter Store in the menu Configuration/General (refer to the Operator's Manual) or via the relay tools.

Provided the storing was completed successfully, the information stored in the non-volatile memory is preserved in the memory also in case of a power interruption. During the storing procedure, it is not possible to reset the machine terminal via the parameter Software reset or to load a new project.



When the values for the measuring devices (refer to section “Technical data of the measuring devices” on page 41) or communication parameters (refer to section “Serial communication” on page 66) are changed via the HMI or the Relay Setting Tool, the new values take effect only after they have been stored via the parameter `Store` and the machine terminal has been reset via the parameter `Software reset` in the menu `Configuration/General` or by using the relay command buttons **Store** and **Reset** in the Relay Download Tool.

5.1.5.

Auxiliary voltage

For its operation, the machine terminal, including the external display module, requires a secured auxiliary voltage supply. The machine terminal’s internal power supply module forms the voltages required by the machine terminal electronics. The power supply module is a galvanically isolated DC/DC converter. A green protection LED indicator on the front panel is lit when the power supply module is in operation.



The main unit and the external display module must each be provided with separate power supply from a common source.

The machine terminal is provided with a 48-hour capacitor back-up protection¹ that enables the internal clock to keep time in case of an auxiliary power failure.

5.1.5.1.

Power supply versions

The power supply module PS1/_ is available for REM 54_. The module is available in two versions with identical output voltages but different input voltages.

When REM 54_ is delivered with a fixed display module, the input voltage range of the power supply module is marked on the front panel of the machine terminal. When the machine terminal is provided with an external display module, the input voltage of the display module is marked on the front panel of the module and the input voltage of the main unit is marked on the side of the unit.

The external display module is only available together with a main unit equipped with the PS1/240 power supply module.¹

The power supply version is specified by the first letter in the order number of REM 54_ (refer to section “Ordering Information” on page 91). The voltage range of the digital inputs is tied to the selected power supply. If a power supply version with the higher rated input voltage is selected, the machine terminals will be delivered with digital inputs that also have the higher rated input voltage.

1. This function is only supported in Release 2.0 or later, refer to section “Revision identification” on page 93.

The auxiliary voltages of power supply modules and the corresponding rated input voltages of digital inputs are:

Power supply module	Rated input voltage of power supply	Rated input voltage of digital inputs
PS1/240	110/120/220/240 V AC or 110/125/220 V DC	110/125/220 V DC
PS1/48	24/48/60 V DC	24/48/60/110/125/220 V DC
External display module	110/120/220/240 V AC or 110/125/220 V DC	-

For further technical data of the power supply, refer to Table 5.2.1-2 on page 79.

5.1.5.2.

Low auxiliary voltage indication

The machine terminal is provided with a low auxiliary voltage indication feature. The power supply module issues an internal alarm signal when a drop in the power supply voltage is detected. The alarm signal is activated if the power supply voltage falls about 10% below the lowest rated DC input voltage of the power supply module, see the table below:

Rated input voltage	Low indication level
PS1/240	
• Rated input voltage 110/125/ 220 V DC	99 V DC
• Rated input voltage 110/120/220/ 240 V AC	88 V AC
PS1/48	
• Rated input voltage 24/48/60 V DC	21.6 V DC

The indication of a low auxiliary voltage is available in the machine terminal configuration environment and can be connected to any signal output of REM 54_. The auxiliary voltage indication in the machine terminal configuration is as follows:

REM 543: PS1_4_ACFail

REM 545: PS1_4_ACFail

5.1.5.3.

Overtemperature indication

The machine terminal includes an internal temperature supervision function. The power supply module issues an internal alarm signal when overtemperature has been detected inside the terminal enclosure. The alarm signal will be activated once the temperature inside the terminal enclosure increases to +78°C (+75...+83° C). Overtemperature indication is available in the machine terminal configuration and can be connected to any signal output of the terminal. The overtemperature indication input in the machine terminal configuration is as follows:

REM 543: PS1_4_TempAlarm

REM 545: PS1_4_TempAlarm

5.1.6. Analog channels

The machine terminal measures the analog signals needed for protection, measuring, etc. via sensors or galvanically separated matching transformers. The machine terminals can be provided with the following matching transformers:

- 5 current and 4 voltage transformers:
CT1, CT2, CT3, CT4, CT5, VT1, VT2, VT3, VT4
- 6 current and 3 voltage transformers:
CT1, CT2, CT3, CT4, CT5, CT6, VT1, VT2, VT3
- 7 current and 2 voltage transformers:
CT1, CT2, CT3, CT4, CT5, CT6, CT7, VT1, VT2
- 8 current and 1 voltage transformers:
CT1, CT2, CT3, CT4, CT5, CT6, CT7, CT8, VT1

In addition to conventional matching transformers, current sensors and voltage dividers developed by ABB can be used in the machine terminals. The machine terminal has 9 sensor inputs¹. A current sensor (Rogowski coil) or a voltage divider can be connected to each sensor input. The machine terminal allows the user to configure each sensor input for the type of sensor to be used. Furthermore, the machine terminal is provided with general measurement via sensor inputs. This allows e.g. temperature monitoring, provided a temperature sensor with a voltage transducer output is available.

The third letter in the four-letter extension of the order number specifies whether the machine terminal is to be equipped with conventional matching transformers or with matching transformers and sensor inputs. (See “Ordering Information” on page 91.).

- REM543C_212AA_A /CA_A /AA_B
- REM543B_213AA_A /CA_A /AA_B
- REM543C_214AA_A /CA_A /AA_B
- REM543B_215AA_A /CA_A /AA_B
- REM543C_216AA_A /CA_A /AA_B
- REM543B_217AA_A /CA_A /AA_B
- REM543C_218AA_A /CA_A /AA_B
- REM543B_219AA_A /CA_A /AA_B
- REM545B_222AA_A /CA_A /AA_B
- REM545B_223AA_A /CA_A /AA_B
- REM545B_224AA_A /CA_A /AA_B
- REM545B_225AA_A /CA_A /AA_B
- REM545B_226AA_A /CA_A /AA_B
- REM545B_227AA_A /CA_A /AA_B
- REM545B_228AA_A /CA_A /AA_B
- REM545B_229AA_A /CA_A /AA_B

1. Machine terminals of releases prior to Release 2.0 have 8 sensor channels.

Technical Reference Manual, General

The matching transformers and sensor inputs of the machine terminal are designed so as to allow either sensors or matching transformers to be used on the measuring channels 2...5 and 7...10. Should a matching transformer be used on a channel, no sensor is allowed to be used on the same channel or vice versa. On Channel 1, only sensors can be used and on Channel 6, only a matching transformer.

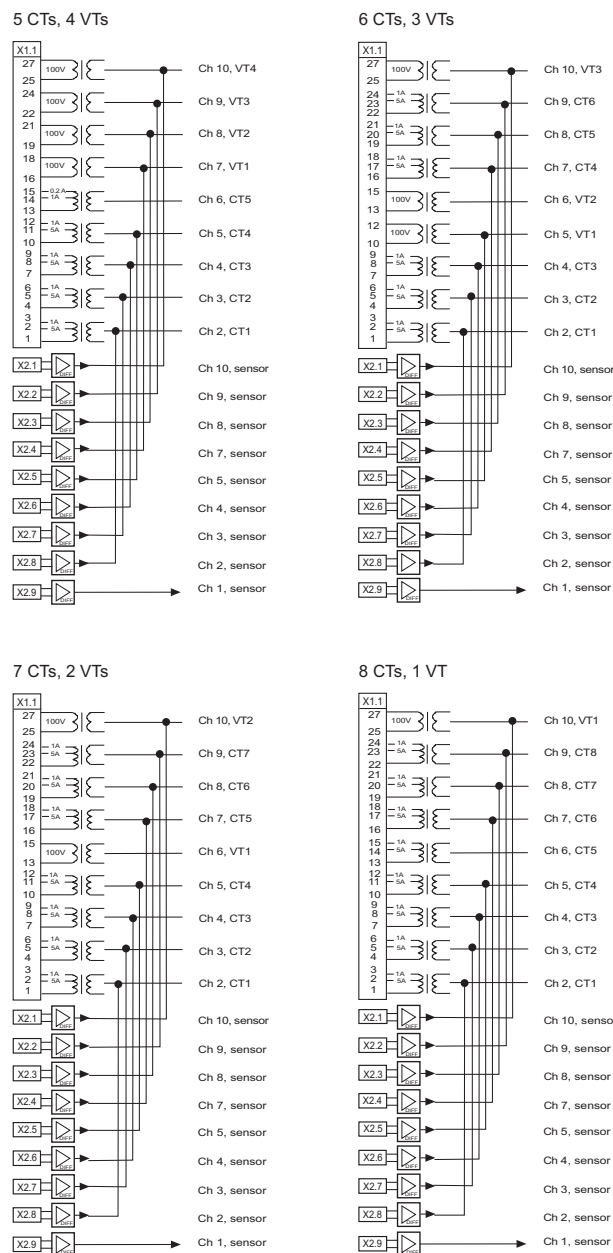

A060251

Fig. 5.1.6.-1 Analog channel configurations of REM 54_

Depending on whether sensors are included or not, the machine terminals have 9 (without sensors) or 10 (with sensors) physical analog channels (see the following table). The number of channels used depends on the machine terminal configuration and the kind of matching transformers or sensor inputs used. Furthermore, the

Technical Reference Manual, General

machine terminal includes virtual analog channels (refer to section “Calculated analog channels” on page 43) for calculating the neutral current and residual voltage from phase currents and voltages.

Each analog channel is separately configured with the Relay Configuration Tool. Both the measuring unit for each analog channel and the type of signal to be measured are to be configured.

Table 5.1.6-1 Physical analog channels of the machine terminals

Ch No.	Measuring units					
	Current Transformer (CT)	Voltage Transformer (VT)	Rogowski coil/sensor (RS)	Voltage divider (VD)	General measurement	Signal type (selectable alternatives)
1			RS 1...10	VD 1...10	Gen. meas. 1...3	Not in use, I _{L1} , I _{L2} , I _{L3} , I _{L1b} , I _{L2b} , I _{L3b} , U ₁ , U ₂ , U ₃ , U _{1b} , U _{2b} , U _{3b} , U _{1c} , GE1, GE2, GE3
2	Current Transformer CT1 (I _n = 1 A/5 A)		RS 1...10	VD 1...10	Gen. meas. 1...3	Not in use, I _{L1} , I _{L2} , I _{L3} , I _{L1b} , I _{L2b} , I _{L3b} , I ₀ , I _{0b} , U ₁ , U ₂ , U ₃ , U _{1b} , U _{2b} , U _{3b} , U _{1c} , GE1, GE2, GE3
3	Current Transformer CT2 (I _n = 1 A/5 A)					
4	Current Transformer CT3 (I _n = 1 A/5 A)					
5	Current Transformer CT4 (I _n = 1 A/5 A)	Voltage Transformer VT1 (U _n =100V/110V/115V/120V)	RS 1...10	VD 1...10	Gen. meas. 1...3	Not in use, I _{L1} , I _{L2} , I _{L3} , I _{L1b} , I _{L2b} , I _{L3b} , I ₀ , I _{0b} , U ₁₂ , U ₂₃ , U ₃₁ , U _{12b} , U _{23b} , U _{31b} , U _{12c} , U ₁ , U ₂ , U ₃ , U _{1b} , U _{2b} , U _{3b} , U _{1c} , U ₀ , U _{0b} , GE1, GE2, GE3
6	Current Transformer CT5 (I _n = 0.2 A/1 A)	Voltage Transformer VT1 or VT2 (U _n =100V/110V/115V/120V)				Not in use, I _{L1} , I _{L2} , I _{L3} , I _{L1b} , I _{L2b} , I _{L3b} , I ₀ , I _{0b} , U ₁₂ , U ₂₃ , U ₃₁ , U _{12b} , U _{23b} , U _{31b} , U _{12c} , U ₁ , U ₂ , U ₃ , U _{1b} , U _{2b} , U _{3b} , U _{1c} , U ₀ , U _{0b}
7	Current Transformer CT4, CT5 or CT6 (I _n = 1 A/5 A)	Voltage Transformer VT1 (U _n =100V/110V/115V/120V)	RS 1...10	VD 1...10	Gen. meas. 1...3	Not in use, I _{L1} , I _{L2} , I _{L3} , I _{L1b} , I _{L2b} , I _{L3b} , I ₀ , I _{0b} , U ₁₂ , U ₂₃ , U ₃₁ , U _{12b} , U _{23b} , U _{31b} , U _{12c} , U ₁ , U ₂ , U ₃ , U _{1b} , U _{2b} , U _{3b} , U _{1c} , U ₀ , U _{0b} , GE1, GE2, GE3
8	Current Transformer CT5, CT6 or CT7 (I _n = 1 A/5 A)	Voltage Transformer VT2 (U _n =100V/110V/115V/120V)				
9	Current Transformer CT6, CT7 or CT8 (I _n = 1 A/5 A)	Voltage Transformer VT3 (U _n =100V/110V/115V/120V)				
10		Voltage Transformer VT4 (U _n =100V/110V/115V/120V)	RS 1...10	VD 1...10	Gen. meas. 1...3	Not in use, I _{L1} , I _{L2} , I _{L3} , I _{L1b} , I _{L2b} , I _{L3b} , U ₁₂ , U ₂₃ , U ₃₁ , U _{12b} , U _{23b} , U _{31b} , U _{12c} , U ₁ , U ₂ , U ₃ , U _{1b} , U _{2b} , U _{3b} , U _{1c} , U ₀ , U _{0b} , GE1, GE2, GE3

The letters b and c after the signal type are used to distinguish between signals of the same type.

5.1.6.1.**Scaling the rated values of the protected unit for analog channel**

A separate scaling factor can be set for each analog channel. The factors enable differences between the ratings of the protected unit (generator, transformer, motor, etc.) and those of the measuring device (CTs, VTs, etc.) The setting value 1.00 means that the rated value of the protected unit is exactly the same as that of the measuring device.

When scaling factors are used, it should be noted that they affect the operation accuracy of the terminal. The accuracies stated in the function block manuals on CD-ROM Technical Descriptions of Functions only apply with the default values of the scaling factors. For example, a high factor affects the operation of sensitive protection functions such as the directional earth-fault protection.

The scaling factor is calculated channel by channel as follows:

Scaling factor = I_{nmd} / I_{np} , where

I_{nmd}	Rated primary current of the measuring device (A)
I_{np}	Rated primary current of the protected unit connected to the channel

Example:

Rated primary current of current trafo = 500 A:	$I_{nmd} = 500 \text{ A}$
Rated current of the protected unit = 250 A:	$I_{np} = 250 \text{ A}$
Scaling factor for current channels:	$500 \text{ A} / 250 \text{ A} = 2.00$



The scaling factor is not used for general measurement signals connected to the analog channel.

The scaling factors for the analog channels can be set via the HMI of the machine terminal or with the Relay Setting Tool. The HMI path for the scaling factors is: Main Menu/Configuration/Protected Unit/Ch 1: scaling, Ch 2: scaling...

5.1.6.2.**Technical data of the measuring devices**

When the machine terminal is configured, the technical data of the measuring devices is set in separate dialog boxes in the Relay Configuration Tool. The set values will affect the measurements carried out by the machine terminal.

For storing the values listed below, refer to section “Storing of parameters and recorded data” on page 34. Values to be set for a current transformer are:

- rated primary current (0...6000 A) of the primary current transformer
- rated secondary current (5 A, 2 A, 1 A, 0.2 A) of the primary current transformer
- rated current (5 A, 1 A, 0.2 A) of the current measuring input (= rated current of the matching transformer of the machine terminal)
- amplitude correction factor (0.9000...1.1000) of the primary current transformer at rated current
- correction parameter for the phase displacement error of the primary current transformer at rated current (-5.00° ... 0.00°)
- amplitude correction factor of the primary current transformer at a signal level of 1% of the rated current (0.9000...1.1000)
- correction parameter for the phase displacement error of the primary current transformer at a signal level of 1% of the rated current (-10.00° ... 0.00°)

Values to be set for a voltage transformer are:

- rated voltage of voltage input (same as the secondary rated voltage of the primary voltage transformer connected to the voltage input, 100 V, 110 V, 115 V, 120 V)
- rated voltage of primary voltage transformer (0...440 kV)
- amplitude correction factor of the primary voltage transformer voltage at rated voltage (0.9000...1.1000)
- correction parameter for the primary transformer phase displacement error at rated voltage (-2.00° ... 2.00°)

Values to be set for a current sensor (Rogowski coil) are:

- secondary rated voltage of the current sensor used at the preset primary rated current (0...300 mV)
- primary rated current of the current sensor used (0...6000 A)
- amplitude correction factor of the current sensor used at rated current (0.9000...1.1000)
- correction parameter for the phase displacement error of the current sensor (-1.0000° ... 1.0000°)¹

1. Only included in Release 2.0 or later, refer to section “Revision identification” on page 93. Note that this parameter can only be set via the HMI or the Relay Setting Tool.

Values to be set for a voltage divider are:

- division ratio of the voltage divider primary and secondary voltage (0...20000)
- rated value of primary phase-to-phase voltage (0...440 kV)
- amplitude correction factor of the voltage divider (0.9000...1.1000)
- correction parameter for the phase displacement error of the voltage divider ($-1.0000^\circ \dots 1.0000^\circ$)¹

Values to be set for general measurement:²

- amplitude correction factor of general measurement (-10000.00000...10000.00000)
- correction parameter for the offset correction of general measurement (-10000.00000...10000.00000)

The measurement values stated by the manufacturer of the measuring device are used for calculating the correction parameters and factors according to the following formulas:

Current transformers

Amplitude error at current I_n (e = error in per cent)	Amplitude correction factor 1 $= 1 / (1 + e/100)$
Amplitude error at current $0.01 \times I_n$ (e = error in per cent)	Amplitude correction factor 2 $= 1 / (1 + e/100)$
Phase displacement error at current I_n (e = error in degrees)	Phase displacement error 1 = - e
Phase displacement error at current $0.01 \times I_n$ (e = error in degrees)	Phase displacement error 2 = - e

Voltage transformers

Amplitude error at voltage U_n (e = error in per cent)	Amplitude correction factor $= 1 / (1 + e/100)$
Phase displacement error at voltage U_n (e = error in degrees)	Phase displacement error = - e

Rogowski coil

Amplitude error at the whole measuring range (e = error in per cent)	Amplitude correction factor $= 1 / (1 + e/100)$
Phase displacement error at the whole measuring range (e = error in degrees)	Phase displacement error = - e

Voltage divider

Amplitude error at the whole measuring range (e = error in per cent)	Amplitude correction factor $= 1 / (1 + e/100)$
Phase displacement error at the whole measuring range (e = error in degrees)	Phase displacement error = - e

1. Only included in Release 2.0 or later, refer to section "Revision identification" on page 93. Note that this parameter can only be set via the HMI or the Relay Setting Tool.
2. Only included in Release 2.0 or later, refer to section "Revision identification" on page 93.

5.1.6.3. Calculated analog channels

The machine terminal includes virtual channels to obtain neutral current and residual voltage when sensors are used. Current sensors and voltage dividers are connected to the machine terminal via coaxial cables and therefore a residual connection of phase currents or an open-delta connection of phase voltages cannot be made. Both the amplitude and the phase angle are calculated for the virtual channels.

Though primarily meant to be used with sensors, the calculated analog channels can also be used with conventional current and voltage transformers.

The neutral current I_0 is numerically derived from the three phase currents: $I_{os} = -(I_{L1} + I_{L2} + I_{L3})$. Minus in front of the parenthesis means that the default direction of neutral current is assumed to be from the line to the busbar, while the normal power flow is from the busbar to the line.



When sensitive earth-fault protection is needed, core balance transformers are not recommended to be replaced with the numerically derived sum of phase currents. Normally, an earth-fault setting below 10% of the rated value requires the use of a core balance transformer.

The residual voltage U_0 is numerically derived from the three phase voltages: $U_{os} = (U_1 + U_2 + U_3) \div 3$. U_{0S} is used instead of the open-delta connection when voltage dividers are used to measure phase-to-earth voltages.

If only one virtual channel is used, the channel will be numbered as 11. If both calculations are used, the I_{0S} channel will be given the number 11 and the U_{0S} channel the number 12.

5.1.7. Digital inputs

The REM 543 and REM 545 machine terminals differ from each other regarding the number of digital inputs available.

The digital inputs of the REM 54_ machine terminals are voltage-controlled and optically isolated. For technical data of the digital inputs, refer to Table 5.2.1-3 on page 79.

The parameters for input filtering, input inversion and pulse counters (see sections below) can be set in the `Configuration` menu under each I/O card (e.g. `Configuration/BIO1/Input filtering`).

The events and parameters of I/O cards are included in the event and parameter lists on the CD-ROM Technical Descriptions of Functions.

Table 5.1.7-1 Digital inputs available for REM 54_

	REM 543	REM 545
Inputs	PS1_4_BI1 ^a	PS1_4_BI1 ^a
	PS1_4_BI2 ^a	PS1_4_BI2 ^a
	PS1_4_BI3 ^a	PS1_4_BI3 ^a
	BIO1_5_BI1	BIO1_5_BI1
	BIO1_5_BI2	BIO1_5_BI2
	BIO1_5_BI3	BIO1_5_BI3
	BIO1_5_BI4	BIO1_5_BI4
	BIO1_5_BI5	BIO1_5_BI5
	BIO1_5_BI6	BIO1_5_BI6
	BIO1_5_BI7	BIO1_5_BI7
	BIO1_5_BI8	BIO1_5_BI8
	BIO1_5_BI9 ¹⁾	BIO1_5_BI9 ^a
	BIO1_5_BI10 ^a	BIO1_5_BI10 ^a
	BIO1_5_BI11 ^a	BIO1_5_BI11 ^a
	BIO1_5_BI12 ^a	BIO1_5_BI12 ^a
		BIO2_7_BI1
		BIO2_7_BI2
		BIO2_7_BI3
		BIO2_7_BI4
		BIO2_7_BI5
		BIO2_7_BI6
		BIO2_7_BI7
		BIO2_7_BI8
		BIO2_7_BI9 ¹⁾
		BIO2_7_BI10 ¹⁾
Digital inputs / total	15	25

a. These digital inputs can be programmed as either digital inputs or pulse counters, refer to section "Pulse counters" on page 46.

5.1.7.1. Filter time of a digital input

The filter time eliminates debounces and short disturbances on a digital input. The filter time is set for each digital input of the terminal. The operation of input filtering is illustrated below.

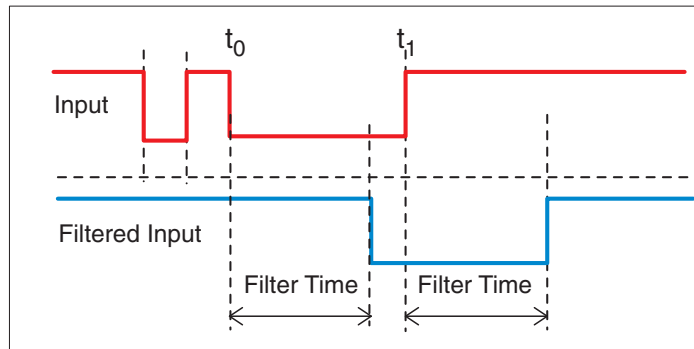

dipo_b

Fig. 5.1.7.1.-1 Filtering of a digital input

In the figure above, the input signal is named 'Input', the filter timer 'Filter Time' and the filtered input signal 'Filtered Input'. At the beginning, the input signal is at high state, the short low state is filtered and no input status change is detected. The low state starting from the time t_0 exceeds the filter time, which means that the change in the input status is detected and the time tag attached to the input change is t_0 . The high state starting from t_1 is detected and the time tag t_1 is attached.

Each digital input has a filter time parameter `Input # filter`, where # is the number of the digital input of the module in question (e.g. `Input 1 filter`).

Parameter	Values	Default
Input # filter	1...15000 ms ^a	5 ms

a. Prior to Release 2.5: 1...65535 ms.

5.1.7.2. Inversion of a digital input

The parameter `Input # invert` can be used to invert a digital input:

Control voltage	Input # invert	Status of digital input
No	0	FALSE (0)
Yes	0	TRUE (1)
No	1	TRUE (1)
Yes	1	FALSE (0)

When the digital input is inverted, the status of the input is TRUE (1) when no control voltage is applied to its terminals. Accordingly, the input status is FALSE (0) when a control voltage is applied to the terminals of the digital input.

Parameter	Values	Default
Input # invert	0 (not inverted)	0
	1 (inverted)	

5.1.7.3.

Pulse counters

Some specific digital inputs (refer to section “Digital inputs” on page 43) of the terminal can be programmed either as digital inputs or as pulse counters. This programming is done via the parameter `Input # mode` (in this parameter as well as in others mentioned below, # denotes the input number).

When an input operates as a digital input, no counting is done but the pulse counter value remains at the present value.

When an input operates as a pulse counter, the positive input transitions (0 -> 1) of a filtered input are counted and the counter value of `Input # counter` increases in the range 0... 2147483647. The pulse counters are updated with a period of 500 ms. The frequency range of a digital input parameterized to operate as a pulse counter is 0...100 Hz.

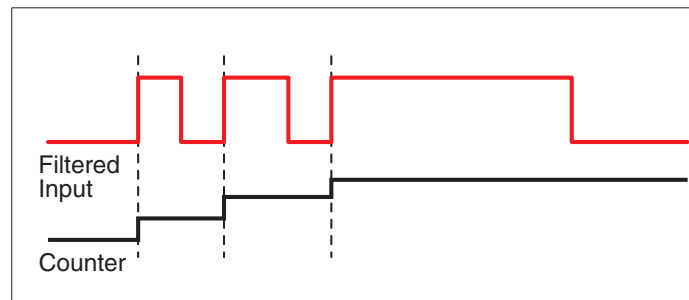

dipo2_b

Fig. 5.1.7.3.-1 Principle of pulse counter function

The parameter `Input # preset` can be used to give a counter the start value. The start value is loaded into the counter by:

- writing the desired start value to the parameter `Input # preset`,
- writing the value 1 to the parameter `Counter trigger`. Then all the updated values of the `Input # preset` parameters are copied to the corresponding `Input # counter` parameters.

Writing the value 2 to the `Counter trigger` parameter copies all the `Input # preset` values to the corresponding `Input # counter` parameters. Writing the value 0 clears all the counters.

Parameter	Values	Default
<code>Input # preset</code>	0.... 2147483647	0
<code>Input # mode</code>	1 = digital input 2 = counter	1
<code>Counter trigger</code>	0 = clear all counters 1 = load updated <code>Input # preset</code> values 2 = load all <code>Input # preset</code> values	

5.1.7.4.**Oscillation suppression**

Oscillation suppression is used to reduce the load from the system when, for some unrecognized reason, a digital input starts oscillating. A digital input is regarded as oscillating if the number of valid status changes (= number of events after filtering) during 1 second is greater than the set value `Input osc. level` (Oscillation level). During oscillation, the digital input is blocked (status is invalid) and an event is generated. The state of the input will not change when it is blocked, i.e. its state depends on the condition before blocking.

The digital input is regarded as non-oscillating if the number of valid status changes during 1 second is less than the set value of `Input osc. level` minus the set value of `Input osc. hyst.` (Oscillation hysteresis). Note that the oscillation hysteresis must be set lower than the oscillation level to enable the input to be restored from oscillation. When the input returns to a non-oscillating state, the digital input is deblocked (status is valid) and an event is generated.

Parameter	Values	Default
<code>Input osc. level</code>	2...50 events/s	50 events/s
<code>Input osc. hyst.</code>	2...50 events/s	10 events/s



Unlike most parameters for digital I/O cards, the parameters `Input osc. level` and `Input osc. hyst.` can be found in the menu `Configuration/General`.

5.1.7.5.**Attributes of a digital input for machine terminal configuration**

The validity of the digital input (invalidity), the status of the input (value), the time tag for the status change (time) and the counter value of the input can be issued for each digital input by the attributes `BI#IV`, `BI#`, `BI#Time` and `BI#Count`, where # denotes the number of the input. These attributes are available in the machine terminal configuration and can be used for different purposes.

The example below shows how the attributes of the digital input 1 (`PS1_4_BI1` on PS1 module) of the machine terminal are named for the configuration:

`PS1_4_BI1IV`; digital input invalidity

`PS1_4_BI1`; digital input value

`PS1_4_BI1Time`; time tag

`PS1_4_BT1Count`; counter value

Invalidity (BI#IV)

When a digital input oscillates, the invalidity attribute `IV` changes to `TRUE` (1) and the input is blocked. The digital input is regarded as being blocked and oscillating if the number of status changes per second exceeds the set `Input osc. level` value (events/s).

When a digital input does not oscillate, the invalidity attribute `IV` changes to `FALSE` (0) and the input becomes operative. The digital input is regarded as being operative and non-oscillating if the number of status changes per second is less than the set `Input osc. level` value minus the set `Input osc. hyst. value` (events/s).

Value (BI#)

Depending on the status of the digital input, the digital input value is TRUE (1) or FALSE (0). The BI# value changes on the rising or falling edge of the input. To prevent undesired status changes of the digital input due to switch debouncing, etc., the change of the attribute value is delayed by the filter time.

The counter attribute of a digital input is not updated when the input is programmed as a normal digital input.

Time (BI#Time)

Each change (rising or falling edge) detected in the status of a digital input is time-tagged at an accuracy of ± 1 ms. The time tag represents the moment (time) of the latest input change of the value attribute. The time is not recorded until the filtering time of the status change has elapsed, which means that the filtering time does not affect the time tag value.

Count (BI#Count)

The count attribute indicates the number of positive input transitions of a filtered input.

5.1.8.**Digital outputs**

The outputs of the machine terminal are categorized as follows:

HSPO	High-speed power output, double-pole contact, preferred for tripping purposes and for circuit breaker and disconnect control
PO	Power output, either single-pole or double-pole contact, preferred for circuit breaker and disconnect control
SO	Signal output, either NO (Normally Open) or NO/NC (Normally Open/ Normally Closed) contact

The events and parameters of I/O cards are included in the event and parameter lists on the CD-ROM Technical Descriptions of Functions (see “Related documents” on page 8).

For information about terminal connections for the outputs, refer to terminal diagrams (beginning on page 84), where all the outputs are included with relay connector terminals.

For technical data of the outputs, see Table 5.2.1-6 on page 80.

Table 5.1.8-1 Digital outputs

	REM 543	REM 545
Outputs	PS1_4_HSPO1 ^a	PS1_4_HSPO1 ^a
	PS1_4_HSPO2 ^a	PS1_4_HSPO2 ^a
	PS1_4_HSPO3	PS1_4_HSPO3
	PS1_4_HSPO4	PS1_4_HSPO4
	PS1_4_HSPO5	PS1_4_HSPO5
	PS1_4_SO1	PS1_4_SO1
	BIO1_5_SO1	BIO1_5_SO1
	BIO1_5_SO2	BIO1_5_SO2
	BIO1_5_SO3	BIO1_5_SO3
	BIO1_5_SO4	BIO1_5_SO4
	BIO1_5_SO5	BIO1_5_SO5
	BIO1_5_SO6	BIO1_5_SO6
		BIO2_7_PO1
		BIO2_7_PO2
		BIO2_7_PO3
		BIO2_7_PO4
		BIO2_7_PO5
		BIO2_7_PO6
Outputs / total	12	18

a. Trip Circuit Supervision function included

5.1.8.1.

High-speed double-pole power outputs (HSPO)

The high-speed power outputs PS1_4_HSPO1... PS1_4_HSPO5 can be connected as double-pole outputs where the object to be controlled (e.g. a circuit breaker) is electrically connected between the two relay contacts, see the figure below. The high-speed double-pole power output is recommended to be used for tripping purposes.



When TCS is used (see Table 5.1.8-1 on page 49), the outputs are connected as shown in Figure 5.1.11.-1 on page 64.

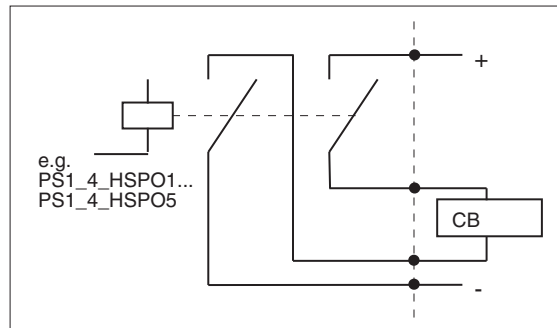

cbcoil_b

Fig. 5.1.8.1.-1 High-speed double-pole power outputs (HSPO)

The high-speed power outputs PS1_4_HSPO1... PS1_4_HSPO5 can also be connected as single-pole power outputs where the object to be controlled (e.g. a circuit breaker) is electrically connected in series with the two relay contacts, see the figure below.

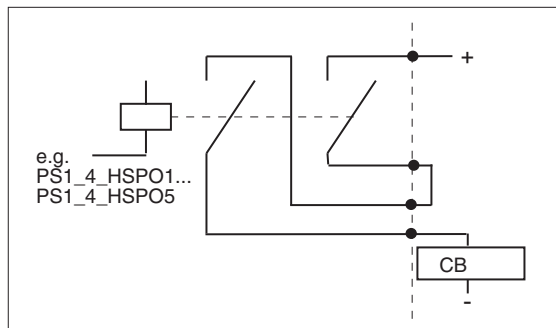

doubpole_b

Fig. 5.1.8.1.-2 High-speed single-pole power outputs (HSPO)

5.1.8.2.

Single-pole power outputs (PO)

The single-pole power outputs BIO2_7_PO1 and BIO2_7_PO2 are outputs where the object to be controlled is connected in series with two heavy-duty output relay contacts, see the figure below. These outputs can be used for tripping purposes and for circuit breaker and disconnector control.

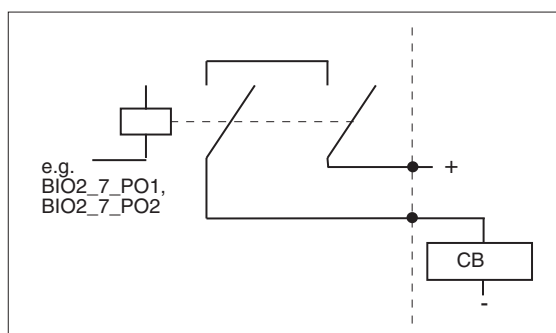

PO1conn_b

Fig. 5.1.8.2.-1 Single-pole power outputs (PO)

Double-pole power outputs (PO)

The double-pole power outputs BIO2_7_PO3... BIO2_7_PO6 are outputs where the object to be controlled (e.g. a circuit breaker) is electrically connected between the two relay contacts, see the figure below. These outputs can be used for tripping purposes and for circuit breaker and disconnector control.

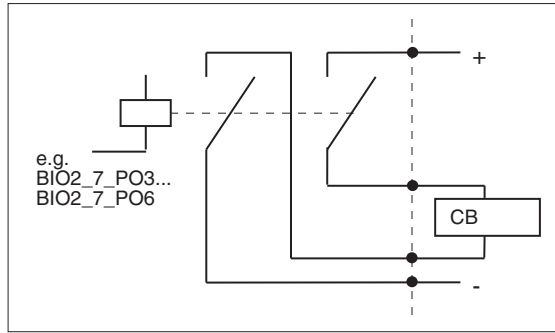

PO3conn_b

Fig. 5.1.8.2.-2 Double-pole power outputs (PO)

If the power outputs BIO2_7_PO3... BIO2_7_PO6 are used as single-pole outputs, the object to be controlled is electrically connected in series with the two relay contacts to provide sufficient breaking capacity, see the following figure.

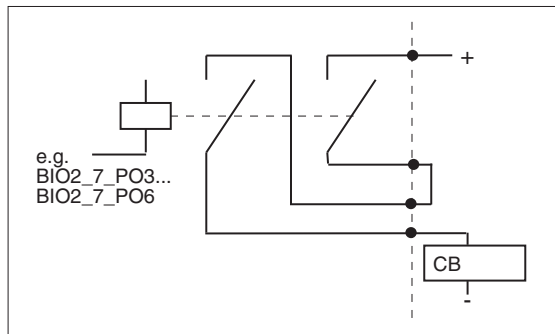

PO2conn_b

Fig. 5.1.8.2.-3 Single-pole power outputs (PO)

Signal outputs (SO)

The signalling relay outputs (BIO1_5_SO_) are not heavy-duty outputs and thus they cannot be used for controlling for example a circuit breaker. Available relay contacts are either Normally Open or Normally Open/Normally Closed type (NO or NO/NC), see the following figure. These outputs can be used for alarming and other signalling purposes.

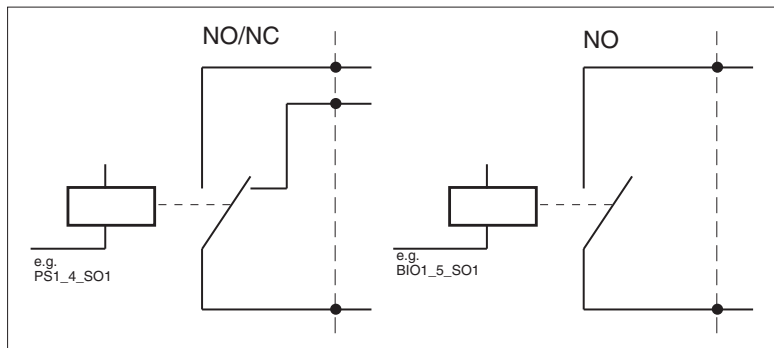

nonc_b

Fig. 5.1.8.2.-4 Signal outputs (SO)

5.1.9. RTD/analog inputs

The machine terminals equipped with an RTD/analog module (RTD1) have eight general purpose analog inputs for DC measurement. The RTD/analog inputs are galvanically isolated from the machine terminal power supply and enclosure. However, the inputs share a common ground.

For technical data of the RTD/analog inputs, refer to Table 5.2.1-4 on page 80.

	REM 543/REM 545 + RTD1
RTD/analog inputs	RTD1_6_AI1
	RTD1_6_AI2
	RTD1_6_AI3
	RTD1_6_AI4
	RTD1_6_AI5
	RTD1_6_AI6
	RTD1_6_AI7
	RTD1_6_AI8

The parameters for the RTD/analog inputs are included in the parameter lists on the CD-ROM Technical Descriptions of Functions (see “Related documents” on page 8).

5.1.9.1. Selection of input signal type

The general purpose RTD/analog inputs accept voltage-, current- or resistance-type signals. The inputs are configured for a particular type of input signal by means of the channel-specific “Input mode” parameters that can be found in the menu Configuration/RTD1/Input #. The default value is “Off” which means that the channel is not sampled at all, and the IN+, IN- and SHUNT terminals are at high impedance state.

Parameter	Values	Default
Input mode	0 = Off	Off
	1 = Voltage	
	2 = Current	
	3 = Resistance 2W ^a	
	4 = Resistance 3W ^b	
	5 = Temperature 2W ^a	
	6 = Temperature 3W ^b	

- a. Two-wire measurement
- b. Three-wire measurement

5.1.9.2. Selection of input signal range

For each measuring mode, a separate parameter is provided for choosing between the available measurement ranges. These channel-specific parameters, which can be found in the menu Configuration/RTD1/Input #, are named Voltage range, Current range, Resistance range and Temperature range.

Technical Reference Manual, General

All range parameters can be set but only one is used. The value of the Input mode parameter determines which range parameter is used. The Temperature range parameter also defines the sensor type to be used, e.g. PT100.

Parameter	Values	Default
Voltage range	0 = 0...1V	0...1 V
	1 = 0...5 V	
	2 = 1...5 V	
	3 = 0...10 V	
	4 = 2...10 V	
	5 = -5...5 V	
	6 = -10...10 V	
Current range	0 = 0...1 mA	0...1 mA
	1 = 0...5 mA	
	2 = 1...5 mA	
	3 = 0...10 mA	
	4 = 0...20 mA	
	5 = 4...20 mA	
	6 = -1...1 mA	
	7 = -2.5...2.5 mA	
	8 = -5...5 mA	
	9 = -10...10 mA	
	10 = -20...20 mA	
Resistance range	0 = 0...100 Ω	0...100 Ω
	1 = 0...200 Ω	
	2 = 0...500 Ω	
	3 = 0...1000 Ω	
	4 = 0...2000 Ω	
	5 = 0...5000 Ω	
	6 = 0...10000 Ω	
Temperature range	0 = Pt100 -45...150 °C	Pt100 -45...150 °C
	1 = Pt100 -45...600 °C	
	2 = Pt250 -45...150 °C	
	3 = Pt250 -45...600 °C	
	4 = Pt1000 -45...150 °C	
	5 = Pt1000 -45...600 °C	
	6 = Ni100 -45...150 °C	
	7 = Ni100 -45...250 °C	
	8 = Ni120 -45...150 °C	
	9 = Ni120 -45...250 °C	
	10 = Ni250 -45...150 °C	
	11 = Ni250 -45...250 °C	
	12 = Ni1000 -45...150 °C	
	13 = Ni1000 -45...250 °C	
	14 = Cu10 -45...150 °C	
	15 = Ni120US -45...150 °C ^a	
16 = Ni120US -45...250 °C ^a		

a. In Release 2.5 or later

5.1.9.3. Transducer supervision

The measuring signal level of each transducer is constantly supervised. If the measured signal falls more than 4% below or rises more than 4% over the specified input signal range of a particular channel, the transducer or the transducer wiring is considered to be faulty and the channel-specific invalid signal is immediately activated. The invalid signal is deactivated as soon as the transducer signal is within the valid range.

When necessary, the valid measuring range may be narrower than the default -4...104% of the selected measuring range. A narrower range can be defined by means of the parameters `Input high limit` and `Input low limit` that can be found in the menu `Configuration/RTD1/Input #`.

Parameter	Values	Default
Input low limit	-4...104%	-4%
Input high limit	-4...104%	104%

When an input is configured for resistance or temperature measurement, the internal excitation current generator forces a current pulse through the measuring circuit when the input is sampled. If the actual current level does not match the programmed level due to too high impedance in the circuit, the invalid signal is immediately activated. The invalid signal is deactivated as soon as the circuit resistance is low enough.

5.1.9.4. Signal filtering

Short disturbances on an input are eliminated by signal filtering. The filter time, which defines the step response time, is set for each transducer input of the machine terminal by the `Filter time` parameters in the menu `Configuration/RTD1/Input #`. The filtering algorithm is a so-called median filter which shows no reaction to interference spikes but levels out directly on permanent changes.

Parameter	Values	Default
Filter time	0 = 0.4 s 1 = 1 s 2 = 2 s 3 = 3 s 4 = 4 s 5 = 5 s	5 s

5.1.9.5. Input scaling/linearization ¹

The user can scale each RTD/analog input linearly or non-linearly by constructing a separate linearization curve for each input. The name implies the typical use, i.e. the linearization of not directly supported non-linear sensors. The curve consists of at least two (for linear scaling) and up to ten points, where the x-axis of the curve is 0

1. Not supported yet

to 1000 per mille of the range selected for the input and the y-axis is the scaled absolute value of the input. The linearization curves can be enabled and disabled with the `Linear. curve` parameters in the menu `Configuration/RTD1/ Input #`. The curve is constructed and downloaded to the machine terminal by using a special tool in the relay toolbox.

Parameter	Values	Default
Linear. curve	0 = Disabled 1 = Enabled	Disabled

When the linearization curve is enabled, the `Input high limit` and `Input low limit` parameters affect the scaled range instead of the range selected by the parameters. The range of the scaled input is defined as the range between the smallest y-axis value and the largest y-axis value.

5.1.9.6. Transducer connections

The RTD/analog inputs may be connected to a large variety of different measuring transducer types, both standardized and customer-specified types.

Three connection screws have been reserved for each channel. Further, one connection screw (analog ground) has been reserved per every two channels.

Two earth terminals (see figure below), located to the left of the connectors, are reserved for connecting the protective sheaths of the transducer input cables. The cable sheath is generally earthed in one end of the cable only.

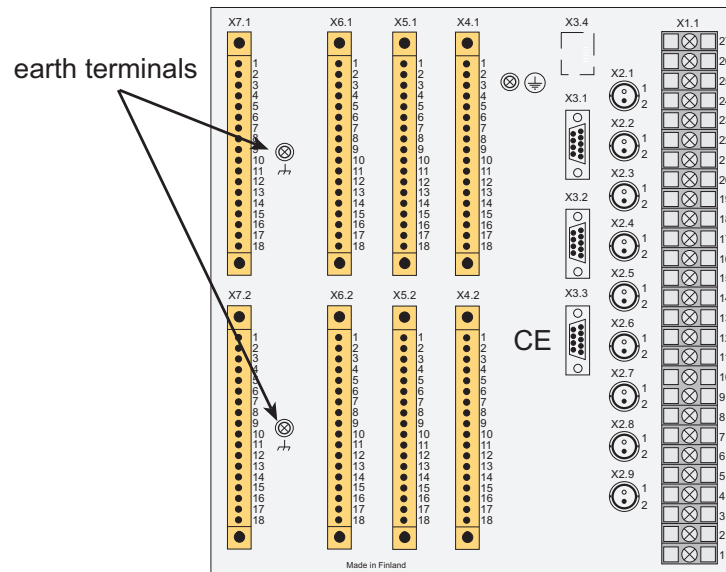

A060252

Fig. 5.1.9.6.-1 Earth terminals

Current transducers

When a current transducer is connected to the RTD/analog input, the SHUNT and IN+ terminals are linked together as are the GND and IN- terminals. The incoming current signal is connected to the IN+ terminal and the outgoing current signal to the IN- terminal.

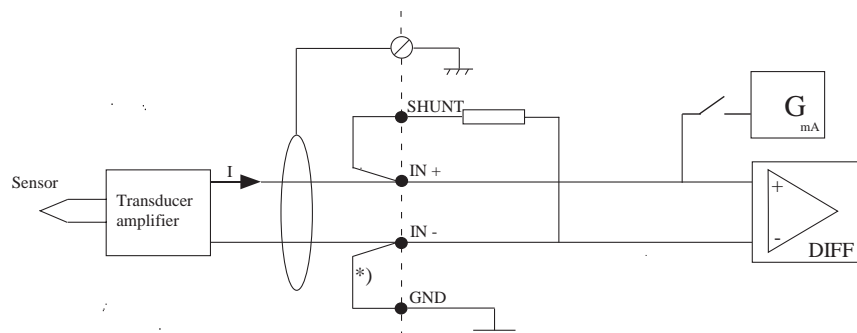

curtran_b

Fig. 5.1.9.6.-2 Principle diagram for the connection of current transducers

Voltage transducers

When a voltage transducer is connected to the RTD/analog input, the GND and IN- terminals are linked together. The incoming voltage signal is connected to the IN+ terminal and the return voltage signal lead to the IN- terminal.

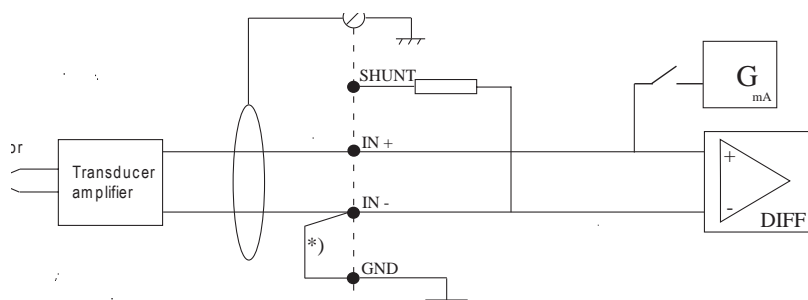

voltran_b

Fig. 5.1.9.6.-3 Principle diagram for the connection of voltage transducers

*) The GND terminals are galvanically isolated from the supply and enclosure of the machine terminal, but they are all connected to each other, i.e. they share the same potential. When several inputs are connected to single-ended signal sources that share a common ground, ground loops result if the connection GND <-> IN- is done on every input. In this situation, the connection GND <-> IN- is done on only one of the concerned RTD/analog inputs.

Resistance sensors

The resistance sensors may be connected to the RTD/analog input according to either the three-wire or the two-wire connection principle. With the three-wire measuring principle, the wire resistance is automatically compensated. The resistor, or RTD sensor, is connected across the IN+ and IN- inputs, and the - side of the resistor/RTD sensor is connected to the GND input. The leads connected to the IN+ and GND inputs must be of the same type.

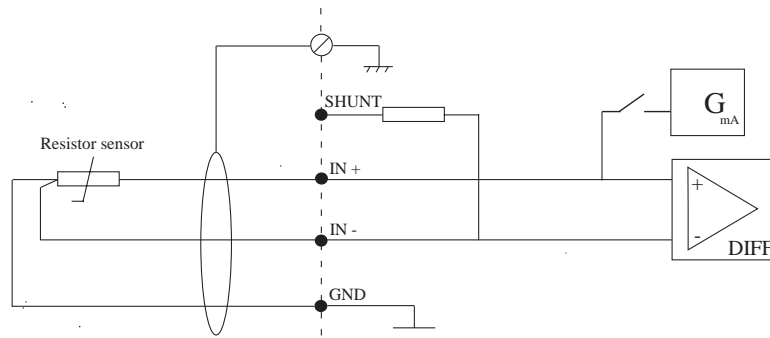

resist3w_b

Fig. 5.1.9.6.-4 Principle diagram of the three-wire connection

With the two-wire connection principle, the IN- and GND terminals are linked together. The resistor is connected across the IN+ and IN- inputs.

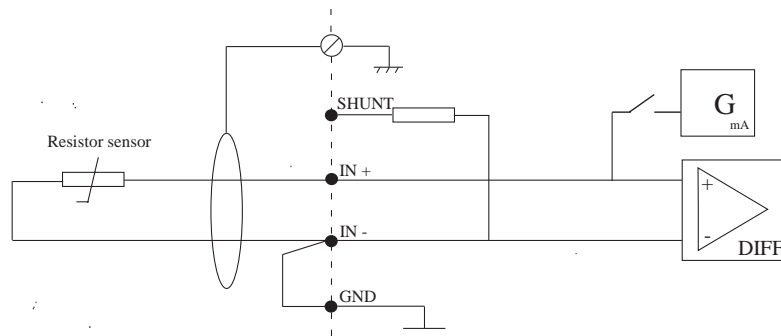

resist2w_b

Fig. 5.1.9.6.-5 Principle diagram of the two-wire connection

5.1.9.7.

Attributes of an RTD/analog input for machine terminal configuration

The value and the status (validity) of the input can be issued for each RTD/analog input by the attributes AI# (REAL type) and AI#IV (BOOL type), where # denotes the number of the input. These attributes are available in the machine terminal configuration and can be used for different purposes.

Value (AI#)

The AI# value represents the filtered absolute value of the physical input with the unit according to the selected measuring mode, i.e. V, mA, Ω or $^{\circ}\text{C}$.

Invalidity (AI#IV)

The AI#IV attribute represents the invalidity status of the input. The attribute is set to FALSE when the value (AI#) is valid, and to TRUE when the value is invalid. The input is invalid when one or more of the following conditions are true: the measured value is outside the defined limits (see the parameters `Input high limit` and `Input low limit`), an open-loop condition is detected (only possible on resistance and temperature measuring modes) or the continuous recalibration of the module has failed. The value (AI#) is not locked when the invalid attribute is set to TRUE, i.e. the invalid value is available for inspection.

5.1.9.8. RTD/analog input configuration example

The RTD/analog inputs are supported in the Relay Configuration Tool by the general measurement function blocks MEAI1...MEAI8. As an example, to monitor temperature using a PT100 sensor, the measured value of the RTD/analog input is connected to the function block by connecting the value attribute RTD1_6_AI1 to the RawAI input of the function block. The output HighAlarm is used to activate a relay contact when the temperature exceeds a preset limit. The measured temperature is displayed on the MIMIC view of the HMI by the connected MMIDATA1 function block. To avoid unnecessary activation of the relay contact in case of a fault, the corresponding invalid attribute of the RTD/analog input RTD1_6_AI1IV is connected to the IV input of the function block.

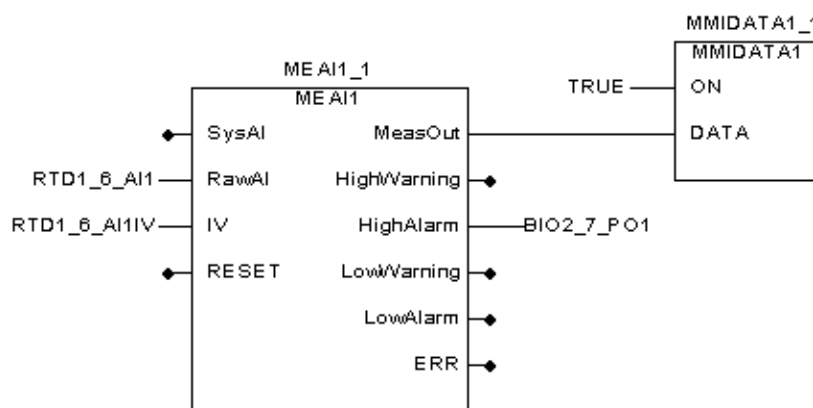

A060253

Fig. 5.1.9.8.-1 RTD/analog input configuration example

5.1.9.9. Self-supervision

Each input sample is validated before it is fed into the filter algorithm. The samples are validated by measuring an internally set reference voltage immediately after the inputs are sampled. If the measured offset voltage deviates from the set value more than 1.5% of the measuring range, the sample is discarded. If the fault continues longer than for the set filter time, the invalid attributes of all inputs are set to TRUE to indicate a hardware fault. Should the measurement succeed later, the invalid attributes are reset to FALSE. This prevents most sudden hardware faults from affecting the measured value before the invalid attribute is set. To ensure that the specified measurement accuracy is met, a more thorough test of the hardware is performed by the continuous recalibration procedure which will catch errors that degrade the measurement accuracy.

5.1.9.10.**Calibration**

The RTD/analog module is calibrated at the factory. To be able to maintain the specified accuracy in spite of aging and varying temperature, the card also includes special hardware to allow self-recalibration on the field. This recalibration procedure runs continuously, even when no measurements are activated, to ensure that the card is always optimally calibrated. If the recalibration procedure fails, the reason is a hardware failure. In this case the card's measurement accuracy is no longer obtained, and the invalidity attributes of all inputs are set to TRUE. However, the card continues updating the measured input values, and if the invalidity attributes are not used in the machine terminal configuration, the situation could go unnoticed. Should the recalibration succeed later, the invalidity attributes return to normal operation.

Technical Reference Manual, General

5.1.9.11. RTD temperature vs. resistance

For the resistance values (in Ohms) of temperature sensors at specified temperatures, see the table below.

TEMP C°	Platinum TCR 0.00385			Nickel TCR 0.00618				Copper TCR 0.00427	Nickel TCR 0.00672
	Pt 100	Pt 250	Pt 1000	Ni 100	Ni 120	Ni 250	Ni 1000	Cu 10	Ni 120US
-40.0	84.27	210.68	842.7	79.1	94.92	197.75	791	7.49	92.76
-30.0	88.22	220.55	882.2	84.1	100.92	210.25	841	-	-
-20.0	92.16	230.4	921.6	89.3	107.16	223.25	893	8.26	106.15
-10.0	96.09	240.23	960.9	94.6	113.52	236.5	946	-	-
0.0	100.00	250	1000	100.0	120	250	1000	9.04	120.00
10.0	103.90	259.75	1039	105.6	126.72	264	1056	-	-
20.0	107.79	269.48	1077.9	111.2	133.44	278	1112	9.81	134.52
30.0	111.67	279.18	1116.7	117.1	140.52	292.75	1171	-	-
40.0	115.54	288.85	1155.4	123.0	147.6	307.5	1230	10.58	149.79
50.0	119.40	298.5	1194	129.1	154.92	322.75	1291	-	-
60.0	123.24	308.1	1232.4	135.3	162.36	338.25	1353	11.352	165.90
70.0	127.07	317.68	1270.7	141.7	170.04	354.25	1417	-	-
80.0	130.89	327.23	1308.9	148.3	177.96	370.75	1483	12.12	182.84
90.0	134.70	336.75	1347	154.9	185.88	387.25	1549	-	-
100.0	138.50	346.25	1385	161.8	194.16	404.5	1618	12.90	200.64
120.0	146.06	365.15	1460.6	176.0	211.2	440	1760	13.67	219.29
140.0	153.58	383.95	1535.8	190.9	229.08	477.25	1909	14.44	238.85
150.0	-	-	-	198.6	238.32	496.5	1986	-	-
160.0	161.04	402.6	1610.4	206.6	247.92	516.5	2066	15.22	259.30
180.0	168.46	421.15	1684.6	223.2	267.84	558	2232	-	280.77
200.0	175.84	439.6	1758.4	240.7	288.84	601.75	2407	-	303.46
220.0	-	-	-	259.2	311.04	648	2592	-	327.53
240.0	-	-	-	278.9	334.68	697.25	2789	-	353.14
250.0	194.07	485.18	1940.7	289.2	347.04	723	2892	-	-
260.0	-	-	-	-	-	-	-	-	380.31
300.0	212.02	530.05	2120.2	-	-	-	-	-	-
350.0	229.67	574.18	2296.7	-	-	-	-	-	-
400.0	247.04	617.6	2470.4	-	-	-	-	-	-
450.0	264.11	660.28	2641.1	-	-	-	-	-	-
500.0	280.90	702.25	2809	-	-	-	-	-	-
550.0	297.39	743.48	2973.9	-	-	-	-	-	-
600.0	313.59	783.98	3135.9	-	-	-	-	-	-

5.1.10. Analog outputs

The machine terminals equipped with an RTD/analog module have four general purpose 0...20 mA analog current outputs. All outputs are galvanically isolated from the supply and enclosure of the machine terminal and from each other.

For technical data of the analog outputs, refer to Table 5.2.1-7 on page 80.

	REM543/REM545 + RTD1
Analog outputs	RTD1_6_AO1
	RTD1_6_AO2
	RTD1_6_AO3
	RTD1_6_AO4

The parameters and events for the analog outputs are included in the event and parameter lists on the CD-ROM Technical Descriptions of Functions (see “Related documents” on page 8).

5.1.10.1. Selection of analog output range

The outputs can be set to two different current ranges with the `Output range` parameters in the menu `Configuration/RTD1/Output #`.

Parameter	Values	Default
Output range	0 = 0...20 mA 1 = 4...20 mA	0...20 mA

5.1.10.2. Attributes of an analog output for machine terminal configuration

The status (value) and the validity of the output can be issued for each analog output by the attributes `AO#` (REAL type) and `AO#IV` (BOOL type), where # denotes the number of the output. These attributes are available in the machine terminal configuration and can be used for different purposes.

Value (AO#)

The value written to `AO#` is transferred to a current signal at the output. The output response time is ≤ 85 ms, consisting of the software delay and the rise time of the analog output, counted from the moment when the value attribute is updated in the configuration program.

Invalidity (AO#IV)

The `AO#IV` attribute represents the invalidity status of the output. The attribute is set to FALSE when the value (`AO#`) is valid, i.e. an equal amount of current is flowing through the output, and to TRUE when the value is invalid, i.e. the current at the output is different from the value of `AO#`. When the `AO#IV` attribute is TRUE, this indicates one of two situations: either the current loop connected to the output is broken or the value attribute is written with a value outside the range defined by

the `Output range` parameter. The transition of the `AO#IV` state may also generate an event. Event generation is controlled by the `Event mask` parameter found in the menu `Configuration/RTD1`.

The output behaviour when the value attribute is outside the defined limits is as follows:

Output range	Value of AO#	Output current	Invalidity attribute AO#IV
0...20 mA	>20	20 mA	TRUE
	0...20	0...20 mA	FALSE
	<0	0 mA	TRUE
4...20 mA	>20	20 mA	TRUE
	4...20	4...20 mA	FALSE
	<4	0 mA	TRUE

Note that the output is also forced to 0 mA on the 4...20 mA range when the value is below the low limit. This behavior can be used to indicate a fault to the receiver.

5.1.10.3.

Analog output configuration example

The analog outputs are supported in the Relay Configuration Tool by the `MEAO1...MEAO4` analog output function blocks. As an example, to display the measured value of neutral current on an analog gauge, the neutral current measurement block `MECU1A` is connected to `MEAO1`, which in turn is connected to the `RTD1_6_AO1` global variable. The output invalid signal `RTD1_6_AO1IV` is connected to the `MMIALAR1` function block to achieve a visual indication of a fault. The `MEAO_` function blocks contain the parameters necessary for scaling the measured value to fit the selected output range. The `MEAO_` function blocks also limit the output change frequency to achieve a tolerable system load.

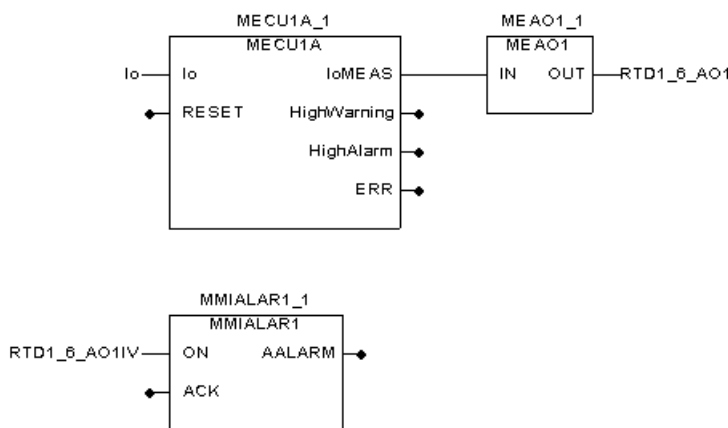

A060254

Fig. 5.1.10.3.-1 Analog output configuration example

5.1.11.**Trip circuit supervision**

The trip circuit supervision inputs TCS1 and TCS2 in the REM 54_ consist of two functional units:

- a constant-current generator including the necessary hardware elements
- a software-based functional unit for signalling

The functional units are based on the CMTCS1 and CMTCS2 function blocks included in the condition monitoring category.

The supervision of the trip circuit is based on the constant-current injection principle. If the resistance of the trip circuit exceeds a certain limit, for instance due to bad contact or oxidation, or if the contact has welded, the voltage over the supervised contact falls below 20 V AC/DC (15...20V) and the supervision function of the trip circuit is activated. If the fault persists, the trip circuit supervision alarm signal ALARM is obtained once the preset delay time of the function block CMTCS_ elapses.

The input/output circuits are galvanically isolated from each other. The constant-current generator forces a 1.5 mA measuring current through the circuit-breaker trip circuit. The constant current generator is connected over the trip contact of the machine terminal circuit. The current generator for the TCS1 is connected to the terminals X4.1/12-13 and the current generator for the TCS2 to the terminals X4.1/17-18 of the machine terminal.

Under no-fault conditions, the voltage over the contact of the constant current generator must be above 20 V AC/DC.

Mathematically, operating condition can be expressed as:

$$U_c - (R_{h_{ext}} + R_{h_{int}} + R_s) \cdot I_c \geq 20V_{ACDC}$$

where

- U_c = operating voltage over the supervised trip circuit
- I_c = measuring current through the trip circuit, approximately 1.5 mA (0.99... 1.72 mA)
- $R_{h_{ext}}$ = external shunt resistor value
- $R_{h_{int}}$ = internal shunt resistor value, 1 k Ω
- R_s = trip coil resistance value

The resistor $R_{h_{ext}}$ must be so calculated that the trip circuit supervision current through the resistor is low enough not to influence the trip coil of the circuit breaker. On the other hand, the voltage drop over the resistor $R_{h_{ext}}$ must be low enough not to jeopardize the operating condition presented in the formula above.

The following values are recommended for the resistor $R_{h_{ext}}$ in refer to chapter 5.1.11.-1 below:

Operating voltage U_c	Shunt resistor $R_{h_{ext}}$
48 V DC	1.2 k Ω , 5 W
60 V DC	5.6 k Ω , 5 W
110 V DC	22 k Ω , 5 W
220 V DC	33 k Ω , 5 W

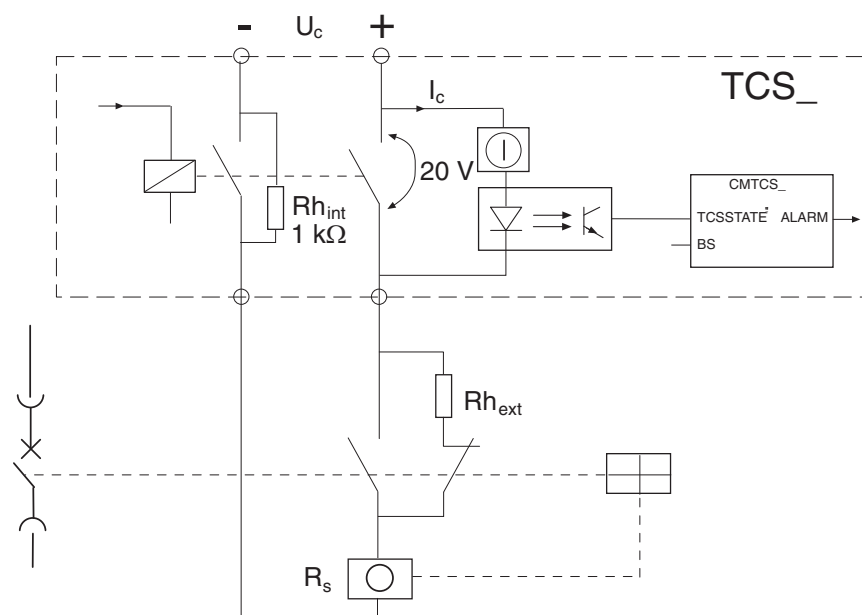

A060255

Fig. 5.1.11.-1 Operating principle of the trip circuit supervision (TCS) function

5.1.11.1.

Configuring the trip circuit supervision CMTCS_

The Relay Configuration Tool can be used to connect the trip circuit supervision input status signals to the function blocks CMTCS1 and CMTCS2. The configuration of the blocking signal is user-specific and can only be defined in the machine terminal configuration. The trip circuit supervision inputs in the machine terminal configuration are as follows:

TCS1 and TCS2 inputs in REM 543 and REM 545:

Trip Circuit Supervision 1 input	PS1_4_TCS1
Trip Circuit Supervision 2 input	PS1_4_TCS2

For more information about the trip circuit supervision functions CMTCS1 and CMTCS2, refer to the Technical Descriptions of Functions CD-ROM.

5.1.12. Self-supervision (IRF)

The machine terminal is provided with an extensive self-supervision system. The self-supervision system handles run-time fault situations and informs the user of faults via the HMI and LON/SPA communication. See also Table 5.2.1-12 on page 83.

5.1.12.1. Fault indication

The self-supervision signal output operates on the closed circuit principle. Under normal conditions the output relay is energized and the contact gap 3-5 is closed. Should the auxiliary power supply fail or an internal fault be detected, the contact gap 3-5 is opened.

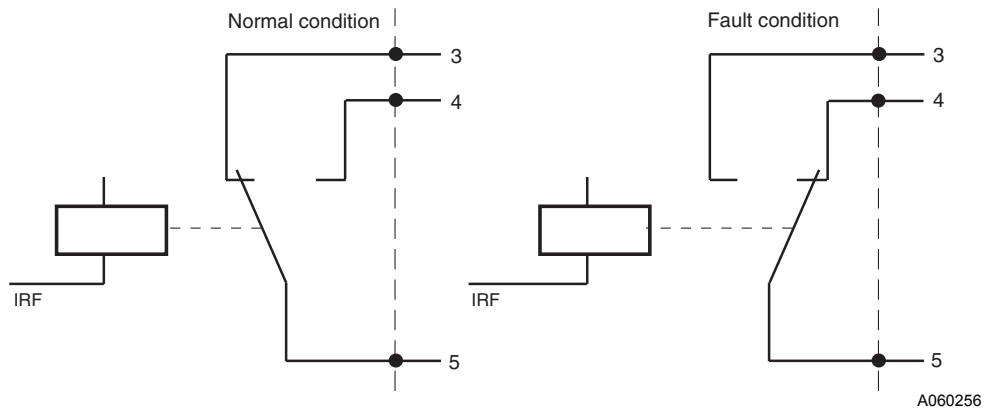

Fig. 5.1.12.1.-1 Self-supervision output (IRF)

When a fault has been detected, the green Ready indicator starts blinking, a fault indication text is displayed on the HMI and an event, E57, is generated over the serial communication. The fault indication text on the HMI consists of two rows as shown below:



Fig. 5.1.12.1.-2 IRF indication text

Fault indication has the highest priority on the HMI and cannot be overrun by any other HMI indication. The fault indication text is displayed until cleared by pressing the C button for 2 seconds. Then the green READY indicator still remains blinking.

If the internal fault disappears the fault indication text remains on the display unless it has been cleared, but the green READY indicator stops blinking. In addition, an event E56 is generated over the serial communication.

5.1.12.2. Fault codes

When an internal fault appears in REM 54_, the self-supervision system generates an IRF code that indicates the type of the fault. The fault code can be read from the machine terminal main menu Status/General/IRF code. The code indicates the first internal fault detected by the self-supervision system.



Do not reset the machine terminal before reading the IRF code. The code should be supplied when overhaul is ordered.

The following table gives an overview of the fault origin.

Codes	Explanation
0 ->	Faults related to a module of the machine terminal, e.g. the MIMIC card, BIO card or RTD/analog module
3000 ->	Faults related to the parameter database
6000 ->	Faults related to the analog measurement inputs
7000 ->	Software faults
15000 ->	Faults related to testing

5.1.13. Serial communication

The machine terminal has three serial communication ports, one on the front panel and two on the rear panel.

5.1.13.1. Serial communication port assignment

The bus communication protocol for the rear interface RS-232 (connector X3.2) is selected via the `Protocol 2` setting parameter and the bus communication protocol for the rear interface RS-485 (connector X3.3) is selected via the `Protocol 3` setting parameter. These parameters can be modified by using the local menu (`Communication/General`) or by using the Relay Setting Tool.

The following table shows supported parallel communication protocols on the front and the rear connectors of the REM 54_ machine terminals.

Connectors/Communication parameters		
X3.2/Protocol 2	X3.3/Protocol 3	Front connector
SPA	LON	SPA
-	SPA	SPA
Modbus	-	SPA
Modbus	SPA	-
IEC 61850	LON (SMS)	SPA
IEC 61850	SPA (SMS)	-
IEC 61850	-	SPA
Profibus	LON (SMS)	SPA
Profibus	SPA (SMS)	-
Profibus	-	SPA

5.1.13.2. SPA/Modbus communication on the rear connector X3.2

The 9-pin D-type subminiature male connector (RS-232 connection) on the rear panel connects the machine terminal to the distribution automation system via the SPA bus or the Modbus. The RER 123 fibre-optic Bus Connection Module is used

for connecting the machine terminal to the fibre-optic communication bus for SPA protocol. The interface between the machine terminal and a RS-485 communication bus can be made through the RER 133 Bus Connection Module.

5.1.13.3. IEC 61850 communication by using SPA-ZC 400 on the rear connector X3.2

The 9-pin D-type subminiature male connector (RS-232 connection) on the rear panel connects the machine terminal to the distribution automation system via the IEC 61850 protocol. In the IEC 61850 mode, the SPA-ZC 400 Bus Connection Module is needed.

In the IEC 61850 mode, the baud rate for relay port X3.2 is set to 38400. Furthermore, the mode includes a limited IEC 61850 GOOSE message support when available in SPA-ZC 400.

5.1.13.4. Profibus-DPV1 communication by using SPA-ZC 302 on the rear connector X3.2

The 9-pin D-type subminiature male connector (RS-232 connection) on the rear panel connects the machine terminal to the distribution automation system via the Profibus protocol. The interface between the machine terminal and Profibus can be made through the SPA-ZC 302 Gateway.

In the Profibus mode, the baud rate for relay port X3.2 is set to 38400. The SPA-ZC 302 Gateway should be set to the same baud rate. If the SPA-ZC 302 Gateway is connected to multiple terminals, the “Protocol 2” parameter should be set to SPA mode and the SPA baud rate for port X3.2 to 19200.

5.1.13.5. LON/SPA bus communication on the rear connector X3.3

The 9-pin D-type subminiature female connector (RS-485 connection) on the rear panel connects the machine terminal to the distribution automation system via the SPA bus or the LON bus. The fibre-optic interface module type RER 103 is used for connecting the machine terminal to the fibre-optic communication bus. The module RER 103 supports both SPA bus and LON bus communication.

The other communication parameters for the rear RS-485 interface are set also via the `Communication` menu.

5.1.13.6. Front panel optical RS-232 connection for a PC

The optical connector on the front panel isolates the PC galvanically from the machine terminal. The front connector for the PC is standardized for ABB relay products and requires a specific opto-cable (ABB art. No 1MKC950001-2). The cable is connected to the serial RS-232 port of the PC.

The front panel is intended for the connection of a PC when configuring the machine terminal with the CAP 50_ and SMS 510 tools. The front connector uses the SPA bus protocol.

5.1.13.7.

Communication parameters

The communication parameters for the SPA, Modbus and LON protocols are set in the `Communication` menu of the terminal and activated by storing the changes and resetting the device. These parameters cannot be changed with the Relay Setting Tool.

The SPA bus protocol uses an asynchronous serial communication protocol (1 start bit, 7 data bits + even parity, 1 stop bit) with adjustable data transfer rate (Baud rate, default 9.6 kbps) of the communication parameters and SPA address (slave number).

The SPA communication parameters are the same for all SPA communication via the optical front connector, the rear RS-485 and RS-232 connectors. The SPA address is the same also for transparent SPA communication on the LON protocol.

Parameter	Value	Default value	Explanation
SPA address	0...999	1	Slave number for communication
Baud rate	4800; 9600; 19200 bps	9600	Data transfer rate for communication
Rear connection	Connect		Activate rear SPA connection ^a

- a. This functionality is valid only in machine terminal revisions of releases prior to Release 2.0. The parameter is accessible only via serial communication. SPA communication on the front connector inhibits the rear X3.3 SPA communication and the transparent SPA communication on the LON protocol and remains inhibited for one minute after the SPA communication has stopped. It is possible to release this blocking situation by writing the value 1 to the V202 variable.

Adjustable LON serial communication parameters are Subnet number, Node number and Bit rate.

Parameter	Value	Default value	Explanation
Subnet number	1...255	1	LON subnet number
Node number	1...127	1	LON node number
Bit rate	78.1; 1250 kbps	1250	LON communication speed

The bit rate 78.1 kbps on the LON protocol is used for the FTT-10 serial communication network using the RER 115 module connected to the X3.3 connector. The bit rate 1250 kbps on the LON protocol is used for the optical serial communication network using the RER 103 module connected to the X3.3 connector.

The Modbus protocol has two serial transmission modes: ASCII and RTU. These modes define the bit contents of the message fields transmitted in the network. Adjustable Modbus serial communication parameters are shown in the table below.

Parameter	Value	Default value	Explanation
Unit Address	1...247	1	Address of the unit in the Modbus network
CRC Order	Low/High; High/Low	Low/High	The order of CRC bytes in the protocol frame (not used in ASCII mode)
Modbus Mode	ASCII; RTU	RTU	ASCII or RTU mode
Baud rate	300; 1200; 2400; 4800;9600;19200 bps	9600	Communication speed of the Modbus protocol
No of stop bits	1...2	1	Number of stop bits
Next char. TO	0...65535 ms	0	Next character time-out
End of frame TO	2...65535 ms	10	End of frame time-out
Parity	NONE; ODD; EVEN	EVEN	Parity setting
No of data bits	5,6,7,8	8	Number of data bits

The SPA address and the Subnet/Node number on the LON are used for identifying the device from the protocol's point of view and they are independent of each other.

For more information, see Table 5.2.1-11 on page 82.

5.1.13.8.

Parallel communication support

When SPA is used, the rear side communication is not stopped when the front connector is "active". This enables e.g. uploading of the disturbance records without affecting the communication to the upper level.

Moreover, if LON is selected as a communication protocol and the front connector is "active", transparent SPA write commands are not inhibited via the LON bus.¹

1. Parallel communication is restricted prior to Release 2.0, refer to section "Release 2.0" on page 95.

5.1.13.9. System structure

The system very often resembles the system in the figure below. Generator or motor feeders are protected and controlled with REM 54_ machine terminals. Some protection, control or alarm functions are implemented by using REF 54_ feeder terminals, SPACOM units or other SPA bus devices (devices connected to the system via the SPA bus). MicroSCADA is used for remote control.

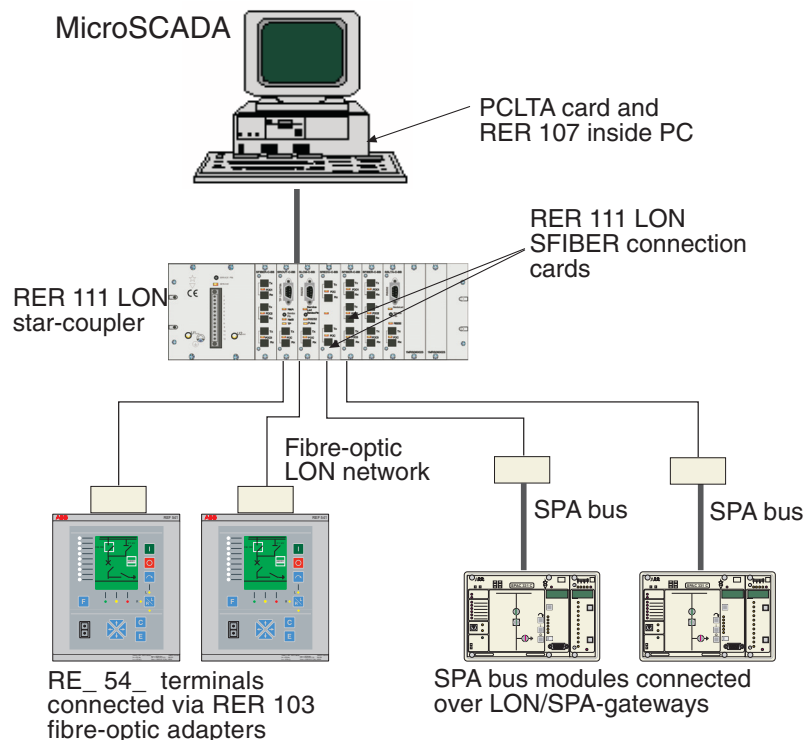

A050742

Fig. 5.1.13.9.-1 Example of a LON-based substation automation system

In the system described in the figure above, communication is usually arranged as shown in the table below.

Data type	REM <-> MicroSCADA	REM and LSG devices to each other
Events and alarms	sliding window protocol	-
Control commands	transparent SPA bus messages	-
Status of breakers and isolators	sliding window protocol	network variables
Analog measurement values	sliding window protocol	-
Other DI, AI data	sliding window protocol	network variables
Other DO, AO data	transparent SPA bus messages	network variables
Parameter data	transparent SPA bus messages	-
SPA file transfer data (e.g. the disturbance records)	transparent SPA bus messages	-

Technical Reference Manual, General

Other supported system configurations are represented in the following figures. A LON bus and a parallel SMS bus connected as a SPA loop using the interface module RER 123 on connector X3.2, allows to implement the redundant SMS workstation.

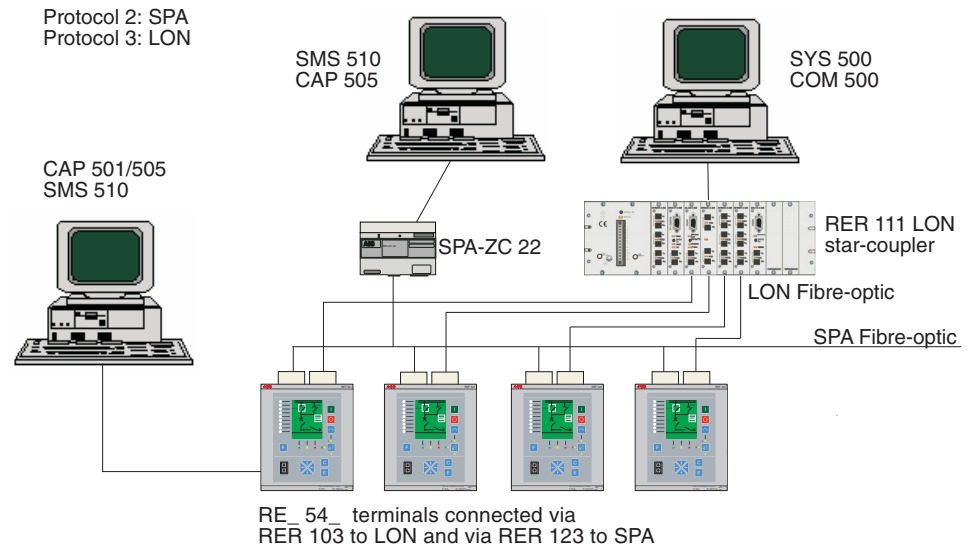

A060267

Fig. 5.1.13.9.-2 LON- and SPA-based substation automation system

The machine terminals are connected to the Modbus master device using the RER 133 Bus Connection Module on connector X3.2.

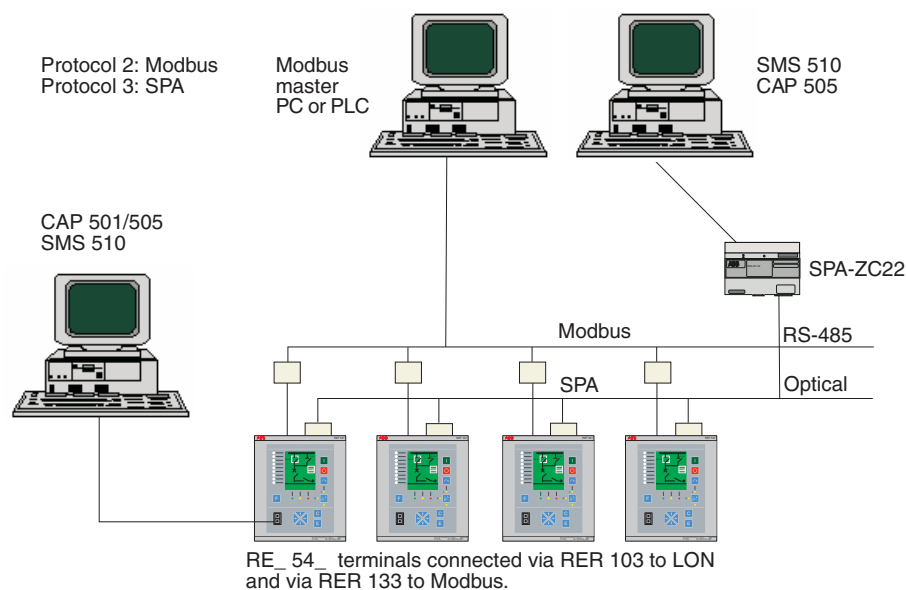

A060525

Fig. 5.1.13.9.-3 Modbus- and SPA-based substation automation system

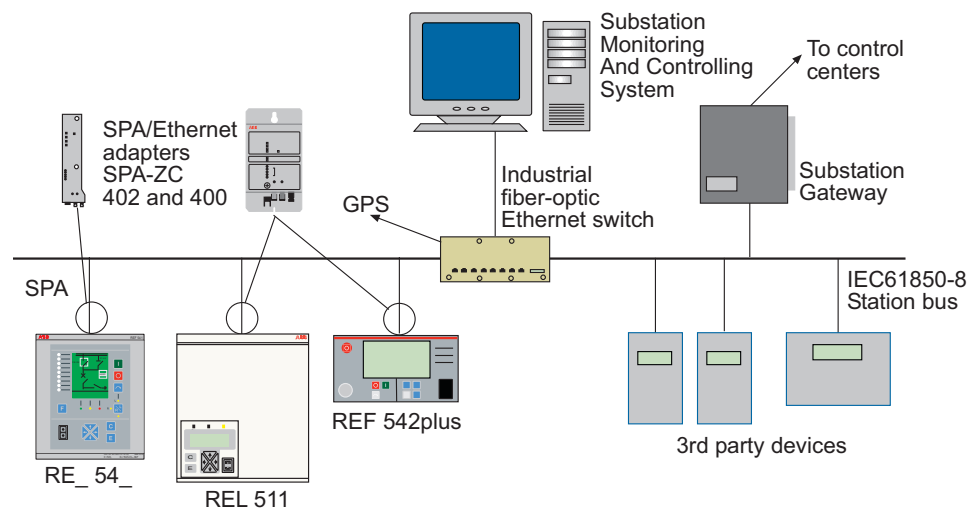

Fig. 5.1.13.9.-4 IEC61850-based substation automation system

5.1.13.10.

LON inputs and outputs via a LON bus

The machine terminal offers up to 32 freely programmable LON inputs and outputs on the LON bus. The inputs and outputs use the LONMark Standard network variable (NV type 83 = SNVT_state) for sending and receiving process data. The LON inputs and outputs are accessible in the machine terminal configuration and can be freely used for different types of data transfer between the machine terminals and other devices that are able to communicate using the network variable of type SNVT_state.

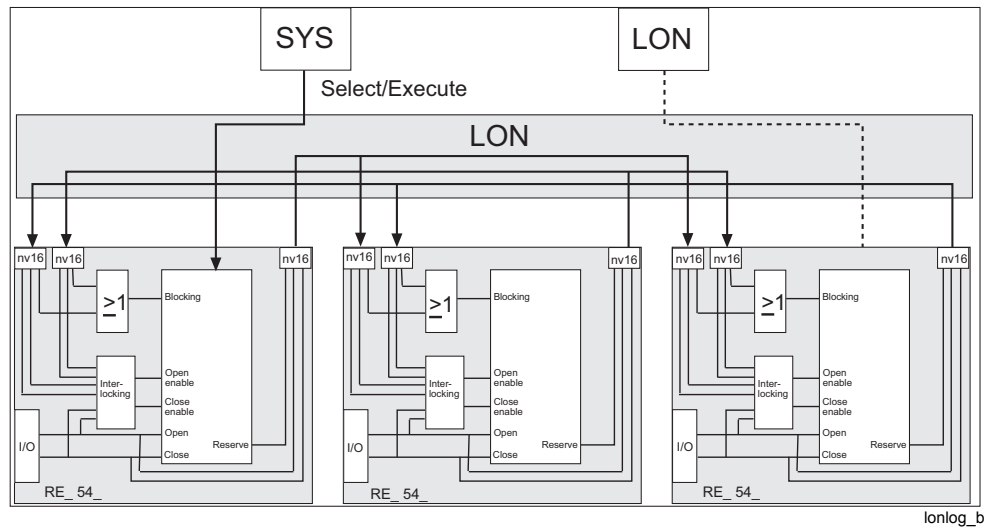

Fig. 5.1.13.10.-1 Principle of connecting LON inputs and outputs to logic functions of the machine terminal

The SNVT_state can be used to communicate the state of a set of 1 to 16 Boolean values. Each bit indicates the state of the Boolean value with, for example, the following interpretations:

0	1
off	on
inactive	active
disabled	enabled
low	high
false	true
normal	alarm

The value field shows the current value of the digital inputs or outputs at the time of reporting, or the latest value reported from the concerned device.

The SNVT_state can be used to transfer the state of 1 to 16 digital inputs, or to set the state of 1 to 16 output bits or digital set-points.

5.1.14. Display panel (HMI)

The machine terminal is provided with either a fixed display or an external display module. The external display module requires a separate voltage supply from a common source with the main unit (refer to section “Auxiliary voltage” on page 35). For more information about the rated input voltages, refer to Table 5.2.1-2 on page 79. A special cable (1MRS120511.002) delivered with the machine terminal is needed for communication between the terminal and the external display panel.

- graphical LCD display, with the resolution 128 x 160 pixels, consisting of 19 rows divided into two windows
- main window (17 rows) providing detailed information on MIMIC, objects, events, measurements, control alarms and parameters of the terminal
- assisting window (2 rows) for terminal-dependent protection indications and alarms, and for general help messages
- three push-buttons for object control
- eight freely programmable alarm LEDs with different colours and modes according to the configuration (off, green, yellow, red, steady, blinking)
- LED indicator for control test and interlocking
- three protection LED indicators
- HMI push-button section with four arrow buttons and buttons for clear [C] and enter [E]
- optically isolated serial communication port
- backlight and contrast control
- freely programmable button [F]
- button for remote/local control (Control position button [R\L])

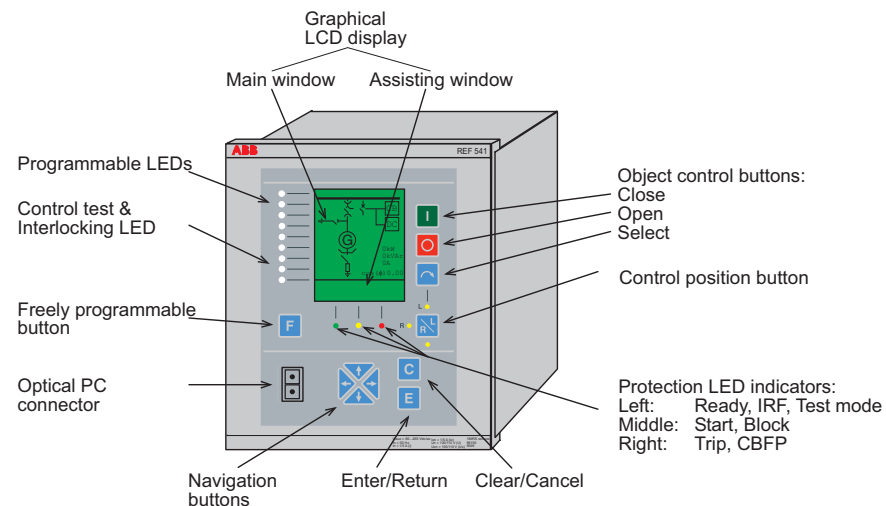

A060270

Fig. 5.1.14.-1 Front view of the REM 54_ machine terminal

The HMI has two main levels, the user level and the technical level. The user level is for everyday measurements and monitoring whereas the technical level is intended for advanced machine terminal programming.

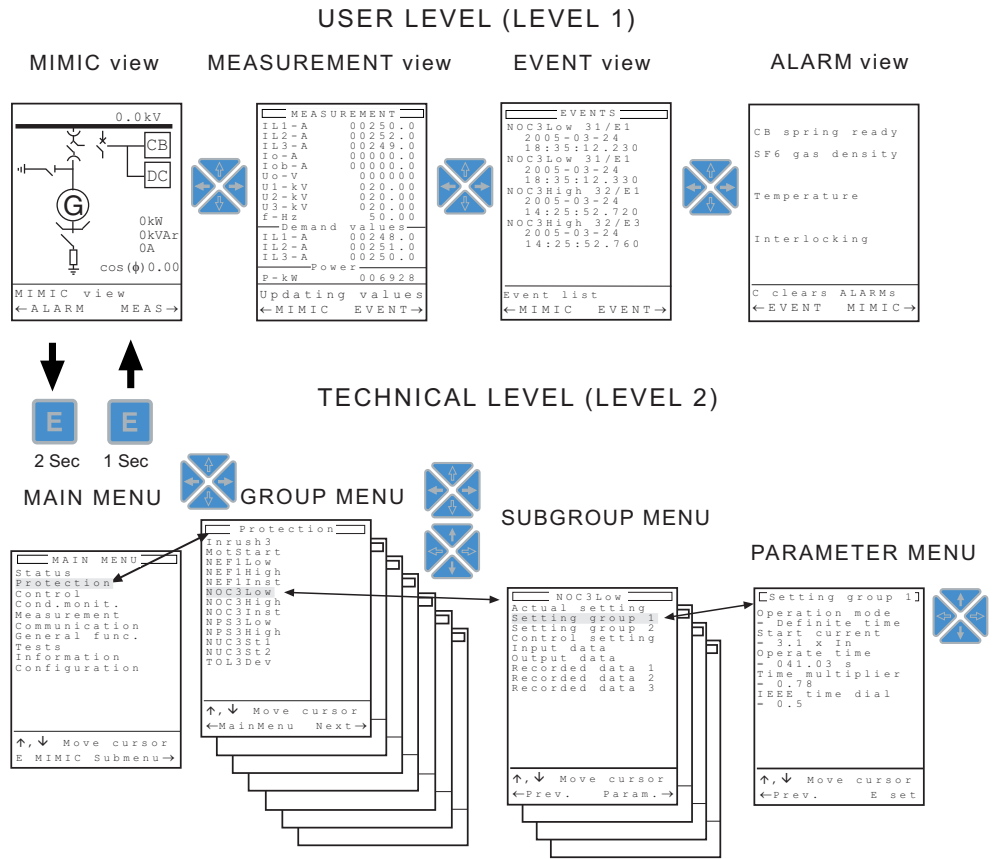

Fig. 5.1.14.-2 Menu level structure

For more detailed information about the HMI, please refer to the Operator’s Manual.

5.1.15.

Alarm LED indicators

The REM 54_ machine terminal offers eight alarm LED indicators to be configured with the Relay Mimic Editor. The LED colours are green, yellow or red, and their use can be freely defined (for defining the ON and OFF state texts, refer to section “MIMIC configuration” on page 31). Three basic operation modes are supported:

- non-latched light
- latched-steady light
- latched blinking light

Alarms can be acknowledged remotely, locally or by using logic.

The alarm channels include time tagging for detected alarms. The time tagging principle used depends on the operation mode.

The alarm channels are seen as function blocks in the machine terminal configuration:

Alarm channel	Function block
Alarm channel 1	MMIALARM1
Alarm channel 2	MMIALARM2
Alarm channel 3	MMIALARM3
Alarm channel 4	MMIALARM4
Alarm channel 5	MMIALARM5
Alarm channel 6	MMIALARM6
Alarm channel 7	MMIALARM7
Alarm channel 8	MMIALARM8

5.1.15.1. Non-latched alarm

In a non-latched mode, the ON signal switches between ON and OFF state texts and the corresponding LED colours. Alarm acknowledgement (ACK) clears the last time stamp line of the alarm view, but leaves the corresponding alarm LED state unchanged. An event is generated on the rising and falling edge of the ON signal and by acknowledgement.

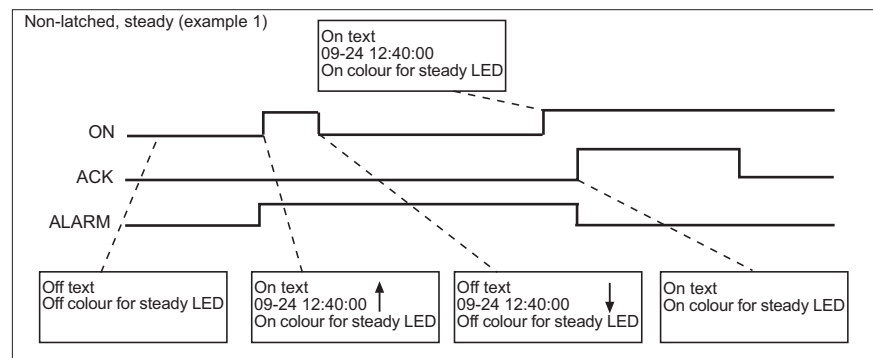

alarind4_b

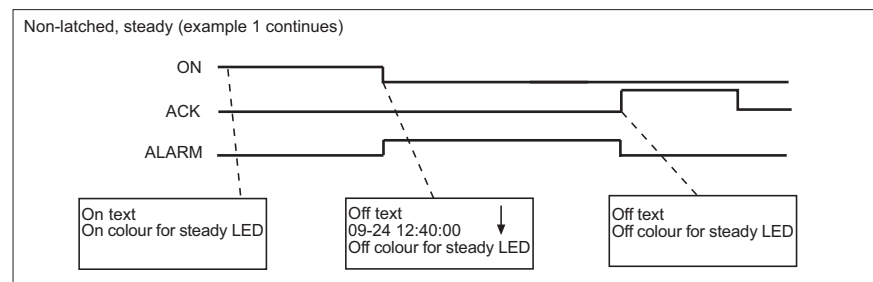

alarind5_b

Fig. 5.1.15.1.-1 Example of a non-latched alarm

5.1.15.2. Latched alarm, steady LED

Latched, steady alarms can be acknowledged only when the ON signal is inactive. The time stamp of the first alarm is recorded. Successful acknowledgement clears the time stamp line of the alarm view and the corresponding alarm LED. An event is generated on the rising and falling edge of the ON signal and by acknowledgement.

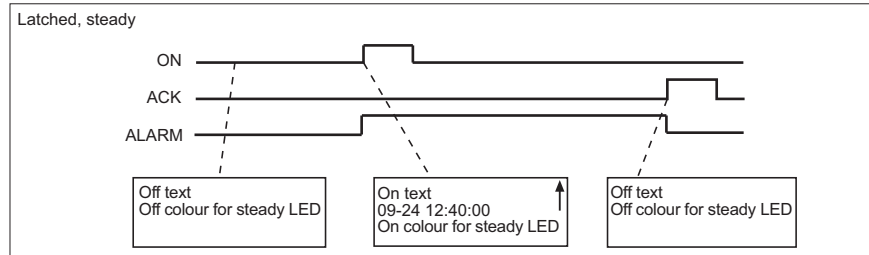

alarind3_b

Fig. 5.1.15.2.-1 Example of a latched alarm with steady LED

5.1.15.3. Latched alarm, blinking LEDs

Latched, blinking alarms can be acknowledged after the rising edge of the ON signal. The time stamp of the first alarm is recorded. If the ON signal is inactive, acknowledgement clears the time stamp line of the alarm view and the corresponding alarm LED. However, if the ON signal is active during acknowledgement, the alarm LED mode turns stable and the time stamp is cleared. Later, when the ON signal is deactivated, the alarm LED colour will automatically change to OFF colour. An event is generated on the rising and falling edge of the ON signal and by acknowledgement. The visual indication, including resetting, of this alarm mode complies with the ISA-A standard.

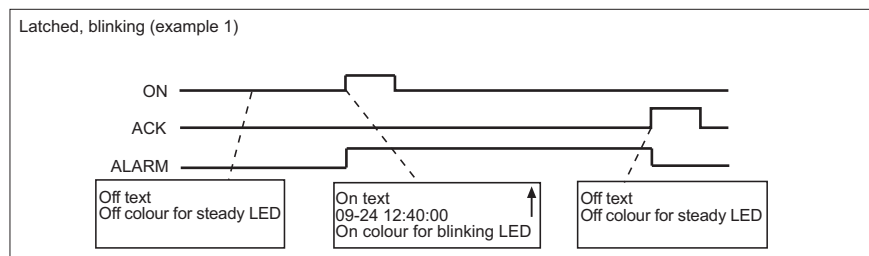

alarind2_b

Fig. 5.1.15.3.-1 Example 1 of a latched alarm with blinking LEDs

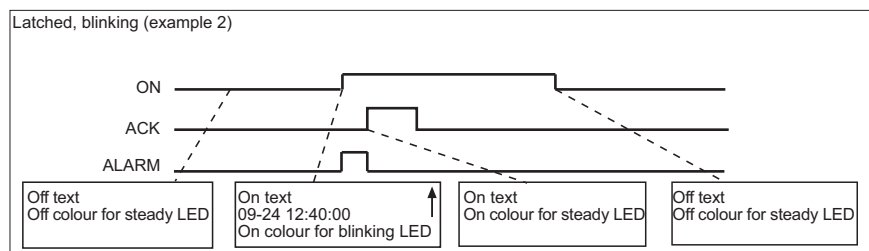

alarind1_b

Fig. 5.1.15.3.-2 Example 2 of a latched alarm with blinking LEDs

5.1.15.4.**Interlocking**

The interlocking LED text can be defined in the same manner as for the other alarm channels. The colour of the interlocking LED is yellow and cannot be changed. The normal LED state is inactive (no light). Furthermore, the interlocking LED has two special modes. The first mode, recognized by a steady yellow light, indicates that control operation has been interlocked. The second mode, recognized by a blinking red light, indicates that the interlocking is in bypass mode (control test mode).

General control test mode

The system provides a general interlocking bypass mode (Main menu/Control/Interl bypass) that overrides all interlocking signals. Activation of the interlocking bypass mode activates the interlocking enable signals of all control objects. Thus, all local control actions are possible and the enable signals (OPENENA, CLOSEENA) of controllable objects are not checked while the objects are commanded. As long as the mode is active, the interlocking LED on the HMI is blinking red. Additionally, the assisting window of the display will indicate the special condition.

5.2. Design description

5.2.1. Technical data

Table 5.2.1-1 Energizing inputs

Rated frequency		50.0/60.0 Hz	
Current inputs	rated current	0.2 A/1 A/5 A	
	Thermal withstand capability	continuously	1.5 A/4 A/20 A
		for 1 s	20 A/100 A/500 A
	dynamic current withstand, half-wave value	50 A/250 A/1250 A	
	input impedance	<750mΩ/<100mΩ/<20 mΩ	
Voltage inputs	rated voltage	100 V/110 V/115 V/120 V (parameterization)	
	voltage withstand, continuous	2 x U _n (240 V)	
	burden at rated voltage	<0.5 VA	
Sensor inputs	AC voltage range	9.4 V RMS	
	DC voltage range	±13.3 peak	
	input impedance	>4.7 MΩ	
	input capacitance	<1 nF	

Table 5.2.1-2 Auxiliary power supplies

Type	PS1/240V	External display module	PS1/48V
Input voltage, AC	110/120/220/240 V		-
Input voltage, DC	110/125/220 V		24/48/60 V
Operating range	AC 85...110%, DC 80...120% of rated value		DC 80...120% of rated value
Burden	<50 W		
Ripple in DC auxiliary voltage	max. 12% of the DC value		
Interruption time in auxiliary DC voltage without resetting	<40 ms, 110 V DC and <100 ms, 200 V DC		
Internal overtemperature indication	+78°C (+75...+83°C)		

Table 5.2.1-3 Digital inputs

Power supply version	PS1/240 V (High)	PS1/240 V (Medium)	PS1/48 V (Low)
Input voltage, DC	220 V	110/125/220 V	24/48/60/110/125/220 V
Operating range, DC	155...265 V	80...265 V	18...265 V
Current drain	~2...25 mA		
Power consumption/input	<0.8 W		
Pulse counting (specific digital inputs), frequency range	0...100 Hz		

Technical Reference Manual, General

Table 5.2.1-4 RTD/analog inputs

Supported RTD sensors	100 Ω Platinum	TCR 0.00385 (DIN 43760)
	250 Ω Platinum	TCR 0.00385
	1000 Ω Platinum	TCR 0.00385
	100 Ω Nickel	TCR 0.00618 (DIN 43760)
	120 Ω Nickel	TCR 0.00618
	250 Ω Nickel	TCR 0.00618
	1000 Ω Nickel	TCR 0.00618
	10 Ω Copper	TCR 0.00427
	120 Ω Nickel	TCR 0.00672 (MIL-T-24388C)
Max lead resistance (three-wire measurement)	200 Ω per lead	
Accuracy	$\pm 0.5\%$ of full scale $\pm 1.0\%$ of full scale for 10 Ω Copper RTD	
Isolation	2 kV (inputs to outputs and inputs to protective earth)	
Sampling frequency	5 Hz	
Response time	\leq Filter time + 30 ms (430 ms...5.03 s)	
RTD / Resistance sensing current	max 4.2 mA RMS 6.2 mA RMS for 10 Ω Copper	
Current input impedance	274 $\Omega \pm 0.1\%$	

Table 5.2.1-5 Signal outputs

Max system voltage	250 V AC/DC
Continuous carry	5 A
Make and carry for 0.5 s	10 A
Make and carry for 3 s	8 A
Breaking capacity when control circuit time-constant L/R <40 ms, at 48/110/220 V DC	1 A/0.25 A/0.15 A

Table 5.2.1-6 Power outputs

Max system voltage	250 V AC/DC	
Continuous carry	5 A	
Make and carry for 0.5 s	30 A	
Make and carry for 3 s	15 A	
Breaking capacity when control circuit time constant L/R <40 ms, at 48/110/220 V DC ^a	5 A/3 A/1 A	
Minimum contact load	100 mA, 24 V AC/DC (2.4 VA)	
TCS (Trip Circuit Supervision)	Control voltage range	20...265 V AC/DC
	Current drain through the supervision circuit	approx. 1.5 mA (0.99...1.72 mA)
	Minimum voltage (threshold) over a contact	20 V AC/DC (15...20 V)

a. two contacts in series

Table 5.2.1-7 Analog outputs

Output range	0...20 mA
Accuracy	$\pm 0.5\%$ of full scale
Max load	600 Ω
Isolation	2 kV (output to output, output to inputs and output to protective earth)
Response time	≤ 85 ms

Table 5.2.1-8 Environmental conditions

Specified service temperature range		-10...+55°C
Transport and storage temperature range		-40...+70°C
Enclosure class	front side, flush-mounted	IP 54
	rear side, connection terminals	IP 20
Dry heat test		according to IEC 60068-2-2
Dry cold test		according to IEC 60068-2-1
Damp heat test, cyclic		according to IEC 60068-2-30, r.h. = 95%, T = 25°...55°C
Storage temperature tests		according to IEC 60068-2-48

Table 5.2.1-9 Standard tests

Insulation tests	Dielectric test IEC 60255-5	Test voltage	2 kV, 50 Hz, 1 min.
	Impulse voltage test IEC 60255-5	Test voltage	5 kV, unipolar impulses, waveform 1,2/50 μs, source energy 0.5 J
	Insulation resistance measurements IEC 60255-5	Insulation resistance	> 100 MΩ, 500 V DC
Mechanical tests	Vibration tests (sinusoidal)		IEC 60255-21-1, class I
	Shock and bump test		IEC 60255-21-2, class I
	Seismic tests		IEC 60255-21-3, class 2

Table 5.2.1-10 Electromagnetic compatibility tests

The EMC immunity test level fulfills the requirements listed below		
1 MHz burst disturbance test, class III, IEC 60255-22-1	common mode	2.5 kV
	differential mode	1.0 kV
Electrostatic discharge test, class III IEC 61000-4-2 and 60255-22-2	for contact discharge	6 kV
	for air discharge	8 kV
Radio frequency interference test	conducted, common mode IEC 61000-4-6	10 V (rms), f = 150 kHz...80 MHz
	radiated, amplitude-modulated IEC 61000-4-3	10 V/m (rms), f = 80...1000 MHz
	radiated, pulse-modulated ENV 50204	10 V/m, f = 900 MHz
	radiated, test with a portable transmitter IEC 60255-22-3, method C	f = 77.2 MHz, P = 6 W; f = 172.25 MHz, P = 5 W
Fast transient disturbance test IEC 60255-22-4 and IEC 61000-4-4	power supply	4 kV
	I/O ports	2 kV
Surge immunity test IEC 61000-4-5	power supply	4 kV, common mode 2 kV, differential mode
	I/O ports	2 kV, common mode 1 kV, differential mode
Power frequency (50 Hz) magnetic field IEC 61000-4-8	100 A/m	
Voltage dips and short interruptions IEC 61000-4-11	30%, 10 ms 60%, 100 ms 60%, 1000 ms >90%, 5000 ms	

Technical Reference Manual, General

Table 5.2.1-10 Electromagnetic compatibility tests (Continued)

Electromagnetic emission tests EN 55011 and EN 50081-2	conducted RF emission (mains terminal)	EN 55011, class A
	radiated RF emission	EN 55011, class A
CE approval	Complies with the EMC directive 89/336/EEC and the LV directive 73/23/EEC	

Table 5.2.1-11 Data communication

Rear interface, connector X3.1	not used, reserved for future purposes	
Rear interface, connector X3.2	RS-232 connection	
	RER 123 fibre-optic Bus Connection Module	
	protocol	SPA
	RER 133 RS-485 Bus Connection Module	
	protocol	Modbus
	SPA-ZC 302 Profibus-DPV1/SPA Gateway	
	protocol	Profibus-DPV1 ^a
	SPA-ZC 400 SPA/ Ethernet Adapter	
	protocol	IEC 61850 ^a
Rear interface, connector X3.3	RS-485 connection	
	RER 103 fibre-optic Bus Connection Module is needed for galvanic isolation	
	protocol	SPA, LON
Rear interface, connector X3.4	RJ45 connection	
	galvanically isolated RJ45 connection for an external display panel	
	protocol	CAN
	communication cable	1MRS 120511.001 (1 m) 1MRS 120511.002 (2 m) 1MRS 120511.003 (3 m)
Front panel	optical connection	
	protocol	SPA
	communication cable	1MKC950001-2
SPA protocol	baud rates	4,8/9,6/19,2 kbps
	start bits	1
	data bits	7
	parity	even
	stop bits	1
LON protocol	bit rates	78.0 kbps/1.2 Mbps
Modbus protocol	baud rates	0,3/ 1,2/ 2,4/ 4,8 and 9,6 kbps
	modbus modes	ASCII, RTU

- a. These functions are only supported in the latest patch releases of machine terminal Release 2.5 or later.

Technical Reference Manual, General

Table 5.2.1-12 General

Toolboxes	CAP 501 CAP 505 LNT 505	
Event recording	all events are recorded in higher level syntax: reason, time, date the last 100 events are recorded	
Data recording	records operate values	
Protection functions Control functions Condition monitoring functions Measurement functions Communication functions	see Technical Descriptions of Functions (1MRS 750889-MCD)	
Self-supervision	RAM circuits ROM circuits Parameter memory circuits CPU watchdog Power supply Digital I/O modules HMI module RTD/analog input module Internal communication bus A/D converters and analog multiplexers	
Mechanical dimensions	Width: 223.7 mm (1/2 of a 19" rack) Height, frame: 265.9 mm (6U) Height, box: 249.8 mm Depth: 235 mm For dimension drawings, refer to the Installation Manual (1MRS 750526-MUM)	
	External display module:	Width: 223.7 mm Height: 265.9 mm Depth: 74 mm
Weight of the unit	~8 kg	

5.2.2. Terminal diagram of REM 543

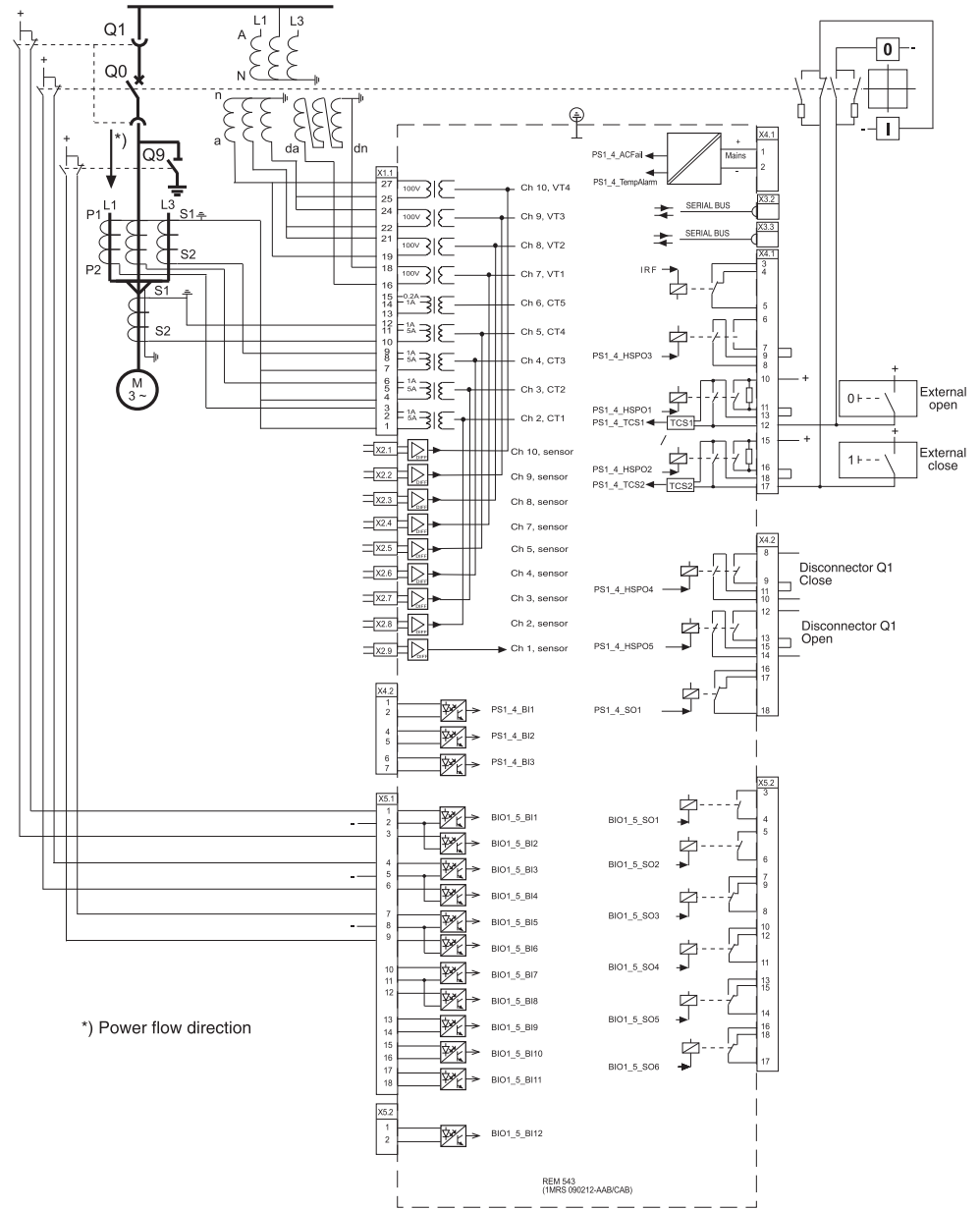

A060273

Fig. 5.2.2.-1 Terminal diagram of REM 543

5.2.3.

Terminal diagram of REM 545

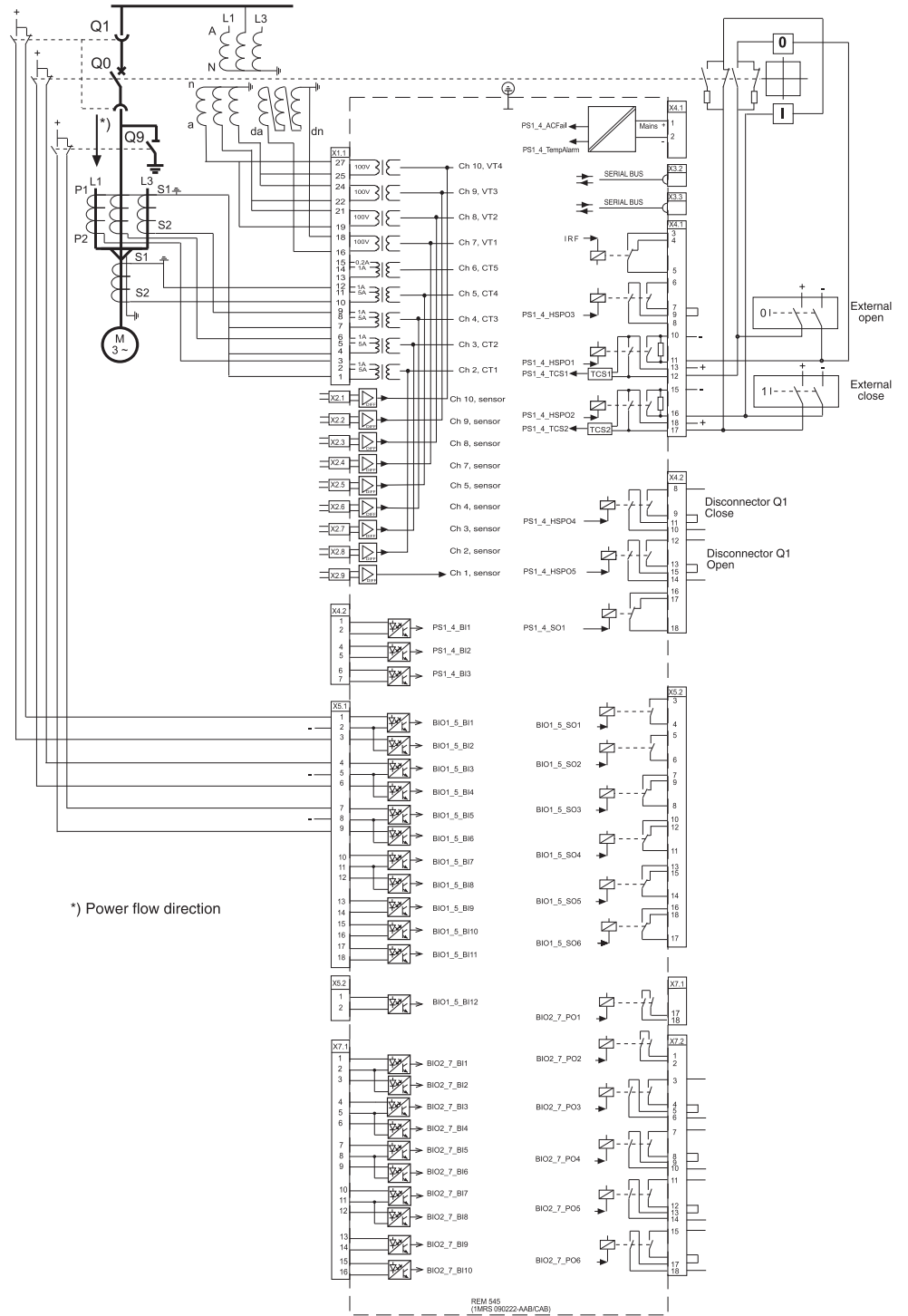
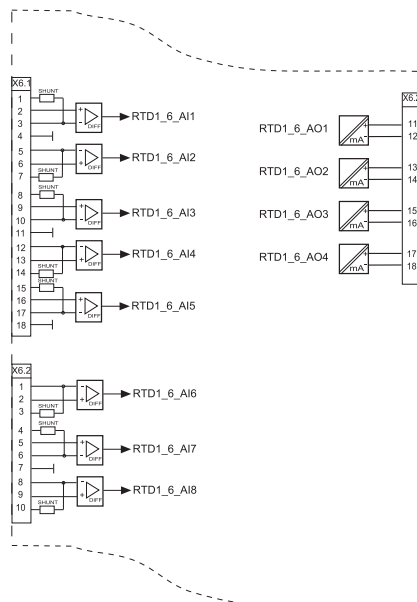

Fig. 5.2.3.-1 Terminal diagram of REM 545

A060274

5.2.4. Terminal diagram of the RTD/analog module

Terminal diagrams for the machine terminals provided with an RTD/analog module are similar to the diagrams presented in sections “Terminal diagram of REM 543” on page 84 and “Terminal diagram of REM 545” on page 85, except for the part illustrating the RTD/analog module (see below), which is added to the diagrams considering the slot numbers.



A050205

Fig. 5.2.4.-1 Terminal diagram of the RTD/analog module

5.2.5. Definition of power direction

When the overexcited generator (G) feeds the inductive load (motor M), the real and reactive power signs are as shown in the figure below. The connections in generator and motor terminals are identical (as in the terminal diagram of REM 543 on page 84). The power direction parameter (for example in function blocks UPOW_, OPOW_, MEPE7) is set to Reverse in the generator terminal and to Forward in the motor terminal.

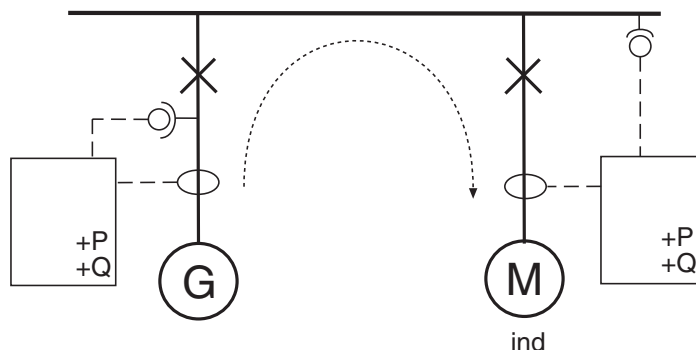

A060275

Fig. 5.2.5.-1 Definition of power direction in REM 54_

5.2.6. Terminal connections

All external circuits are connected to the terminal blocks on the rear panel. Terminal block X1.1 for the measuring transformers consists of fixed screw terminals fastened to the energizing input module. Each terminal is dimensioned for one max. 6 mm² or two max. 2.5 mm² wires.

ABB sensors (Rogowski coil or voltage divider) are connected to the connectors X2.1...X2.9. A special type of shielded twin BNC connector (type AMP 332225 or Amphenol 31-224) is used to improve reliability and protection against disturbances. The current and/or voltage sensor used must have a connector that is compatible with the machine terminal. If the machine terminal is ordered without sensor inputs, the sensor connectors X2.1...X2.9 are missing. Short-circuit connectors (1MRS120515) must be connected to unused sensor inputs.

The RS-232 serial interface on the rear panel (connector X3.2) is used to connect REM 54_ to the SPA, Modbus, Profibus or IEC 61850 bus.

The SPA bus is connected through the RER 123 fibre-optic bus connection module. The Modbus can be connected through a RER 133 Bus Connection Module. Profibus is available through the SPA-ZC 302 Gateway and IEC 61850 is available through the SPA-ZC 400 Ethernet Adapter. For further information, about the external interface units, refer to the Technical Description of the module concerned. (See "Related documents" on page 8.)

The RS-485 serial interface (connector X3.3) on the rear panel is used for connecting the machine terminal to the SPA bus or the LON bus. The SPA/LON bus is connected via the connection module RER 103 fitted to the 9-pin D-type subminiature female connector and screwed to the rear panel.

The connectors X4.1...X7.2 are 18-pin detachable multi-pole connector strips with screw terminals. The male part of the multi-pole connector strips is fastened to the printed circuit boards. The female parts, including accessories, are delivered together with the machine terminal. The female connector part can be secured with fixing accessories and screws. One max. 1.5 mm² wire or two max. 0.75 mm² wires can be connected to one screw terminal.

The digital inputs and outputs (contacts) of the machine terminal are connected to the multi-pole connectors X4.1...X7.2. The auxiliary power supply is connected to the terminals X4.1:1 (plus polarity) and X4.1:2 (minus polarity). When the RTD/ analog module is used, the inputs and outputs are connected to the terminals X6.1:1 and X6.1:2. The machine terminal self-supervision output IRF is linked to the terminals X4.1:3, X4.1:4 and X4.1:5.

Protective earth is connected to the screw marked with the earth symbol.

The connectors are designated according to the module slot in the REM 54_ machine terminal.

Table 5.2.6-1 REM 54_ terminal connections

Connector	Description
X1.1	connector for transformer inputs (current and voltage transformers) (module slot 1)
X2.1	connector for sensor input 9 (slot 2)
X2.2	connector for sensor input 8 (slot 2)
X2.3	connector for sensor input 7 (slot 2)
X2.4	connector for sensor input 6 (slot 2)
X2.5	connector for sensor input 5 (slot 2)
X2.6	connector for sensor input 4 (slot 2)
X2.7	connector for sensor input 3 (slot 2)
X2.8	connector for sensor input 2 (slot 2)
X2.9	connector for sensor input 1 (slot 2)
X3.1	not used, reserved for future purposes (slot 3)
X3.2	connector for RS-232 interface (slot 3)
X3.3	connector for RS-485 interface (slot 3)
X3.4	connector for the external display module (slot 2)
X4.1	upper connector for combined I/O and power supply module PS1 (slot 4)
X4.2	lower connector for combined I/O and power supply module PS1 (slot 4)
X5.1	upper connector for I/O module BIO1 (slot 5)
X5.2	lower connector for I/O module BIO1 (slot 5)
X6.1	upper connector for I/O module BIO1 (slot 6), REM 543 upper connector for RTD/analog module (slot 6), REM 543 or REM 545 with RTD/analog module
X6.2	lower connector for I/O module BIO1 (slot 6), REM 543 lower connector for RTD/analog module (slot 6), REM 543 or REM 545 with RTD/analog module
X7.1	upper connector for I/O module BIO2 (slot 7)
X7.2	lower connector for I/O module BIO2 (slot 7)

REM543B_212AABA/CABA

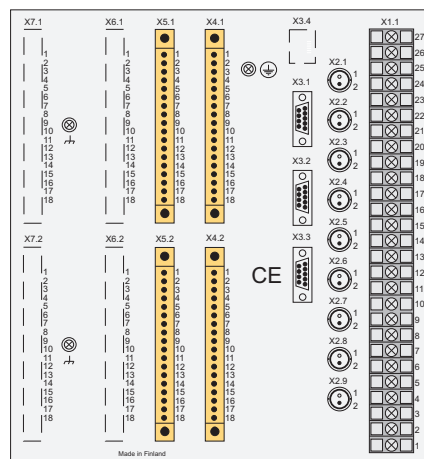

BIO1
PS1
CPU1
MIM, SIM,
Transfrm

REM543A_213AABA/CABA

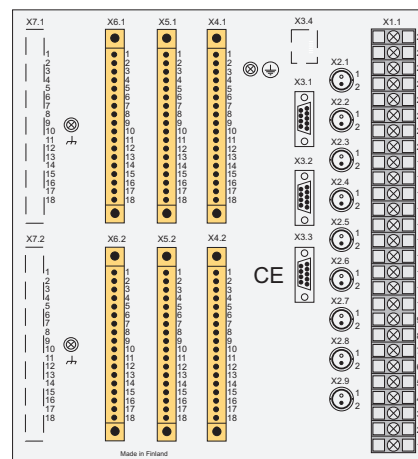

RTD1
BIO1
PS1
CPU1
MIM, SIM,
Transfrm

Fig. 5.2.6.-1 Rear views of REM 543 (right: with RTD/analog module)

A060276

REM545A_222AABA/CABA

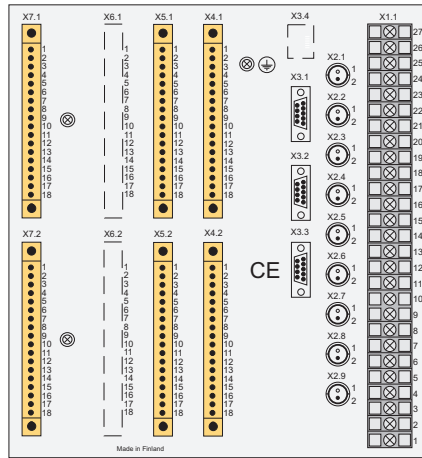

BIO2
BIO1
PS1
CPU1
MIM, SIM,
Transfrm

REM545A_223AABA/CABA

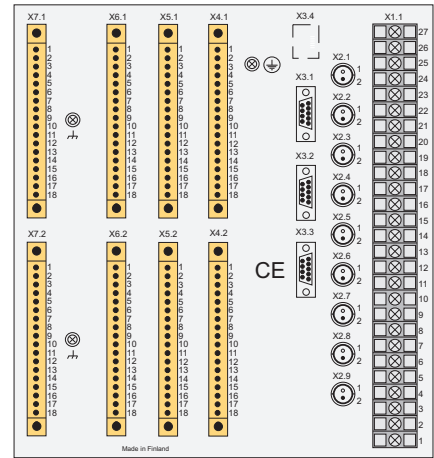

BIO2
RTD1
BIO1
PS1
CPU1
MIM, SIM,
Transfrm

A060277

Fig. 5.2.6.-2 Rear views of REM 545 (right: with RTD/analog module)

REM545A_223AABB

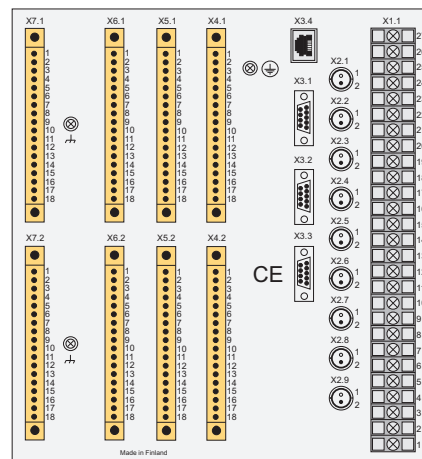

BIO2
RTD1
BIO1
PS1
CPU1
MIM, SIM,
Transfrm

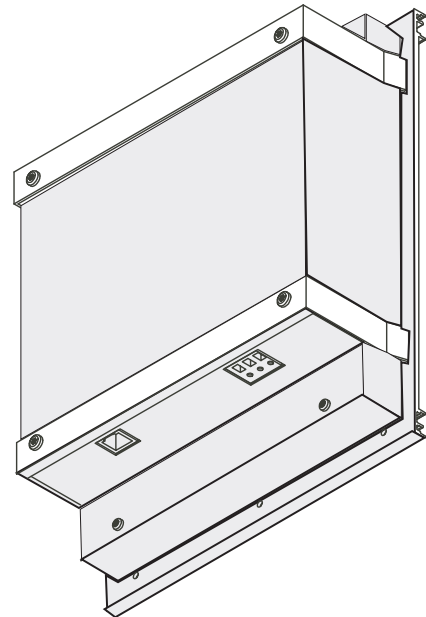

A060278
A060280

Fig. 5.2.6.-3 Rear view of REM 545 with an external display module (right: the external display module)

6. Service

When the machine terminal is used under the conditions specified in Section 5.2.1. Technical data, it is practically maintenance-free. The machine terminal electronics include no parts or components subject to abnormal physical or electrical wear under normal operating conditions.

If the terminal fails in operation or if the operating values considerably differ from those mentioned in the machine terminal specifications, the terminal should be overhauled. Only personnel authorized by the manufacturer is allowed to carry out repairs. Please contact the manufacturer or the nearest representative for further information about checking, overhaul and recalibration of the terminal.



To achieve the best possible operation accuracy, all parts of the machine terminal have been calibrated together. In the event of malfunction, please consult your supplier.

If the protection relay is sent to the manufacturer, it has to be carefully packed to prevent further damage to the device.

7. Ordering Information

7.1. Order number

The following is to be specified when ordering REM 54_ machine terminals:

- Order number (see Fig. 7.1.-1)
- Display language combination (e.g. English-German)
- Quantity of machine terminals

Each machine terminal has a specific order number that identifies the machine terminal type as well as the hardware and the software as described in refer to chapter 7.1.-1 below. The order number is labelled on the marking strip on the front panel of the machine terminal delivered, e.g. Order No: REM543CM212AAAA.

REM543CM212AAAA

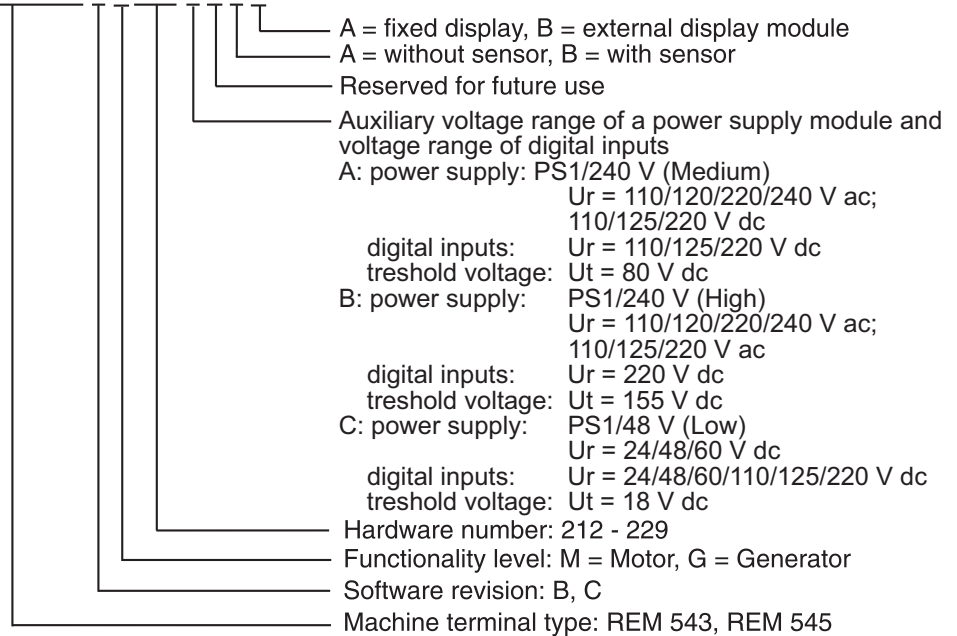

A060279

Fig. 7.1.-1 Order number of REM 54_

The functionality level determines the selection of function blocks available for the machine terminal. For more detailed information on the separate function blocks included in each selection, please consult your relay supplier.

The display language combination (see table below) is identified by a three-digit suffix in the software number labelled on the front panel of the machine terminal, e.g. Software No: 1MRS110019-001.

Suffix	Language combination
001	English - German
002	English - Swedish
003	English - Finnish
009	English - Russian

The REM 543 and REM 545 machine terminals differ from each other as to the number of digital inputs and outputs as follows:

Number of inputs/outputs	REM 543	REM 545
Digital inputs	15	25
Trip circuit supervision inputs	2	2
Power outputs (NO single-pole)	-	2
Power outputs (NO double-pole)	5	9
Signal outputs (NO)	2	2
Signal outputs (NO/NC)	5	5
Self-supervision outputs	1	1

7.2. Hardware versions of REM 543 and REM 545

For the number of digital inputs and outputs of the machine terminals, refer to section “Order number”. The number of matching transformers, sensor inputs and analog inputs and outputs, and the auxiliary voltage range vary between the different hardware versions of REM 54_. Moreover, both REM 543 and REM 545 can be supplied with an RTD/analog module. For more detailed information about the hardware of the machine terminals, refer to section “Hardware versions” on page 11.

7.3. Software configuration

Each machine terminal allows different software configurations based on separate functions (refer to section “Functions of the machine terminal” on page 23). Functions included in the selected functionality level (refer to section “Ordering Information” on page 91) can be activated within the scope of the I/O connections and considering the total CPU load of the functions.

8. Revision History of REM 54_

8.1. Revision identification

The main releases of the REM 54_ machine terminals are differentiated with the software revision letter in the order number of the machine terminal and the corresponding software number, both of which are printed on the marking strip on the front panel of the terminal, for example as follows:

Order No: REM543CM212AAAA

Software No: 1MRS110019-001

Table 8.1.-1 Revisions of REM 54_

Product	Revision	Software No	Release
REM 543	A	1MRS110010-001	Release 1.5 (Dec 1998)
	B	1MRS110018-00_	Release 2.0 (May 2000)
	C	1MRS110022-00_	Release 2.5 (Jun 2002)
REM 543 (RTD1)	A	1MRS110019-00_	Release 2.0 (May 2000)
	B	1MRS110023-00_	Release 2.5 (Jun 2002)
REM 545	A	1MRS110020-00_	Release 2.0 (May 2000)
	B	1MRS110024-00_	Release 2.5 (Jun 2002)
REM 545 (RTD1)	A	1MRS110021-00_	Release 2.0 (May 2000)
	B	1MRS110025-00_	Release 2.5 (Jun 2002)

The revision letter determines the main release which may involve functional additions and changes to the product. The changes included in each revision compared to the previous one are described in more detail below.

8.2. Release Q4/08

8.2.1. Changes and additions to earlier released revisions

Hardware and mechanics

- Voltage threshold for digital inputs:

- New hardware versions with power supply (PS1/240 V High) 110/120/220/240 V AC or 110/125/220 V DC with the digital input nominal voltage 220 V DC and threshold voltage 155 V DC.

8.2.2. Configuration, setting and SA system tools

The following tool versions are needed to support the new functions and features of the release of REM 54_:

- CAP 505 Relay Product Engineering Tools; CAP 505 v. 2.4.0-3
- CAP 501 Relay Setting Tools; CAP 501 v.2.4.0-2
- LNT 505 LON Network Tool; LNT 505 v. 1.1.1-1
- MicroSCADA Pro Application Library LIB 510 v.4.2-3

Technical Reference Manual, General

- REM 543/545 Connectivity package v.2.2
- Communication Engineering Tool for COM610, SPA-ZC 40x or MicroSCADA Pro SYS 600 and COM 500
- SCL Importer in MicroSCADA Pro SYS 600 and COM 500

8.3. Patch release, SW build 4.00

8.3.1. Changes and additions to earlier released revisions

Protocols & communication

- Faster communication with SPA-ZC 302
- Faster communication with SPA-ZC 400 with limited GOOSE messages

8.3.2. Configuration, setting and SA system tools

The following tool versions are needed to support the new functions and features of patch release of REM 54_:

- CAP 505 Relay Product Engineering Tools; CAP 505 v. 2.4.0-2
- CAP 501 Relay Setting Tools; CAP 501 v. 2.4.0-2
- LNT 505 LON Network Tool; LNT 505 v. 1.1.1-1
- MicroSCADA Pro Application Library LIB 510 v. 4.2-3
- REM 543/545 Connectivity package v. 2.2
- Communication Engineering Tool for COM610, SPA-ZC 40x or MicroSCADA Pro SYS 600 and COM 500
- SCL Importer in MicroSCADA Pro SYS 600 and COM 500

8.4. Release 2.5

8.4.1. Changes and additions to earlier released revisions

General

- Filtering times of digital inputs
- New type of RTD input: Ni 120US
- Technical data corrections

Function blocks

- Modification of Diff3, the high-impedance or flux-balance based differential protection function block
 - adjustable time setting added
- NOC3Low and NEF1Low: addition of ANSI inverse time curve

For further information about the changes above, refer to the function block descriptions on the CD-ROM Technical Descriptions of Functions.

New protection functions

Function	Description
SCVCSt1	Synchro-check/voltage check function, stage 1
SCVCSt2	Synchro-check/voltage check function, stage 2
DOC6Low	Three-phase directional O/C function, low-set stage l> ->
DOC6High	Three-phase directional O/C function, high-set stage l>> ->
DOC6Inst	Three-phase directional O/C function, instantaneous stage l>>> ->

Protocols and communication

- Modbus communication protocol (RTU and ASCII implementation)
- SMS bus
 - parallel communication and support
 - simultaneous use of the rear connectors (SPA - LON and Modbus - SPA)

Tools

- Protocol selection (“Protocol 2”)
- Downloading of POD tables in connection with Modbus configurations

8.4.2.**Configuration, setting and SA system tools**

The following tool versions are needed to support Release 2.5 revisions of REM 54_:

- CAP 505 Relay Product Engineering Tools; CAP 505 v. 2.1.1-3
- CAP 501 Relay Setting Tools; CAP 501 v. 2.1.1-1
- LNT 505 LON Network Tool; LNT 505 v. 1.1.1-1
- LIB 510 Library for MicroSCADA; LIB 510 v. 4.0.3-2

8.5.**Release 2.0****8.5.1.****Changes and additions to earlier released revisions****General**

- Additional scaling factor for setting the displacement error of current and voltage sensors. For further information refer to section “Technical data of the measuring devices” on page 41.
- Number of sensor types increased from 3 to 10 (each sensor channel can be set separately)
- New measuring device and signal GE1...3 to be used with the MEAI1...8 function blocks. For further information refer to the Technical Descriptions of Functions CD-ROM.
- Amount of measuring signal types for current and voltage increased
 - IL1b, IL2b, IL3b
 - U12b, U23b, U31b, U1b, U2b, U3b
 - Uob
- Improved storing, shorter storing time

Technical Reference Manual, General

- New language versions:
 - English - Swedish
 - English - Finnish
- An informative parameter, `Config. capacity`, added (Main menu/Configuration/General/Config. capacity). For further information refer to the Configuration Guideline (1MRS750745-MUM).
- Menu descriptions of virtual I/Os changed to match the names in tools
- 48-hour capacitor back-up for the internal clock of the machine terminal
- Selection of latching feature for the Start LED can be stored in the non-volatile memory

Function blocks

- Function block revision added (uploading of the function block list to CAP 505)
- Measurement function blocks: outputs indicating the status of warning and alarm limits added
- Under- and overvoltage protection function blocks `UV3_` and `OV3_`:
 - phase-selective start outputs added
 - control setting parameter `Oper. hysteresis` added for adjusting the level of a comparator (for more information, refer to the CD-ROM Technical Descriptions of Functions)
- EVENT230 function block: input interface changed
- Changes to input names in the following function blocks: `UV3Low`, `UV3High`, `OV3Low`, `OV3High`, `MEVO3A`, `CMVO3`
- MEPE7, the function block for power and energy measurement:
 - Events for energy (E), apparent power (S), and $\cos \varphi$ added
 - Time-based delta event sending added
- Start time range of the `MotStart` function block changed from 0.3...80.0 s to 0.3... 250 s

For further information about the above changes, refer to the function block descriptions on the CD-ROM Technical Descriptions of Functions.

New protection functions

Function	Description
Diff3	High-impedance or flux-balance based differential protection for generators and motors
FuseFail	Fuse failure supervision
PREV3	Phase reversal protection
PSV3St1	Phase-sequence voltage protection, stage 1
PSV3St2	Phase-sequence voltage protection, stage 2
UI6Low	Three-phase underimpedance protection, low-set stage
UI6High	Three-phase underimpedance protection, high-set stage
OE1Low	Overexcitation protection, low-set stage
OE1High	Overexcitation protection, high-set stage

New measurement functions

Function	Description
MEAI1	General measurement 1 / analog input on RTD/analog module
MEAI2	General measurement 2 / analog input on RTD/analog module
...	
MEAI8	General measurement 3 / analog input on RTD/analog module
MEAO1	Analog output 1 on RTD/analog module
MEAO2	Analog output 2 on RTD/analog module
MEAO3	Analog output 3 on RTD/analog module
MEAO4	Analog output 4 on RTD/analog module

New condition monitoring functions:

Function	Description
CMGAS3	Three-pole gas pressure monitoring

Protocols and communication

- Uploading/downloading of the Relay Configuration Tool project (RCT) from/to the machine terminal for the Relay Configuration Tool
- Parallel communication support: simultaneous use of the front and rear connectors was not allowed earlier

Hardware and mechanics

- New mechanics
- External display module
- New CPU module with a communication port for an external display module
- New hardware versions with an RTD/analog module
- One sensor channel added (total of 9 channels)
- Voltage threshold for digital inputs:
 - power supply 110/120/220/240 V AC or 110/125/220 V DC with the digital input voltage range 110/125/220 V DC
 - power supply 24/48/60 V DC with the digital input voltage range 24/48/60/110/125/220 V DC

Tools

- Uploading/downloading of the Relay Configuration Tool project (RCT in CAP 505) from/to the machine terminal via SPA or LON
- Uploading/downloading of settings (CAP501/CAP505) from/to the machine terminal via the rear serial port RS-485 of REM 54_ using LON
- Uploading of disturbance recordings to MicroSCADA and CAP 505 via SPA or LON

8.5.2.**Configuration, setting and SA system tools**

The following tool versions are needed to support the new functions and features of Release 2.0 revisions of REM 54_:

- CAP 505 Relay Product Engineering Tools; CAP 505 v. 2.0.0
- CAP 501 Relay Setting Tools; CAP 501 v. 2.0.0
- LNT 505 LON Network Tool; LNT 505 v. 1.1.1
- LIB 510 Library for MicroSCADA v. 8.4.3; LIB 510 v. 4.0.3

9. Abbreviations

AI	Analog input
CB	Circuit breaker
CBFP	Circuit breaker failure protection
CPU	Central processing unit
CT	Current transformer
DI	Digital input
DO	Digital output
EMC	Electromagnetic compatibility
GND	Ground
HMI	Human-machine interface
HSPO	High-speed power output
I/O	Input/output
IRF	Internal relay fault
LCD	Liquid-crystal display
LED	Light-emitting diode
LON	Locally operating network
L/R	Local/remote
LV	Low voltage
MIMIC	A graphic configuration picture on the LCD of a relay
MV	Medium voltage
NO/NC	Normally open/ normally closed
PCB	Printed circuit board
PLC	Programmable logic controller
PO	Power output
POD	Protocol object dictionary
PS	Power supply
RTD	Resistance temperature device
SMS	Substation monitoring system
SNVT	Standard network variable type
SO	Signal output
SPA	Data communication protocol, developed by ABB
SPACOM	ABB product family

10.**Index****A**

Alarm indication.....	75
Alarm modes	31
Alarm texts	31
Analog channels	37
Analog interface	12, 13, 14, 15, 16, 17, 18, 19
Analog outputs	12, 13, 14, 15, 16, 17, 18, 19, 61
Application	20
Auxiliary power.....	35, 36

C

Calculated analog channels	43
Communication	20, 82
Condition monitoring functions	27
Configuration	22, 30
Connections	87
Connectors.....	87
Control functions.....	25
CPU load	20, 92
CPU module	11, 12, 13, 14, 15, 16, 17, 18, 19, 97, 98
Current measurement	23
Current sensor	12, 13, 14, 15, 16, 17, 18, 19, 37, 41
Current transformer	12, 13, 14, 15, 16, 17, 18, 19, 23, 41

D

Digital inputs	12, 13, 14, 15, 16, 17, 18, 19, 43
Digital outputs	12, 13, 14, 15, 16, 17, 18, 19, 48
Dimensions	83
Double-pole power output.....	12, 13, 14, 15, 16, 17, 18, 19, 50
Downloading the configuration.....	30

E

Electromagnetic compatibility	81
Environmental conditions	21, 81
Event recording	83
External display module	12, 13, 14, 15, 16, 17, 18, 19, 88

F

Fault codes.....	65
Fault indication.....	65
Filter time of a digital input.....	45
Functionality.....	20
Functions	21, 23

H	
Hardware	11, 39, 92
High-speed double-pole power output (HSPO)	49
HMI	12, 13, 14, 15, 16, 17, 18, 19, 20, 33, 74
I	
Interlocking LED	32, 78
Inversion of a digital input	45
IRF	65
IRF output.....	12, 13, 14, 15, 16, 17, 18, 19, 65
L	
Latched alarm	77
LED	31, 75
Logic functions.....	28
LON network configuration	22, 32
LON Network Tool	32
M	
Matching transformer	37
Measurement functions	20, 25
Measuring devices	41
Mechanical dimensions	83
MIMIC picture.....	31
Modbus	20
N	
Non-latched alarm	76
O	
Order number.....	12, 13, 14, 15, 16, 17, 18, 19, 37, 91
Ordering.....	91
Oscillation suppression.....	47
Overtemperature indication	36
P	
Parameterization	33
Parameters	33, 34
PC connection.....	67
PLC functions	20, 30
POD	33
Power direction	86
Power output (PO).....	12, 13, 14, 15, 16, 17, 18, 19, 48, 80
Power supply	12, 13, 14, 15, 16, 17, 18, 19, 35, 79
Protection functions.....	20, 23
Pulse counters	46

R	
Rated frequency.....	33
Rated values	40
Relay Configuration Tool.....	22, 30, 39
Relay Mimic Editor.....	22, 31
Relay Setting Tool.....	34
Revisions of REM 54_	93
Rogowski coil.....	23, 37, 41
RTD/analog inputs	12, 13, 14, 15, 16, 17, 18, 19, 52, 80
RTD/analog module	12, 13, 14, 15, 16, 17, 18, 19
S	
Scaling factors	40
Self-supervision (IRF).....	65
Sensor channels	12, 13, 14, 15, 16, 17, 18, 19
Serial communication.....	66
Service.....	90
Signal output (SO).....	12, 13, 14, 15, 16, 17, 18, 19, 51, 80
Single-pole power output	12, 13, 14, 15, 16, 17, 18, 19, 50
SMS bus	71, 94
Software	92
Standard functions.....	28
Storing of parameters	34
T	
Temperature supervision	36
Terminal connections	87
Terminal diagrams.....	84
Tests	81
Threshold voltage.....	12, 13, 14, 15, 16, 17, 18, 19
Transformers	12, 13, 14, 15, 16, 17, 18, 19
Trip circuit supervision	12, 13, 14, 15, 16, 17, 18, 19, 63
V	
Virtual channel	43
Voltage divider.....	23, 37, 42
Voltage measurement.....	23
Voltage transformer.....	12, 13, 14, 15, 16, 17, 18, 19, 23, 41



ABB Oy

Distribution Automation

P.O. Box 699

FI-65101 Vaasa

FINLAND

Tel. +358 10 22 11

Fax. +358 10 224 1094

www.abb.com/substationautomation