

## VOL-40,5

# Outdoor voltage transformers

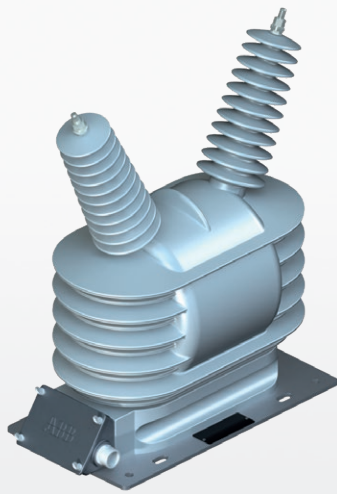

### Application

The VOL-40,5 are outdoor double-pole voltage transformers. Voltage transformers are made in epoxy resin insulation and are designed for networks with the highest voltage for equipment up to 40,5 kV.

The double-pole voltage transformers are generally connected between two phases in three-phase network, usually in the 'V' type of connection. The majority of the transformers are equipped with a single secondary winding for measurement purpose. One of the terminals of each secondary winding must be earthed during the transformer operation.

### Construction features

The primary and secondary coils are wound using special winding and shielding techniques for improved voltage stress distribution. Each coil is carefully insulated to provide a high dielectric medium between layers. The completed winding structure and core are assembled to a support frame.

For insulation and protection, the assembly is cast in hydrophobic cycloaliphatic epoxy (HCEP) using automatic pressure gelation. The HCEP material

offers superior arc track, ozone, and ultraviolet resistive properties while maintaining physical strength. The hydrophobic surface properties of HCEP ensure highly reliable performance in wet or humid environments.

### Terminals

Primary terminals are M12 copper pin is with nickel plated coating.

Brass M6 secondary terminals accommodate 2.5 mm<sup>2</sup> through 6 mm<sup>2</sup> wire.

The ground terminal M8 (or M12 in version with rails) has galvanic connection with grounding terminal in inside terminal box of the transformer.

### Junction box (secondary terminal box)

The secondary terminal box has mounted one PG21 cable gland. The secondary terminal box is suitable to mount maximum two cable glands. The screws of terminal box lid are suitable to use seals.

Terminal box has IP54 protection class according to the following standards: EN 60529: 1993/IEC 60529: 1989 + A1: 1999.

### Baseplate

The base plate or rails are constructed of corrosion resistant aluminium and are secured to the transformer body.

### Mounting

The VOL-40,5 can be mounted in vertical position. Four holes Ø14 mm in the base plate or in the rails are dedicated to mounting voltage transformer to the support.

### Standards

This unit meets IEC 61869-3, PN-EN 61869-3 standards.

**Unit performance**

Highest voltage for equipment (r.m.s.)	[kV]	up to 40.5
Rated power-frequency withstand voltage (r.m.s.)	[kV]	up to 95
Rated lightning impulse withstand voltage (peak)	[kV]	up to 200
Rated frequency	[Hz]	50, 60
Rated primary voltages	[kV]	up to 38
Voltage factor	[-]	1,2xUn/continuous
Max. number of secondary winding	[-]	2 (max. 2 secondary windings with voltage range: 100V – 120V, other voltage on request)
Rated secondary voltages	[V]	up to 230
Max. rated output*/ accuracy class	[VA/-]	50/cl.0,2; 100/cl.0,5; 200/cl.1; 500/cl.3, cl.3P or 6P
Thermal limiting output	[VA]	700
Creepage distance	[mm]	1325
Approximate weight	[kg]	70
Ambient temperature	[°C]	-40 ÷ +40
Standards	[-]	IEC 61869-3; PN-EN 61869-3
Versions	[-]	1. Base plate 2RFA016266 - Fig.1 2. Rails 2RFA016267 - Fig.2

\* sum of rated output per voltage transformers

Other value of parameters: rated output; accuracy class; rated frequency; voltage factor; rated secondary voltage; rated primary voltage; version with reconnectable voltage (on secondary side); version with fuse of secondary winding, can also be supplied on request.

## Dimension drawings

### VOL-40.5 with bottom plate 2RFA016266

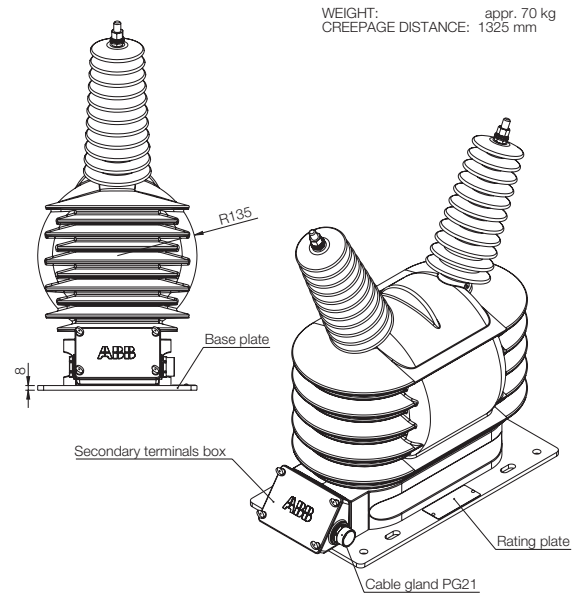
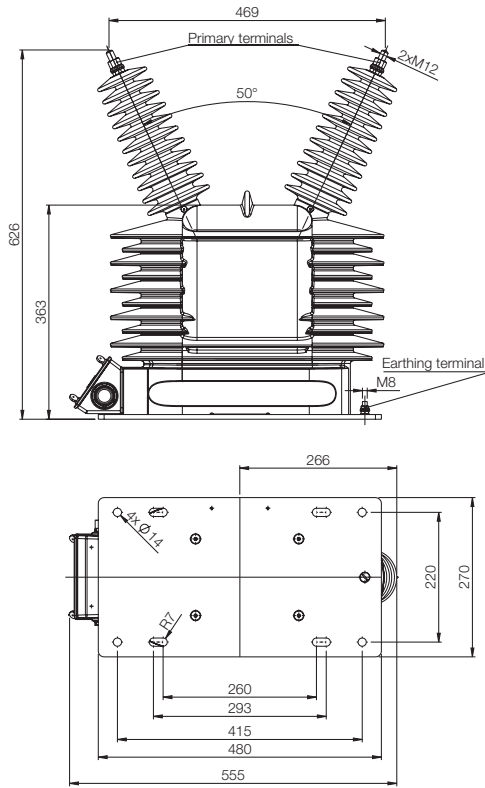

WEIGHT: appr. 70 kg  
CREEPAGE DISTANCE: 1325 mm

### VOL-40.5 with rails 2RFA016267

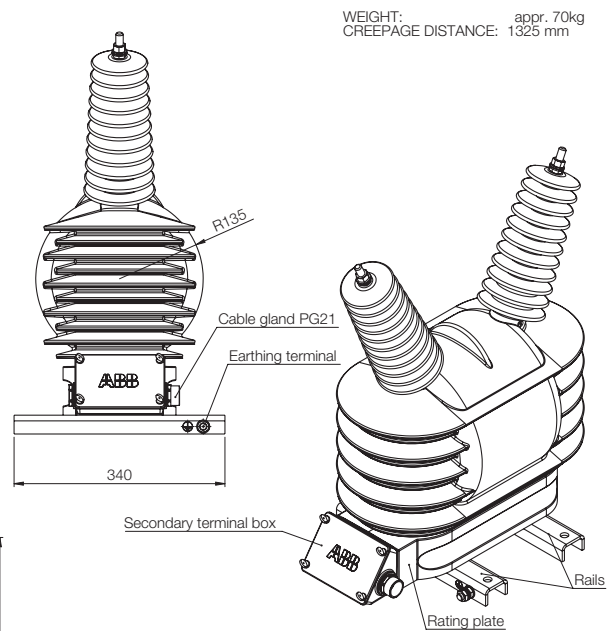
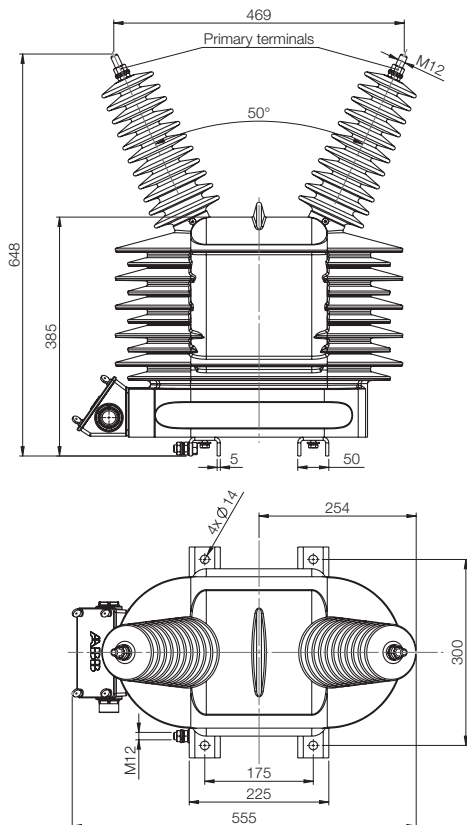

WEIGHT: appr. 70kg  
CREEPAGE DISTANCE: 1325 mm

---

**CONTACT US**

ABB s.r.o.  
EPDS Brno  
Videnska 117, 619 00 Brno,  
Czech Republic  
Tel.: +420 547 152 021  
+420 547 152 854  
Fax: +420 547 152 626  
E-mail: kontakt@cz.abb.com

---

**NOTE**

We reserve the right to make technical changes or modify the contents of this document without prior notice. With regard to purchase orders, the agreed particulars shall prevail. ABB does not accept any responsibility whatsoever for potential errors or possible lack of information in this document.

We reserve all rights in this document and in the subject matter and illustrations contained therein. Any reproduction, disclosure to third parties or utilization of its contents - in whole or in parts - is forbidden without prior written consent of ABB.

Copyright© 2019 ABB  
All rights reserved