



## Features

- Comprehensive numerical feeder protection relay consisting of two multi-function protection relay modules and a flexible auto-reclose relay module
- Overall scheme comprising time overcurrent protection, short-circuit protection, phase discontinuity protection, non-directional and directional earth-fault protection, general earth-fault supervision, auto-reclose facilities, circuit-breaker failure protection and circuit-breaker condition monitoring
- 1 A and 5 A tappings on the energizing current inputs of the overcurrent and non-directional earth-fault protection and 0.2 A and 1 A tappings on the energizing inputs of the directional earth-fault protection
- Selectable rated energizing input voltages of the directional earth-fault protection: 100 V, 110 V or 120 V
- Four heavy-duty relays for CB tripping and five weak current relays for signalling purposes
- Double-pole or single-pole circuit-breaker control
- Five configurable control inputs for the external control of the protection stages and the auto-reclose module
- Remote control of the circuit-breaker via the auto-reclose module
- Local man-machine communication via push-buttons and a digital display on the front panels of the protection relay modules
- Serial interface for connecting the relay to higher-level data acquisition systems, local or remote control systems or other host systems
- Local fault indication by means of LED indicators with memory functions and the digital display
- High immunity to electrical and electromagnetic interference
- Continuous self-supervision of relay hardware and software for enhanced system reliability and availability
- Auto-diagnostic fault indication to facilitate fault location and repair
- Powerful software support for parameterization of the relay, for reading measured and recorded values, events, etc., and for storing readings
- Member of the SPACOM product family and ABB's Substation Automation system
- CE marking according to the EC directive for EMC

## Application

The feeder protection relay SPAA 341 C is used for the protection of radial isolated neutral networks or resistively and/or resonant earthed networks. The feeder protection relay provides time overcurrent protection, short-circuit protection, earth-fault protection and phase discontinuity protection. Several earth-fault protection principles are available, including directional and non-directional earth-fault protection and residual overvolt-

age protection. The feeder protection relay also incorporates a flexible multi-shot auto-reclose module for three-phase auto-reclosing of circuit breakers.

The system reliability and availability is enhanced by a built-in circuit-breaker failure protection function, a circuit-breaker condition monitor and a sophisticated hardware and software self-supervision system.

## Design

The feeder protection relay is provided with energizing inputs for three phase currents, one residual or neutral current and one residual voltage. The relay is also provided with five control inputs for external control signals such as blocking signals, CB position signals, auto-reclose control signals, etc. Further, the feeder protection relay is equipped with nine output relays for CB control, signalling, etc.

The feeder protection relay consists of two protection relay modules and an auto-reclose relay module. The modules are withdrawable as are the power supply module and the I/O relay module, which are located behind the system front panel.

The combined overcurrent and earth-fault module SPCJ 4D28 includes four protection units, i.e. an overcurrent unit, an earth-fault unit, a phase discontinuity unit and a circuit-breaker failure protection unit.

The three-phase overcurrent unit comprises three overcurrent stages, i.e. a low-set stage  $I_{>}$ , a high-set stage  $I_{>>}$  and a super high-set stage  $I_{>>>}$ . The low-set stage can be given definite time characteristic or inverse time characteristic while the high-set stage and the super high-set stage have a definite time characteristic.

The non-directional earth-fault unit includes two protection stages, i.e. a low-set stage  $I_{0>}$  and a high-set stage  $I_{0>>}$ . The low-set stage can be given definite time characteristic or inverse time characteristic while the high-set stage features definite time characteristic.

The phase discontinuity protection unit measures the phase unbalance and features definite time characteristic.

The circuit-breaker failure protection unit is activated by the main trip signal of the overcurrent and earth-fault unit and it provides a second trip signal to be routed to a back-up circuit breaker if the main CB fails to operate.

The directional/non-directional earth-fault module SPCS 2D26 contains two protection units, i.e. an earth-fault unit and a circuit-breaker failure protection unit.

The earth-fault unit measures the residual/neutral current and the residual voltage and it can be given directional function or non-directional function. It features two protection stages, i.e. a low-set stage  $I_{01>}$  and a high-set stage  $I_{02>}$ , both with definite time characteristic.

The earth-fault unit can also be set to measure the residual voltage alone. In this case the earth-fault unit forms a residual overvoltage protection unit with three protection stages, i.e.  $U_{0b>}$ ,  $U_{01>}$  and  $U_{02>}$ , all with definite time characteristic.

The flexible auto-reclose unit SPCT 5D54 can be started via the start and/or trip signals of the protection modules or an external control signal. The module has three start lines, which means that the module can be given several different auto-reclose sequences, depending on the signal starting the auto-reclose sequence. The module can perform five successive auto-reclose shots, provided the circuit breaker is capable of the same.

The auto-reclose module incorporates a number of counters for recording detailed auto-reclose statistics and an integrated circuit-breaker condition monitor which alarms, when the circuit breaker needs maintenance.

### Data communication

The relay is provided with a serial interface on the rear panel. By means of a bus connection module type SPA-ZC 17 or SPA-ZC 21 the relay can be connected to the fibre-optic SPA bus. The bus connection module type SPA-ZC 21 is powered from the host relay, whereas the bus connection module SPA-ZC 17 is provided with a built-in power unit, which can be fed from an external secured power source. The relay communicates with higher-level data acquisition and control systems over the SPA bus.

### Output relays and circuit breaker control

The feeder protection relay is provided with nine auxiliary output relays, four of which are heavy-duty output relays for the direct control of the circuit breaker. Single-pole or double-pole circuit breaker control can be used. One of the five signalling relays is permanently allocated for the self-supervision system. The function of the other four relays can be defined by the user.

### Self-supervision

The relay incorporates a sophisticated self-supervision system with auto-diagnosis, which increases the availability of the relay

and the reliability of the system. The self-supervision system continuously monitors the hardware and the software of the relay. The system also supervises the operation of the auxiliary supply module and the voltages generated by the module.

When a permanent internal relay fault is detected, the IRF indicator on the relay front panel is lit. At the same time the output relay of the self-supervision system operates and a fault message is transmitted to the higher-level system over the serial bus. Further, in most fault situations, a fault code is shown in the display of the protection relay module. The fault code indicates the type of the fault that has been detected.

### Auxiliary supply voltage

The auxiliary supply of the relay is obtained from an internal plug-in type power supply module. Two auxiliary power module versions are available: type SPGU 240A1 for the supply voltage range 80...265 V ac/dc and type SPGU 48B2 for the supply voltage range 18...80 V dc. The power supply module forms the internal voltages required by the protection relay and the I/O module.

## Technical data

Table 1: Energizing inputs, current inputs

Terminals		X0/25-27	X0/1-3 X0/4-6 X0/7-9 X0/37-39 X0/25-26	X0/1-2 X0/4-5 X0/7-8 X0/37-38
Rated current $I_n$		0.2 A	1 A	5 A
Thermal current withstand	continuously	1.5 A	4 A	20 A
	for 10 s	5 A	25 A	100 A
	for 1 s	20 A	100 A	500 A
Dynamic current withstand	Half-wave value	50 A	250 A	1250 A
Input impedance		<750 m $\Omega$	<100 m $\Omega$	<20 m $\Omega$

Table 2: Energizing inputs, voltage inputs

Terminals	X0/28-29
Rated voltage $U_n$	100 V, 110 V or 120 V
Continuous voltage withstand	$2 \times U_n$
Rated burden of voltage input at $U_n$	<0.5 VA
Rated frequency $f_n$ , according to order	50 Hz or 60 Hz

Table 3: Output contact ratings

Type of contact		Tripping	Signalling
Terminals		X1/15-16, 11-12-13-14 X2/1-2, 3-4	X2/5-6, 7-8, 9-10-11 X2/12-13, 14-15-16
Rated voltage		250 V ac/dc	
Thermal withstand capability	Carry continuously	5 A	5 A
	Make and carry for 0.5 s	30 A	10 A
	Make and carry for 3 s	15 A	8 A
Breaking capacity for dc, when the control/ signalling circuit time constant $L/R \leq 40$ ms, at the control voltage levels	220 V dc	1 A	0.15 A
	110 V dc	3 A	0.25 A
	48 V dc	5 A	1 A
Contact material		AgCdO <sub>2</sub>	

**Table 4: Control input, communication and power supply**

External control input	Blocking inputs	Terminal numbers	X1/1-2, 3-4
	CB position message input	Terminal numbers	X1/5-6
	Auto-reclose feedback inputs	Terminal numbers	X1/7-8, 9-10
	Control voltage	Operative voltage range	18...250 V dc or 80...250 V ac
Current drain of activated control input		2...20 mA	
Data communication	Transmission mode		Fibre-optic serial bus
	Data code		ASCII
	Selectable data transfer rates		4800 or 9600 Bd
	Bus connection module, powered from the host relay	for plastic core cables	SPA-ZC 21 BB
		for glass fibre cables	SPA-ZC 21 MM
	Bus connection module, powered from the host relay or from an external power source	for plastic core cables	SPA-ZC 17 BB
for glass fibre cables		SPA-ZC 17 MM	
Auxiliary supply voltage	Terminal numbers		X0/61-62
	Power supply and I/O modules, rated voltages and operative range	SPGU 240A1	110/120/230/240 V ac, 110/125/220 V dc, 80...265 V ac/dc
		SPGU 48B2	24/48/60 V dc, 18...80 V dc
	Power consumption	under quiescent conditions	~10 W
under operating conditions		~15 W	

**Table 5: Relay module SPCJ 4D28, overcurrent unit**

Features		Stage I>	Stage I>>	Stage I>>>
Start current	at definite time	$0.5...5.0 \times I_n$	$0.5...40.0 \times I_n$ and $\infty$	$0.5...40.0 \times I_n$ and $\infty$
	at inverse time	$0.5...2.5 \times I_n$	–	–
Start time, typically		70 ms	40 ms	40 ms
Operate time at definite time characteristic		0.05...300 s	0.04...300 s	0.04...30 s
Time/current characteristic at inverse time mode		Extremely inverse Very inverse Normal inverse Long-time inverse RI type inverse RXIDG type inverse	–	–
Time multiplier k		0.05...1.0	–	–
Reset time, typically		40 ms	40 ms	40 ms
Retardation time		<30 ms		
Reset ratio, typically		0.96		
Operate time accuracy at definite time mode		$\pm 2\%$ of set value or $\pm 25$ ms		
Accuracy class index E at inverse time mode		5	–	–
Operation accuracy		$\pm 3\%$ of set value	$\pm 3\%$ of set value	$\pm 3\%$ of set value

Technical data (cont'd)

**Table 6: Relay module SPCJ 4D28, earth-fault and phase discontinuity unit**

Features	Stage $I_{0>}$	Stage $I_{0>>}$	Stage $\Delta I>$
Start current	$0.1 \dots 0.8 \times I_n$	$0.1 \dots 10.0 \times I_n$ and $\infty$	$10 \dots 100\%$ and $\infty$
Start time, typically	70 ms	50 ms	150 ms
Operate time at definite time characteristic	0.05...300 s	0.05...300 s	1...300 s
Time/current characteristic at inverse time mode	Extremely inverse Very inverse Normal inverse Long-time inverse RI type inverse RXIDG type inverse	–	–
Time multiplier k	0.05...1.0	–	–
Reset time, typically	40 ms	40 ms	80 ms
Retardation time	<30 ms	<30 ms	–
Reset ratio, typically	0.96	0.96	0.90
Operate time accuracy at definite time mode	$\pm 2\%$ of set value or $\pm 25$ ms		
Accuracy class index E at inverse time mode	5	–	–
Operation accuracy	$\pm 3\%$ of set value	$\pm 3\%$ of set value	$\pm 1$ unit $\pm 3\%$ of set value

**Table 7: Directional/non-directional earth-fault relay module SPCS 2D26**

Features	Residual voltage stage $U_{0b}$	Low-set stage $I_{01>}$ or $U_{01>}$	High-set stage $I_{02>}$ or $U_{02>}$
Operation direction	–	forward or reverse	
Basic angle $\phi_b$ , selectable	–	$-90^\circ$ , $-60^\circ$ , $-30^\circ$ or $0^\circ$	
Operation sector $\Delta\phi$	–	$\pm 80^\circ$ or $\pm 88^\circ$	
Mode of operation	–	directional or non-directional	
Start current	–	$1.0 \dots 100\%$ of $I_n$	$1.0 \dots 100\%$ of $I_n$ or $\infty$ , infinite
Start voltage	$2.0 \dots 80.0\%$ of $U_n$	$2.0 \dots 80\%$ of $U_n$	$2.0 \dots 80\%$ of $U_n$ or $\infty$ , infinite
Start time, typ.	60 ms	80 ms	
Operate time	0.1...300 s	0.1...300 s	
Reset time, typ.	60 ms	80, 100, 500 or 1000 ms	100 ms
Drop-off/pick-up ratio, typ.	0.96		
Operate time accuracy	$\pm 2\%$ of set time or $\pm 25$ ms		
Operation accuracy	$\pm 3\%$ of set voltage	$\pm 3\%$ of set value + $0.0005 \times I_n$	

**Table 8: Auto-reclose relay module SPCT 5D54**

Number of auto-reclose shots	1...5
AR start delay time	0...10.0 s
Dead time	0.20...300 s
Discriminating time	0...30.0 s
Reclaim time	0.2...300 s
Final trip time	0.0...5.00 s
Length of CB close pulse	0.10...2.00 s
Length of CB open pulse	0.10...2.00 s
Operate time accuracy	$\pm 1\%$ of set value or $\pm 30$ ms

Table 9: Tests and standards

Test voltages	Dielectric test voltage (IEC 60255-5)		2 kV, 50 Hz, 1 min
	Impulse test voltage (IEC 60255-5)		5 kV, 1.2/50 $\mu$ s, 0.5 J
	Insulation resistance (IEC 60255-5)		>100 M $\Omega$ , 500 V dc
Disturbance tests	HF disturbance test (IEC 60255-22-1, class III)	Common mode	2.5 kV, 1 MHz
		Differential mode	1.0 kV, 1 MHz
	Fast transients (IEC 60255-22-4, class III and IEC 60801-4, level IV)	Power supply inputs	4 kV, 5/50 ns
		Other inputs	2 kV, 5/50 ns
	Electrostatic discharge test (IEC 60255-22-2 and IEC 60801-2, class III)	Air discharge	8 kV
Contact discharge		6 kV	
Mechanical environmental tests	Vibration test (IEC60255-21-1)		class 2
	Shock/bump test (IEC 60255-21-2)		class 2
	Seismic test (IEC 60255-21-3)		class 2
Environmental conditions	Service temperature range		-10...+55°C
	Transport and storage temperature range (IEC 60068-2-8)		-40...+70°C
	Temperature influence		0.2%/°C
	Damp heat test, cyclic (12 h + 12 h) (IEC 60068-2-30)		+55°C, RH=93...95%, 6 cycles
	Degree of protection by enclosure of flush-mounted relay case (IEC 60529)		IP 54
	Weight of fully equipped relay, including flush-mounted relay case		6 kg

Block diagram

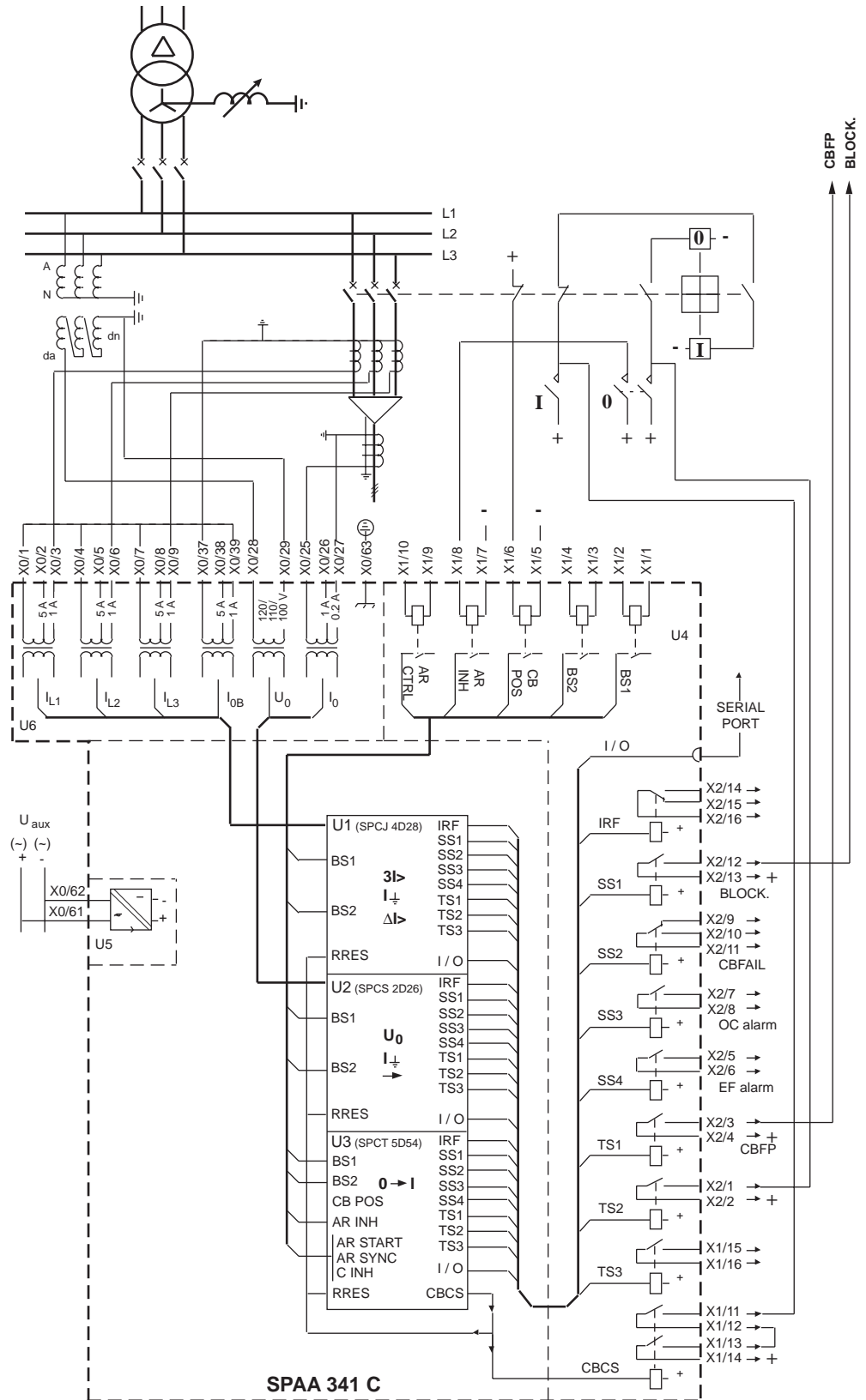

Fig. 1 Block diagram and sample connection diagram

**Mounting and dimensions**

**Flush mounting**

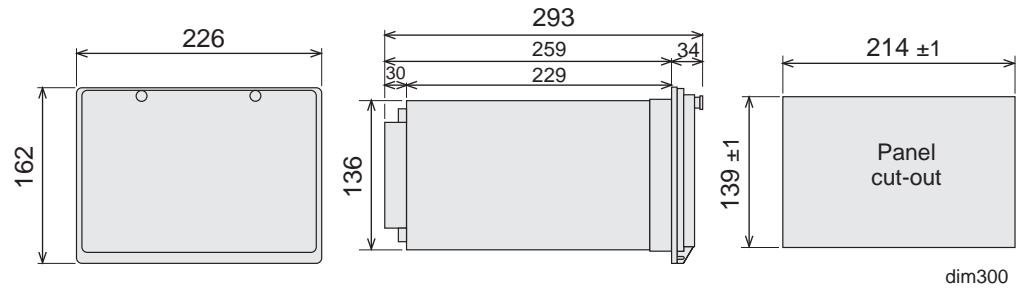
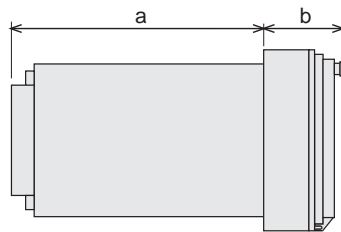

Fig. 2 Flush-mounting relay case (dimensions in mm)

**Semi-flush mounting**



Raising frame	a	b
SPA-ZX 301	219	74
SPA-ZX 302	179	114
SPA-ZX 303	139	154

SFM300\_1

Fig. 3 Semi-flush mounting relay case (dimensions in mm)

**Mounting in 19 inch cabinets and frames**

An ancillary mounting plate, height 4U (~177 mm), is recommended to be used when the protection relays are to be mounted in 19 inch frames or cabinets. The ancillary mounting plate type SPA-ZX 304 accommodates two size 300 relays and type SPA-ZX 305 one size 300 relay.

SPA-ZX304  
SPA-ZX305  
SPA-ZX201

SPA-ZX306  
SPA-ZX307  
SPA-ZX317  
SPA-ZX318

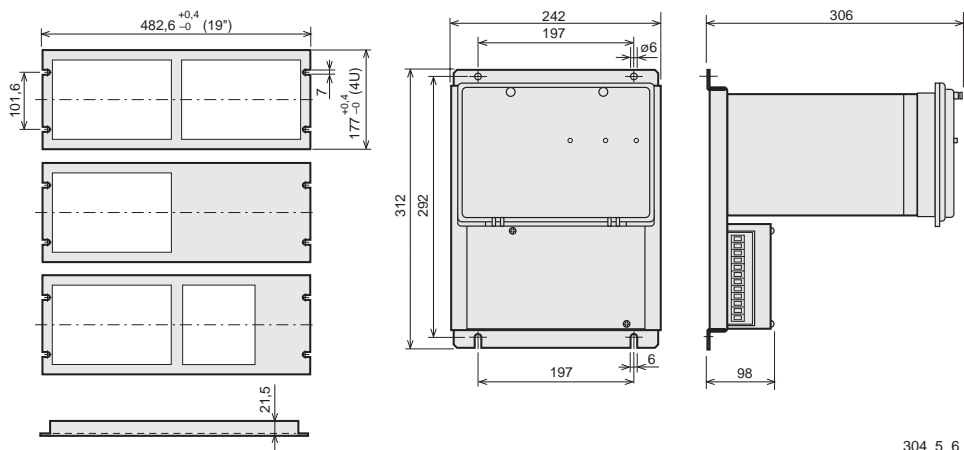

304\_5\_6

Fig. 4 Mounting cabinets and frames as well as projecting mounting (dimensions in mm)

## Ordering

## When ordering, please specify:

Ordering information	Ordering example
1. Type designation and quantity	SPAA 341 C, 5 pieces
2. Order number	RS 614 080-AA
3. Rated values	$I_n=5$ A, $U_n=110$ V, $f_n=50$ Hz
4. Auxiliary voltage	$U_{aux}=110$ V dc
5. Accessories	-
6. Special requirements	-

## Order numbers

Feeder protection relay SPAA 341 C_	
SPAA 341 C complete	RS 614 080-AA, CA, DA, FA
SPAA 341 C1, no AR module	RS 614 081-AA, CA, DA, FA
SPAA 341 C2, no dir. E/F module	RS 614 082-AA, CA, DA, FA
SPAA 341 C3, no dir. E/F module and no AR module	RS 614 083-AA, CA, DA, FA
SPAA 341 C4, no O/C & E/F module	RS 614 084-AA, CA, DA, FA
SPAA 341 C4, no O/C & E/F module and no AR module	RS 614 085-AA, CA, DA, FA
The last two letters of the order number indicate the rated frequency $f_n$ and the auxiliary voltage $U_{aux}$ of the relay as follows:	AA equals $f_n = 50$ Hz and $U_{aux} = 80\dots265$ V ac/dc
	CA equals $f_n = 50$ Hz and $U_{aux} = 18\dots80$ V dc
	DA equals $f_n = 60$ Hz and $U_{aux} = 80\dots265$ V ac/dc
	FA equals $f_n = 60$ Hz and $U_{aux} = 18\dots80$ V dc

Feeder protection relay SPAA 341 C_ including a test adapter type RTXP 18	
SPAA 341 C complete	RS 614 280-AA, CA, DA, FA
SPAA 341 C1, no AR module	RS 614 281-AA, CA, DA, FA
SPAA 341 C2, no dir. E/F module	RS 614 282-AA, CA, DA, FA
SPAA 341 C3, no dir. E/F module and no AR module	RS 614 283-AA, CA, DA, FA
SPAA 341 C4, no O/C & E/F module	RS 614 284-AA, CA, DA, FA
SPAA 341 C4, no O/C & E/F module and no AR module	RS 614 285-AA, CA, DA, FA
The last two letters of the order number indicate the rated frequency $f_n$ and the auxiliary voltage $U_{aux}$ of the relay as follows:	AA equals $f_n = 50$ Hz and $U_{aux} = 80\dots265$ V ac/dc
	CA equals $f_n = 50$ Hz and $U_{aux} = 18\dots80$ V dc
	DA equals $f_n = 60$ Hz and $U_{aux} = 80\dots265$ V ac/dc
	FA equals $f_n = 60$ Hz and $U_{aux} = 18\dots80$ V dc

## References

## Additional information

Colour brochure "Feeder protection relay SPAA 341 C"	1MRS 750003-MDS EN
User's manual and technical description "Feeder protection relay SPAA 341 C"	1MRS 750099-MUM EN





**ABB Oy**

P.O. Box 699  
FIN-65101 Vaasa, Finland  
Tel +358 10 224 000  
Fax +358 10 224 1094  
[www.abb.com/substationautomation](http://www.abb.com/substationautomation)