

# ABB Review













Special Report

Power  
Transmission



**The case for advanced power technologies.**



6		<b>HVDC superhighways for China</b> New HVDC transmission lines will carry electricity from the Three Gorges power plant to China's coastal regions.
13		<b>FACTS: improving the performance of electrical grids</b> How flexible AC transmission systems let utilities utilize their existing power lines more efficiently.
19		<b>ABB static var compensator stabilizes Namibian grid voltage</b> Namibia's long transmission lines give rise to unusual resonance. A new SVC has solved the problem.
25		<b>Advanced transformer control and monitoring with TEC</b> ABB's TrafoStar Electronic Control system models a transformer's actual state, allowing condition-based maintenance.
29		<b>Power systems consulting</b> A look at ABB power systems applications that integrate the domain competence of consulting experts with the latest software tools.
32		<b>Inform<sup>IT</sup> Wide Area Monitoring</b> PSG modules from ABB optimize asset utilization and can prevent the collapse of entire power networks.
37		<b>Industrial<sup>IT</sup> and the utility industry</b> How does the unique business environment of the utility industry benefit from Industrial IT?
42		<b>A battery energy storage system for Alaska</b> The world's largest BESS is providing essential back-up power for 90,000 people in the Fairbanks area.
47		<b>High-voltage cable technology</b> New XLPE cable system applications are available that can often compete with overhead lines.
53		<b>Powering Troll with HVDC Light<sup>TM</sup></b> New ABB technologies allow power to be supplied from land to platforms offshore.
57		<b>SwePol Link: new environmental standards for HVDC transmission</b> A unique HVDC link connects the electricity networks of Poland and Sweden.
61		<b>50 years of HVDC transmission</b> ABB has supplied more than half of the world's HVDC transmission capacity.

## City lights – a ‘power showcase’ built on technology and experience



In the aftermath of the recent power outages that plunged northeastern America and parts of Europe into darkness, politicians and utility owners rushed to debate the state of the world's power infrastructure. The outcome of this discussion has been general agreement that more investment is needed. But besides pointing out the vulnerability of outmoded infrastructure, the blackouts also served to make a point: wherever we live, we can no longer unquestioningly count upon a reliable supply of electrical power.

While these events gave a full-scale demonstration of what can happen when unstable power systems are driven to their operational limits, it is good to know that technologies are available that could almost certainly have prevented them from happening.

ABB is the world's leading provider of power technology products and systems. Constant investment in their further development has enabled our company to book several remarkable achievements in recent years.

For example, the world's largest battery system, which went into operation in Alaska in 2003, relies on ABB converter technology. Such systems bridge the time between power cuts and the start-up of emergency power generation. Alaska's new battery is designed to provide 40 MW of electrical power for 15 minutes. Other battery installations empowered by ABB converter technology are soon to go into operation in the United States.

ABB is the undisputed world leader in HVDC transmission. The power converters at the heart of this technology can make a huge contribution to grid stability. An HVDC power transmission link between the Three Gorges dam and Changzhou in China successfully completed all trials in 2003, and has the capability to operate at power levels of up to 3300 megawatts – a new world record! In Brazil ABB recently commissioned power transmission systems with a total length of 1267 kilometers. Construction of the systems, which included five substations and four series compensation banks, was completed in just twelve months.

The list goes on: the largest-ever gas-insulated substation for an important node in the Saudi Arabian high-voltage network; the world's longest underground high-voltage cable, developed and installed by ABB, stretching 177 kilometers from Victoria to South Australia and the winner of environmental and engineering awards.

ABB also holds the world record in high-power switching with its generator breakers, which can interrupt up to 200 kA at generator voltage levels of around 30 kV.

These records are solid proof of ABB's ability to provide world-class power technology, and of our company's strong commitment to research and development. Such performance is based on R&D programs that investigate the physical limits of current interruption and high-voltage insulation, or the application of semiconductor switching in our power electronics devices.

In addition to device-oriented R&D, ABB also looks at the 'big picture'. An example is our wide area approach to monitoring power system dynamics and network stability. Engineering tools we have developed enable us to analyze a complete grid in a very short time, and propose significant improvements.

This Special Report is devoted to ABB technologies which, by ensuring network stability, prevent the emergence of situations that could cause entire power systems to collapse. As an overview of our company's broad competence in this important area, the Report demonstrates ABB's ability to supply the utility industry with each and every part of its infrastructure. To make sure that electrical energy, upon which we depend so much, is available wherever and whenever it is needed.

H. Markus Bayegan  
Chief technology officer  
ABB Ltd

## Reliable grids, with power technologies from the market leader



The recent blackouts in the US and Europe have made more than just the media think about the critical importance of a secure and reliable supply of power. In our homes and throughout business and industry, the message is clear: no longer can we take for granted that power will simply be available everywhere, always.

Reliable power grids are the result of a partnership between governments, the electric utilities, consumers and, not least, the providers of the all-important technology that generates, transmits and distributes the power so efficiently. Over a country's power infrastructure flows its lifeblood – the energy that is essential to efficient running of our homes and offices, our factories and airports. Much of our future prosperity will depend on how we look after it.

Modern power systems are the result of continuous development and improvement which, over the years, has led to highly sophisticated and complex technologies. Their reliable operation is a tribute to the work of dedicated scientists, innovative engineers and experi-

enced business leaders. ABB has built its reputation in power technology on these three strengths.

Invention and innovation have a long tradition at ABB, and many of the key technologies upon which the power industry is founded were pioneered by our company. Our track record goes back more than a century, and includes the world's first three-phase power transmission system and the world's first self-cooling transformer. ABB also pioneered HVDC technology. To mark this achievement, our company will celebrate '50 years of HVDC' together with our customers in spring 2004.

It is this pioneering spirit that still drives us today. Recent breakthroughs include our HVDC Light™ technology, which extends the economical power range of high-voltage direct current transmission down to just a few megawatts and opens up new possibilities for improving quality in power grids.

Our utility and industrial customers around the world rely on proven power technologies, researched, developed and made by ABB. In power transmission and distribution, ABB is the recognized leader, with a world market share of some 20 percent.

Every fourth power transformer and high-voltage circuit breaker in the world comes from ABB. Some of our high-end products and systems – generator breakers, for example – have beaten even this proud record and captured more than half of the world market. The same is true in other important areas of the power sector, like high-voltage direct current (HVDC) transmission or flexible





alternating current transmission systems (FACTS).

State-of-the-art technologies such as HVDC and FACTS have precisely the qualities and capability that are required to prevent blackouts.

HVDC lets utilities solve two problems at the same time: using it to interconnect asynchronous power grids not only increases reliability, but also sets the stage for power trading across those grids. Most of the world's power networks were designed as national grids or as regional grids within a country. To facilitate open markets, these networks increasingly require HVDC interconnections.

With FACTS, utilities have devices at their disposal with which they can better utilize their existing infrastructure. FACTS provide an alternative to the construction of new transmission lines or power generation facilities by helping to maintain or improve the operating margins necessary for grid stability. As a result, consumers get more power without any extra strain being put on the environment, and projects are completed in a substantially shorter time.

Wide area monitoring (WAM) systems are another ABB offering that can prevent the collapse of entire power networks. GPS-synchronized current, voltage and frequency information gives power system operators a dynamic overview of the network conditions, and indicates the onset of conditions that, if unchecked, could cause system instability.

The power grids of the 21st century must incorporate such high-end tech-

nologies if they are to meet all the challenges that lie ahead. The blackouts of 2003 have served notice on the utilities, and demonstrated to the wider public, that power grids are vulnerable. In many countries, deregulation has all too often undermined the will to make necessary investments in high-end technologies.

A first step toward correcting this situation would be for regulators to offer investors, such as utilities and developers, special incentives that encourage them to install technologies which can be implemented quickly and increase the robustness of their transmission grids. In addition, quality standards for the power supply are needed to ensure power reliability and security.

ABB is ready to give its best: proven technology. But beyond superior power products, systems and services, there is another decisive contribution that ABB can make: speed. Short delivery times, guaranteed by a commitment to being fastest in everything we do, are in keeping with the prevailing sense of urgency. Power consumers around the world do not want to wait, and should not have to wait, one moment longer for a reliable power supply.

Peter Smits  
Member of the Executive Committee  
Head of Power Technologies Division  
ABB Ltd

# 高压直流

## HVDC superhighways for China

Leif Englund, Mats Lagerkvist, Rebati Dass



**When completed in 2009, the Three Gorges hydroelectric power plant being built on the middle reaches of the Yangtze river will be the largest of its kind anywhere in the world. With 26 turbine-generators, each rated at 700 MW, the total generating capacity will be a staggering 18.2 gigawatts.**

**No less challenging was the development of a technically and economically viable transmission system to carry this power to China's coastal regions, where it is urgently needed. After carrying out feasibility studies, the State Power Grid of China decided to build a hybrid AC-DC transmission system with over 10,000 km of HVAC and HVDC lines and about 2475 MVA of transformation capacity. The HVDC systems leaving the power plant site include bipolar transmission superhighways with ratings totaling more than 10,000 MW.**

Two of the world's most powerful and longest high-voltage direct current (HVDC) power transmission highways, each with a nominal rating of 3000 MW, are currently being installed in China. Being built by ABB in cooperation with the State Power Grid of China, they will eventually carry clean hydroelectric power from the Three Gorges power plant, situated on the middle reaches of the Yangtze river, to major load centers near Shanghai and Shenzhen on the Chinese coast.

High availability and a low forced outage rate were key goals from the start of the transmission projects. Advanced technologies, backed up by solid field experience and featuring built-in operational flexibility and low maintenance, are therefore being used in all the crucial areas.

To promote and ensure the success of the projects at all stages, close cooperation among ABB, the client, the client's design and inspection representatives, and local equipment manufacturers, was enshrined in the project contracts in the form of training and transfer of technology (see panel).

### Three Gorges power plant

The Three Gorges dam across the Yangtze river **1** is the largest of its kind in the world. Approximately 1.5 kilometers long and 185 meters (590 feet) high, its reservoir, with a normal water level of 175 meters (560 feet), will stretch over 560 kilometers (350 miles) upstream. The hydroelectric plant, with 26 turbine-

**1** Location of the Three Gorges power plant on the Yangtze river



generators rated at 700 MW, will have a total capacity of 18.2 gigawatts (the next-largest hydropower plant, Itaipu in Brazil, has a capacity of 12 GW). It is planned to later install a further six units in an underground powerhouse, taking the total capacity to 22.4 GW. This figure represents a more than six percent increase in China's current total installed capacity of 350 GW. The average yearly production of the Three Gorges plant will be 84.7 TWh [1,2].

### Power evacuation system

The power generated by the Three Gorges plant will be transmitted to grids in central China, east China, Sichuan and Guangdong via the Three Gorges Transmission System. With over 10,000 kilometers of HVAC and HVDC lines, this system will form the basis for a new national transmission grid, as the present seven regional power networks and five independent provincial networks will be combined to create two

### Transfer of technology (ToT) and local manufacturing

The contracts for both projects (3GC and 3GG) included extensive co-design, training and ToT programs.

The *co-design program* calls for the detailed design to be carried out jointly by design engineers and experts representing SPG and ABB.

*Training* of SPG's representatives covers maintenance and operation. Its goal is to ensure proper operation and maintenance of the projects by local personnel.

The *ToT programs* include know-how transfer in HVDC system design, control design and apparatus manufacturing to different organizations, ABB as well as non-ABB, in China. These programs will serve China's long-term objective of increased self-reliance in the design and production of high-tech HVDC equipment.



new regional networks. A national integrated grid is planned for 2015.

A major portion of the power will be carried to China's industrialized coastal areas in Shanghai and Shenzhen by means of four HVDC links 2:

- Gezhouba-Shanghai 1200-MW HVDC bipole, in operation since 1991.
- Three Gorges – Changzhou 3000-MW bipole (3GC), commissioned in May 2003.
- Three Gorges – Guangdong 3000-MW bipole (3GG), currently being commissioned.
- Three Gorges – Shanghai, 3000 MW, scheduled to be operating by 2007.

HVDC was chosen to transmit power from the Three Gorges plant for several reasons. Since the central and east China/Guangdong AC networks are not synchronized an AC transmission scheme would have required coordination, and it would have been very difficult to ensure adequate stability margins. HVDC allows controlled transmission of power between the networks, which also retain their independence. DC is also more economic in terms of construction costs and losses. Five series-compensated 500-kV AC lines would be necessary to transmit the same amount of power, and each line would require a larger right-of-way than one HVDC transmission line for 3000 MW.

### Unmatched experience with HVDC bulk power

ABB's record of large bipolar HVDC installations is unmatched. Prior to winning the Three Gorges contract, ABB had successfully built a whole series of large bipolar installations worldwide, for example:

- Itaipu (Brazil): two bipoles, each rated 3150 MW
- Intermountain Power Project (USA): one bipole, 1920 MW
- Rihand-Dadri Project (India): one bipole, 1500 MW

HVDC allows controlled transmission of power between the central and east China/Guangdong AC networks, which remain independent.

In October 2001 ABB won a second order, this time for the 3000-MW HVDC link between Three Gorges and Guangdong province. This fast-track project cuts 30 percent off the normal lead-

2 Four HVDC links will carry hydroelectricity from the Three Gorges power plant to China's coastal area and the industrial region of Guangdong

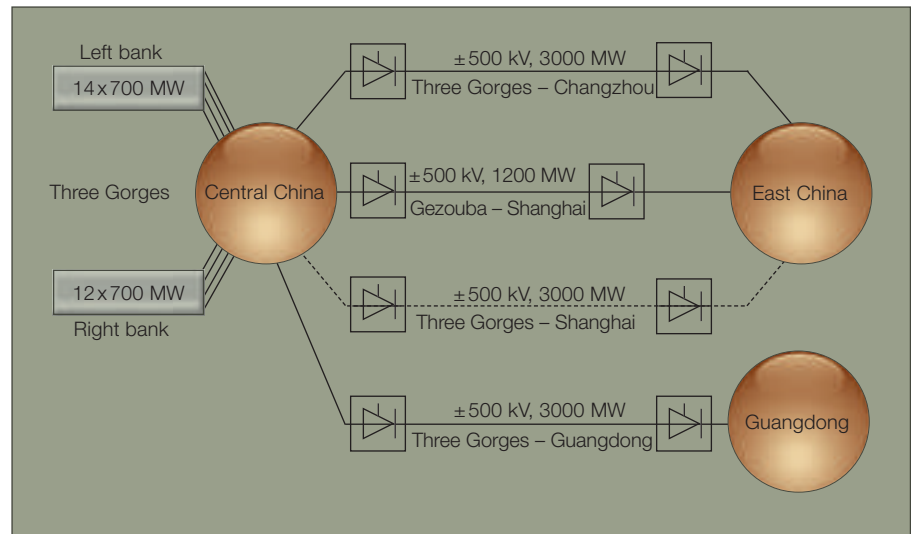

- Chandrapur-Padghe Project (India): one bipole, 1500 MW
- Quebec-New England Multiterminal (Canada/USA): three bipolar stations rated 2250/2250/2000 MW

time, enabling the first pole to be commissioned 28 months after signing of the contract. Similar in scope to the 3GC, it provides for more local content.

### Highway construction on schedule

ABB was awarded the first contract, to supply equipment for two converter stations for the 3000-MW HVDC bipolar link between Three Gorges and east China, in April 1999. This entrusted ABB with overall project responsibility, including the supervision of site work undertaken by the client. The contract also included ToT, covering HVDC system design, control design and equipment manufacturing. Approximately 85% of

the total contract value was for equipment or services provided by the ABB Group. The installation was commissioned on time in May 2003.

3 Indoor DC yard at Zhengping converter station (3GC)





The ToT covers HVDC system design as well as the design of the control and protection system. This project is well advanced and on schedule.

### 3GG benefits from 3GC

The 3GC project has established a world record by transmitting 1650 MW on a single pole. Since the Zhengping converter station is exposed to very heavy industrial pollution, the DC pole insulators had to be longer than those the manufacturers could provide. This and the difficulty of coordinating the external and internal insulation of extra-long bushings led to the decision to build indoor DC switchyards [3]. All high-potential DC equipment is installed indoors and all the DC neutral equipment is outdoors. There are four separate halls for each pole: one for switches, two for the DC filter capacitor banks, and one for the DC PLC capacitor bank.

The 3GG project is in a class of its own with regard to the very short 28 months to commissioning for monopolar and 32 months for bipolar operation. Here the knowledge and experience base provided by the 3GC project proved to be a huge asset. Areas that profited included the project engineering phase and the equipment design and delivery times, all of which could be significantly reduced. The cost benefit to the client was also considerable.

4 500-kV yard with SF<sub>6</sub> gas-insulated switchgear, at Jingzhou converter station (3GG)



To keep the AC yard of the 3GG Jingzhou converter station as small as possible, outdoor gas-insulated switchgear (GIS) is used for all of the ten 500-kV bays [4].

### The transmission systems

The 3GC and 3GG projects are both bipolar transmission schemes [3] with identical main primary and secondary equipment and operating strategies. The two 3GC converter stations are at Longquan (Hubei province) and Zhengping (in Changzhou, Jiangsu province), about 890 km apart. Longquan converter station is situated some 50 km from the Three Gorges Dam. The receiving station at Zhengping is approximately 200 km from Shanghai. Power will be transmitted eastward during the peak generation period and toward the central power grid whenever reservoir water needs to be conserved.

The converter station at the transmitting end of the 3GG project is located 16 km from Jingzhou city, about 135 km from the Three Gorges power plant. The receiving station is at Huizhou, in Guangdong province. Power will be transmitted over a distance of 940 km.

5 Power circuit arrangement used for the 3GC and 3GG projects

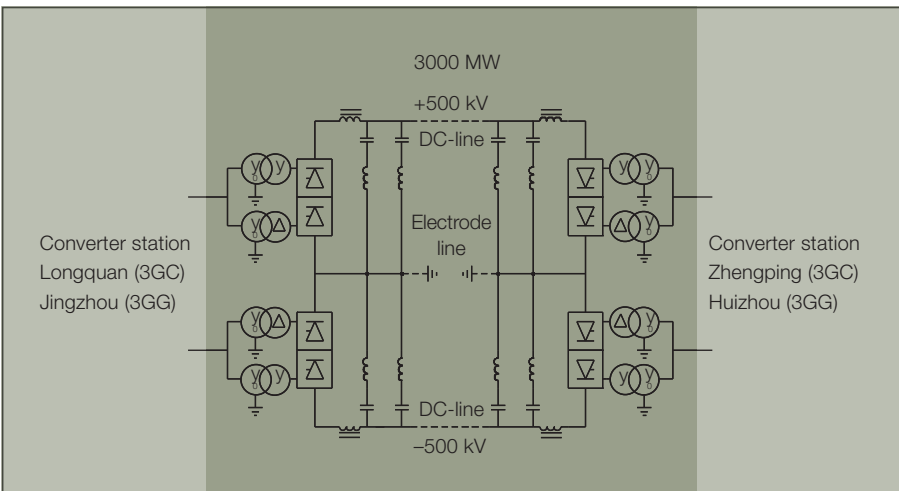

### Power ratings

The links are designed for a normal rating of 2 x 1500 MW under the (relatively conservative) specified conditions. They have been designed for a continuous overload capability of 3480 MW, and a 5-second overload capability of 4500 MW.

To minimize bipole outage the HVDC system can be operated with balanced bipolar currents, using the ground mats of the converter stations as temporary grounding, should the ground electrodes or their lines be out of service.

The nominal reverse power transfer capability is 90% of the rated power. The HVDC links are designed to operate continuously down to 70% of the rated DC voltage. The main technical data are given in the table.

### Power circuit arrangement

The main circuit arrangement of the two links **5** is identical except for the reactive power compensation equip-



Main parameters	3GC (3GG)
Nominal power rating, MW	3000
Nominal dc voltage, kV	±500
Transmission distance, km	890 (940)
Power overloads at max ambient temperatures with redundant cooling in service, MW:	
Continuous	3150
2 hour	3390
10 seconds	4230
5 seconds	4500
Converter transformers:	
Type	1-phase, 2-winding
Power rating, MVA	297.5/283.7
Smoothing reactors:	
Type	Oil-insulated
Value, mH	290/270 (290)
Thyristor type	YST-90
DC filter type	Passive
AC filter type	Passive
AC system voltage, kV	525/500
AC system frequency, Hz	50

ment. Stable steady-state and dynamic operation of the AC-DC systems is ensured by optimizing use of the reactive power capacity of the generators in the Three Gorges power plant and the AC networks at each end of the links. One-and-a-half breaker configurations are used on the AC side at both stations.

The links have been designed for a rating of 2x1500 MW, a continuous overload capability of 3480 MW, and a 5-second overload capability of 4500 MW.

In addition to the bipolar transmission scheme, the links can be connected for monopolar transmission with either a ground or metallic return. The main circuit connection on the DC side is typical for an HVDC bipole with over-

head transmission line. Metallic return transfer breakers and ground return transfer switches have been installed to meet the requirements of monopolar metallic return operation, and provide capability for uninterrupted transfer. Neutral bus grounding switches are also installed at the neutral buses of both stations to meet temporary grounding requirements.

### Thyristor valves

A double valve scheme **6** was chosen to take account of the converter transformers being single-phase, two-winding units. Longquan and Jingzhou converter stations have 90 thyristors (3 kA, 7.2 kV) per valve, while at the receiving stations Zhengping and Huizhou each valve has 84 thyristors (same rating). Dry-type damping capacitors and film DC resistors are used. Comprehensive fire detection and protection is incorporated in the valve hall design.

### AC filtering

Four types of filter are used: double tuned 11th and 13th, double tuned 24th

and 36th, double tuned 12th and 24th, and C-type 3rd harmonic. Shunt capacitor banks, with and without damping reactors, balance the reactive power requirement at Jingzhou, Zhengping and Huizhou converter stations.

**DC filtering**

Robust passive DC filtering ensures a performance level of 500 mAp (bi-pole)/1000 mAp (monopole) for both projects. Each terminal pole has two filter arms designed as double tuned filters, one tuned to the 12th and 24th harmonics and the other to the 12th and 36th harmonics.

**Control and protection**

The projects' control and protection strategies are realized with ABB's state-of-the-art MACH2 system. MACH2 features high-level performance, low maintenance, a very powerful programming environment and good integration with SCADA systems. The SCADA systems enable information about the operating status of each converter station to be accessed remotely by dis-



Power will be transmitted eastward during the peak generation period and toward the central power grid whenever reservoir water needs to be conserved.

patch centers. These centers have full remote control capability and can regulate power transmission on the link. Terminal-to-terminal communication is via optical fiber ground wire. Capacity not needed for communication is used for dispatch and for data transfer on the networks, but could also be used for commercial purposes.

Control functions such as power ramping, frequency control and damping modulation, are also integrated. The station engineer can adjust the interface and parameters as required by the system.

**Converter transformers and smoothing reactors**

The single-phase converter transformers 7 in the Longquan and Jingzhou stations are rated 297.5 MVA,  $525/\sqrt{3}:210.4/\sqrt{3}$  (210.4 for Y-D) kV, 16% reactance, with an OLTC tap range of +25/-5 (1.25% per step). The Zhengping transformers are rated 283.7 MVA,  $500/\sqrt{3}:200.4/\sqrt{3}$  (200.4 for Y-D) kV, 16% reactance. Here, the OLTC tap range is +26/-2. In the Huizhou station the transformers are rated 283.7 MVA,  $525/\sqrt{3}:200.6/\sqrt{3}$  (200.6 for Y-D) kV, 16% reactance, also with an OLTC tap range of +28/-4 (1.193% per step). Dry-type bushings are used for the valve hall penetration. The converter transformers at Longquan, Jingzhou and Huizhou are also equipped with electronic control, allowing analysis and reporting, plus intelligent fan control to minimize losses.

The smoothing reactors are connected to the valves via the bushing penetrating the valve hall wall. An electronic control system for the reactors at Longquan, Jingzhou and Huizhou features the same capability as that provided for the transformers.

7 Converter transformer arrangement per pole



## Power take-off

Electric power generation in China tends to be located in the northeast (coal-fired), and in the west and southwest (hydropower), while the main consumer areas are in the eastern coastal area and southern industrial region of Guangdong.

China's total generating capacity of more than 350,000 MW (end of 2002) needs to grow to at least 500,000 MW by the end of the decade to cope with increased demand. Due to its fast-growing economy, many areas, including Shanghai, Guangdong and Zhejiang provinces, are already today suffering from a significant power supply shortfall. Guangdong province, for example, has a deficit of over 30,000 MW, some of which is met through imports from neighboring Hong Kong.

China now plans to start adding 25,000 to 30,000 MW each year through 2005, for an annual growth of 7% to 8%. Both AC and DC transmission are foreseen for the extensions. Over the next ten years, the HVDC market – long-distance transmissions and back-to-back stations to interconnect the regional networks – is estimated at 40,000 MW.

### DC-side breakers and switches

SF<sub>6</sub> breakers are used for all the high-speed DC switches: metallic return transfer breakers, neutral bus grounding switches, neutral bus switches and ground return transfer switches. The ground return transfer switch is the only one of these to be of conventional passive design. All the others have an active auxiliary transfer circuit consist-

ing of a capacitor and a charger. The charger gives the DC switches extra current commutation capability, enabling them to handle even the highest overload currents.

### Operating configurations

The links can be operated in many different configurations and modes. Emergency operation is provided for, as is

operation without telecommunication. Through accurate measurement and control it is ensured that in the case of bipolar balanced operation with local station ground the unbalance current to ground will be zero.

The operating modes are:

- Bipolar
- Monopolar earth return and metallic return
- Reduced DC voltage (from 500 kV to 350 kV)
- Reverse power operation
- Bipole and pole power control
- Pole synchronous and emergency (separate) power control
- Pole backup synchronous control (for modulation of DC current without inter-station telecommunication)
- Pole current control

### Meeting China's energy demand

China plans to substantially expand its generating capacity by 2010 in order to cope with the predicted growth in demand (see panel). At the same time, two new regional networks will be created as the basis for a new national transmission grid. HVDC, with all its advantages for long-distance transmission, is expected to play a major role in the extensions.

### “A remarkable achievement in the history of ABB's HVDC technology”

The inauguration of the Three Gorges – Changzhou HVDC link in August 2003 in the presence of representatives of the Chinese government, State Council Three Gorges Office, State Power Grid Corporation and ABB, marked the successful completion of trials and the start-up of commercial operation. The 500-kV, 890-kilometer long HVDC link can operate at world record levels of up to 3,480 megawatts, and when the Three Gorges generators begin operating later this year it will transmit electricity to millions of consumers in eastern China. The largest and longest bipole DC power transmission link in China was completed on schedule in four years.

“Considering the project's technical complexity, this is a remarkable achievement in the history of ABB's HVDC technology,” says Peter Smits, head of ABB's Power Technologies division. “By delivering this challenging project on time almost to the day, we have demonstrated our commitment to speed and precision, and to improving the quality of life for millions of Chinese citizens.”

**Leif Englund**  
**Mats Lagerkvist**  
**Rebati Dass**

ABB Power Technologies  
SE-771 80 Ludvika  
Sweden  
leif.englund@se.abb.com  
mats.lagerkvist@se.abb.com  
rebati.dass@se.abb.com

## References

- [1] Introduction to China's Yangtze River Three Gorges Project. The PRC State Council Three Gorges Construction Committee, Ministry of Land and Resources, State Environmental Pollution Administration, State Bureau of Cultural Relics, September, 2002.
- [2] Z. Xiaoqian, D. Gongyang, G. Ricai: The Three Gorges power grid and its development. Cigré 1998, 37–203, Paris.
- [3] Z. Xiaoqian, et al: Design Features of the Three Gorges – Changzhou ±500 kV HVDC Project. Cigré 2000, 14–206, Paris.

# FACTS

## Improving the performance of electrical grids

Rolf Grünbaum, Åke Petersson, Björn Thorvaldsson



After years of underinvestment in their transmission infrastructure, power utilities are being forced to look at ways of utilizing their existing transmission lines more efficiently, at possibilities for cross-border cooperation, and at the issue of power quality. This situation has dramatically increased interest in new as well as traditional solutions.

FACTS (Flexible AC Transmission Systems), such as SVC, SVC Light<sup>®</sup>, TCSC and others, are just such solutions. They take advantage of the considerable technical progress made in the last decade and represent the latest state of the art. While a typical application would be to increase the capacity of any given transmission line, this article describes some special cases with unique requirements and how they were met.

If prestigious projects were ever needed to demonstrate FACTS' credentials as an improver of T&D performance, none could serve better than the Dafang 500-kV series capacitors helping to safeguard Beijing's power supply, the Eagle Pass back-to-back tie straddling the US/Mexican border, or the Channel

Tunnel rail link. These, in their different ways, show why FACTS is arousing so much interest in the electrical supply industry today.

### **Dafang: series capacitors safeguard the Beijing area power supply**

Power demand in the area served by the

North China Power Network, with 140 million people and including Beijing, is growing at a steady pace. Installing new generation plant and transmission lines is nearly impossible due to urban growth. An attractive alternative is to insert series capacitors in the existing transmission corridor to provide series compensation.



ABB was contracted to do this, and installed two series capacitors (each rated 372 MVar, 500 kV) in the middle of each line of a 300-km twin-circuit corridor between Datong and Fangshan **1**. They came on stream in June, 2001, a mere nine months after the contract was awarded and some 3 to 6 months faster than for similar installations.

A series capacitor acts to reduce the transfer reactance of the power line at power frequency (50 Hz) and supplies reactive power to the circuit at the same time. The benefits of this are:

- Increased angular stability. There must always be a certain difference between the voltage phase angles at either end of the power line to enable transmission. The phase angle difference increases with power transmission and the series capacitor keeps the angular difference within safe limits, ie it ensures that the angular difference does not increase so much that it could jeopardize the angular stability.

- Improved voltage stability of the corridor.
- Optimized power sharing between parallel circuits. Without series capacitors, the line with the least power transmission capacity would saturate first and no additional power could be fed into the system, despite the fact that the other line still has capacity to spare. The series capacitors redistribute power between the lines for better overall utilization of the system.

The series capacitors are fully integrated in the power system and benefit from its control, protection and supervisory capability. They are fully insulated to ground.

The main protective devices used are ZnO varistors and circuit-breakers. The first is to limit the voltage across the capacitor and is supplemented by a forced-triggered spark gap to handle excess current during a fault sequence. The circuit-breakers connect and dis-

connect the series capacitors as required. They are also needed to extinguish the spark gap, as it is not self-extinguishing.

The capacitors are rated for operation during normal, steady-state grid conditions as well as for severe system contingencies, such as loss of one of the two parallel 500-kV lines. In such a case, the capacitor of the line remaining in service must be able to take the full load of both lines for a certain amount of time. This was, in fact, one of the reasons for installing the series capacitors in the first place – to ensure the safe transfer of power to the Beijing area even with a line down.

**Eagle Pass Back-to-Back (BtB) Light SVC Light technology<sup>1)</sup>** has successfully solved power quality problems in several projects undertaken by ABB. Based on a common platform of voltage source converters (VSC), SVC Light also provides solutions for power conditioning applications in transmission systems. The Eagle Pass tie is a good example of a project in which the VSC platform is configured as back-to-back HVDC, although functionally with priority given to voltage support with the dual SVC Light systems.

Most important in this respect is the fact that installation of active power transfer capability, using HVDC Light across a certain distance or in a back-to-back configuration, will provide both bidirectional active power and dynamic reactive power support simultaneously. Thus, strong voltage support is readily available along with the steady-state power transfer.

The Eagle Pass substation (operated by American Electric Power, AEP) is located in a remote part of Texas, on the Mexican border, and is connected to the Texas transmission system through two 138-kV transmission lines. The nearest significant generating station is located

<sup>1)</sup>SVC Light is a product name for an IGBT-based static synchronous compensator from ABB.

145 km away and provides very little voltage support to the Eagle Pass area. Eagle Pass also has a 138-kV transmission line that ties into Piedras Negras substation (operated by Commission Federal Electricas, CFE) on the Mexican side. This is used mainly in emergencies to transfer load between power systems, but such transfers involve interrupting the power as the CFE and AEP systems are asynchronous (despite both being 60 Hz). To overcome this disadvantage, and also solve problems arising from increasing demand, a better solution was sought.

**ABB's response:  
voltage source converters**

Load flow studies demonstrated that the installation of a 36-MVA voltage source converter directly at the Eagle Pass substation would provide years of respite. Installation of a VSC is ideal for weak systems as the alternative, reactive support provided by shunt capacitors, decreases rapidly when the voltage is reduced. Extending the scenario, two VSCs connected back-to-back would not only supply the necessary reactive power but also allow active power transfer between the two power systems. A BtB scheme would enable the 138-kV line between Eagle Pass and Piedras Negras to be continuously energized and allow the instantaneous transfer of active power from either system.

Having the capability to control dynamically and simultaneously both active and reactive power is unprecedented for BtB interconnections. This feature is an inherent characteristic of the VSC.

As commutation is driven by its internal circuits, a VSC does not rely on the connected AC system for its operation. Full control flexibility is achieved by using pulse width modulation (PWM) to control the IGBT-based bridges. Furthermore, PWM provides unrestricted control of both positive- and negative-sequence voltages. Such control ensures reliable operation of the BtB tie even when the connected AC systems are unbalanced. In addition, the tie can energize, supply and support an isolated load. In the case of Eagle Pass, this allowed the uninter-

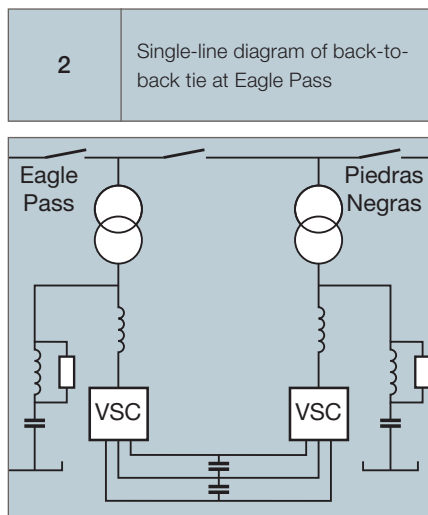

rupted supply of power to local loads even if connections to one of the surrounding networks were tripped. Both sides of the tie can also be energized from 'across the border', without any switching that could involve interruptions of supply to consumers.

**The back-to-back installation**

A simplified one-line diagram of the BtB tie in Eagle Pass is shown in 2.

The BtB scheme consists of two 36-MVA VSCs coupled to a common DC capacitor bus. The VSCs are of the NPC (neutral point clamped) type, also known as three-level converters. Each VSC is connected to a three-phase set of phase reactors, each connected to a conventional step-up transformer on its respective side of the BtB. The layout of the BtB installation is shown in 3.

**BtB operating modes**

The two VSCs of the BtB can be configured for a wide range of different functions. At Eagle Pass, the main BtB operating configurations are as follows:

- Voltage control
- Active power control
- Independent operation of the two VSCs
- Contingency operation of the BtB

**Voltage control**

In this mode, both the AEP and CFE systems are capable of independent voltage control. The BtB provides the required reactive power support on both sides to maintain a pre-set voltage. Active power can be transferred from

<b>3</b>	Eagle Pass back-to-back tie Foreground: 138-kV equipment and harmonic filters. Middle: buildings with converters, controls and auxiliaries. Back: cooling towers for water-cooled IGBT converters
----------	--



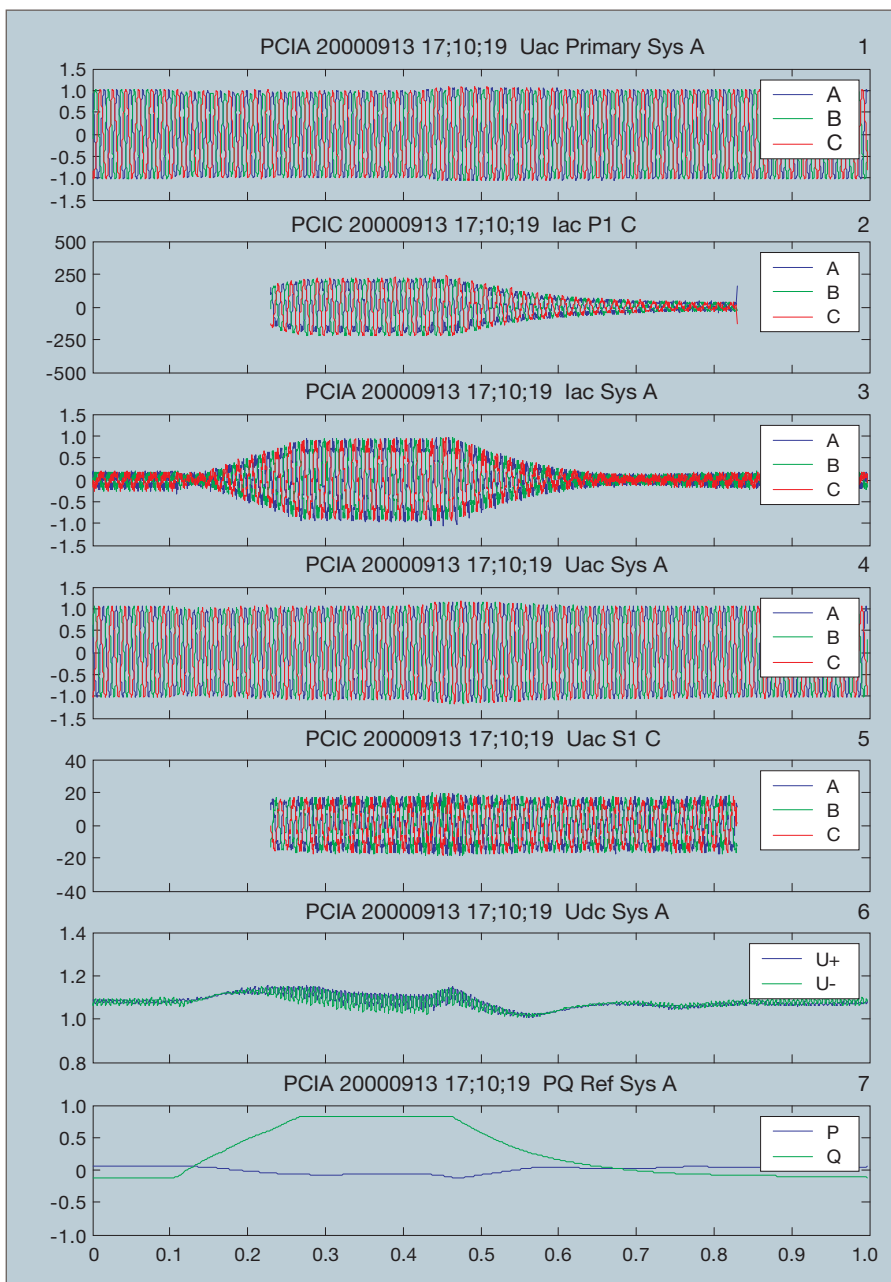

- |   |  |
|---|--|
| 1 AEP 138-kV voltages                                   | 5 AEP 17.9-kV phase-to-ground voltages, in kV                |
| 2 AEP step-down transformer secondary currents, in amps | 6 DC voltages  |
| 3 AEP phase reactor currents                            | 7 AEP converter, active (P) and reactive power (Q) reference |
| 4 AEP 17.9-kV voltages                                  |  |

either side while a constant system voltage is maintained on both. Any active power transfers that are scheduled are automatically and instantaneously lowered, if required, by the control system

to supply the reactive power needed to maintain a constant voltage.

#### Active power control

In this mode, active power can be trans-

ferred between the AEP and CFE systems. Power transfer is allowed when the voltage is within a dead-band. If the voltage lies outside it, the BtB automatically reverts to voltage control mode. The active power flow is then automatically and instantaneously lowered by the BtB to provide the required reactive power support. The dead-band is designed so that local capacitor switching or changes in remote generation that cause slight voltage swings do not cause the BtB to switch to the voltage control mode.

#### Independent operation of the two VSCs

Should maintenance be required on one side of the BtB, the other side is still able to provide voltage control to either side of the tie. This is done by opening the DC bus, splitting it into two halves. As the DC link is open, no active power can be transferred between the two sides of the BtB. Each VSC will then be capable of providing up to  $\pm 36$  MVar of reactive support to either side.

#### Contingency operation of the BtB

If one of the 138-kV lines into the Eagle Pass substation is lost, the remaining 138-kV line can only support 50 MW of load at the substation. Should this occur, the voltage falls below 0.98 pu and the BtB switches to the voltage control mode. Active power is reduced automatically and instantaneously to make sure the 50-MW load level at the substation (AEP load plus the export to CFE) is not violated. The BtB supplies the required reactive support to maintain a 1-pu voltage. Load flow studies have shown that the transmission line contingency on the AEP side will have little impact on the power transfers from AEP to CFE.

#### Dynamic performance

The recording reproduced in 4 illustrates well the highly dynamic performance of the BtB Light installation at Eagle Pass. Plots 1–7 show how the BtB responded to lightning conditions in a remote area that caused a voltage dip in the AEP network. During the fault, the BtB current (capacitive) was increased to almost 1 pu to support the bus voltage at Eagle Pass.



### Channel Tunnel rail link

When the high-speed electrified railway line between London and the Channel Tunnel to France is finished in 2007 it will be possible to travel between London and Paris in just over two hours, at a maximum speed of 300 km/h. The railway power system is designed for power ratings in the range of 10 MW and which fluctuate (rapid acceleration and retardation). The traction feeding system that was supplied by ABB is a modern 50-Hz, 2 × 25-kV supply incorporating an autotransformer scheme to keep the voltage drop along the traction lines low. Power step-down from the grid is direct, via transformers connected between two phases **5**.

**5** Power feeding system for the Channel Tunnel rail link between England and France. Singlewell substation with two single-phase static var compensators, each rated 25 kV, -5/+40 MVar

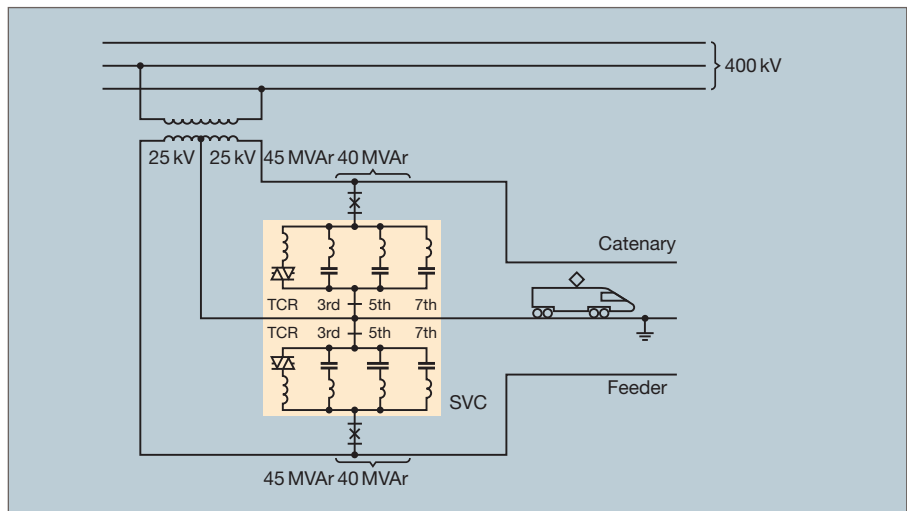

### SVCs for the three traction feeding points

A major feature of this power system is the static VAR compensator (SVC) support, the primary purpose of which is to balance the unsymmetrical load and to support the railway voltage in the case of a feeder station trip – when two sections have to be fed from one station. The second purpose of the SVCs is to ensure a low tariff for the active power by maintaining unity power factor during normal operation.

Thirdly, the SVCs mitigate harmonic pollution by filtering out the harmonics from the traction load. This is important as strict limits apply to the traction system's contribution to the harmonic level at the supergrid connection points.

The SVCs for *voltage support* only are connected on the traction side of the interconnecting power transformers. The

supergrid transformers for the traction supply have two series-connected medium-voltage windings, each with its midpoint grounded. This results in two voltages, 180 degrees apart, between the winding terminals and ground. The SVCs are connected across these windings; consequently, there are identical single-phase SVCs connected feeder to ground and catenary to ground.

The traction load of up to 120 MW is connected between two phases. Without compensation, this would result in an approximately 2% negative phase sequence voltage. To counteract the unbalanced load, a *load balancer* (an asymmetrically controlled SVC) has been installed in the Sellindge substation. This has a three-phase connection to the grid.

The load balancer transfers active power between the phases in order to create a balanced load (as seen by the supergrid). A brief explanation of how the load balancing works is given in the following.

### Load current

When the load is connected between two phases (B & C) only, the traction current can be expressed by two phase vectors, one representing the positive sequence and the other the negative sequence **6**. The summation of the two vectors is the resulting current (current in phase A is zero and currents in phase B and C are of equal magnitude, but of opposite phase). Note that the vector amplitudes are not truly representative. To compensate the negative sequence and thus balance the current to be gen-

**6** Phase-sequence components of the load current

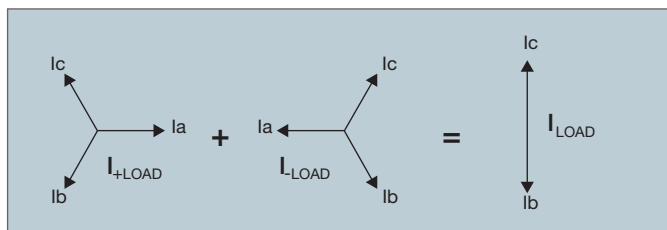

**7** Load current balancing

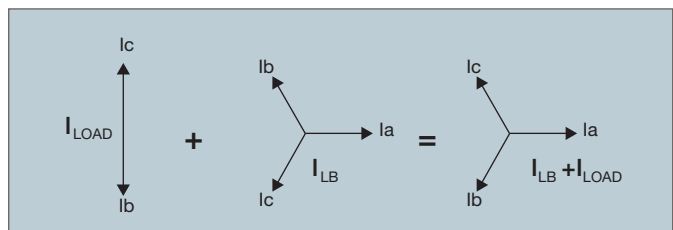

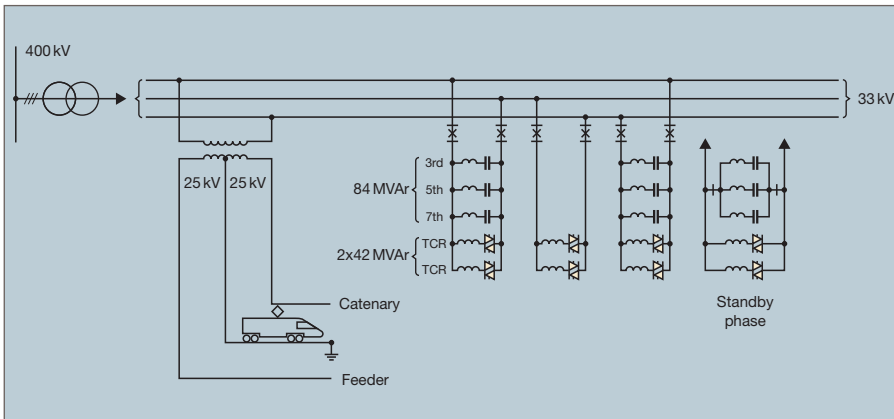

erated by the power systems, the load balancer generates a (pure) negative-phase sequence current, ( $I_{LB}$ ), as shown in 7. This current balances exactly the negative-phase sequence current from the load ( $I_{LOAD}$  in 6).

The load balancer in the Sellindge substation 8 is optimized to handle a load connected between the C and A phases. Load balancing theory says that, to balance a purely active load, a capacitor has to be connected between phases A and B and a reactor between phases B and C. The traction load also has a reactive part, which likewise has to be balanced. In this substation, not only the asymmetry is compensated but also the power factor. This is achieved by inserting a capacitor between phases C and A.

#### Redundancy

High availability is required, so all critical components are redundant: A complete fourth redundant phase has been added in the main circuit. All the phases need to be as independent of each other as possible.

These requirements have resulted in a unique plant layout and design for the control and protection. There are four fully independent 'interphases' (an assembly of components connected between two phases). Each interphase features an independent set of filters, reactors, thyristor valves, thyristor firing

logic circuits, measuring transformers, relay protection devices and cooling system. Each of the connections to the substation busbars has a circuit-breaker and disconnector inserted in it. Filters can be connected to or disconnected from the fourth interphase to turn it into either an inductive or a capacitive branch.

Two independent control systems act on the three-phase system, while the thyristor firing and logic circuits act directly on each interphase. The control systems are strictly segregated, as are the valve-firing logic circuits and the overall protection system. If an interphase fails, the control system trips it and automatically substitutes the standby unit.

The thyristor valves make use of a new type of thyristor – a bidirectional device with two antiparallel thyristors on a common silicon wafer. This halves the number of units needed in the valves. The thyristor is a 5-inch device with a current-handling capability of about 2000 A(rms).

#### Summary and outlook

The importance of improving grid performance is growing for economical as well as environmental reasons. FACTS devices have established themselves as the most suitable solutions for increasing power transmission capability and stability.

The Dafang project is a classic example of a transmission capacity upgrade providing much-needed power to a fast-growing area, in this case the region around Beijing. The project was completed in the extremely short time of nine months and brings existing, remotely generated power to an area where it is urgently needed.

The case of Eagle Pass shows the possibilities offered by new technologies able to combine advanced FACTS properties with network interconnection capability. The latest developments in semiconductor and control technology have made this possible. Thanks to this back-to-back tie, existing transmission facilities can be utilized to a much greater extent than before.

Finally, the Channel Tunnel rail link illustrates well the flexibility of FACTS devices by showing how they can also be used to solve the problems created by new, sophisticated types of load. The unbalance caused by new traction loads, for example, can be mitigated, and downgrading of the electricity supply for other users avoided, by means of the described solid-state solutions.

These examples show that FACTS devices will be used on a much wider scale in the future as grid performance becomes an even more important factor. Having better grid controllability will allow utilities to reduce investment in the transmission lines themselves. ABB is currently exploring ways in which FACTS devices can be combined with real-time information and information technologies in order to move them even closer to their physical limits.

Rolf Grünbaum

Åke Petersson

Björn Thorvaldsson

ABB Power Technologies

SE-721 64 Västerås

Sweden

rolf.grunbaum@se.abb.com

# Power

ABB static var compensator stabilizes Namibian grid voltage |

Rolf Grünbaum, Mikael Halonen, Staffan Rudin

# factor!



The spectacular dune landscapes of Namibia are a key factor in the country's booming tourist industry and a valuable source of revenue for the nation. Another, even more important pillar of the Namibian economy is the power-hungry mining industry. To cope with growing energy demand in these two sectors and to ensure a reliable power supply for the country as a whole, NamPower, Namibia's national electricity utility, has installed a new 400-kV AC transmission system linking its grid system with the Eskom grid in South Africa. Voltage stability problems, which the new line would have aggravated, have been resolved by installing a static var compensator from ABB.

While construction of the new line has brought reliable power to Namibia, it was not without problems of its own. The line's length of 890 km, for instance, aggravated certain problems – mainly voltage instability and near 50-Hz resonance – that already existed in the NamPower system.

An ABB static var compensator (SVC) rated from 250 MVar inductive to 80 MVar capacitive has been installed to solve these problems. The turnkey project was concluded with the successful commissioning of the SVC in NamPower's Auas 400-kV substation 1, just 18 months after the contract was signed.

### The case for a new 400-kV grid

Power consumption in Namibia is concentrated in Windhoek and in the northern region, where most of the mining and mineral industry is located. Until recently, the NamPower grid consisted of a radial network, with bulk power supplied by the Ruacana hydro-station in the north via a 520-km 330-kV transmission circuit, linked by an 1000-km 220-kV interconnection to Eskom's system in the south.

This network was often loaded to its stability limits during low-load periods

1 Auas static var compensator



when Ruacana was not providing power. The system is also unique for its long 220-kV and 330-kV lines and the fact that the loads are small in comparison with the generation sources – two features that further aggravated the stability problems in low-load conditions.

To solve these problems, the utility decided to build a 400-kV grid. The final phase of construction – a 400-kV interconnection between Auas and Kokerboom 2 – was completed in 2000. This single-circuit 400-kV AC transmission line strengthens the NamPower system by connecting it to Eskom's system in

2 NamPower network



3 System impedance/frequency characteristics (a) and system near 50-Hz resonance (b)

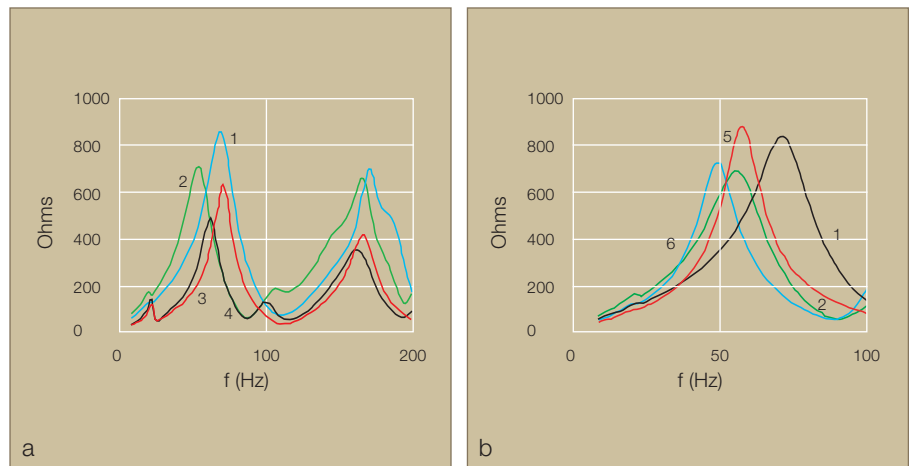

- 1, 2 Existing system, with four and no generators
- 3, 4 New system, with four and no generators
- 5, 6 During 400-kV energization, with four and no generators

the south. However, with a length of 890 km it is also very long, in fact one of the longest lines of its kind in the world. This and the network's tree-like configuration, coupled with remote generation and the very long radial lines operated at high voltage, results in the charging capacitance being high. The effect of this is to shift the existing parallel resonance closer to 50 Hz, making the network more voltage-sensitive during system transients, for example when the 400-kV line is energized or during recovery after a line fault clearance. Each of these phenomena manifests itself as an extremely high and sustained overvoltage.

### Resonance and overvoltages

The NamPower network has a first natural parallel resonance frequency well below 100 Hz, namely in the 55–70 Hz range (curves 1 and 2 in 3).

The effect of adding the new 400-kV line section (Aries-Kokerboom-Auas) and its four 100-MVAr shunt terminal reactors has been to shift the system's first resonance into the 60–75 Hz frequency range (curves 3 and 4). (The reduction in system impedance at 50 Hz is due to the new 400-kV line,

and an indication of how the system has been strengthened.)

Curves 5 and 6 in 3 show the network impedance as seen at the Auas 400-kV bus the instant the 400-kV line is energized from the northern section (from the Auas side) and before the circuit-breaker on the Kokerboom side is closed.

The impact of the resonance problem in the NamPower system is best illustrated by simulating the condition at Auas substation, represented by curve 6. The voltage situation is shown in 4, in which the line circuit-breaker at Auas is closed at time  $t = 1.0$  s and it is assumed that the breaker at Kokerboom is synchronized at  $t = 1.2$  s. Due to the large charging capacitance of the line the voltage first dips, then overshoots.

The extremely high overvoltages appearing at Auas, with a peak value in excess of 1.7 pu and a sustained transient overvoltage (TOV) of more than 1.5 pu, attest to the severity of the problem. It is clear that as soon as 50-Hz resonance is triggered very high dynamic overvoltages appear with large time constants under certain system load and generation conditions.

5 Single-line diagram of the Auas SVC

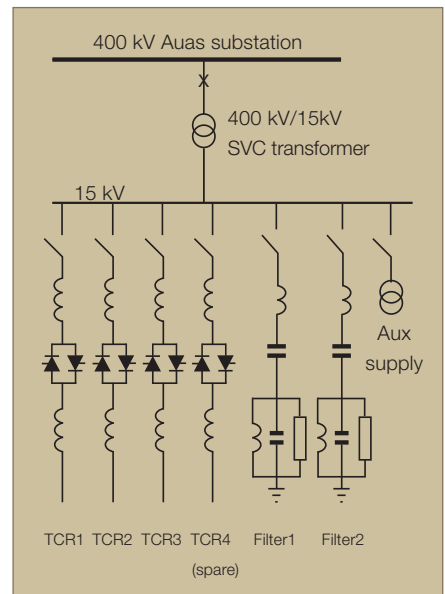

80 MVar capacitive) and is installed primarily to control the system voltage, in particular the extreme (up to 1.7 pu) overvoltages expected as a result of the near 50-Hz resonance. An uncommon feature of the project is that the SVC is installed in a system with very long lines, little local generation and fault levels lower than 300 MVA.

The SVC that is installed is of a new type, developed by ABB for power applications. Its unique control principle has since been patented. The inductive

power of 250 MVar is provided by three thyristor-controlled reactors (TCRs), a fourth, continuously energized TCR being always on standby 5. Two identical double-tuned filters, each rated at 40 MVar, take care of harmonics and supply capacitive reactive power during steady-state operation.

High availability is essential for the Auas SVC. If, for any reason, it should have

4 Energization of the Auas-Kokerboom 400-kV line from the northern section, without the SVC

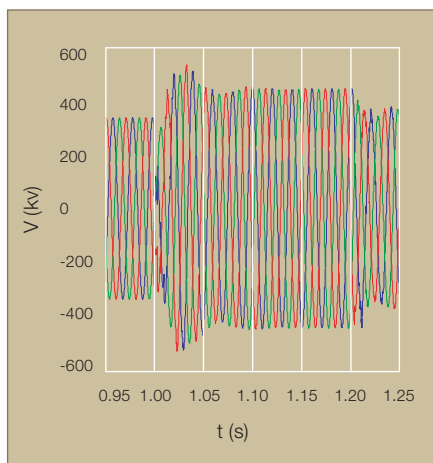

The blue, green and red curves represent the different phases (instantaneous values).

Preliminary studies indicated that overvoltages would appear that would make the NamPower system inoperable unless very fast, effective and reliable countermeasures are taken. Several solutions were considered as an answer to the resonance problem, including fixed and switched reactors, before deciding to install a FACTS device in the Auas substation. Preference was given to conventional, proven SVC technology [1].

### SVC design features

The Auas SVC has a dynamic range of 330 MVar (250 MVar inductive to

Studies showed that overvoltages could make the NamPower system inoperable unless very fast, effective and reliable countermeasures are taken.

6

V/I characteristic, showing the possible steady-state and transient operating points of the SVC

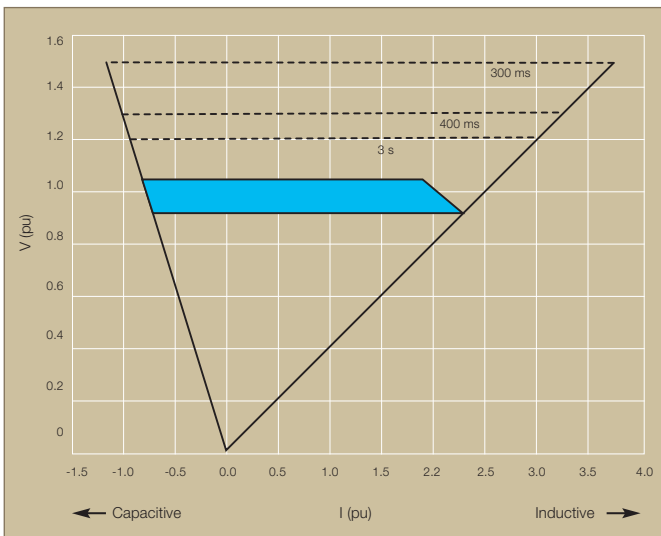

The colored area represents continuous SVC operation. Above this area, the SVC can be operated up to 1.2 pu voltage for 3 s, up to 1.3 pu voltage for 400 ms, and up to 1.5 pu voltage for 300 ms.

to be taken out of service, the 400-kV transmission system could not be operated without risking dangerous overvoltages. As a result, an availability figure of 99.7 % was specified, and this strongly influenced the design, quality, functionality and layout of its components and subsystems as well as of the SVC scheme as a whole.

#### Operating range

The Auas SVC provides resonance control over its entire operating range **6**, which extends well beyond its continuous range. Controlled operation is possible all the way up to 1.5 pu primary voltage – a necessary feature for controlling the resonance condition. Besides providing resonance control, the SVC also controls the positive-sequence voltage (symmetrical voltage control) at the point of connection.

#### Single-phase transformers

Four single-phase transformers, including one spare, are installed. Due to the high overvoltage demands made on them during resonance these transformers have been designed with a lower flux density than standard units; they

should be the last transformers in the Nam-Power system to go into saturation.

#### TCR reactor

and valve  
Each TCR branch consists of two air-core reactors connected on each side of a thyristor valve. The reactors have special exterior surfaces to protect them from the effect of sand storms and sun in the harsh desert environment.

tors (16 thyristors, two of which are redundant, in each valve). Snubber circuits (series-connected resistors and capacitors) limit overvoltages at turnoff. The thyristors are fired electrically using energy taken directly from the snubber circuit.

An overvoltage protection device limits the voltage that can appear across the valve, being triggered by control units that sense the instantaneous voltage across each thyristor level.

#### Redundant TCR branch

Three TCR units rated at 110 MVAR have been installed to cope with the Nam-Power network's sensitivity to reactive power and harmonic current injections. A fourth, identical TCR is kept on hot standby. The SVC control system automatically rotates the current standby TCR unit every 30 hours to ensure equal operating time for all units.

#### Redundant cooling system

An unusual feature of the Auas SVC is that each TCR valve has its own cooling system, making four in all. Thus, outage time is minimized and availability is increased. A water/glycol cooling medium is used to avoid freezing in case of aux-

A secondary voltage of 15 kV was chosen as an optimum value for both the thyristor valve and busbar design. The thyristor valves consist of single-phase stacks of antiparallel-connected thyris-



iliary power outages during the cold desert nights.

**Filter branches**

The required capacitive MVar are provided by two 40-MVar filter banks. Each filter is double-tuned to the 3rd/5th harmonics and connected in an ungrounded configuration. The double-tuned design was chosen to ensure sufficient filtering even in the case of one filter becoming defective.

**Black-start performance**

Since the SVC is vital for operation of the NamPower system, everything has to be done to avoid the SVC breaker tripping, even during a network black-



7 Real-time digital simulation. 400-kV line energized from the north, with and without the new resonance controller

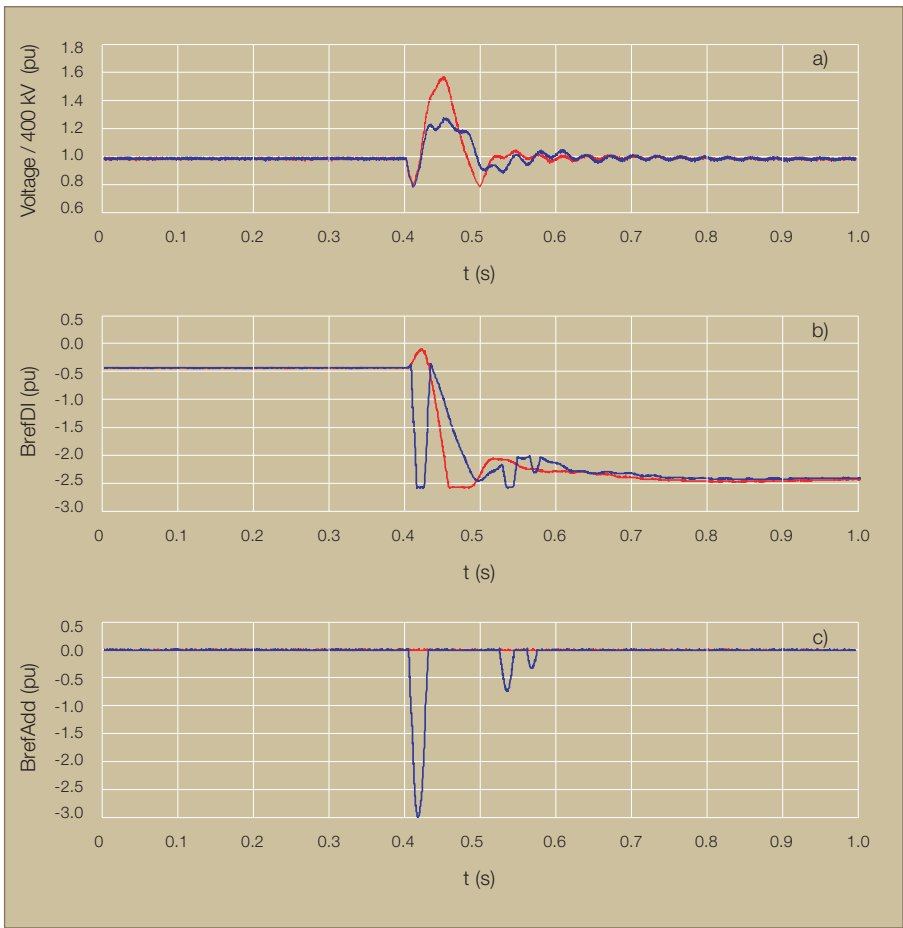

a Voltage response, 400 kV  
 b SVC controller output  
 c Impact of resonance controller  
 Red Conventional PI controller  
 Blue Resonance controller

out. In such a case the network could be energized from the Eskom side and the SVC would have to be immediately ready to control a possible resonance condition. To handle this task, the SVC has three separate auxiliary supplies, one of which is fed directly from the SVC secondary bus. The SVC is capable of standby operation with its MACH 2 controller active for several hours without auxiliary power, and automatically goes into resonance control mode as soon as the primary voltage returns.

**Worst-case situation: energization from north to south**

The worst-case scenario for the SVC and the Nampower system is energization of the 400-kV line from the northern section (Auas substation). This system condition, which initiates the critical 50-Hz resonance, was therefore simulated in a real-time digital simulator with and without the new resonance controller. As shown in 7 the overvoltage that appears at Auas is 1.62 pu with a conventional PI controller. (The two resonance frequencies – 56 Hz and 81 Hz – that can be seen in the result correspond to the system’s first and second pole, respectively.) The new resonance controller has a considerable impact on the system’s behavior and the voltage controller’s additional contribution forces the SVC to become inductive. As a result, the peak voltage appearing at Auas is reduced to a value of 1.32 pu.

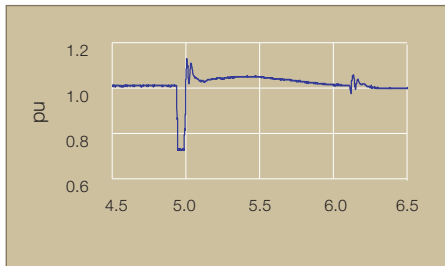

Voltage response, 400 kV

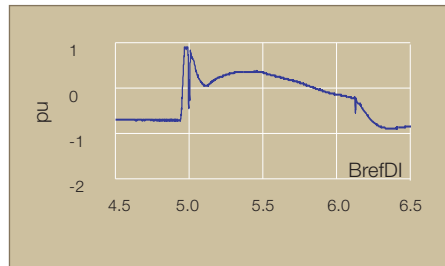

SVC controller output

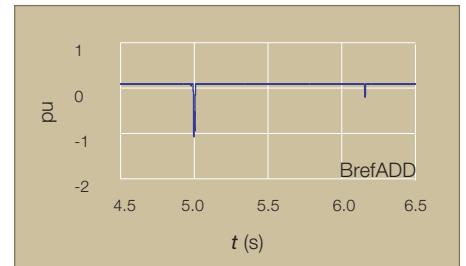

Impact of resonance controller

This extreme test was also performed in the field. Comparison of the simulation results and the system performance test shows very good agreement and underlines the improvement capability of the new resonance controller under resonance conditions.

#### Staged fault test

After the Auas substation had been commissioned, a phase-to-ground fault was used to test various SVC control

functions and the interconnection protection scheme. The performance of the SVC is shown in 8. As the results

As a result of installing the ABB SVC, the resonance problems that had previously plagued the Namibian grid are a thing of the past.

show, the SVC controls the voltage and the resonance controller forces the SVC to become fully inductive in resonance conditions. The fault is initiated at  $t = 4.9$  s and is cleared by opening the faulty phase in the Auas-Kokerboom line. A single-phase auto-reclosure is initiated after 1.2 s, starting with the breaker on the Kokerboom side.

The overvoltage at Auas is reduced to 1.14 pu.

#### Easier cross-border power sharing

As a result of installing the ABB SVC, the resonance problems that had previously plagued the Namibian grid are a thing of the past. Southern Africa's state energy sectors can now be more easily integrated and power more easily shared. And the growing demand for power – the motor driving the region's economic ambitions – can be more easily met.



Rolf Grünbaum

Mikael Halonen

Staffan Rudin

ABB Power Technologies

SE-721 64 Västerås

Sweden

Fax: +46 21 18 31 43

rolf.grunbaum@se.abb.com

#### References

[1] R. Grünbaum, M. Noroozian, B. Thorvaldsson: FACTS – powerful systems for flexible power transmission. ABB Review, 5/1999.



# Transforming transforming

## Advanced transformer control and monitoring with TEC

Lars Jonsson



Getting the most out of electrical equipment is vital to energy enterprises in today's increasingly deregulated world. With power transformers making up a substantial part of that equipment, it is little wonder that utilities put a premium on enhancing the lifetime and performance of these industry workhorses.

Conventional control and monitoring schemes rely on past results – good enough, perhaps, for routine maintenance and non-critical units, but not to keep transformers performing constantly, and unfailingly, at the highest level. Not so ABB's TrafoStar Electronic Control (TEC) system. This models the actual state of the transformer, creating a 'virtual copy' that provides the parameters required to optimize cooling as well as the data utilities need for condition-based maintenance.

Power transformers at critical nodes in electricity networks lead stressful lives. Reliability is everything. Load peaks – predictable as well as unexpected – generate high temperatures, which shorten component lifetime. In the worst case sudden failure can occur, causing havoc in the network. It is because of

this risk, and the penalties that can attach to it, that utilities give such a high priority to controlling and monitoring the status and condition of their transformers. This lets them intervene *before* failure or malfunctioning can occur. Increasingly, for many utilities, the watchword is 'early detection of failure conditions'.

### Enter the 'intelligent transformer'

Deregulation of the energy markets has brought about a paradigm shift and focused attention on, among other things, asset management and remaining life management. As a result, an increasing number of power transformers around the world are being equip-

1

TEC receives the information it needs for transformer control from just a few multi-purpose sensors.

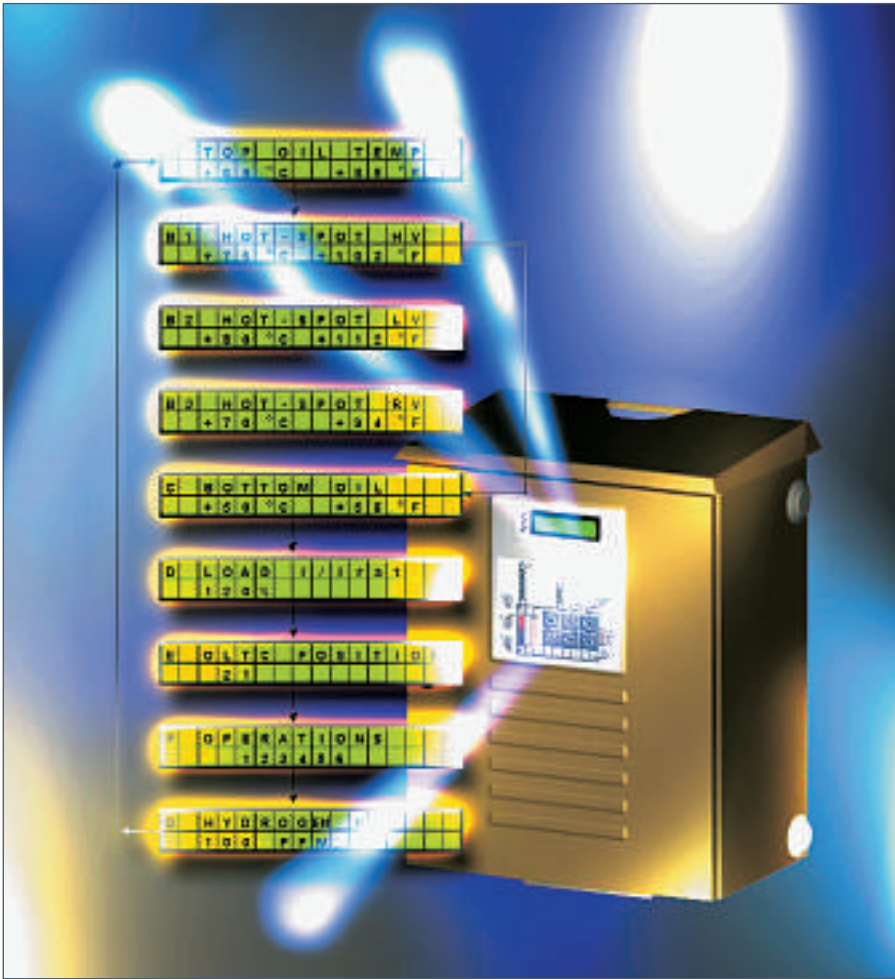

ped with monitoring devices. As this trend intensifies and more and more functionality is added, transformers are likely to play a new role – as ‘intelligent units’ – in future transmission networks.

The trouble with many transformer monitoring systems is that they are not able to control or make decisions and recommendations based on the available data, forcing engineers to spend a lot of time sorting and interpreting the information they receive. This is the strength of TrafoStar Electronic Control (TEC) **1**. TEC receives all the information it needs for transformer control from just a few multi-purpose sensors; other necessary parameters are calculated. Thus, TEC adds only minimal complexity to the transformer.

To achieve the goal of making power transformers ‘intelligent’ and maintenance-free, ABB created and integrated a common electronic interface that exchanges information with the following apparatus:

- Monitoring and diagnostics devices of the transformer and components
- Transformer control cabinet
- Tap-changer motor-drive
- Overall protection system

Through this interface, TEC provides exact status information to enable utilities to extend transformer lifetime and save costs by reducing maintenance and increasing availability.

It does this by generating a model of the transformer and its working condi-

tion and then comparing the measured parameters with the simulated values. Discrepancies are detected and potential malfunctions and/or normal wear in the transformer and its ancillaries are indicated.

As ABB’s fully integrated control and monitoring solution making use of one original set of multi-purpose sensors and employing specific transformer design data, TEC is the latest addition to a product portfolio that already includes the ABB T-Monitor. The T-Monitor is a proven retrofit solution that provides adequate predictive power by means of easily fitted add-on sensors and models that require less detailed information about the transformer and its component design.

### TEC architecture

The system hardware and software features proven ABB technology and has been designed to allow extra functionality to be added in the future. Being microprocessor-based, the system has more flexibility than a PLC and provides a more stable platform than a PC solution.

TEC gets its capability to control and monitor not only from its superior software, but also from the fact that it has unlimited access to all the information it requires. It knows everything

2

The main parameters can be viewed on-line on the TEC front panel or on a PC terminal.



3

Start panel showing a transformer model with basic data

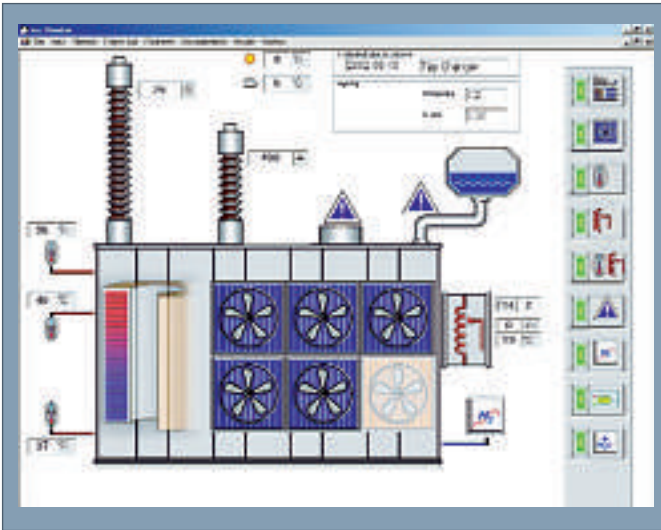

4

TEC users can easily access more detailed information as well as transformer or tap-changer documentation.

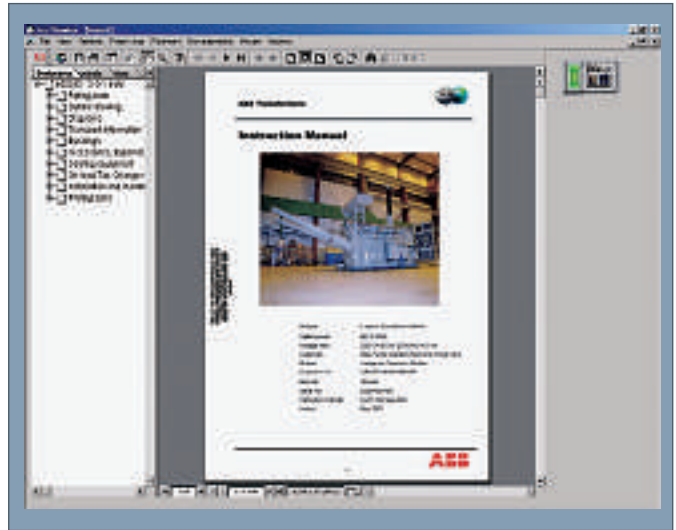

about your transformer. This 'knowledge' begins with the transformer design data. Next, temperatures and loss-related parameters obtained from the transformer heat-run test are fed in. So much data is transferred to the TEC system that it becomes a virtual transformer copy. Each transformer has its own fingerprint, with all the parameters needed for optimized control. The model created by TEC works in simulated conditions but reacts in the same way that a real transformer would.

The main parameters are processed in the TEC cabinet and transferred to the station PC via a single optic fiber. They are made available to the operator via easy-to-use software and a display.

### TEC and IndustrialIT

IndustrialIT [1] has been introduced by ABB as an architecture for seamlessly interconnecting all our Group's products, solutions and processes. More than that, it allows our customers, service partners and third parties to connect with them too. Industrial IT enables the total integration of business processes with real-time and lifetime data management. As a consequence, utilities will be able to substantially improve the efficiency of their business.

Utility assets, such as power transformers, are prime candidates for such real-time integration. And TEC is an ideal means of integrating them. It will be certified to Level 2 (Integration), meaning that it will not only be information enabled and capable of connection to and working well in an Industrial IT system, but also be able to exchange extended data, like status and maintenance data, via defined protocols. Systems with Industrial IT Enabled components offer a variety of advantages, including 'plug and produce' capability. Disturbances are reduced at the same time that flexibility is increased.

### Feature overview

TEC offers a whole range of functions designed to let utilities use their transformers to the maximum. Until now, service criteria have been based on load assumptions and the results of the last service. TEC changes all this. Real-time information opens up new possibilities for optimizing operation and maintenance.

### Cooling/overload forecast

Traditionally, transformer cooling is a two-step system, with the option of 50% or 100% capacity. With TEC, six steps are possible, according to load, ambient conditions and cooler status.

The coolers are controlled individually and can be started prior to an anticipated load increase. This reduces thermal stress and adds hours of operation at maximum capacity.

TEC advanced cooling control is based on algorithms that calculate the heat losses and the number of coolers required to dissipate them. It also keeps track of the number of hours each fan is in operation and runs all motors accordingly. As input, TEC receives data on the actual and/or predicted load and ambient conditions. Armed with this information, the system is able to respond immediately to load peaks, and the cooling capacity can be better adapted to actual demand. Further, it can simulate the results for a specific load condition or forecast the maximum overload duration based on the hot-spot results.

### Real-time status/availability

The parameters measured during service are compared with the simulated values. The transformer model detects discrepancies and indicates potential malfunctions and/or normal wear in the transformer itself, the cooling equipment and the tap-changer.

Real-time information from temperature sensors and from optional moisture sen-

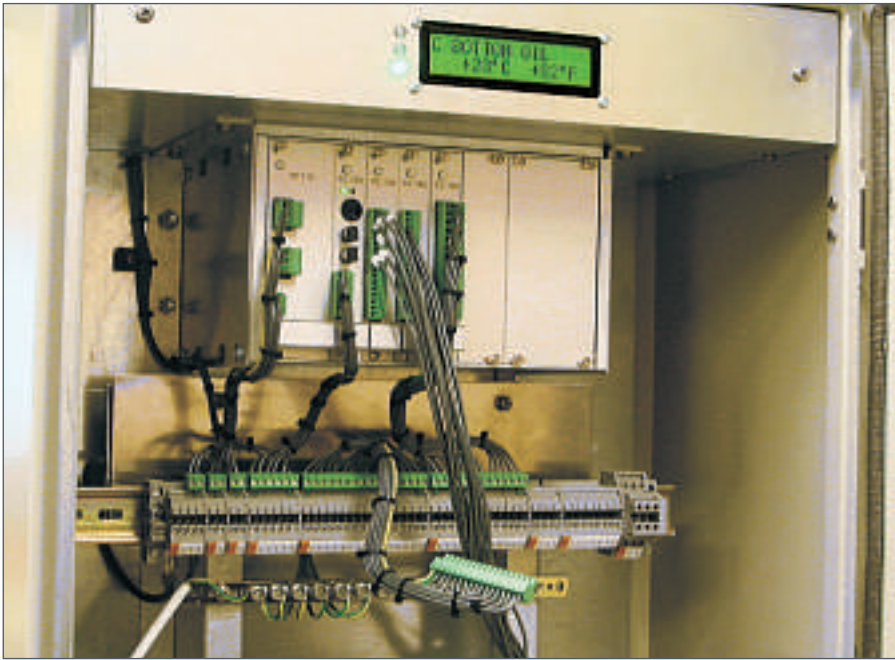

sors is stored by the TEC system. If required, a hydrogen detector can be mounted on the tank to obtain an early indication of potential problems in a transformer winding.

A rolling LCD on the front panel shows the main parameters together with a three-lamp status 'traffic light' (green/yellow/red). The same information can be viewed on a PC terminal, either in the substation control room or at a remote location **2**.

#### Lifetime

Temperature control, based on overload forecasting and winding hot-spot calculations, allows the consumed lifetime to be computed in accordance with the latest IEC and IEEE standards.

#### Event recording

TEC also keeps track of transformer trips and alarms, recording the actual events as well as the sequence to assist

operators in determining their root cause.

#### Condition-based maintenance

The status traffic light identifies the most heavily worn contact in the tap-changer, based on the actual load during each operation. The user sees when the next service is due.

Oil treatment is condition-based, being dependent on the development of moisture as indicated by the temperature and (optional) moisture sensor in the tap-changer compartment.

Early warning is given of any increase in tap-changer temperature beyond the normal value.

#### Operation and updates

The user interface runs in the Windows environment. The PC start panel **3** shows a transformer model with basic data such as the top-oil and bottom-oil

temperatures, up to three hot-spot temperatures, the apparent power and the tap-changer position and operations. More detailed information can be obtained by clicking on the object on the transformer model or by pressing one of the status information buttons.

All of the transformer and tap-changer documentation, including instruction films, can be viewed on the PC in the control room or any other place of convenience **4**.

#### Tried and proven

Environmental tests, hardware/software functional tests and on-site tests in various parts of the world have shown that the system is well suited for substation environments.

ABB's extensive experience with electronic equipment in harsh industrial environments has also been incorporated in the design of the TEC **5**. For example, it is EMC compliant and vibration proof.

#### A modular system

TEC is the first of a generation, and ABB continues to investigate new approaches and ways to improve the system as a whole and in part. Further parameters for the transformer, tap-changer and bushings will be included in the future. TEC's modular design makes this easy, and provides the flexibility that will ensure its success as an innovative and cost-saving product. By giving utilities the means to monitor, and thereby optimize, the way they operate their power transformers, TEC can be said to be truly transforming transforming.

Lars Jonsson

ABB Power Technologies

Power Transformers

Ludvika, Sweden

lars.y.jonsson@se.abb.com

#### Reference

[1] C. Ryttoft, B. Normark: Industrial<sup>T</sup> and the utility industry. ABB Review 3/2002, 23–28.



# Power Systems Consulting

Rana Mukerji

Amid the regulatory transformation that is revolutionizing the utility market, reliability and economics stand out as *the* factors driving financial and operating performance. To get the best return on their assets and perform at the highest level, utilities are turning to solutions that integrate the domain competence of consulting experts with the very latest software tools. New methods for optimizing performance costs have been developed in the course of several recent projects undertaken by ABB.

Power systems consulting is a key ABB offering, enabling customers to plan, operate and maintain their systems in a more economical and reliable way. Consulting work in which ABB is engaged covers a broad spectrum, and includes:

- Planning for grid upgrades
- System performance issues related to voltage, thermal and dynamic stability constraints
- Evaluating and enhancing grid reliability
- Forecasting demand growth for distribution companies
- Benchmarking of utilities relative to global 'best in class' peer groups
- Asset evaluation and reliability centered maintenance planning
- Technical due-diligence in support of mergers and acquisitions

The ABB Consulting group is a global team of more than one hundred power systems experts with local presence in the USA, UK, Germany, Spain, Sweden, Italy, India and China. ABB consultants are backed up by over 6000 product, systems and service specialists in locations close to our customers, enabling the company to identify and implement total system solutions.

## Changes for the better

Just as the rest of the power industry has changed dramatically within the last decade, the art and science of transmission and distribution planning is fundamentally different from what it was ten years ago. Deregulation and performance-based regulations are changing the framework within which planners and system operators work. Considera-

tion has to be given to new technologies on both the load side and the supply side. The changes cover the spectrum of regulatory policy, technology, competition and industry economics.

In recent years, a strong global economy has resulted in demand growth in most companies' service territories. In the majority of companies, even those with overall flat growth, there are pockets of relatively strong load growth in the system for which planners must specify the infrastructure. More than ever, utility planners need to be aware of the equipment installed in the system, as well as its current condition.

Generally, customers also expect a level of reliability as good as, or better than, the reliability they have been used to in

the past. An increasing number of customers operate businesses today that are sensitive to reliability and the quality of service. It is therefore important for utilities to have the tools to systematically analyze cost/performance trade-offs within the financial constraints imposed on them. Similarly, the benefits of available funds should be maximized. This often implies changes to standards, guidelines and procedures.

Interpreting such changes and developing new optimization methods and state-of-the-art software to assist utilities in meeting these challenges is where ABB has vast experience. In just the last five years, new methods for optimizing performance costs have been developed that allow the domain competence of consulting experts and software tools to be integrated in a web-based data warehousing tool. These new methods let us focus on the most cost-effective ways to obtain maximum performance for a system and utilization of assets.

The following two examples show how ABB's experience can be the key factor

in creating optimal, cost-effective solutions for customers based on key performance indicators.

### Reuniting Berlin

On March 5, 1952, as a result of the politics of the time, the electrical supply system of Berlin was divided into two sections, one for the eastern and one for the western zone. Now, five decades later, the two networks, like the two halves of the city, are reunited, having been incorporated in the German interconnected grid. For Berliner Kraft- und Licht (Bewag) AG, the utility responsible for running the network in the western half of the city, joint operation of the two networks posed certain problems. Besides the obvious need for standardization – different system philosophies had developed over the years – it was also apparent that a concept was needed for the city's electricity supply in the longer term.

Investigations were carried out to find an optimal concept for the reunited distribution networks of Berlin that took all factors into account. Bewag and

ABB formed a joint planning group to develop the approach. Its main objective was to make the two networks more compatible so that the city would be able to cope with future electricity demand.

One of the issues looked at especially closely was the reliability of the downtown area networks, and at ways to increase it without making any basic changes to the supply concept. In particular, it was necessary to find out if, and what, additional investments might be required to achieve the goal of higher reliability.

With the help of advanced mathematical modeling of the system components and special programs for the calculations, certain system components were loaded beyond their conventional nominal power. This showed which components could be utilized more economically. As a result of this study, Bewag decided to increase the capacity of transformers and underground cables used in the networks.

### Utility gets results

The second example involves an electrical utility company providing power to several regions in Europe. In order to benchmark some of their guidelines, practices and power quality indexes, they wanted a comparison with utilities in Germany and the United States that would identify 'best practices'. To this end, studies were carried out in the areas of maintenance, transmission and distribution planning, and engineering and operations.

In addition to providing a benchmark for these four areas, ABB undertook reliability calculations for the utility's power distribution system. This was done to obtain a baseline for its distribution design practices at the time, as well as an on-site diagnosis of certain facilities.

ABB found differences between the utility's practices and typical practices in Germany and the USA, especially in the maintenance area. It was seen that a change in procedures could result in

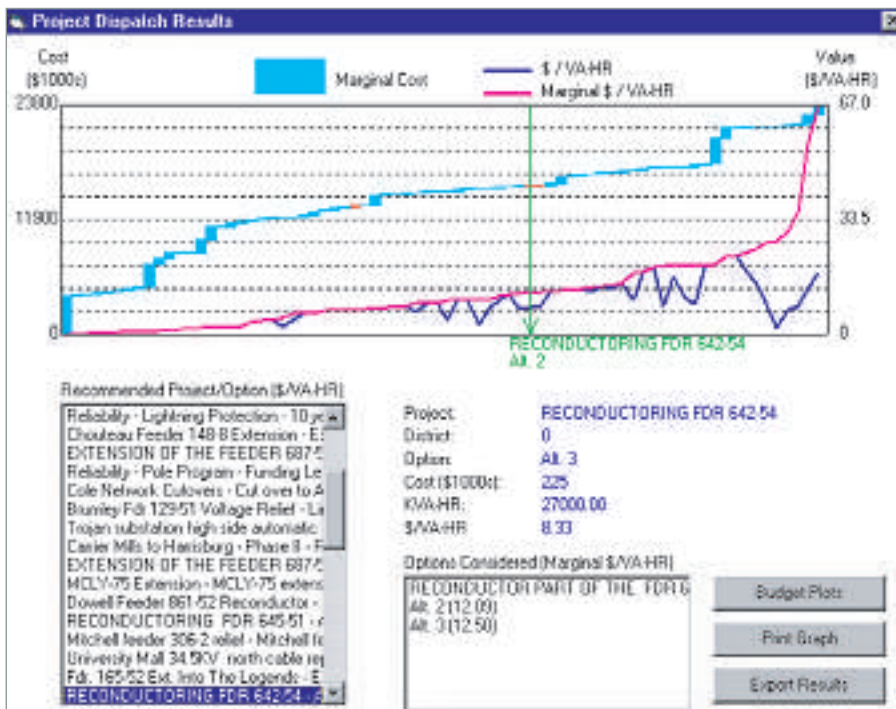

Distribution transformer density data, imported from a utility's transformer load management program and used in load forecasting



Load forecast study performed using a commercially available GIS database as starting point

considerable cost savings without significantly affecting reliability. The study also recommended use of some of the newer probabilistic approaches to system planning which help minimize the cost of new investments.

After receiving the study results, the utility indicated that it was “very impressed by ABB’s ability to set up a cross-border team in such a short time to cope with a challenging project with a very tough deadline.”

### Business processes and asset utilization

In another example, ABB instituted ‘budget-constrained’ planning policies and methods appropriate for a regulated US ‘wire company’ operating in a competitive environment. The project included:

- A review of all engineering planning and budgeting procedures, reliability requirements, engineering criteria, planning guidelines, and appropriate standards, as well as planning, budgeting and engineering results from the past ten years.
- Development and implementation of a new planning/budgeting/project prioritization method based on marginal benefit/cost optimization using customer service quality costs as well as budget cost as an element of performance evaluation.
- Design of an entirely new planning process and organization, compatible

with the new planning methodology and tailored to the company’s new goals and needs.

- Seminars and workshops for over 220 engineers, managers and supervisors from 14 operating districts, to convey the concepts and skills necessary to implement the new approach.

Another project undertaken by ABB involved investigating the operations and maintenance history and procedures of a Texas utility’s underground distribution and transmission cable systems in the Dallas, Fort Worth and DFW airport service areas. The investigation included reliability assessments of the transmission and distribution systems using a network model. Also included were inspections of parts of the utility cable networks, substations and pumping stations, as well as interviews with utility operations, engineering, and maintenance personnel. The investigation further included a review of utility standards, guidelines and documentation relevant to the operation of the cable network.

### Power system performance research

Another area in which ABB is active is in research into power system performance and the development of new technologies for its improvement. In one such project, named ‘Wide Area Disturbance’, we examined, among other things, voltage instability, overload and out-of-step.

Based on this, we developed a new algorithm for estimating the proximity to voltage collapse. The method employs only local measurements – bus voltage and load current – and is simple enough to be implemented in a numerical relay. The relay’s estimation can be used for a number of applications, for example to enhance local controllers (SVCs, etc) or to direct load shedding. Alternatively, the estimation can be sent to a computing center as support for system coordination.

Other completed projects, eg ‘Robust Control of FACTS Devices’ and ‘Control of Nets, Drives and Converters’, have examined the algorithms for damping power oscillations under uncertain operating conditions. Uncertainties



Screenshot taken from a budget-constrained planning software simulation

included transmission outages and varying load profiles. New algorithms and software for centralized and decentralized robust controllers were developed and tested by means of simulations on realistic system models.

Backing up ABB’s consulting business is domain expertise and field experience accumulated over decades in the power industry, plus a global presence that allows us to bring best practices from all over the world together to help our utility customers improve their business performance.

**Rana Mukerji**  
 ABB Power Technologies  
 ABB Inc.  
 Raleigh, NC, USA  
 rana.mukerji@us.abb.com

# The big picture

Detecting power system instabilities and optimizing asset utilization with InformIT Wide Area Monitoring PSG 850

Joachim Bertsch, Cédric Carnal, Andreas Surányi

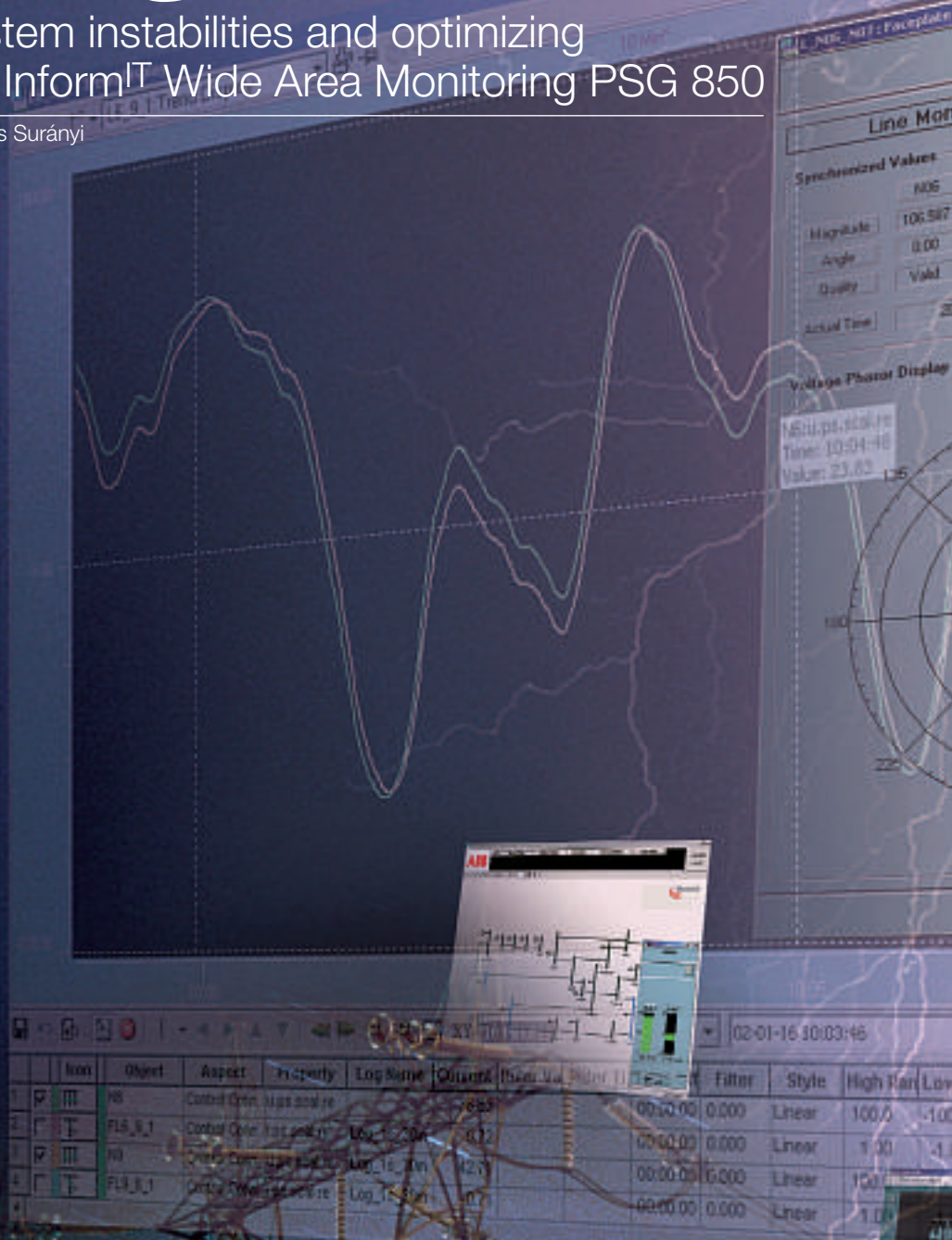



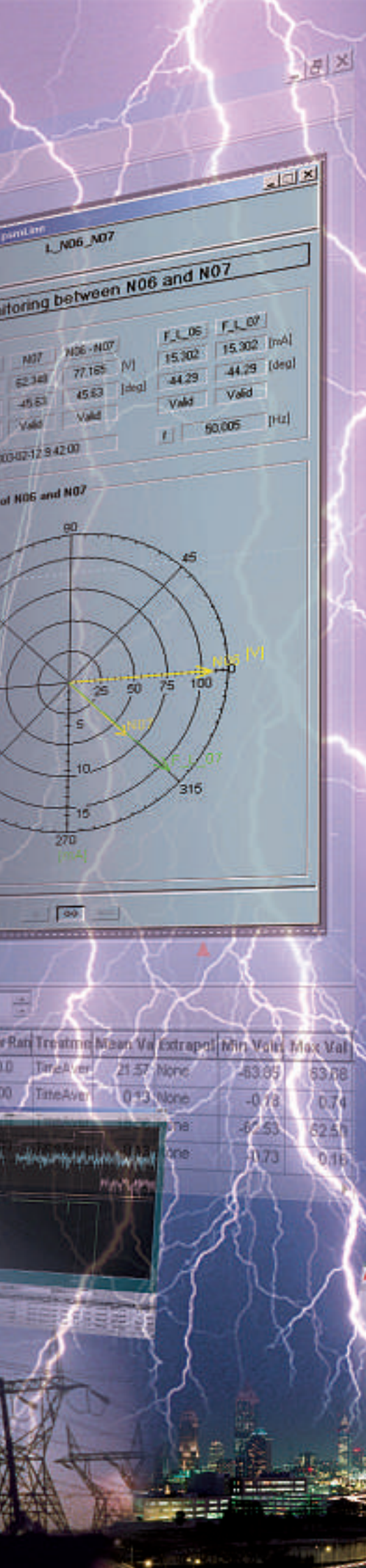

Developments in the world's power markets are compelling utilities to place greater emphasis on asset utilization in order to operate more profitably. But there is an equal need, as the recent massive blackouts in North America and Europe showed, to have safeguards in place that ensure total reliability for the transmission networks.

Increasing attention is therefore being given to the monitoring of power system dynamics. This requires information of higher accuracy and with update rates faster than those normally provided by traditional SCADA systems. In addition, it has to be synchronized over a wider geographical area than traditional protection systems allow.

With the introduction of phasor measurement units and recent advances in communication and computing it has become technically feasible to take a wide area approach to monitoring power system stability on-line. Inform<sup>IT</sup> Wide Area Monitoring PSG 850 was developed as a state-of-the-art platform for just such an approach. IT-based, it offers solutions designed to optimize asset utilization as well as to prevent entire power networks from collapsing.

The world has come to depend on electricity so much that huge efforts – and investments – have to be made to ensure that it flows uninterruptedly. Apart from having to find the capital for this, the electric utilities are faced with another problem: market pressures are forcing them to maximize their profitability. Together, these factors provide a strong incentive for utilities to install technology that combines functionality for optimizing asset utilization and cost structures with that required to prevent power system outages. This is precisely what Inform<sup>IT</sup> Wide Area Monitoring PSG 850 – one of a family of PSG modules/packages that also include wide area protection and control (PSG 870), wide area measurement (PSG 830) and wide area connectivity (PSG 810) (see figure on page 34) – was developed for. Inherent benefits of the PSG 850 solution include:

- Transmission capacity enhancement, achieved by on-line monitoring of the system safety or stability limits.

- Power system reinforcement (investment planning), based on feedback obtained during analysis of system dynamics.
- Introduction of a coordinated approach to stabilizing actions in cases of severe network disturbance.
- Triggering of additional functions, such as var compensation.
- Better understanding of a system's dynamic behavior.
- Installation of an early warning system designed to prevent potential blackouts.

#### Data utilization in wide area monitoring

Monitoring of entire power systems with PSG 850 is based on dynamic phasor measurement – increasingly being seen as the ultimate in data acquisition technology. Phasor measurement units (PMUs), located in critical areas of a network, allow fast measuring of the voltage and current phasors (ie, their magnitude and phase angles) and optimize process control on the basis of a dynamic,

highly accurate system overview. Several electrical utilities have already deployed PMUs in their grids, mainly for manual data acquisition and processing.

A key feature of wide area monitoring systems is the central acquisition of data from PMUs, enabling utilities to utilize phasor information wherever it is needed. PSG 850 provides the following customized forms of data utilization in support of utilities' asset management targets.

**Monitoring of dynamic system behavior – stability assessment**

At present, power system operation tends to be based on static or quasi-dynamic information extracted from rms measurements, mostly using SCADA systems. Phasor measurements at important nodes help system operators gain a dynamic view of the power system and initiate any necessary stabilizing measures in good time. Significant support is provided by stability assessment algorithms, which are designed to take advantage of the phasor measurement information. This increases the efficiency of power system operation and helps to maintain security at the desired level.

**Monitoring of transmission corridors – congestion management**

Energy is often traded over the transmission corridors interconnecting the power systems – an activity that adds

significantly to the cost, and therefore price, of energy in liberalized markets. However, the transmission capacity of such corridors is often constrained by stability concerns having their origin in uncertainty about the underlying system status. The traditional solution – to reinforce transmission path capacity by installing new lines – has the advantage of offering high availability, but also the substantial disadvantage that line construction is time-consuming and requires huge new investments.

An alternative solution is to significantly improve asset utilization through wide area monitoring. This reduces uncertainties and, consequently, the operational risks. Under certain conditions, such as lower-than-assumed ambient temperatures, the dynamic capacity increase can be significant. The smaller investment makes the ABB solution far more cost-effective than installing new lines. For example,

Phasor measurements at important nodes help system operators gain a dynamic view of the power system and initiate any necessary stabilizing measures in good time.

a 4 to 6 % increase in transmission capacity achieved by deploying a wide area monitoring system could help to postpone or even avoid major investments worth 10 to 100 million USD. PSG 850 is therefore also an important

decision support tool for congestion management and investment planning.

**Disturbance analysis and system extension planning**

The continuous data storage functionality provided by PSG 850 is a very valuable source of information for the analysis of incidents and disturbances occurring in the power system. Besides improving the efficiency of power system analyses, it helps to determine and eliminate the actual causes of such inci-

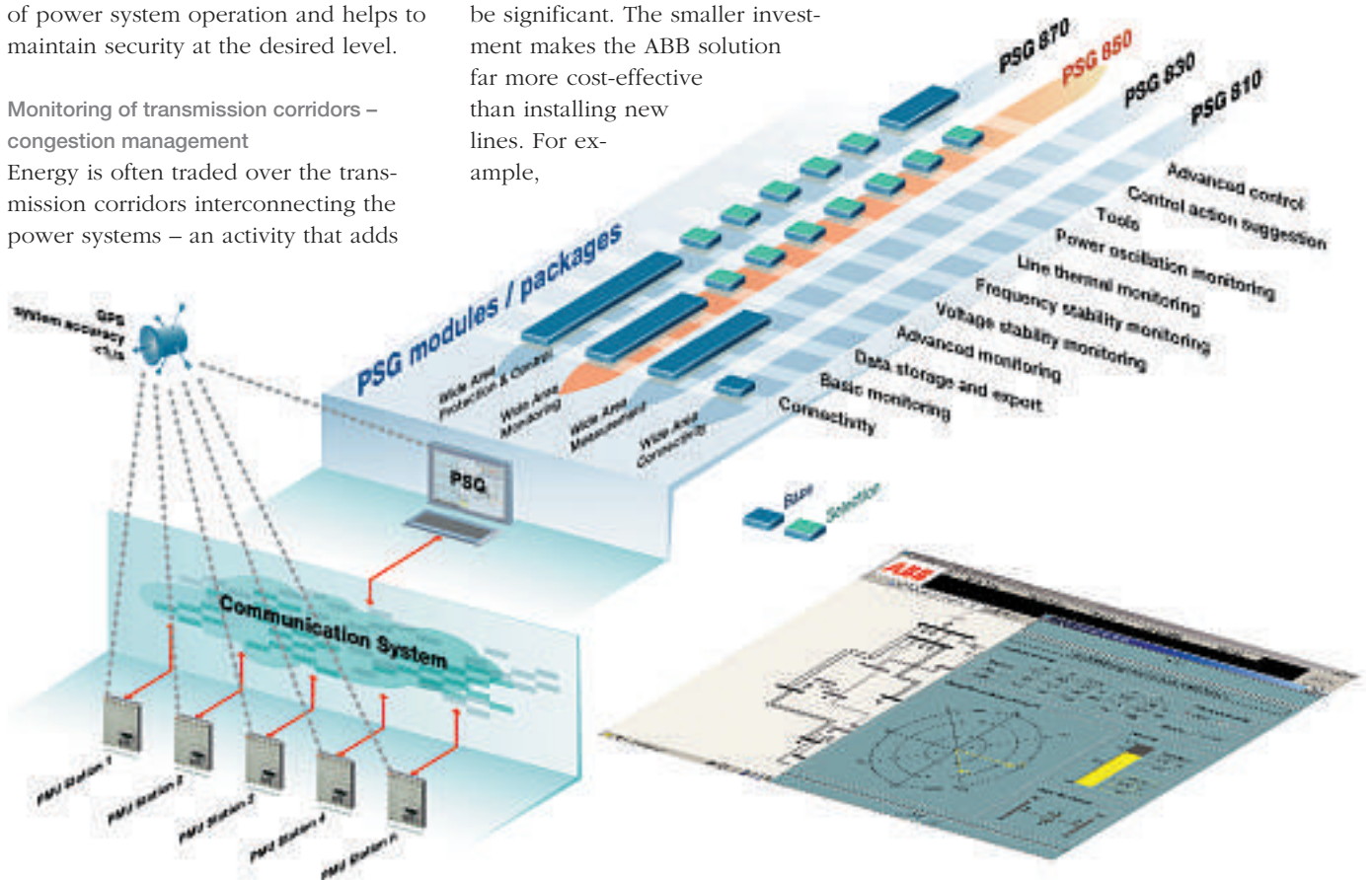

dents. This accurate identification provides a sound basis for the planning of system expansions and future system reinforcements.

### System platform overview

**Phasor measurement as basic technology**  
Wide area monitoring systems are essentially based on new data acquisition technology. Unlike conventional control systems, which use, for example, RTUs to acquire the rms values of currents and voltages, a wide area monitoring system acquires GPS<sup>1)</sup>-synchronized current, voltage and frequency phasor information measured by PMUs at selected locations in the power system. The measured quantities include both magnitudes and phase angles, being time-synchronized via GPS receivers with an accuracy of one microsecond. Until now, critical nodes in transmission grids have usually been monitored using static or quasi-dynamic data based on rms measurements. Phasors, measured at the same time, provide instant snapshots of the status of the monitored nodes. By comparing these snapshots, both the dynamic and steady state of critical nodes in transmission and sub-transmission networks can be observed. The result is *dynamic monitoring* of the power systems.

Wide area monitoring is essentially based on new data acquisition technology, with GPS-synchronized current, voltage and frequency phasor information measured by PMUs at selected locations.

#### System architecture of the wide area monitoring platform

The platform architecture for monitoring is made up of the following hardware:

- Phasor measurement units
- Communication links
- System monitoring center

PMUs are placed in the substations to allow the power system to be observed under all the different operating condi-

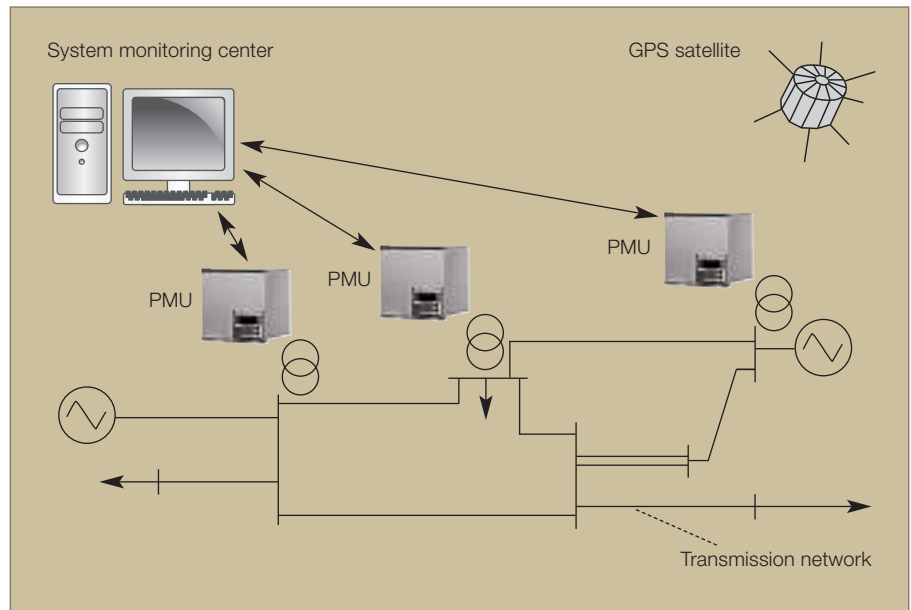
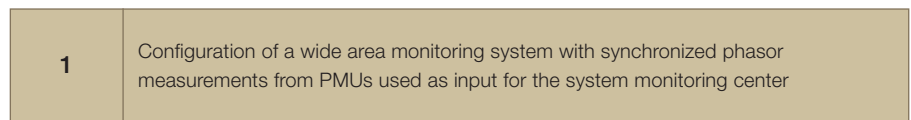

tions (network islanding, line or generator outage, etc). Some redundancy is provided to secure this information in the event of certain data being unavailable, for example due to PMU outage or communication failure. The measured data are sent via dedi-

cated communication channels to the PSG 850's system monitoring center (SMC) – a central computational unit in which the collected data are synchronized and sorted **1**. This provides a snapshot of the power system's status.

In the case of meshed network topologies, the snapshot is then processed by the basic monitoring (BM) package, which is part of the SMC. BM denotes the set of algorithms included in all installations of the wide area platform as the basis for different software applications. This solution package has the following capabilities:

- Ability to provide consistent input data for all PSG 850 applications.
- Fast execution, leaving sufficient time to run additional applications within the sampling interval.
- Robustness – the system is resistant to the poor quality of some of the input data (availability, range, synchronization)

The reference phasor can be chosen from various points in the grid. Software applications, which are linked to the BM output, address various dynamic phenomena occurring in power systems. They predict the state of the power system and suggest appropriate action to be taken by the system operators when an emerging instability is detected. An ergonomic graphical user interface (GUI) **2** displays the output information.

Historical data can also be accessed, allowing phasor data to be retrieved for subsequent analysis. A navigation facility is provided for easy selection and display of the required information.

#### Implementation activities and advanced software applications

To take full advantage of Inform<sup>IT</sup> Wide Area Monitoring PSG 850, a step-wise

<sup>1)</sup> GPS Global Positioning System

Example of graphical user interface display provided by PSG 850. The popup line monitoring faceplate (on right) compares voltage phasors.

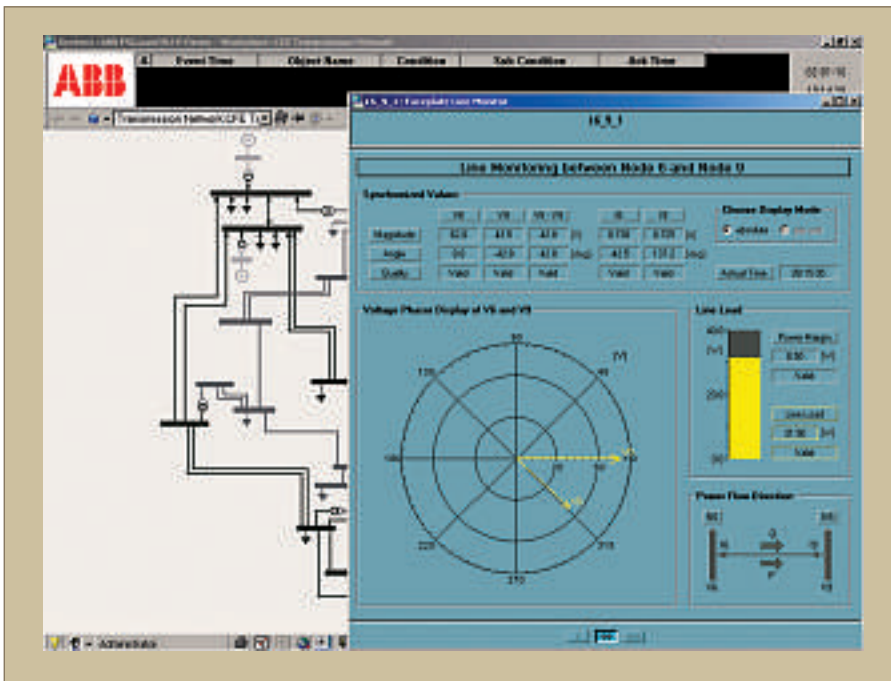

- Increased grid utilization, facilitated by on-line monitoring of critical nodes.
- Detection and elimination of causes of power quality problems, made possible by the high accuracy of the underlying system of measurement.
- Thorough investigation of critical incidents.
- Provision of additional strategic information for the utility's grid planning department.

As a result of this positive feedback, several wide area monitoring pilot projects are now having their status upgraded to 'ready for commercial exploitation.'

### Wide-ranging benefits

Experience with installed prototypes shows that wide area monitoring systems help to significantly improve grid utilization, especially during peak demand periods. Just as importantly, they facilitate detection of the critical factors influencing a network's fundamental stability.

When a wide area monitoring system is installed, utilities that operate power lines at high load levels can reduce their costs substantially by postponing investment in new infrastructure while still maintaining high grid availability.

In this context, Inform<sup>IT</sup> Wide Area Monitoring PSG 850 goes well beyond the capability of existing local monitoring and protection equipment. It raises the level of asset utilization and can significantly contribute to future cost savings in a utility's long-term strategic investment planning.

approach is recommended: First, the utility and the PSG 850 supplier carry out an initial study to identify typical network problems and the most endangered of the areas in which the system is to be deployed. Afterwards, the appropriate monitoring algorithms and most suitable locations for installing the PMUs can be chosen. ABB has developed a complete set of algorithms that ensure optimized procedures during the various stages.

The fundamental software modules include a GUI (with single-line diagram, pop-up windows, trend displays), easily scalable PMU connectivity package, data storage capability and export functions for further analysis.

The following software applications are offered with Inform<sup>IT</sup> Wide Area Monitoring PSG 850:

- Advanced monitoring
- Voltage stability monitoring for transmission corridors
- Line temperature monitoring
- Power oscillation monitoring
- Frequency stability monitoring
- Control action suggestions

### Customer feedback has been good

Several systems with up to 16 PMUs have already been installed or engineered for practical application in high-voltage power grids. Feedback from prototype applications on customer

sites is diligently recorded, and continues to confirm improvements in power

system performance. Evaluation of the feedback shows that customer benefits include:

- Cost-effective grid operation based on observation of critical network areas.

Maximum benefit is gained from wide area monitoring when the utility and ABB jointly identify typical network problems and the most endangered areas.

**Joachim Bertsch**  
**Cédric Carnal**  
**Andreas Surányi**

ABB Power Technologies  
CH-5400 Baden/Switzerland  
joachim.bertsch@ch.abb.com  
cedric.carnal@ch.abb.com  
andreas.suranyi@ch.abb.com



# Industrial<sup>IT</sup> and the utility industry

Claes Ryttoft, Bo Normark

**ABB's Industrial<sup>IT</sup> has been discussed often in the pages of ABB Review, and its benefits, especially for automation, manufacturing and production applications, have been explained in detail. But what about the utility industry? How is Industrial IT contributing to this important area of ABB business and how can the unique business environment of the utility industry profit from it?**

The utility industry is undergoing a fundamental transformation. The change from a vertically integrated industry, often under national control and with only limited competition, if any at all, to a fully competitive, deregulated industry is dramatic in all its implications. On top of all this, the product involved, electrical energy, is vital to the development of nations. The US Department of Energy has put this clearly into perspective by stating:

*“Electricity is a cornerstone on which the economy and the daily lives of our nation’s citizens depend. This essential commodity has no substitute. Unlike most commodities, electricity cannot easily be stored, so it must be produced at the same instant it is consumed. The electricity delivery system must be flexible enough, every second of the day and every day of the year, to accommodate the nation’s ever-changing demand for electricity. There is growing evidence that both private and public action is urgently needed to ensure our transmission system will continue to meet the nation’s need for reliable and affordable electricity in the 21st century.*”

IT solutions will be a key area for utilities in this new and fast-changing market. Only IT solutions can successfully provide enough flexibility and intelligence to accommodate changes in the market such as price erosion, investment uncertainty and demand for higher reliability.

## Price erosion

The introduction of competition has, in most cases, led to significant reductions in electricity prices, as in Europe, where the electric utility industry has been undergoing restructuring for the last ten years **1**.

Industrial customers are usually the first to benefit from increased competition. Subsequent opening of the individual consumer market is accompanied by strong pressure on electricity prices across the board; in Sweden more than 30% of customers have changed their electricity supplier since reform was introduced just a few years ago.

The consequences of the increased competition are that the utilities have

to better utilize existing investments, which are very capital intensive, to enhance their value, and also ensure the highest possible return on future investments. At the same time, operation and maintenance costs are becoming more critical.

## Investment uncertainty

In a non-competitive environment, planners had only to consider the load growth per region and structure the investments accordingly. The regulatory framework and the customer base were stable and this made planning easy. The main focus was on security of supply, and costs for investments, operation and maintenance were simply passed on to the consumer.

With the unbundling of generation, transmission and distribution activities, totally new conditions were created for the utilities. Competition is normally introduced in the generation business, whereas transmission is often left regulated. Different models are applied to distribution, but as a rule the regulator pressures the distributor to be com-

1

Electricity price development for industrial customers in Europe 1995–2000 (1995=100). The blue, green and red curves assume a 100%, <100% and <40% market liberalization, respectively.

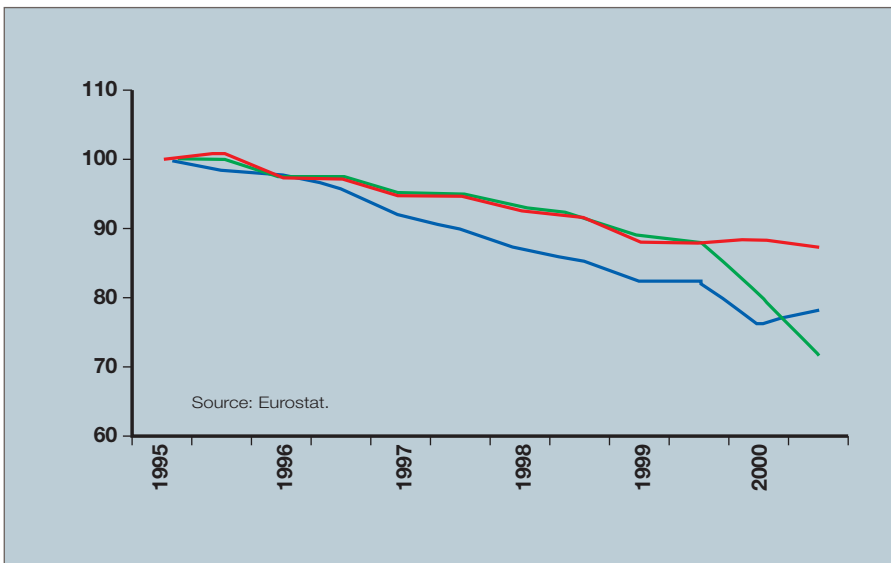

petitive. This has resulted in a large increase in investment uncertainty.

Electricity is fast-becoming the largest traded commodity in the world. The keys to success in this marketplace are the ability to master real-time market data and information about the capabilities and limitations of resources, and having efficient tools for asset management.

One initial reaction of the utilities has been to cut back on investments, but this is not a sustainable strategy. Public response to some spectacular black-outs and supply shortages has resulted in pressure for more stringent regulation.

### Reliability expectations have grown

The traditional utility could provide a secure supply of electricity since cost was not considered to be too important. However, in the new competitive business environment, strict cost control has to be given equal attention. Something else making supply security increasingly important is the fact that the loads are

becoming more and more sensitive to supply quality.

Inadequate reliability not only puts a company's image on the line, it can also damage its balance sheet by making it liable to pay penalties to customers.

### How Industrial<sup>IT</sup> supports utilities in the new business environment

#### Information

The most fundamental prerequisite for all performance enhancements based on IT is access to information. However, the traditional mix of mutually incompatible and slow information creation, storage and retrieval methods simply have no place in the new, fast-changing energy world.

ABB's Industrial<sup>IT</sup> concept will make it possible to create, store and retrieve, in real time, all the information that a system will need to operate as efficiently

as possible. There will be none of the barriers that have traditionally separated information provinces, such as mechanical and electrical, technical and business, operation and maintenance, and software and hardware.

The key to ABB's Industrial IT is Aspect Object<sup>TM</sup> technology [1]. An *Object* is defined as a software container which keeps together all the characteristics, called *Aspects*, of a piece of equipment, be it switchgear, a transformer or any other device. Aspect Objects can be combined to model a complete station, as shown in 2.

When multiple products are combined to form a system or solution, physically putting each device into place is the easy part. The difficult part is collecting, and keeping up-to-date, all the related information (configuration, drawings, maintenance records, etc), as this is often stored in different formats and in different locations.

Industrial IT from ABB will change this. Once the physical device is put into place, the operator can simply copy and paste the model Aspect Object into the overall system monitoring and control strategy. No matter where each real object is deployed, one 'click' on the model Object provides a link to its Aspect information.

Although certain Aspects (drawings, instructions, etc) may not change over time, others (eg, configuration, efficiency, cost of ownership) must be frequently updated. The Industrial IT architecture provides a way to automate this process, and to help various devices 'learn' from each other by exchanging real-time Aspect information.

#### Integration

ABB's common Industrial IT architecture makes it possible to integrate many different *applications* as Aspects, allowing them to be seamlessly linked in real time. It is even possible to integrate the applications without any changes and it is not even necessary for the different applications to be aware of each other. In addition, they could be from ABB,

Success in the power market depends on having real-time information about the capabilities of resources, and efficient tools for asset management.

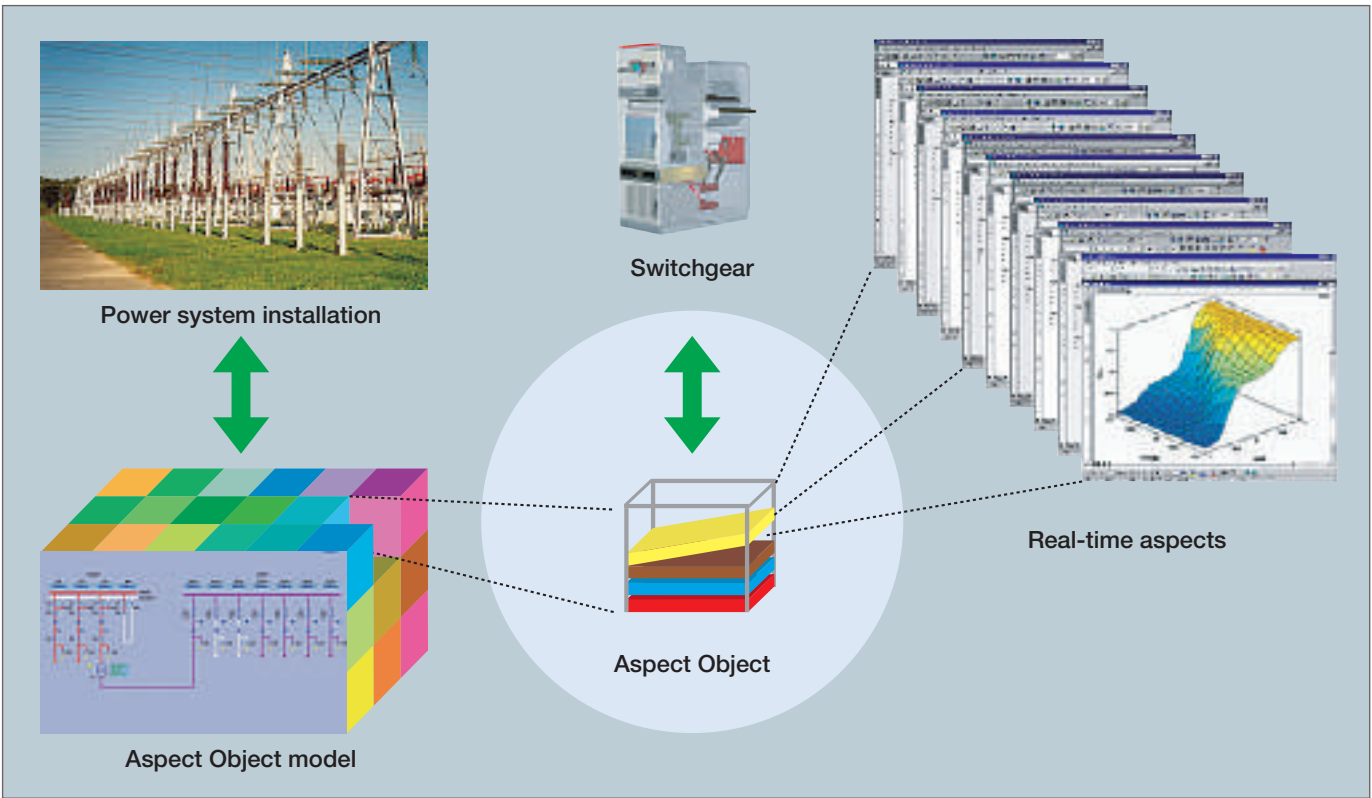

but could just as well be any third-party or customer application such as Word, Excel, ERP, a web camera, or a Computerized Maintenance Management System (CMMS) 3.

advantages arise from combining the integration with added functionality and optimization.

The integration functionality of the Industrial IT architecture is unique in that it allows logical integration of

This, in turn, engenders entirely new conceptual solutions. It is well known from other industries that when components, systems and solutions are adapted for integration, totally new and much more efficient solutions are made possible.

Normally, the first step in integration is to copy the traditional products and systems into one common system. Since the different functions can share interface and computing capability, a saving in both hardware and software is certain.

The second step in the integration is to start utilizing the available information to build completely new functionality in the integrated system. The biggest

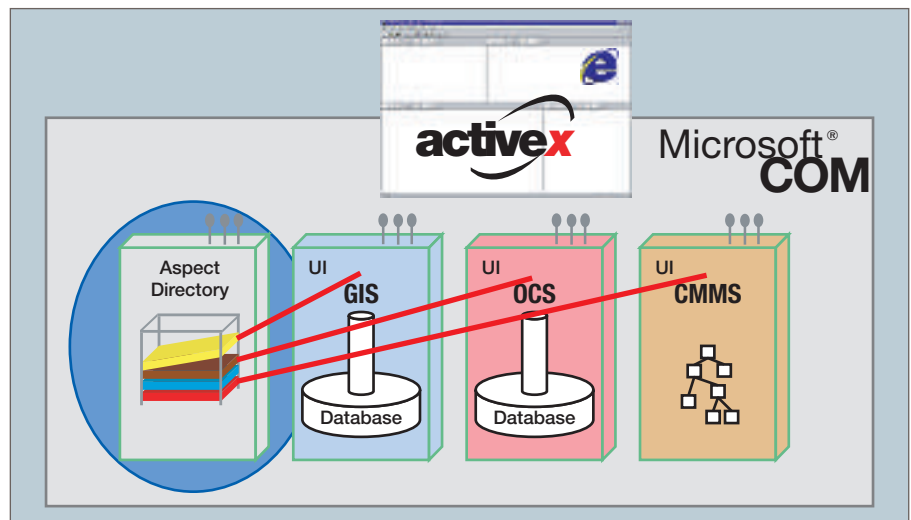

**4** Integrating a SCADA/EMS system with a Computerized Maintenance Management System allows an operator to issue an error report in the CMMS when something happens in the plant.

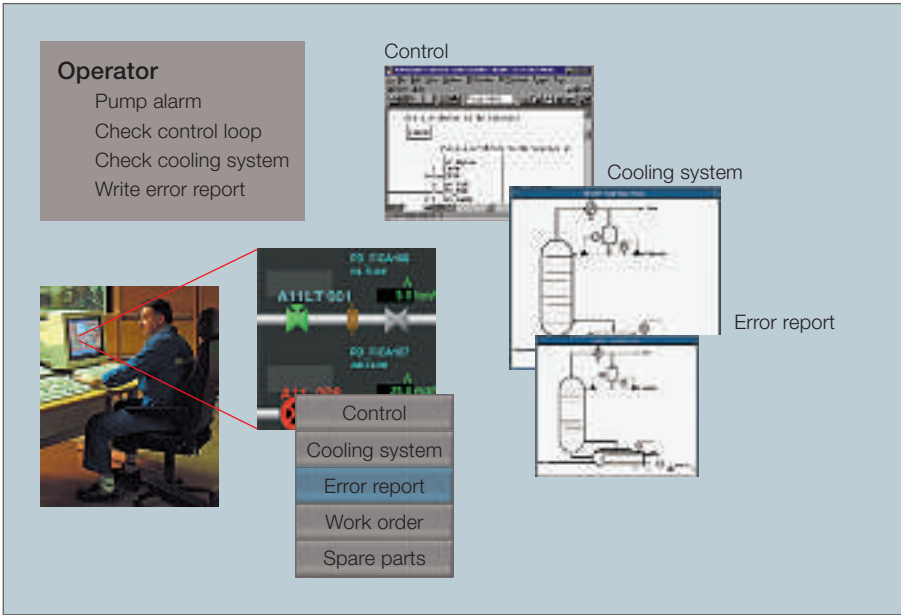

independent applications without requiring any changes to them. A practical example of this could be to integrate an OCS system with a CMMS, thus allowing an operator to issue an error report in the CMMS when something happens in the plant. The report can be

initiated by just right-clicking with the mouse on the faulty object and then selecting the CMMS Aspect **4**.

In the ABB Object architecture, such flexibility is provided by an *Aspect Directory* which interfaces between

applications. When an application is installed in the system it registers all interfaces that it supports with the Aspect Directory. When any application wants to perform an operation that involves action by other applications, it queries this Aspect Directory for references to all interfaces that implement the operation, and then invokes these interfaces, one by one.

To copy and paste an object, for example, all applications that implement Aspects defined for the object must be involved and perform their part of the operation, each application copying and pasting its Aspect respectively.

**Industrial IT based automation platform**

ABB utilizes the Aspect Object technology both as an integrated part of the new automation platform and as a solution for integration of hitherto independent applications, thus providing an improved workflow for ABB customers.

The automation platform will span traditional functions such as DCS, PLC and SCADA functionality. In the platform, the Aspect Object system will be used to keep track of all information about an object connected to the system, eg a controller, where the different Aspects might be an alarm list, control logic, documentation, graphics, etc.

Importantly, the operator is provided with a tool with a familiar 'feel' **5** for easy navigation through the information hierarchy. This 'Plant Explorer' is a browser that allows navigation through the various structures and viewing of the Aspects defined for each object.

**Optimization by integrating solutions**  
 Advantage may be taken of the added functionality arising from an integrated solution to optimize the performance of the entire system. This opens up spectacular possibilities, such as combining real-time information and added functionality. For example, starting from

- Production cost forecasting
- Capability limitations in production
- Static and dynamic capability, with margins in the system for both

**5** The Plant Explorer lets users navigate through the information in a way they are familiar with.

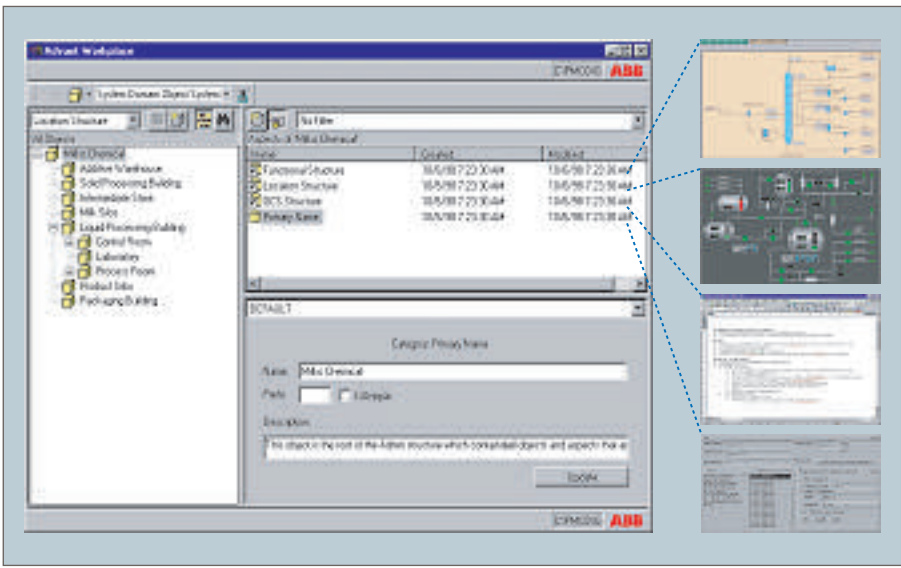



- Information needed for demand-driven maintenance
- Information needed for disturbance prevention and mitigation, it is possible for users to take this information and start combining as follows:
  - Market prices, current and future. How can I combine this with production cost forecasting?
  - Demand forecasting. How can I use this information together with capability limitations, maintenance scheduling and disturbance prevention?
  - Maintenance scheduling. How can this be combined with market pricing, demand forecasting and capability limitations to minimize the consequential cost of maintenance?
  - Capability limitations. How can this be combined with static and dynamic capability margins to ensure maximum utilization without reducing the reliability?

### Industrial IT certification

To ensure all ABB products adhere to the Industrial IT architecture, a certifica-



### Industrial<sup>IT</sup> for utilities

Industrial IT is an overall strategy for ABB with major benefits for the utility industries:

- A new, modern automation platform in which Aspect Objects is an integrated feature and which will be introduced for power plants, water applications and substation control and protection.
- A unique integration architecture that will make it possible to integrate existing utility applications.
- A certification process that guarantees that ABB, and many third-party, products will fit seamlessly into the Industrial IT architecture.
- A new transparent naming strategy that makes it easy to understand ABB's product and solution offerings.

tion program has been launched. It is planned to certify *all* ABB products, including all power technology devices such as transformers, switchgear, etc. By mid-2003 over 30,000 ABB products were certified at the basic certification level. More advanced certification levels (Information, Connectivity, Integration and Optimization are foreseen) as well as certification of solutions will follow. The certification program is open for third-party products and it is ABB's ambition to establish the Industrial IT architecture as an industry *de facto* standard.

### Structured customer offerings

All offerings compliant with the Industrial IT architecture will have a consistent naming structure that is descriptive in its nature. That means that names will directly guide the reader to whatever application or use is addressed. For ABB's utilities business, the naming policy has been applied according to the following structure (with examples):

- Solution Portfolio (Industrial IT for Power Generation)
- Solution Suite (Industrial IT for Combustion Management)
- Solution (Industrial IT Carbon in Ash Monitor)
- Product (Control<sup>IT</sup>, Process Controller, AC 800M)

### Market introduction

Industrial<sup>IT</sup> for Utilities will be introduced to the market in a step-wise fashion, with products and solutions being gradually certified to comply with the four levels of Industrial IT compliance. The first, smaller power plant and water automation systems based on the new automation platform are already up and running.

A key goal in the introduction program is to develop new solutions around the Aspect Object architecture.

**Claes Ryttoft**  
**Bo Normark**

ABB Power Technologies  
CH-8050 Zurich  
Switzerland  
claes.ryttoft@ch.abb.com  
bo.normark@ch.abb.com

### Reference

[1] The ABCs of Industrial<sup>IT</sup>. ABB Review 1/2002, 6–13.

# Cold storage

The battery energy storage system for Golden Valley Electric Association

Tim DeVries, Jim McDowall, Niklaus Umbricht, Gerhard Linhofer

**Alaskan winters are cold. Where temperatures can drop to minus 50°C, power outages are very bad news indeed. A reliable supply of electricity is given a high priority when your water pipes can freeze solid within hours if the power goes down!**

**One way to prevent this happening is to have an emergency power source feed energy into the grid until back-up generation can be made available. An economically and ecologically more viable alternative to ‘spinning reserve’ – gas turbines kept running in case of an emergency – is battery back-up. In August this year, the world’s largest-ever battery energy storage system was inaugurated in Fairbanks, Alaska. In addition to stabilizing the local grid, it will reduce power outages in the area by 65%. A consortium led by ABB supplied and installed the system.**

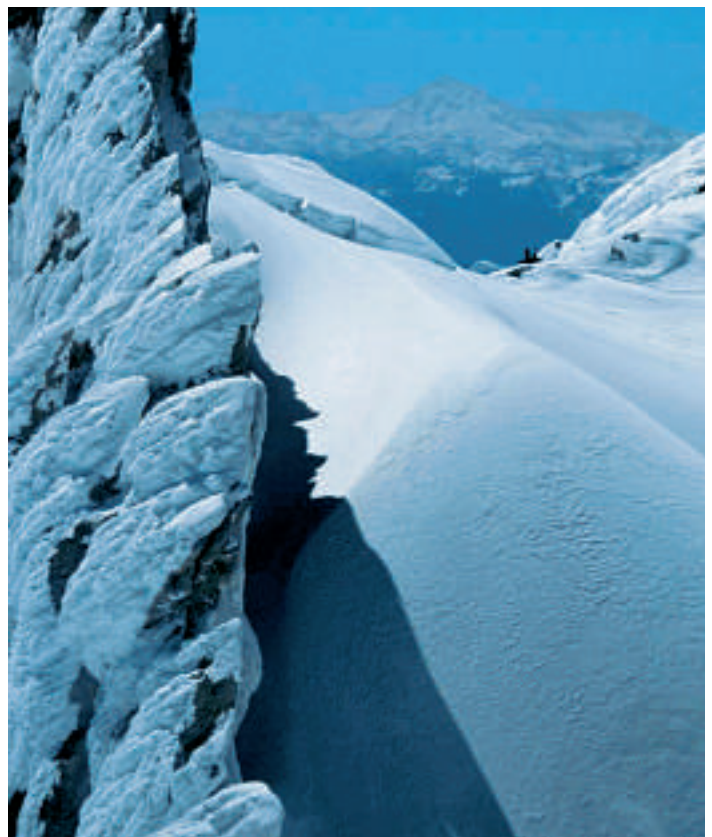

Golden Valley Electric Association (GVEA) is a rural electric cooperative based in Fairbanks, Alaska, serving 90,000 residents spread over 2200 square miles. A reliable supply of electricity is essential to the local population since many residents live in remote areas and winter temperatures can fall as low as minus 50°C. Back-up power therefore has to be available in the event of an outage.

Traditional solutions for providing reserve power require building and maintaining transmission and generation capacity well in excess of normal demand.

GVEA’s decision in favor of a battery energy storage system (BESS) reflects its commitment to installing a system that is a cost-effective and efficient alternative to these solutions.

## **15 important minutes**

At the heart of the world’s most powerful storage battery system are two core components: the converter, designed and supplied by ABB, and nickel-cadmium (Ni-Cd) batteries, developed by Saft. The converter changes the batteries’ DC power into AC power, ready for transmission over the GVEA grid. The batteries constitute the energy storage medi-

um. They can produce up to 27 MW of power for 15 minutes, giving the utility enough time to get back-up generation on line. While the BESS is capable of producing up to 46 MW for a short time, the client’s primary need is for the system to cover the 15-minute period between sudden loss of generation and start-up of back-up generation.

Although the BESS is initially configured with four battery strings, it can readily be expanded to six strings to provide a full 40 MW for 15 minutes. The facility can ultimately accommodate up to eight battery strings, providing flexibility that

will allow the client to boost output or prolong the useful life of the system beyond its planned 20 years.

### System and project requirements

The final specification required that the vendor provide a turnkey solution and guarantee for twenty years that the BESS could supply 40 MW for 15 minutes, with a 4 MW/min ramp-down after the 15-minute mark. The system is required to be capable of operating in all four quadrants (ie, the full power circle) and to provide continuous, infinitely adjustable control of real and reactive power over the entire operating range. The specification also required that the BESS be able to operate in an automatic mode, as GVEA does not plan to man the facility.

Rated output had to be provided for the following power system characteristics:

- Nominal voltage of 138 kV (1.0 pu)
- Normal sustained voltage of 0.90 pu (min) and 1.1 pu (max)
- Normal frequency of 60 Hz, with normal deviation of +/- 0.1 Hz
- Sustained frequency range of 59.0 Hz (min) and 60.5 Hz (max)

### Seven operating modes

The BESS is able to operate in seven distinct modes:

- *Var support*: The BESS provides voltage support for the power system under steady-state and emergency operating conditions.
- *Spinning reserve*: In this mode, the BESS responds to remote generation trips in the Railbelt system. It is initiated at a system frequency of 59.8 Hz, with the BESS loading to full output at 59.4 Hz if system frequency continues to drop. Spinning reserve has the highest priority of all the modes and will interrupt any other mode the BESS is operating under.
- *Power system stabilizer*, included to damp power system oscillations.
- *Automatic scheduling*, used to provide instantaneous system support in the event of a breaker trip on either a transmission line or a local generator. The BESS has thirty independently triggered inputs, which will be tied remotely to the trip circuits of breakers.

- *Scheduled load increase*: This is initiated and terminated by SCADA and puts the BESS in a frequency and voltage regulation mode to allow it to respond to the addition of large motor loads.
- *Automatic generation control*: In this mode the BESS is capable of operating by AGC, similar to that of rotating machinery.
- *Charging*: The SCADA dispatcher can control the MW rate at which the BESS will be charged and when charging is to start after a BESS discharge.

### The battery

The Alaskan BESS battery comprises 13,760 Saft SBH 920 high-performance rechargeable nickel-cadmium cells, arranged in four parallel strings to provide a nominal DC link voltage of 5000 V and a storage capacity of 3680 Ah. The cells are built into 10-cell modules for mounting in a drive-in racking system. An aisle between the racks provides installation and service access for a swing-arm fork truck.

The complete battery weighs some 1300 tons and the hall in which it is located measures 120 meters by 26 meters – about the size of a soccer field. The initial battery configuration has four individual strings operating in parallel, but can be expanded to accommodate eight strings. Each string has 3440 cells connected in series.

The battery features a pocket plate construction with thin, high-performance plates. This design allows the full 20–25 year life to be attained without any loss of the beneficial characteristics of Ni-Cd batteries. The type of cell used can deliver 80% of its rated capacity in 20 minutes.

Ni-Cd pocket plate cells can withstand repeated deep discharges with little effect on battery life. The graph in 1 shows the cycling characteristics of the SBH battery.

The chosen design has several advantages:

- *Compact arrangement*: More rack depth can be utilized, minimizing the space taken up by aisles.

1 Cycling characteristics of the BESS battery. No. of charge/discharge cycles vs depth of discharge

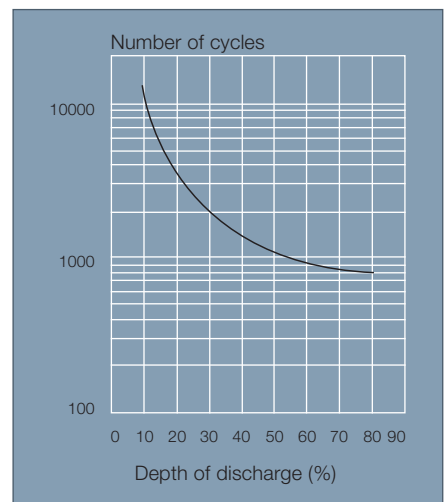

- *Easy installation*: 90% of the connections are made in the factory; only the inter-module connections are made on site.
- *Quick change-out*: If there is a problem with an individual cell, the module containing that cell can be replaced by another complete module in less than 30 minutes 2.
- *Minimum power losses*: 99% of the inter-cell connections are made with solid copper bars; power losses caused by flexible cable connections are therefore minimized.
- *Spill isolation*: The cells sit on a plastic grating, allowing spills to drain into the base of the module. The tray can hold the electrolyte content of all ten cells.

### World record

During commissioning tests, ABB's power conversion system and the Saft battery set an unofficial world record by achieving a peak discharge of 26.7 MW with just two strings in operation, making use of the short-time overload capability of the battery modules. This makes the Alaskan BESS more than 27 percent more powerful than the previous record holder – a 21-MW BESS commissioned by PREPA (Puerto Rico Electric Power Authority) at Sabana Llana, Puerto Rico in 1994.



A PE liner on the inside of the module case (between the battery cells and metal tray) provides the necessary insulation. Each module is fitted with a self-contained, single-point filling system, allowing all 10 cells to be topped up in a single operation without removing the module from the rack.

#### Battery monitoring system

The battery monitoring system was supplied by Philadelphia Scientific Inc. It measures, records and reports the module voltage, string current, cell electrolyte level (one cell per module) and cell internal temperature (also one cell per module).

Data collection and transfer are organized hierarchically. The lowest-level device in the hierarchy is the *sentry unit*. There is one for each 10-cell module, and its task is to measure the module voltage, cell electrolyte level and cell internal temperature. Each sentry unit reports its collected data to a sergeant module. Every string has its own *sergeant module*, which also measures the string float current. In turn, the sergeant module reports its collected data to the *supervisory computer*, which analyzes and displays the data. This computer is also responsible for forwarding summary data to the HMI and is the main terminal for BESS per-

sonnel who need to access the monitoring system.

Optical couplers carry the data from the sentry units to the data bus, which is insulated to withstand a minimum of 5000 V. 5560 readings are taken every 30 seconds – a total of 5.8 billion readings per year. These numbers can be doubled if required.

#### The electrical system

Four battery strings are currently installed [3](#). All preparations have been made for extension at a later stage, with up to eight battery strings possible. Every string (and sub-string) can be switched off and completely isolated from the rest of the system by DC switches. In addition, two disconnectors allow separation of the battery and the DC link of the converter when maintenance work has to be carried out on the batteries. The converter can then remain in operation and provide reactive power to the grid for voltage control. Filter circuits in the DC link eliminate the risk of resonances at higher frequencies should any harmonics be generated in the grid by non-linear loads. The voltage source converter at the heart of the electrical system comprises standardized PEBBs (Power Electronic Building Blocks). One double-stack PEBB in NPC (Neutral Point Clamped) connection forms a single-phase H-bridge [4](#). Four H-bridges are installed per phase, for a total of twelve single bridges. The stacks are cooled by deionized water in a closed-loop circuit.

Each bridge is connected to its dedicated transformer winding. The voltage contributed by the bridges is added in the transformer by series-connecting the line-side partial windings, resulting in a voltage wave shape similar to the quality that could be expected from rotating machines. Voltage limiters prevent any overvoltages due to sudden load rejections or possible disturbances in the electric grid from damaging the DC link.

The converter and transformers have been designed and built to handle the total power should the battery be extended from four to eight strings at a later stage.

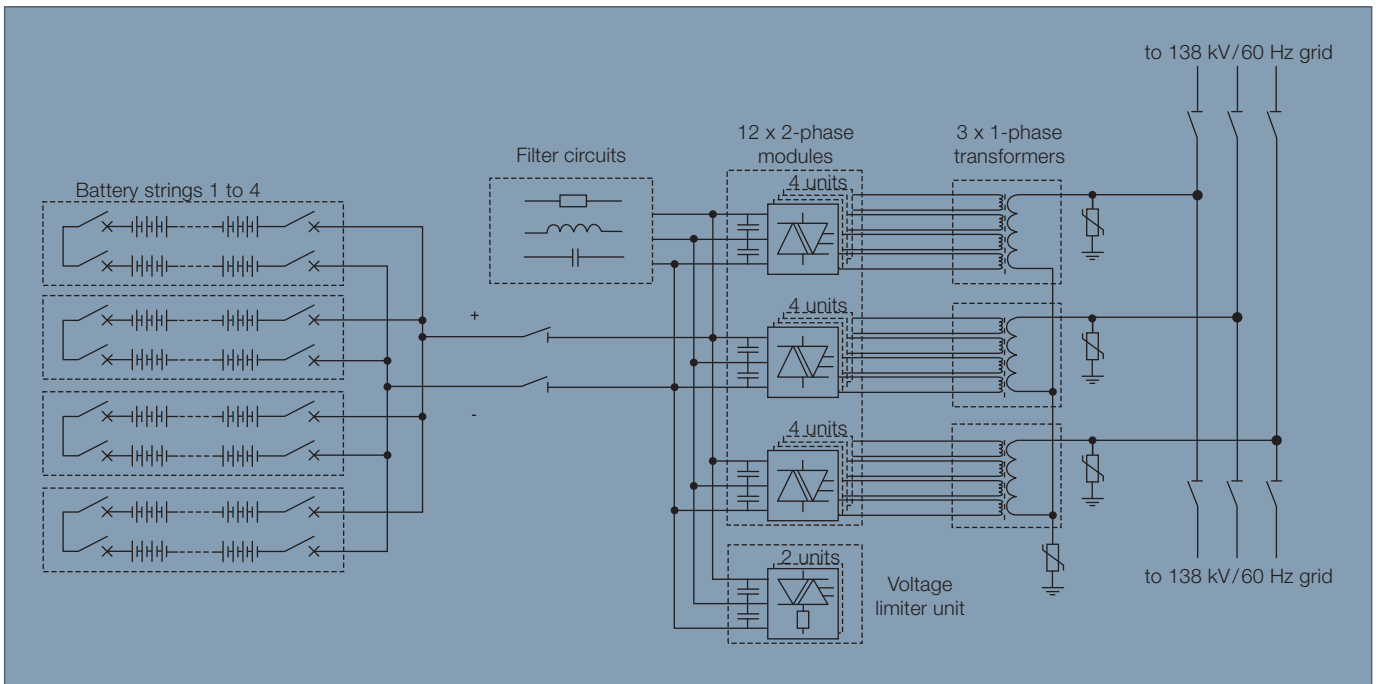

The active switching devices used in the converter are integrated gate commutated thyristors (IGCTs), an advanced type of gate turn off thyristor (GTO). Compared with other devices that can be turned off, IGCTs have the advantage of lower conduction and switching losses, plus superior switch-off characteristics that allow a snubberless converter design.

Advantages of this converter design include:

- The three-level medium-voltage modules are proven, highly reliable products. Low FIT values are obtained when these modules are used.
- Use of double-stack modules shortens the distances between the power semiconductors, keeping stray inductances low, and reduces the space required for the complete converter.
- Since the clamp diodes and capacitors are integrated in the semiconductor stack, the stray inductance in the clamp circuit is also minimized, allowing use of higher IGCT switch-off currents.
- Using a single clamp for two phases reduces the need for bulky and costly clamp inductors and resistors.

- Ease of serviceability was a primary consideration during the mechanical design. All power semiconductors in the stack are readily accessible, allowing easy replacement.

**Power and reactive power performance**

The system is designed for four-quadrant operation. It can charge as well as discharge the battery and it can absorb

Building block. A double-stack water-cooled PEBB in NPC connection, forming one H-bridge

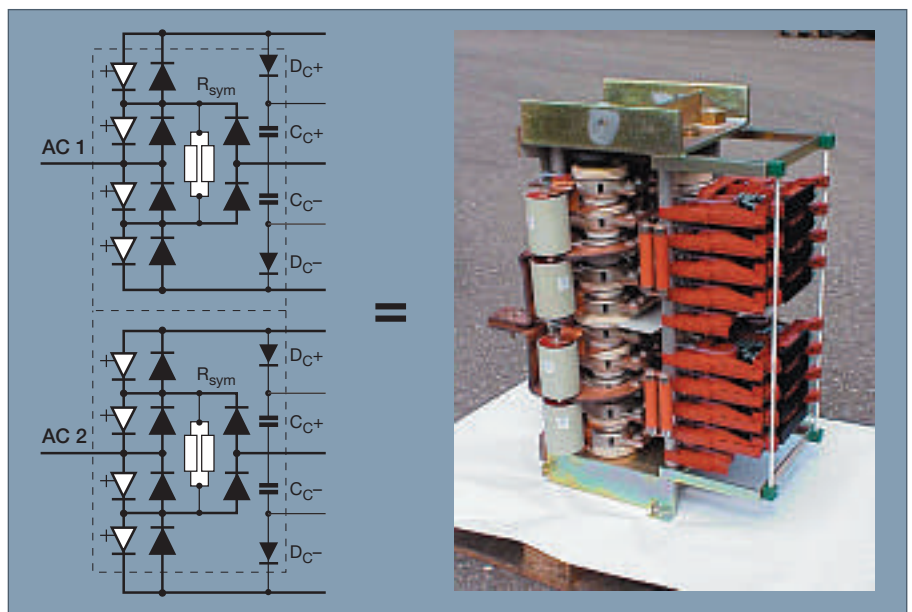

5

Operating range of BESS  
P/Q diagram  
1 pu corresponds to 40 MVA

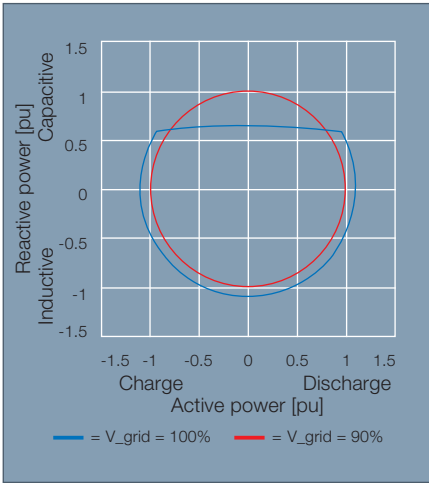

reactive power from or supply reactive power to the grid. Each of these modes is possible with the DC link voltage varying as the battery's charging condition changes.

The operating range of the system in terms of active and reactive power for 90% and 100% of the nominal grid voltage is shown in 5.

**The control system**

Local system control is provided by an ABB SPIDER MicroSCADA human machine interface (HMI) based on the Microsoft Windows operating system 4. The system is operated via pictures, windows and function keys using a mouse and a keyboard. Sequence and closed-loop control as well as overall protection are provided by ABB's programmable high-speed controller (PHSC), which can be programmed using the graphic function plan program FUPLA. The PHSC is well proven and its reliability has been shown to be suitable for both system control and protection in numerous applications.

The converter control incorporates the following functionality:

- Sequence control
- Control of the main breakers
- Signal conditioning
- Processing of measurement signals
- Fast current control for ride-through in the event of external faults
- Power and reactive power control
- Load management
- Interlocking of local control and SCADA/RTU control
- Redundant protection functions

**BESS – a stabilizing factor**

While fulfilling its overall mission of reducing power outages in the Fairbanks area, the Alaskan BESS has specific benefits in the areas of transmission and distribution, generation and strategic planning:

*Transmission and distribution* benefits include voltage regulation, first swing stability and loss reduction.

In the *generation* area the BESS offers spinning reserve, ramp-rate constraint relief, load following, black starts, load leveling, and a reduction in deferred turbine starts.

*Strategic* benefits include improved power quality, reduced demand peaks, and enhanced service reliability through reduced power supply generated outages.

The principal benefit, however, is the ability of the BESS to instantly contribute to system stability following the loss of a major transmission line or generator. The spinning reserve it provides has the potential to allow generation units to be run at lower levels or be shut down entirely, resulting in significant savings. Almost instantaneous active power is available. This is important in cases where the BESS has to ramp up before the impact of a generator loss becomes noticeable at the point of common coupling.

6

Overview of control and protection system

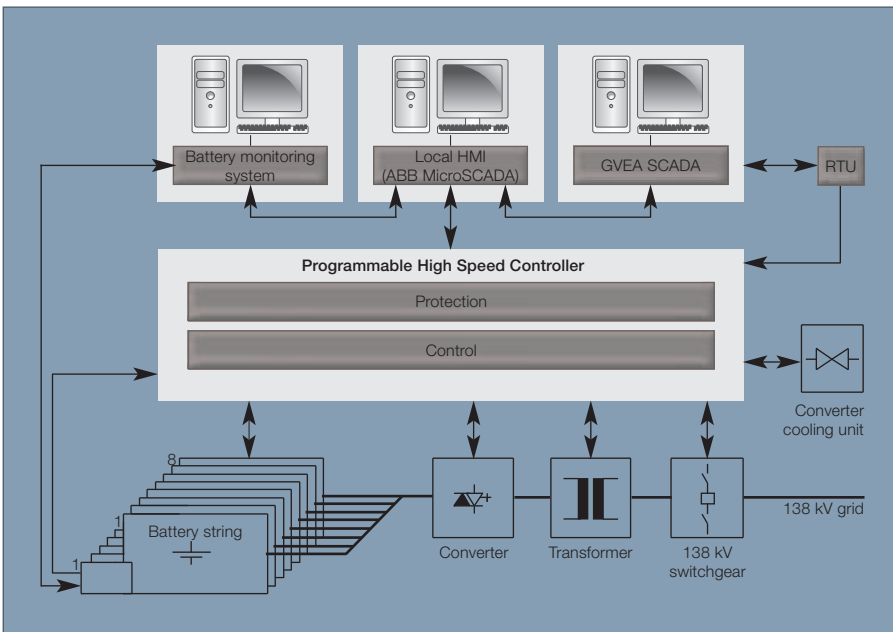

**Tim DeVries**  
Golden Valley Electric Association  
trdevries@gvea.com

**Jim McDowall**  
SAFT  
jim.mcdowall@saftamerica.com

**Niklaus Umbricht**  
**Gerhard Linhofer**  
ABB Automation Technologies  
CH-5300 Turgi  
niklaus.umbricht@ch.abb.com  
gerhard.o.linhofe@ch.abb.com

# High-voltage **XLPERFORMANCE** cable technology

Björn Dellby, Gösta Bergman, Anders Ericsson, Johan Karlstrand

**Deregulation of the electricity supply markets and growing environmental awareness are creating exciting new markets for power transmission solutions based on extruded cable technology. At the same time, improvements on all fronts are extending the use of XLPE (cross-linked polyethylene) insulated cable systems up to 500 kV. Today's cable system applications are often competitive with overhead lines, while new manufacturing methods are enabling submarine cables with integrated optical fibers and flexible joints to be supplied in longer lengths than ever before. Further development of extruded insulation systems is also contributing to the success of ABB's innovative HVDC Light™ concept.**



**H**igh-voltage cable systems rated 220 kV and above have become part of the very backbone of modern-day power transmission infrastructure. This importance carries with it, however, a special responsibility on the part of the suppliers to ensure that the systems exhibit the highest reliability and, because of the high electrical stresses at such voltage levels, that the cables and accessories are properly coordinated.

## **Deregulation – changing the rules**

In today's deregulated electricity markets, the rules that used to govern generation, transmission and distribution have changed for both the power utilities and the suppliers. Suddenly, it is the customer who is in the spotlight.

Accordingly, the market has to listen more to public opinion, and there is a strong possibility that this will include a call for a less 'visible' T&D infrastructure.

All the actors in this new market have to reduce their costs and at the same time guarantee high reliability for the transmission and distribution systems. A likely scenario is that new cable interconnections will be built and operational margins will be utilized more fully in order to get maximum technical and economic benefit from the electrical network.

Extruded cable systems have a major part to play in this new, competitive environment, especially when it comes

to replacing overhead lines with underground cables. XLPE cable systems costs have decreased during the last decade and are likely to fall even further. At the same time, XLPE cable performance has increased enormously. The new message is therefore that XLPE cable systems are able to compete with overhead lines, technically, environmentally and commercially. This is particularly true in the voltage range of 12–170 kV **1**.

## **Extruded insulation – performance and improvements**

The well-established trend toward a smaller insulation thickness will continue, resulting in a leaner cable with many advantages, among them longer dispatch lengths, fewer joints, easier

1

Comparison of cost ratio (CR) for XLPE cable systems and overhead transmission lines

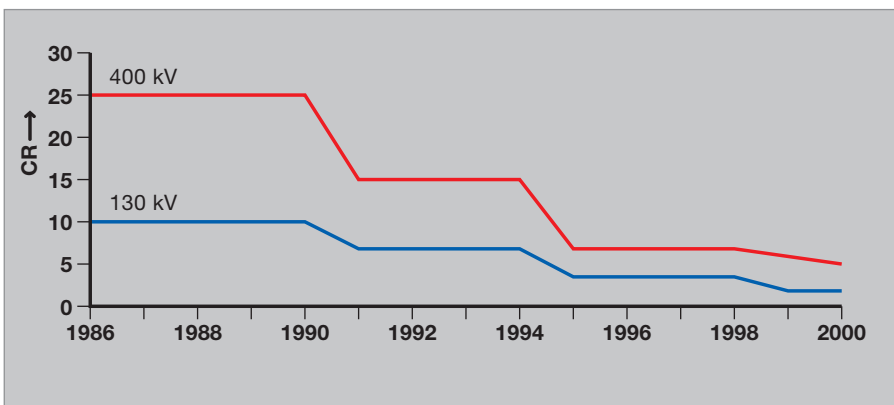

installation, and reduced thermal contraction/expansion of the insulating material. Experience accumulated during EHV XLPE cable system development, improvements made in materials and processes, and the excellent service record of XLPE, have reduced the thickness of cable insulation to 12–15 mm for 132-kV cable systems. This places the XLPE cable systems versus overhead line transmission scenario in a new light, where the cable solution often can be an attractive alternative.

### Underground cables versus overhead lines

There are, of course, many operational, security, environmental, reliability and

economic parameters that distinguish XLPE cable systems from overhead lines [1]. For modern XLPE cable systems, the reduced cost ratio and environmental and reliability benefits are the most obvious and important considerations. Due to their larger cross-sectional areas, cables usually exhibit fewer losses per MVA than comparable overhead lines. A summary of the benefits of XLPE cable systems is given in the table on page 52.

The ratings of the overhead lines are sometimes dictated by high winter loads, which include a lot of electrical heating equipment. During hot summer days the overhead line carries some

50% less electricity than in winter, making them less attractive if load profiles have to be smoothed out in the future. In areas where there are many air-conditioning units, for example, the benefits of XLPE underground cables make them a genuine alternative [2].

Underground transmission lines also have a better overload capacity for periods of time shorter than 90 minutes due to the high thermal mass of the surrounding soil.

### Qualification of 400–500 kV cable systems

The IEC emphasizes the importance of reliability and coordination of the cables and accessories by recommending that the performance of the *total system*, consisting of cable, joints and terminations, be demonstrated. The comprehensive test program, including a ‘pre-qualification’ test, is described in detail in IEC 62067.

ABB qualified as a supplier of cable systems for the 400-kV voltage level in 1995.

### Quality, materials and manufacturing

Only certified suppliers are contracted to deliver essential materials. All ABB manufacturing sites for HV cables and accessories are ISO 9001 and 14001 certified. The XLPE cable core is produced on a dry curing manufacturing line. The cable insulation system, including the conducting layers, is extruded in a single process using a triplex extrusion cross head located, together with the three extruders for the insulating and conducting materials, in a clean-room [3].

### Cable design

[4] shows a 400-kV XLPE cable. The cable’s copper conductor, which has a cross-sectional area of 2500 mm<sup>2</sup>, is divided into five segments to reduce skin effect losses. ABB uses segmented (Milliken) conductors made of stranded wires for cross-sections greater than 1000 mm<sup>2</sup>. For cross-sections smaller than 1000 mm<sup>2</sup>, the conductors are highly compacted to obtain a rounder, smoother surface.

2

Rating of overhead line (OHTL) versus underground XLPE cable. The dashed line indicates that higher powers could be transmitted if the daily load cycle profile is taken into account.

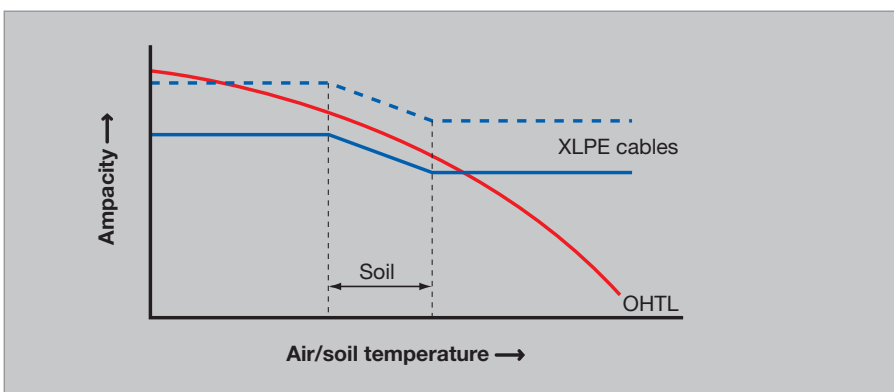



The metallic screen consists of copper wires on a bedding of crepe paper to reduce the mechanical and thermal impact transferred to the insulation. The number of wires and the total cross-section depend on the short-circuit requirements of the network. Longitudinal water tightness is achieved by filling the gaps between the screen wires with swelling powder.

External protection against mechanical impact and corrosion is provided by a tough, extruded, laminated sheath made from HDPE (high-density polyethylene). A bonded metal foil on the inside of the sheath stops water from diffusing into the cable.

The resulting lean, low-weight cable has several advantages: a greater length of cable can be wound onto any given drum; high eddy-current losses in the cable sheath are avoided; the current-carrying capacity is optimized.

Possible oversheath options are:

- An extruded conductive layer for outer sheath measurements
- An extruded flame-retardant layer for extra safety in hazardous environments

Another option the cable design offers is space-resolved temperature monitoring with optical fibers. The fibers are contained in a stainless-steel tube, approximately the same size as a screen wire, which is integrated in the cable screen. Monitoring the temperature in this way enables the cable load to be optimized.

#### Cable accessories

In the early 1990s ABB developed pre-fabricated joints for HV and EHV cables which are totally dry, ie with neither gaseous nor liquid materials, and maintenance-free. The main electrical parts can therefore be pre-tested in the factory, speeding up on-site installation and reducing the attendant risks. The joints have integrated sheath insulation in order to comply with the CIGRE recommendation contained in Electra 128, which requires them to withstand impulse voltages of 125 kV between the two joint sections and 63 kV to earth. This permits cross-bonding of the cable

3

Vertical extrusion of XLPE cable insulation

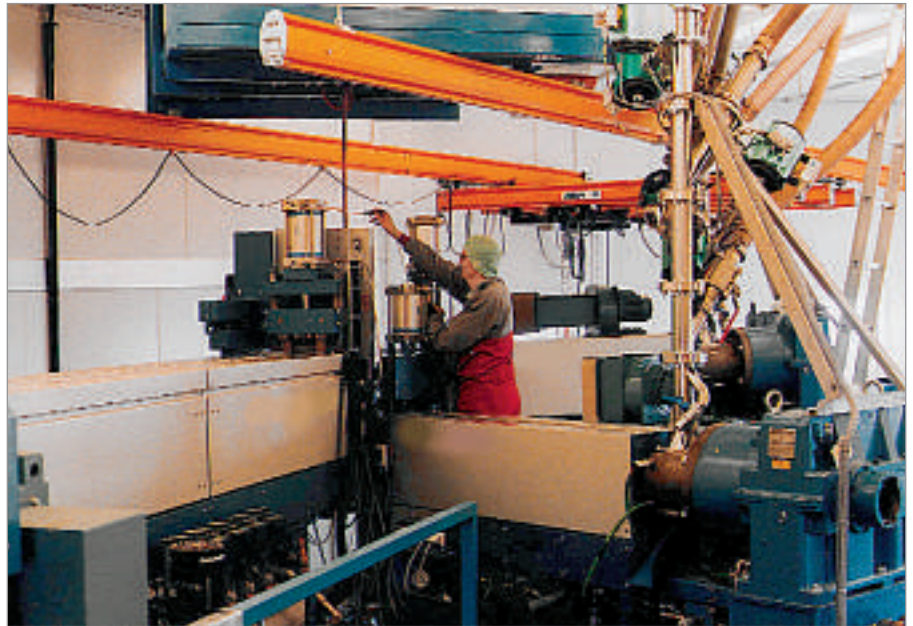

screen, which reduces the induced screen currents and losses in the AC cable system. The complete cable system with joint, outdoor terminations and GIS terminations, fulfills the requirements of IEC 62067 in every respect.

#### Testing of 220–500 kV cable systems

In the case of medium-voltage cables it is usual to think in terms of components. Even if these come from different suppliers, they can be joined together

4

400-kV XLPE cable. The copper conductor is divided into five segments to reduce skin effect losses.

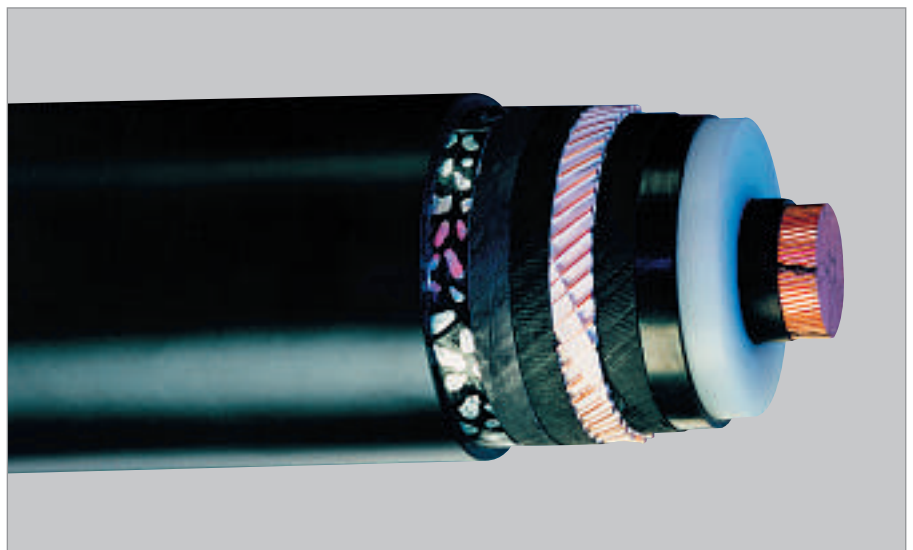

and the system as a whole will still work. This is why limits are given for the electrical stresses in the construction requirements in IEC 60502.

HV and EHV cables and accessories, on the other hand, are designed as systems. No construction requirements exist for cables for these voltage levels, just the test requirements in IEC 60840 and IEC 62067.

#### 400-kV XLPE cable projects

In 1996 ABB received an order from the public utility Bewag (now Vattenfall Europe) to supply and install a 400-kV XLPE cable system in a 6.3-km long underground tunnel in the center of Berlin. The ventilated tunnel is situated 25 to 35 meters below ground and has a diameter of 3 meters <sup>5</sup>. The cable system, with a 1600 mm<sup>2</sup> segmented copper conductor, has a transmission capacity of 1100 MVA and forms part of a diagonal transmission link between the transmission grids west and east of the capital.

The cable is installed with the three phases arranged vertically, one above the other, on specially designed cable saddle supports

7.2 meters apart, with a short circuit-proof spacer in the middle of each span. The cable route was divided into nine sections, each

approximately 730 meters long. GIS terminations were installed at the two substations and the new ABB joint was used to interconnect the cable lengths. The laid cable consists of three main cross-bonded sections, with three minor sections within each main section. The cable circuit went into service in December 1998.

The Bewag utility subsequently awarded a second 400-kV XLPE cable con-

Greater lengths of low-weight XLPE cable can be wound onto any given drum, while high eddy-current losses in the sheath are avoided.

tract to ABB, this time for a 5.4-km long system, again in an underground tunnel. This cable circuit completes the diagonal link between the transmission grids west and east of Berlin, and was handed over to the customer in July 2000.

Further 345–400 kV cable projects awarded to ABB

include orders for 200-km XLPE cables, accessories and installation. Commissioning of these projects is scheduled to take place during 2003–2004.

#### New submarine cable projects

In 1998 ABB was awarded the Channel Islands Electricity Grid Project, which reinforces the power supply from France to Jersey and, for the first time, connects Guernsey to the European mainland grid. The submarine part

5

400-kV cable system in a 6.3 km underground tunnel running through Berlin's city center



of this project was completed in July 2000.

The main components delivered for the project were:

- Submarine cables between France and Jersey and between Jersey and Guernsey (approx 70 km)
- Underground cables on Jersey and Guernsey
- GIS substations
- New transformers and reactors

The two submarine cables are of the same basic design, ie three-core, separate lead-sheathed, and with triple-extruded XLPE insulation. Each has a fiber optic cable with 24 fibers integrated in it for system communication and inter-tripping. The cables have double wire armor (ie, an inner layer of tensile armor and an outer, so-called rock armor) to protect them from damage that could be caused by tidal currents and fishing.

The cables have a diameter of approximately 250 mm and weigh about 85 kg/m in air.

Both cables were delivered by the factory in their full lengths <sup>6</sup>.

Because of the risks posed by fishing activities, the cables between Jersey and Guernsey and the fiber optic cables between Jersey and France were jettied into the seabed for extra protection.

Another submarine cable project is the Ma Wan and Kap Shui Mun Cable, which crosses a channel in Hong Kong. Due to the heavy traffic in this channel, it was decided to forgo conventional installation of the 132-kV and 11-kV systems, which would probably have disturbed shipping even if modern techniques were used. The problem was solved by drilling under the seabed and installing ducts through which the cables were pulled. This has the extra advantage of allowing upgrades to be carried out in the future.

Separate control systems were installed to monitor operation of the cable link, which was completed in 2003.

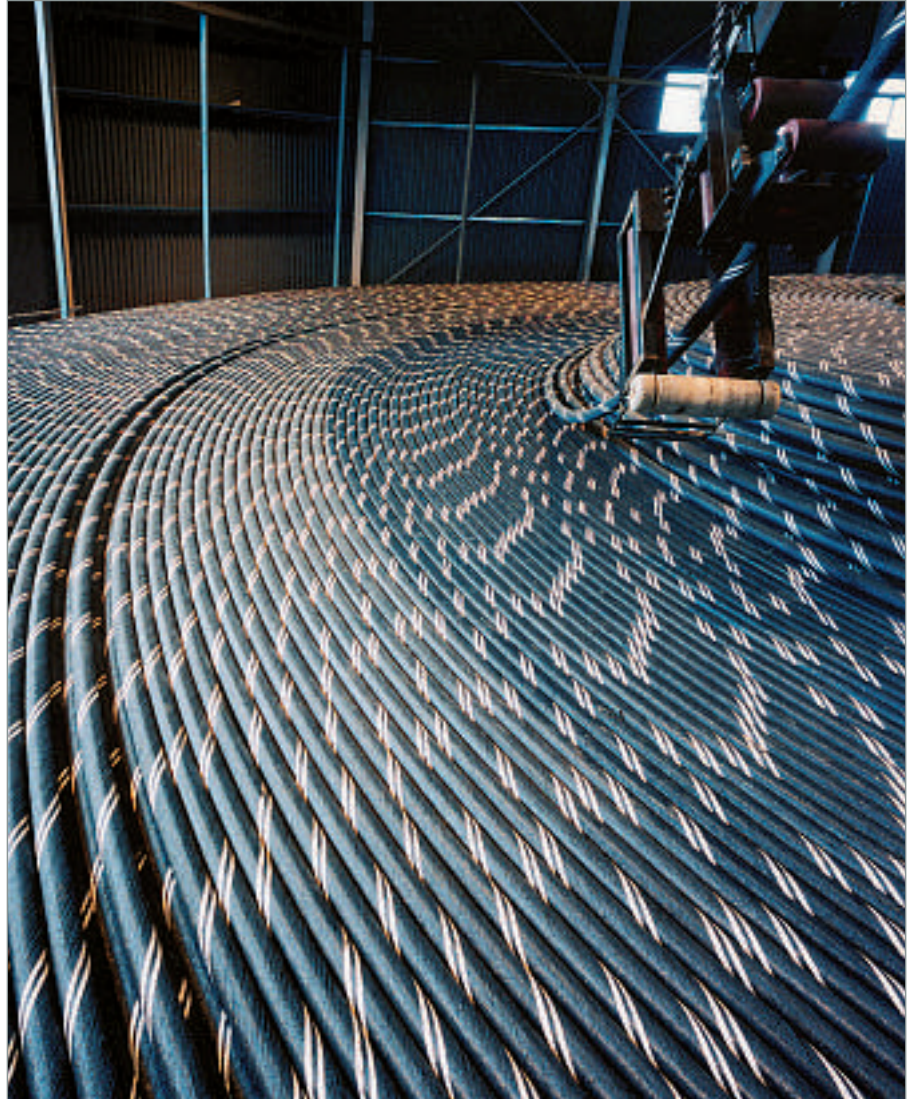

A new submarine cable project has recently been awarded to ABB by Aramco. The cable, which is 53 km long, is rated 110 kV with  $3 \times 500 \text{ mm}^2$  copper conductors. It will be commissioned in 2004.

#### HVDC Light™

HVDC Light™, which was launched in 1997, is another ABB innovation in the T&D field that incorporates advanced HV cable technology. High Voltage Direct Current (HVDC) cables are employed for bulk power transportation over long distances, mainly underwater.

Traditional cable technology is based on paper insulation systems impregnated with highly viscous oil. While these cables have many technical advantages, the manufacturing process is slow and the end-product is mechanically sensitive. The industry had therefore been looking for a long time for an extruded HVDC cable of the kind used in AC systems.

With HVDC Light [2], ABB has introduced to the market an extruded cable system, together with new transistor-based converters, that makes HVDC

Environment	Grid security	Economy	Operation
No visual impact	Not affected by wind, snow, ice, fog, etc	Low maintenance	High availability, few faults
Low/no electromagnetic fields	Nothing can be stolen	Minimum investment for lake/river crossings	Usually low losses/MVA
High level of personnel safety, low risk of flashover in air		Land use minimized	High short-time overload capacity
Good working conditions		Value of land/buildings unaffected	

Benefits of underground transmission lines

transmission competitive even at low power ratings. The first commercial system, a link rated at 50 MW, was installed on the Swedish Island of Gotland, where it transmits power from a wind power plant to the town of Visby [3].

Other major projects that have been completed are:

- The Directlink, rated 180 MW at 80 kV, which transfers power between the states of New South Wales and Queensland in Australia.
- The Murraylink, rated 200 MW at 150 kV, built to transfer power between Victoria and South Australia [4].
- The Cross Sound Cable, rated 330 MW at 150 kV, which transfers power between New England and Long Island.

The latest HVDC Light project, to supply power to an offshore platform in the North Sea (Troll A), is due to be commissioned in 2004. (See article starting on page 53.)

Applications for HVDC Light include:

- Feeding of isolated loads (eg, offshore platforms)
- Asynchronous AC grid connection

- Transmission of power from small generation units (eg, wind power plants)
- DC grids with multiple connection points
- Network reliability enhancement through voltage stability and black starts

#### Tomorrow's electrical infrastructure – here now

Extruded cable systems are available as total solutions, with a 'cradle to grave' supplier commitment. Such systems are turnkey offerings in the commercial as well as the technical sense. They may start with the permit application, continue with the removal of the overhead lines and the supply and installation of the cable system, and end with the environmentally friendly disposal of the old equipment.

Complete cable system applications can also be seen as intelligent combinations of monitoring equipment, converters, load-sharing devices, series and/or shunt compensation devices. Financing, too, can be arranged; here, leasing and a new type of availability guarantee could resolve several commercial uncertainties.

Together, these 'thumbnail' sketches of the future add up to a new customer-value-based market. Extruded insulated cable system applications are destined to play a key role in this evolving market by meeting not only the transmission and distribution network requirements of today but also those of tomorrow.

**Dr. Björn Dellby**  
**Gösta Bergman**  
**Dr. Anders Ericsson**  
**Johan P. Karlstrand**  
 ABB Power Technologies  
 High Voltage Cables  
 SE-371 23 Karlskrona  
 Sweden  
 bjorn.dellby@se.abb.com

#### References

- [1] **D. Karlsson:** Comparison of 130 kV XLPE cable systems and OH lines – loading capability, reliability and planning criteria. CIGRÉ 2002.
- [2] **K. Eriksson:** HVDC Light DC transmission based on voltage sourced converters. ABB Review 1/98, 4–9.
- [3] **M Byggeth, et al:** The development of an extruded HVDC cable system and its first application in the Gotland HVDC Light project. JICABLE 1999.
- [4] **T. Worzyk, et al:** The Murraylink Project – the first commercial 150 kV extruded HVDC cable system, JICABLE 2003.

# Powering Troll

## with HVDC Light™

Tom F. Nestli, Lars Stendus, Magnus J. Johansson, Arne Abrahamsson, Philip C. Kjaer

With its compressors, motors and electrical systems devouring many tens of megawatts, an offshore installation can be a power-hungry beast indeed. The onboard gas turbines or diesel generators that usually supply this power, however, manage no more than about 25% efficiency – way off the dazzling 75–80% efficiencies of, say, land-based combined cycle power plants. This inefficiency isn't just costly in terms of excessive fuel consumption, either; high emissions can rack up the cost still further, for example where CO<sub>2</sub> taxation applies.

Now, new technologies from ABB are making it easier than ever before to deliver electrical power to offshore installations, lowering operating costs and reducing environmental impact at the same time. Seventy kilometers off the Norwegian coast, two of these technologies – HVDC Light™ and Motorformer™ – are helping to power 40-MW compressor units on Statoil's Troll A platform without any local power generation.

Troll A platform (Photo: Øyvind Hagen, Statoil)

On most offshore installations, the power generators and large compressors are driven by onboard gas turbines or diesel engines with total efficiencies that can be as low as 20–25 % even under ideal conditions. As a result, fuel consumption and CO<sub>2</sub> emissions are unnecessarily high. Ever since the Kyoto Protocol, which allows trading of greenhouse gas emissions, high CO<sub>2</sub> emissions have become a cost factor. On top of this, as on the Norwegian shelf, there may be CO<sub>2</sub> taxation, making emissions costly even without trading.

If the electrical power for all this equipment can be supplied from shore, the CO<sub>2</sub> emissions of offshore installations are eliminated, saving operators a considerable sum of money. But that isn't all; transmitting electrical energy from shore is also more efficient in terms of equipment maintenance, lifetime and availability.

The overall environmental bonus of eliminating low-efficiency offshore power plants is considerable. A land-based combined cycle gas power plant, which utilizes the gas turbine's waste heat, can have an efficiency of as much as 75 to 80%. Even if high losses of 10% are assumed for a long transmission line to an offshore installation, the saving will still be significant for most installations.

### HVDC Light™ and Motorformer™ join the offshore club

Troll A is the largest gas production platform on the Norwegian shelf. Some 40% of Norway's total annual gas production comes from Troll A, which can produce up to 100 million cubic meters of gas per day. Today, the reservoir pressure drives the gas to the onshore processing plant at Kollsnes, where the condensate, water and gas are separated. The gas is then compressed and transported through pipelines to the European continent [1].

As the gas is taken out of the reservoir, the pressure inevitably decreases. This means that to maintain production capacity, offshore precompression of the gas will eventually become necessary. ABB has been awarded two contracts as part of Statoil's Troll A Precompression Project: a US\$ 185 million contract for the compression equipment and a US\$ 85 million contract for the electric drive systems for compressors. The new installation is due to go into commercial operation in the fall of 2005 as part of a program introduced to maintain and expand the platform's production capacity.

Choosing conventional systems for this project would have meant that gas turbines would drive the compressors. In that case, it is estimated, annual emis-

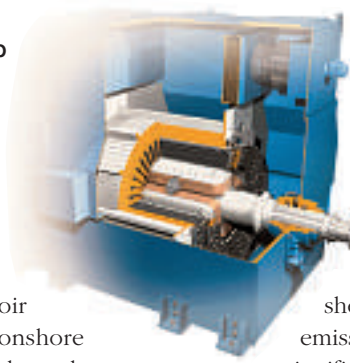

sions of some 230,000 tons of CO<sub>2</sub> and 230 tons of NO<sub>x</sub> would result. Besides their impact on the environment, the CO<sub>2</sub> taxation in effect on the Norwegian shelf means that such emissions would also be a significant cost factor.

Working with Statoil, ABB developed an alternative system [2] based on two innovative ABB technologies – HVDC Light™ and Motorformer™. These have been successfully employed on shore since 1997 and 1998, respectively, but never before on an offshore installation or together as an electric drive system. The system uses power from the onshore electrical grid to drive the compressors on Troll A, thus eliminating greenhouse gas emissions from the platform.

### HVDC Light – rectifying, inverting and controlling

HVDC Light [1], by using series-connected power transistors, enables voltage source converters to be connected to networks at voltage levels higher than ever before for power transmission, reactive power compensation and harmonic/flicker compensation.

On Troll A, an HVDC Light converter (inverter) feeds the variable-speed synchronous machine driving each compressor with AC power obtained by converting the incoming DC, which is transmitted from shore over submarine cables. As their speed is variable, the compressors are supplied with power at variable frequency and voltage, right through from zero to maximum speed (at 63 Hz) and from zero to maximum voltage (56 kV), including starting, acceleration and braking. The drive systems perform equally well at each end of the frequency spectrum. Small filters at the converters' outputs keep the motor winding stress at a safe level.

The inverter control software is adapted for both motor speed and torque control. The motor currents and voltages and the rotor position are measured and

1

Gas from Troll A is processed at Kollsnes before being transported to the European continent.



From the rectifier station at Kollsnes, subsea HVDC cables transmit power to the Troll A Platform, where the inverter station and Motorformer™ are located. Two identical systems are to be installed.

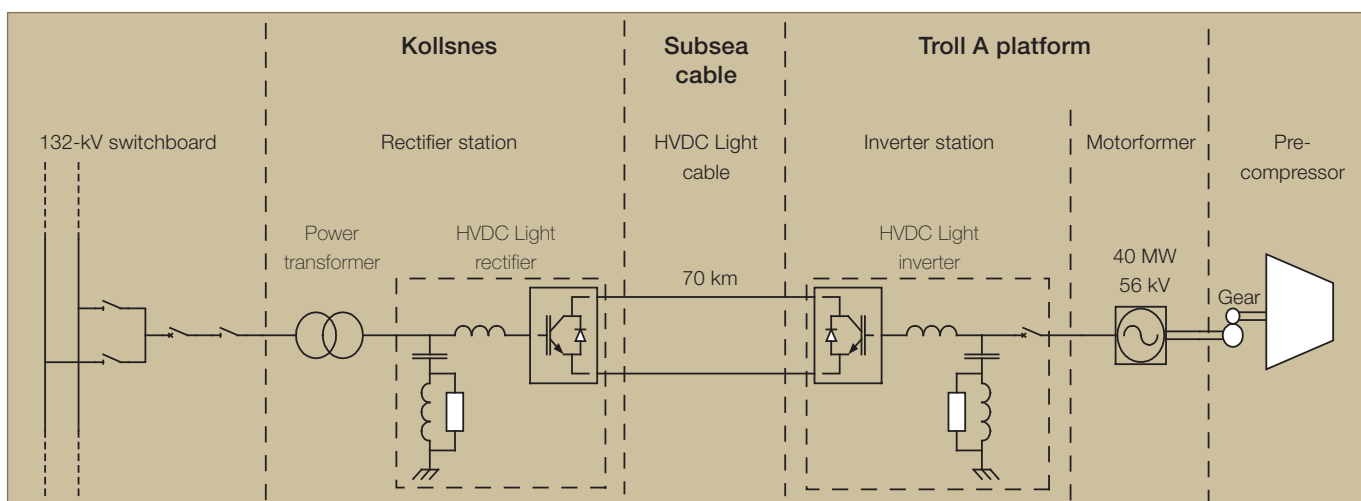

used together with an advanced model of the machine's electromagnetic parameters to calculate converter switching pulses in much the same way as for smaller industrial variable-speed drives (ACS 600/ACS 1000/ACS 6000). Unity power factor and low harmonics are assured, along with a sufficiently high dynamic response, over the motor's entire operating range. Protection and monitoring of the converters and synchronous machines, as well as control of the excitation converter feeding the latters' field winding, are handled by ABB's well-proven Industrial<sup>IT</sup> HVDC Control, MACH 2.

Overall control of the rectifier station at Kollsnes is also handled by the MACH 2.

There is no need for communication between the rectifier control system on land and the motor control system on the platform; the only quantity that can be detected at each end of the transmission system is the DC link voltage. As the DC link cannot store much energy, the motor control system is designed to follow even rapid changes in power flow at the opposite end without disturbing motor operation. Nuisance tripping is generally kept to a minimum.

The HVDC Light converter for Troll is based on a two-level bridge with grounded midpoint. Only extremely low ground currents are induced during steady state and dynamic operation, this feature being one of the main reasons for using HVDC for the power supply. No cathode protection of any kind has to be provided for this installation.

#### HVDC Light cable – the power carrier

The HVDC Light concept includes a further innovation: the HVDC Light extruded polymer cable. The shift in high-voltage AC technology from paper-insulated to extruded polymer cable was the incentive for ABB to develop and produce an extruded cable offering the same benefits – flexibility and cost-effectiveness – for HVDC transmission.

Troll A's importance as a major gas producer called for an extremely reliable transmission link. The actual cable has a 300-mm<sup>2</sup> copper conductor surrounded by a very strong and robust polymeric insulating material [1]. Water ingress is prevented by a seamless layer of extruded lead, over which there are two layers of armor – steel wire woven in counter helix – to provide the required mechanical properties. This design ensures that the cable has the strength and flexibility necessary for laying in the North Sea. The two electric drive systems require an HVDC Light cable system with two cable pairs

#### HVDC Light

In the past, high-voltage DC links have been used almost exclusively to transmit very high powers over long distances. HVDC Light [1] is a new transmission technology based on voltage source converters that extends the economical power range of HVDC transmission down to just a few megawatts.

HVDC Light also offers power quality improvements, for example reactive power compensation and harmonic/flicker compensation. Thanks to fast vector control, active and reactive power can be controlled independently, with harmonics kept low, even in weak grids.

#### Motorformer

Motorformer [2] features conventional rotor, exciter, control and protection technologies. Most of the stator technology is also conventional – the exception is the winding, which is made of XLPE-insulated cable. The stator's cable slots are designed for low electrical losses, high-strength cable clamping, efficient cooling and simple installation.

The first Motorformer to go into commercial operation, at the AGA plant in Sweden, has verified the many benefits of using HV cable technology in large electric motors. Motorformer is suitable for most applications where conventional technology is used today.

3

HVDC Light™ extruded submarine cable, with double armoring (80 kV rating)



(one for each drive), physically separated from each other on the sea floor. The two cables in each pair are operated in bipolar mode, one having a positive and the other a negative polarity.

To make sure that the cables will not be damaged by anchors or trawling, they are laid in trenches on the sea bed formed by water jetting, or covered with rocks where this is not practicable.

### Motorformer™ drives the compressors

Following the introduction in 1998 of new, innovative cable winding technology, ABB's engineers soon began to consider the possibility of using HV



cable windings in place of conventional windings in electrical motors in order to radically increase the motors' voltage ratings. Such a motor can then be connected directly to the HV grid, doing away with the need for a costly step-down transformer.

The first product to be based on this principle was an HV cable-wound generator. Shortly afterwards, the same concept was applied to motors, resulting in the development of a synchronous machine, dubbed Motorformer™ (see panel on page 55). The first unit was installed in 2001 at an air separation plant in Sweden, where it drives a compressor. This motor is directly connected to a 42-kV bus. In the meantime, ABB offers HV motors of this kind for voltages up to 70 kV. Work is currently under way to develop units rated at 150 kV.

Apart from eliminating the step-down transformer and related switchgear, Motorformer reduces the total system losses by as much as 25% [1]. Being epoxy-free, it also has important environmental benefits, including easy recyclability. And fewer components mean higher system reliability and availability, plus reduced costs for service, maintenance and spares.

### A challenging environment for high-voltage equipment

Offshore equipment design is constrained by the need to keep both footprint and weight to a minimum. HVDC Light and Motorformer offer important advantages in precisely these areas:

- Smaller filters and the absence of synchronous condensers make HVDC Light more compact and lighter than traditional HVDC systems.
- No large, heavy transformer is required to connect the Motorformer to the HVDC Light converter.

Other design considerations in connection with this project were:

- Safety: Troll A produces large quantities of hydrocarbon gas, which is not

4

Use of Motorformer™ eliminates transformer losses (A). Only motor losses (B) remain.

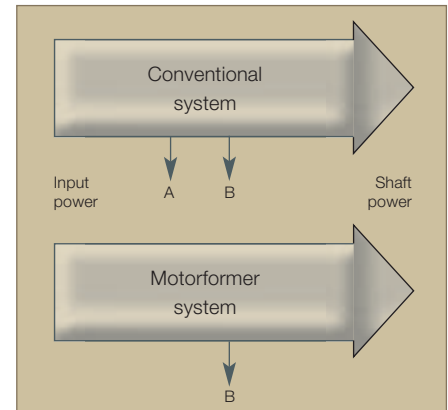

allowed to come into contact with high-voltage equipment.

- Environment: The high-voltage equipment must be protected from the damp, salt-laden sea air.
- Availability: Given the daily production of gas worth US\$ 10–15 million, high equipment availability is essential.

HVDC Light and Motorformer are innovative technologies with all the qualities needed to power offshore platforms from shore for maximum economical and environmental benefit. Troll A is the first such platform anywhere to be powered in this way, the electric drive system being part of a program to maintain and expand production capacity. The elimination of CO<sub>2</sub> emissions and a smaller equipment footprint are just two of the benefits enjoyed by Statoil as a result.

Dr. Tom F. Nestli  
Magnus J. Johansson  
ABB Automation Technologies  
tom.f.nestli@no.abb.com

Lars Stendus  
Arne Abrahamsson  
Dr. Philip C. Kjaer  
ABB Power Technologies

[1] G. Asplund, K. Eriksson, K. Svensson: HVDC Light – DC transmission based on voltage sourced converters. ABB Review 1/1998, 4–9.

[2] G. L. Eriksson: Motorformer – A new motor for direct HV connection. ABB Review 1/2001, 22–25.



# SwePol Link

## sets new environmental standard for HVDC transmission

Leif Söderberg, Bernt Abrahamsson



**Six cable links – all of them HVDC (high-voltage direct current) – are currently in service between the power grids of continental Europe and the Nordic region, with another five planned. The latest to be brought on line is the SwePol Link, which connects the electricity networks of Poland and Sweden. It is unique in that, unlike previous installations that depend on electrode stations to transmit the return current under ground or under water, it uses cables to carry this current.**

The reason for all these links is the vital need to secure power system reliability in each of the participating countries. They make it easier to optimize power generation in an area in which different countries use different means of power generation and have different power demand profiles over a 24-hour period. Wet summers in the Nordic region result in a considerable power surplus, which can be sold to countries that rely on more expensive fossil fuel-fired power plants. Conversely, any surplus power can be sold back during periods of low load.

Power system reliability in the region is increased by the addition of new HVDC cable links. In the event of grid disruptions, the rapid power balancing ability of these links can be used to compensate for fluctuations in frequency and voltage. For example, it is technically feasible to reverse the entire 600 MW power throughput of the SwePol Link in just 1.3 seconds, although this is not a feature that will be used in practice. Nevertheless, a typical emergency power measure could call for a  $\Delta P$  ramp-up of

300 MW within a few seconds to prevent grid failure if the voltage in southern Sweden drops below 380 kV.

All previous links of this kind use electrode stations off the coast to transmit the return current under the sea, and this has worked perfectly well. The first such cable link was laid in 1954 between Västervik, on the Swedish mainland, and the Baltic island of Gotland. Since then, the power rating has been increased and the original mercury arc valves in the converter stations have been replaced with thyristor valves.

In the case of the SwePol Link, return cables were chosen as an alternative to electrodes in order to pacify local resistance to the project, particularly around Karlshamn. The environmental issues that were raised during planning of this link may also apply to future installations.

### **Lower emissions benefit the environment**

The power link between Sweden and Poland is the latest example of the

growing economic cooperation between the countries bordering the Baltic Sea. The cable, which was taken into commercial service in June 2000, is a step toward the large-scale power distribution partnership that is known as the Baltic Ring [1].

The new link allows power generation to be stabilized in both countries, where the seasonal and daily variations in demand can differ considerably. The surplus that builds up in the Nordic region during wet years has already been mentioned. In a really cold year it makes financial sense for this region to import Polish electricity generated from coal rather than start up a condensing oil-fired power plant or a gas turbine.

Polish imports of electricity via the link will in turn reduce environmental impact in that country. The predicted annual net import of 1.7 TWh is expected to reduce emissions from Polish power plants by 170,000 tonnes of sulfur dioxide and 1.7 million tonnes of carbon dioxide, according to calculations by the Swedish power company Vattenfall.

**1** SwePol Link between Sweden and Poland.

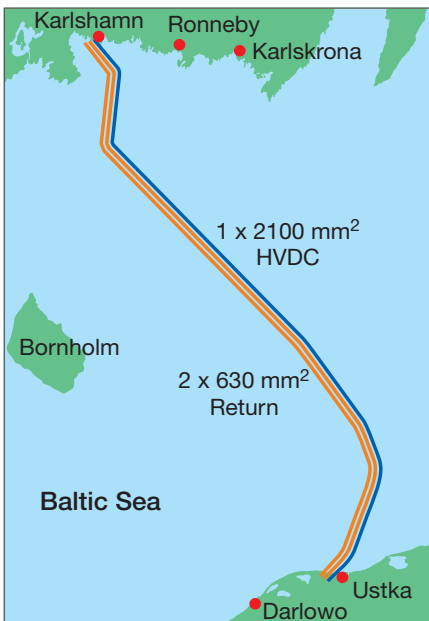

The power cable (blue) and the return cables (red) run on the same route, spaced 5 to 10 m apart in shallow water and 20 to 40 m apart in deep water.

Poland's forthcoming admission to the EU will reinforce measures to reduce its environmental impact, thereby promoting the import of Swedish hydropower.

**2** The 250-km SwePol Link exchanges power between 400-kV AC grids in Sweden and Poland.



The converter stations are near Karlshamn in southern Sweden and at Slupsk, 12 km from the Polish coast.

**Cable company is set up**

SwePol Link AB was formed in 1997 to install, own and operate the cable link between Sweden and Poland. It is a power transmission company that will sell electricity transmission services across the link.

A Polish subsidiary was formed in 1998 to handle the local business. On the Swedish side the link will be used primarily by state-owned Vattenfall, although other companies will be able to sign transmission agreements with SwePol Link.

The new link is approximately 250 km long. It runs from Stårnö, just outside Karlshamn in Sweden, past the Danish island of Bornholm, and returns to land at the seaside resort of Ustka on the Baltic coast of Poland 1, 2.

The Swedish converter station was sited at Stårnö because a 400-kV station and the Swedish main grid are nearby. This avoided having to build new overhead lines that would have marred the Swedish countryside. The Polish converter station 3 is connected to the Polish 400-kV grid at Slupsk, about 12 km from the coast.

The link involved around 2500 man-years of work for ABB, primarily at its plants in Ludvika and Karlskrona. Both stations are unmanned, although on-call personnel will be able to provide coverage at short notice.

**DC circuit**

The land-based power grid is, of course, an AC system. However, for long underwater links DC is the only viable solution on account of the high capacitance of submarine cables.

Most cable links are monopolar systems, in which the return current is carried through the ground and the sea. Power is transmitted over a high-voltage cable. It is a common misconception that sea-water carries the return current because of its high conductivity. However, most of the current travels at a considerable depth through the earth.

In the case of the SwePol Link the return current is carried by two insulated copper conductors rated at 20 kV. The use of these conductors eliminates the need for environmentally controversial electrodes.

The high-voltage cable 4 is around 140 mm in diameter, of which the central conductor takes up 53 mm. Instead of being solid, this consists of copper segments to make it more flexible. The segments are shaped individually, then rolled as a unit to achieve an effective copper cross-section in excess of 99%. The rest of the cable consists of various layers of insulation, sealant and armor. The 250-km long cable is made up of four sections which are laid individually and joined by the laying barge.

**Visible parts of the link**

The visible parts of the link are the two converter stations at Stårnö and Slupsk. Located just a small distance from the center of Karlshamn, the Stårnö station is next to an oil-fired power plant that completely dominates the landscape. By siting the tall valve building in a former quarry some 10 meters deep, the station's impact on the skyline is reduced even more. The power cables run 2.3 km from the station to the sea.

At the Polish end, the valve building is a prominent, but by no means ugly, landmark in the flat agricultural countryside. The Slupsk station is just over 20 meters high and is situated about 12 km from the Polish coast.

Both the high-voltage and return cables run underground almost all the way between the stations. On land this required clearing a five-meter wide swathe through the landscape when the cables were being laid. This will soon be hidden, partly thanks to forest replanting. At sea about 85% of the cable could be laid in a trench about one meter deep to avoid damage by trawlers and anchors.

The converter stations cannot only be seen, but heard too. This is because the



eddy currents that flow in all power transformers generate noise at a frequency of 100 Hz. Converter stations also produce higher-frequency noise that can be irritating to people living nearby. It was clear that special sound-proofing would be necessary. Following calculations and measurement of the noise level and noise propagation, the transformers and reactors were enclosed. The filter capacitor cans are equipped with a noise-reducing device.

#### A magnetic field with minimal effect on the surroundings

Whenever electricity is transmitted through a conductor it generates a magnetic field around it. Since DC is used, the field is of the same type as the earth's natural magnetic field. This is completely different to the AC fields normally produced, for example, around overhead lines.

Measurements have shown that the magnetic field around the cable at a distance of six meters is equal in strength to the earth's natural magnetic field, while at a distance of 60 meters its intensity drops to just one tenth of that field.

The magnetic field resulting from the combination of 1 + 2 cables varies with the depth and relative spacing of the cables. It is not practicable to lay the

high-voltage cable at the same time as the two return cables, which means that they cannot be laid right next to each other. They also have to be separated because of the heat they generate. In shallow water the HV cable is laid 5–10 meters from the return cables. The resulting magnetic field measured on the surface of the sea is typically 80% of that obtained around a high-voltage cable in a monopolar installation. The equivalent figure at 100 meters depth with 20–40 meters separation is typically 50%.

Further away from the cables there is an even greater percentage reduction in the magnetic field, added to the fact that the absolute value of the magnetic field at this distance is insignificant compared with the earth's magnetic field. Thus, the use of return cables has no major effect on magnetic field strength. And, anyway, modern ships no longer depend on magnetic compasses.

But what are the possible effects on animal life? Experience with previous cable links has shown that they do not affect fish or other marine organisms. Nor do they affect the vital homing ability of eels and salmon. This is especially important since these fish migrate regularly during the course

of their lives and it is essential that their sense of direction remain unimpaired.

Back in 1959 a study was carried out to determine how the Gotland cable had affected the marine environment [2]. This was followed by exhaustive studies on the Fenno-Skan link (Sweden–Finland) and the Baltic Cable (Sweden–Germany) [3]. The reports were unanimous: marine life is affected neither by the magnetic field nor by any chemical reactions. The facts speak for themselves. Eels continue to find their way to the Baltic Sea, despite having to cross seven cables on the way [4, 5].

#### No chlorine formation

The originally proposed monopolar solution, which would have used electrodes to transmit the return current undersea, has been replaced by an alternative solution in which return cables form a closed circuit. Any concerns about chlorine formation have therefore been entirely eliminated, since no electrolysis can occur.

4

SwePol Link power cable, rated 600 MW and 450 kV DC. Its overload capacity is 720 MW at temperatures below 20°C.

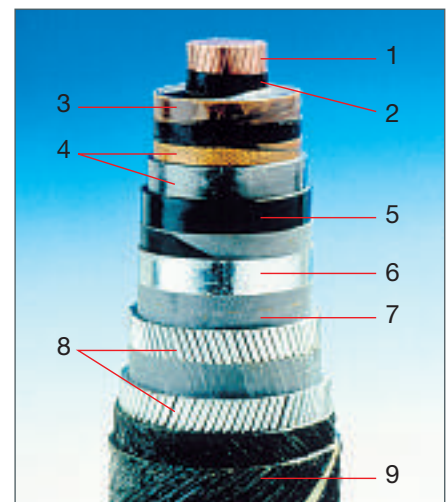

- |                     |                      |
|---------------------|----------------------|
| 1 Conductor         | 6 Protection/bedding |
| 2 Conductor screen  | 7 Reinforcement      |
| 3 Insulation        | 8 Armor              |
| 4 Insulation screen | 9 Serving            |
| 5 Metal sheath      |                      |

### Metal objects on Swedish coast that could have been affected by the SwePol Link

Object length	Distance from electrode	Example
More than 25 m	Less than 5 km	Cable support
More than 200 m	5 – 10 km	Sewage pipe Ø 1.2 m
More than 1000 m	10 – 20 km	10-kV cable District heating Copper shield around building
More than 5000 m	20 – 50 km	Protective shield (Cu)

The electrodes that would have been used have an anode made of fine titanium mesh and copper cables for the cathode. The following competing reactions take place at the anode:

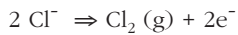
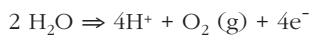

(g) in the above formulae indicates that these elements are in gaseous form.

The amount of chlorine gas generated depends on the temperature, the chloride content of the seawater and the reaction energies. It reacts almost exclusively with water as follows:

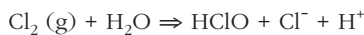

At low pH the hypochlorous acid that is formed could be ionized, but in seawater it mostly occurs in molecular form. In time it breaks down into its component parts.

There was a suspicion that the chlorine gas and hypochlorous acid that are formed would react with biological material in the vicinity of the electrodes, resulting in the formation of compounds such as polychlorinated hydrocarbons, which include PCBs. Studies on the Baltic Cable

have ruled out this concern [3]. No accumulation of organic chlorine was observed in the surrounding biomass.

To put things in the right perspective it is worth comparing the described process with the common chlorination of drinking water, in which the hypochlorite concentration is at least 100 times higher than the value measured at the anode.

#### No corrosion

The return cables used for the SwePol Link eliminate the risk of corrosion, and this would seem to be the only tangible advantage they offer.

DC cable links that use electrodes do lead to leakage currents in the earth. The return current passing through the earth takes the shortest path. On its route between the electrodes some of the current may pass through long metal objects, such as railway tracks, gas pipes and cable shielding. Electrolytic reactions could occur between this metal and its surroundings, possibly leading to corrosion. During the planning of the SwePol Link a list was therefore made of all the metal objects that could be at risk (see table).

Objects that are at risk of corrosion due to leakage currents require some form

of active protection, such as sacrificial or cathodic protection.

The return current can also find a route through other power distribution systems that have multiple earth points close to the electrode. This gives rise to a DC component in the AC grid, which can lead to undesirable DC magnetization of transformers. The problem can generally be solved by modifying the grounding of the AC system.

#### Benefits versus cost

Using the described return cables does, of course, have some advantages, among them the reduced magnetic field strength along the cable route and the fact that they cause neither chlorine formation nor corrosion of underground metal objects. And they also allowed a solution that addressed the environmental concerns of various groups of society. In any final count, however, these benefits have to be measured against the extra cost. In the case of the SwePol Link, for example, they added about 5% to the cost of the project.

#### Leif Söderberg

SwedPower AB  
SE-162 16 Stockholm  
Sweden  
leif.soderberg@swedpower.vattenfall.se  
Fax: +46 (0) 8 739 62 31

#### Bernt Abrahamsson

ABB Power Technologies  
SE-771 80 Ludvika  
Sweden  
bernt.abrahamsson@se.abb.com  
Fax: +46 (0) 240 807 63

#### References

- [1] The making of the Baltic Ring. ABB Review 2/2001, 44–48.
- [2] **W. Deines:** The influence of electric currents on marine fauna. Cigré study committee no 10, 1959.
- [3] **Anders Liljestrand:** Kontrollprogram bottenfauna, bottenflora (Inspection program: bottom flora and fauna). Baltic Cable. Marin Miljöanalys AB, 1999.
- [4] **Håkan Westerberg:** Likströmskablar, ålar och biologiska kompasser (DC cables, eels and biological compasses). Fiskeriverkets Kustlaboratorium, 1999.
- [5] **E. Andrulewicz:** Field and laboratory work on the impact of the power transmission line between Poland and Sweden (SwePol link) on the marine environment and the exploitation of living resources of the sea. Sea Fisheries Institute Report, Gdynia, Feb 2001.

50 years

# HVDC

ABB – from pioneer to world leader

Gunnar Asplund, Lennart Carlsson, Ove Tollerz



**In 1954, at a time when much of Europe was busy expanding its electricity supply infrastructure to keep pace with surging demand, an event was quietly taking place on the shores of the Baltic Sea that would have a lasting effect on long-distance power transmission. Four years earlier, the Swedish State Power Board had placed an order for the world's first commercial high-voltage direct current (HVDC) transmission link, to be built between the Swedish mainland and the island of Gotland. Now, in 1954, it was being commissioned.**

**50 years on, ABB proudly looks back at its many contributions to HVDC technology. Since the laying of that early 90 kilometers long, 100-kV, 20-MW submarine cable, our company has gone on to become the undisputed world leader in HVDC transmission. Of the 70,000 MW of HVDC transmission capacity currently installed all over the world, more than half was supplied by ABB.**

**W**ith the arrival of the electric light bulb in the homes and factories of late 19<sup>th</sup> century Europe and the USA, demand for electricity grew rapidly and engineers and entrepreneurs alike were soon busily searching for efficient ways to generate and transmit it. The pioneers of this new technology had already made some progress – just being able to transmit power a few kilometers was regarded as something fantastic – when an answer to growing demand was found: hydroelectric power. Almost immediately, interest turned to finding ways of transmitting this ‘cheap’ electricity to consumers over longer distances.

#### **First direct, then alternating current**

The first power stations in Europe and the USA supplied low-voltage, direct current (DC) electricity, but the transmission systems they used were inefficient. This was because much of the generated power was lost in the cables. Alternating current (AC) offered much better efficiency, as it could easily be transformed to higher voltages, with far less loss of power. The stage was thus set for long-distance high-voltage AC (HVAC) transmission.

In 1893, HVAC got another boost with the introduction of three-phase transmission. Now it was possible to ensure a smooth, non-pulsating flow of power.

Although direct current had been beaten at the starting gate in the race to develop an efficient transmission system, engineers had never completely given up the idea of using DC. Attempts were still being made to build a high-voltage transmission system with series-connected DC generators and, at the receiving end, series-connected DC motors – all on the same shaft. This worked, but it was not commercially successful.

#### **AC dominates**

As the AC systems grew and power increasingly was being generated far from where most of its consumers lived and worked, long overhead lines were built,



Analog simulator used in the design of the early HVDC transmission systems

over which AC at ever-higher voltages flowed. To bridge expanses of water, submarine cable was developed.

Neither of these transmission media was without its problems, however. Specifically, they were caused by the reactive power that oscillates between the capacitances and inductances in the systems. As a result, power system planners began once again to look at the possibility of transmitting direct current.

### Back to DC

What had held up high-voltage direct current transmission in the past was, first and foremost, the lack of reliable and economic valves that could convert HVAC into HVDC, and vice versa.

The mercury-arc valve offered, for a long time, the most promising line of development. Ever since the end of the 1920s, when the Swedish ASEA – a founding company of ABB – began making static converters and mercury-arc valves for voltages up to about 1000 V, the possibility of developing valves for even higher voltages had been continually investigated.

This necessitated the study of new fields in which only a limited amount of exist-

ent technical experience could be applied. In fact, for some years it was debated whether it would be possible at all to find solutions to all the various problems. When HVDC transmission finally proved to be technically feasible there still remained uncertainty as to whether it could successfully compete with HVAC in the marketplace.

Whereas rotating electrical machines and transformers can be designed very precisely with the aid of mathematically formulated physical laws, mercury-arc valve design depends to a large degree on knowledge acquired empirically. As a result, attempts to increase the voltage in the mercury-vapor-filled tube by enlarging the gap between the anode and cathode invariably failed.

The problem was solved in 1929 by a proposal to insert grading electrodes between the anode and cathode. Subse-

quently patented, this innovative solution can in some ways be considered as the cornerstone of all later development work on the high-voltage mercury-arc valve. It was during this time that Dr. Uno Lamm, who led the work, earned his reputation as ‘the father of HVDC’.

### The Gotland link

The time was now ripe for service trials at higher powers. Together with the Swedish State Power Board, the company set up, in 1945, a test station at Trollhättan, where there was a major power plant that could provide energy. A 50-km power line was also made available.

Trials carried out over the following years led to the Swedish State Power Board placing, in 1950, an order for equipment for the world’s first HVDC transmission link. This was to be built between the island of Gotland in the Baltic Sea and the Swedish mainland.

Following on this order, the company intensified its development of the mercury-arc valve and high-voltage DC cable, while also initiating design work on other components for the converter stations. Among the equipment that benefited from the increased efforts were transformers, reactors, switchgear and the protection and control equipment.

Only some of the existing AC system technology could be applied to the new DC system. Completely new technology

was therefore necessary. Specialists in Ludvika, led by Dr. Erich Uhlmann and Dr. Harry

Even when HVDC transmission finally proved technically feasible, it was doubted for a long time whether it could compete with HVAC in the marketplace.

Forsell, set about solving the many very complex problems involved. Subsequently, a concept was developed for the Gotland system. This proved to be so successful that it has remained basically unchanged right down to the present time!

Since Gotland is an island and the power link was across water, it was



Early mercury-arc valve for HVDC transmission

During the 1960s several HVDC links were built: Konti-Skan between Sweden and Denmark, Sakuma in Japan (with 50/60 Hz frequency converters), the New Zealand link between the South and the North Islands, the Italy – Sardinia link and the Vancouver Island link in Canada.

The largest mercury-arc valve HVDC transmission link to be built by the company was the Pacific Intertie [1] in the USA. Originally commissioned for 1440 MW and later updated to 1600 MW at  $\pm 400$  kV, its northern terminal is sited in The Dalles, Oregon, and its southern terminal at Sylmar, in the northern tip of the Los Angeles basin. This project was undertaken together with General Electric, and started operating in 1970.

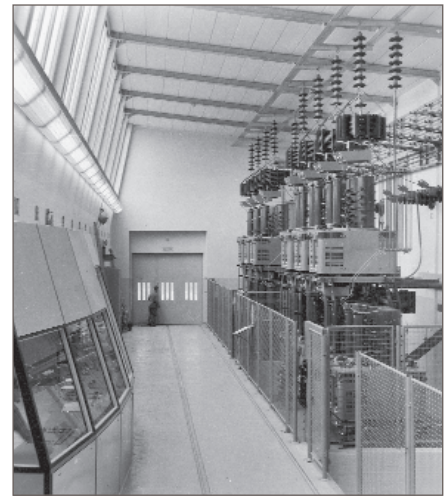

Mercury-arc valves in the first Gotland link, 1954

also necessary to manufacture a submarine cable that could carry DC. It was seen that the ‘classic’ cable with mass impregnated paper insulation that had been in use since 1895 for operation at 10 kV AC had potential for further development. Soon, this cable was being developed for 100 kV DC!

Finally, in 1954, after four years of innovative endeavor, the Gotland HVDC transmission link, with a rating of 20 MW, 200 A and 100 kV, went into operation. A new era of power transmission had begun.

The original Gotland link was to see 28 years of successful service before being finally decommissioned in 1986. Two new links for higher powers have meanwhile been built between the island and the Swedish mainland, one in 1983 and the other in 1987.

### Early HVDC projects

The early 1950s also saw the British and French power administrations planning a power transmission link across the English Channel. High-voltage DC transmission was chosen, and the company won its second HVDC order – this time a link for 160 MW.

The success of these early projects generated considerable worldwide interest.

In all, the company installed eight mercury-arc valve based HVDC systems for a total power rating of 3400 MW. Although many of these projects have since been replaced or upgraded with thyristor valves, some are still in operation today, after 30 to 35 years of service!

### The semiconductor ‘takeover’ begins

Mercury-arc valve based HVDC had come a long way in a short time, but it was a technology that still harbored some weaknesses. One was the difficul-

ty in predicting the behavior of the valves themselves. As they could not always absorb the reverse voltage, arc-backs occurred. Also, mercury-arc valves require regular maintenance, during which absolute cleanliness is critical. A valve that avoided these drawbacks was needed.

The invention of the thyristor in 1957 had presented industry with a host of new opportunities, and HVDC transmission was soon seen as a promising area



Gotland 1 extension, with the world's first HVDC thyristor valves

of application. As part of its activities in the semiconductor field, the company had continued to work at developing high-voltage thyristor valves as an alternative to the mercury-arc type. In the spring of 1967, one of the mercury-arc valves used in the Gotland HVDC link was replaced with a thyristor valve. It was the first time anywhere that this kind of valve had been taken into commercial operation for HVDC transmission. After a trial of just one year, the Swedish State Power Board ordered a complete thyristor valve group for each converter station, at the same time increasing the transmission capacity by 50 percent.

Around the same time, tests were carried out on the Gotland submarine cable, which had been operating without any problems at 100 kV, to see if its voltage could be increased to 150 kV – the level needed to transmit the higher power. The tests showed that it could, and this cable was subsequently operated at an electrical stress of 28 kV/mm, which is still the worldwide benchmark for large HVDC cable projects today.

The new valve groups were connected in series with the two existing mercury-arc valve groups, thereby increasing the transmission voltage from 100 to 150 kV. This higher-rated system was taken into service in the spring of 1970

– another world’s ‘first’ for the Gotland transmission link.

With the advent of thyristor valves it became possible to simplify the converter stations, and semiconductors have been used in all subsequent HVDC links. Other companies now began to enter the field.

Brown Boveri (BBC) – which later merged with ASEA to form

ABB – teamed up with Siemens and AEG in the mid-1970s to build the 1920-MW Cahora Bassa HVDC link between Mozambique and South Africa. The same group then went on to build the 2000-MW Nelson River 2 link in Canada. This was the first project to employ water-cooled HVDC valves.

The late 1970s also saw the completion of new projects. These were the Skagerak link between Norway and Denmark, Inga-Shaba in the Congo, and the CU Project in the USA.

The Pacific Intertie was also extended twice in the 1980s, each time with thyristor converters, to raise its capacity to 3100 MW at  $\pm 500$  kV. (ABB is currently

upgrading the Sylmar terminal by replacing the converters and control system.)

#### Itaipu – the new benchmark

The contract for the largest of all HVDC transmission schemes to date, the 6300-MW Itaipu HVDC link in Brazil, was awarded to the ASEA-PROMON

consortium in 1979. This project was completed and put into operation in several stages be-

tween 1984 and 1987. It plays a key role in the Brazilian power scheme, supplying a large portion of the electricity for the city of São Paulo.

The scale and technical complexity of the Itaipu project presented a considerable challenge, and it can be considered as the start of the modern HVDC era.

The experience gained in the course of its completion has been in no small way responsible for the many HVDC orders awarded to ABB in the years since.

After Itaipu, the most challenging HVDC project was undoubtedly the 2000-MW Québec – New England link. This was the first large multi-terminal HVDC transmission system to be built anywhere in the world.

#### HVDC cables have kept pace

As the converter station ratings increased, so too did the powers and voltage levels for which the HVDC cables had to be built.

The most powerful HVDC submarine cables to date are rated 600 MW at 450 kV. The longest of these are the 230-km cable for the Baltic Cable link between Sweden and Germany, and the 260-km cable for the SwePol link between Sweden and Poland.

#### HVDC today

The majority of HVDC converter stations built today are still based on the principles that made the original Gotland link such a success back in 1954. Station de-

The scale and complexity of the Itaipu project presented a considerable challenge, and it can be considered as the start of the modern HVDC era.



Foz do Iguaçu converter station with the Itaipu 12,600-MW power station in the background



sign underwent its first big change with the introduction of thyristor valves in the early 1970s. The first of these were air-cooled and designed for indoor use, but soon outdoor oil-cooled, oil-insulated valves were also being used. Today, all HVDC valves are water-cooled [2].

Good examples of modern bulk power HVDC transmission are the links ABB is installing for the Three Gorges hydro-electric power plant project in China. (See article starting on page 6.)

In 1995 ABB presented a new generation of HVDC converter stations: 'HVDC 2000' [3]. HVDC 2000 was developed to meet stricter electrical disturbance requirements, to provide better dynamic stability where there was insufficient short-circuit capacity, to overcome space limitations, and to shorten delivery times.

A key feature of HVDC 2000 was the introduction of capacitor commutated converters (CCC). This was, in fact, the first fundamental change to have been made to the basic HVDC system technology since 1954!

HVDC 2000 also includes other ABB innovations, such as continuously tuned AC filters (ConTune), active DC filters, outdoor air-insulated HVDC valves, and the fully digital MACH2™ control system.



Submarine cable for the 600-MW Baltic Cable HVDC link between Germany and Sweden



Baltic Cable HVDC converter station

The first project to employ HVDC 2000 with CCC and outdoor valves was the Garabi 2200-MW HVDC back-to-back station in the Brazil – Argentina HVDC Interconnection.

#### HVDC Light™

HVDC technology has become a mature technology over the past 50 years and reliably transmits power over long distances with very low losses. This begs the question: where is development work likely to go in the future?

It was conceived that HVDC development could, once again, take its cue from industrial drives. Here, thyristors were replaced a long time ago by voltage source converters (VSC), with semiconductors that can be switched off as well as on. These have brought many advantages to the control of industrial drive systems and it was realized that they could also apply to transmission systems. Adapting the technology of voltage source converters to HVDC, however, is no easy matter. The entire technology has to change, not just the valves.

As development of its VSC converter got under way, ABB realized that the insulated gate bipolar transistor, or IGBT, held more promise than all the other available semiconductor components. Above all else, the IGBT needs only

very little power for its control, making series connection possible. However, for HVDC a large number of IGBTs would have to be connected in series, something industrial drives do not need.

In 1994, ABB concentrated its development work on VSC converters in a project that aimed at putting two converters based on IGBTs into operation for small-scale HVDC.

An existing 10-km-long AC line in central Sweden was made available for the project.

At the end of 1996, after comprehensive synthetic tests, the equipment was installed in the field for testing under service conditions. In 1997 the world's first VSC HVDC transmission system, HVDC Light™ [4], began transmitting power between Hellsjön and Grängesberg in Sweden.

In the meantime, seven such systems have been ordered, and six of them are now in commercial operation in Sweden, Denmark, the USA and Australia. HVDC Light is now available for ratings up to 350 MW, ±150 kV.

ABB is to date the only company that has managed to develop and build VSC HVDC transmission systems [5].

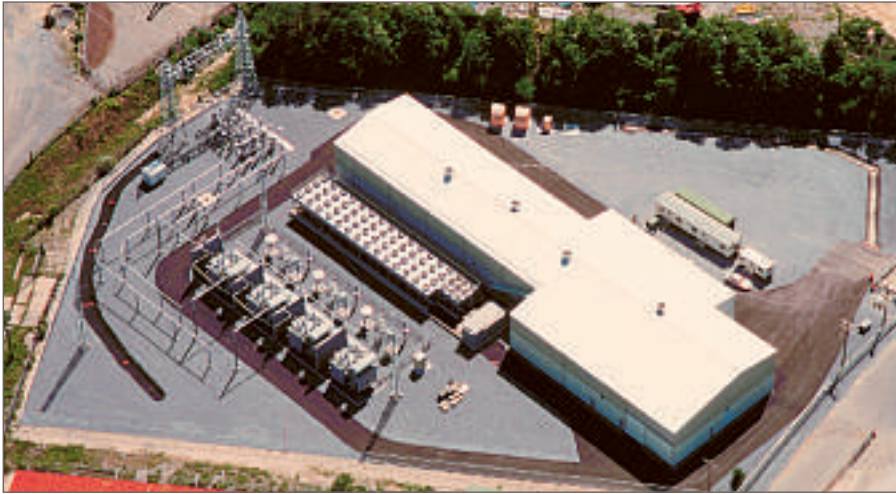

Shoreham station, 330-MW HVDC Light™ Cross Sound Cable link, USA



HVDC Light land cable

One advantage of HVDC Light is that it allows an improvement in the stability and reactive power control at each end of the network. Also, it can operate at very low short-circuit power levels and even has black-start capability.

The HVDC Light cable is made of polymeric material and is therefore very strong and robust. This makes it possible

to use HVDC cables where adverse laying conditions might otherwise cause damage. Extruded cable has also made very long HVDC cable transmission on land now economically viable. An example is the 180-km-long HVDC Light™ interconnection 'Murraylink' in Australia.

#### And the next 50 years?

HVDC transmission has come a long

way since that first Gotland link. But what does the future hold for it?

Bulk transmission is likely to rely on thyristor-based technology for many years since it is reliable and low in cost, plus losses are low. Increasing the voltage is one way to go

here as it would allow much higher powers and very long distances for the links.

HVDC Light has the potential to be developed further. One direction might be toward higher voltages and powers, but low power and relatively high voltages are also conceivable for systems for smaller loads and generators.

The introduction of capacitor commutated converters was the first fundamental change made to the basic HVDC technology since 1954!

The development of HVDC Light cable has made it possible to link up networks across very deep waters that have previously made such schemes unthinkable. The most interesting prospects for HVDC Light, however, lie in its potential for building multi-terminal systems. In the long term it might offer a genuine alternative to AC transmission, which today completely dominates this sector.

**Gunnar Asplund**

**Lennart Carlsson**

ABB Power Technologies

Ludvika/Sweden

gunnar.asplund@se.abb.com

lennart.k.carlsson@se.abb.com

**Ove Tollerz**

ABB Power Technologies

Karlskrona/Sweden

ove.tollerz@se.abb.com

#### References

- [1] **L. Engström:** More power with HVDC to Los Angeles. ABB Review 1/88, 3–10.
- [2] **B. Sheng, H. O. Bjarna:** Proof of performance – a synthetic test circuit for verifying HVDC thyristor valve design. ABB Review 3/2003, 25–29.
- [3] **B. Aernlov:** HVDC 2000 – a new generation of high-voltage DC converter stations. ABB Review 3/1996, 10–17.
- [4] **G. Asplund, et al:** HVDC Light – DC transmission based on voltage sourced converters. ABB Review 1/1998, 4–9.
- [5] **T. Nestii, et al:** Powering Troll with new technology. ABB Review 2/2003, 15–19.

Further information on HVDC can be found at [www.abb.com/hvdc](http://www.abb.com/hvdc)

**ABB Review**  
**Special Report**  
**Power Technologies**

**Editorial board**

Markus Bayegan  
Group R&D and Technology

Georg Schett  
ABB Power Technologies

Klaus Treichel  
ABB Power Technologies

Nils Leffler  
Chief Editor, ABB Review

**Publisher and copyright © 2003**

ABB Ltd  
Zurich/Switzerland

**Publisher's office**

ABB Schweiz AG  
Corporate Research  
ABB Review / RD.REV  
CH-5405 Baden-Dättwil  
abbreview.abbzh@ch.abb.com

**Printers**

Vorarlberger Verlagsanstalt AG  
AT-6850 Dornbirn/Austria

**Design**

DAVILLA Werbeagentur GmbH  
AT-6900 Bregenz/Austria

Partial reprints or reproductions are permitted  
subject to full acknowledgement.

Complete reprints require the publisher's  
written consent.

ISSN: 1013-3119

[www.abb.com/abbreview](http://www.abb.com/abbreview)

# Don't let your city lose its shine.



©ABB 2003

## Proven power technologies integrated in record time

ABB's cutting edge technologies for grid reliability include HVDC and FACTS: High Voltage Direct Current (HVDC) technology by ABB has built-in overload control and can be loaded fully without increasing the risk of cascaded line tripping. Our Flexible AC Transmission Systems (FACTS) allow more power to flow on existing lines with minimum impact on the environment, substantially shorter project implementation times, and this at lower costs.

**Contact the worldwide market leader in power technologies:**

**[www.abb.com/poweroutage](http://www.abb.com/poweroutage)**

The ABB logo, consisting of the letters 'ABB' in a bold, red, sans-serif font.