



Power on tap

A pumped storage solution
to meet energy and tariff demands

STEVE AUBERT – The latest developments in power electronics and machine technologies open a new trend for large hydro pumped storage applications. Pumped storage power plants (PSPP) with variable speed units offer several advantages compared to the conventional fixed speed solutions. Variable speed can be achieved with doubly fed induction machines controlled by AC Excitation systems. These systems feed the rotor circuits of the machines with low frequency three phase currents and control the speed or active power and reactive power of the machines. The pumped storage power plant

Avče, in Slovenia, is the first variable speed installation in Europe with a state of the art three-level Integrated Gate-Commutated Thyristor (IGCT) Voltage Source Converter system. ABB Switzerland Ltd's MV Power Converter Systems department provided electrical and mechanical engineering, installation and commissioning of the PCS 8000 AC Excitation system, including an excitation transformer. After the successful completion of commissioning, the unit has been handed over to the customer SENG d.o.o. and has been in commercial operation since April 2010.



The Slovenian power generation mix is provided by approximately two thirds nuclear and coal fired power plants and one third hydro generation, mainly run-off river power plants. These generation capacities supply mainly base load and intermediate electrical energy. Under these circumstances the control of electricity production, according to demand, is difficult to achieve. The country faces a lack of peak energy capacities for covering high demand and over-capacity during low demand periods, especially overnight or during weekends. With a large electricity price gap between peak and low consumption hours, this situation leads to a negative influence on the overall energy price. At the same time, with cross-border connections to Italy, Croatia and Austria, Slovenia is located at the crossroad of international energy flows in the new European transmission operation network. The Slovenian network must bear its share of responsibility for international energy transfer. To satisfy the needs and expectations of consum-

ers, adequate interconnections between regions and sufficient generation capacities must be ensured. For continuity of electricity supply and to prevent blackouts, transmission network rules also have to be respected.

Based on these considerations, Soške Elektrarne Nova Gorica d.o.o. (SENG), an affiliated company of the Slovenian Energy Group HSE (Holdinga Slovenske Elektrarne) d.o.o., decided to invest in the first PSPP in the country. Hydro pump storage facilities offer the possibility of absorbing large amounts of energy during low price periods, especially at nights and during weekends, by transforming electrical energy into the form of potential energy using a pump. In the high consumption periods, when the electricity prices are

high, the plant uses the accumulated water to generate electricity. With this storage generation process, nuclear and coal fired power plants can be run at the optimal operating point continuously, even during low demand periods. Costly and inefficient variations in generation set points for steam power plants can so be reduced.

The main advantage of the variable-speed solution is the possibility for active power regulation in pumping mode.

The location of Avče, near the city of Nova Gorica, at the western border of the country, has the advantage of providing existing low reservoir facilities on the

Title Picture

View on the upper reservoir of the Avče pumped storage power plant, and the landscape.

Hydro pump storage facilities offer the possibility of absorbing large amounts of energy during low price periods. In high consumption periods, the plant uses the accumulated water to generate electricity.

Soča river, but also a large geological variation in elevation → 1. Additionally the switchgear station connects the powerhouse electrically to the existing 110 kV Northern Primorska loop, which is also connected to a cross-border transmission line to Italy, some kilometers away. The pumped storage power plant will also support the development of conventional hydro generation facilities in the region. To realize the pumped storage power plant, the upper-water reservoir, headrace tunnel, surge tank, pressure penstock and the powerhouse were built. The powerhouse, sitting on the left bank of the Soča River, is made of an 80m deep powerhouse shaft and an overhead section. Inside the shaft, the reversible pump-turbine and motor-generator are installed with their auxiliaries. The powerhouse building is equipped with the excitation system device as well as circuit breakers, transformers, diesel generator, batteries, mobile cranes, etc.

Optimized pumped storage operation

With the focus on a most efficient pumped storage operation, SENG decided to install a 195 MVA reversible variable-speed unit. This variable-speed pumped storage setup provides several advantages when compared to the traditional solutions with fixed speed. In classic fixed speed solutions with synchronous machines, only the reactive power can be adjusted by the excitation unit. While generating, active power can be adjusted only mechanically, using the guide vane. In pump mode no adjustment of the absorbed active power is possible at all. With a variable-speed

solution, the active and reactive powers of the machine are adjusted through the AC Excitation system during both pump and generation operations. This leads to several technical advantages resulting ultimately in economic advantages.

The reversible Francis pump-turbines are usually designed for nominal head and rated machine power. With continuous changes of the effective head, practical operation points with fixed speed are usually operating in the region of, but not exactly on, the design point. Therefore pump-turbines with fixed-speed units usually run below their optimum efficien-

The control algorithms used for rotating frequency converters have been improved continuously for more than thirty years.

cy. In generator mode, the pump-turbine efficiency can be improved for partial load operation by adjusting the speed according to the required power and actual head. Whereas in pump mode, the pump-turbine can be operated either at optimal efficiency according to actual head or according to available power from grid. This leads to a broader opera-

1 The Avče power house located on the Soca river side, looking over the lower reservoir



tion range during pump and generation periods, with an improvement of the pump-turbine cycle efficiency of up to more than 77 percent at the Avče pumped storage power plant.

The main advantage of the variable-speed solution is the possibility for active power regulation in pumping mode, in the case of Avče within the range of 65 to 100 percent of rated power. The possibility of controlling the absorbed active power in pump mode allows flexible energy storage according to the available power on the electrical network, even though the available power fluctuates depending on the gap between production and demand. This flexibility is a good fit for optimized storage behavior, increasing the amount of stored energy in a similar time, but also reducing drastically the number of start-stop sequences compared to fixed-speed units. In addition, active power regulation allows for contributions to the primary grid frequency control (ancillary service) even in pumping mode. With conventional fixed-speed units this service has to be performed separately by running a generator unit during low consumption and electricity prices. Clearly, generating when energy prices are low is not financially sensible, so variable-speed pumped storage units allow the maximization of economic advantages: generating higher revenues through optimized pump-generation operation and services to the network.

The power regulation of the variable-speed machines will also generally play an important role in the integration of

2 Single-line diagram of AC Excitation system

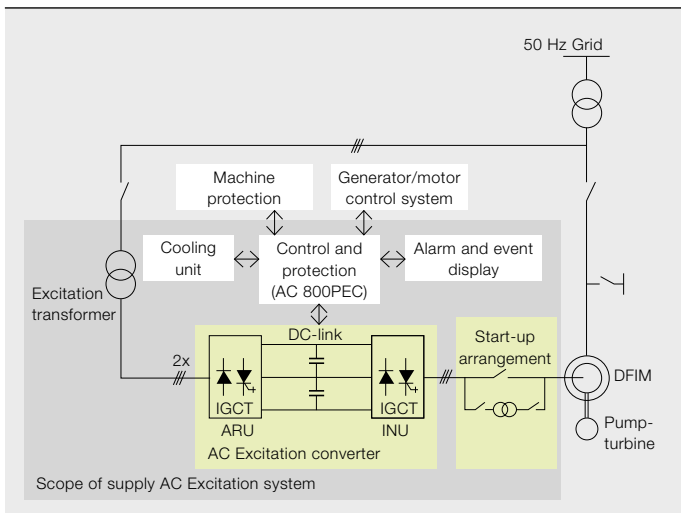

3 ABB PCS 8000 AC Excitation system in its containerized solution installed in the power house



even larger amounts of wind and other renewable energy sources. Even for those renewable production facilities whose production may be predictable, their production can not be allocated according to the demand. Hydro pumped storage provides the largest and most cost efficient solution for the integration of intermittent generation sources into the actual electrical network. Moreover, additional greenhouse gas emissions from peak energy generation from gas turbine power plants can be avoided.

ABB AC Excitation

The variable-speed pumped storage unit incorporates a doubly fed induction machine (DFIM). Doubly fed induction machines have a three-phase slip ring connection to the wound rotor. By applying low frequency AC currents from the so called AC Excitation system to the rotor, variable-speed operation is achieved. The frequency of the rotor currents is related to the difference between the actual rotational speed and the synchronous speed, dependant on grid frequency. The PCS 8000 AC Excitation actually controls the rotor slip compared to the synchronous speed. At the same time, vector control of the excitation currents allows not only for the speed/active power control but also control of the voltage/reactive power for the machine. This latter control is done similarly by a conventional DC Excitation like ABB Unitrol® for a synchronous machine. The startup/breaking sequence of the machine is achieved with the same PCS 8000 AC Excitation system. No additional starter is required.

Based on the fact that variable-speed units control active and reactive power separately, additional contributions to grid stability can be achieved. Variable-speed power plants do not need any power system stabilizer (PSS) functionality. Active power control of the machine improves stability and enables fast reactions to perturbations from the grid. The variable-speed units act as damping elements for the whole network, which means: absorbing the power oscillations created by synchronous generators. Electronic speed control reduces the response time drastically in comparison to mechanical control by the hydraulic guide vanes equipment. As the speed of the unit does not need to be synchronous to the grid, one could see a variable-speed power plant also as fly-wheel storage for short term phenomena. These superior control capabilities can be utilized to stabilize long transmission lines.

ABB's PCS 8000 AC Excitation

For the Avče project, ABB's scope of supply was the AC Excitation converter, together with its control unit and converter protection, excitation transformer and start-up arrangement → 2. ABB was responsible for engineering, project management, manufacturing and factory acceptance test, as well as installation and commissioning on site. The whole project was realized and conducted from

the production site of ABB's Automation Products division based in Turgi, Switzerland. The production site in Turgi is responsible for PCS 8000 AC Excitation systems worldwide.

The AC Excitation was delivered as a containerized solution, including the converter, control and protection cubicle and the water cooling unit → 3,4,5. The whole arrangement was assembled and fully tested at ABB premises in order to provide a reduced installation and commissioning time on site. The control software, including protection functions for the converter and the excitation transformer, were factory checked before commissioning on a real-time hardware-in-the-loop simulator. Once more, this drastically improved the commissioning time on site, avoiding waiting time during test periods.

The ABB AC Excitation system is based on state of the art, three-level, voltage source converter (VSC) topology. Power electronic frequency converters from ABB have a long-standing tradition. The

Greenhouse gas emissions from peak energy generation from gas turbine power plants can be reduced.

first generation was delivered in 1970s. The VSC technology is used by ABB for several applications such as railway grid interties, static reactive power compen-

4 View inside the power house with the ABB PCS 8000 AC Excitation system



6 PCS 8000 AC Excitation IGCT converter arrangement inside the container



5 AC Excitation Transformer with the 3 bus ducts (yellow on the left) for primary windings supply and the 6 bus connection to the 12 pulse ARU



sators (STATCOM), static frequency converters for energy supply applications and also, since the early 1990s, AC Excitation for DFIM for rotating frequency converters. With more than twenty installed AC Excitation converters, ABB offers a wide range of experience with DFIM applications. The control algorithms used for rotating frequency converters have been improved continuously for more than thirty years. This large range of proven field experience has helped to guide the specific requirements for pumped storage applications and ensures a reliable and safe implementation and operation of the machine. The ABB voltage source converter topology is based on IGCT semiconductor elements assembled in so-called three-level power electronic building blocks (PEBB) → 6. From these PEBBs, the converters are assembled. For the Avče project requirements, the PCS 8000 AC Excitation system setup contains two three-phase systems on the active rectifier unit (ARU) and one three-phase system on the inverter unit (INU) connected by a single DC link → 7. The so-called “12-pulse ARU topology” has typical advantages in regards to harmonics performance. The INU has four phase legs in parallel, in order to supply the required rotor currents for rated operation, including reserve for transient situations. The coupling of the two voltage inverters via a DC link provides a very high operational flexibility. Frequency, voltage and power factor can be controlled independently on both sides, and no reactive

power supply to the excitation system is necessary. The DC link is equipped with a voltage limiter unit (VLU). The task of the VLU is to ensure that the DC link voltage is kept within limits.

IGCT semiconductor elements are a leading technology in high power converters because they provide the advantages of gate turn-off (GTO) combined with the advantages of insulated gate bipolar transistor (IGBT) semiconductors. The conducting losses are low, as in GTOs, and the state transitions are comparably fast, as with IGBTs. Due to the monolithic structure, IGCTs show the same overload behavior as thyristors and GTOs. In case of a semiconductor failure, the current will establish a conducting channel in the silicon wafer. Under fault conditions this behavior ensures the mechanical integrity of the semiconductor housing, as well as the conducting path for the rotor circuit in variable speed applications, avoiding dangerous rotor overvoltage. Not all other semiconductor types available on the market tend to show the same fail-safe behavior.

The control system of the AC Excitation is based on ABB's AC 800PEC platform, specially designed for high-speed control of power semiconductors. The control cabinet contains the AC 800PEC controller hardware as well as all the necessary I/O devices from/to generator/motor control system, AC Excitation converter, excitation transformer, cooling system and voltage/current transform-

7 Detailed diagram of the PCS 8000 AC Excitation system with its single DC Link unit for improved system stability and optimized footprint

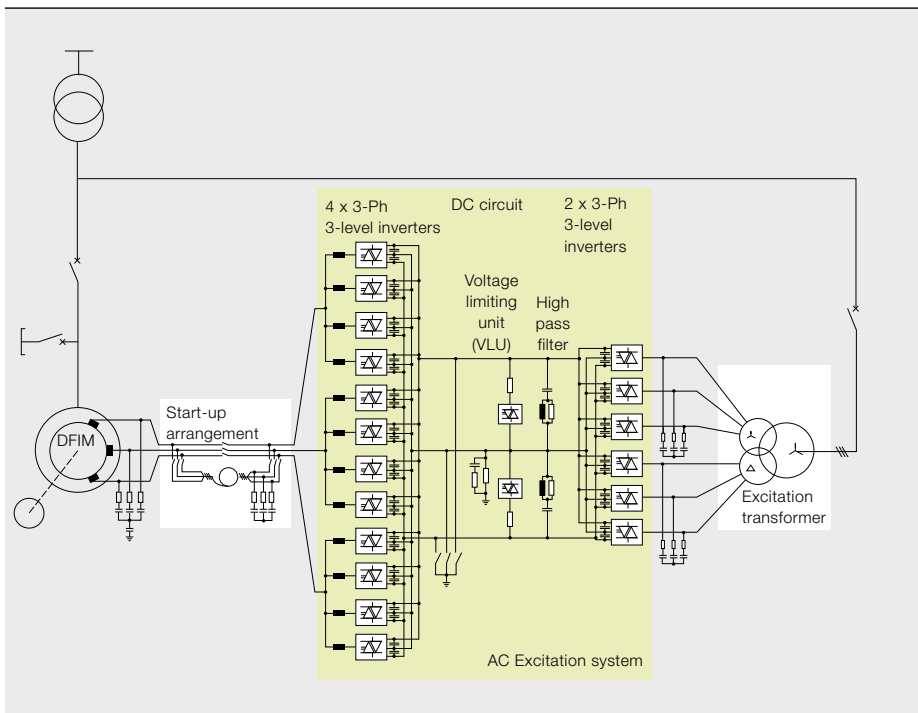

8 The dam and the beautiful countryside around the Avče power plant



allows the machine to start-up and to synchronize in less than four and a half minutes for pump operation. In generator mode, the process is similar to synchronous machines. Nevertheless, in both cases, as the motor/generator is an asynchronous machine, the synchronization of the unit does not have to take place at synchronous speed. Only the stator voltage and the phase's angle difference on both sides of the generator breaker must be considered.

All round beauty

The variable-speed pumped storage power plant at Avče, with ABB's PCS 8000 AC Excitation voltage source converter equipment, brings very important benefits to the site operator SENG d.o.o. and the grid operator. It matches perfectly the electrical network requirements, the geographical situation and the economic aspects → 8. It produces peak energy shifted from low demand periods, offers flexibility of operation in the open electric energy market and provides primary reserves for network control service, in the mean time stabilizing energy transmission lines around the site. With its fast startup time in turbine and pump mode, the DFIM at Avče is, even when offline, set as the stand-by unit by the network operator, ready to start instantaneously in case of any sudden unbalanced situation in the network. Unquantifiable benefits are also provided by the tourist development on the upper reservoir area which increases the attractiveness of the beautiful countryside in this region of Slovenia.

Steve Aubert
 ABB Automation Products
 Turgi, Switzerland
 steve.aubert@ch.abb.com

ers. The AC 800PEC controller belongs to ABB's widely established 800xA family, and combines a very powerful CPU

As the speed of the unit does not need to be synchronous to the grid, the variable-speed plant can act as short-term fly-wheel storage.

and large field-programmable gate array, which suits the AC 800PEC to control demanding power electronics systems.

The ABB control algorithms comprise loops for speed/active power and voltage/reactive power controls, DC link control, startup/braking and synchronization sequences, as well as control of the system auxiliaries, such as water cooling units, cooling fans, etc. Furthermore, the AC 800PEC (control PEC) manages the communications with the superimposed unit control system and the excitation/governor control, providing the operation set points. The moni-

toring and protection of the converter and excitation transformer are programmed in a separate AC 800PEC (protection PEC) controller. Nevertheless, in order to ensure the safety of the equipment, the main protection functions are programmed as a backup in the control PEC as well, providing redundancy for the main protection scheme.

By means of a service PC, all necessary software maintenance and diagnostics are possible by local by ABB personnel or, with an appropriate internet connection, also from remote locations. This remote access function allowed ABB to actively support the double feed induction machine tests, performed on site during commissioning of the motor-generator, from the office. ABB could set power and speed set points according to on-site test requirements which were simply given by phone. This reduced the number of ABB specialists on site therefore reducing the cost of commissioning. The startup/braking sequences of the machine are achieved with the same PCS 8000 AC Excitation system and no additional starter equipment is required. The startup function in motor mode is fully integrated in the PCS 8000 AC Excitation software, as well as the synchronization and the breaking sequences. A start-up unit, increasing the rotor voltage during start-up phase is installed. This