

ESTABLISH WIRELESS CONNECTIVITY BETWEEN MODBUS RTU DEVICES AND THE SMART COMMUNICATION CARD (SCC)

Step-by-step guide to connecting Modbus RTU devices to the Smart Communication Card (SCC) using CM-TCN.012 as an example

ENGINEERED
TO OUTFIT

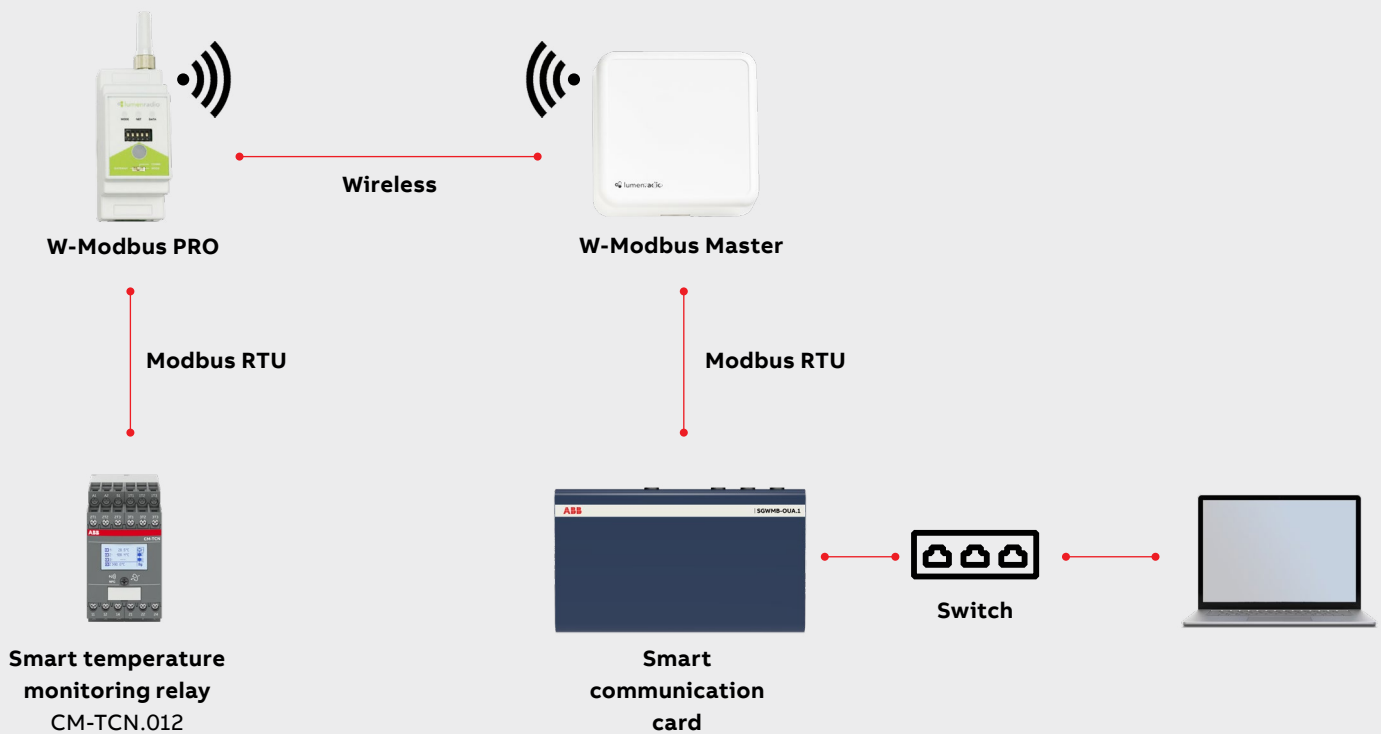

Table of contents

4	Purpose and basic description
5	Important disclaimers & recommendations
6	Basic architecture
8	Basic configuration of SCC
12	Setting up W-Modbus devices

1. Purpose and basic description

This document defines the requirements for an application note that delivers step-by-step instructions for wirelessly connecting the CM-TCN.012 (as the example) and other Modbus RTU slave devices to the Smart Communication Card (SCC).

1.1. Smart Communication Card?

Digital transformation begins at the edge. The Smart Communication Card allows your equipment to securely connect to cloud platforms using standard protocols such as OPC UA and MQTT, as well as to field devices over OPC UA, Modbus RTU, and Modbus TCP. Equipped with built-in control capabilities, it facilitates local control logic, data logging, and real-time processing, which helps reduce latency and enhance system resilience. Whether you're monitoring an individual machine or scaling across decentralized systems, the Smart Communication Card provides a flexible and easily deployable IoT solution that brings both cloud connectivity and control closer to your operations.

1.2. W-Modbus Device

W-Modbus replaces the Modbus RTU cable with a reliable wireless mesh - it eliminates time-consuming installation planning, cabling, daisy-chaining and troubleshooting. Avoiding cabling has never been easier. A W-Modbus network consists of a single W-Modbus gateway connected to the Modbus client using a Modbus RTU cable and up to 100 W-Modbus nodes.

Note: The W-Modbus Master device is not an ABB product.

2. Important disclaimers & recommendations

2.1. Cyber security legal disclaimer

The Smart Communication Card is designed to be connected to the ABB and 3rd party products and communicate information data from Novolink modules via network interface. It is the user's sole responsibility to provide and continuously ensure a secure connection between the product and the user's network or any other. The user shall establish and maintain any appropriate measures (such as but not limited to the installation of firewalls, application of authentication measures, encryption of data, installation of anti-virus programs, etc.) to protect the product, the network, its system, and the interface against any kind of security breaches, unauthorized access, interference, intrusion, leakage and/or theft of data or information. ABB and its affiliates are not liable for damages and/or losses related to such security breaches, any unauthorized access, interference, intrusion, leakage and/or theft of data or information. The data, examples and diagrams in this manual are included solely for the concept or product description and are not to be deemed as a statement of guaranteed properties. All people responsible for applying the equipment addressed in this manual must satisfy themselves that each intended application is suitable and acceptable, including that any applicable safety or other operational requirements are complied with. Any risks in applications where a system failure and/or product failure would create a risk for harm to property or persons (including but not limited to personal injuries or death) shall be the sole responsibility of the person or entity applying the equipment, and those so responsible are hereby requested to ensure that all measures are taken to exclude or mitigate such risks. This document has been carefully checked by ABB, but deviations cannot be completely ruled out. In case any errors are detected, the reader is kindly requested to notify the manufacturer. Other than under explicit contractual commitments, in no event shall ABB be responsible or liable for any loss or damage resulting from the use of this manual or the application of the equipment.

2.2. UaExpert

UaExpert is software, provided by Unified Automation. It is recommended to use this software for monitoring the data as described in the "UaExpert" chapter

Important: This software does not belong to ABB, and we don't take any responsibility for its functionality.

2.3. JSON files

JSON files are provided as examples on how data can be retrieved from the devices. Please see chapter JSON files for details. User must adapt the files according to the application requirement.

2.4. Making your Networks more secure:

The following points are strongly recommended to make networks more secure:

- **Isolate your network** – separate the OT network (operation technology) from the IT network (information technology). This helps prevent any attack reaching the IT network from spreading to the OT network.
- **Use firewalls** – Implement firewalls to prevent unauthorized access to the OT network.
- **Use access control** – Implement access controls to restrict the human and device access to the OT network.
- **Keep software up to date** – Make sure all software/firmware of the devices are up to date to have the latest security updates installed.
- **Reduce attack surface on devices** – Disable device functions, services and ports not needed.
- **Replace default passwords** – Replace all default passwords of the devices to prevent attacker from getting access using default credentials.
- **Monitor network activity** – Monitor the OT network for any malicious activities that could be a sign of an attack. An example of network monitoring tool is intrusion detection systems (IDS).
- **Train employees** – Train operators and service people on IT and OT security best practices.

2.5. In this applicaiton note LumenRadio devices are used. More information are available at: <https://lumenradio.com/>

Important: This hardware and realted software does not belong to ABB and ABB does not take any responsibility for its functionality.

3. Basic architecture

This section describes the basic steps required to set up the SCC. In addition, it will be described how to set up devices to Smart Communication Card over OPC UA, Modbus RTU wirelessly using third party devices.

Web-based portal will be used to set up SCC.

The setup can be done as shown in the picture below:

The figure shows that:

CM-TCN.012 (5) and Modbus device Pro (6) are connected through wire. Smart Communication Card (4) is connected to other Modbus (3) over Modbus RTU through wire, W-Modbus is third Party Modbus Device.

Note: The third-party wireless Modbus PRO device is used only to replace wires. It does not need any new configuration. Its plug and play devices.

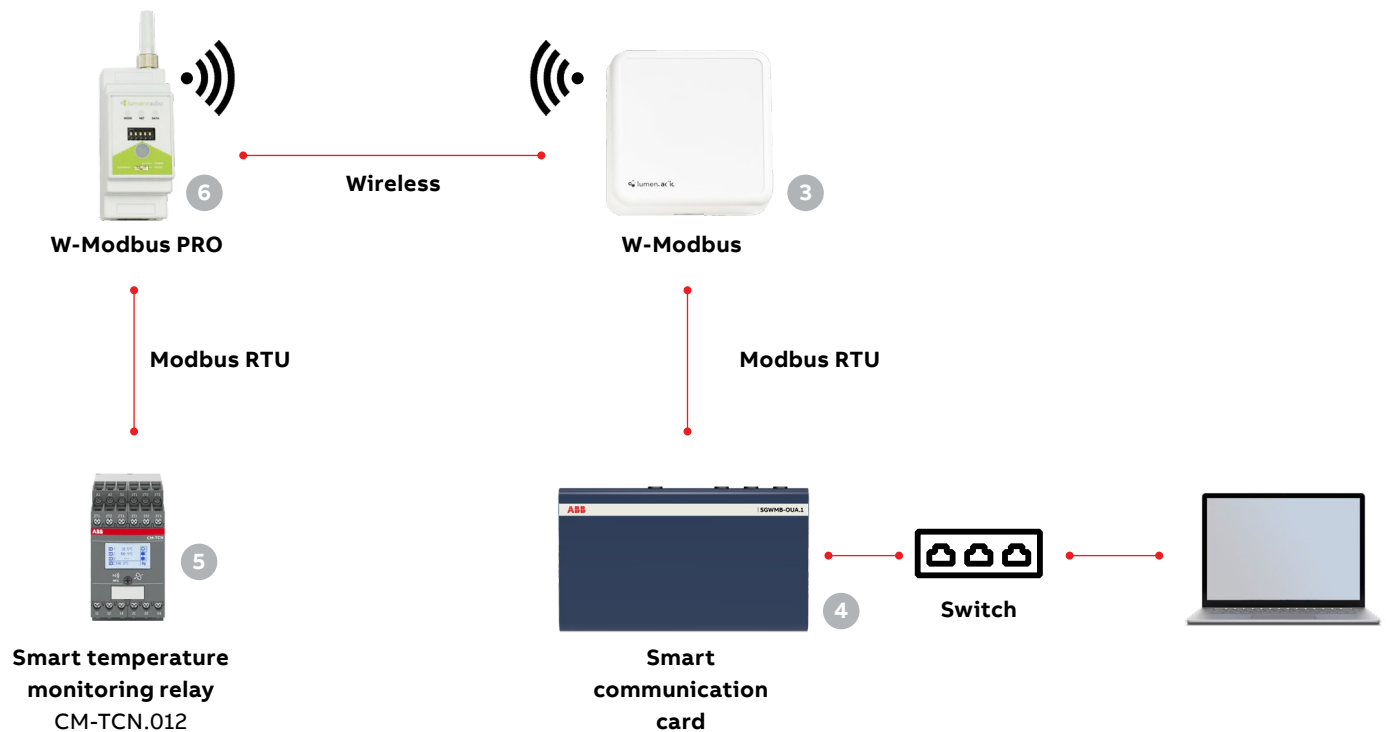

3.1. What do you get?

ABB will deliver the following devices: CM-TCN.012

Note:

- These devices need to be placed in a /demo set up demo box.
- UaExpert is required to verify the data of SCC. ABB will test and share the application to show data coming from gateway in UaExpert.
- ABB will share the user manuals.
- UaExpert is not an ABB software.
- ABB will not deliver W-Modbus devices. It is a third-party device.
- Json files for CM-TCN.012, PSTX and UMC100.3

Important: JSON files are provided as examples on how data can be retrieved from the devices. Please see chapter JSON files for details. Users must adapt the files according to the application requirement.

3.2. Hardware and Software Required

3.2.1. Hardware

To mount the unit, place the upper edge of the DIN rail adapter on the upper edge of the DIN rail, holding the unit tilted slightly upward, as shown in the illustration. Then tilt the unit down until the latch snaps onto the DIN rail.

1. The SCC (Smart Communication card)
2. W-Modbus DIN rail (Slave/SKU 840-2120)
3. W-Modbus wall mount (Master/SKU 840-2114)
4. Two power supplies, one for the W-Modbus DIN rail device (act as master in our case) and the other is to power up node (Wireless Modbus Pro device which acts as slave).

3.2.2. Software:

Uaexpert is required to verify the data from SCC. For SCC configuration a web-based portal is used. W-Modbus

3.2.3. Wiring and Power Up

Wiring must be done using the schematic shown below.

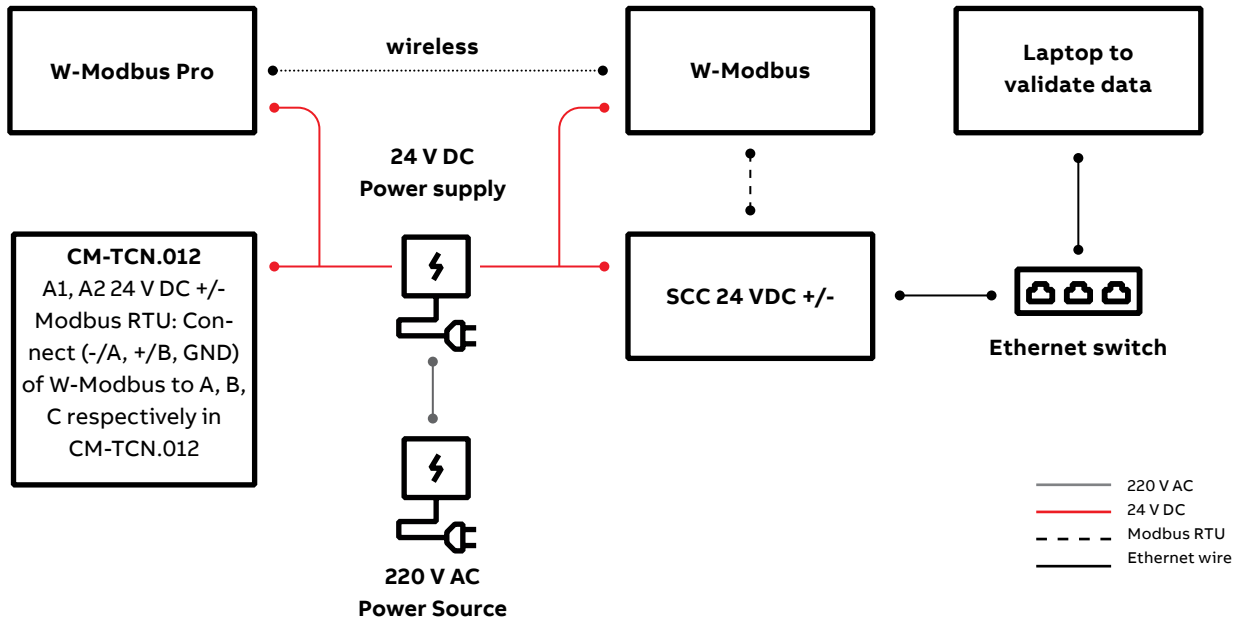

24 VDC	24VDC is connected to the SCC. 24 VDC is connected to CM-TCN.012 or any other device that needs to connect to the gateway
220 VAC	220 VAC is required for power supply.
Modbus RTU	Connect A+ of the W-Modbus (Master) device to A+ and B to B of SCC. And connect A+ of W-Modbus Pro (Slave) device to A+ and B to B of SCC. In some devices, it is written as D+ and D- equivalent to A+.

4. Basic configuration of SCC

4.1. Configuring IP Address of SCC

Ensure that your system or laptop is on the same subnet as the SCC. By default, the SCC IP address is 192.168.2.1.

For example: You can provide any IP to your system from 192.168.2.x to 192.168.2.x, where x can be from 2 to 254..

Please make sure not to configure any IP address that is already in use. Here in this case, it is the IP of the SCC, or it could be the IP of any slave device. For any confusion refer to the below image.

DNS server assignment:	Automatic (DHCP)	Edit
Link speed (Receive/Transmit):	1000/1000 (Mbps)	Copy
Link-local IPv6 address:	fe80::57da:532e:bce0:8a16%11	
IPv4 address:	10.49.113.31	
IPv4 DNS servers:	10.49.6.11 (Unencrypted) 10.16.7.12 (Unencrypted)	
Primary DNS suffix:	de.abb.com	
Manufacturer:	Realtek	
Description:	Lenovo USB Ethernet	
Driver version:	1153.13.420.2023	
Physical address (MAC):	F4-AB-0D-A0-D6-6C	

- Connect the SCC and your laptop via Ethernet cable.
- To verify, if the connection between SCC and your system is established, open Command Prompt and run this command `ping 192.168.2.1 -t` or you can directly run `ping 192.168.2.1`, where `-t` switch is used in **Windows** to make the ping command **continue sending echo requests indefinitely** until you manually stop it (usually by pressing Ctrl + C).
- Command: `ping 192.168.2.1 -t` for checking connectivity.

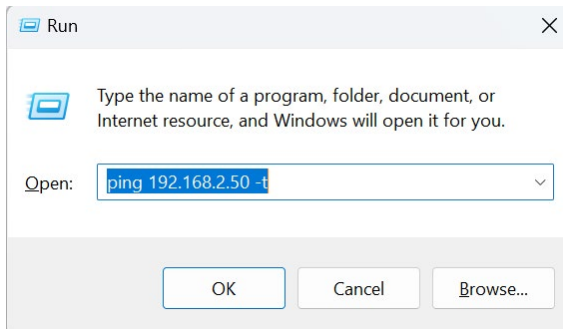

The result:

```

C:\WINDOWS\system32\ping x
Pinging 192.168.2.1 with 32 bytes of data:
Reply from 192.168.2.1: bytes=32 time=2ms TTL=64
Reply from 192.168.2.1: bytes=32 time=1ms TTL=64
Reply from 192.168.2.1: bytes=32 time=1ms TTL=64
Reply from 192.168.2.1: bytes=32 time=1ms TTL=64
Reply from 192.168.2.1: bytes=32 time=1ms TTL=64
Reply from 192.168.2.1: bytes=32 time=1ms TTL=64
Reply from 192.168.2.1: bytes=32 time=5ms TTL=64
Reply from 192.168.2.1: bytes=32 time=2ms TTL=64

```

Note: In case of timeout please verify below details:

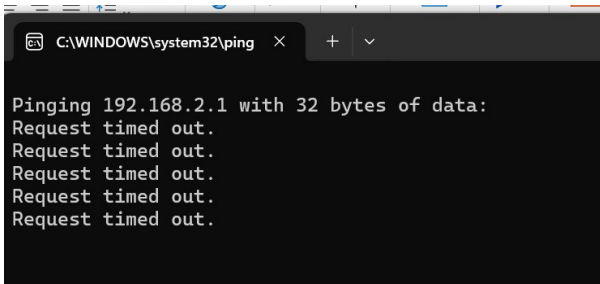

1. See if your ethernet cable is properly connected or not.
2. Check your system's IP if it is properly configured.

Once the SCC is properly connected to your PC, open any web browser and enter the default IP address 192.168.2.1, as illustrated in the figure below. This will launch the SCC's web-based portal, prompting you to log in with the default username and password.

Username:admin
 Password:admin

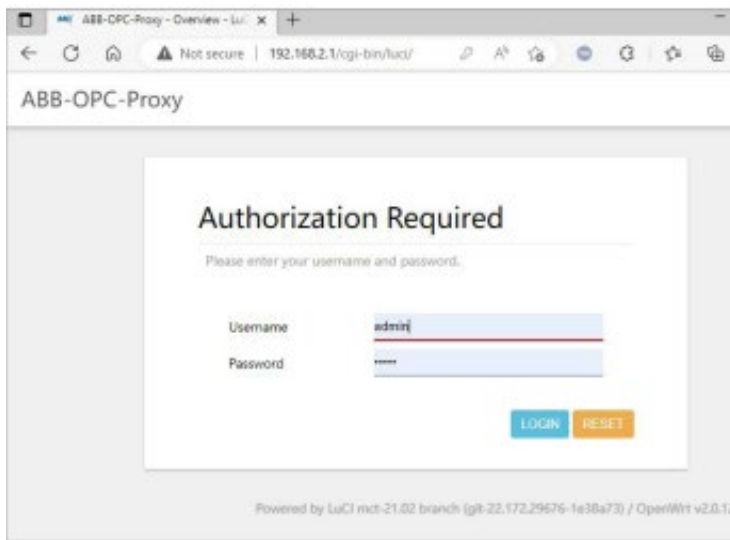

4.2. Adding Slave Devices (Modbus RTU)

The SCC supports Modbus slave devices, either Modbus RTU or Modbus TCP/IP.

- Navigate to the **Service** tab. You can find this on the left side of the portal. Go to → Modbus tab.
- Add the slave devices by specifying the **Name, Address, Baud rate, Parity, Stop Bits** and **Modbus ID** as shown below.

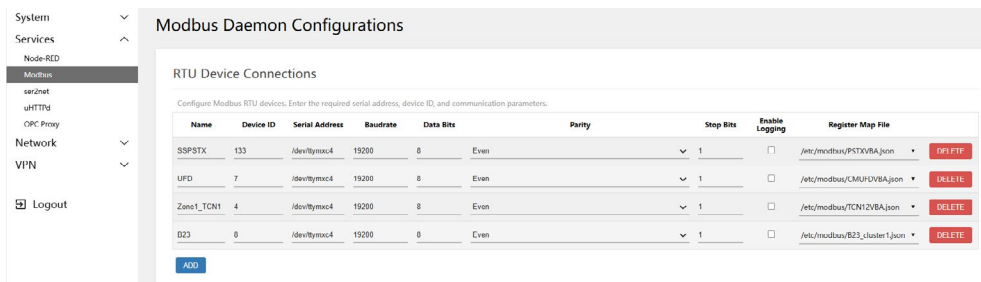

Note: You can give any recognizable name to the device. But the .Json file is already linked to its own device. For instance, if you give the name “Energy Analyzer” and linked the .Json file of the CM-TCN.012 12VBA, all the address of the CM-TCN.012 will be shown under the name Energy Analyzer.

- Import the **Register Map** file (in .Json format) from your local machine. Be on the same tab, scroll down a little bit. You will find the option to import (.Json file). Select the file you want to upload.

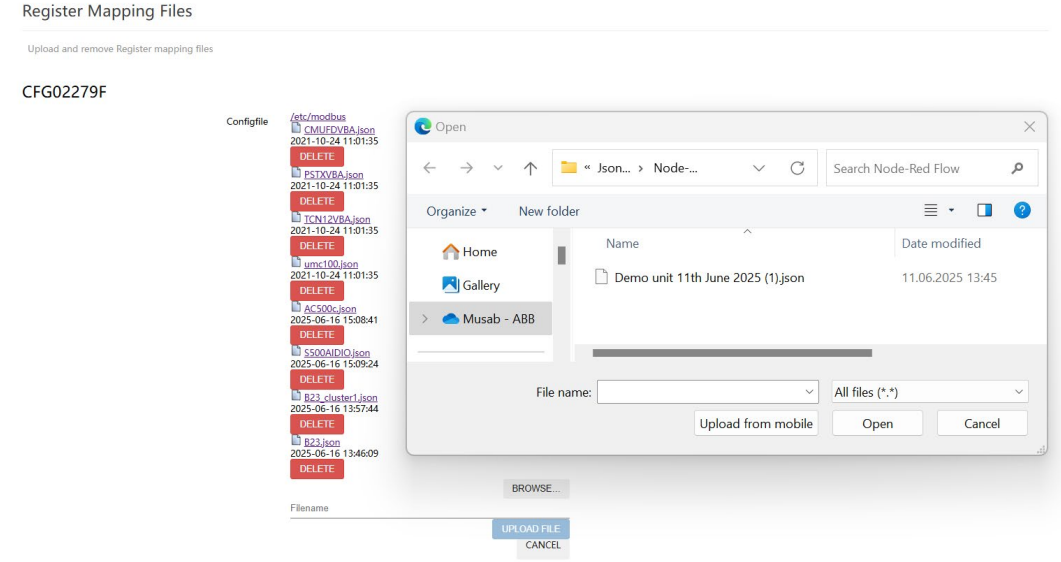

Note: After importing files, do not forget to click on save & apply button, available on right bottom. The uploaded file can be seen in the dropdown button of the “register Map file.” The file will be available in the dropdown menu after **refreshing** the explorer.

4.3. OPC UA Configuration

The OPC UA, which is also an open industrial protocol, is supported by SCC. To configure OPC UA in SCC, we need a few important certificates which ABB will provide customers with SCC card.

Follow the below-mentioned steps to configure OPC Server:

- Go to → **OPC UA** section under service tab.
- Define the correct parameters and enter the **OPC UA server URL** like this ‘opc.tcp://192.168.2.11’, which must include the IP address of the gateway. For register mapping we need to follow the same steps that we have taken in the Modbus section above.

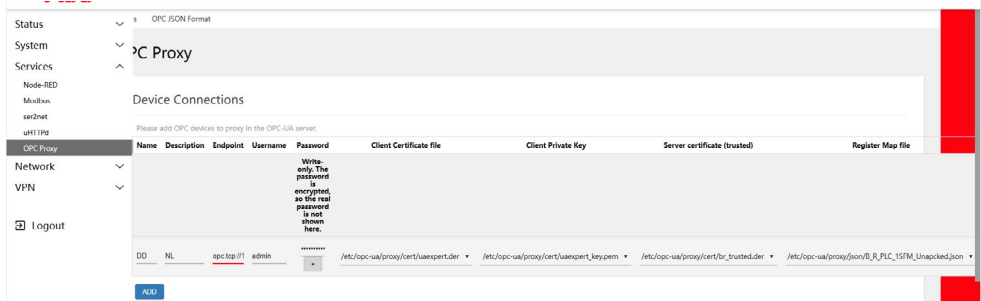

Do not forget to click on save & apply the button. Refresh the page after making changes.

4.4. Network Interface Configuration

This section is purely based on the IP address of the SCC interface and the gateway (nearest router).

- Under the Network tab **Goto** → **Interface** section, set the **Gateway IP** only to match your router's IP address



Click on the edit to change the Gateway IP, as shown below.

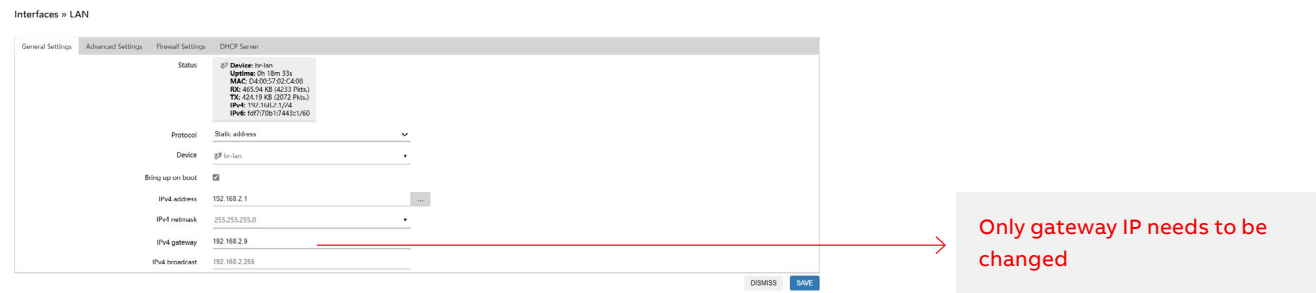

Note: Do not change the IPv4 address of the interface otherwise you have to reset or change the System's IP to get access to the portal again be careful.

5. Setting up W-Modbus devices

5.1. POWER AND RS485 CIRCUIT CAUTION

W-Modbus uses a half-wave rectified circuit. It should not share a VAC transformer with a device using full wave rectified circuit. The same VAC transformer can be used for W-Modbus and other device(s) if: The other device(s) are half-wave rectified. All power connections must have the same polarity. The "+" terminal of W-Modbus must not be connected to the "-" terminal of another device.

5.2. W-Modbus Configuration

5.2.1. Dip switch settings

Set the RS485 bus settings on the gateway (W-Modbus which is connected to SCC and acts as Master) using the dip switches. These settings will automatically be used by node (W-Modbus PRO acts as slave) in the network. You can find the dip switches setting below.

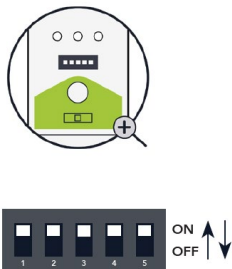

	1	2	3	4	5
9600 baud	OFF	OFF	-	-	-
19200 baud	OFF	ON	-	-	-
38400 baud	ON	OFF	-	-	-
76800 baud	ON	ON	-	-	-
No parity	-	-	OFF	-	-
Even parity	-	-	ON	-	-
1 stop bit	-	-	-	OFF	-
2 stop bit	-	-	-	ON	-
Node only: use local serial configuration					ON
Use gateway serial configuration on node					OFF

5.2.2. W-Modbus Node (PRO)

Install your W-Modbus node PRO and connect it to your Modbus slave device as shown in the above architecture. Serial bus settings are inherited from the gateway automatically. You will find the three modes on W-Modbus Gateway (Master) and Node Pro (Slave) as shown below figure. The W-Modbus (Slave) node must always be in node mode and W-Modbus (Master) must always be in gateway mode.

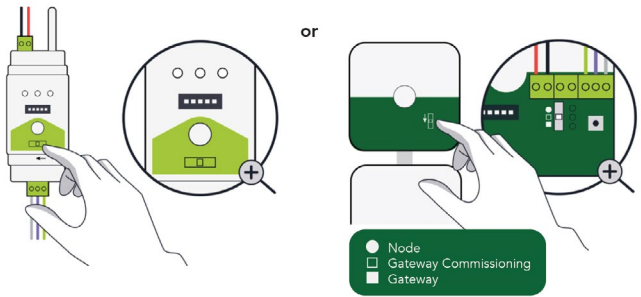

5.2.3. LED'S Behavior

- The node has successfully joined the gateway once all three LEDs start flashing from blue to green. Allow for up to 5 minutes of joining time.
- Once all three lights start flashing green, return to the gateway (Master) and flip the 3-way switch to the gateway position. This will lock and secure the network.
- All devices will flash yellow for 10 seconds and reboot. Allow up to 15 minutes for the network to be rebuilt and stabilized. The Modbus controller can now start communicating with the devices in the wireless network.
- **LED 1** is used to indicate gateway/node and network signal strength on node.
- **LED 2** is used to indicate Modbus bus activity TX/RX.
- **LED 3** is used to indicate valid communicating Modbus device(s) on the local bus

5.2.4. Validation of Data from Mobile APP

- To validate your installation using the mobile app, activate Bluetooth on the gateway (Master) by pressing the button three times. The middle LED will blink blue twice, indicating that the device is now discoverable for three minutes.
- Install the "W-Modbus" app from the play or apple store.
 - Open the app, you will find the option to "scan device". Before clicking on this option make sure you press the button three times on the gateway (Mater device).
 - You will see gateway (master) and nodes (slaves) available in your network.

—

ABB AG

STOTZ-KONTAKT

Eppelheimer Strasse 82

69123 Heidelberg

Germany

**You can find the address of your local
sales organization on the ABB homepage**

abb.com/lowvoltage



Additional information

We reserve the right to make technical changes or modify the contents of this document without prior notice. With regard to purchase orders, the agreed particulars shall prevail. ABB AG does not accept any responsibility whatsoever for potential errors or possible lack of information in this document.

We reserve all rights in this document and in the subject matter and illustrations contained therein. Any reproduction, disclosure to third parties or utilization of its contents – in whole or in parts – is forbidden without prior written consent of ABB AG.
Copyright© 2025 ABB
All rights reserved