

Synchro-check Relay

SPAU 140 C

Product Guide

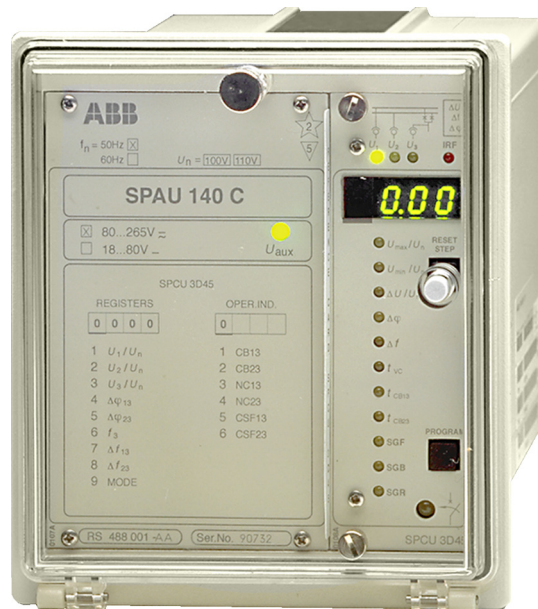

Features

- Two identical operation stages allowing the closing conditions of two separate circuit breakers to be checked
- Synchro-check function available for both operation stages
- Voltage-check function available for both operation stages
- Two different operation modes: continuous mode and command mode operation
- Numerical display of setting values, measured values and values recorded on relay operation
- Continuous auto-diagnostic self-supervision of both relay hardware and software
- Serial interface for connecting the relay to the SPA bus and higher-level host systems
- Powerful software support for parameterization of the relay, for reading measured and recorded values, events, etc., and for storing readings
- CE marking according to the EC directive for EMC

Application

The numerical synchro-check relay type SPAU 140 C is a voltage measuring relay designed to be used when two power systems are to be connected together.

The synchro-check relay SPAU 140 C can be used for both synchro-check functions and voltage-check functions. The synchro-check function is used when two separate networks

or two electrically interconnected network sections are to be connected together. The voltage-check function is used when a disconnected bus/line is to be connected to an energized section of a network. The synchro-check function allows circuit breaker closing only if the voltages on both sides of the circuit breaker fulfill the preset conditions as to magnitude, phase and frequency difference.

Design

The relay measures the magnitude, phase angle and frequency difference of the voltages on either side of the circuit breaker. The integrated synchro-check relay incorporates both a synchro-check unit and a voltage-check unit. The synchro-check unit checks the conditions when two energized networks are to be connected together and the voltage-check unit when an energized network section is to be connected with a non-energized network section.

The relay has two identical operation stages which allow the closing conditions of two separate breakers to be checked. Due to this feature the synchro-check relay can also be used in duplex switchgear.

In addition to the supervision functions the synchro-check relay incorporates data acquisition and recording functions.

Data communication

The feeder protection relay is provided with a serial interface on the rear panel. By means of a bus connection module type SPA-ZC 21 or SPA-ZC 17 the feeder protection relay can be connected to the fibre-optic SPA bus. The bus connection module SPA-ZC 21 is powered from the host relay, whereas the bus connection module type SPA-ZC 17 is provided with a built-in power unit, which can be fed from an external secured power source. The relay communicates with higher-level data acquisition and control systems over the SPA bus.

Self-supervision

The relay incorporates a sophisticated self-supervision system with auto-diagnosis, which increases the availability of the relay and the reliability of the system. The self-supervision system continuously monitors the hardware and the software of the relay. The system also supervises the operation of the auxiliary supply module and the voltages generated by the module.

When permanent internal relay fault is detected, the IRF indicator on the relay front panel is lit. At the same time the output relay of the self-supervision system operates and a fault message is transmitted to the higher-level system over the serial bus. Further, in most fault situations, a fault code is shown in the display of the protection relay module. The fault code indicates the type of the fault that has been detected.

Auxiliary supply voltage

The auxiliary supply of the relay is obtained from an internal plug-in type power supply module. Two auxiliary power module versions are available: type SPTU 240R4 for the supply voltage range 80...265 V ac/dc and type SPTU 48R4 for the supply voltage range 18...80 V dc. The power supply module forms the internal voltages required by the protection relay and the I/O module.

Technical data

Table 1: Energizing inputs

Terminals	13-14, 16-17, 19-20	13-15, 16-18, 19-21
Rated voltage U_n	100 V	110 V
Continuous voltage withstand	$2.0 \times U_n$	
Burden at rated voltage	<0.5 VA	
Permitted frequency range	45...65 Hz	
Rated frequency f_n , according to order	50 Hz or 60 Hz	

Table 2: Output contact ratings

Type of contact		Heavy-duty	Signalling
Terminals		85-86, 87-88	70-71-72, 68-69
Rated voltage		250 V ac/dc	
Thermal withstand capability	Carry continuously	5 A	5 A
	Make and carry for 0.5 s	30 A	10 A
	Make and carry for 3 s	15 A	8 A
Breaking capacity for dc, when the control circuit time constant $L/R \leq 40$ ms, at the control voltage levels	220 V dc	1 A	0.15 A
	110 V dc	3 A	0.25 A
	48 V dc	5 A	1 A

Table 3: External control input

Blocking and control inputs	10-11, 22-23, 45-46, 47-48
External control voltage level	18...265 V dc or 80...265 V ac
Typical control current of activated input circuit	2...20 mA

Table 4: Data communication

Transmission mode	Fibre-optic serial bus	
Data code	ASCII	
Transfer rates, selectable	4800 or 9600 Bd	
Optional bus connection module, powered from an external power source	for plastic core cables	SPA-ZC 17BB
	for glass fibre cables	SPA-ZC 17MM
Optional bus connection module, powered from the host relay	for plastic core cables	SPA-ZC 21BB
	for glass fibre cables	SPA-ZC 2 MM

Table 5: Auxiliary supply modules

Supply and output relay module SPTU 240R4	operative voltage range	80...265 V ac/dc
Supply and output relay module SPTU 48R4	operative voltage range	18...80 V dc
Power consumption, quiescent/operation conditions		~5 W/~7 W

Technical data (cont'd)

Table 6: Synchro-check relay module SPCU 3D45

Synchro-check function	Upper threshold voltage, U_{max}	Setting range	$0.5...1.0 \times U_n$
		Resolution	$0.01 \times U_n$
	Voltage difference, ΔU	Setting range	$0.02...0.4 \times U_n$
		Resolution	$0.01 \times U_n$
	Phase angle difference, $\Delta\varphi$	Setting range	$5...50^\circ$
		Resolution	1°
	Frequency difference, Δf	Setting range	$0.02...0.25$ Hz
Resolution		0.01 Hz	
Operate time of circuit breakers, t_{CB13} and t_{CB23}	Setting range	$0.05...0.25$ s	
	Resolution	0.01 s	
Measuring time when energizing voltage increases from 0 V to U_n , fixed value		160 ms ± 20 ms	
Voltage-check function	Upper threshold voltage, U_{max}	Setting range	$0.5...1.0 \times U_n$
		Resolution	$0.01 \times U_n$
	Lower threshold voltage, U_{min}	Setting range	$0.1...0.8 \times U_n$
		Resolution	$0.01 \times U_n$
	Operate time (dead time) of voltage-check function, t_{VC}	Setting range	$0.1...20$ s
		Resolution	0.01 s
	Selectable energizing directions	Stage 1	both "cold" or U1→U3 or U1←U3 U1→U3 U1←U3 U1→U3 or U1←U3
Stage 2		both "cold" or U2→U3 or U2←U3 U2→U3 U2←U3 U2→U3 or U2←U3	
Operation mode		Command or continuous mode	
Command mode operation	Length of CB closing signal, t_{pulse}	Setting range	$0.2...20$ s
		Resolution	0.01 s
	Check time during which closing is permitted, t_{check}	Setting range	$0.05...300$ s
		Resolution	0.01 s

Technical data (cont'd)

Table 7: Tests and standards

Test voltages	Dielectric test voltage (IEC 60255-5)	2.0 kV, 50 Hz, 1 min
	Impulse test voltage (IEC 60255-5)	5 kV, 1.2/50 μ s, 0.5 J
	Insulation resistance voltage (IEC 60255-5)	>100 M Ω , 500 V dc
Interference tests	High-frequency (1 MHz) disturbance test (IEC 60255-22-1), common mode	2.5 kV
	High-frequency (1 MHz) disturbance test (IEC 60255-22-1), differential mode	1.0 kV
	Fast transients (IEC 60255-22-4, class III and IEC 61000-4-4), power supply inputs	4 kV, 5/50 ns
	Fast transients (IEC 60255-22-4, class III and IEC 61000-4-4), other inputs	2 kV, 5/50 ns
	Electrostatic discharge (IEC 60255-22-2 and IEC 61000-4-2), air discharge	8 kV
	Electrostatic discharge (IEC 60255-22-2 and IEC 61000-4-2), contact discharge	6 kV
	Environmental conditions	Specified ambient service temperature range
Transport and storage temperature range		-40...+70°C
Temperature influence on the operate values of the relay over the specified ambient service temperature range		<0.1%/°C
Long term damp heat withstand (IEC 60068-2-3)		<95%, +40°C, 96 h
Degree of protection by enclosure of the relay case (according to IEC 60529) when the relay is panel-mounted		IP 54
Weight		~3 kg

Block diagram

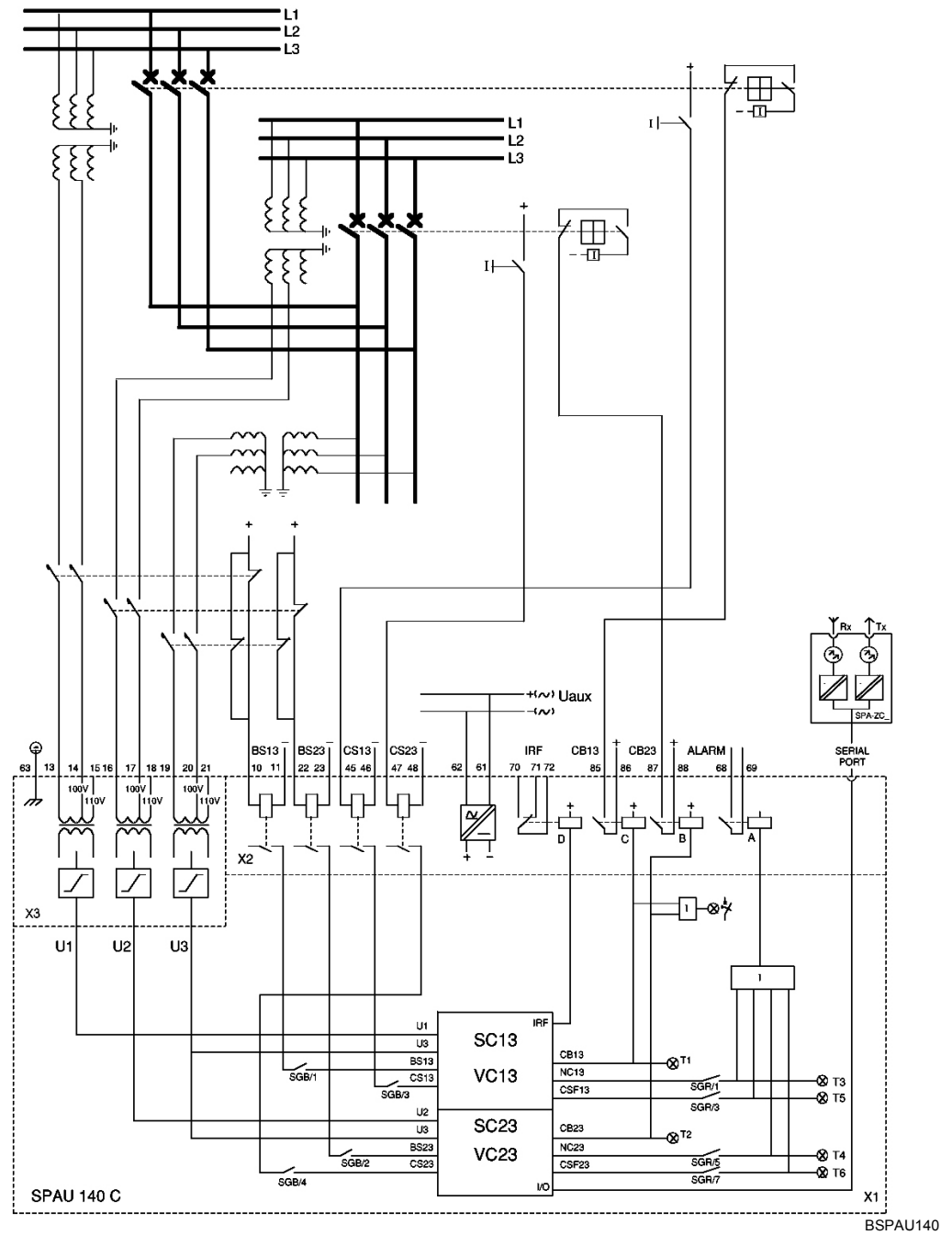

Fig. 1 Block diagram and sample connection diagram

Mounting and dimensions

Flush mounting

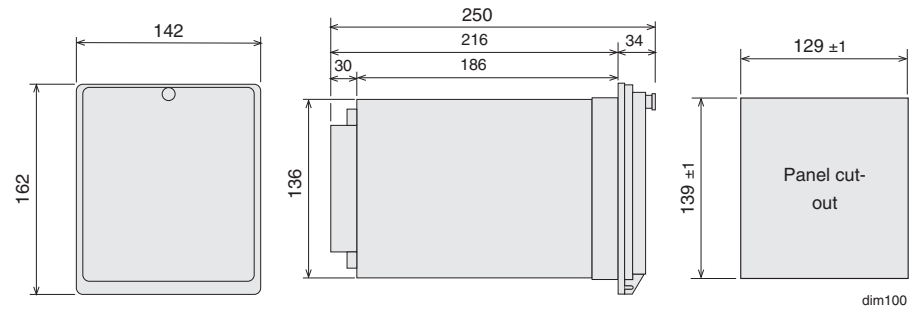

Fig. 2 Flush-mounting relay case (dimensions in mm)

Semi-flush mounting

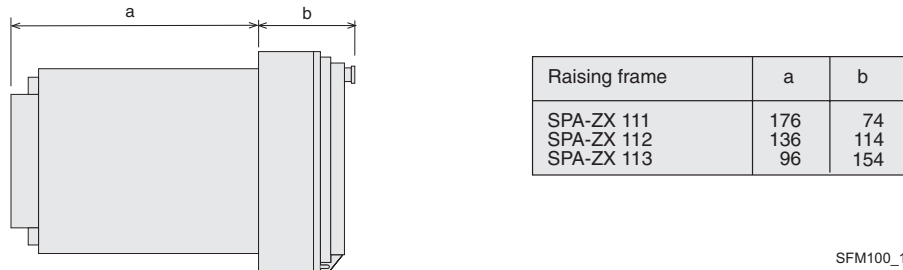

Fig. 3 Semi-flush mounting relay case (dimensions in mm)

Mounting in 19 inch cabinets and frames

An ancillary mounting plate, height 4U (~177 mm), is recommended to be used when the protection relays are to be mounted in 19 inch frames or cabinets. The ancillary mounting plate type SPA-ZX 104 accommodates three relays, type SPA-ZX 105 two relays and type SPA-ZX 106 one relay.

Projecting mounting

When projecting mounting is preferred, a relay case type SPA-ZX 110 is used. The relay case for projecting mounting is provided with front connectors.

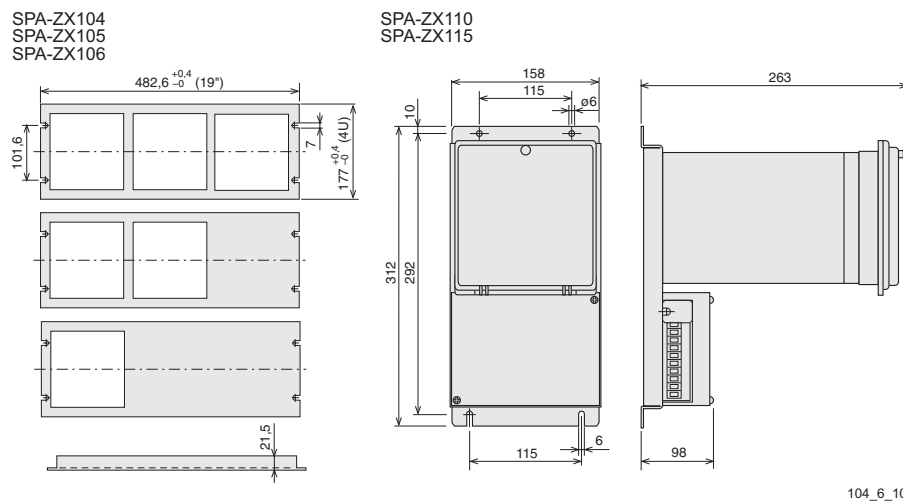

Fig. 4 Mounting cabinets and frames as well as projecting mounting (dimensions in mm)

Ordering

When ordering, please specify:

Ordering information	Ordering example
1. Type designation and quantity	SPAU 140 C, 5 pieces
2. Order number	RS 488 001-AA
3. Rated values	$U_n = 110 \text{ V}$, $f_n = 50 \text{ Hz}$
4. Auxiliary voltage	$U_{aux} = 110 \text{ V dc}$
5. Accessories	-
6. Special requirements	-

Order numbers

Synchro-check relay SPAU 140 C without test adapter	RS 488 001-AA, CA, DA, FA
Synchro-check relay SPAU 140 C including test adapter RTXP 18	RS 488 201-AA, CA, DA, FA
The last two letters of the order number indicate the rated frequency f_n and the auxiliary voltage U_{aux} of the relay as follows:	AA equals $f_n = 50 \text{ Hz}$ and $U_{aux} = 80 \dots 265 \text{ V ac/dc}$
	CA equals $f_n = 50 \text{ Hz}$ and $U_{aux} = 18 \dots 80 \text{ V dc}$
	DA equals $f_n = 60 \text{ Hz}$ and $U_{aux} = 80 \dots 265 \text{ V ac/dc}$
	FA equals $f_n = 60 \text{ Hz}$ and $U_{aux} = 18 \dots 80 \text{ V dc}$

References

Additional information

Manual "Synchro-check relay SPAU 140 C"	1MRS 750315-MUM EN
-----------------------------------------	--------------------



ABB Oy

Distribution Automation

P.O. Box 699

FI-65101 Vaasa, FINLAND

Tel +358 10 22 11

Fax +358 10 224 1094

www.abb.com/substationautomation