

---

ABB GENERAL PURPOSE DRIVES

# ACP510-01 drives (0.75 to 250 kW)

## Hardware manual





# ACP510-01 drives (0.75 to 250 kW)

## Hardware manual

Table of contents



1. Safety instructions



4. Mechanical installation



5. Guidelines for planning the electrical installation



6. Electrical installation-IEC



3AXD50001148140 Rev B  
EN

Original instructions  
EFFECTIVE: 2024-08-30



# Table of contents

---

## 1 Safety instructions

Contents of this chapter .....	17
Use of warnings and notes .....	17
General safety in installation, start-up and maintenance .....	18
General safety in operation .....	19
Electrical safety in installation, start-up and maintenance .....	20
Electrical safety precautions .....	20
Additional instructions and notes .....	21
Printed circuit boards .....	22
Grounding .....	22

## 2 Introduction to the manual

Contents of this chapter .....	23
Applicability .....	23
Target audience .....	23
Purpose of the manual .....	23
Categorization by frame size .....	24
Quick installation and commissioning flowchart .....	24
Terms and abbreviations .....	25
Related documents .....	26

## 3 Operation principle and hardware description

Contents of this chapter .....	27
Operation principle .....	28
Layout .....	29
Overview of power and control connections .....	35
External control connection terminals, frames R1...R5 .....	36
External control connection terminals, frames R6...R9 .....	37
Control Panel (optional) .....	38
Control panel door mounting kits .....	38
Type designation label .....	39
Locations of the labels on the drive .....	40
Type designation key .....	40
Option codes .....	41

## 4 Mechanical installation

Contents of this chapter .....	43
--------------------------------	----

---



## 6 Table of contents

Safety .....	43
Examining the installation site .....	43
Installation alternatives .....	44
Necessary tools .....	48
Moving the drive .....	48
Unpacking and examining delivery, frames R1 and R2 .....	49
Unpacking and examining delivery, frame R3 .....	51
Unpacking and examining delivery, frames R4 .....	53
Unpacking and examining delivery, frame R5 .....	54
Unpacking and examining delivery, frames R6...R9 .....	56
Installing the drive .....	58
Installing the drive vertically, frames R1...R4 .....	58
Installing the drive vertically, frame R5 .....	60
Installing the drive vertically, frames R6...R9 .....	61
Installing the drive vertically side by side .....	63
Installing the drive horizontally, frames R1...R5 .....	63

## 5 Guidelines for planning the electrical installation

Contents of this chapter .....	65
Limitation of liability .....	65
Selecting the main supply disconnecting device .....	65
European Union .....	66
Other regions .....	66
Examining the compatibility of the motor and drive .....	66
Protecting the motor insulation and bearings .....	66
Requirements table .....	67
Availability of $du/dt$ filter and common mode filter by drive type .....	69
Additional requirements for explosion-safe (EX) motors .....	69
Additional requirements for ABB motors of types other than M2_, M3_, M4_, HX_ and AM_ .....	69
Additional requirements for braking applications .....	69
Additional requirements for ABB high-output and IP23 motors ..	69
Additional requirements for non-ABB high-output and IP23 motors .....	69
Additional data for calculating the rise time and the peak line-to-line voltage .....	70
Additional note for sine filters .....	71
Selecting the power cables .....	72
General guidelines .....	72
Typical power cable sizes .....	72
Power cable types .....	72
Preferred power cable types .....	72
Alternate power cable types .....	73
Not allowed power cable types .....	74

Power cable shield .....	74
Grounding requirements .....	75
Additional grounding requirements – IEC .....	76
Selecting the control cables .....	77
Shielding .....	77
Signals in separate cables .....	77
Signals that can be run in the same cable .....	77
Relay cable .....	77
Control panel to drive cable .....	77
PC tool cable .....	78
FPBA-01 PROFIBUS DP adapter module connectors .....	78
Routing the cables .....	78
General guidelines – IEC .....	78
Continuous motor cable shield/conduit or enclosure for equipment on the motor cable .....	79
Separate control cable ducts .....	80
Implementing short-circuit and thermal overload protection .....	80
Protecting the drive and the input power cable in short-circuits .....	80
Protecting the motor and motor cable in short-circuits .....	81
Protecting the motor cables against thermal overload .....	81
Protecting the motor against thermal overload .....	81
Protecting the motor against overload without thermal model or temperature sensors .....	82
Protecting the drive against ground faults .....	82
Residual current device compatibility .....	82
Implementing the emergency stop function .....	82
Implementing the Safe torque off function .....	82
Using power factor compensation capacitors with the drive .....	83
Controlling a contactor between drive and motor .....	83
Implementing a bypass connection .....	83
Example bypass connection .....	84
Switching the motor power supply from drive to direct-on-line .	85
Switching the motor power supply from direct-on-line to drive .	85
Protecting the contacts of relay outputs .....	85
Limiting relay output maximum voltages at high installation altitudes .....	86
Implementing a motor temperature sensor connection .....	86
Connecting a motor temperature sensor to the drive through an option module .....	87

## 6 Electrical installation-IEC

Contents of this chapter .....	89
Required tools .....	89
Grounding the motor cable shield at the motor end .....	90
Measuring the insulation .....	90
Measuring the insulation resistance of the drive .....	90

## 8 Table of contents

Measuring the insulation resistance of the input power cable .....	90
Measuring the insulation resistance of the motor and motor cable .....	90
Brake resistor assembly for R1...R3 .....	91
Grounding system compatibility check .....	91
EMC filter .....	92
Ground-to-phase varistors .....	92
When to disconnect EMC filter or ground-to-phase varistor: TN-S, IT, corner-grounded delta and midpoint-grounded delta systems .....	92
Guidelines for installing the drive to a TT system .....	94
Identifying the grounding system of the electrical power network .....	95
Disconnecting internal EMC filter or ground-to-phase varistor - frames R1...R3 .....	96
Disconnecting internal EMC filter or ground-to-phase varistor - frames R4...R9 .....	97
Connecting the power cables .....	99
Connection diagram .....	99
Connection procedure, frames R1...R4 .....	100
Motor cable .....	102
Input power cable .....	103
Brake resistor cable (if used) .....	105
Finalization .....	106
Connection procedure, frame R5 .....	106
Motor cable .....	108
Input power cable .....	109
Finalization .....	111
Connection procedure, frames R6...R9 .....	112
Input power cable .....	113
Detaching and reinstalling the connectors .....	114
DC connection .....	115
Connecting the control cables .....	116
Connection diagram .....	116
Control cable connection procedure R1...R9 .....	116
Installing option modules .....	122
Option slot 2 (I/O extension modules) .....	122
Option slot 1 (fieldbus adapter modules) .....	123
Wiring the optional modules .....	123
Reinstalling covers .....	124
Reinstalling cover, frames R1...R4 .....	124
Reinstalling covers, frame R5...R9 .....	124
Connecting a PC .....	125
Connecting a remote panel, or chaining one panel to several drives .....	126

## 7 Control unit

Contents of this chapter .....	127
--------------------------------	-----



Layout .....	128
CCU-23 (R1...R5) .....	128
CCU-24 (R6...R9) .....	129
Default I/O connection diagram .....	131
Default I/O connection diagram .....	131
Additional information on I/O connections .....	136
Embedded EIA-485 fieldbus connection .....	136
Connecting motor temperature sensors to the drive .....	137
PNP configuration for digital inputs (DIGITAL IN) .....	138
NPN configuration for digital inputs (DIGITAL IN) .....	139
Connection for obtaining 0...10 V from analog output 2 (AO2) .....	139
Connection examples of two-wire and three-wire sensors to analog input (AI2) .....	140
DI5 as frequency input .....	140
Safe torque off (X4) .....	140
Technical data .....	141

## 8 Installation checklist

Contents of this chapter .....	149
Checklist .....	149

## 9 Maintenance

Contents of this chapter .....	153
Maintenance intervals .....	153
Description of symbols .....	153
Recommended maintenance intervals after start-up .....	154
Cleaning the exterior of the drive .....	155
Cleaning the heatsink .....	155
Fans .....	156
Replacing the main cooling fan, IP20 frames R1...R4 .....	157
R1...R3 .....	157
R4 .....	158
Replacing the main cooling fan, IP20 frames R5...R8 .....	159
Replacing the main cooling fans, IP20 frame R9 .....	160
Replacing the auxiliary cooling fan, IP20 frames R6...R9 .....	161
Replacing the auxiliary cooling fan, IP20 frame R5 .....	162
Capacitors .....	163
Reforming the capacitors .....	163
Control Panel .....	163
Cleaning the control panel .....	163
LEDs .....	164
Drive LEDs .....	164
Control panel LEDs .....	165
Functional safety components .....	166



**10 Technical data**

Contents of this chapter ..... 167

Ratings ..... 167

    IEC ..... 167

        Definitions ..... 168

    Sizing ..... 169

    Derating ..... 169

        Surrounding air temperature derating, IP20 ..... 170

        Altitude derating ..... 171

        Switching frequency derating by derating factor ..... 172

        Switching frequency derating with actual output current values ..... 173

        Output frequency derating ..... 174

Fuses (IEC) ..... 175

    gG fuses ..... 175

    uR and aR fuses ..... 176

Circuit breakers (IEC) ..... 178

Dimensions, weights and free space requirements ..... 180

Losses, cooling data and noise ..... 181

    Cooling air flow, heat dissipation and noise for stand-alone drives ..... 181

        IEC ..... 182

Terminal and lead-through data for the power cables ..... 183

    IEC ..... 183

Power cables ..... 184

    Typical power cable sizes, IEC ..... 184

Terminal and lead-through data for the control cables ..... 186

    IEC ..... 186

Electrical power network specification ..... 186

Motor connection data ..... 189

Brake resistor connection data for frames R1..R3 ..... 191

Auxiliary circuit power consumption ..... 191

Efficiency ..... 192

Energy efficiency data (ecodesign) ..... 192

Ecodesign ..... 192

Protection classes for module ..... 192

Applicable standards ..... 193

Ambient conditions ..... 194

Storage conditions ..... 195

Colors ..... 195

Markings ..... 196

CE marking ..... 196

    Compliance with the European Low Voltage Directive ..... 196

    Compliance with the European EMC Directive ..... 196

    Compliance with the European ROHS II Directive 2011/65/EU ..... 197

    Compliance with the European WEEE Directive 2002/96/EC ..... 197



Compliance with the European Machinery Directive 2006/42/EC	
2nd Edition – June 2010 .....	197
Validating the operation of the Safe torque off function .....	197
Compliance with the EN 61800-3 .....	197
Definitions .....	197
Category C1 .....	198
Category C2 .....	198
Category C3 .....	199
Category C4 .....	199
Disclaimers .....	200
Generic disclaimer .....	200
Cyber security disclaimer .....	200

## 11 Dimension drawings

Contents of this chapter .....	201
Frame R1, IP20 .....	202
Frame R2, IP20 .....	203
Frame R3, IP20 .....	204
Frame R4, IP20 .....	205
Frame R5, IP20 .....	206
Frame R6, IP20 .....	207
Frame R7, IP20 .....	208
Frame R8, IP20 .....	209
Frame R9, IP20 .....	210

## 12 Resistor braking

Contents of this chapter .....	211
Operation principle and hardware description .....	211
Resistor braking, frames R1...R3 .....	211
Planning the braking system .....	211
Selecting the brake resistor .....	211
Selecting and routing the brake resistor cables .....	213
Placing the brake resistor .....	214
Protecting the system in brake circuit fault situations .....	214
Mechanical installation .....	215
Electrical installation .....	215
Start-up .....	216
Start-up .....	216
Resistor braking, frames R4...R9 .....	216
Planning the braking system .....	216
IEC .....	216
Parameter settings for external braking chopper and resistor .....	217

### 13 The Safe torque off function

Contents of this chapter .....	219
Description .....	219
Compliance with the European Machinery Directive .....	220
Wiring .....	221
Connection principle .....	221
Single ACP510-01 drive, internal power supply .....	221
Single ACP510-01 drive, external power supply .....	222
Wiring examples .....	222
Single ACP510-01 drive, internal power supply .....	222
Single ACP510-01 drive, external power supply .....	223
Multiple ACP510-01 drives, internal power supply .....	224
Multiple ACP510-01 drives, external power supply .....	225
Activation switch .....	226
Cable types and lengths .....	226
Grounding of protective shields .....	226
Operation principle .....	227
Start-up including validation test .....	228
Competence .....	228
Validation test reports .....	228
Validation test procedure .....	228
Use .....	230
Maintenance .....	231
Competence .....	231
Fault tracing .....	232
Safety data .....	233
Terms and abbreviations .....	235
TÜV certificate .....	236
Declarations of conformity .....	237

### 14 Optional I/O extension and adapter modules

Contents of this chapter .....	239
CAIO-01 bipolar analog I/O adapter module .....	239
Product overview .....	239
Layout .....	240
Mechanical Installation .....	241
Necessary tools .....	241
Unpacking and examining the delivery .....	241
Installing the module .....	241
Electrical installation .....	241
Necessary tools .....	241
Wiring .....	241
Start-up .....	242
Setting the parameters .....	242



Diagnostics .....	243
LEDs .....	243
Technical data .....	244
Isolation areas .....	245
Dimension drawings .....	246
CBAI-01 bipolar analog IO adapter module .....	246
Product overview .....	246
Layout .....	247
Mechanical Installation .....	247
Necessary tools .....	247
Unpacking and examining the delivery .....	248
Installing the module .....	248
Electrical installation .....	248
Necessary tools .....	248
Wiring .....	248
Start-up .....	249
Setting the parameters .....	249
Diagnostics .....	249
LEDs .....	249
Technical data .....	249
Isolation areas .....	251
Dimension drawing .....	251
CHDI-01 115/230 V digital input extension module .....	252
Product overview .....	252
Layout and connection examples .....	253
Mechanical Installation .....	254
Necessary tools .....	254
Unpacking and examining the delivery .....	254
Installing the module .....	254
Electrical installation .....	254
Necessary tools .....	254
Wiring .....	254
Start-up .....	254
Setting the parameters .....	254
Fault and warning messages .....	255
Technical data .....	255
Isolation areas .....	256
Dimension drawing .....	257
CMOD-01 multifunction extension module (external 24 V AC/DC and digital I/O) .....	257
Product overview .....	257
Layout and example connections .....	258
Mechanical Installation .....	259
Necessary tools .....	259
Unpacking and examining the delivery .....	259



## 14 Table of contents

Installing the module .....	259
Electrical installation .....	260
Necessary tools .....	260
Wiring .....	260
Start-up .....	260
Setting the parameters .....	260
Diagnostics .....	261
Technical data .....	262
Isolation areas .....	263
Dimension drawing .....	264
CMOD-02 multifunction extension module (external 24 V AC/DC and isolated PTC interface) .....	264
Product overview .....	264
Layout and example connections .....	265
Mechanical Installation .....	266
Necessary tools .....	266
Unpacking and examining the delivery .....	266
Installing the module .....	267
Electrical installation .....	267
Necessary tools .....	267
Wiring .....	267
Start-up .....	267
Setting the parameters .....	267
Diagnostics .....	267
Faults and warning messages .....	267
LEDs .....	268
Technical data .....	268
Isolation areas .....	269
Dimension drawing .....	270

## 15 Common mode, du/dt and sine filters

Content of this chapter .....	271
Common mode filters .....	271
When is a common mode filter needed? .....	271
Common mode filter types .....	271
IEC ratings at $U_n = 400$ V .....	271
du/dt filters .....	272
When is a du/dt filter needed? .....	272
du/dt filter types .....	272
IEC ratings at $U_n = 400$ V .....	272
Description, installation and technical data of the FOCH filters .....	273
Description, installation and technical data of the NOCH filters .....	273
Sine filters .....	273
IEC ratings at $U_n = 400$ and 480 V .....	273
Description, installation and technical data .....	274

## Further information





# 1

## Safety instructions

---

### Contents of this chapter

This chapter contains the safety instructions which you must obey when you install, start-up, operate and do maintenance work on the drive. If you ignore the safety instructions, injury, death or damage can occur.



### Use of warnings and notes

Warnings tell you about conditions which can cause injury or death, or damage to the equipment. They also tell you how to prevent the danger. Notes show a particular condition or fact, or give information.

The manual uses these warning symbols:

**WARNING!**

Electricity warning tells about hazards from electricity which can cause injury or death, or damage to the equipment.

---

**WARNING!**

General warning tells about conditions other than those caused by electricity, which can cause injury or death, or damage to the equipment.

---

**WARNING!**

Electrostatic sensitive devices warning tells you about the risk of electrostatic discharge which can cause damage to the equipment.

---

## General safety in installation, start-up and maintenance

These instructions are for all persons who do work on the drive.

**WARNING!** Obey these instructions. If you ignore them, injury or death, or damage to the equipment can occur.

- Keep the drive in its package until you install it. After unpacking, protect the drive from dust, debris and moisture.
- Use the required personal protective equipment: safety shoes with metal toe cap, safety glasses, protective gloves and long sleeves, etc. Some parts have sharp edges.
- Use a lifting device to lift a heavy drive. Use the designated lifting points. Refer to the dimension drawings.
- Be careful when handling a tall module. The module overturns easily because it is heavy and has a high center of gravity. Whenever possible, secure the module with chains. Do not leave an unsupported module unattended especially on a sloping floor.



- Beware of hot surfaces. Some parts, such as heatsinks of power semiconductors, and brake resistors, remain hot for a while after disconnection of the electrical supply.
- Vacuum clean the area around the drive before the start-up to prevent the drive cooling fan from drawing the dust inside the drive.
- Make sure that debris from drilling, cutting and grinding does not enter the drive during the installation. Electrically conductive debris inside the drive may cause damage or malfunction.
- Make sure that there is sufficient cooling. See the technical data.
- Before you connect voltage to the drive, make sure that all covers are in place. Do not remove the covers when voltage is connected.

- Before you adjust the drive operation limits, make sure that the motor and all driven equipment can operate throughout the set operation limits.
- Before you activate the automatic fault reset or automatic restart functions of the drive control program, make sure that no dangerous situations can occur. These functions reset the drive automatically and continue operation after a fault or supply break. If these functions are activated, the installation must be clearly marked as defined in IEC/EN 61800-5-1, subclause 6.5.3, for example, "THIS MACHINE STARTS AUTOMATICALLY".
- The maximum drive power cycle is five times in ten minutes. Power cycling the drive too often can damage the charging circuit of the DC capacitors.
- If you have connected safety circuits to the drive (for example, Safe torque off or emergency stop), validate them at start-up. See separate instructions for the safety circuits.
- Beware of hot air exiting from the air outlets.
- Do not cover the air inlet or outlet when the drive is running.

**Note:**

- If you select an external source for the start command and it is on, the drive will start immediately after fault reset unless you configure the drive for pulse start. See the firmware manual.
- If the drive is in remote control mode, you cannot stop or start the drive with the control panel.
- Only authorized persons are allowed to repair a malfunctioning drive.



## General safety in operation

These instructions are for all personnel that operate the drive.

---

**WARNING!**

Obey these instructions. If you ignore them, injury or death, or damage to the equipment can occur.

---

- If you have a cardiac pacemaker or other electronic medical device, do not go near the motor, drive, and the drive power cabling when the drive is in operation. The equipment produces electromagnetic fields that can cause interference in electronic medical devices. This can cause a health hazard.
  - Give a stop command to the drive before you reset a fault. If you have an external source for the start command and the start is on, the drive will start
-

immediately after the fault reset, unless you configure the drive for pulse start. See the firmware manual.

- Before you activate the automatic fault reset or automatic restart functions of the drive control program, make sure that no dangerous situations can occur. These functions reset the drive automatically and continue operation after a fault or supply break.

**Note:**

- The maximum drive power cycle is five times in ten minutes. Power cycling the drive too often can damage the charging circuit of the DC capacitors. If you need to start or stop the drive, use the control panel keys or commands through the I/O terminals of the drive.
- If the drive is in remote control mode, you cannot stop or start the drive with the control panel.

## Electrical safety in installation, start-up and maintenance

### ■ Electrical safety precautions



These electrical safety precautions are for all persons who do work on the drive, motor cable or motor.



**WARNING!**

Obey these instructions. If you ignore them, injury or death, or damage to the equipment can occur. If you are not a qualified electrical professional, do not do electrical installation or maintenance work. Do these steps before you do installation or maintenance work.

1. Prepare for the work.
  - Make sure that you have a work order.
  - Do an on-site risk assessment or job hazard analysis.
  - Make sure that you have the correct tools available.
  - Make sure that the workers are qualified.
  - Select the correct personal protective equipment (PPE).
  - Stop the drive and motor(s).
2. Clearly identify the work location and equipment.
3. Disconnect all possible voltage sources. Make sure that connection is not possible. Lock out and tag out.
  - Open the main disconnecting device of the drive.
  - If a permanent magnet motor connects to the drive, disconnect the motor from the drive with a safety switch or by other means.
  - Open the main isolating device of the drive.

- Disconnect all dangerous external voltages from the control circuits.
  - After you disconnect power from the drive, wait 5 minutes to let the intermediate circuit capacitors discharge before you continue.
4. Protect other energized parts in the work location against contact and take special precautions when close to bare conductors.
  5. Measure that the installation is de-energized. Use a high-quality voltage tester.
    - Before and after you measure the installation, verify the operation of the voltage tester on a known voltage source.
    - Make sure that the voltage between the input power terminals of the drive (L1, L2, L3) and the grounding (PE) busbar is zero.
    - Make sure that the voltage between the output power terminals of the drive (U, V, W) and the grounding (PE) busbar is zero.
    - Make sure that the voltage between the drive DC terminals (UDC+ and UDC-) and the grounding (PE) terminal is zero.
- Note:** If cables are not connected to the drive DC terminals, measuring the voltage from the DC terminal screws can give incorrect results.
6. Install temporary grounding as required by the local regulations.
  7. Ask for a permit to work from the person that is responsible for the electrical installation work.

### ■ Additional instructions and notes



#### **WARNING!**

Obey these instructions. If you ignore them, injury or death, or damage to the equipment can occur.

If you are not a qualified electrical professional, do not do installation or maintenance work.

- Make sure that the electrical power network, motor/generator, and environmental conditions agree with the drive data.
- Do not do insulation or voltage withstand tests on the drive.
- If you have a cardiac pacemaker or other electronic medical device, do not go near the motor, drive, and the drive power cabling when the drive is in operation. The equipment produces electromagnetic fields that can cause interference in electronic medical devices. This can cause a health hazard.

#### **Note:**

- When the drive is connected to the input power, the motor cable terminals and the DC bus are at a dangerous voltage.  
The brake circuit, including the brake chopper and brake resistor (if installed) are also at a dangerous voltage.



## 22 Safety instructions

After disconnecting the drive from the input power, these remain at a dangerous voltage until the intermediate circuit capacitors have discharged.

- External wiring can supply dangerous voltages to the relay outputs of the control units of the drive.
- The Safe torque off function does not remove the voltage from the main and auxiliary circuits. The function is not effective against deliberate sabotage or misuse.

### Printed circuit boards

---



#### **WARNING!**

Use ESD wristband when you handle printed circuit boards. Do not touch the boards unnecessarily. The boards are sensitive to electrostatic discharge.

---

### ■ Grounding

These instructions are for all persons who are responsible for the grounding of the drive.

---



#### **WARNING!**

Obey these instructions. If you ignore them, injury or death, or equipment malfunction can occur, and electromagnetic interference can increase.

If you are not a qualified electrical professional, do not do grounding work.

---

- Always ground the drive, the motor and adjoining equipment. This is necessary for personnel safety.
  - Make sure that the conductivity of the protective earth (PE) conductors is sufficient and that other requirements are met. Refer to the electrical planning instructions of the drive. Obey the applicable national and local regulations.
  - When you use shielded cables, make a 360° grounding of the cable shields at the cable entries to reduce electromagnetic emission and interference.
  - In a multiple-drive installation, connect each drive separately to the protective earth (PE) busbar of the power supply.
- 



# 2

## Introduction to the manual

---

### Contents of this chapter

This chapter describes the intended audience and contents of the manual. It contains a flowchart of steps in examining the delivery, installing and commissioning the drive. The flowchart refers to chapters/sections in this manual and other manuals.

### Applicability

This manual applies to the ACP510-01 drives.

### Target audience

This manual is intended for people who plan the installation, install, commission, and do maintenance work on the drive, or create instructions for the end user of the drive concerning the installation and maintenance of the drive.

Read the manual before you do work on the drive. You are expected to know the fundamentals of electricity, wiring, electrical components, and electrical schematic symbols.

### Purpose of the manual

This manual provides information needed for planning the installation, installing, and servicing the drive.

---

## Categorization by frame size

The ACP510-01 is manufactured in frames (frame sizes) R1...R9. Some instructions and other information that concern only certain frames are marked with the symbol of the frame (R1...R9). The frame is marked on the type designation label of the drive, see type designation label.

## Quick installation and commissioning flowchart

Task	See
Identify the frame of your drive: R1...R9.	<a href="#">Type designation label (page 39)</a>
↓	
Plan the installation: select the cables, etc. Examine the ambient conditions, ratings and required cooling air flow.	<a href="#">Guidelines for planning the electrical installation (page 65)</a> <a href="#">Technical data (page 167)</a>
↓	
Unpack and examine the drive. Make sure that all necessary optional modules and equipment are present and correct.	<a href="#">Mechanical installation (page 43)</a>
↓	
If the drive will be connected to another system than symmetrically grounded TN-S system: Examine if you must disconnect the EMC filter or ground-to-phase varistor.	<a href="#">IEC: Grounding system compatibility check (page 91)</a>
↓	
Install the drive on a wall.	<a href="#">Mechanical installation (page 43)</a>
↓	
Route the cables.	<a href="#">Routing the cables (page 78)</a>
↓	
Measure the insulation of the input cable and the motor and the motor cable.	<a href="#">IEC: Measuring the insulation (page 90)</a>
↓	
Connect the power cables.	<a href="#">IEC: Connecting the power cables (page 99)</a>

---

**Task****See**

↓

Connect the control cables.

[IEC: Connecting the control cables \(page 116\)](#)

↓

Check the installation.

[Installation checklist \(page 149\)](#)

↓

Commission the drive.

[ACP510-01 standard control program firmware manual \(3AXD50001148645 \[English\]\).](#)

## Terms and abbreviations

Term	Description
BCU	Type of control unit
Drive	Frequency converter for controlling AC motors
EMC	Electromagnetic compatibility
EMI	Electromagnetic interference
FEN-01	Optional TTL incremental encoder interface module
FEN-11	Optional absolute encoder interface module
FEN-21	Optional resolver interface module
FEN-31	Optional HTL incremental encoder interface module
FIO-11	Optional analog I/O extension module
FPTC-01	Optional thermistor protection module
FPTC-02	Optional ATEX-certified thermistor protection module for potentially explosive atmospheres
Frame, frame size	Physical size of the drive or power module
FSO-12, FSO-21	Optional functional safety modules
IGBT	Insulated gate bipolar transistor
Inverter unit	Inverter module(s) under control of one control unit, and related components. One inverter unit typically controls one motor.
Power module	Common term for drive module, inverter module, supply module, brake chopper module etc.
RFI	Radio-frequency interference
STO	Safe torque off (IEC/EN 61800-5-2)
Supply unit	Supply module(s) under control of one control unit, and related components.

## Related documents

Name	Code (English/ Multilingual)
<b>Drive manuals and guides</b>	
ACP510-01 drives (0.75 to 250 kW) hardware manual	3AXD50001148140
ACP510-04 drive modules hardware manual	3AXD50001148164
ACP510-01 Drive quick installation and start-up guide frames R1 to R5	3AXD50001148188
ACP510-01 Drive quick installation and start-up guide frames R6 to R9	3AXD50001148201
ACP510-04 Drive modules quick installation guide frames R10 to R11	3AXD50001148621
ACP510 standard control program firmware manual	3AXD50001148645
ACP510 drives recycling instructions and environmental information	3AXD50001148669
Drive modules cabinet design and construction instructions	<a href="#">3AUA0000107668</a>
Installation of drive module frames R6 to R9 in Rittal VX25 enclosure supplement	<a href="#">3AXD50000523191</a>
Alternate Fuses, MMPs and Circuit Breakers for ABB Drives	<a href="#">3AXD50000645015</a>
<b>Option manuals and guides</b>	
DPMP-02/03 mounting platform for control panels	<a href="#">3AUA0000136205</a>
FPBA-01 PROFIBUS DP adapter module user's manual	<a href="#">3AFE68573271</a>
FENA-21 Ethernet adapter module user's manual	<a href="#">3AUA0000093568</a>
FECA-01 EtherCAT adapter module user's manual	<a href="#">3AUA0000068940</a>
FCAN-01 CANopen adapter module user's manual	<a href="#">3AFE68615500</a>
FDNA-01 DeviceNet™ adapter module user's manual	<a href="#">3AFE68573360</a>
FSCA-01 RS-485 adapter module user's manual	<a href="#">3AUA0000109533</a>
FEPL-02 Ethernet POWERLINK adapter module user's manual	<a href="#">3AUA0000123527</a>
FOCH du/dt filters hardware manual	<a href="#">3AFE68577519</a>
ACS-AP-/I/S/W control panel	
<b>Tool and maintenance manuals and guides</b>	
Drive Composer Start-up and maintenance PC tool user's manual	<a href="#">3AUA0000094606</a>
Converter module capacitor reforming instructions	<a href="#">3BFE64059629</a>
NETA-21 remote monitoring tool user's manual	<a href="#">3AUA0000096939</a>
NETA-21 remote monitoring tool installation and start-up guide	<a href="#">3AUA0000096881</a>
CCA-01 Configuration Adapter	



# 3

## **Operation principle and hardware description**

---

### **Contents of this chapter**

This chapter briefly describes the operation principle and construction of the drive.

---

## Operation principle

The ACP510-01 is a drive for controlling asynchronous AC induction motors.

The figure below shows the simplified main circuit diagram of the drive.

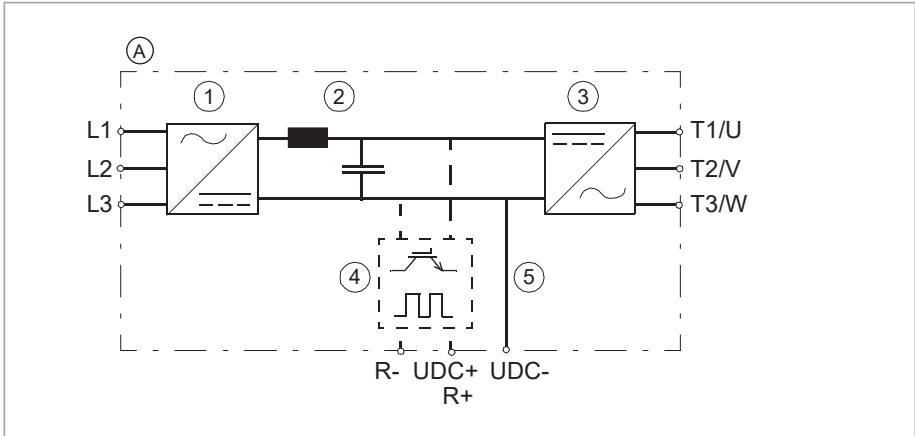

A	Drive
1	Rectifier. Converts alternating current and voltage to direct current and voltage.
2	DC link. DC circuit between rectifier and inverter.
3	Inverter. Converts direct current and voltage to alternating current and voltage.
4	Built-in brake chopper (R-, R+) in frames R1...R3. Conducts the surplus energy from the intermediate DC circuit of the drive to the brake resistor when necessary. The chopper operates when the DC link voltage exceeds a certain maximum limit. The voltage rise is typically caused by deceleration (braking) of a high inertia motor. The user obtains and installs the brake resistor when needed.
5	DC connection (UDC+, UDC-), for an external brake chopper in frames R4...R9.

## Layout

### Frames R1...R2

The layout of a frame R1 drive is presented below. The main structure of frame R2 is similar to R1.

### R1 IP20

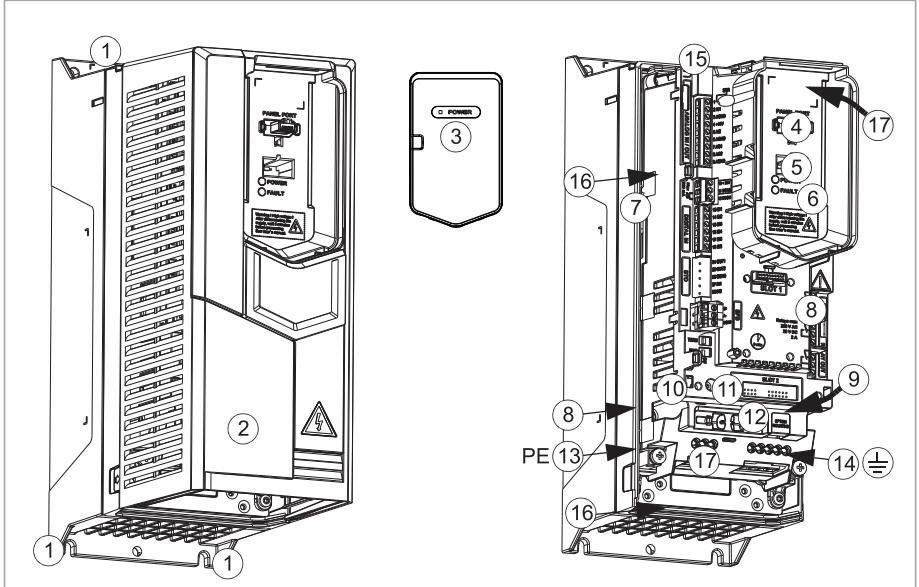

1	Mounting points (4 pieces)	9	EMC filter grounding screw (EMC (DC)). For disconnecting, see page 96 (IEC).
2	Cover	10	Place for storing the removed VAR screw
3	Control panel	11	Place for storing the removed EMC screw
4	Blank cover RDUM-01	12	Input power connection (L1, L2, L3), motor connection (T1/U, T2/V, T3/W) and brake resistor connection (R-, R+)
5	Cold configuration connection for CCA-01	13	PE connection (power line)
6	Power OK and Fault LEDs. See section LEDs (page 164).	14	Stripping length (8 mm) checker
7	I/O connections. See <a href="#">External control connection terminals, frames R1...R5 (page 36)</a> .	15	Main cooling fan
8	Varistor grounding screw (VAR). For disconnecting, see page 96 (IEC).	16	Cable tie mounts for /I/O cables
		17	Auxiliary cooling fan connector

**Frame R3...R5**

**R3 IP20**

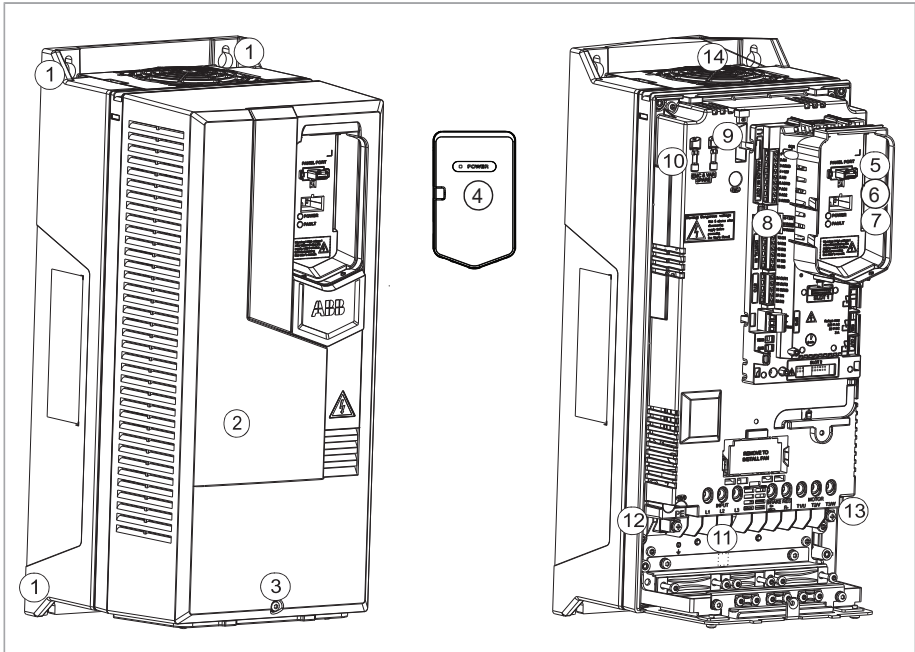

1	Mounting points (4 pieces)
2	Cover
3	Cover screw
4	Blank cover RDUM-01
5	Control panel connection
6	Cold configuration connection for CCA-01
7	Power OK and Fault LEDs. See section LEDs (page 164).
8	I/O connections. See External control connection terminals, frames R1...R5 (page 36).
9	Varistor grounding screw (VAR). For disconnecting, see page 96 (IEC).
10	EMC filter grounding screw (EMC (DC)). For disconnecting, see page 96 (IEC).

11	Input power connection (L1, L2, L3), motor connection (T1/U, T2/V, T3/W) and brake connection (R-, R+)
12	PE connection (power line)
13	Grounding connection (motor)
14	Main cooling fan

**R4 v2 IP20**

New design of frame R4 types 062A-4, 073A-4 and 089A-4 are marked as R4 v2.

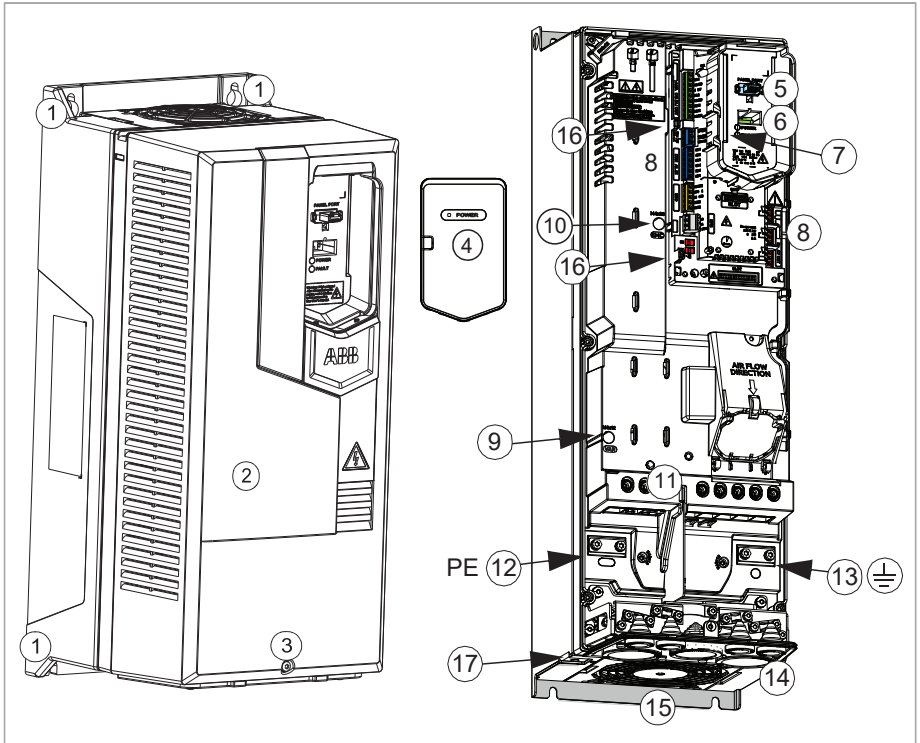

## 32 Operation principle and hardware description

1	Mounting points (4 pieces)	10	EMC filter grounding screw (EMC). For disconnecting, see page 96 (IEC).
2	Cover	11	Input power connection (L1, L2, L3), motor connection (T1/U, T2/V, T3/W) and DC connection (UDC+, UDC-)
3	Cover screw	12	PE connection (power line)
4	Blank cover RDUM-01	13	Grounding connection (motor)
5	Control panel connection	14	Cable entry
6	Cold configuration connection for CCA-01	15	Main cooling fan
7	Power OK and Fault LEDs. See section LEDs (page 164).	16	Cable tie mounts for /I/O cables
8	I/O connections. See External control connection terminals, frames R1...R5 (page 36).	17	Additional grounding connection
9	Varistor grounding screw (VAR). For disconnecting, see page 96 (IEC).		

### Frame R6...R9

The layout of a frame R6 drive is presented below. The constructions of frames R6...R9 differ to some extent.

#### R6 IP20

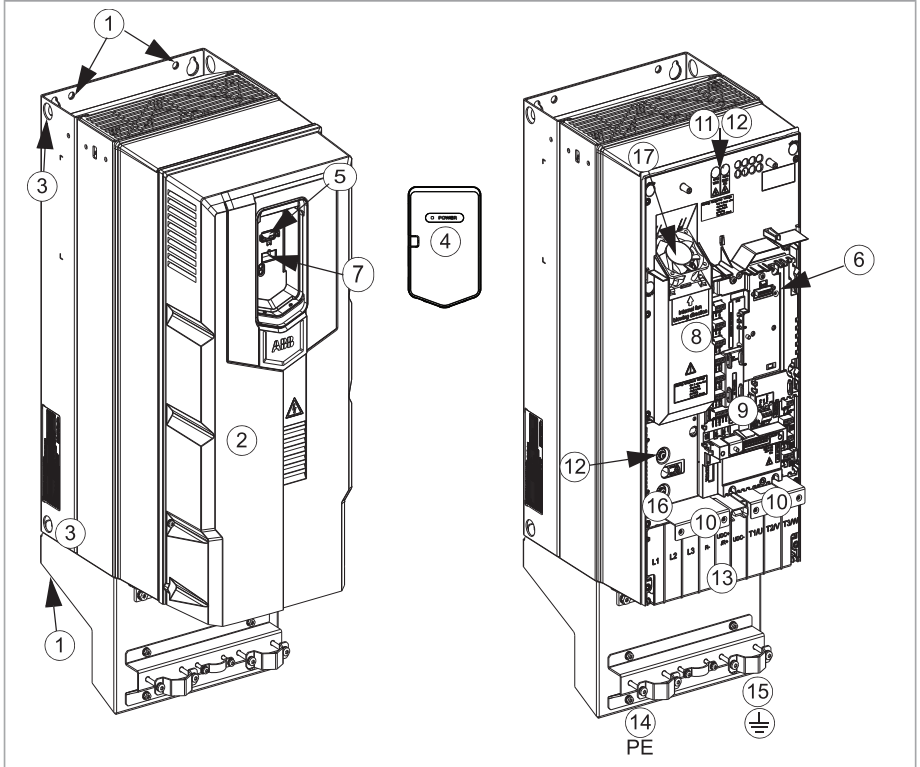

### 34 Operation principle and hardware description

1	Mounting points (4 pieces: 2 at the top, 2 at the bottom of the main part of the frame)	11	Varistor grounding screw (VAR), under the control panel platform. For disconnecting, see page 96 (IEC).
2	Cover	12	Two EMC filter grounding screws, 14a: EMC (DC) under the control panel platform and 14b: (EMC (AC) at the left, above the shroud. For disconnecting, see page 96 (IEC).
3	Lifting holes (4 pieces)	13	Shroud. Under the shroud: Input power connection (L1, L2, L3), motor connection (T1/U, T2/V, T3/W) and DC connection (UDC+, UDC-)
4	Blank cover RDUM-01	14*	PE connection (power line)
5	Control panel connection	15*	Grounding connection (motor), under the shroud (15)
6	Cold configuration connection for CCA-01	16	1 main cooling fan (R6...R8); 2 main cooling fans at the bottom (R9)
7	Power OK and Fault LEDs. See section LEDs (page 164).	17	Auxiliary cooling fan
8	I/O connections. See External control connection terminals, frames R1...R5 (page 36).		
9	Cable tie mounts for /I/O cables		
10	Clamps for I/O cable mechanical support		

\*Drive with cable box is used as an example in the figure. Cable box is optional and need to be ordered separately.

## Overview of power and control connections

The logical diagram below shows the power connections and control interfaces of the drive.

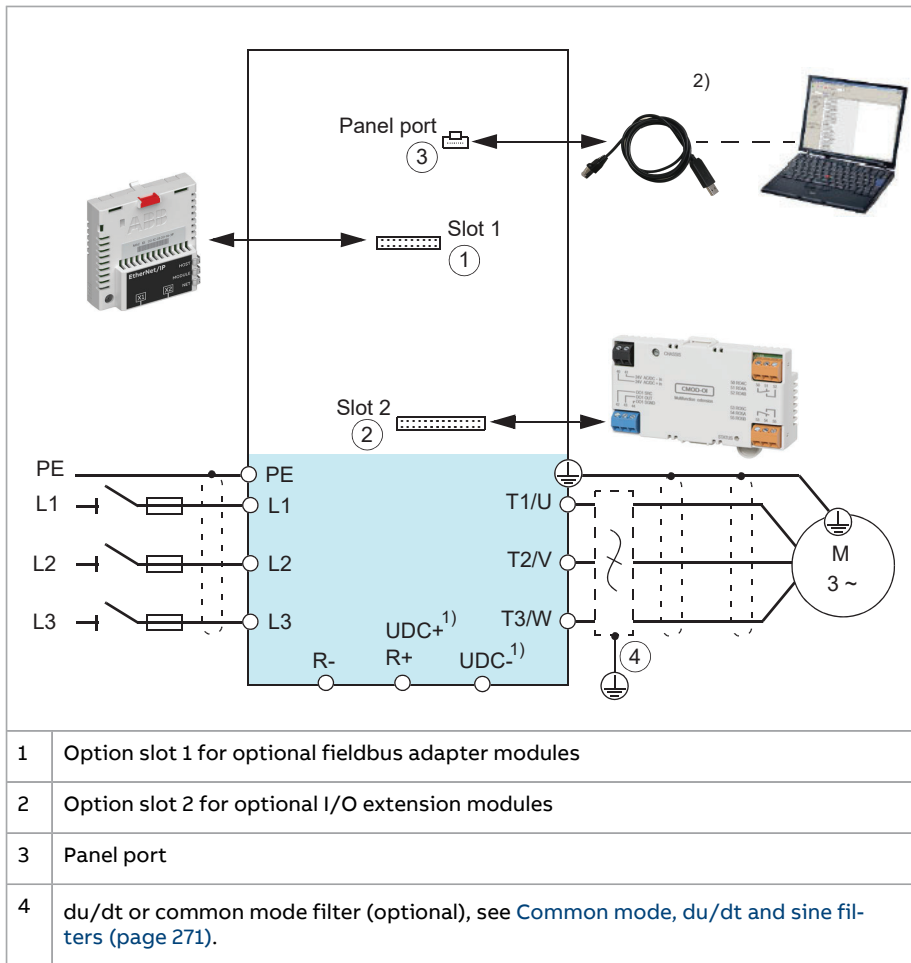

<sup>1)</sup>Not in all frame sizes

<sup>2)</sup>To connect the PC tools, a commissioning cable BCBL-01 or an assistant control panel (optional) is needed.

■ External control connection terminals, frames R1...R5

The layout of the external control connection terminals of the R1 frame is shown below. Layout of the external control connection terminals is identical in frames R1...R5 but the location of the control unit with the terminals is different in frames R3...R5.

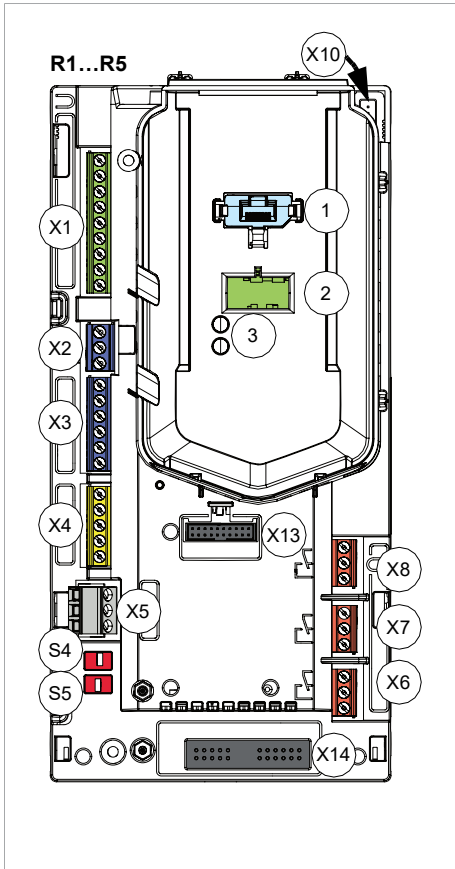

	Description
X1	Analog inputs and outputs
X2	Aux. voltage output
X3	Programmable digital inputs
X4	Safe torque off connection
X5	Embedded fieldbus
X6	Relay output 3
X7	Relay output 2
X8	Relay output 1
X10	Auxiliary fan connection
X13	Option slot 1 (fieldbus adapter modules)
X14	Option slot 2 (I/O extension modules)
S4,S5	Termination switch (S4), bias resistor switch (S5), see <a href="#">Embedded EIA-485 fieldbus connection (page 136)</a> .
1	Panel port (control panel connection)
2	Cold configuration connection. This connector is used with the CCA-01 configuration adapter.
3	Power OK and Fault LEDs. See <a href="#">section LEDs (page 164)</a> .

■ External control connection terminals, frames R6...R9

The layout of the external control connection terminals of frames R6...R9 is shown below.

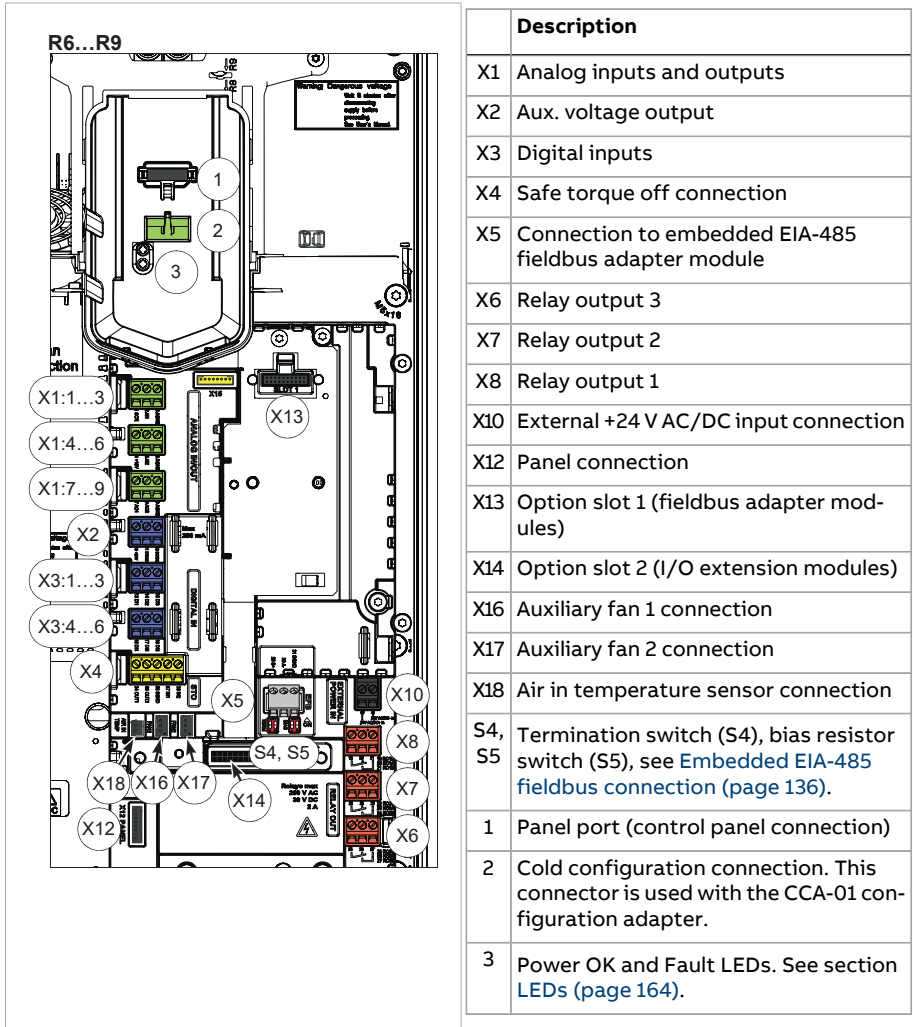

## Control Panel (optional)

To remove the control panel, press the retaining clip at the top (2) and pull the panel forward from the top edge (3).

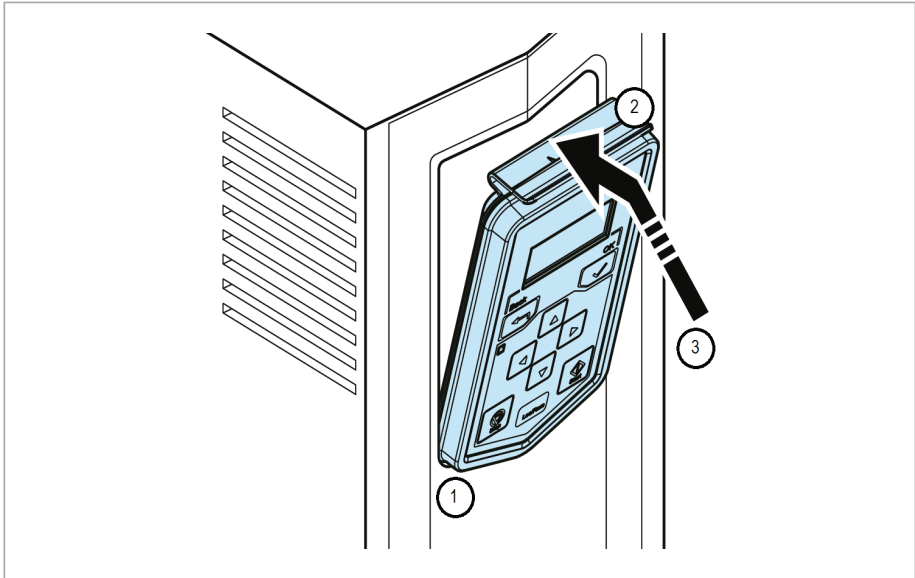

To reinstall the control panel, put the bottom of the container in position (1), press the retaining clip at the top (2) and push the control panel in at the top edge (3).

For the use of the control panel, see the firmware manual and *ACS-AP-I, -S, -W and ACH-AP-H, -W Assistant control panel user's manual* ([3AUA0000085685](#) [English]) and *ACS-BP-S basic control panel user's manual* ([3AXD50000032527](#) [English]).

### ■ Control panel door mounting kits

You can use a mounting platform to mount the control panel on the cabinet door. Mounting platforms for control panels are available as options from ABB. For more information, see

Manual	Code (English)
<i>DPMP-01 mounting platform for control panels installation guide</i>	<a href="#">3AUA0000100140</a>
<i>DPMP-02/03 mounting platform for control panels installation guide</i>	<a href="#">3AUA0000136205</a>

## Type designation label

The type designation label includes IEC ratings, appropriate markings and the type designation and serial number, which allow identification of each drive. The type designation label is located on the left side of the drive, see section [Locations of the labels on the drive \(page 40\)](#). An example label is shown below.

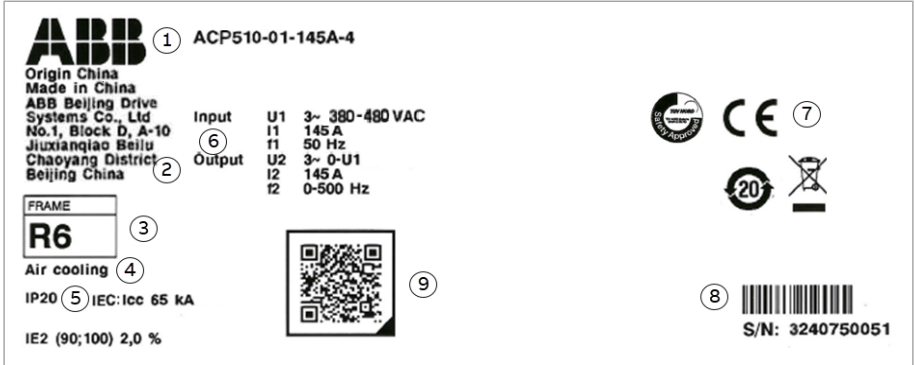

No.	Description
1	Type designation, see section <a href="#">Type designation key (page 40)</a> .
2	Name and address of the manufacturer
3	Frame (size)
4	Type of the drive, for example, with Air cooling or Liquid cooling, and so on.
5	Degree of protection
6	Nominal ratings in the supply voltage range, see <a href="#">Ratings (page 167)</a> , <a href="#">Electrical power network specification (page 186)</a> and <a href="#">Motor connection data (page 189)</a> .
7	Valid markings
8	S/N: Serial number of format MYYWWXXXXX, where M: Manufacturing plant YY: 16, 17, 18, ... for 2016, 2017, 2018, ... WW: 01, 02, 03, ... for week 1, week 2, week 3, ... XXXXX: Digits making the serial number unique
9	Link to the product data sheet

■ Locations of the labels on the drive

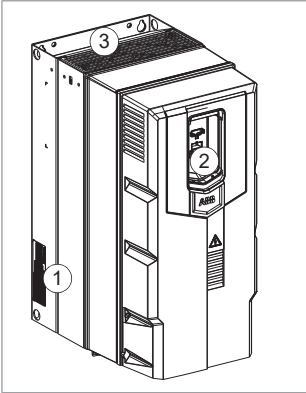

<p>1</p>	<div style="display: flex; justify-content: space-between;"> <div style="width: 45%;"> <p><b>ABB</b> Origin China Made in China ABB Beijing Drive Systems Co., Ltd No.1, Block D, A-10 Jiuxianqiao Beilu Chaoyang District Beijing China</p> <p>FRAME <b>R6</b> Air cooling IP20 IEC: Icc 65 kA IE2 (90/100) 2,0 %</p> </div> <div style="width: 45%;"> <p>ACP510-01-145A-4</p> <table border="0"> <tr> <td>Input</td> <td>U1</td> <td>3~ 380-480 VAC</td> </tr> <tr> <td></td> <td>I1</td> <td>145 A</td> </tr> <tr> <td></td> <td>f1</td> <td>50 Hz</td> </tr> <tr> <td>Output</td> <td>U2</td> <td>3~ 0-U1</td> </tr> <tr> <td></td> <td>I2</td> <td>145 A</td> </tr> <tr> <td></td> <td>f2</td> <td>0-500 Hz</td> </tr> </table> <p>QR Code</p> <p>CE, RoHS, 20, and other compliance symbols</p> <p>S/N: 3240750051</p> </div> </div>	Input	U1	3~ 380-480 VAC		I1	145 A		f1	50 Hz	Output	U2	3~ 0-U1		I2	145 A		f2	0-500 Hz
Input	U1	3~ 380-480 VAC																	
	I1	145 A																	
	f1	50 Hz																	
Output	U2	3~ 0-U1																	
	I2	145 A																	
	f2	0-500 Hz																	
<p>2</p>	<p><b>ACP510-01-145A-4</b> <b>S/N: 3240750051</b> <b>SW v2.18.4.3</b></p>																		
<p>3</p>	<table border="0"> <tr> <td>U1</td> <td>3~ 380-480 VAC</td> <td>ACP510-01-145A-4</td> </tr> <tr> <td>I2</td> <td>145A</td> <td>Barcode</td> </tr> <tr> <td>P</td> <td>75 kW</td> <td>S/N: 3240750051</td> </tr> </table>	U1	3~ 380-480 VAC	ACP510-01-145A-4	I2	145A	Barcode	P	75 kW	S/N: 3240750051									
U1	3~ 380-480 VAC	ACP510-01-145A-4																	
I2	145A	Barcode																	
P	75 kW	S/N: 3240750051																	

**Type designation key**

The type designation contains information on the specifications and configuration of the drive. You find the type designation on the type designation label attached to the drive. The first digits from the left express the basic configuration, for example, ACP510-01-12A7-4. The optional selections are given after that, separated

by plus signs, for example, +L501. The main selections are described below. Not all selections are available for all types.

Code	Description
<b>Basic codes</b>	
ACP510-01	Product series
01	When no options are selected: Wall mounted, IP20, blank cover RDUM-01,choke, EMC C2 filter (built-in EMC filter), safe torque off, braking chopper in frames R1, R2, R3, coated boards, cable entry from the bottom, cable box (optional) or the conduit plate with cable entries, quick installation and start-up guide.
<b>Size</b>	
xxxx	See the rating tables
<b>Voltage rating</b>	
4	4 = 380...480 V See the technical data for further information.

### ■ Option codes

Code	Description
J400	ACS-AP-S control panel
K451	FDNA-01 DeviceNet™ adapter module
K454	FPBA-01 PROFIBUS DP adapter module
K457	FCAN-01 CANopen adapter module
K458	FSCA-01 RS-485 (Modbus/RTU) adapter module
K462	FCNA-01 ControlNet™ adapter module
K469	FECA-01 EtherCat adapter module
K470	FEPL-02 EtherPOWERLINK adapter module
K490	FEIP-21 EtherNet/IP adapter module
K491	FMBT-21 Modbus/TCP adapter module
K492	FPNO-21 PROFINET IO adapter module

## 42 Operation principle and hardware description

<b>Code</b>	<b>Description</b>
L501	CMOD-01 External 24 V AC/DC and digital I/O extension (2×RO and 1×DO)
L512	CHDI-01 115/230 V digital input module (six digital inputs and two relay outputs)
L523	CMOD-02 External 24 V and isolated PTC interface
L525	CAIO-01 analog I/O extension module

---

## 4

# Mechanical installation

---

## Contents of this chapter

This chapter tells you how to examine the installation site, examine the delivery, and mechanically install the drive.

## Safety

---

**WARNING!**

Frames R5...R9 Lift the drive with a lifting device. Use the lifting eyes of the drive. Do not tilt the drive. **The drive is heavy and its center of gravity is high. An overturning drive can cause physical injury.**

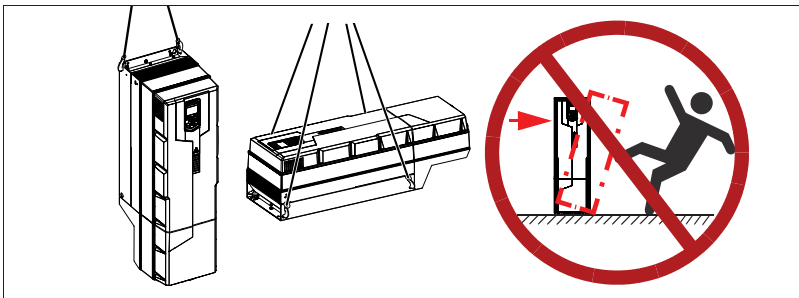

---

## Examining the installation site

Make sure that:

---

## 44 Mechanical installation

- The installation site is sufficiently ventilated or cooled to remove heat from the drive. See the technical data.
- The ambient conditions of the drive meet the specifications. See the technical data.
- The material behind, above and below the drive is non-flammable.
- The installation surface is as close to vertical as possible and strong enough to support the drive.
- There is sufficient free space around the drive for cooling, maintenance, and operation. See the free space specifications for the drive.
- Make sure that there are no sources of strong magnetic fields such as high-current single-core conductors or contactor coils near the drive. A strong magnetic field can cause interference or inaccuracy in the operation of the drive.

### Installation alternatives

The drive must be installed on the wall or an enclosure. There are three alternative ways to install it:

- Vertical

**Note:** Do not install the drive upside down.

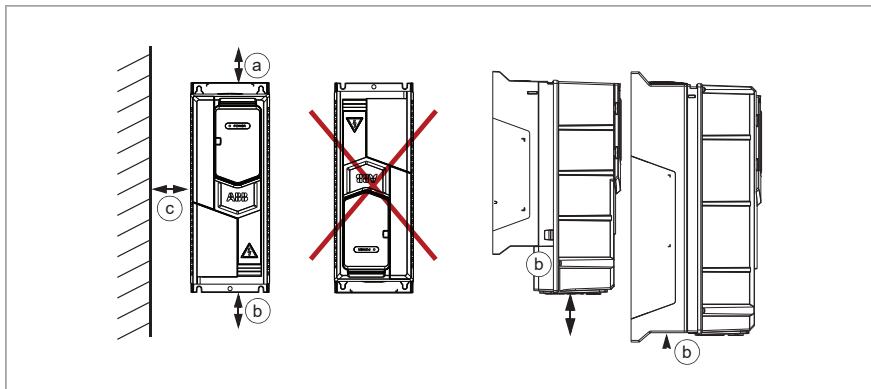

Frame size	Vertical installation - Free space		
	IP20		
	Above (a) <sup>1)</sup>	Below (b) <sup>2)</sup>	Beside (c) <sup>3)</sup>
	mm	mm	mm
R1	65	86	150
R2	65	86	150

<b>R3</b>	65	53	150
<b>R4</b>	53	200	150
<b>R5</b>	75	200	150
<b>R6</b>	155	300	150
<b>R7</b>	155	300	150
<b>R8</b>	155	300	150
<b>R9</b>	200	300	150

<sup>1)</sup> Free space above is measured from the frame.

**Note:** The height of the hood for frames R4 and R9 exceeds the requirement of free space above for these frames

Frame size	Hood height (mm)
R4	72
R9	230

<sup>2)</sup> Free space below is always measured from the drive frame, not from the cable box (optional).

<sup>3)</sup> Free space between the drive and other objects, e.g. wall.

**Note:** The recommended free space above and below the drive is for installations where the drive is mounted on a wall indoors. For ABB cabinet-built drives, which are thermally tested and approved for a specified temperature range, free space could vary from this recommendation.

- Vertical side by side or between walls



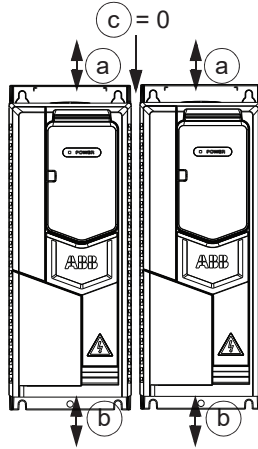

Frame size	Vertical installation side by side - Free space, IP20		
	Above (a) <sup>1)</sup>	Below (b) <sup>2)</sup>	Between (c) <sup>3)</sup>
	mm	mm	mm
R1	200	200	0
R2	200	200	0
R3	200	200	0
R4	200	200	0
R5	200	200	0
R6	200	300	0
R7	200	300	0
R8	200	300	0
R9	200	300	0

1) Free space above is measured from the frame.

**Note:** The height of the hood for frame R9 exceeds the requirement of free space above for these frames

Frame size	Hood height (mm)
R9	230

2) Free space below is always measured from the drive frame, not from the cable box (optional).



3) Free space between the drives.

**Note:** The recommended free space above and below the drive is for installations where the drive is mounted on a wall indoors. For ABB cabinet-built drives, which are thermally tested and approved for a specified temperature range, free space could vary from this recommendation.

**Note:** IP20 frames R1...R2: The cover fastening clips can be removed to make the front cover opening easier.

- Horizontal, IP20, R1...R5 only

**Note 1:** You can install IP20 drives horizontally.

**Note 2:** In the horizontal mounting, the drive is not protected from dripping water.

**Note 3:** The vibration specification in [Ambient conditions \(page 194\)](#) may not be fulfilled.

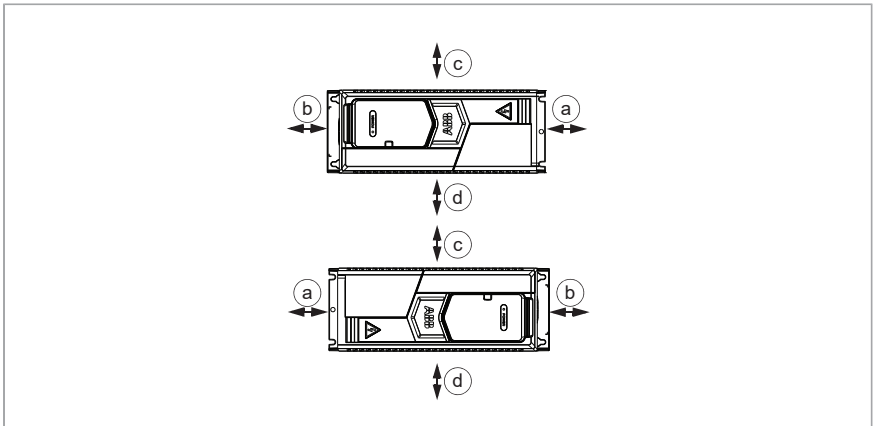

Frame size	Horizontal installation - Free space			
	IP20			
	Above (a)	Below (b) <sup>1)</sup>	Side up (c)	Side down (d)
	mm	mm	mm	mm
<b>R1</b>	150	86	30	200
<b>R2</b>	150	86	30	200
<b>R3</b>	200	53	30	200
<b>R4</b>	30	200	30	200
<b>R5</b>	30	200	30	200

<sup>1)</sup> Free space below is always measured from the drive frame, not from the cable box (optional).

## 48 Mechanical installation

Make sure that the installation site complies with the requirements below:

- The installation site is sufficiently ventilated or cooled to remove the heat away from the drive. See [Losses, cooling data and noise \(page 181\)](#).
- The operation conditions of the drive meet the specifications given in [Ambient conditions \(page 194\)](#).
- The wall is as close to vertical as possible, of non-flammable material and strong enough to carry the weight of the drive, see [Dimensions, weights and free space requirements \(page 180\)](#).
- The floor/material below the installation is non-flammable.
- There is enough free space above and below the drive to enable cooling air flow, service and maintenance. See the required free space tables for each of the different mounting alignments on page [43](#) (or page [180](#)).

### Necessary tools

To move a heavy drive, you need a crane, forklift or pallet truck (examine the load capacity).

To lift a heavy drive, you need a hoist.

To install the drive mechanically, you need these tools:

- drill with suitable bits
- screwdriver set (Torx, Phillips, flat and/or Pozidriv, as appropriate)
- torque wrench
- socket set, Hex key set (metric)
- tape measure, if you will not be using the provided mounting template.

### Moving the drive

Frames R5...R9: Move the transport package by pallet truck to the installation site.



## Unpacking and examining delivery, frames R1 and R2

The figure below shows the layout of the transport package. Examine that all items are present and there are no signs of damage. Read the data on the type designation label of the drive to make sure that the drive is of the correct type. See section [Type designation label](#) (page 39).

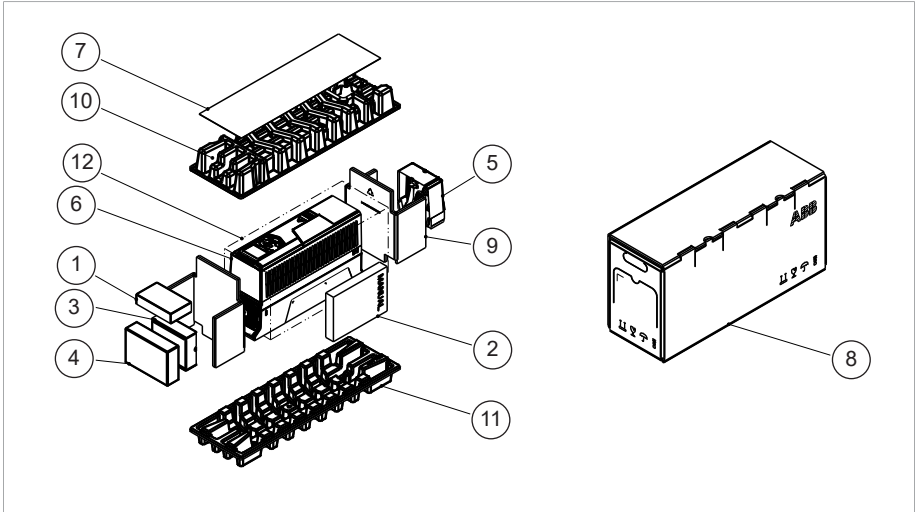

1	Control panel selected in the order.	5	Cable box (optional)
2	Quick installation and start-up guide (always), and hardware and firmware manuals (if ordered separately); Multilingual residual voltage warning stickers	6	Drive
3	I/O option box	7	Mounting template
4	Fieldbus option box	8	Cardboard box
<p><b>Note:</b> Possible options in separate packages, if they have been ordered with a plus code, such as for example +K490 (FEIP-21 Two-port EtherNet/IP adapter module) in the fieldbus option box.</p>		9	End support (2 pcs)
		10	Top cushion
		11	Bottom cushion
		12	Plastic bag



## 50 Mechanical installation

To unpack:

- Open the cardboard box (8)
- Remove the mounting template (7) and top cushion (10)
- Remove the control panel, option boxes and cable box (1,3,4,5; cable box is optional).
- Remove the end supports (9)
- Remove the plastic bag (12)
- Lift the drive (6).



**WARNING!**

R1...R2, IP20: Do not lift the drive by holding it from the cover. The drive can fall and become damaged or damage the surroundings.

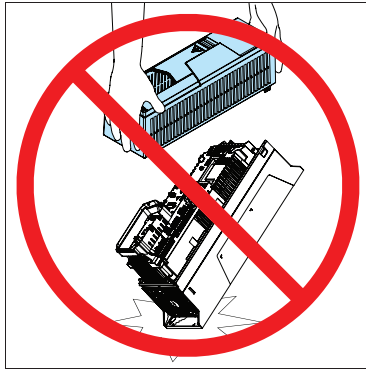
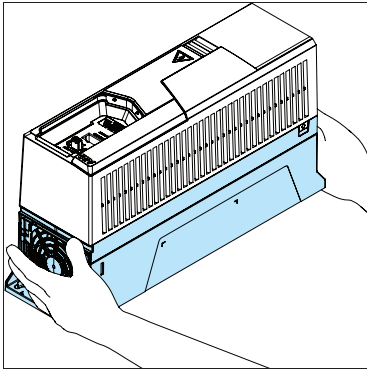

Recycle the package material according to local regulations.

## Unpacking and examining delivery, frame R3

The figure below shows the layout of the transport package. Examine that all items are present and there are no signs of damage. Read the data on the type designation label of the drive to make sure that the drive is of the correct type. See section [Type designation label](#) (page 39).

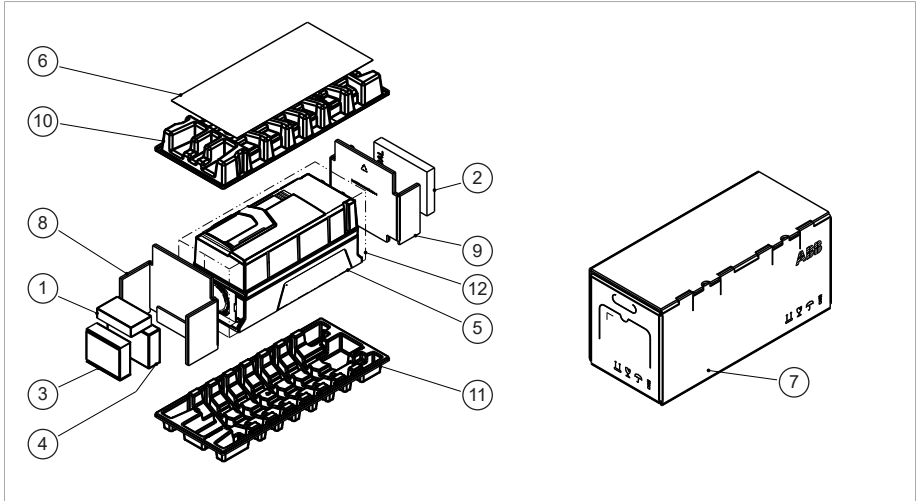

1	Control panel selected in the order.	5	Drive
2	Quick installation and start-up guide (always), and hardware and firmware manuals (if ordered separately); Multilingual residual voltage warning stickers	6	Mounting template
3	I/O option box	7	Cardboard box
4	Fieldbus option box	8	Option support
		9	End support
		10	Top cushion
		11	Bottom cushion
		12	Plastic bag

To unpack:

- Open the cardboard box (7)
- Remove the mounting template (6) and top cushion (10)
- Remove the control panel and option boxes (1,3,4)
- Remove the end supports (9)
- Remove the plastic bag (12)



## 52 Mechanical installation

- Lift the drive (2).

Recycle the package material according to local regulations.



## Unpacking and examining delivery, frames R4

The figure below shows the layout of the transport package. Examine that all items are present and there are no signs of damage. Read the data on the type designation label of the drive to make sure that the drive is of the correct type. See section [Type designation label](#) (page 39).

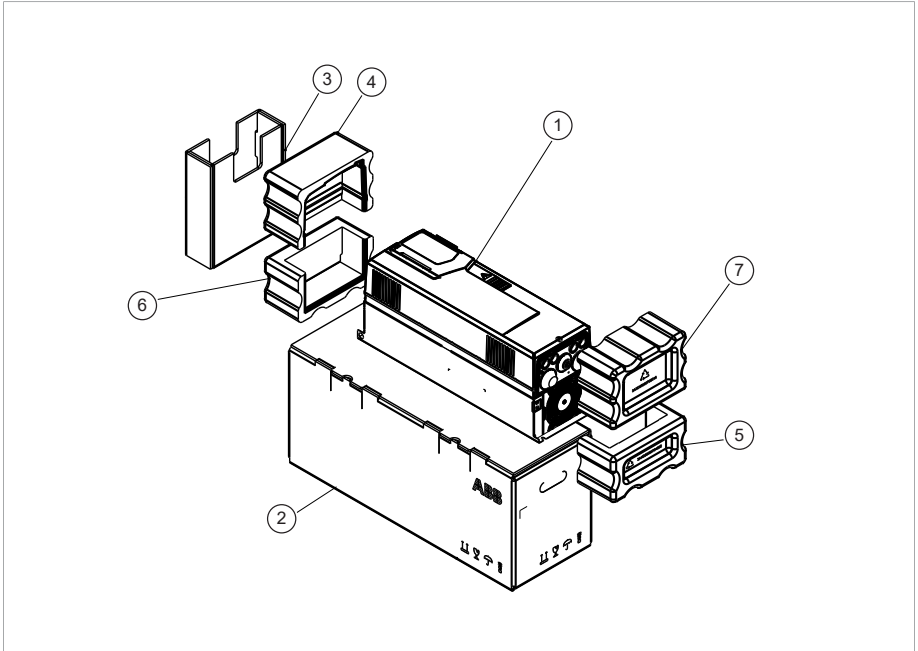

1	Drive	<ul style="list-style-type: none"> <li>Possible options in separate packages, if they have been ordered with a plus code, such as for example +K490 (FEIP-21 Two-port Ethernet/IP adapter module) in the option box</li> </ul>
2	Option tray	
3	In the option tray: <ul style="list-style-type: none"> <li>Quick installation and start-up guide (always), and hardware and firmware manuals (if ordered separately)</li> <li>Multilingual residual voltage warning stickers;</li> <li>Control panel selected in the order (in a separate package) in the option box</li> </ul>	
4	Top cushion	
5	Bottom cushion	
6	Bottom cushion	
7	Top cushion	

To unpack:

- Open box (2)
- Remove option support (3)

- Remove top cushions (4,7)
- Lift the drive (1) and remove bottom cushions (5,6).

Recycle the package material according to local regulations.

## Unpacking and examining delivery, frame R5

The figure below shows the layout of the transport package. Examine that all items are present and there are no signs of damage. Read the data on the type designation label of the drive to make sure that the drive is of the correct type. See section [Type designation label \(page 39\)](#).

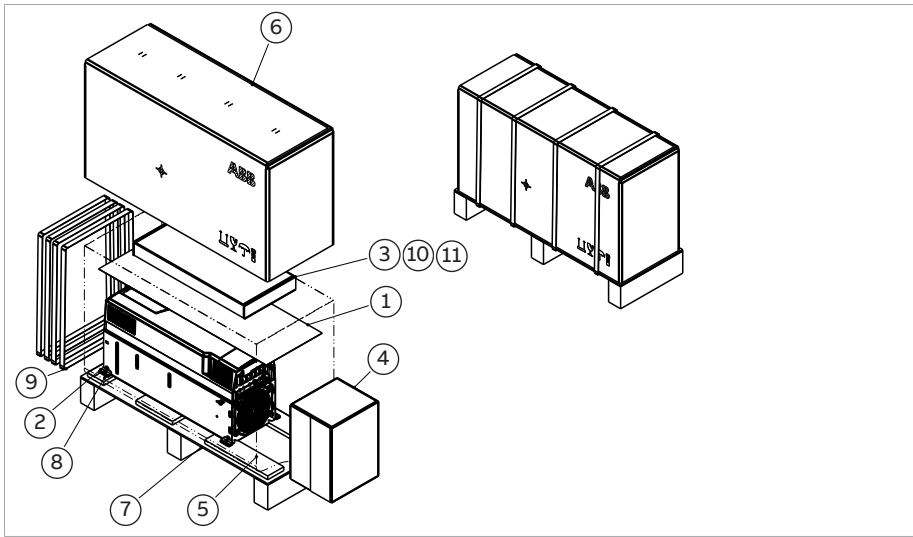

1	Cable box package (optional).	6	Cover protecting film
2	Drive	7	Straps
3	In the option box <ul style="list-style-type: none"> <li>• Quick installation and start-up guide (always), and hardware and firmware manuals (if ordered separately)</li> <li>• Multilingual residual voltage warning stickers</li> </ul>	8	Pallet
4	Cardboard box. Mounting template in the cardboard box.	9	Control panel selected in the order (in a separate package) in the option box
5	Stopper	10	Possible options in separate packages, if they have been ordered with a plus code, such as for example +K490 (FEIP-21 Two-port EtherNet/IP adapter module) in the option box.

To unpack:

- Cut the straps (7).
- Remove the cardboard box (4) and option box (3).
- Remove the cover protecting film (6).
- Lift the drive (2).



## Unpacking and examining delivery, frames R6...R9

The figure below shows the layout of the transport package. Examine that all items are present and there are no signs of damage. Read the data on the type designation label of the drive to make sure that the drive is of the correct type. See section [Type designation label](#) (page 39).

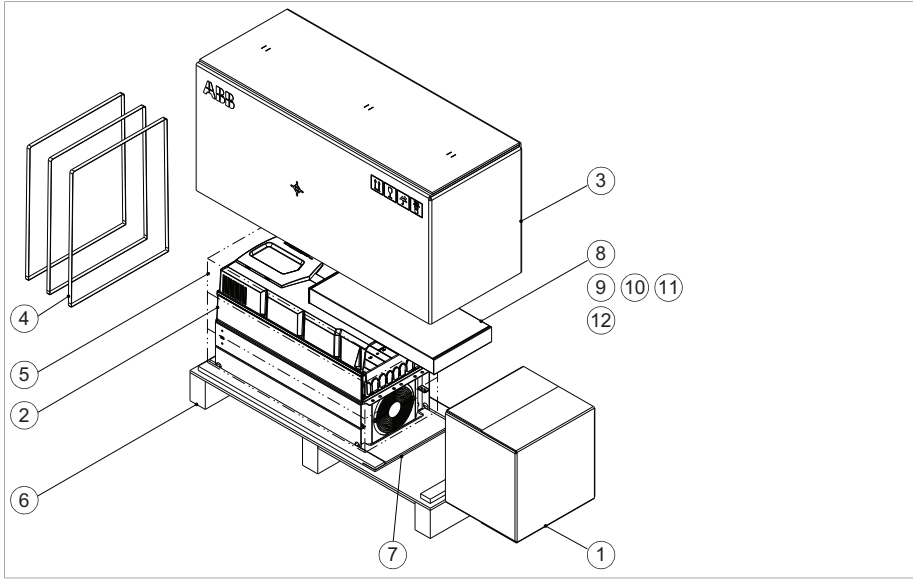

1	Cable box (optional). Power and control cable grounding shelves in a plastic bag, assembly drawing.	10	Control panel selected in the order (in a separate package) in the option tray
2	Drive with factory installed options	11	Possible options in separate packages, if they have been ordered with a plus code, such as for example +K490 (FEIP-21 Two-port EtherNet/IP adapter module) in the option box.
3	Cardboard box	12	Mounting template on top of the option tray
4	Straps		
5	VCI bag for protecting against corrosion		
6	Pallet		
7	Stopper		
8	Option tray		
9	In the option tray <ul style="list-style-type: none"> <li>• Quick installation and start-up guide (always), and hardware and firmware manuals (if ordered separately)</li> <li>• Multilingual residual voltage warning stickers</li> </ul>		

To unpack:

- Cut the straps (4).
- Remove the cardboard box (3) and option tray (8).
- Remove the VCI bag (5).
- Attach lifting hooks to the lifting eyes of the drive (see the figure in section [Safety \(page 43\)](#)).
- Lift the drive with a hoist.

Recycle the package material according to local regulations.



## Installing the drive

### ■ Installing the drive vertically, frames R1...R4

The figures show frame R3 as an example.

Select fasteners and their application to meet local requirements appropriate to wall surface materials, drive weight and application.

1. Mark the hole locations using the mounting template included in the package. Do not leave the mounting template under the drive. The drive dimensions and hole locations are also shown in the drawings in chapter [Dimension drawings \(page 201\)](#).
2. Drill the mounting holes.
3. Insert anchors or plugs into the holes and start the bolts into the anchors or plugs.

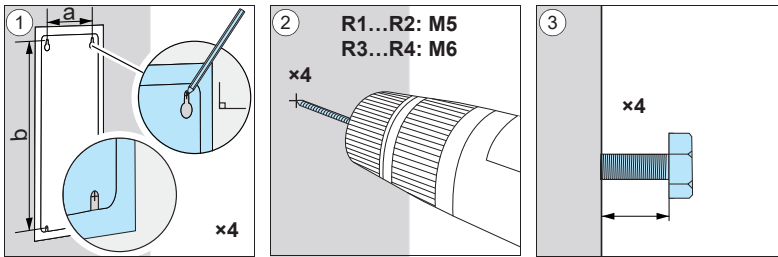

	<b>R1</b>	<b>R2</b>	<b>R3</b>	<b>R4</b>	<b>R4 v2</b>
	<b>mm</b>	<b>mm</b>	<b>mm</b>	<b>mm</b>	<b>mm</b>
<b>a</b>	98	98	160	160	160
<b>b</b>	317	417	473	619	619
<b>Weight IP20</b>	<b>kg</b>	<b>kg</b>	<b>kg</b>	<b>kg</b>	<b>kg</b>
	4	6	11.3	18.5	21.5

4. Position the drive onto the lower bolts (4a) on the wall to support the weight of the drive. Rotate drive to the wall and place drive over the upper bolts (4b).

**WARNING!**

R1...R4, IP20: Do not lift the drive by holding it from the cover. The drive can fall and become damaged or damage the surroundings.

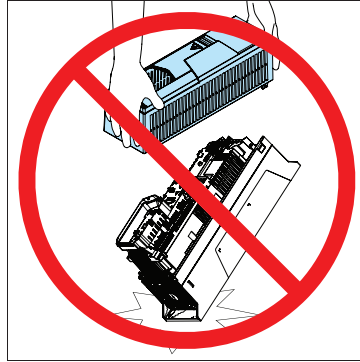
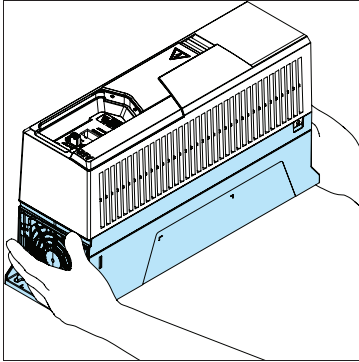

5. Tighten the bolts in the wall securely.

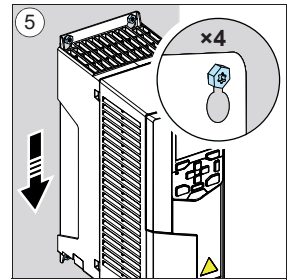
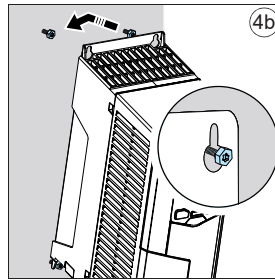
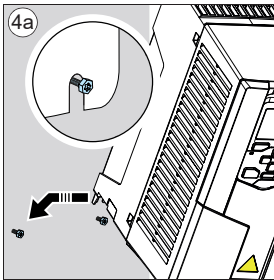

■ **Installing the drive vertically, frame R5**

Select fasteners and their application to meet local requirements appropriate to wall surface materials, drive weight and application.

1. Mark the hole locations using the mounting template included in the package. Do not leave the mounting template under the drive. The drive dimensions and hole locations are also shown in the drawings in chapter [Dimension drawings \(page 201\)](#).
2. Drill the mounting holes.
3. Insert fixing anchors or plugs into the holes. Start the two upper bolts and the two lowest bolts into the anchors or plugs.

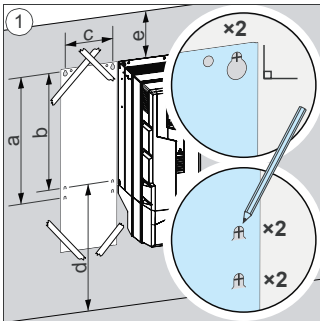

	<b>R5 IP20</b>
	<b>mm</b>
<b>a</b>	612
<b>b</b>	581
<b>c</b>	160
<b>d &gt;</b>	200
<b>e &gt;</b>	100
	<b>kg</b>
	26.5

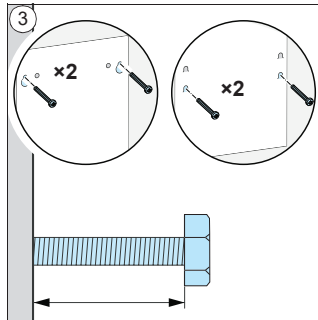
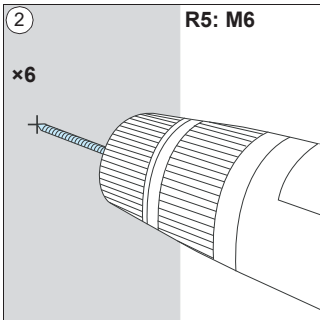

4. Remove the front cover: Remove the fastening screws with a T20 Torx screwdriver and lift the cover from the bottom upwards and then to the top side.
5. Put the tabs at the top of the front cover in their counterparts on the housing and then press at the bottom and tighten the retaining screws.
6. Position the drive onto the lower bolts (9a) on the wall to support the weight of the drive. Rotate drive to the wall and place drive over the upper bolts (9b). Lift the drive with another person or with a lifting device as it is heavy. Tighten the bolts in the wall securely (9c).
7. Tighten the two remaining bolts securely.

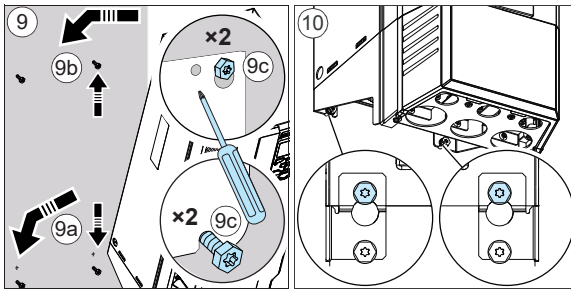

### ■ Installing the drive vertically, frames R6...R9

Select fasteners and their application to meet local requirements appropriate to wall surface materials, drive weight and application.

1. Mark the hole locations for the six mounting holes using the mounting template included in the package. Do not leave the mounting template under the drive. The drive dimensions and hole locations are also shown in the drawings in chapter [Dimension drawings \(page 201\)](#).

**Note:** You can use only two bolts instead of four to attach the lower part of the drive.



## 62 Mechanical installation

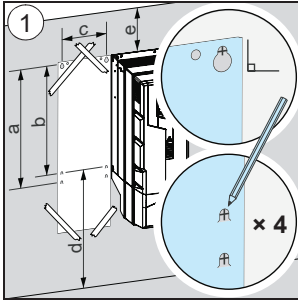

	<b>R6</b>	<b>R7</b>	<b>R8</b>	<b>R9</b>
	<b>mm</b>	<b>mm</b>	<b>mm</b>	<b>mm</b>
<b>a</b>	571	623	701	718
<b>b</b>	531	583	658	658
<b>c</b>	213	245	263	345
<b>d</b>	300	300	300	300
<b>e</b>	155	155	155	200
<b>IP20</b>	<b>kg</b>	<b>kg</b>	<b>kg</b>	<b>kg</b>
	42.6	49.6	62.8	84.4

2. Drill the mounting holes.
3. Insert fixing anchors or plugs into the holes and start the bolts into the anchors or plugs.
4. Position the drive onto the bolts on the wall. Lift the drive with a lifting device as it is heavy.
5. Tighten the top two bolts in the wall securely.

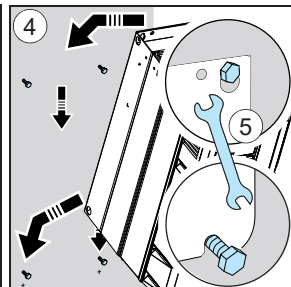
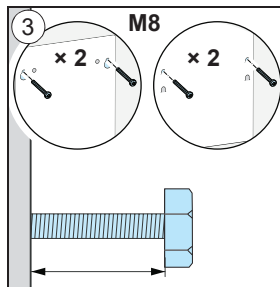
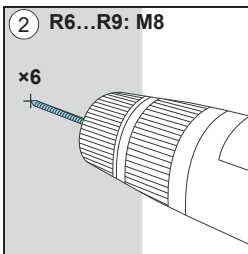

6. Remove the front cover: Remove the fastening screws (a) with a T20 Torx screwdriver, move the cover to the top side (b) and then up (c).

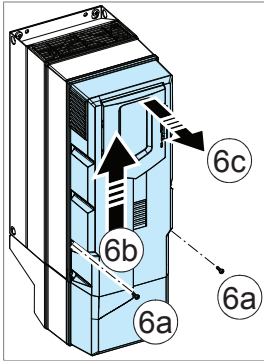

### ■ Installing the drive vertically side by side

Install the drive following the steps in the appropriate section [Installing the drive vertically, frames R1...R4 \(page 58\)](#), [Installing the drive vertically, frame R5 \(page 60\)](#) or [Installing the drive vertically, frames R6...R9 \(page 61\)](#).

### ■ Installing the drive horizontally, frames R1...R5

Install the drive following the steps in the appropriate section [Installing the drive vertically, frames R1...R4 \(page 58\)](#) or [Installing the drive vertically, frame R5 \(page 60\)](#). The drive can be installed either the left or right side up.





# 5

## Guidelines for planning the electrical installation

---

### Contents of this chapter

This chapter contains guidelines for planning the electrical installation of the drive.

### Limitation of liability

The installation must always be designed and made according to applicable local laws and regulations. ABB does not assume any liability whatsoever for any installation which breaches the local laws and/or other regulations. Furthermore, if the recommendations given by ABB are not followed, the drive may experience problems that the warranty does not cover.

### Selecting the main supply disconnecting device

You must equip the drive with a main supply disconnecting device which meets the local safety regulations. You must be able to lock the disconnecting device to the open position for installation and maintenance work.



### ■ European Union

To meet the European Union Directives, according to standard EN 60204-1, *Safety of Machinery*, the disconnecting device must be one of the following types:

- switch-disconnector of utilization category AC-23B (IEC 60947-3)
- disconnector that has an auxiliary contact that in all cases causes switching devices to break the load circuit before the opening of the main contacts of the disconnector (EN 60947-3)
- circuit-breaker suitable for isolation in accordance with IEC 60947-2.

### ■ Other regions

The disconnecting device must conform to the applicable local safety regulations.

## Examining the compatibility of the motor and drive

Use asynchronous AC induction motors with the drive.

Select the motor size and drive type from the rating table on basis of the AC line voltage and motor load. You can find the rating table in the appropriate hardware manual. You can also use the DriveSize PC tool.

Make sure that the motor can be used with an AC drive. See [Requirements table \(page 67\)](#). For basics of protecting the motor insulation and bearings in drive systems, see [Protecting the motor insulation and bearings \(page 66\)](#).

#### Note:

- Consult the motor manufacturer before using a motor whose nominal voltage differs from the AC line voltage connected to the drive input.
- The voltage peaks at the motor terminals are relative to the supply voltage of the drive, not the drive output voltage.

### ■ Protecting the motor insulation and bearings

The drive employs modern IGBT inverter technology. Regardless of frequency, the drive output comprises pulses of approximately the drive DC bus voltage with a very short rise time. The pulse voltage can almost double at the motor terminals, depending on the attenuation and reflection properties of the motor cable and the terminals. This can cause additional stress on the motor and motor cable insulation.

Modern variable speed drives with their fast rising voltage pulses and high switching frequencies can generate current pulses that flow through the motor bearings. This can gradually erode the bearing races and rolling elements.



$du/dt$  filters protect motor insulation system and reduce bearing currents. Common mode filters mainly reduce bearing currents. Insulated N-end (non-drive end) bearings protect the motor bearings.

■ **Requirements table**

These tables show how to select the motor insulation system and when a drive  $du/dt$  and common mode filters and insulated N-end (non-drive end) motor bearings are required. Ignoring the requirements or improper installation may shorten motor life or damage the motor bearings and voids the warranty.

This table shows the requirements when an ABB motor is in use.

Motor type	Nominal AC line voltage	Requirement for			
		Motor insulation system	ABB $du/dt$ and common mode filters, insulated N-end motor bearings		
			$P_n < 100$ kW and frame size < IEC 315	$100$ kW $\leq P_n < 350$ kW or IEC 315 $\leq$ frame size < IEC 400	$P_n \geq 350$ kW or frame size $\geq$ IEC 400
			$P_n < 134$ hp	$134$ hp $\leq P_n < 469$ hp	$P_n \geq 469$ hp or frame size > NEMA 580
Random-wound M2_, M3_ and M4_	$U_n \leq 500$ V	Standard	-	+ N	+ N + CMF
Form-wound HX_ and AM_	$380$ V < $U_n \leq 690$ V	Standard	n.a.	+ N + CMF	$P_n < 500$ kW: + N + CMF
					$P_n \geq 500$ kW: + N + $du/dt$ + CMF
Old <sup>1)</sup> form-wound HX_ and modular	$380$ V < $U_n \leq 690$ V	Check with the motor manufacturer.	+ N + $du/dt$ with voltages over 500 V + CMF		
Random-wound HX_ and AM_ <sup>2)</sup>	$0$ V < $U_n \leq 500$ V	Enamelled wire with fiber glass taping	+ N + CMF		
			+ N + $du/dt$ + CMF		

1) manufactured before 1.1.1998

2) For motors manufactured before 1.1.1998, check for additional instructions with the motor manufacturer.



This table shows the requirements when a non-ABB motor is in use.

Motor type	Nominal AC line voltage	Requirement for			
		Motor insulation system	ABB du/dt and common mode filters, insulated N-end motor bearings		
			$P_n < 100 \text{ kW}$ and frame size < IEC 315	$100 \text{ kW} \leq P_n < 350 \text{ kW}$ or IEC 315 ≤ frame size < IEC 400	$P_n \geq 350 \text{ kW}$ or frame size ≥ IEC 400
$P_n < 134 \text{ hp}$	$134 \text{ hp} \leq P_n < 469 \text{ hp}$	$P_n \geq 469 \text{ hp}$			
Random-wound and form-wound	$U_n \leq 420 \text{ V}$	Standard: $\hat{U}_{LL} = 1300 \text{ V}$	-	+ N or CMF	+ N + CMF
	$420 \text{ V} < U_n \leq 500 \text{ V}$	Standard: $\hat{U}_{LL} = 1300 \text{ V}$	+ du/dt	+ du/dt + (N or CMF)	+ N + du/dt + CMF
		or Reinforced: $\hat{U}_{LL} = 1600 \text{ V}$ , 0.2 micro-second rise time	-	+ N or CMF	+ N + CMF

The abbreviations used in the tables are defined below.



Abbr.	Definition
$U_n$	Nominal AC line voltage
$\hat{U}_{LL}$	Peak line-to-line voltage at motor terminals which the motor insulation must withstand
$P_n$	Motor nominal power
du/dt	du/dt filter at the output of the drive
CMF	Common mode filter of the drive
N	N-end bearing: insulated motor non-drive end bearing
n.a.	Motors of this power range are not available as standard units. Consult the motor manufacturer.

## Availability of $du/dt$ filter and common mode filter by drive type

TO BE ADDED
-------------

### Additional requirements for explosion-safe (EX) motors

If you will use an explosion-safe (EX) motor, follow the rules in the requirements table above. In addition, consult the motor manufacturer for any further requirements.

### Additional requirements for ABB motors of types other than M2\_, M3\_, M4\_, HX\_ and AM\_

Use the selection criteria given for non-ABB motors.

### Additional requirements for braking applications

When the motor brakes the machinery, the intermediate circuit DC voltage of the drive increases, the effect being similar to increasing the motor supply voltage by up to 20 percent. Consider this voltage increase when specifying the motor insulation requirements if the motor will be braking a large part of its operation time.

Example: Motor insulation requirement for a 400 V AC line voltage application must be selected as if the drive were supplied with 480 V.

### Additional requirements for ABB high-output and IP23 motors

The rated output power of high output motors is higher than what is stated for the particular frame size in EN 50347 (2001).

This table shows the requirements for protecting the motor insulation and bearings in drive systems for ABB random-wound motor series (for example, M3AA, M3AP and M3BP).

Nominal AC supply voltage	Requirement for			
	Motor insulation system	ABB $du/dt$ and common mode filters, insulated N-end motor bearings		
		$P_n < 100 \text{ kW}$	$100 \text{ kW} \leq P_n < 200 \text{ kW}$	$P_n \geq 200 \text{ kW}$
		$P_n < 140 \text{ hp}$	$140 \text{ hp} \leq P_n < 268 \text{ hp}$	$P_n \geq 268 \text{ hp}$
$U_n \leq 500 \text{ V}$	Standard	-	+ N	+ N + CMF

### Additional requirements for non-ABB high-output and IP23 motors

The rated output power of high output motors is higher than what is stated for the particular frame size in EN 50347 (2001).

## 70 Guidelines for planning the electrical installation

If you plan to use a non-ABB high-output motor or an IP23 motor, consider these additional requirements for protecting the motor insulation and bearings in drive systems:

- If motor power is below 350 kW: Equip the drive and/or motor with the filters and/or bearings according to the table below.

Nominal AC supply voltage	Requirement for		
	Motor insulation system	ABB $du/dt$ and common mode filters, insulated N-end motor bearings	
		$P_n < 100$ kW or frame size < IEC 315	100 kW < $P_n < 350$ kW or IEC 315 < frame size < IEC 400
		$P_n < 134$ hp	134 hp < $P_n < 469$ hp
$U_n \leq 420$ V	Standard: $\hat{U}_{LL} = 1300$ V	+ N or CMF	+ N or CMF
$420$ V < $U_n < 500$ V	Standard: $\hat{U}_{LL} = 1300$ V	+ $du/dt$ + (N or CMF)	+ N + $du/dt$ + CMF
	or Reinforced: $\hat{U}_{LL} = 1600$ V, 0.2 micro-second rise time	+ N or CMF	+ N or CMF

### Additional data for calculating the rise time and the peak line-to-line voltage

The diagrams below show the relative peak line-to-line voltage and rate of change of voltage as a function of the motor cable length. If you need to calculate the actual peak voltage and voltage rise time considering the actual cable length, proceed as follows:

- Peak line-to line voltage: Read the relative  $\hat{U}_{LL}/U_n$  value from the diagram below and multiply it by the nominal supply voltage ( $U_n$ ).
- Voltage rise time: Read the relative values  $\hat{U}_{LL}/U_n$  and  $(du/dt)/U_n$  from the diagram below. Multiply the values by the nominal supply voltage ( $U_n$ ) and substitute into equation  $t = 0.8 \cdot \hat{U}_{LL}/(du/dt)$ .

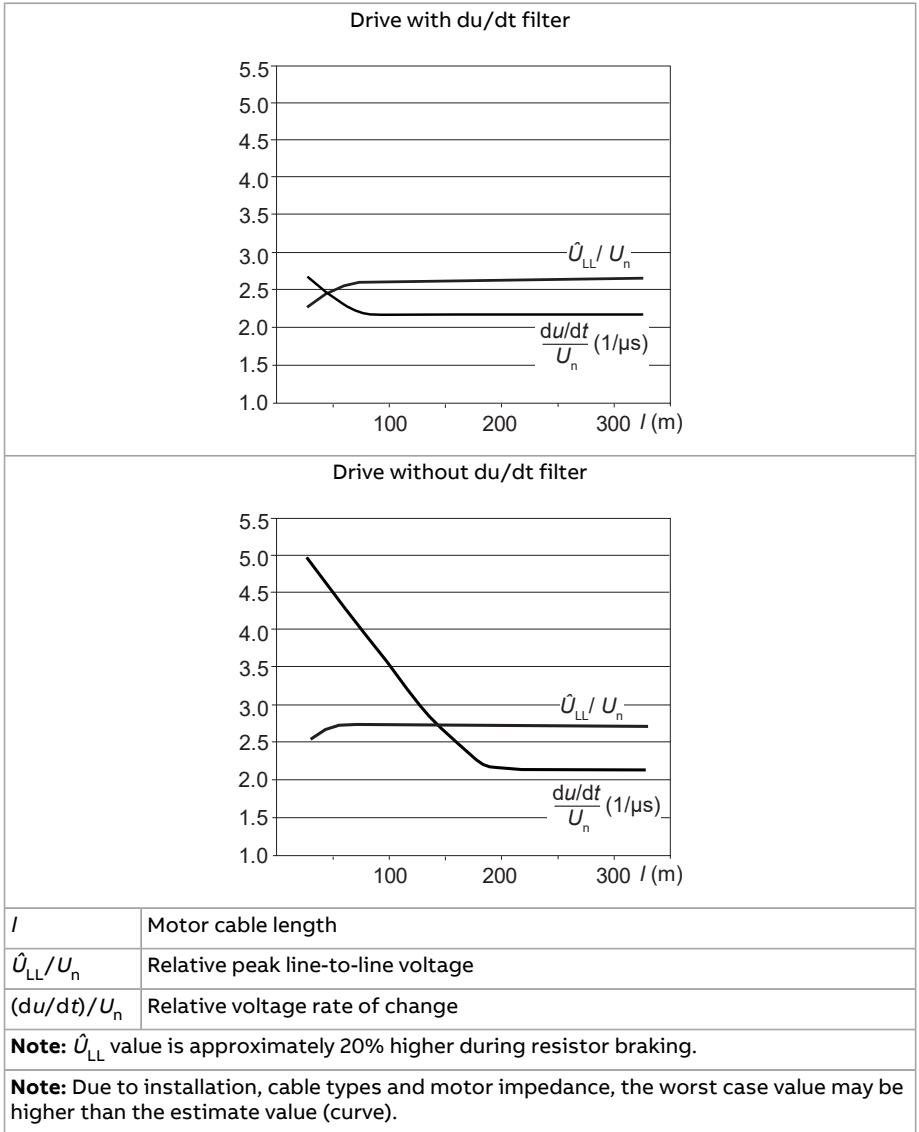

**Additional note for sine filters**

A sine filter also protects the motor insulation system. The peak phase-to-phase voltage with a sine filter is approximately  $1.5 \cdot U_n$ .

## Selecting the power cables

### ■ General guidelines

Select the input power and motor cables according to local regulations.

- **Current:** Select a cable capable of carrying the maximum load current and suitable for the prospective short-circuit provided by the supply network. The method of installation and ambient temperature affect the cable current carrying capacity. Obey local regulations and laws.
- **Temperature:** For an IEC installation, select a cable rated for at least 70 °C maximum permissible temperature of conductor in continuous use.  
Important: For certain product types or option configurations higher temperature rating may be required. See the [Technical data](#) for details.
- **Voltage:** 600 V AC cable is accepted for up to 500 V AC. 750 V AC cable is accepted for up to 600 V AC. 1000 V AC cable is accepted for up to 690 V AC.

To comply with the EMC requirements of the CE mark, use one of the preferred cable types. See [Preferred power cable types \(page 72\)](#).

Symmetrical shielded cable reduces electromagnetic emission of the whole drive system as well as the stress on motor insulation, bearing currents and wear.

Metal conduit reduces electromagnetic emission of the whole drive system.

### ■ Typical power cable sizes

See the [Technical data \(page 167\)](#).

### ■ Power cable types

#### Preferred power cable types

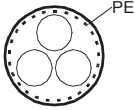

This section presents the preferred cable types. Make sure that the selected cable type also complies with local/state/country electrical codes.

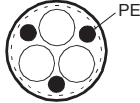
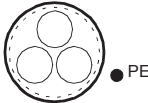
Cable type	Use as input power cabling	Use as motor cabling
 <p>Symmetrical shielded (or armored) cable with three phase conductors and concentric PE conductor as shield (or armor)</p>	Yes	Yes

Cable type	Use as input power cabling	Use as motor cabling
 <p>Symmetrical shielded (or armored) cable with three phase conductors and symmetrically constructed PE conductor and a shield (or armor)</p>	Yes	Yes
 <p>Symmetrical shielded (or armored) cable with three phase conductors and a shield (or armor), and separate PE conductor/cable<sup>1)</sup></p>	Yes	Yes

1) A separate PE conductor is required if the conductivity of the shield (or armor) is not sufficient for the PE use.

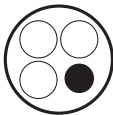
### Alternate power cable types

Cable type	Use as input power cabling	Use as motor cabling and as brake resistor cabling
 <p>Four-conductor cable in plastic jacket (three phase conductors and PE)</p>	Yes with phase conductor smaller than 10 mm <sup>2</sup> (8 AWG) Cu.	Yes with phase conductor smaller than 10 mm <sup>2</sup> (8 AWG) Cu, or motors up to 30 kW (40 hp). <b>Note:</b> Shielded or armored cable, or cabling in metal conduit is always recommended to minimize radio frequency interference.
 <p>Four-conductor armored cable (three phase conductors and PE)</p>	Yes	Yes with phase conductor smaller than 10 mm <sup>2</sup> (8 AWG) Cu, or motors up to 30 kW (40 hp)



## 74 Guidelines for planning the electrical installation

Cable type	Use as input power cabling	Use as motor cabling and as brake resistor cabling
 <p>Shielded (Al/Cu shield or armor)<sup>1)</sup> four-conductor cable (three phase conductors and a PE)</p>	Yes	Yes with motors up to 100 kW (135 hp). A potential equalization between the frames of motor and driven equipment is required.

<sup>1)</sup> Armor may act as an EMC shield, as long as it provides the same performance as a concentric EMC shield of a shielded cable. To be effective at high frequencies, the shield conductivity must be at least 1/10 of the phase conductor conductivity. The effectiveness of the shield can be evaluated based on the shield inductance, which must be low and only slightly dependent on frequency. The requirements are easily met with a copper or aluminum shield/armor. The cross-section of a steel shield must be ample and the shield helix must have a low gradient. A galvanized steel shield has a better high-frequency conductivity than a non-galvanized steel shield.

### Not allowed power cable types

Cable type	Use as input power cabling	Use as motor cabling
 <p>Symmetrical shielded cable with individual shields for each phase conductor</p>	No	No



#### ■ Power cable shield

If the cable shield is used as the sole protective earth (PE) conductor, make sure that its conductivity agrees with the PE conductor requirements.

To effectively suppress radiated and conducted radio-frequency emissions, the cable shield conductivity must be at least 1/10 of the phase conductor conductivity. The requirements are easily met with a copper or aluminum shield. The minimum requirement of the motor cable shield of the drive is shown below. It consists of a concentric layer of copper wires with an open helix of copper tape or copper wire. The better and tighter the shield, the lower the emission level and bearing currents.

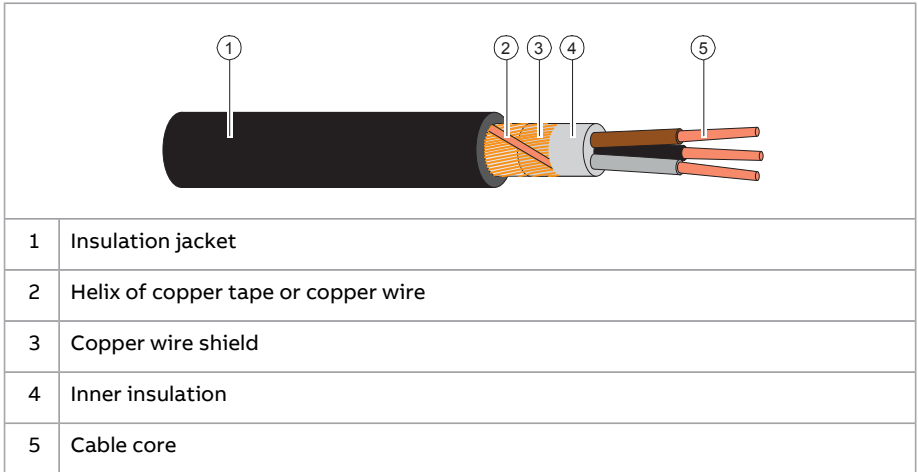

## Grounding requirements

This section gives general requirements for grounding the drive. When you plan the grounding of the drive, obey all the applicable national and local regulations.

The conductivity of the protective earth conductor(s) must be sufficient.

Unless local wiring regulations state otherwise, the cross-sectional area of the protective earth conductor must agree with the conditions that require automatic disconnection of the supply required in 411.3.2 of IEC 60364-4-41:2005 and be capable of withstanding the prospective fault current during the disconnection time of the protective device. The cross-sectional area of the protective earth conductor must be selected from the table below or calculated according to 543.1 of IEC 60364-5-54.

This table shows the minimum cross-sectional area of the protective earth conductor related to the phase conductor size according to IEC 61800-5-1 when the phase conductor(s) and the protective earth conductor are made of the same metal. If this is not so, the cross-sectional area of the protective earth conductor



must be determined in a manner which produces a conductance equivalent to that which results from the application of this table.

Cross-sectional area of the phase conductors $S$ (mm <sup>2</sup> )	Minimum cross-sectional area of the corresponding protective earth conductor $S_p$ (mm <sup>2</sup> )
$S \leq 16$	$S$ <sup>1)</sup>
$16 < S \leq 35$	16
$35 < S$	$S/2$

<sup>1)</sup> For the minimum conductor size in IEC installations, refer to [Additional grounding requirements – IEC](#).

If the protective earth conductor is not part of the input power cable or input power cable enclosure, the minimum permitted cross-sectional area is:

- 2.5 mm<sup>2</sup> if the conductor is mechanically protected,  
or
- 4 mm<sup>2</sup> if the conductor is not mechanically protected. If the equipment is cord-connected, the protective earth conductor must be the last conductor to be interrupted if there is a failure in the strain relief mechanism.

### ■ Additional grounding requirements – IEC

This section gives grounding requirements according to standard IEC/EN 61800-5-1.

Because the normal touch current of the drive is more than 3.5 mA AC or 10 mA DC:

- the minimum size of the protective earth conductor must comply with the local safety regulations for high protective earth conductor current equipment, and
- you must use one of these connection methods:
  1. a fixed connection and:
    - a protective earth conductor with a minimum cross-sectional area of 10 mm<sup>2</sup> Cu or 16 mm<sup>2</sup> Al (as an alternative when aluminum cables are permitted),  
or
    - a second protective earth conductor of the same cross-sectional area as the original protective earth conductor,  
or
    - a device that automatically disconnects the supply if the protective earth conductor is damaged.
  2. a connection with an industrial connector according to IEC 60309 and a minimum protective earth conductor cross-section of 2.5 mm<sup>2</sup> as part of a multi-conductor power cable. Sufficient strain relief must be provided.



If the protective earth conductor is routed through a plug and socket, or similar means of disconnection, it must not be possible to disconnect it unless power is simultaneously removed.

**Note:** You can use power cable shields as grounding conductors only when their conductivity is sufficient.

## Selecting the control cables

### ■ Shielding

Only use shielded control cables.

Use a double-shielded twisted pair cable for analog signals. ABB recommends this type of cable also for the pulse encoder signals. Use one individually shielded pair for each signal. Do not use common return for different analog signals.

A double-shielded cable (a) is the best alternative for low-voltage digital signals, but single-shielded (b) twisted pair cable is also acceptable.

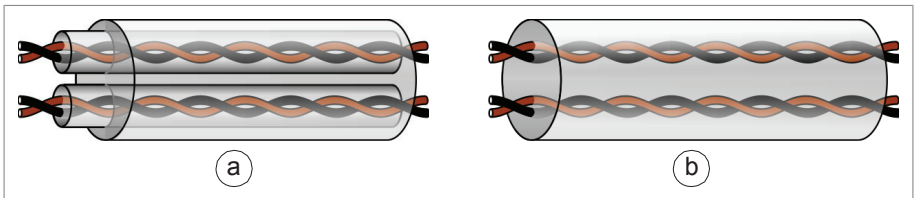

### ■ Signals in separate cables

Run analog and digital signals in separate, shielded cables. Do not mix 24 V DC and 115/230 V AC signals in the same cable.

### ■ Signals that can be run in the same cable

If their voltage does not exceed 48 V, relay-controlled signals can be run in the same cables as digital input signals. The relay-controlled signals should be run as twisted pairs.

### ■ Relay cable

The cable type with braided metallic shield (for example ÖLFLEX by LAPPKABEL, Germany) has been tested and approved by ABB.

### ■ Control panel to drive cable

Use EIA-485, Cat 5e (or better) cable with male RJ-45 connectors. The maximum length of the cable is 100 m .



■ **PC tool cable**

Connect the Drive composer PC tool to the drive through the USB port of the control panel. Use a USB Type A (PC) - Type Mini-B (control panel) cable. The maximum length of the cable is 3 m.

■ **FPBA-01 PROFIBUS DP adapter module connectors**

Frames R1...R3: The following connector types have been tested to fit in the tight space for option slot 1.

- Phoenix Contact SUBCON-PLUS-PROFIB/PG/SC2, part number 2708245. Lead the cable through the control cable hole on the right in the entry plate (1).
- Siemens, part number 6GK1 500 0EA02. Lead the cable through the middle control cable hole in the entry plate (2).

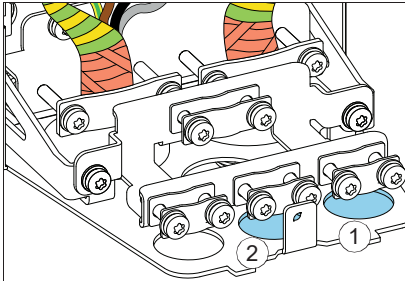

## Routing the cables

■ **General guidelines – IEC**

- Route the motor cable away from other cables. Motor cables of several drives can be run in parallel installed next to each other.
- Install the motor cable, input power cable and control cables on separate trays.
- Avoid long parallel runs of motor cables with other cables.
- Where control cables must cross power cables, make sure that they are arranged at an angle as near to 90 degrees as possible.
- Do not run extra cables through the drive.
- Make sure that the cable trays have good electrical bonding to each other and to the grounding electrodes. Aluminum tray systems can be used to improve local equalizing of potential.

The following figure illustrates the cable routing guidelines with an example drive.



**Note:** When motor cable is symmetrical and shielded and it has short parallel runs with other cables (< 1.5 m), distances between the motor cable and other cables can be reduced by half.

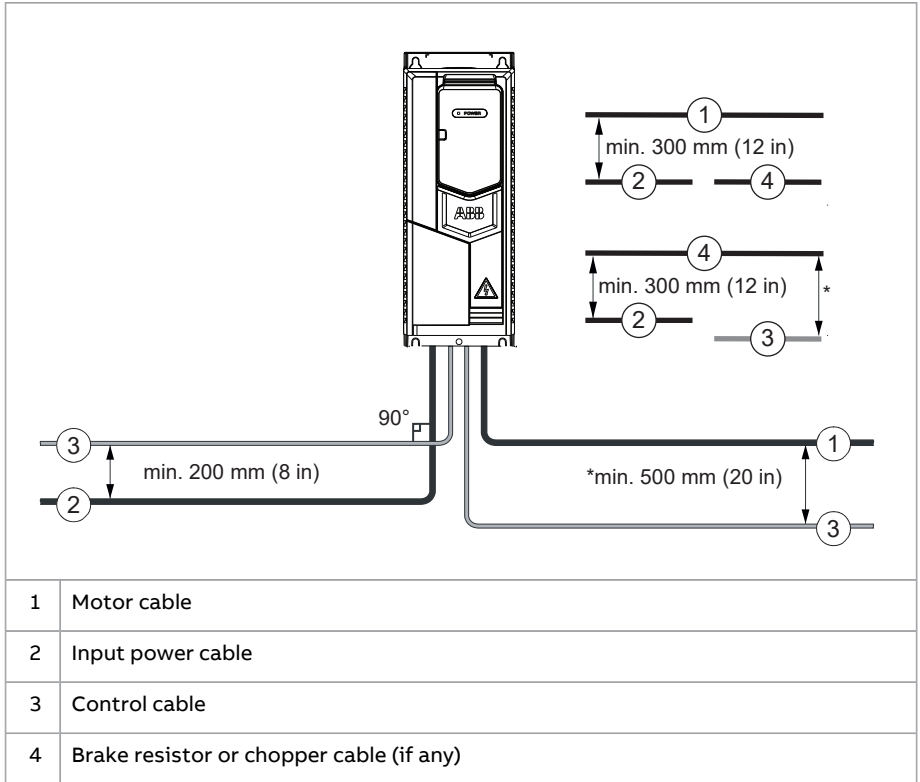

### ■ Continuous motor cable shield/conduit or enclosure for equipment on the motor cable

To minimize the emission level when safety switches, contactors, connection boxes or similar equipment are installed on the motor cable between the drive and the motor:

- Install the equipment in a metal enclosure.
- Use either a symmetrical shielded cable, or install the cabling in a metal conduit.
- Make sure that there is a good and continuous galvanic connection in the shield/conduit between drive and motor.
- Connect the shield/conduit to the protective ground terminal of the drive and the motor.

### ■ Separate control cable ducts

Put 24 V DC and 230 V AC (120 V AC) control cables in separate ducts, unless the 24 V DC cable is insulated for 230 V AC (120 V AC) or insulated with an insulation sleeving for 230 V AC (120 V AC).

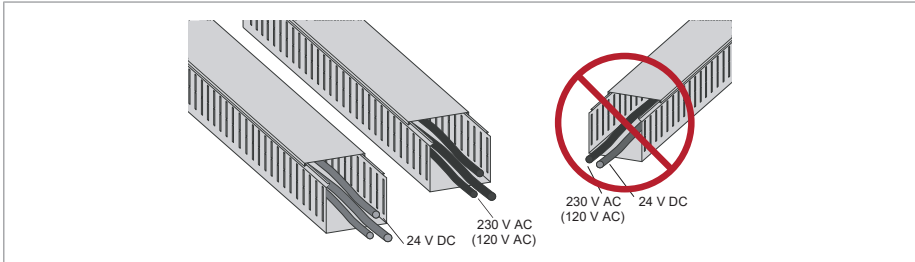

## Implementing short-circuit and thermal overload protection

### ■ Protecting the drive and the input power cable in short-circuits

Protect the drive and the input cable with fuses or a circuit breaker.

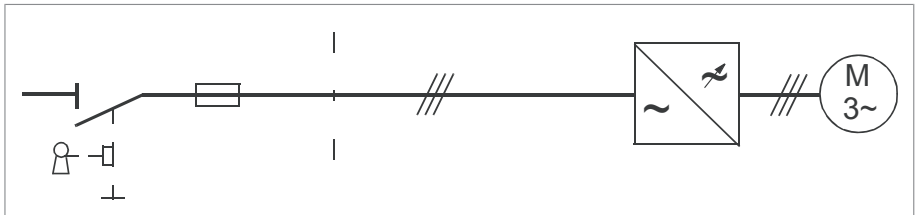

Select the fuses or circuit breakers according to local regulations for the input cable protection. Select the fuses or circuit breakers for the drive according to the instructions given in the technical data. The fuses or circuit breakers for the drive protection will restrict drive damage and prevent damage to adjoining equipment in case of a short-circuit inside the drive.

**Note:** If the fuses or circuit breakers for the drive protection are placed at the distribution board and the input cable is selected according to the nominal input current of the drive given in the technical data, the fuses or circuit breakers protect also the input cable in short-circuit situations, restrict drive damage and prevent damage to adjoining equipment in case of a short-circuit inside the drive. No separate fuses or circuit breakers for the input cable protection are required.



**WARNING!**

Due to the inherent operating principle and construction of circuit breakers, independent of the manufacturer, hot ionized gases can escape from the breaker enclosure in case of a short-circuit. To make sure of safe use, pay special attention to the installation and placement of the breakers. Obey the manufacturer's instructions.

---

**■ Protecting the motor and motor cable in short-circuits**

The drive protects the motor cable and motor in a short-circuit situation when:

- the motor cable is sized correctly
- the motor cable type complies with the motor cable selection guidelines by ABB
- the cable length does not exceed the allowed maximum length specified for the drive
- the setting of parameter 99.10 Motor nominal power in the drive is equal with the value given on the motor rating plate.

The electronic power output short-circuit protection circuitry meets the requirements of IEC 60364-4-41:2005 + AMD1:2017.

**■ Protecting the motor cables against thermal overload**

The drive protects the motor cables against thermal overload when the cables are sized according to the nominal output current of the drive. No additional thermal protection devices are needed.

---

**WARNING!**

If the drive is connected to multiple motors, use a separate overload protection for each motor cable and motor. The drive overload protection is tuned for the total motor load. It may not detect an overload in one motor circuit only.

---

**■ Protecting the motor against thermal overload**

According to regulations, the motor must be protected against thermal overload and the current must be switched off when overload is detected. The drive includes a motor thermal protection function that protects the motor and switches off the current when necessary. Depending on a drive parameter value, the function either monitors a calculated temperature value (based on a motor thermal model) or an actual temperature indication given by motor temperature sensors.

The motor thermal protection model supports thermal memory retention and speed sensitivity. The user can tune the thermal model further by feeding in additional motor and load data.

---



The most common temperature sensor types are PTC or Pt100.

For more information, see the firmware manual.

### ■ **Protecting the motor against overload without thermal model or temperature sensors**

Motor overload protection protects the motor against overload without using motor thermal model or temperature sensors.

Motor overload protection is required and specified by the common IEC 61800-5-1 standard in conjunction with IEC 60947-4-1. The standards allow for motor overload protection without external temperature sensors.

The protection feature allows the user to specify the class of operation in the same manner as the overload relays are specified in standards IEC 60947-4-1.

The motor overload protection supports thermal memory retention and speed sensitivity.

For more information, see drive firmware manual.

## **Protecting the drive against ground faults**

The drive is equipped with an internal ground fault protective function to protect the unit against ground faults in the motor and motor cable. This function is not a personnel safety or a fire protection feature. See the firmware manual for more information.

### ■ **Residual current device compatibility**

The drive is suitable for use with residual current devices of Type B.

**Note:** As standard, the drive contains capacitors connected between the main circuit and the frame. These capacitors and long motor cables increase the ground leakage current and may cause nuisance faults in residual current devices.

## **Implementing the emergency stop function**

For safety reasons, install the emergency stop devices at each operator control station and at other operating stations where the emergency stop may be needed. Implement the emergency stop according to relevant standards.

**Note:** You can use the Safe torque off function of the drive to implement the Emergency stop function.

## **Implementing the Safe torque off function**

See [The Safe torque off function \(page 219\)](#).

---

## Using power factor compensation capacitors with the drive

Power factor compensation is not needed with AC drives. However, if a drive is to be connected in a system with compensation capacitors installed, note the following restrictions.



### WARNING!

Do not connect power factor compensation capacitors or harmonic filters to the motor cables (between the drive and the motor). They are not meant to be used with AC drives and can cause permanent damage to the drive or themselves.

If there are power factor compensation capacitors in parallel with the input of the drive:

1. Do not connect a high-power capacitor to the power line while the drive is connected. The connection will cause voltage transients that may trip or even damage the drive.
2. If capacitor load is increased/decreased step by step when the AC drive is connected to the power line, make sure that the connection steps are low enough not to cause voltage transients that would trip the drive.
3. Make sure that the power factor compensation unit is suitable for use in systems with AC drives, ie, harmonic generating loads. In such systems, the compensation unit should typically be equipped with a blocking reactor or harmonic filter.

## Controlling a contactor between drive and motor

The control of the output contactor depends on how you use the drive, that is, which motor control mode and which motor stop mode you select.

1. Give a stop command to the drive.
2. Open the contactor.

## Implementing a bypass connection

If bypassing is required, employ mechanically or electrically interlocked contactors between the motor and the drive and between the motor and the power line. Make sure with interlocking that the contactors cannot be closed simultaneously. The installation must be clearly marked as defined in IEC/EN 61800-5-1, subclause 6.5.3, for example, “THIS MACHINE STARTS AUTOMATICALLY”.



### WARNING!

Never connect the drive output to the electrical power network. The connection may damage the drive.



■ **Example bypass connection**

An example bypass connection is shown below.

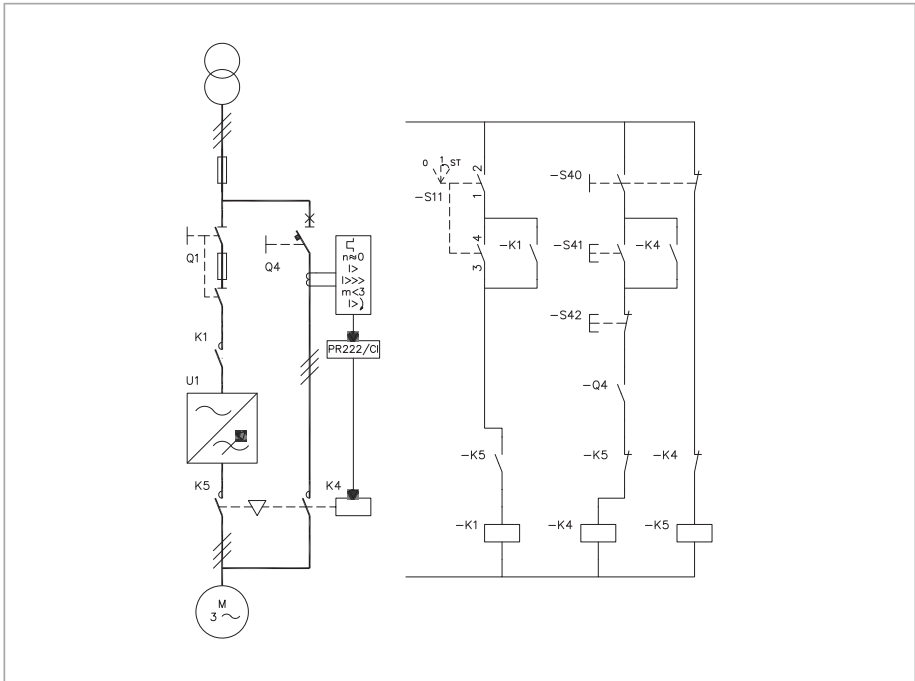

Q1	Drive main switch
Q4	Bypass circuit breaker
K1	Drive main contactor
K4	Bypass contactor
K5	Drive output contactor
S11	Drive main contactor on/off control
S40	Motor power supply selection (drive or direct-on-line)
S41	Start when motor is connected direct-on-line
S42	Stop when motor is connected direct-on-line



### Switching the motor power supply from drive to direct-on-line

1. Stop the drive and the motor with the drive control panel stop key (drive in the local control mode) or the external stop signal (drive in the remote control mode).
2. Open the main contactor of the drive with S11.
3. Switch the motor power supply from the drive to direct-on-line with S40.
4. Wait for 10 seconds to allow the motor magnetization to dissipate.
5. Start the motor with S41.

### Switching the motor power supply from direct-on-line to drive

1. Stop the motor with S42.
2. Switch the motor power supply from direct-on-line to the drive with S40.
3. Close the main contactor of the drive with switch S11 (-> turn to position ST for two seconds and leave to position 1).
4. Start the drive and the motor with the drive control panel start key (drive in the local control mode) or the external start signal (drive in remote control mode).

## Protecting the contacts of relay outputs

Inductive loads (relays, contactors, motors) cause voltage transients when switched off.

It is highly recommended that inductive loads are equipped with noise attenuating circuits (varistors, RC filters [AC] or diodes [DC]) to minimize the EMC emission at switch-off. If not suppressed, the disturbances can connect capacitively or inductively to other conductors in the control cable and form a risk of malfunction in other parts of the system.

Install the protective component as close to the inductive load as possible. Do not install protective components at the relay outputs.



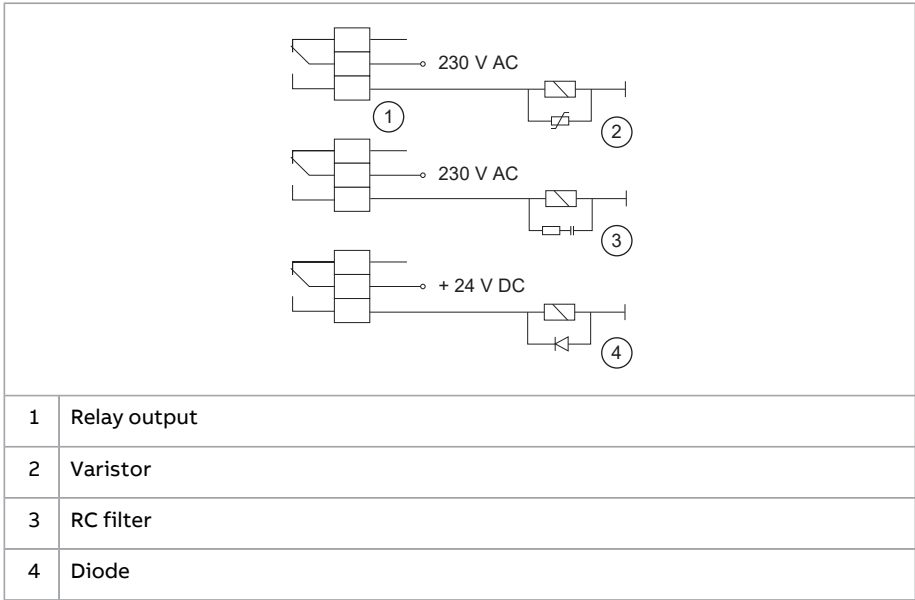

## Limiting relay output maximum voltages at high installation altitudes

See [Isolation areas, R1...R5](#) and [Isolation areas, R6...R9](#).

## Implementing a motor temperature sensor connection



**WARNING!**

IEC 61800-5-1 requires double or reinforced insulation between live parts and accessible parts when:

- the accessible parts are not conductive, or
- the accessible parts are conductive, but not connected to the protective earth.

Obey this requirement when you plan the connection of the motor temperature sensor to the drive.

To connect a motor temperature sensor and other similar components to the drive, you have four alternatives:

1. If there is double or reinforced insulation between the sensor and the live parts of the motor, you can connect the sensor directly to the analog/digital input(s) of the drive. See the control cable connection instructions. Make sure that the voltage is not more than the maximum allowed voltage over the sensor.

2. If there is basic insulation between the sensor and the live parts of the motor, or if the insulation type is not known: You can connect the sensor to the drive via an option module. The sensor and the module must form a double or reinforced insulation between the motor live parts and the drive control unit. See section [Connection of motor temperature sensor to the drive via an option module \(page 100\)](#). Make sure that the voltage does not exceed the maximum allowed voltage over the sensor.
3. If there is basic insulation between the sensor and the live parts of the motor, or if the insulation type is not known: You can connect a sensor to a digital input of the drive via an external relay. The sensor and the relay must form a double or reinforced insulation between the motor's live parts and the digital input of the drive. Make sure that the voltage does not exceed the maximum allowed voltage over the sensor.

### ■ **Connecting a motor temperature sensor to the drive through an option module**

This table shows:

- option module types that you can use for the motor temperature sensor connection
- insulation or isolation level that each option module forms between its temperature sensor connector and other connectors
- temperature sensor types that you can connect to each option module
- temperature sensor insulation requirement in order to form, together with the insulation of the option module, a reinforced insulation between the motor live parts and the drive control unit.





# 6

## Electrical installation-IEC

---

### Contents of this chapter

This chapter describes how to:

- measure the insulation
- do the grounding system compatibility check
- change the EMC filter or ground-to-phase varistor connection
- connect the power and control cables
- install optional modules
- connect a PC.



#### **WARNING!**

Obey the safety instructions of the drive. If you ignore them, injury or death, or damage to the equipment can occur. If you are not a qualified electrical professional, do not do installation, commissioning or maintenance work.

Make sure that the drive is disconnected from the input power during installation. If the drive is already connected to the input power, wait for 5 minutes after disconnecting the input power.



### Required tools

To do the electrical installation, you need these tools:

- wire stripper
  - screwdriver set (Torx, Phillips, flat and/or Pozidriv, as appropriate)
-

- torque wrench.

## Grounding the motor cable shield at the motor end

For minimum radio-frequency interference, ground the cable shield 360° at the cable entry of the motor terminal box.

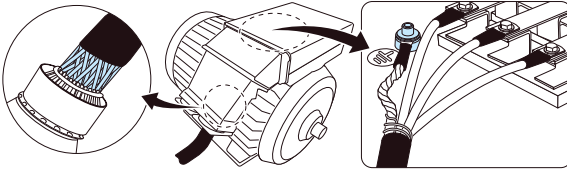

## Measuring the insulation

### ■ Measuring the insulation resistance of the drive



#### **WARNING!**

Do not do voltage withstand or insulation resistance tests on the drive. The tests can cause damage to the drive. Every drive is tested for insulation between the main circuit and the chassis at the factory. Also, there are voltage-limiting circuits inside the drive which cut down the testing voltage automatically.

### ■ Measuring the insulation resistance of the input power cable

Before you connect the input power cable to the drive, measure its insulation resistance according to local regulations.

### ■ Measuring the insulation resistance of the motor and motor cable



#### **WARNING!**

Obey the safety instructions of the drive. If you ignore them, injury or death, or damage to the equipment can occur. If you are not a qualified electrical professional, do not do installation, commissioning or maintenance work.

1. Do the steps in section [Electrical safety precautions \(page 20\)](#) before you start the work.
2. Make sure that the motor cable is disconnected from the drive output terminals.
3. Measure the insulation resistance between each phase conductor and the protective earth conductor. Use a measuring voltage of 1000 V DC. The insulation resistance of an ABB motor must be more than 100 Mohm (reference value at 25 °C). For the insulation resistance of other motors, refer to the manufacturer's instructions.

**Note:** Moisture inside the motor reduces the insulation resistance. If you think that there is moisture in the motor, dry the motor and do the measurement again.

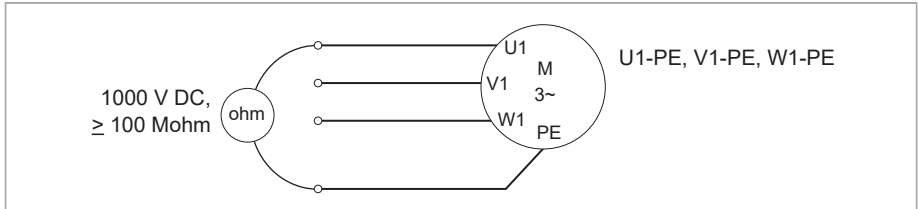

### ■ Brake resistor assembly for R1...R3



#### **WARNING!**

Obey the safety instructions of the drive. If you ignore them, injury or death, or damage to the equipment can occur. If you are not a qualified electrical professional, do not do installation, commissioning or maintenance work.

1. Stop the drive and do the steps in section [Electrical safety precautions \(page 20\)](#) before you start the work.
2. Make sure that the resistor cable is connected to the resistor and disconnected from the drive output terminals.
3. At the drive end, connect the R+ and R- conductors of the resistor cable together. Measure the insulation resistance between the conductors and the PE conductor with a measuring voltage of 1000 V DC. The insulation resistance must be more than 1 Mohm.

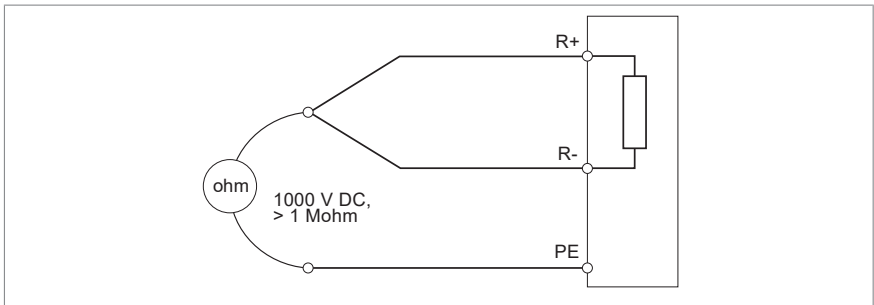

## Grounding system compatibility check

The standard drive can be installed to a symmetrically grounded TN-S system. For other systems, see sections [EMC filter](#) and [Ground-to-phase varistors \(page 92\)](#) below.

■ **EMC filter**

A drive with EMC filter connected can be installed to a symmetrically grounded TN-S system. If you install the drive to another system, you may need to disconnect the EMC filter. See sections [When to disconnect EMC filter or ground-to-phase varistor: TN-S, IT, corner-grounded delta and midpoint-grounded delta systems \(page 92\)](#), and [Guidelines for installing the drive to a TT system \(page 94\)](#).

 **WARNING!** Do not install the drive with the EMC filter connected to a system that the filter is not suitable for. This can cause danger, or damage the drive.

**Note:** When the internal EMC filter is disconnected, the drive EMC compatibility is considerably reduced. See [EMC compatibility and motor cable length \(page 191\)](#).

■ **Ground-to-phase varistors**

A drive with the ground-to-phase varistor connected can be installed to a symmetrically grounded TN-S system. If you install the drive to another system, you may need to disconnect the varistor. See sections [When to disconnect EMC filter or ground-to-phase varistor: TN-S, IT, corner-grounded delta and midpoint-grounded delta systems \(page 92\)](#), and [Guidelines for installing the drive to a TT system \(page 94\)](#).

 **WARNING!** Do not install the drive with the ground-to-phase varistor connected to a system that the varistor is not suitable for. It can cause damage to the varistor circuit.

■ **When to disconnect EMC filter or ground-to-phase varistor: TN-S, IT, corner-grounded delta and midpoint-grounded delta systems**

Requirements for disconnecting EMC filter and varistor and additional requirements for different electrical power systems are given below.

Frame size	Symmetrically grounded TN systems (TN-S systems) ie. center-grounded wye (A)	Corner-grounded (B1) and midpoint-grounded delta systems (B2) ≤ 600 V	IT systems (ungrounded or high-resistance grounded [>30 ohms]) (C)
R1...R3 R4 v2	Do not disconnect EMC or VAR screws.	Disconnect EMC screw. Do not disconnect VAR screw.	Disconnect EMC and VAR screws.
R4...R5	Do not disconnect EMC or VAR screws.	Not evaluated <sup>1)</sup>	Disconnect EMC screws (2 pcs) and VAR screw.



<b>Frame size</b>	<b>Symmetrically grounded TN systems (TN-S systems) ie. center-grounded wye (A)</b>	<b>Corner-grounded (B1) and midpoint-grounded delta systems (B2) ≤ 600 V</b>	<b>IT systems (ungrounded or high-resistance grounded [<math>&gt;30</math> ohms]) (C)</b>
R6...R9	Do not disconnect EMC or VAR screws.	Do not disconnect EMC AC or VAR screws. Disconnect EMC DC screw.	Disconnect EMC screws (2 pcs) and VAR screw.

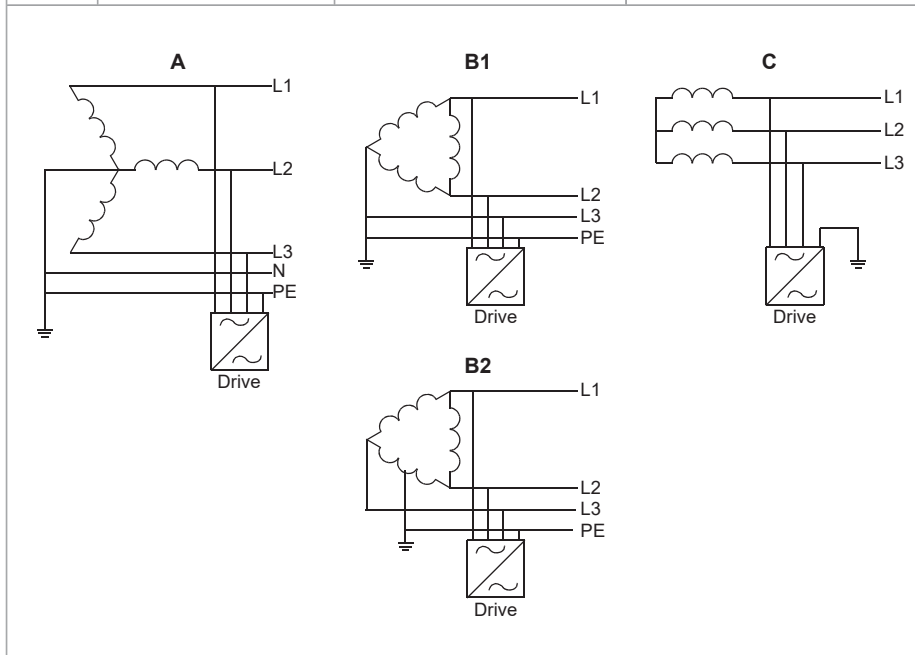

1) Frames R4 and R5 are not evaluated for use on corner-grounded systems or midpoint-grounded delta systems by IEC standards.

**Note:** These are the EMC filter and varistor screws of different drive frame sizes.

<b>Frame size</b>	<b>EMC filter screws</b>	<b>Ground-to-phase varistor screws</b>
R1...R3 R4 v2	EMC screw	VAR
R4...R5	Two EMC screws	VAR
R6...R9	Two EMC screws	VAR



■ **Guidelines for installing the drive to a TT system**

The drive can be installed to a TT system under these conditions:

1. Residual current device has been installed in the supply system.
2. These screws have been disconnected. Otherwise EMC filter and ground-to-phase varistor capacitor leakage current will cause the residual current device to trip.

Frame size	EMC filter screws	Ground-to-phase varistor screws
R1...R3 R4 v2	EMC screw	VAR
R4...R5	Two EMC screws	VAR
R6...R9	Two EMC screws	VAR

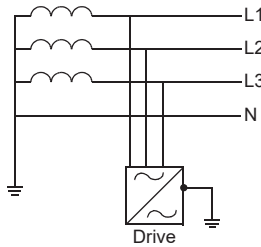

**Note:**

- Because the EMC filter screws have been disconnected, ABB does not guarantee the EMC category.
- ABB does not guarantee the functioning of the ground leakage detector built inside the drive.
- In large systems the residual current device can trip without a reason.



## ■ Identifying the grounding system of the electrical power network



### WARNING!

Only a qualified electrical professional may do the work instructed in this section. Depending on the installation site, the work may even be categorized as live working. Continue only if you are an electrical professional certified for the work. Obey the local regulations. If you ignore them, injury or death can occur.

To identify the grounding system, examine the supply transformer connection. See the applicable electrical diagrams of the building. If that is not possible, measure these voltages at the distribution board, and use the table to define the grounding system type.

1. input voltage line to line ( $U_{L-L}$ )
2. input voltage line 1 to ground ( $U_{L1-G}$ )
3. input voltage line 2 to ground ( $U_{L2-G}$ )
4. input voltage line 3 to ground ( $U_{L3-G}$ ).

The table below shows the line-to-ground voltages in relation to the line-to-line voltage for each grounding system.

$U_{L-L}$	$U_{L1-G}$	$U_{L2-G}$	$U_{L3-G}$	Electrical power system type
X	0.58·X	0.58·X	0.58·X	TN-S system (symmetrically grounded)
X	1.0·X	1.0·X	0	Corner-grounded delta system (nonsymmetrical)
X	0.866·X	0.5·X	0.5·X	Midpoint-grounded delta system (nonsymmetrical)
X	Varying level versus time	Varying level versus time	Varying level versus time	IT systems (ungrounded or high-resistance-grounded [ $>30$ ohms]) nonsymmetrical
X	Varying level versus time	Varying level versus time	Varying level versus time	TT system (the protective earth connection for the consumer is provided by a local earth electrode, and there is another independently installed at the generator)



■ **Disconnecting internal EMC filter or ground-to-phase varistor - frames R1...R3**

To disconnect the internal EMC filter or ground-to-phase varistor, if needed, do as follows:

1. Switch off the power from the drive.
2. Open the front cover, if not already opened, see page 100.
3. To disconnect the internal EMC filter, remove the EMC screw (3a) and place it in the storage place (3b).
4. To disconnect the ground-to-phase varistor, remove the varistor screw (4a) and place it in the storage place (4b)

R1

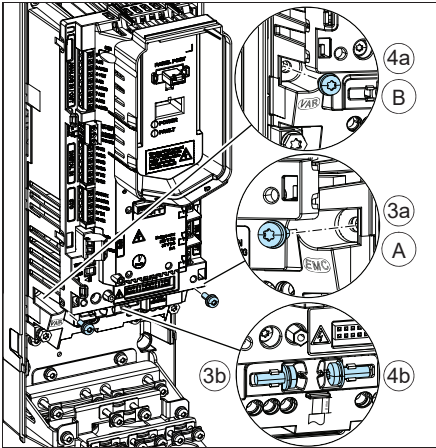

R2

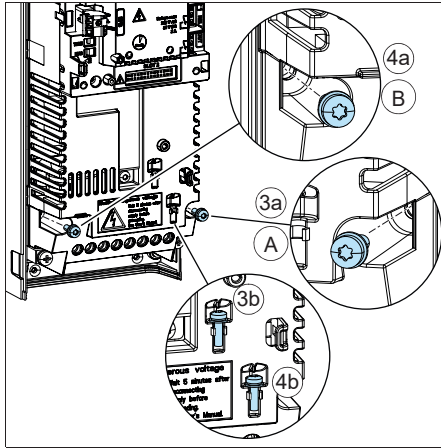

R3



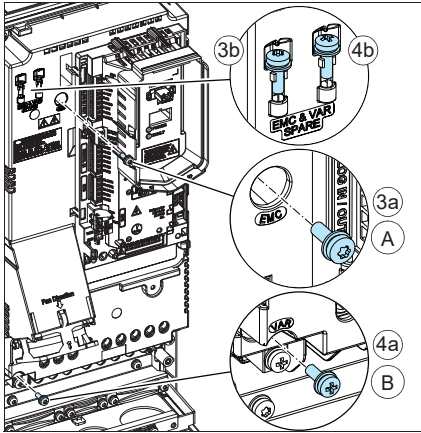

	Screw
A	EMC (DC)
B	VAR

Note: Drive with cable box is used as an example in the figure. Cable box is optional and need to be ordered separately.

### ■ Disconnecting internal EMC filter or ground-to-phase varistor - frames R4...R9

To disconnect the internal EMC filter or ground-to-phase varistor, if needed, do as follows:

1. Switch off the power from the drive.
2. Open the cover, if not already opened.
3. To disconnect the internal EMC filter, remove the EMC screw(s).
4. To disconnect the ground-to-phase varistor, remove the varistor screw.



R4 v2

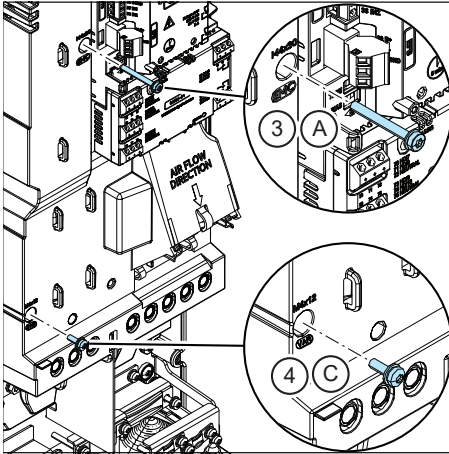

R4

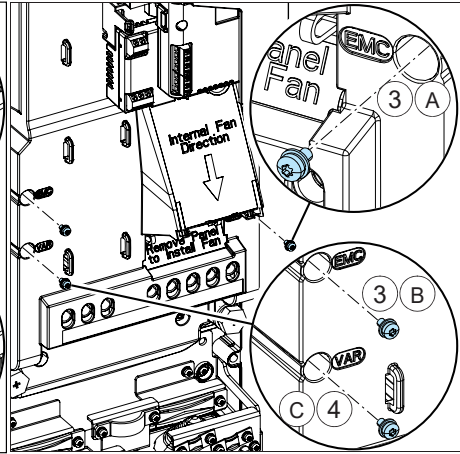

R5

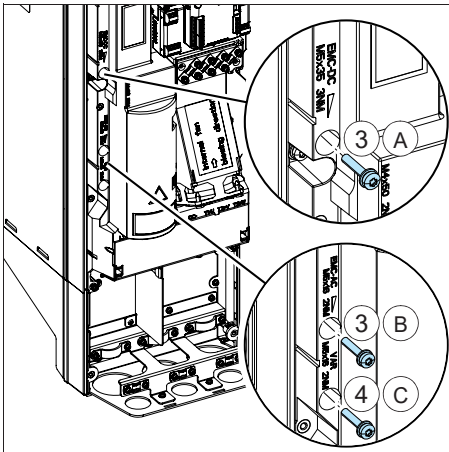

R6...R9

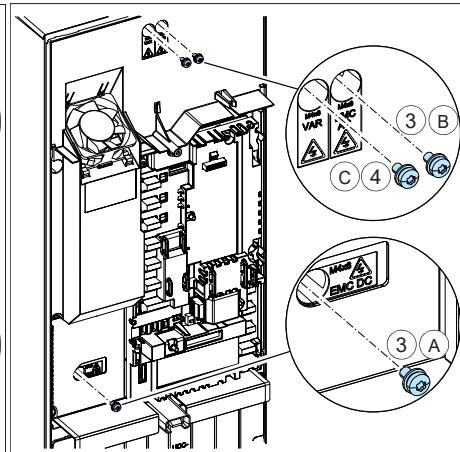

	Screw
A	EMC (DC)
B	EMC (AC)
C	VAR

Note: Drive with cable box is used as an example in the figure. Cable box is optional and need to be ordered separately.

## Connecting the power cables

### ■ Connection diagram

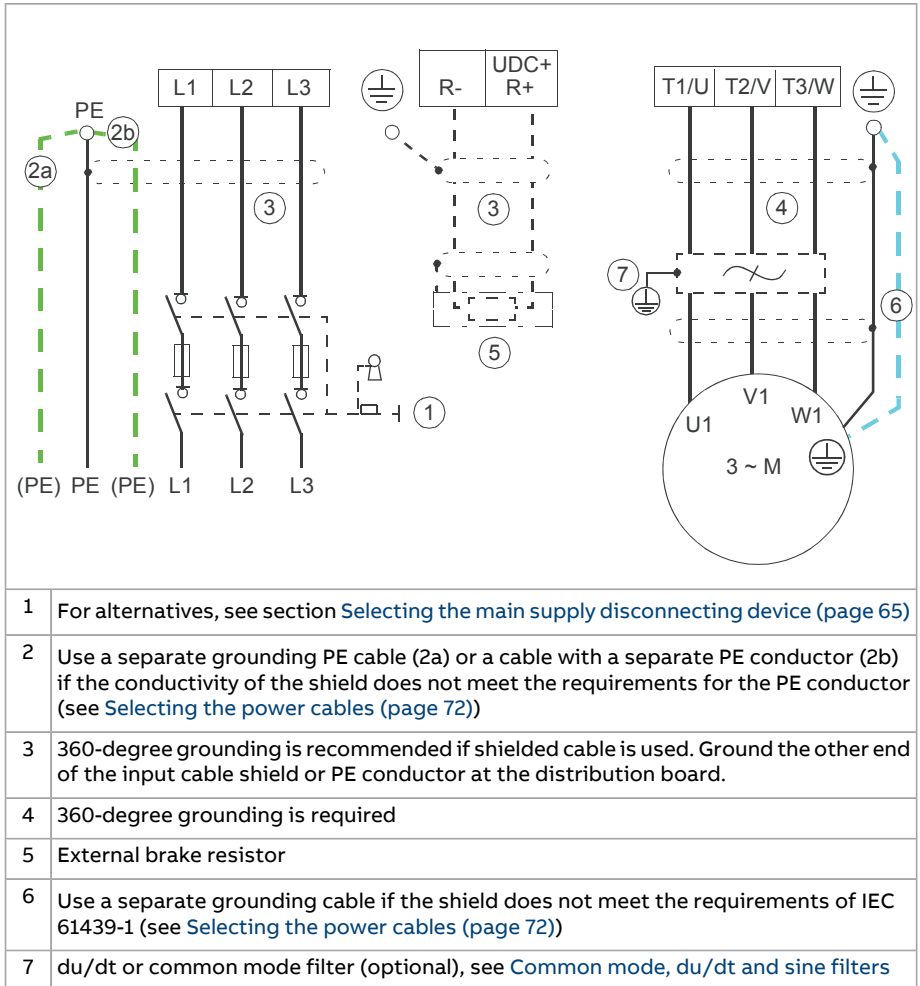

**Note:** Frames R1...R3 have a built-in brake chopper. If necessary, you can connect a brake resistor to terminals R-and UDC+/R+. The brake resistor is not included in the drive delivery. In frames R4...R9, you can connect an external brake chopper to terminals UDC+ and UDC-. The brake chopper is not included in the drive delivery.

Do not use an asymmetrically constructed motor cable for motors above 30 kW (see section [General guidelines \(page 72\)](#)). Connecting its fourth conductor at the motor end increases bearing currents and causes extra wear.

For a single phase connection, use terminals L1 and L2.

■ **Connection procedure, frames R1...R4**

1. Remove the front cover: Loosen the retaining screw with a T20 Torx screwdriver (1a) and lift the cover from the bottom outwards (1b) and then up (1c).

IP20,  
R1...R2

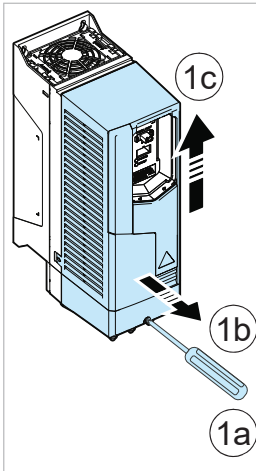

IP20,  
R3...R4

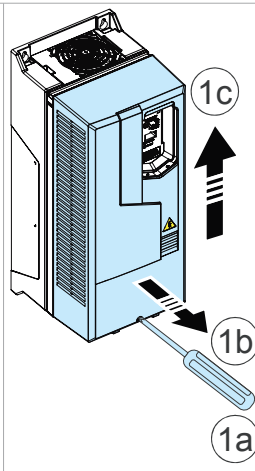

**WARNING!**

If you install the drive on any other system than symmetrically grounded TN-S system, see [Grounding system compatibility check \(page 91\)](#) if you have to disconnect the EMC filter and ground-to-phase varistor.

2. Attach the residual voltage warning sticker in the local language.

R1

R2

R3...R4

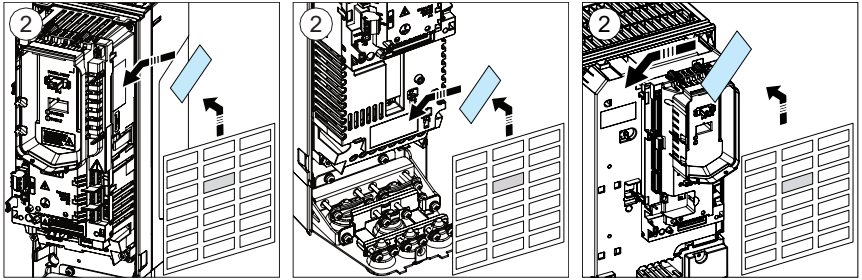

Note: Drive with cable box is used as an example in the figure. Cable box is optional and need to be ordered separately.



**Motor cable**

3. Prepare the ends of the cable as illustrated in the figures. In frames R1 and R2 there are markings on the drive frame near the power cable terminals helping you to strip the wires to the correct length of 8 mm. Two different motor cable types are shown (6a, 6b).

**Note:** The bare shield will be grounded 360 degrees. Mark the pigtail made from the shield as a PE conductor with yellow-and-green colour.

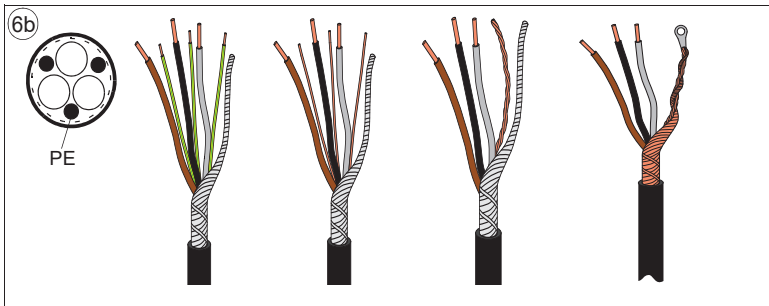
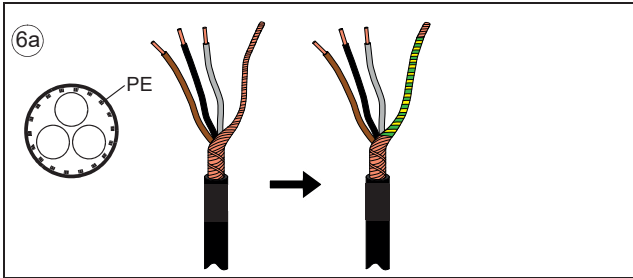

4. Connect the motor cable:
  - Ground the shield 360 degrees by tightening the clamp of the power cable grounding shelf onto the stripped part of the cable. (7a)
  - If you need more working space, open the screw (7d) and lift the EMC plate off. Remember to put it back after you have installed motor and input power cables.
  - Connect the twisted shield of the cable to the grounding terminal. (7b)
  - Connect the phase conductors of the cable to the T1/U, T2/V and T3/W terminals. Tighten the screws to the torque given in the table below (7c).



R1...R2

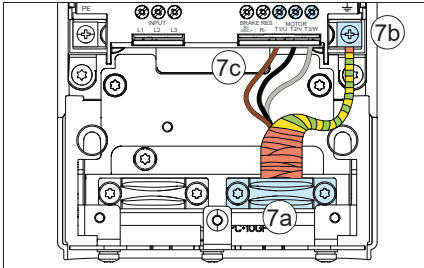

R3

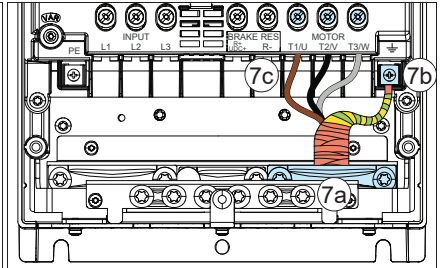

R4 v2

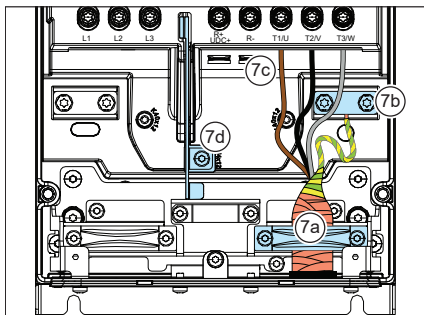

R4

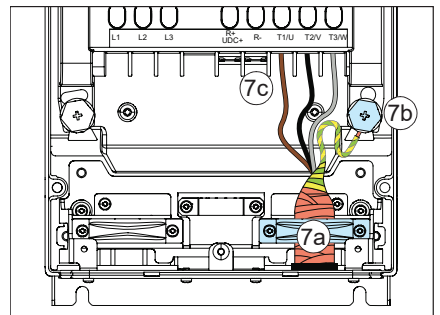

Frame size	R1	R2	R3	R4	R4 v2
	N-m	N-m	N-m	N-m	N-m
T1/U, T2/V, T3/W	1.0	1.5	3.5	4.0	5.5
PE, ⊕	1.5	1.5	1.5	2.9	2.9
	1.2	1.2	1.2	1.2	1.2

Note: Drive with cable box is used as an example in the figure. Cable box is optional and need to be ordered separately.

### Input power cable

5. Prepare the ends of the cable as illustrated in the figure.

**Note:** The bare shield will be grounded 360 degrees. Mark the pigtail made from the shield as a PE conductor with yellow-and-green colour.



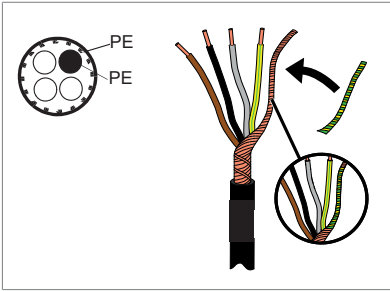

6. Connect the input power cable:
- Ground the shield 360 degrees by tightening the clamp of the power cable grounding shelf onto the stripped part of the cable (11a).
  - Connect the twisted shield of the cable to the grounding terminal (11b).
  - Connect the additional PE conductor of the cable (11c) (see the note in section [Additional instructions and notes \(page 21\)](#)).
  - Connect the phase conductors of the cable to the L1, L2 and L3 terminals. Tighten the screws to the torque given below in the table (11d).

R1...R2

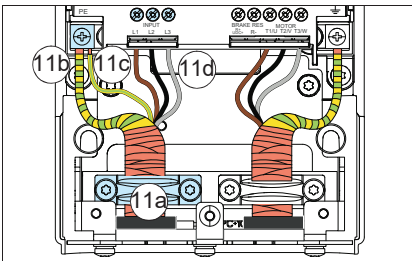

R3

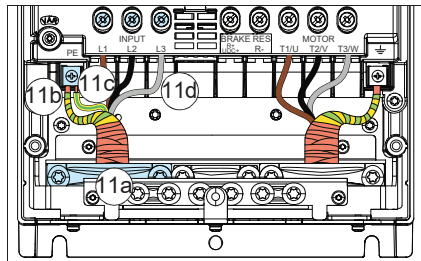

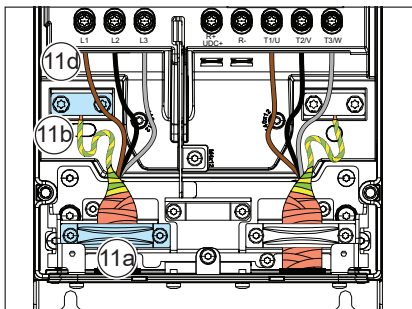

R4 v2

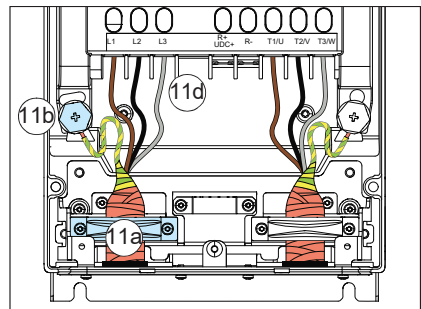

R4



Frame size	R1	R2	R3	R4	R4 v2
	N-m	N-m	N-m	N-m	N-m
L1, L2, L3	1.0	1.5	3.5	4.0	5.5
PE, 	1.5	1.5	1.5	2.9	2.9
	1.2	1.2	1.2	1.2	1.2

Note: Drive with cable box is used as an example in the figure. Cable box is optional and need to be ordered separately.

**Brake resistor cable (if used)**

Frames R1...R3 only

- Repeat steps 4...6 for the brake resistor cable. Cut off one phase conductor.

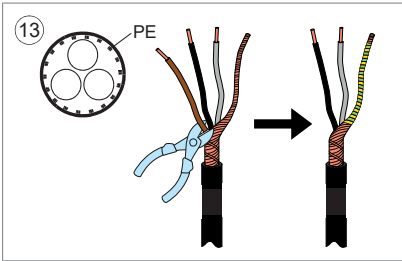



- Connect the cable as the motor cable in step 7. Ground the shield 360 degrees (14a). Connect the twisted shield to the grounding terminal (14b) and the conductors to the R+ and R- terminals (14c) and tighten to the torque given in the table.

**R1...R2**

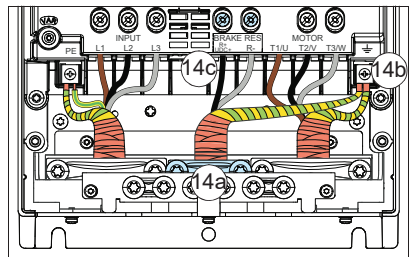
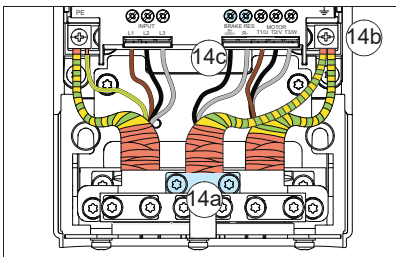
**R3**



Frame size	R1	R2	R3
	N-m	N-m	N-m

<b>R+, R-</b>	1.0	1.5	3.5
<b>PE, </b>	1.5	1.5	1.5
	1.2	1.2	1.2

Note: Drive with cable box is used as an example in the figure. Cable box is optional and need to be ordered separately.

**Finalization**

**Note:** Frame R1: You have to install any optional I/O extension module, if used, in options slot 2 at this point. See section [Installing option modules \(page 122\)](#).

- Secure the cables outside the unit mechanically.
- Ground the motor cable shield at the motor end. For minimum radio frequency interference, ground the motor cable shield 360 degrees at the cable entry of the motor terminal box.

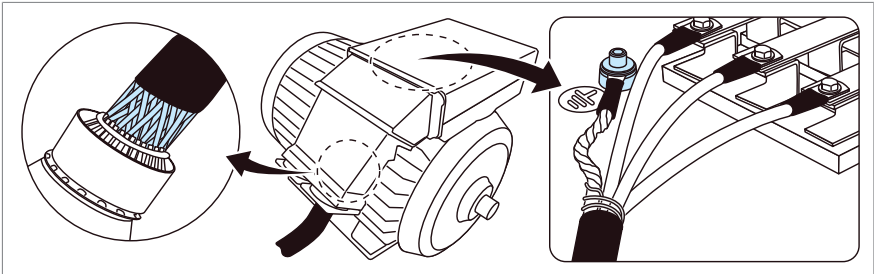

■ **Connection procedure, frame R5**

- Remove the module cover: Loosen the retaining screws with a T20 Torx screwdriver (1a) and lift the cover from the bottom outwards (1b) and then up (1c).

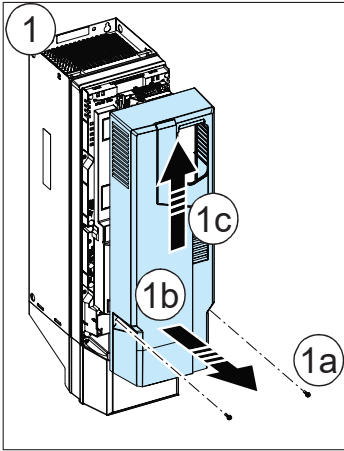

IP20

**WARNING!**

If you install the drive on any other system than symmetrically grounded TN-S system, see [Grounding system compatibility check \(page 91\)](#) if you have to disconnect the EMC filter and ground-to-phase varistor.

2. Attach the residual voltage warning sticker in the local language next to the control unit.
3. Remove the shroud on the power cable terminals by releasing the clips with a screwdriver (3a) and pulling the shroud out (3b).

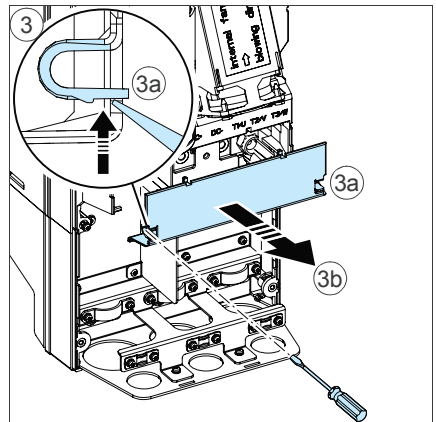
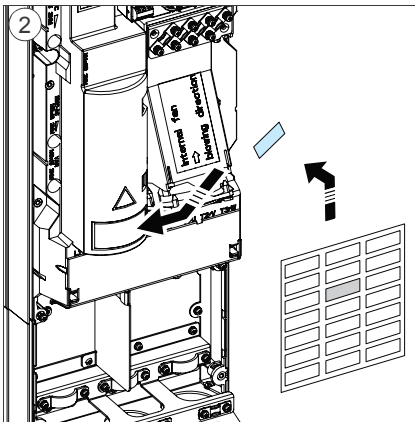

Note: Drive with cable box is used as an example in the figure. Cable box is optional and need to be ordered separately.

**Motor cable**

Use symmetrical shielded cable for motor cabling. If the cable shield is the sole PE conductor for drive or motor, make sure that it has sufficient conductivity for the PE.

4. Prepare the ends of the motor cable as illustrated in figures 5a and 5b (two different motor cable types are shown). If you use aluminum cables, put grease to the peeled aluminum cable before connecting it to the drive.

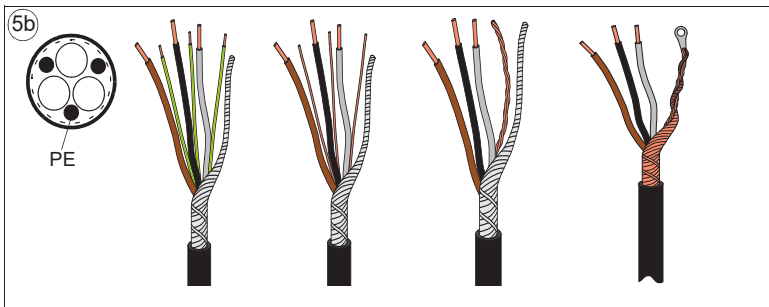
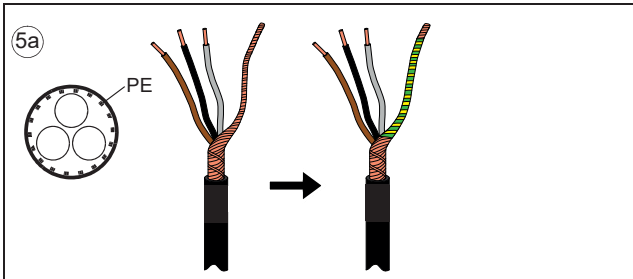

**Note:** The bare shield will be grounded 360 degrees. Mark the pigtail made from the shield as a PE conductor with yellow-and-green color.



5. Connect the motor cable:
  - Ground the shield 360 degrees by tightening the clamp of the power cable grounding shelf onto the stripped part of the cable (7a).
  - Connect the twisted shield of the cable to the grounding terminal (7b).
  - Connect the phase conductors of the cable to the T1/U, T2/V and T3/W terminals (7c). Tighten the screws to the torque given in the table.

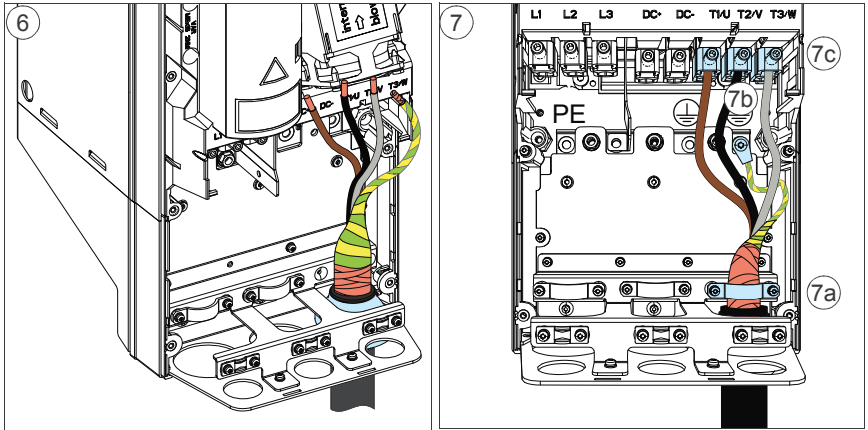



Frame size	T1/U, T2/V, T3/W	PE, 		
	N-m	M	N-m	N-m
R5	5.6	M5	2.2	1.2

Note: Drive with cable box is used as an example in the figure. Cable box is optional and need to be ordered separately.

### Input power cable

- Repeat steps 4...6 for the input power cable.



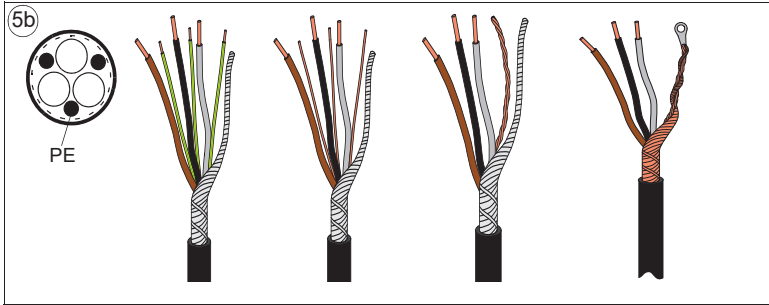
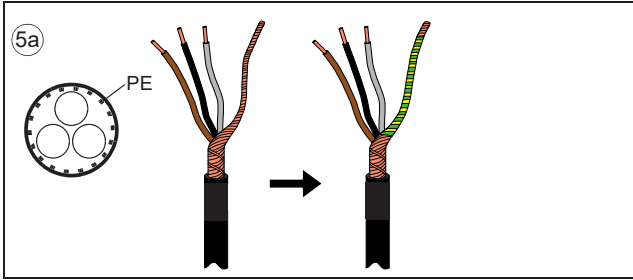

7. Connect the input power cable. Use terminals L1, L2 and L3. Tighten the screws to the torque given in the table.

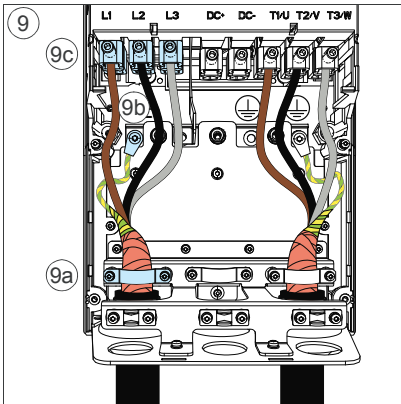

Frame size	L1, L2, L3	PE, $\oplus$		
	N-m	M	N-m	N-m
R5	5.6	M5	2.2	1.2

Note: Drive with cable box is used as an example in the figure. Cable box is optional and need to be ordered separately.

8. Reinstall the shroud on the power terminals by putting the tabs at the top of the shroud in their counterparts on the drive frame (11a) and then pressing the shroud in place (11b).

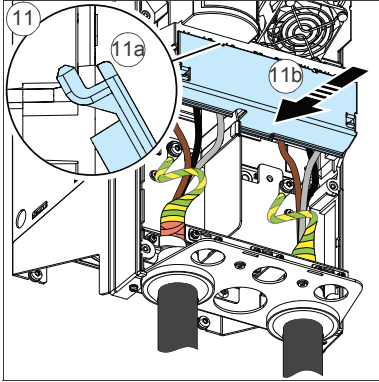

Note: Drive with cable box is used as an example in the figure. Cable box is optional and need to be ordered separately.

### Finalization

9. Secure the cables outside the unit mechanically.
10. Ground the motor cable shield at the motor end. For minimum radio frequency interference, ground the motor cable shield 360 degrees at the cable entry of the motor terminal box.

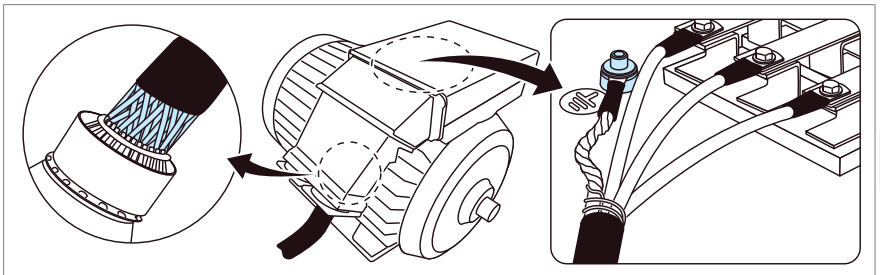

## ■ Connection procedure, frames R6...R9

**⚡ WARNING!**  
If you install the drive on any other system than symmetrically grounded TN-S system, see [Grounding system compatibility check \(page 91\)](#) if you have to disconnect the EMC filter and ground-to-phase varistor.

1. Attach the residual voltage warning sticker in the local language next to the control unit.

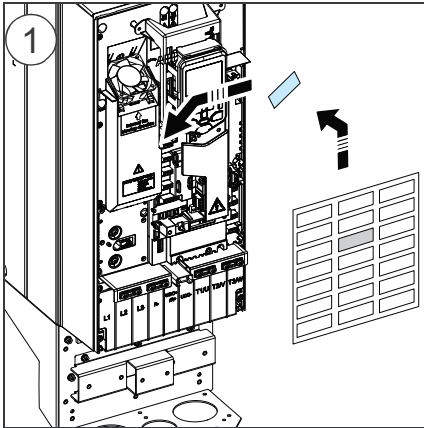

Note: Drive with cable box is used as an example in the figure. Cable box is optional and need to be ordered separately.

2. Remove the shroud on the power cable terminals by releasing the clips with a screwdriver (3a) and pulling the shroud out (3b).
3. Knock out holes in the shroud for the cables to be installed.
4. Prepare the ends of the input power cable and motor cable as illustrated in the figure. If you use aluminum cables, put grease to the peeled aluminum cable before connecting it to the drive. Two different motor cable types are shown in the figures (7a, 7b).

**Note:** The bare shield will be grounded 360 degrees. Mark the pigtail made from the shield as a PE conductor with yellow-and-green color.

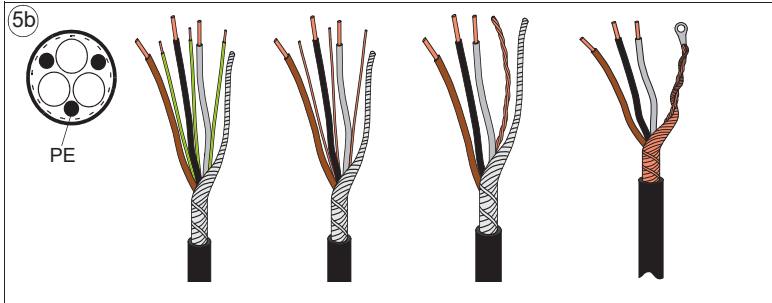
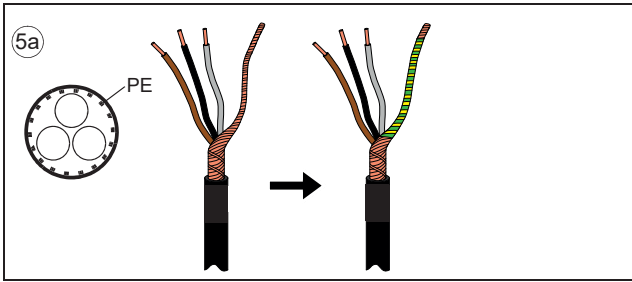



5. Connect the motor cable:

- Ground the shield 360 degrees under the grounding clamps.
- Connect the twisted shield of the cable to the grounding terminal (9a).
- Connect the phase conductors of the cable to terminals T1/U, T2/V and T3/W. Tighten the screws to the torque given in the table (9b).

**Input power cable**

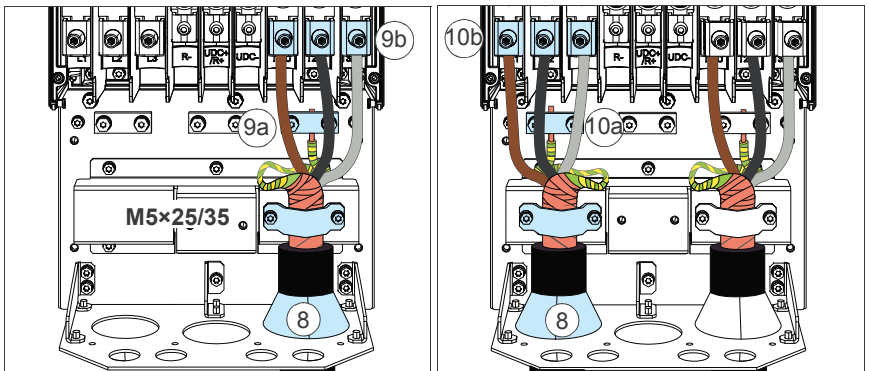
6. Connect the input power cable as in step 9. Use terminals L1, L2, L3.



Frame size	L1, L2, L3, T1/U, T2/V, T3/W	PE, 	
	N·m	N·m	N·m
<b>R6</b>	30	9.8	1.2
<b>R7</b>	40	9.8	1.2
<b>R8</b>	40	9.8	1.2
<b>R9</b>	70	9.8	1.2

Note: Drive with cable box is used as an example in the figure. Cable box is optional and need to be ordered separately.

**Detaching and reinstalling the connectors**

This is possible but not recommended.

Terminals T1/U, T2/V and T3/W

- Remove the nut that attaches the connector to its busbar.
- Put the conductor under the connector pressure plate and pre-tighten the conductor.
- Put the connector back to its busbar. Start the nut, and turn it at least two rotations by hand.



**WARNING!**

Before you use tools, make sure that the nut or screw is not cross-threading. Cross-threading can damage the drive and cause danger.

- Tighten the nut to a torque of 30 N·m .

Terminals L1, L2 and L3

- Remove the combi screw that attaches the connector to its terminal post, and pull the connector off.
- Put the conductor under the connector pressure plate and pre-tighten the conductor.
- Put the connector back onto the terminal post. Start the combi screw, and turn it at least two rotations by hand.



**WARNING!**

Before you use tools, make sure that the nut or screw is not cross-threading. Cross-threading can damage the drive and cause danger.

- Tighten the combi screw to a torque of 30 N·m .

7. Install the grounding shelf of the control cables.
8. Reinstall the shroud on the power terminals.
9. Secure the cables outside the unit mechanically.



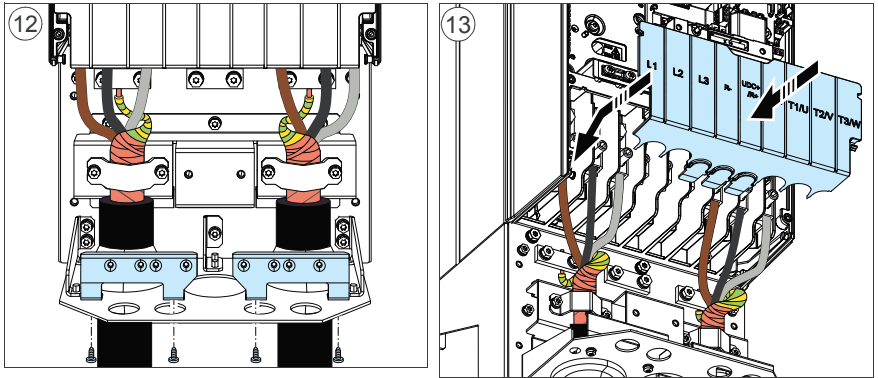

Note: Drive with cable box is used as an example in the figure. Cable box is optional and need to be ordered separately.

- Ground the motor cable shield at the motor end. For minimum radio frequency interference, ground the motor cable shield 360 degrees at the cable entry of the motor terminal box.

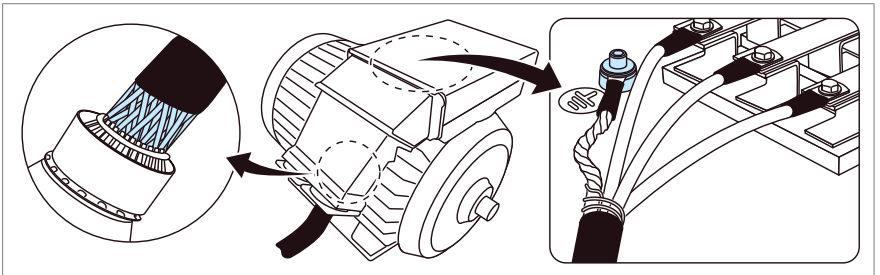

## DC connection

The UDC+ and UDC- terminals (as standard in frames R4...R9) are for using external brake chopper units.



## Connecting the control cables

### ■ Connection diagram

See [Default I/O connection diagram](#) for the default I/O connections of the drive.

### ■ Control cable connection procedure R1...R9

---



#### **WARNING!**

Obey the safety instructions of the drive. If you ignore them, injury or death, or damage to the equipment can occur.

---

1. Do the steps in section [Electrical safety precautions \(page 20\)](#) before you start the work.

2. Remove the front cover(s) if not already removed. See page [100\(R1...R4\)](#), page [106\(R5\)](#) or page [112\(R6...R9\)](#).

#### Analog signals

The figures for frames R1...R2 and R3 (page [118](#), R4 (page [119](#)), R5 (page [120](#)) and R6...R9 (page [121](#)) show an example of connecting a cable. Make the connections according to the macro in use. Make the connections according to the default configuration.

3. If you have ordered optional conduit box, cut an adequate hole into the rubber grommet and slide the grommet onto the cable. Slide the cable through a hole in the cable entry and attach the grommet to the hole.

4. Ground the outer shield of the cable 360 degrees under the grounding clamp. Keep the cable unstripped as close to the terminals of the control unit as possible.

Frames R5...R9: Secure the cables mechanically at the clamps below the control unit.

Ground also the pair-cable shields and grounding wire at the SCR terminal.

5. Route the cable as shown in the figures for frames R1...R2 and R3 (page [118](#), R4 (page [119](#)), R5 (page [120](#)) and R6...R9 (page [121](#)).

6. Connect the conductors to the appropriate terminals of the control unit and tighten to 0.5...0.6 N·m .

#### Digital signals

The figures for frames R1...R2 and R3 (page [118](#), R4 (page [119](#)), R5 (page [120](#)) and R6...R9 (page [121](#)) show an example of connecting a cable. Make the connections according to the macro in use.

7. Cut an adequate hole into the rubber grommet and slide the grommet onto the cable. Slide the cable through the hole in the cable entry and attach the grommet to the hole.
- 



8. Ground the outer shield of the cable 360 degrees under the grounding clamp. Keep the cable unstripped as close to the terminals of the control unit as possible.  
Frames R5...R9: Secure the cables mechanically at the clamps below the control unit.  
If you use double-shielded cables, ground also the pair-cable shields and grounding wire at the SCR terminal.
9. Route the cable as shown in the figures for frames R1...R2 and R3 (page 118, R4 (page 119), R5 (page 120) and R6...R9 (page 121).
10. Connect the conductors to the appropriate terminals of the control unit and tighten to 0.5...0.6 N·m .
11. Tie all control cables to the provided cable tie mounts.

**Note:**

- Leave the other ends of the control cable shields unconnected or ground them indirectly via a high-frequency capacitor with a few nanofarads, eg, 3.3 nF / 630 V. The shield can also be grounded directly at both ends if they are in the same ground line with no significant voltage drop between the end points.
- Keep any signal wire pairs twisted as close to the terminals as possible. Twisting the wire with its return wire reduces disturbances caused by inductive coupling.



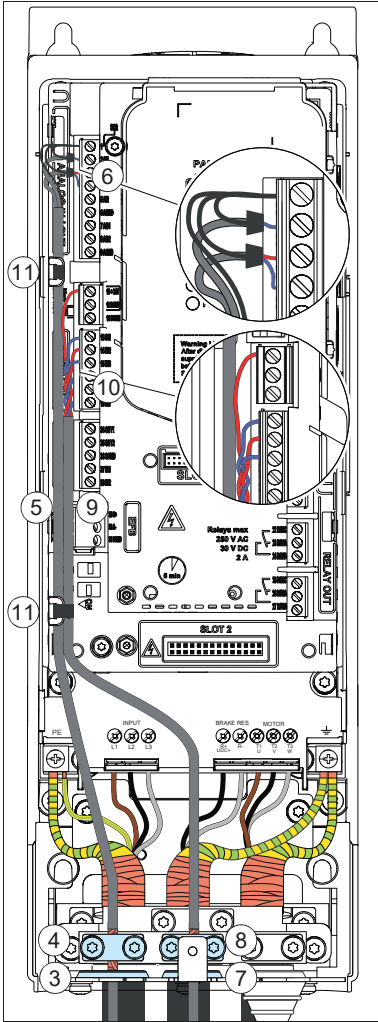

R1...R2: 0.5...0.6 N·m

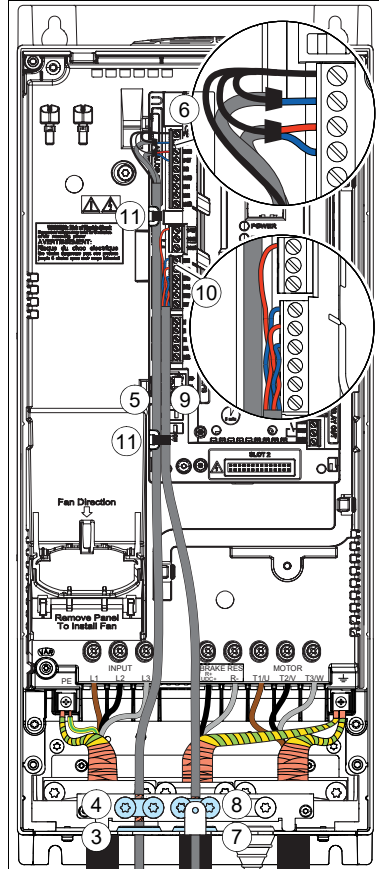

R3: 0.5...0.6 N·m



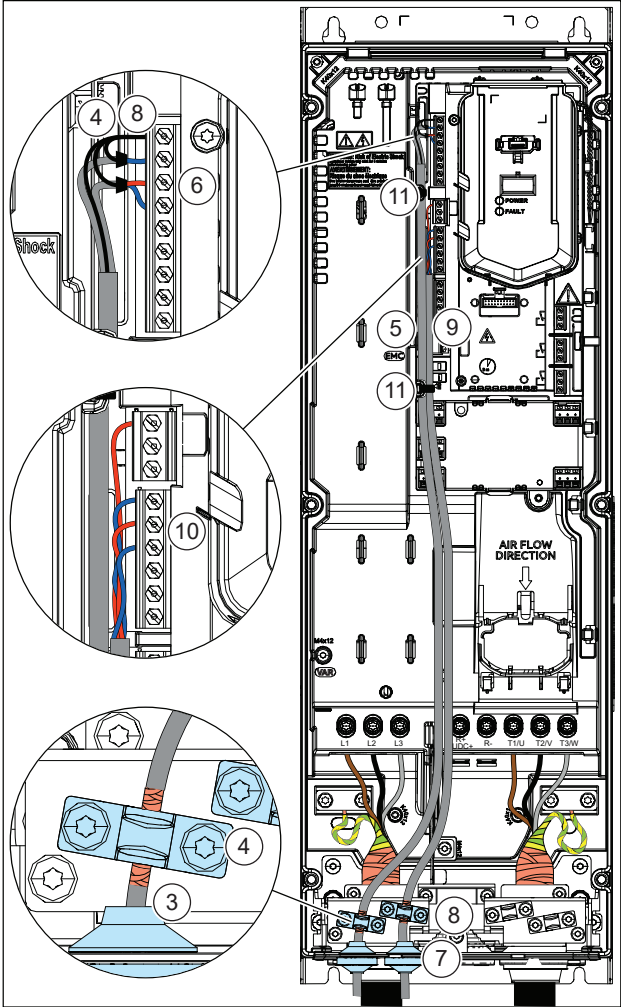

R4

R5

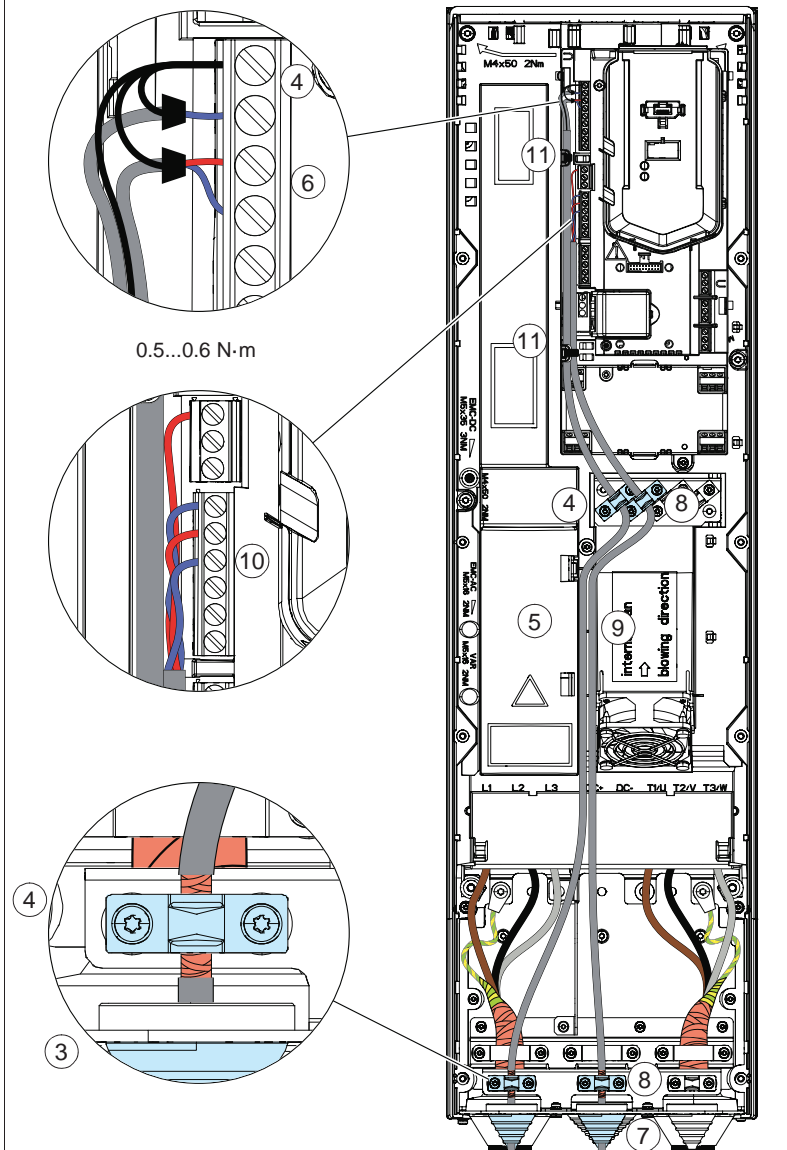

R6...R9

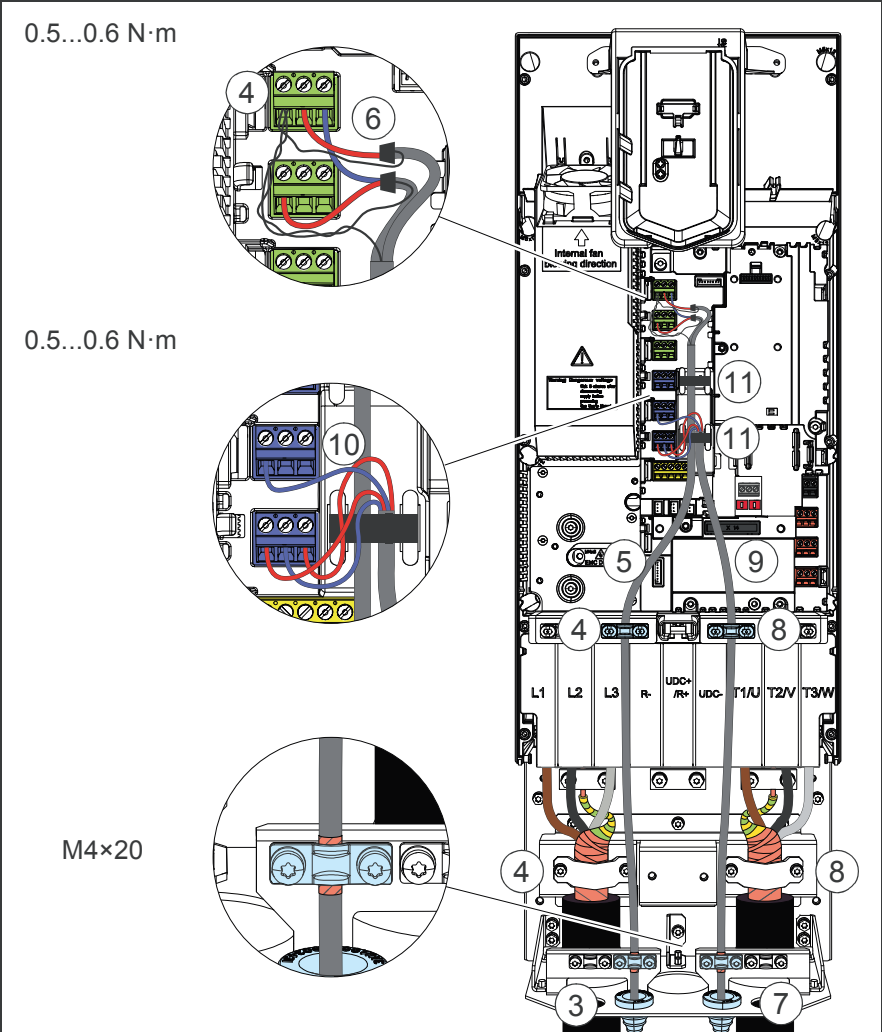

Note: Drive with cable box is used as an example in the figures. Cable box is optional and need to be ordered separately.

## Installing option modules



### WARNING!

Obey the safety instructions of the drive. If you ignore them, injury or death, or damage to the equipment can occur.

1. Stop the drive and do the steps in section [Electrical safety precautions](#) (page 20) before you start the work.

### ■ Option slot 2 (I/O extension modules)

1. Put the module carefully into its position on the control unit.
2. Tighten the mounting screw.
3. Tighten the grounding screw (CHASSIS) to 0.8 N·m. The screw grounds the module. It is necessary for fulfilling the EMC requirements and for correct operation of the module.

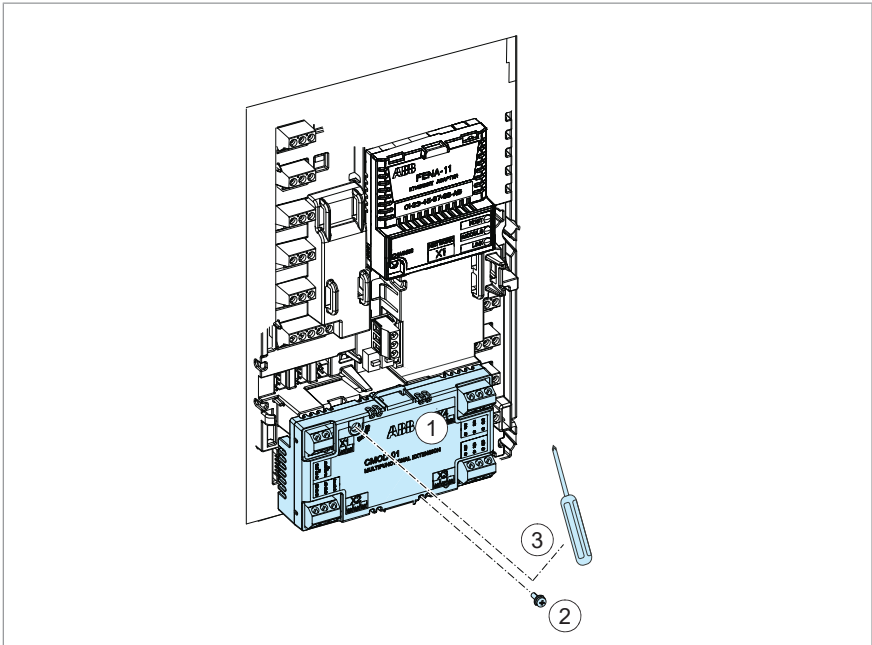

### ■ Option slot 1 (fieldbus adapter modules)

1. Put the module carefully into its position on the control unit.
2. Tighten the mounting screw (CHASSIS) to 0.8 N·m. The screw tightens the connections and grounds the module. It is necessary for fulfilling the EMC requirements and for correct operation of the module.

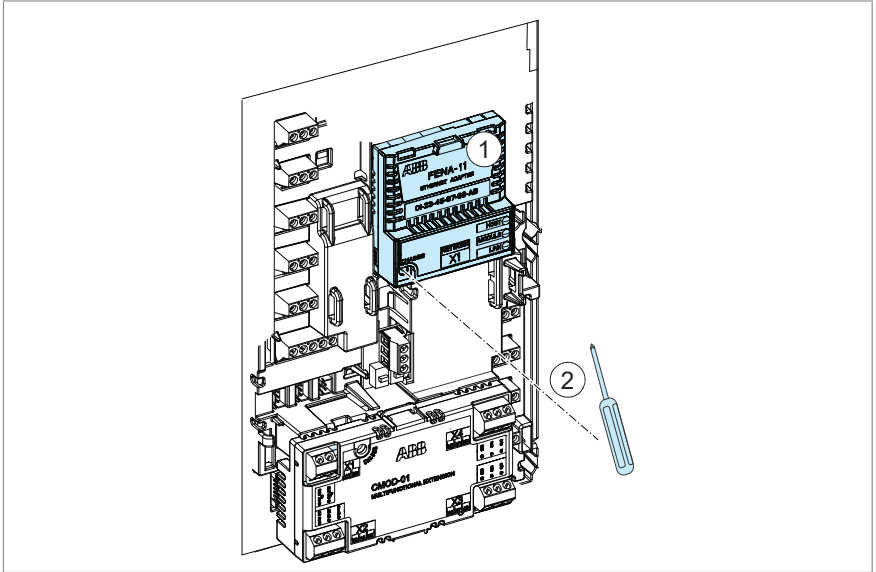

### ■ Wiring the optional modules

See the appropriate option module manual or for I/O options the appropriate chapter in this manual.



## Reinstalling covers

### ■ Reinstalling cover, frames R1...R4

1. Reinstall the cover: Put the tabs on the cover top in their counterparts on the housing (1a) and then press the cover (1b).
2. Tighten the retaining screw at the bottom with a T20 Torx screwdriver.

IP20 R1...R2

IP20 R3...R4

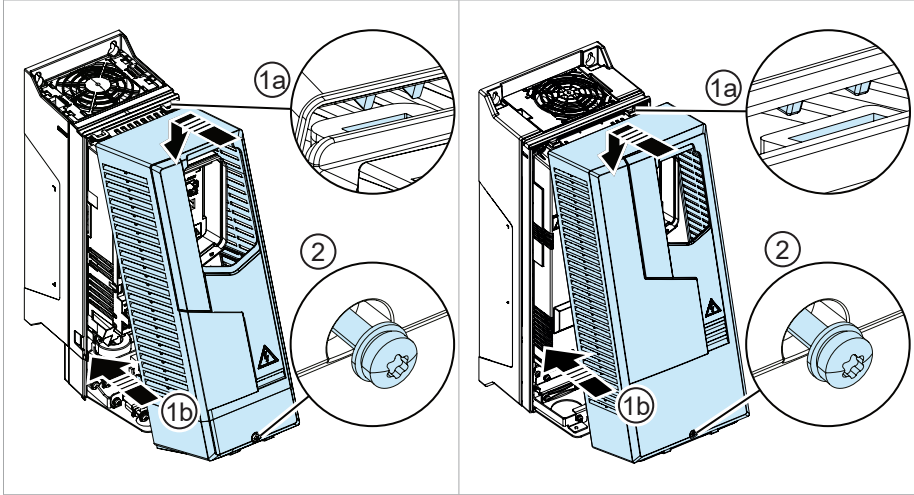

### ■ Reinstalling covers, frame R5...R9

Reinstall the module cover: Press the cover at the bottom (2a) and tighten the retaining screws (2b).



IP20

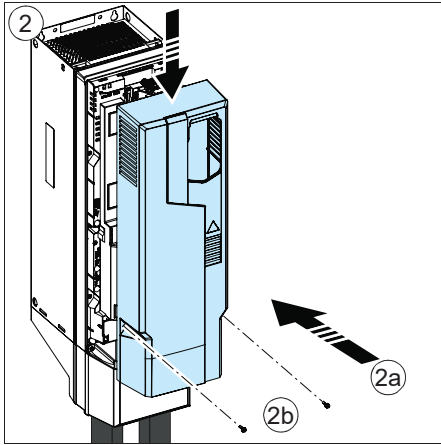

## Connecting a PC



### WARNING!

Do not connect the PC directly to the control panel connector of the control unit. It can cause damage.



A PC (with eg, the Drive composer PC tool) can be connected with assistant control panel:

1. Connect an ACS-AP-x control panel to the unit either
  - by inserting the control panel into the panel holder or platform, or
  - by using an Ethernet (eg, Cat 5e) networking cable.
2. Remove the USB connector cover on the front of the control panel.
3. Connect an USB cable (Type A to Type Mini-B) between the USB connector on the control panel (3a) and a free USB port on the PC (3b).
4. The panel will display an indication whenever the connection is active.
5. See the documentation of the PC tool for setup instructions.

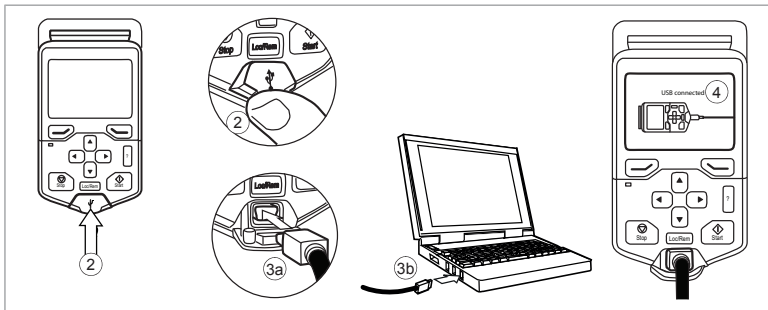

## Connecting a remote panel, or chaining one panel to several drives

You can connect a drive control panel remotely to the drive, or chain the control panel or a PC to several drives on a panel bus with a CDPI-01 communication adapter module. See [CDPI-01 communication adapter module user's manual \(3AXD5000009929 \[English\]\)](#).





# Control unit

---

## Contents of this chapter

This chapter contains the default I/O connection diagram, descriptions of the terminals and technical data for the drive control unit (CCU-23 and CCU-24).

---

## Layout

The layout of the external control connection terminals on the drive module control unit is shown below.

### ■ CCU-23 (R1...R5)

SLOT 1	
Option slot 1 (fieldbus adapter modules)	
ANALOG IN/OUT	
1...3	Analog input 1
4...6	Analog input 2
7...9	Analog outputs
10...12	Auxiliary voltage output, digital input common
DIGITAL IN	
13...18	Digital inputs
STO	
34...38	Safe torque off connection.
X12	Panel port (control panel connection, wired at the factory to the control panel)
EFB	
EIA/RS-485 fieldbus connector	
BIAS	Bias resistor switch
TERM	End termination switch
29...31	Connection terminals
SLOT 2	
Option slot 2 (I/O extension modules)	
RO1 ... RO3	
19...21	Relay output 1 (RO1)
22...24	Relay output 2 (RO2)
25...27	Relay output 3 (RO3)

■ **CCU-24 (R6...R9)**

# 130 Control unit

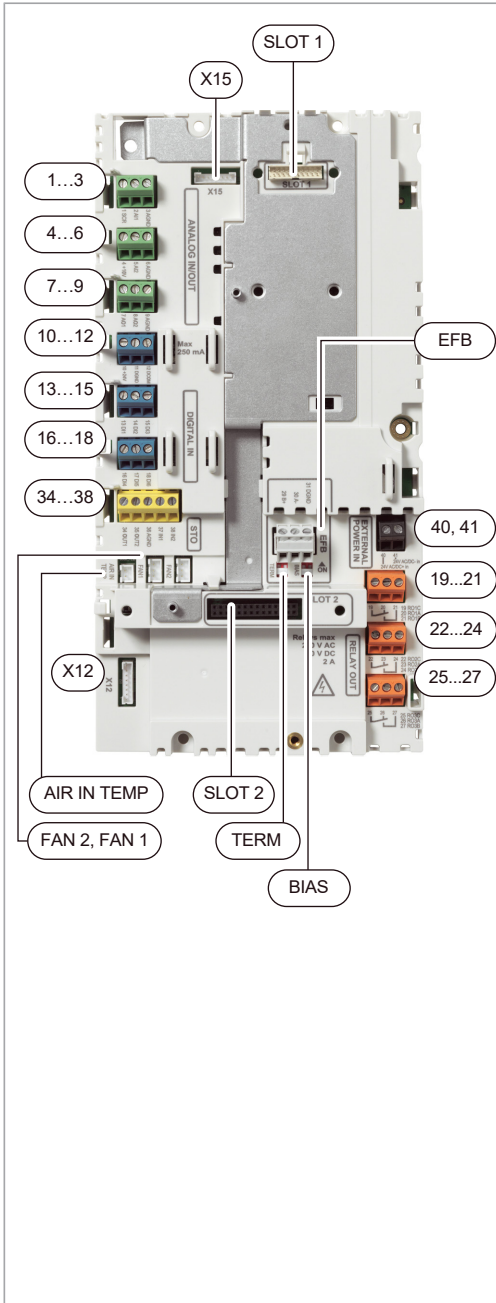

<b>SLOT 1</b>	
Option slot 1 (fieldbus adapter modules)	
<b>ANALOG IN/OUT</b>	
1...3	Analog input 1
4...6	Analog input 2
7...9	Analog outputs
10...12	Auxiliary voltage output, digital input common
<b>DIGITAL IN</b>	
13...18	Digital inputs
<b>STO</b>	
34...38	Safe torque off connection.
40, 41	AIR IN TEMP Internal air temperature NTC sensor connection
19...21	FAN2 Internal fan 2 connection
22..24	FAN1 Internal fan 1 connection
X12	Panel port (control panel connection, wired at the factory to the control panel)
X15	Reserved to internal use.
<b>EFB</b>	
EIA/RS-485 fieldbus connector	
BIAS	Bias resistor switch
TERM	End termination switch
29...31	Connection terminals
<b>SLOT 2</b>	
Option slot 2 (I/O extension modules)	
40, 41	24 V AC/DC external power input
<b>RO1 ... RO3</b>	
19...21	Relay output 1 (RO1)
22...24	Relay output 2 (RO2)
25...27	Relay output 3 (RO3)

## Default I/O connection diagram

### ■ Default I/O connection diagram

The default I/O connections of the ABB Standard macro are shown below.

CCU-23 (R1...R5)

Connection	Term	Description	
<b>X1 Reference voltage and analog inputs and outputs</b>			
	1	SCR	Signal cable shield (screen)
	2	AI1	Output frequency reference: 0...10 V <sup>1) 3)</sup>
	3	AGND	Analog input circuit common
	4	+10V	Reference voltage 10 V DC
	5	AI2	Not configured
	6	AGND	Analog input circuit common
	7	AO1	Output frequency: 0...20 mA
	8	AO2	Motor current: 0...20 mA
	9	AGND	Analog output circuit common
<b>X2 &amp; X3 Aux. voltage output and programmable digital inputs</b>			
	10	+24V	Aux. voltage output +24 V DC, max. 250 mA <sup>2)</sup>
	11	DGND	Aux. voltage output common
	12	DCOM	Digital input common for all
	13	DI1	Stop (0) / Start (1)
	14	DI2	Forward (0) / Reverse (1)
	15	DI3	Constant frequency selection <sup>4)</sup>
	16	DI4	Constant frequency selection <sup>4)</sup>
	17	DI5	Ramp set 1 (0) / Ramp set 2 (1) <sup>5)</sup>
	18	DI6	Not configured
<b>X5 EIA-485 Modbus RTU</b>			

132 Control unit

Connection		Term	Description					
<table border="1"> <tr><td>29</td></tr> <tr><td>30</td></tr> <tr><td>31</td></tr> <tr><td>S4</td></tr> <tr><td>S5</td></tr> </table>	29	30	31	S4	S5	29	B+	Embedded Modbus RTU (EIA-485)
	29							
	30							
	31							
	S4							
S5								
30	A-							
31	DGND							
S4	TERM	Serial data link termination switch						
S5	BIAS	Serial data link termination switch						
<b>X6, X7, X8 Relay outputs</b>								
	19	RO1C	Ready run					
	20	RO1A	250 V AC / 30 V DC 2 A					
	21	RO1B						
	22	RO2C	Running					
	23	RO2A	250 V AC / 30 V DC 2 A					
	24	RO2B						
	25	RO3C	Fault (-1)					
	26	RO3A	250 V AC / 30 V DC 2 A					
	27	RO3B						
<b>X4 Safe Torque Off</b>								
	34	OUT1	Safe torque off. Factory connection. Both circuits must be closed for the drive to start. Refer to <a href="#">Safe torque off function</a> .  <b>X4 Safe Torque Off</b>					
	35	OUT2						
	36	SGND						
	37	IN1						
	38	IN2						

Total load capacity of the Auxiliary voltage output +24V (X2:10) is 6.0 W (250 mA / 24 V DC).

Digital inputs DI1...DI5 also support 10...24 V AC.

Terminal sizes: 0.2 ... 2.5 mm<sup>2</sup> (24...14 AWG) (Terminals +24V, DGND, DCOM, B+, A-, DGND, Ext. 24V)

Terminal sizes: 0.14 ... 1.5 mm<sup>2</sup> (26...16 AWG) (Terminals DI, AI, AO, AGND, RO, STO)

Tightening torques: 0.5 ... 0.6 N·m

Wire strip length 7...8 mm

## CCU-24 (R6...R9)

Connection	Term	Description	
<b>X1 Reference voltage and analog inputs and outputs</b>			
<p>1...10 kohm</p> <p>Max. 500 ohm</p> <p>8)</p>	1	SCR	Signal cable shield (screen)
	2	AI1	Output frequency reference: 0...10 V <sup>1) 3)</sup> Output frequency/speed reference: 0...10 V <sup>1)</sup>
	3	AGND	Analog input circuit common
	4	+10V	Reference voltage 10 V DC
	5	AI2	Not configured
	6	AGND	Analog input circuit common
	7	AO1	Output frequency: 0...20 mA
	8	AO2	Motor current: 0...20 mA
	9	AGND	Analog output circuit common
<b>X2 &amp; X3 Aux. voltage output and programmable digital inputs</b>			
<p>6)</p> <p>7)</p>	10	+24V	Aux. voltage output +24 V DC, max. 250 mA <sup>2)</sup>
	11	DGND	Aux. voltage output common
	12	DCOM	Digital input common for all
	13	DI1	Stop (0) / Start (1)
	14	DI2	Forward (0) / Reverse (1)
	15	DI3	Constant frequency selection <sup>4)</sup>
	16	DI4	Constant frequency selection <sup>4)</sup>
	17	DI5	Ramp set 1 (0) / Ramp set 2 (1) <sup>5)</sup>
	18	DI6	Not configured
<b>X6, X7, X8 Relay outputs</b>			

## 134 Control unit

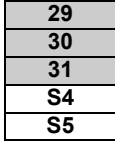
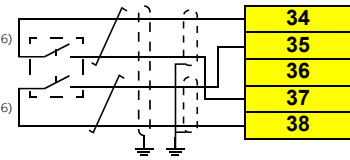
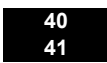
Connection		Term	Description	
Ready run status	← 19	19 RO1C	Ready run	
	← 20	20 RO1A	250 V AC / 30 V DC	
	← 21	21 RO1B	2 A	
Run status	← 22	22 RO2C	Running	
	← 23	23 RO2A	250 V AC / 30 V DC	
	← 24	24 RO2B	2 A	
Fault status	← 25	25 RO3C	Fault (-1)	
	← 26	26 RO3A	250 V AC / 30 V DC	
	← 27	27 RO3B	2 A	
	<b>X5 EIA-485 Modbus RTU</b>			
		29	B+	Embedded Modbus RTU (EIA-485)
30		A-		
31		DGND		
S4		TERM	Serial data link termination switch	
S5		BIAS	Serial data link bias resistors switch	
<b>X4 Safe Torque Off</b>				
	34	OUT1	Safe torque off. Factory connection. Both circuits must be closed for the drive to start. Refer to <a href="#">Safe torque off function</a> .	
	35	OUT2		
	36	SGND		
	37	IN1		
	38	IN2		
<b>X10 24 V AC/DC</b>				
	40	24 V AC/DC+ in	External 24 V AC/DC input to power up the control unit when the main supply is disconnected. <sup>9)</sup>	
	41	24 V AC/DC- in		

Total load capacity of the Auxiliary voltage output +24V (X2:10) is 6.0 W (250 mA / 24 V DC).

Digital inputs DI1...DI5 also support 10...24 V AC.

Terminal sizes (all terminals): 0.14 ... 2.5 mm<sup>2</sup> (26...14 AWG)

Tightening torques: 0.5 ... 0.6 N·m

Wire strip length 7...8 mm

**Notes:**

- 1) Current [0(4)...20 mA,  $R_{in} = 100 \text{ ohm}$ ] or voltage [0(2)...10 V,  $R_{in} > 200 \text{ kohm}$ ]. Change of setting requires changing the corresponding parameter.
- 2) Total load capacity of the Auxiliary voltage output +24V (X2:10) is 6.0 W (250 mA / 24 V) minus the power taken by the option modules installed on the board.
- 3) AI1 is used as a speed reference if vector control is selected.
- 4) In scalar control (default): See **Menu > Primary settings > Start, stop, reference > Constant frequencies** or parameter group 28 Frequency reference chain.

DI3	DI4	Operation/Parameter
0	0	Set frequency through AI1
1	0	28.26 Constant frequency 1
0	1	28.27 Constant frequency 2
1	1	28.28 Constant frequency 3

- 5) In scalar control (default): See **Menu - Primary settings - Ramps** or parameter group 28 Frequency reference chain.

DI5	Ramp set	Parameters
0	1	28.72 Freq acceleration time 1 28.73 Freq deceleration time 1
1	2	28.74 Freq acceleration time 2 28.75 Freq deceleration time 2

- 6) Connected with jumpers at the factory.
- 7) Use shielded twisted-pair cables for digital signals.
- 8) Ground the outer shield of the cable 360° under the grounding clamp on the grounding shelf, and the pair-cable shields and grounding wire at the grounding terminal (SCR) of the control unit.
- 9)  **WARNING!** Connect an external AC power supply (24 V AC) only to control unit connectors 40 and 41. If you connect it to connector AGND, DGND or SGND, damage to the power supply or control unit can occur.

## Additional information on I/O connections

### ■ Embedded EIA-485 fieldbus connection

The EIA-485 network uses shielded, twisted-pair cable with a characteristic impedance of 100...130 ohm for data signaling. The distributed capacitance between conductors is less than 100 pF per meter. Distributed capacitance between conductors and shield is less than 200 pF per meter. Foil or braided shields are acceptable.

Connect the cable to the EIA-485 terminal on the control unit. Obey these wiring instructions:

- Attach the cable shields together at each drive, but do not connect them to the drive.
  - Connect the cable shields only to the grounding terminal in the automation controller.
  - Connect the signal ground (DGND) conductor to the signal ground reference terminal in the automation controller. If the automation controller does not have a signal ground reference terminal, connect the signal ground conductor to the cable shield through a 100 ohm resistor, preferably near the automation controller.
-

Connection examples are shown below.

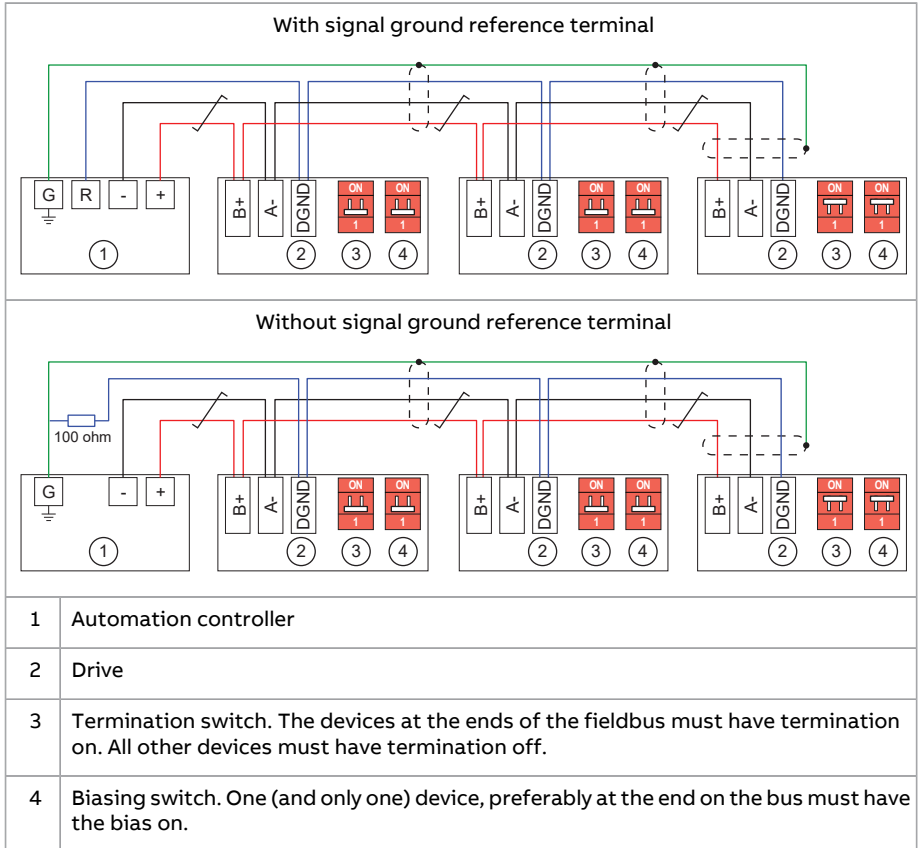

### ■ Connecting motor temperature sensors to the drive

IEC/EN 60664 requires double or reinforced insulation between the control unit and the live parts of the motor. To achieve this, use an CMOD-02 I/O extension module. Refer to section [Implementing a motor temperature sensor connection](#) and chapter [CMOD-02 multifunction extension module \(external 24 V AC/DC and isolated PTC interface\)](#).

■ PNP configuration for digital inputs (DIGITAL IN)

<p style="text-align: center;"><b>Internal 24 V voltage source</b></p> <table border="1" style="margin-left: auto; margin-right: auto; border-collapse: collapse;"> <tr><td>10</td><td>+24 V</td></tr> <tr><td>11</td><td>DGND</td></tr> <tr><td>12</td><td>DCOM</td></tr> <tr><td>13</td><td>DI1</td></tr> <tr><td>14</td><td>DI2</td></tr> <tr><td>15</td><td>DI3</td></tr> <tr><td>16</td><td>DI4</td></tr> <tr><td>17</td><td>DI5</td></tr> <tr><td>18</td><td>DI6</td></tr> </table>	10	+24 V	11	DGND	12	DCOM	13	DI1	14	DI2	15	DI3	16	DI4	17	DI5	18	DI6	<p style="text-align: center;"><b>External 24 V DC voltage source</b></p> <table border="1" style="margin-left: auto; margin-right: auto; border-collapse: collapse;"> <tr><td>10</td><td>+24 V</td></tr> <tr><td>11</td><td>DGND</td></tr> <tr><td>12</td><td>DCOM</td></tr> <tr><td>13</td><td>DI1</td></tr> <tr><td>14</td><td>DI2</td></tr> <tr><td>15</td><td>DI3</td></tr> <tr><td>16</td><td>DI4</td></tr> <tr><td>17</td><td>DI5</td></tr> <tr><td>18</td><td>DI6</td></tr> </table>	10	+24 V	11	DGND	12	DCOM	13	DI1	14	DI2	15	DI3	16	DI4	17	DI5	18	DI6
10	+24 V																																				
11	DGND																																				
12	DCOM																																				
13	DI1																																				
14	DI2																																				
15	DI3																																				
16	DI4																																				
17	DI5																																				
18	DI6																																				
10	+24 V																																				
11	DGND																																				
12	DCOM																																				
13	DI1																																				
14	DI2																																				
15	DI3																																				
16	DI4																																				
17	DI5																																				
18	DI6																																				
<p style="text-align: center;"><b>External 24 V AC voltage source</b></p> <table border="1" style="margin-left: auto; margin-right: auto; border-collapse: collapse;"> <tr><td>10</td><td>+24 V</td></tr> <tr><td>11</td><td>DGND</td></tr> <tr><td>12</td><td>DCOM</td></tr> <tr><td>13</td><td>DI1</td></tr> <tr><td>14</td><td>DI2</td></tr> <tr><td>15</td><td>DI3</td></tr> <tr><td>16</td><td>DI4</td></tr> <tr><td>17</td><td>DI5</td></tr> <tr><td>18</td><td>DI6</td></tr> </table> <p><b>Note:</b> DI6 is not supported with external 24 V AC voltage source.</p>		10	+24 V	11	DGND	12	DCOM	13	DI1	14	DI2	15	DI3	16	DI4	17	DI5	18	DI6																		
10	+24 V																																				
11	DGND																																				
12	DCOM																																				
13	DI1																																				
14	DI2																																				
15	DI3																																				
16	DI4																																				
17	DI5																																				
18	DI6																																				
<div style="display: flex; align-items: flex-start;"> <div style="margin-right: 20px;"> <p><b>WARNING!</b></p> <p><b>CCU-23:</b> If you connect external 24 V AC voltage source via CMOD-01 or CMOD-02 to control unit, do not connect 24 V AC to terminal block DIGITAL IN. It can cause damage to the control unit.</p> <p><b>CCU-24:</b> If you connect external 24 V AC voltage source to terminal block EXTERNAL POWER IN (terminals 40 and 41), do not connect 24 V AC to terminal block DIGITAL IN. It can cause damage to the control unit.</p> </div> </div>																																					

## ■ NPN configuration for digital inputs (DIGITAL IN)

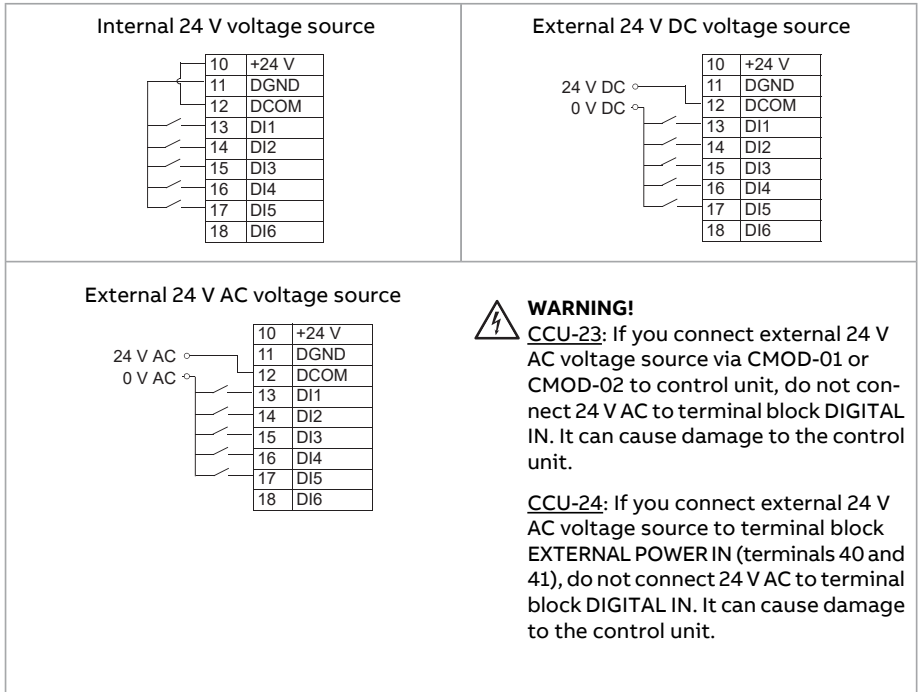

**Note:** DI6 is not supported in the NPN configuration.

## ■ Connection for obtaining 0...10 V from analog output 2 (AO2)

To obtain 0...10 V from analog output AO2, connect a 500 ohm resistor (or two 1 kohm resistors in parallel) between analog output AO2 and analog common ground AGND.

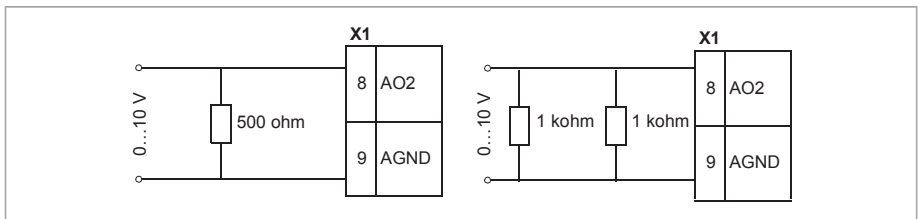

■ **Connection examples of two-wire and three-wire sensors to analog input (AI2)**

**Note:** The maximum capability of the auxiliary voltage output (24 V DC [250 mA]) must not be exceeded.

An example of a two-wire sensor/transmitter supplied by the drive auxiliary voltage output is shown below. Set the input signal to 4...20 mA, not 0...20 mA.

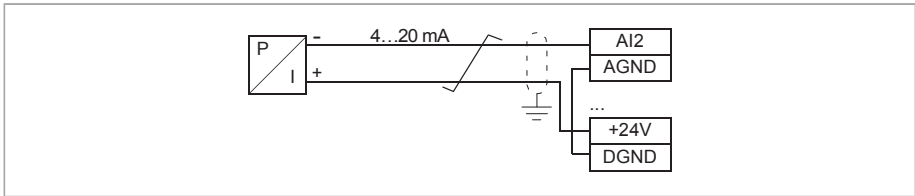

An example of a three-wire sensor/transmitter supplied by the drive auxiliary voltage output is shown below. The sensor is supplied through its current output and the drive feeds the supply voltage (+24 V DC). Thus the output signal must be 4...20 mA, not 0...20 mA.

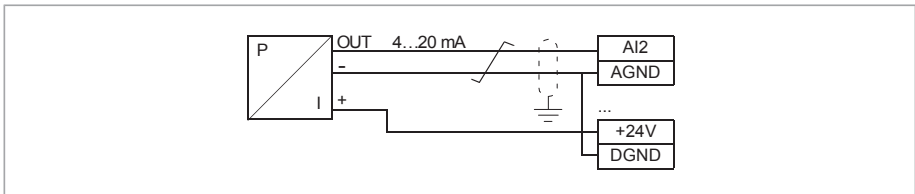

■ **DI5 as frequency input**

For setting the parameters for the digital frequency input, see the firmware manual.

■ **Safe torque off (X4)**

For the drive to start, both connections (+24 V DC to IN1 and +24 V DC to IN2) must be closed. By default, the terminal block has jumpers to close the circuit.

Remove the jumpers before connecting an external Safe torque off circuitry to the drive. See also chapter [The Safe torque off function \(page 219\)](#).

**Note:** Only 24 V DC can be used for STO. Only PNP input configuration can be used.

## Technical data

### CCU-23 (R1...R5)

External power supply through option module CMOD-01 or CMOD-02	Maximum power: 25 W, 1.04 A at 24 V AC/DC $\pm 10\%$ as standard Terminal size: 0.2 ... 2.5 mm <sup>2</sup> (24 ... 14 AWG)
+24 V DC output (Term. 10)	Total load capacity of the outputs is 6.0 W (250 mA / 24 V) minus the power taken by the option modules installed on board. Terminal size: 0.2 ... 2.5 mm <sup>2</sup> (24 ... 14 AWG)
Digital inputs DI1...DI6 (Term. 13...18)	<p>Input type: NPN/PNP Terminal size: 0.14 ... 1.5 mm<sup>2</sup> (26 ... 16 AWG)</p> <p><u>DI1...DI4 (Term. 13...16)</u> 12/24 V DC logic levels: "0" &lt; 4 V, "1" &gt; 8 V <math>R_{in}</math>: 3 kohm Hardware filtering: 0.04 ms, digital filtering: 2 ms sampling</p> <p><u>DI5 (Term.17)</u> Can be used as a digital or frequency input. 12/24 V DC logic levels: "0" &lt; 4 V, "1" &gt; 8 V <math>R_{in}</math>: 3 kohm Max. frequency: 16 kHz Symmetrical signal (duty cycle D = 0.50)</p> <p><u>DI6 (Term.18)</u> Can be used as a digital or PTC input. 12/24 V DC logic levels: "0" &lt; 3 V, "1" &gt; 8 V <math>R_{in}</math>: 3 kohm Max. frequency: 16 kHz Symmetrical signal (duty cycle D = 0.50) Hardware filtering: 0.04 ms, digital filtering: 2 ms sampling</p> <p><b>Note:</b> DI6 is not supported in the NPN configuration. PTC mode – PTC thermistor can be connected between DI6 and +24 V DC: &lt; 1.5 kohm = '1' (low temperature), &gt; 4 kohm = '0' (high temperature), open circuit = '0' (high temperature). DI6 is not a reinforced/double insulated input. Connecting the motor PTC sensor to this input requires usage of a reinforced/double insulated PTC sensor inside the motor</p>
Relay outputs RO1...RO3 (Term. 19...27)	250 V AC / 30 V DC, 2 A. Terminal size: 0.14 ... 1.5 mm <sup>2</sup> (26 ... 16 AWG)  See section <a href="#">Isolation areas (page 143)</a> .

142 Control unit

<p>Analog inputs AI1 and AI2 (Term. 2 and 5)</p>	<p>Current/voltage input mode selected with a parameter, see <a href="#">Connecting motor temperature sensors to the drive (page 137)</a>.            Current input: 0(4)...20 mA, <math>R_{in}</math>: 100 ohm            Voltage input: 0(2)...10 V, <math>R_{in}</math>: &gt; 200 kohm            Terminal size: 0.14 ... 1.5 mm<sup>2</sup> (26 ... 16 AWG)            Inaccuracy: typical ±1%, max. ±1.5% of full scale            Inaccuracy for Pt100 sensors: 10 °C (50 °F)</p>
<p>Analog outputs AO1 and AO2 (Term. 7 and 8)</p>	<p>Current/voltage output mode for AO1 selected with a parameter, see <a href="#">Connection for obtaining 0...10 V from analog output 2 (AO2) (page 139)</a>.            Current output: 0...20 mA, <math>R_{load}</math>: &lt; 500 ohm            Voltage input: 0...10 V, <math>R_{load}</math>: &gt; 100 kohm (AO1 only)            Terminal size: 0.14 ... 1.5 mm<sup>2</sup> (26 ... 16 AWG)            Inaccuracy: ±1% of full scale (in voltage and current modes)</p>
<p>Reference voltage output for analog inputs +10V DC (Term. 4)</p>	<p>Max. 20 mA output            Inaccuracy: ±1%</p>
<p>Embedded fieldbus (X5)</p>	<p>Connector pitch 5 mm, maximum wire size 2.5 mm<sup>2</sup> (14 AWG)            Physical layer: EIA-485            Cable type: Shielded twisted pair cable with twisted pair for data and a wire or pair for signal ground, nominal impedance 100...165 ohms, for example Belden 9842            Transmission rate: 9.6 ... 115.2 kbit/s            Termination by switch</p>
<p>Safe torque off (STO) inputs IN1 and IN2 (Term. 37 and 38)</p>	<p>24 V DC logic levels: "0" &lt; 5 V, "1" &gt; 13 V  <math>R_{in}</math>: 2.47 kohm            Terminal size: 0.14 ... 1.5 mm<sup>2</sup> (26 ... 16 AWG)</p>
<p>Control panel - drive connection</p>	<p>EIA-485, male RJ-45 connector, max. cable length 100 m (328 ft)</p>
<p>Control panel - PC connection</p>	<p>USB Type Mini-B, max. cable length 2 m (6.5 ft)</p>

## Isolation areas

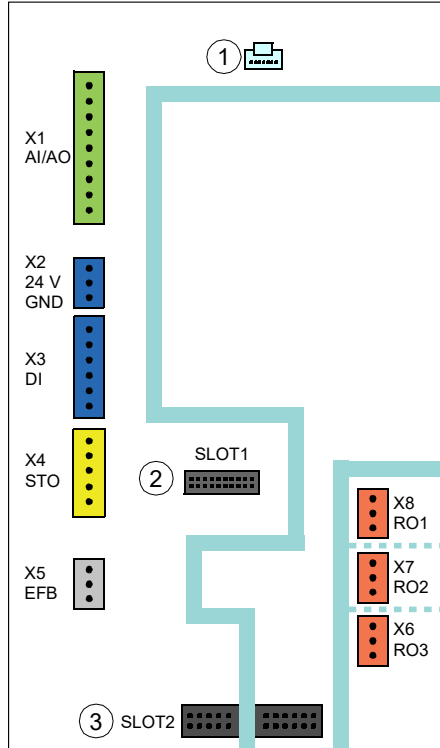

1

Panel port

2

Fieldbus extension

3

I/O extension



Reinforced insulation (IEC/EN 61800-5-1:2007, UL 61800-5-1 First edition)



Functional insulation (IEC/EN 61800-5-1:2007, UL 61800-5-1 First edition)

**Below altitudes 4000 m (13123 ft):** The terminals on the control unit fulfill the Protective Extra Low Voltage (PELV) requirements (EN 50178): There is reinforced insulation between the user terminals which only accept ELV voltages and terminals that accept higher voltages (relay outputs).

# 144 Control unit

Ground isolation diagram

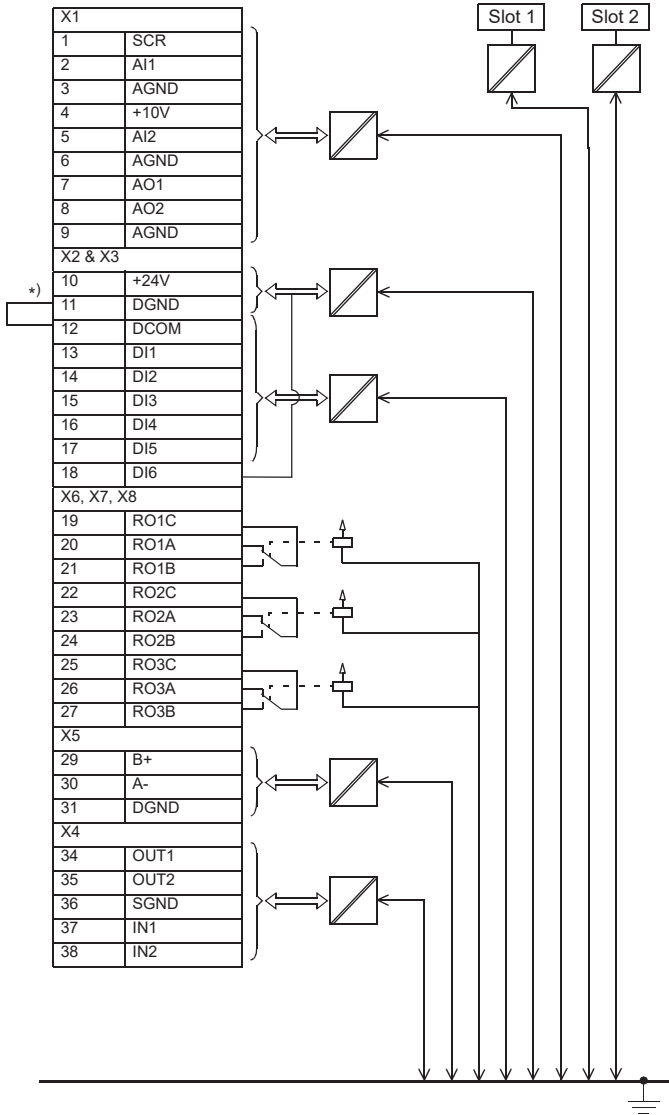

\*) Jumper installed at factory

## CCU-24 (R6...R9)

External power supply Term. 40, 41	Maximum power: 36 W, 1.50 A at 24 V AC/DC $\pm 10\%$ as standard Terminal size: 0.14 ... 2.5 mm <sup>2</sup> (26 ... 14 AWG)
+24 V DC output (Term. 10)	Total load capacity of this output is 6.0 W (250 mA / 24 V) minus the power taken by the option modules installed on board. Terminal size: 0.14 ... 2.5 mm <sup>2</sup> (26 ... 14 AWG)
Digital inputs DI1...DI6 (Term. 13...18)	<p>Input type: NPN/PNP Terminal size: 0.14 ... 2.5 mm<sup>2</sup> (26 ... 14 AWG)</p> <p><u>DI1...DI4 (Term. 13...16)</u> 12/24 V DC logic levels: "0" &lt; 4 V, "1" &gt; 8 V <math>R_{in}</math>: 3 kohm Hardware filtering: 0.04 ms, digital filtering: 2 ms sampling</p> <p><u>DI5 (Term.17)</u> Can be used as a digital or frequency input. 12/24 V DC logic levels: "0" &lt; 4 V, "1" &gt; 8 V <math>R_{in}</math>: 3 kohm Max. frequency: 16 kHz Symmetrical signal (duty cycle D = 0.50)</p> <p><u>DI6 (Term.18)</u> Can be used as a digital or PTC input. 12/24 V DC logic levels: "0" &lt; 3 V, "1" &gt; 8 V <math>R_{in}</math>: 3 kohm Max. frequency: 16 kHz Symmetrical signal (duty cycle D = 0.50) Hardware filtering: 0.04 ms, digital filtering: 2 ms sampling</p> <p><b>Note:</b> DI6 is not supported in the NPN configuration. PTC mode – PTC thermistor can be connected between DI6 and +24 V DC: &lt; 1.5 kohm = '1' (low temperature), &gt; 4 kohm = '0' (high temperature), open circuit = '0' (high temperature). DI6 is not a reinforced/double insulated input. Connecting the motor PTC sensor to this input requires usage of a reinforced/double insulated PTC sensor inside the motor</p>
Relay outputs RO1...RO3 (Term. 19...27)	250 V AC / 30 V DC, 2 A. Terminal size: 0.14 ... 2.5 mm <sup>2</sup> (26 ... 14 AWG)  See section <a href="#">Isolation areas (page 147)</a> .
Analog inputs AI1 and AI2 (Term. 2 and 5)	Current/voltage input mode selected with a parameter, see <a href="#">Connecting motor temperature sensors to the drive (page 137)</a> . Current input: 0(4)...20 mA, $R_{in}$ : 100 ohm Voltage input: 0(2)...10 V, $R_{in}$ : > 200 kohm Terminal size: 0.14 ... 2.5 mm <sup>2</sup> (26 ... 14 AWG) Inaccuracy: typical $\pm 1\%$ , max. $\pm 1.5\%$ of full scale Inaccuracy for Pt100 sensors: 10 °C

## 146 Control unit

<p>Analog outputs AO1 and AO2 (Term. 7 and 8)</p>	<p>Current/voltage output mode for AO1 selected with a parameter, see <a href="#">Connection for obtaining 0...10 V from analog output 2 (AO2)</a> (page 139).            Current output: 0...20 mA, <math>R_{load} &lt; 500 \text{ ohm}</math>            Voltage input: 0...10 V, <math>R_{load} &gt; 100 \text{ kohm}</math> (AO1 only)            Terminal size: 0.14 ... 2.5 mm<sup>2</sup> (26 ... 14 AWG)            Inaccuracy: <math>\pm 1\%</math> of full scale (in voltage and current modes)</p>
<p>Reference voltage output for analog inputs +10V DC (Term. 4)</p>	<p>Max. 20 mA output            Inaccuracy: <math>\pm 1\%</math></p>
<p>Safe torque off (STO) inputs IN1 and IN2 (Term. 37 and 38)</p>	<p>24 V DC logic levels: "0" &lt; 5 V, "1" &gt; 13 V  <math>R_{in}</math>: 2.47 kohm            Terminal size: 0.14 ... 2.5 mm<sup>2</sup> (26 ... 14 AWG)</p>
<p>Embedded fieldbus (X5)</p>	<p>Connector pitch 5 mm, maximum wire size 2.5 mm<sup>2</sup> (14 AWG)            Physical layer: EIA-485            Cable type: Shielded twisted pair cable with twisted pair for data and a wire or pair for signal ground, nominal impedance 100...165 ohms, for example Belden 9842            Transmission rate: 9.6 ... 115.2 kbit/s            Termination by switch</p>
<p>Control panel - drive connection</p>	<p>EIA-485, male RJ-45 connector, max. cable length 100 m</p>
<p>Control panel - PC connection</p>	<p>USB Type Mini-B, max. cable length 2 m</p>

## Isolation areas

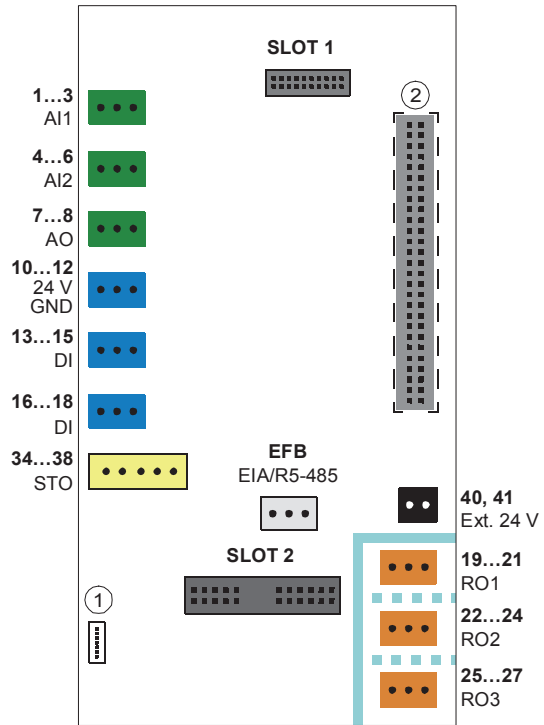

1	Panel port
2	Power unit connection at the bottom of the control unit
	Reinforced insulation (IEC/EN 61800-5-1:2007, UL 61800-5-1 First edition)
	Functional insulation (IEC/EN 61800-5-1:2007, UL 61800-5-1 First edition)
<p>The terminals on the control unit fulfill the Protective Extra Low Voltage (PELV) requirements (EN 50178): There is reinforced insulation between the user terminals which only accept ELV voltages and terminals that accept higher voltages (relay outputs).</p> <p><b>Note:</b> There is functional insulation also between the individual relay outputs.</p>	

148 Control unit

**Note:** There is reinforced insulation on the power unit.

Ground isolation diagram

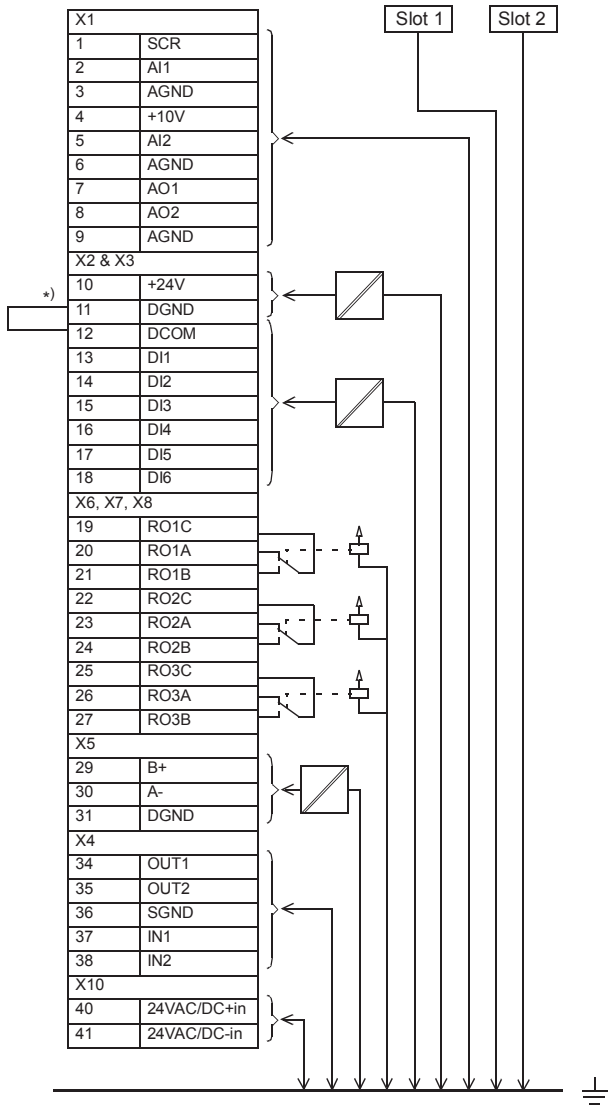

\*) Jumper installed at factory

## 8

# Installation checklist

---

## Contents of this chapter

This chapter contains a checklist for the mechanical and electrical installation of the drive.

## Checklist

Examine the mechanical and electrical installation of the drive before start-up. Go through the checklist together with another person.

---

**WARNING!**

Obey the safety instructions of the drive. If you ignore them, injury or death, or damage to the equipment can occur. If you are not a qualified electrical professional, do not do installation, commissioning or maintenance work.

---

**WARNING!**

Do the steps in section [Electrical safety precautions \(page 20\)](#) before you start the work.

---

<b>Make sure that ...</b>	<input checked="" type="checkbox"/>
The ambient operating conditions meet the drive ambient conditions specification and enclosure rating (IP code).	<input type="checkbox"/>
The supply voltage matches the nominal input voltage of the drive. See the type designation label.	<input type="checkbox"/>

---

# 150 Installation checklist

<b>Make sure that ...</b>	<input checked="" type="checkbox"/>
The insulation resistance of the input power cable, motor cable and motor is measured according to local regulations and the manuals of the drive.	<input type="checkbox"/>
The drive is attached securely on an even, vertical and non-flammable wall.	<input type="checkbox"/>
The cooling air can flow freely in and out of the drive.	<input type="checkbox"/>
<u>If the drive is connected to a network other than a symmetrically grounded TN-S system:</u> You have done all the required modifications (for example, you may need to disconnect the EMC filter or ground-to-phase varistor) the electrical installation instructions.	<input type="checkbox"/>
Appropriate AC fuses and main disconnecting device are installed.	<input type="checkbox"/>
There is an adequately sized protective earth (ground) conductor(s) between the drive and the switchboard, the conductor is connected to correct terminal, and the terminal is tightened to the correct torque. Grounding has also been measured according to the regulations.	<input type="checkbox"/>
The input power cable is connected to the correct terminals, the phase order is correct, and the terminals are tightened to the correct torque.	<input type="checkbox"/>
There is an adequately sized protective earth (ground) conductor between the motor and the drive. The conductor is connected to the correct terminal, and the terminal is tightened to the correct torque. Grounding has also been measured according to the regulations.	<input type="checkbox"/>
The motor cable is connected to the correct terminals, the phase order is correct, and the terminals are tightened to the correct torque.	<input type="checkbox"/>
The motor cable is routed away from other cables.	<input type="checkbox"/>
No power factor compensation capacitors are connected to the motor cable.	<input type="checkbox"/>
<u>If an external brake resistor is connected to the drive:</u> There is an adequately sized protective earth (ground) conductor between the brake resistor and the drive, and the conductor is connected to the correct terminal, and the terminals are tightened to the correct torque. Grounding has also been measured according to the regulations.	<input type="checkbox"/>
<u>If an external brake resistor is connected to the drive:</u> The brake resistor cable is connected to the correct terminals, and the terminals are tightened to the correct torque.	<input type="checkbox"/>
<u>If an external brake resistor is connected to the drive:</u> The brake resistor cable is routed away from other cables.	<input type="checkbox"/>

<b>Make sure that ...</b>	<input checked="" type="checkbox"/>
The control cables are connected to the correct terminals, and the terminals are tightened to the correct torque.	<input type="checkbox"/>
<u>If a drive bypass connection will be used:</u> The direct-on-line contactor of the motor and the drive output contactor are either mechanically and/or electrically interlocked, that is, they cannot be closed at the same time. A thermal overload device must be used for protection when bypassing the drive. Refer to local codes and regulations.	<input type="checkbox"/>
There are no tools, foreign objects or dust from drilling inside the drive.	<input type="checkbox"/>
The area in front of the drive is clean: the drive cooling fan cannot draw any dust or dirt inside.	<input type="checkbox"/>
Drive covers and the terminal box cover of the motor are in place.	<input type="checkbox"/>
The motor and the driven equipment are ready for power-up.	<input type="checkbox"/>

---



9

# Maintenance

---

## Contents of this chapter

This chapter contains maintenance instructions.

## Maintenance intervals

The tables below show the maintenance tasks which can be done by the end user. The complete maintenance schedule is available on the Internet ([new.abb.com/drives/services/maintenance/preventive-maintenance](http://new.abb.com/drives/services/maintenance/preventive-maintenance)). For more information, consult your local ABB Service representative ([www.abb.com/searchchannels](http://www.abb.com/searchchannels)).

### ■ Description of symbols

Action	Description
I	Inspection (visual inspection and maintenance action if needed)
P	Performance of on/off-site work (commissioning, tests, measurements or other work)
R	Replacement

---

■ Recommended maintenance intervals after start-up

Action	Description
P	Quality of supply voltage
I	Spare parts
P	Capacitor reforming for spare modules and spare capacitors, see <a href="#">Capacitors (page 163)</a>
I	Tightness of terminals
I	Dustiness, corrosion or temperature
P	Heatsink cleaning, see <a href="#">Cleaning the heatsink (page 155)</a>

Component	Years from start-up						
	3	6	9	12	15	18	21
<b>Cooling</b>							
<b>Fans, IP20 frames R1 to R9</b>							
Main cooling fan R1...R4: page 157, R5: page 159		R		R		R	
Main cooling fan LONGLIFE R6...R8: page 159, R9; page 160			R			R	
Auxiliary cooling fan (LONGLIFE) for circuit boards, R5...R9 only: page 161			R			R	
<b>Functional safety</b>							
Safety function test						I	
	See the maintenance information of the safety function.						
Safety component expiry (Mission time, $T_M$ )	20 years						

**Note:**

- Maintenance and component replacement intervals are based on the assumption that the equipment is operated within the specified ratings and ambient conditions. ABB recommends annual drive inspections to ensure the highest reliability and optimum performance.
- Long term operation near the specified maximum ratings or ambient conditions may require shorter maintenance intervals for certain components. Consult your local ABB Service representative for additional maintenance recommendations.

## Cleaning the exterior of the drive

---



### WARNING!

Obey the safety instructions of the drive. If you ignore them, injury or death, or damage to the equipment can occur. If you are not a qualified electrical professional, do not do installation, commissioning or maintenance work.

---

1. Stop the drive and do the steps in section [Electrical safety precautions \(page 20\)](#) before you start the work.
  2. Clean the exterior of the drive. Use:
    - vacuum cleaner with an antistatic hose and nozzle
    - soft brush
    - dry or damp (not wet) cleaning cloth. Moisten with clean water, or mild detergent (pH 5...9 for metal, pH 5...7 for plastic).
- 



### WARNING!

Prevent water from entering the drive. Never use excessive amount of water, a hose, steam, etc.

---

## Cleaning the heatsink

The heatsink of the power module (drive, supply, inverter, converter, etc.) pick up dust from the cooling air. This can cause overtemperature warnings and faults. When necessary, clean the heatsink as follows.

---



### WARNING!

Use the required personal protective equipment. Wear protective gloves and long sleeves. Some parts have sharp edges.

---



### WARNING!

Use a vacuum cleaner with antistatic hose and nozzle, and wear a grounding wristband. Using a normal vacuum cleaner creates static discharges which can damage circuit boards.

---

1. Stop the drive and do the steps in section [Electrical safety precautions \(page 20\)](#) before you start the work.
  2. Remove the module cooling fan(s). Refer to the separate instructions.
  3. Protect the adjacent equipment from dust.
  4. Blow dry, clean and oil-free compressed air from bottom to top and simultaneously use a vacuum cleaner at the air outlet to trap the dust.
  5. Reinstall the cooling fan.
-

## Fans

See [Maintenance intervals \(page 153\)](#) for the fan replacement interval in average operation conditions.

Parameter 05.04 Fan on-time counter indicates the running time of the cooling fan. Reset the counter after a fan replacement. See the firmware manual.

In a speed-controlled fan, the speed of the fan matches the cooling needs. This increases the life span of the fan.

Main fans are speed controlled. When the drive is stopped, the main fan runs at low speed until the drive cools down. IP20 frames R5...R9 have auxiliary fans that are not speed controlled and run all the time when the control unit is powered.

Replacement fans are available from the manufacturer. Do not use other than specified spare parts.

---

## ■ Replacing the main cooling fan, IP20 frames R1...R4



### WARNING!

Obey the safety instructions of the drive. If you ignore them, injury or death, or damage to the equipment can occur.

1. Stop the drive and disconnect it from the power line. Wait for 5 minutes and then make sure by measuring that there is no voltage. See section [Electrical safety precautions \(page 20\)](#) before you start the work.

### R1...R3

2. Lever the fan assembly off the drive frame with for example a screwdriver (2a) and pull out the fan assembly (2b) until you can unplug the fan power supply wires from the fan assembly (2c).

3. Install the fan assembly in reverse order.

**R1...R2:** Put the connector and extra length of wires in the groove so that the wires do not get caught in the revolving fan.

**R3:** Put the extra length of wires under the fan assembly so that the wires do not get caught in the revolving fan.

### R1...R2

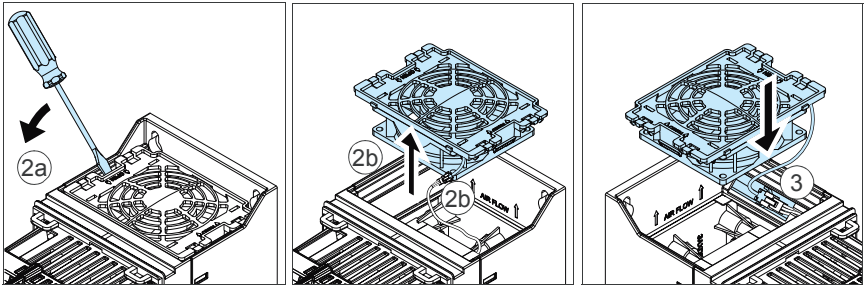

### R3

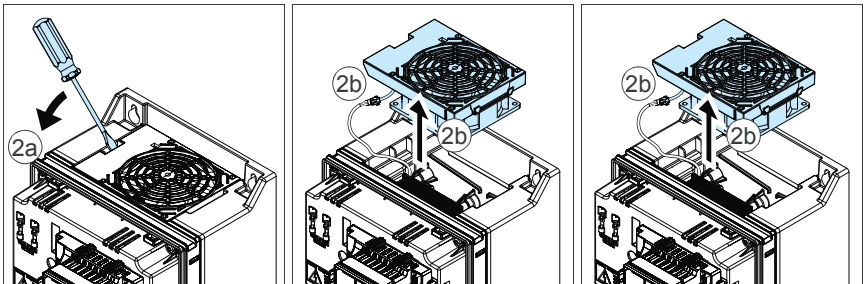

**R4**

1. Lever the fan assembly off the drive frame with for example a screwdriver (2a) and pull out the fan assembly (2b).
2. Install the fan assembly in reverse order.

**R4**

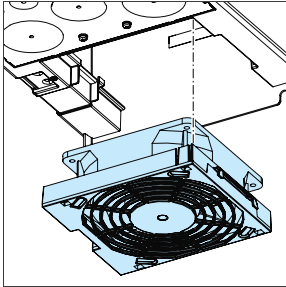
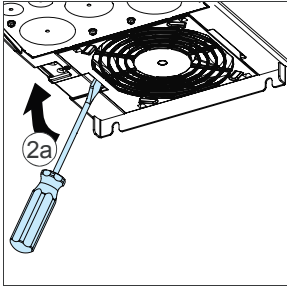

## ■ Replacing the main cooling fan, IP20 frames R5...R8



### WARNING!

Obey the safety instructions of the drive. If you ignore them, injury or death, or damage to the equipment can occur.

1. Stop the drive and disconnect it from the power line. Wait for 5 minutes and then make sure by measuring that there is no voltage. See section [Electrical safety precautions \(page 20\)](#) before you start the work.
2. Remove the two mounting screws of the fan mounting plate at the bottom of the drive.
3. Pull the fan mounting plate down from the side edge.
4. Unplug the fan power supply wires from the drive.
5. Lift the fan mounting plate off.
6. Remove the fan from the mounting plate.
7. Install the new fan in reverse order.

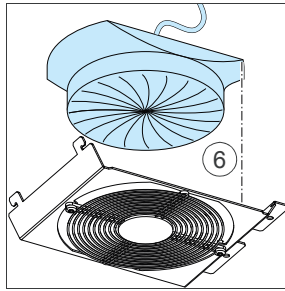
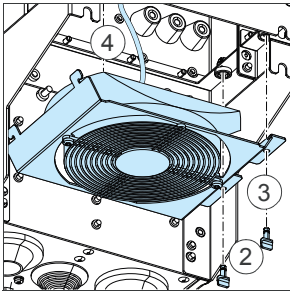

### ■ Replacing the main cooling fans, IP20 frame R9



**WARNING!**

Obey the safety instructions of the drive. If you ignore them, injury or death, or damage to the equipment can occur.

1. Stop the drive and disconnect it from the power line. Wait for 5 minutes and then make sure by measuring that there is no voltage. See section [Electrical safety precautions \(page 20\)](#) before you start the work.
2. Remove the two mounting screws of the fan mounting plate.
3. Turn the mounting plate downwards.
4. Unplug the fan power supply wires from the drive.
5. Remove the fan mounting plate.
6. Remove the fans by removing the two mounting screws.
7. Install the new fans in reverse order.

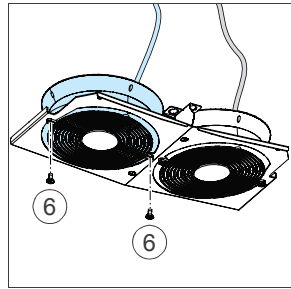
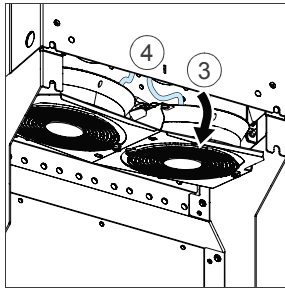
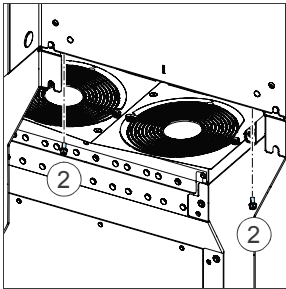

## ■ Replacing the auxiliary cooling fan, IP20 frames R6...R9



### WARNING!

Obey the safety instructions of the drive. If you ignore them, injury or death, or damage to the equipment can occur.

1. Stop the drive and disconnect it from the power line. Wait for 5 minutes and then make sure by measuring that there is no voltage. See section [Electrical safety precautions \(page 20\)](#) before you start the work.
2. Remove the front cover. See section [Installing the drive vertically, frames R6...R9 \(page 61\)](#).
3. Unplug fan power supply wires from the drive.
4. Release the retaining clips.
5. Lift the fan off.
6. Install the new fan in reverse order.

**Note:** Make sure that the arrow on the fan points up.

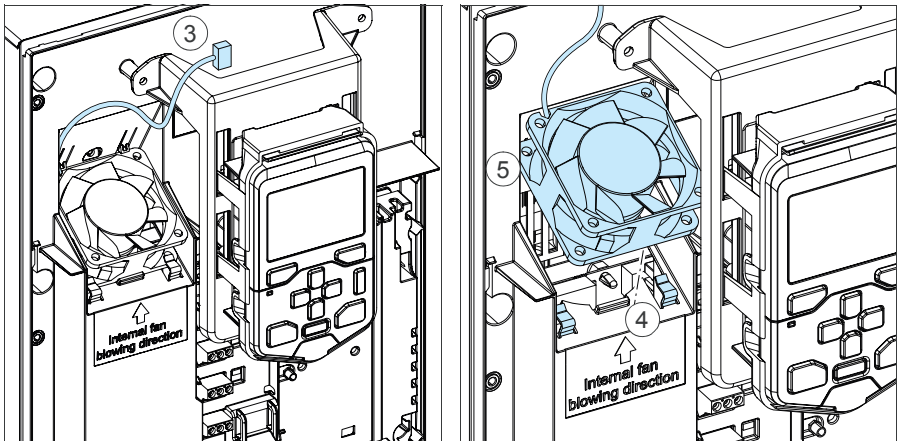

## ■ Replacing the auxiliary cooling fan, IP20 frame R5



### WARNING!

Obey the safety instructions of the drive. If you ignore them, injury or death, or damage to the equipment can occur.

1. Stop the drive and disconnect it from the power line. Wait for 5 minutes and then make sure by measuring that there is no voltage. See section [Electrical safety precautions \(page 20\)](#) before you start the work.
2. Remove the control panel: Press the retaining clip of the IP55 panel cover (2a) and open the cover (2b). Press the retaining clip of the control panel at the top (2c) and pull it forward from the top edge (2d).
3. Remove the front cover: Loosen the retaining screws (R4:6 pieces, R5: IP21 2 pieces; IP55 8 pieces) with a screwdriver (3a) and lift the cover from the bottom outwards (3b) and then up (3c).
4. Unplug the fan power supply wires from the drive.
5. Detach the fan cable from the clips.
6. Pull the fan off.
7. Install the new fan in reverse order.

**Note:** Make sure that the arrow on the fan points down.

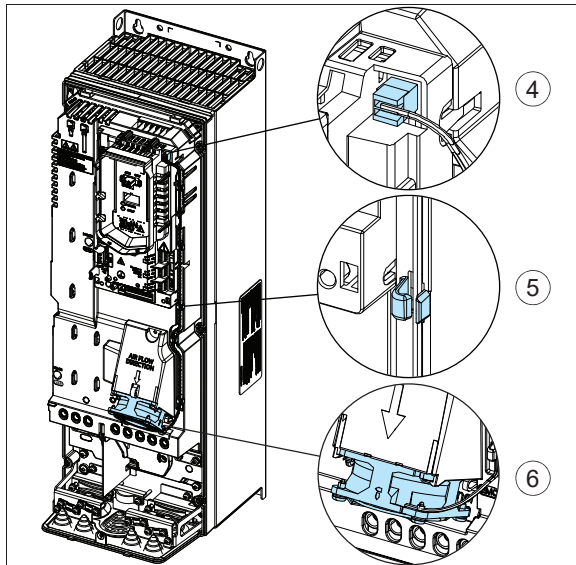
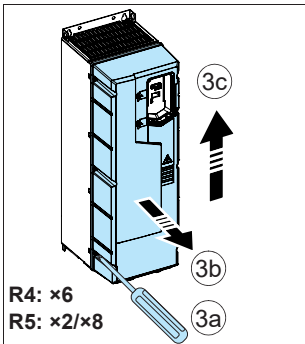
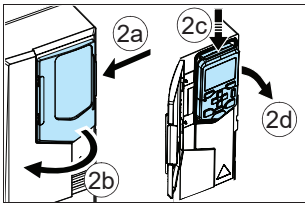

## Capacitors

The intermediate DC circuit of the drive contains several electrolytic capacitors. Operating time, load, and surrounding air temperature have an effect on the life of the capacitors. Capacitor life can be extended by decreasing the surrounding air temperature.

Capacitor failure is usually followed by damage to the unit and an input cable fuse failure, or a fault trip. If you think that any capacitors in the drive have failed, contact ABB.

### ■ Reforming the capacitors

The capacitors must be reformed if the drive has not been powered (either in storage or unused) for a year or more. The manufacturing date is on the type designation label. For information on reforming the capacitors, refer to [Capacitor reforming instructions \(3BFE64059629 \[English\]\)](#).

## Control Panel

For detailed information on the control panel, see *ACS-BP-S user's manual (3AXD50000032527 [English])*.

### ■ Cleaning the control panel

Use a soft damp cloth to clean the control panel. Avoid harsh cleaners which could scratch the display window.

---

## LEDs

### ■ Drive LEDs

There is a green POWER and a red FAULT LED on the front of the drive. They are visible through the panel cover but invisible if a control panel is attached to the drive. The table below describes the drive LED indications.

<b>Drive LEDs POWER and FAULT, on the front of the drive, under the control panel / panel cover</b>				
<b>If a control panel is attached to the drive, switch to remote control (otherwise a fault will be generated), and then remove the panel to be able to see the LEDs</b>				
<b>LEDs off</b>	<b>LED lit and steady</b>		<b>LED blinking</b>	
No power	Green (POWER)	Power supply on the board OK	Green (POWER)	<u>Blinking:</u> Drive in an alarm state <u>Blinking for one second:</u> Drive selected on the control panel when multiple drives are connected to the same panel bus.
	Red (FAULT)	Active fault in the drive. To reset the fault, press RESET from the control panel or switch off the drive power.	Red (FAULT)	Active fault in the drive. To reset the fault, switch off the drive power.

## ■ Control panel LEDs

The control panel has one LED. The table below describes the control panel LED indications. For more information see *ACS-AP-I, -S, -W and ACH-AP-H, -W Assistant control panels user's manual* (3AUA0000085685 [English]).

Control panel LED, at the left edge of the control panel				
LED off	LED lit and steady		LED blinking/flickering	
Panel has no power	Green	Drive functioning normally. Connection between the drive and control panel may be faulty or lost, or the panel and drive may be incompatible. Check the control panel display.	Green	<u>Blinking:</u> Active warning in the drive <u>Flickering:</u> Data transferred between the PC tool and drive through the USB connection of the control panel
	Red	Check the display to see where the fault is. <ul style="list-style-type: none"> <li>Active fault in the drive. Reset the fault.</li> <li>Active fault in another drive in the panel bus. Switch to the drive in question and check and re-set the fault.</li> </ul>	Red	Active fault in the drive. To reset the fault, cycle the drive power.
			Blue	Panels with a Bluetooth interface only. <u>Blinking:</u> Bluetooth interface is enabled. It is in discoverable mode and ready for pairing. <u>Flickering:</u> Data is transferred through the Bluetooth interface of the control panel.

## Functional safety components

The mission time of functional safety components is 20 years which equals the time during which failure rates of electronic components remain constant. This applies to the components of the standard Safe torque off circuit as well as any modules, relays and, typically, any other components that are part of functional safety circuits.

The expiry of mission time terminates the certification and SIL/PL classification of the safety function. The following options exist:

- Renewal of the whole drive and all optional functional safety module(s) and components.
- Renewal of the components in the safety function circuit. In practice, this is economical only with larger drives that have replaceable circuit boards and other components such as relays.

Note that some of the components may already have been renewed earlier, restarting their mission time. The remaining mission time of the whole circuit is however determined by its oldest component.

Contact your local ABB service representative for more information.

---



# Technical data

---

## Contents of this chapter

This chapter contains the technical specifications of the drive including the ratings, sizes and technical requirements, provisions for fulfilling the requirements for CE and other approval marks.

## Ratings

### ■ IEC

Type ACP510-01-	Input rating	Output ratings				
		Max. current	Nominal use		Light-duty use	
	$I_1$ A	$I_{max}$ A	$I_2$ A	$P_n$ kW	$I_{Ld}$ A	$P_{Ld}$ kW
3-phase $U_n = 400$ V (380...415 V)						
02A7-4	2.6	3.2	2.6	0.75	2.5	0.75
03A4-4	3.3	4.7	3.3	1.1	3.1	1.1
04A1-4	4.0	5.9	4.0	1.5	3.8	1.5
05A7-4	5.6	7.2	5.6	2.2	5.3	2.2
07A3-4	7.2	10.1	7.2	3.0	6.8	3.0
09A5-4	9.4	13.0	9.4	4.0	8.9	4.0

---

Type ACP510-01-	Input rating	Output ratings				
		Max. current	Nominal use		Light-duty use	
	$I_1$	$I_{max}$	$I_2$	$P_n$	$I_{Ld}$	$P_{Ld}$
	A	A	A	kW	A	kW
12A7-4	12.6	15.3	12.6	5.5	12.0	5.5
018A-4	17.0	22.7	17.0	7.5	16.2	7.5
026A-4	25.0	30.6	25.0	11.0	23.8	11.0
033A-4	32.0	44.3	32.0	15.0	30.4	15.0
039A-4	38.0	56.9	38.0	18.5	36.1	18.5
046A-4	45.0	67.9	45.0	22.0	42.8	22.0
062A-4	62	81	62	30	58	30
073A-4	73	110	73	37	68	37
088A-4	88	130	88	45	83	45
089A-4	89	130	89	45	83	45
106A-4	106	157	106	55	100	55
145A-4	145	178	145	75	138	75
169A-4	169	247	169	90	161	90
206A-4	206	287	206	110	196	110
246A-4	246	350	246	132	234	132
293A-4	293	418	293	160	278	160
363A-4	363	498	363	200	345	200
430A-4	430	545	430	250	400	200

<sup>1)</sup> Continuous current, no overloadability

See definitions and notes in section [Definitions \(page 168\)](#)

## Definitions

- $U_n$  Nominal output voltage of the drive. For input voltage range [ $U_1$ , see section [Electrical power network specification \(page 186\)](#)]. 50 Hz for IEC ratings.
- $I_1$  Nominal input current (rms) at 40 °C .
- $I_{max}$  Maximum output current. Available for two seconds at start.

$I_2$	Nominal output current. Maximum continuous rms output current allowed (no overload).
$P_n$	Nominal power of the drive. Typical motor power (no overload). The kilowatt ratings apply to most IEC 4-pole motors.
$I_{Ld}$	Continuous rms output current. Allows 10% overload for 1 minute every 10 minutes.
$P_{Ld}$	Typical motor power in light-duty use (10% overload).

## ■ Sizing

Drive sizing is based on the rated motor current, voltage and power. To achieve the rated motor power given in the table, the rated current of the drive must be higher than or equal to the rated motor current. Also the rated power of the drive must be higher than or equal to the rated motor power. The power ratings are the same regardless of the supply voltage within one voltage range.

**Note:** The ratings apply at ambient temperature of 40 °C for  $I_2$ . Above these temperatures derating is required.

**Note:** The DriveSize dimensioning PC tool available from ABB (<http://new.abb.com/drives/software-tools/drivesize>) is recommended for selecting the drive, motor and gear combination.

## ■ Derating

The output load capacity ( $I_2$ ,  $I_{Ld}$ ; note that  $I_{max}$  is not derated) decreases in certain situations. In situations, where full motor power is required, oversize the drive so that the total derated output current provides sufficient capacity to supply the required nominal voltage to run the motor.

**Note:** The DriveSize dimensioning PC tool available from ABB (<http://new.abb.com/drives/software-tools/drivesize>) is also suitable for derating.

**Note:** If several situations are present at a time, the effects of derating are cumulative:

$I_2$  (derated) or  $I_{Ld}$  (derated) = ( $I_2$  or  $I_{Ld}$ ) x (switching frequency derating) x (altitude derating) x (ambient temperature derating), where no derating = 1.0.

**Note:** The motor may have a derating on it too.

### Example 1, IEC: How to calculate the derated current

The IP20 drive type is ACP510-01-062A-4, which has drive output current of 62 A. Calculate the derated drive output current ( $I_2$ ) at 4kHz switching frequency, at 1500 m altitude and at 50 °C ambient temperature as follows:

1. **Switching frequency derating by derating factor (page 172):**  
No derating needed for 4 kHz.
2. **Altitude derating (page 171):**  
The derating factor for 1500 m is  $1 - 1/10\,000 \text{ m} \cdot (1500 - 1000) \text{ m} = 0.95$ .  
The derated drive output current becomes  $I_2 = 0.95 \cdot 62 \text{ A} = 58.9 \text{ A}$ .
3. **Surrounding air temperature derating, IP20 (page 170):**  
The derating factor for 50 °C ambient temperature = 0.90.  
The derated drive output current becomes then  $I_2 = 0.90 \cdot 58.9 \text{ A} = 53.01 \text{ A}$ .

**Example 2, IEC:** How to calculate the required drive

If your application requires continuous 12.0 A of motor current ( $I_2$ ) at 8 kHz switching frequency, the supply voltage is 400 V and the drive is situated at 1500 m altitude and at 35 °C ambient temperature, calculate the appropriate IP20 drive size requirement as follows:

1. **Switching frequency derating by derating factor (page 172):**  
The minimum size required is  $I_2 = 12.0 \text{ A} / 0.65 = 18.46 \text{ A}$ ,  
where 0.65 is the derating for 8 kHz switching frequency (frames R2...R3).
2. **Altitude derating (page 171):**  
The derating factor for 1500 m is  $1 - 1/10\,000 \text{ m} \cdot (1500 - 1000) \text{ m} = 0.95$ .  
The minimum size required becomes then  $I_2 = 18.46 \text{ A} / 0.95 = 19.43 \text{ A}$ .
3. **Surrounding air temperature derating, IP20 (page 170):**  
No derating needed for 35 °C ambient temperature.

Referring to  $I_2$  in the ratings tables (starting from page 167), drive type ACP510-01-026A-4 exceeds the  $I_2$  requirement of 19.43 A.

**Surrounding air temperature derating, IP20**

In the temperature range +40...50 °C the rated output current is derated by 1% for every added 1 °C (The output current can be calculated by multiplying the current given in the rating table by the derating factor (k) in the diagram below).

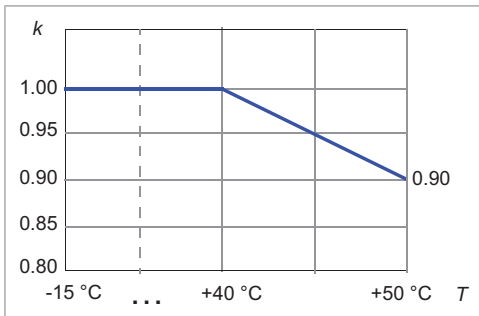

## Altitude derating

In altitudes 1000...4000 m above sea level, the derating is 1% for every 100 m .

**Note:** There are special considerations in corner-grounded installations above 2000 m. Contact your local ABB representative for further information.

The output current is calculated by multiplying the current given in the rating table by the derating factor k, which for x meters ( $1000\text{ m} \leq x \leq 4000\text{ m}$ ) is:

$$K = 1 - 1/10000m * (X - 1000)m$$

### Altitude and surrounding air temperature

At altitudes from 1000...4000 m above sea level and temperature +40 °C the derating is 1 percentage point for every additional 100 m .

If surrounding air temperature is below +40 °C, the derating can be reduced by 1.5 percentage point for every 1 °C reduction in temperature.

A few combined altitude and temperature derating curves for 1000...4000 m are shown below. For example, if the temperature is 30 °C, the derating factor is  $1 - 1.5\% \cdot 10 = 0.85$ .

For a more accurate derating, use the DriveSize PC tool.

---

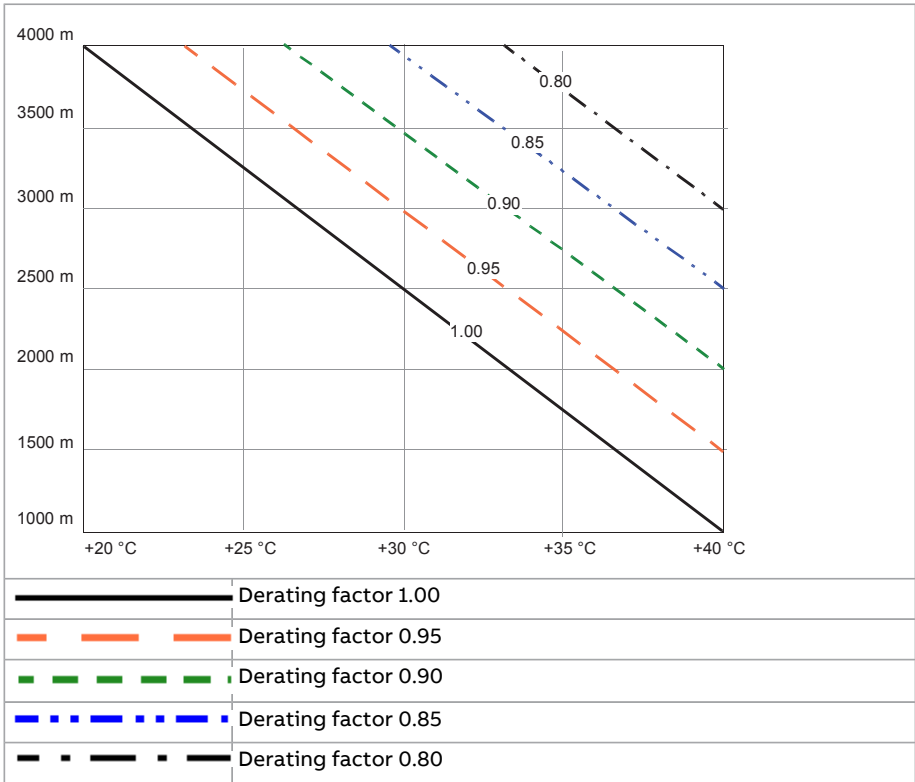

**Note:** Check the supply network compatibility restrictions above 2000 m, see [Installation site altitude](#) (page 194). Check also PELV limitation on relay output terminals above 2000 m, see sections [Isolation areas](#) (page 143) for frames R1...R5 and [Isolation areas](#) (page 147) for frames R6...R9.

**Switching frequency derating by derating factor**

The output current is calculated by multiplying the current given in the rating table by the derating factor given in the table below.

**Note:** If you change the minimum switching frequency with parameter 97.02, derate according to the table below. Changing parameter 97.01 does not require derating.

**IEC**

Frame size	Type ACP510-01-	Derating factor (k) for the minimum switching frequencies at 40 °C				
		1 kHz	2 kHz	4 kHz	8 kHz	12 kHz
3-phase $U_n = 400$ V						
R1	02A7-4...12A7-4	1	1	1	0.67	0.50
R2	018A-4...026A-4	1	1	1	0.65	0.48
R3	033A-4...046A-4	1	1	1	0.65	0.48
R4	062A-4	1	1	1	0.82	0.64
R4 v2	062A-4	1	1	1	0.65	0.48
R4	073A-4	1	1	1	0.73	0.55
R4 v2	073A-4...089A-4	1	1	1	0.65	0.47
R5	088A-4...106A-4	1	1	1	0.71	0.57
R6	145A-4	1	0.97	0.84	0.66	0.52
R7	169A-4...206A-4	1	0.98	0.89	0.71	0.53
R8	246A-4...293A-4	1	0.96	0.82	0.61	0.45
R9	363A-4...430A-4	1	0.95	0.79	0.58	0.43

**Switching frequency derating with actual output current values**

These tables show the output current values with different switching frequencies. Note that other derating factors, for example ambient temperature and altitude, may also affect to the output current.

**IEC**

Frame size	Type ACP510-01-	Nominal output	Nominal output current ( $I_2$ ) for the minimum switching frequencies at 40 °C				
			$I_2$	1 kHz	2 kHz	4 kHz	8 kHz
		A	A	A	A	A	A
3-phase $U_n = 400$ V							
R1	02A7-4	2.6	2.6	2.6	2.6	1.7	1.3
R1	03A4-4	3.3	3.3	3.3	3.3	2.2	1.7
R1	04A1-4	4.0	4.0	4.0	4.0	2.7	2.0
R1	05A7-4	5.6	5.6	5.6	5.6	3.8	2.8
R1	07A3-4	7.2	7.2	7.2	7.2	4.8	3.6

Frame size	Type ACP510-01-	Nominal output	Nominal output current ( $I_2$ ) for the minimum switching frequencies at 40 °C				
			$I_2$	1 kHz	2 kHz	4 kHz	8 kHz
		A	A	A	A	A	A
R1	09A5-4	9.4	9.4	9.4	9.4	6.3	4.7
R1	12A7-4	12.6	12.6	12.6	12.6	8.4	6.3
R2	018A-4	17.0	17.0	17.0	17.0	11.1	8.2
R2	026A-4	25.0	25.0	25.0	25.0	16.3	12.0
R3	033A-4	32.0	32.0	32.0	32.0	20.8	15.4
R3	039A-4	38.0	38.0	38.0	38.0	24.7	18.2
R3	046A-4	45.0	45.0	45.0	45.0	29.3	21.6
R4	062A-4	62	62	62	62	51	39.7
R4 v2	062A-4	62	62	62	62	40.1	29.7
R4	073A-4	73	73	73	73	53	40.2
R4 v2	073A-4	73	73	73	73	47.2	34.6
R5	088A-4	88	88	88	88	62	50
R4 v2	089A-4	89	89	89	89	58	41.9
R5	106A-4	106	106	106	106	75	60
R6	145A-4	145	145	141	122	96	75
R7	169A-4	169	169	166	150	120	90
R7	206A-4	206	206	202	183	146	109
R8	246A-4	246	246	236	202	150	111
R8	293A-4	293	293	281	240	179	132
R9	363A-4	363	363	345	287	211	156
R9	430A-4	430	430	409	340	249	185

**Output frequency derating**

Output frequency derating applies for ratings up to ACP510-01-106A-4 (R5). Inverter output current is limited by the following factor k below 5 Hz absolute inverter output frequency  $f_{abs}$ .

$$k = 2/3 + 1/3 \cdot (f_{abs} / 5 \text{ Hz})$$

## Fuses (IEC)

gG as well as uR or aR fuses for protection against short-circuit in the input power cable or drive are listed below. Either fuse type can be used for frames R1...R9 if it operates rapidly enough. The operating time depends on the supply network impedance and the cross-sectional area and length of the supply cable.

**Note 1:** See also [Implementing short-circuit and thermal overload protection \(page 80\)](#).

**Note 2:** Fuses with higher current rating than the recommended ones must not be used.

**Note 3:** Fuses from other manufacturers can be used if they meet the ratings and the melting curve of the fuse does not exceed the melting curve of the fuse mentioned in the table.

### ■ gG fuses

Check on the fuse time-current curve to ensure the operating time of the fuse is below 0.5 seconds. Obey the local regulations.

Type ACP510- 01-	Min. short- circuit current <sup>1)</sup>	Input current	gG (IEC 60269)				
			Nominal current	$I^2t$	Voltage rating	ABB type	IEC 60269 size
			A	A <sup>2</sup> s	V		
3-phase $U_n = 400\text{ V}$							
02A7-4	32	2.6	4	55	500	OFAF000H4	000
03A4-4	48	3.3	6	110	500	OFAF000H6	000
04A1-4	48	4.0	6	110	500	OFAF000H6	000
05A7-4	80	5.6	10	360	500	OFAF000H10	000
07A3-4	80	7.2	10	360	500	OFAF000H10	000
09A5-4	128	9.4	16	740	500	OFAF000H16	000
12A7-4	128	12.6	16	740	500	OFAF000H16	000
018A-4	200	17.0	25	2500	500	OFAF000H25	000
026A-4	256	25.0	32	4000	500	OFAF000H32	000
033A-4	320	32.0	40	7700	500	OFAF000H40	000
039A-4	400	38.0	50	16000	500	OFAF000H50	000
046A-4	500	45.0	63	20100	500	OFAF000H63	000
062A-4	800	62	80	37500	500	OFAF000H80	000
073A-4	1000	73	100	65000	500	OFAF000H100	000

Type ACP510- 01-	Min. short- circuit current <sup>1)</sup>	Input current	gG (IEC 60269)				
			Nominal current	$I^2t$	Voltage rating	ABB type	IEC 60269 size
			A	A <sup>2</sup> s	V		
088A-4	1000	88	100	65000	500	OFAF000H100	000
089A-4	1000	89	100	65000	500	OFAF000H100	000
106A-4	1300	106	125	103000	500	OFAF00H125	00
145A-4	1700	145	160	185000	500	OFAF00H160	00
169A-4	3300	169	250	600000	500	OFAF0H250	0
206A-4	5500	206	315	710000	500	OFAF1H315	1
246A-4	6400	246	355	920000	500	OFAF1H355	1
293A-4	7800	293	425	1300000	500	OFAF2H425	2
363A-4	9400	363	500	2000000	500	OFAF2H500	2
430A-4	10200	430	630	2800000	500	OFAF3H630	3

<sup>1)</sup> Minimum short-circuit current of the installation

## ■ uR and aR fuses

Type ACP510- 01-	Min. short- circuit current <sup>1)</sup>	Input current	uR or aR (DIN 43620 blade style)				
			Nominal current	$I^2t$	Voltage rating	Bussmann type	IEC 60269 size
			A	A <sup>2</sup> s	V		
3-phase $U_n = 400$ V							
02A7-4	65	2.6	25	130	690	170M1561	000
03A4-4	65	3.3	25	130	690	170M1561	000
04A1-4	65	4.0	25	130	690	170M1561	000
05A7-4	65	5.6	25	130	690	170M1561	000
07A3-4	65	7.2	25	130	690	170M1561	000
09A5-4	65	9.4	25	130	690	170M1561	000
12A7-4	65	12.6	25	130	690	170M1561	000
018A-4	120	17.0	40	460	690	170M1563	000
026A-4	120	25.0	40	460	690	170M1563	000
033A-4	170	32.0	63	1450	690	170M1565	000

Type ACP510- 01-	Min. short- circuit current <sup>1)</sup>	Input current	uR or aR (DIN 43620 blade style)				
			Nominal current	$I^2t$	Voltage rating	Bussmann type	IEC 60269 size
			A	A <sup>2</sup> s	V		
039A-4	170	38.0	63	1450	690	170M1565	000
046A-4	280	45.0	80	2550	690	170M1566	000
062A-4	380	62	100	4650	690	170M1567	000
073A-4	480	73	125	8500	690	170M1568	000
088A-4	700	88	160	16000	690	170M1569	000
089A-4	700	89	160	16000	690	170M1569	000
106A-4	1280	106	315	46500	690	170M3817	1
145A-4	1280	145	315	46500	690	170M3817	1
169A-4	1800	169	450	105000	690	170M5809	2
206A-4	2210	206	500	145000	690	170M5810	2
246A-4	3010	246	630	275000	690	170M5812	2
293A-4	4000	293	800	490000	690	170M6812D	3
363A-4	5550	363	1000	985000	690	170M6814D	3
430A-4	7800	430	1250	2150000	690	170M8554D	3

1) Minimum short-circuit current of the installation

Type ACP510- 01-	Min. short- circuit current <sup>1)</sup>	Input current	uR or aR (DIN 43653 bolted tags)				
			Nominal current	$I^2t$	Voltage rating	Bussmann type	IEC 60269 size
			A	A <sup>2</sup> s	V		
3-phase $U_n = 400$ V							
02A7-4	65	2.6	25	130	690	170M1311	000
03A4-4	65	3.3	25	130	690	170M1311	000
04A1-4	65	4.0	25	130	690	170M1311	000
05A7-4	65	5.6	25	130	690	170M1311	000
07A3-4	65	7.2	25	130	690	170M1311	000
09A5-4	65	9.4	25	130	690	170M1311	000
12A7-4	65	12.6	25	130	690	170M1311	000
018A-4	120	17.0	40	460	690	170M1313	000

Type ACP510- 01-	Min. short- circuit current <sup>1)</sup>	Input current	uR or aR (DIN 43653 bolted tags)				
			Nominal current	$I^2t$	Voltage rating	Bussmann type	IEC 60269 size
			A	A <sup>2</sup> s	V		
026A-4	120	25.0	40	460	690	170M1313	000
033A-4	170	32.0	63	1450	690	170M1315	000
039A-4	170	38.0	63	1450	690	170M1315	000
046A-4	280	45.0	80	2550	690	170M1316	000
062A-4	380	62	100	4650	690	170M1417	000
073A-4	480	73	125	8500	690	170M1318	000
088A-4	700	88	160	16000	690	170M1319	000
089A-4	700	88	160	16000	690	170M1319	000
106A-4	700	106	200	15000	690	170M3015	1
145A-4	1000	145	250	28500	690	170M3016	1
169A-4	1280	169	315	46500	690	170M3017	1
206A-4	1520	206	350	68500	690	170M3018	1
246A-4	3010	246	450	105000	690	170M5009	2
293A-4	4000	293	500	145000	690	170M5010	2
363A-4	5550	363	630	275000	690	170M5012	2
430A-4	7800	430	700	405000	690	170M5013	2

<sup>1)</sup> Minimum short-circuit current of the installation

## Circuit breakers (IEC)

The protective characteristics of circuit breakers depend on the type, construction and settings of the breakers. There are also limitations pertaining to the short-circuit capacity of the supply network.



### WARNING!

Pay special attention to the installation and placement of the breakers. Obey the manufacturer's instructions. Hot ionized gases can escape from the breaker enclosure in a short-circuit.

You can use the circuit breakers listed below. Other circuit breakers can be used with drive if they provide the same electrical characteristics. ABB does not assume any liability whatsoever for the correct function and protection with circuit breakers

not listed below. Furthermore, if the recommendations given by ABB are not obeyed, the drive can experience problems that the warranty does not cover.

Type ACP510-01-	MCBs and MCCBs					
	ABB type	Max. short-circuit	Tmax frame XT / T class	Tmax rating	Electronic release	SACE ordering code for breaker and release unit
		$I_{sc}$				
		kA	A	A	A	
3-phase $U_n = 400\text{ V}$						
02A7-4	S 203P-B/C/Z 10	20	N/A	N/A	N/A	N/A
03A4-4	S 203P-B/C/Z 10	20	N/A	N/A	N/A	N/A
04A1-4	S 203P-B/C/Z 10	20	N/A	N/A	N/A	N/A
05A7-4	S 203P-B/C/Z 10	20	N/A	N/A	N/A	N/A
07A3-4	S 203P-B/C/Z 10	20	N/A	N/A	N/A	N/A
09A5-4	S 203P-B/C/Z 10	20	N/A	N/A	N/A	N/A
12A7-4	S 203P-B/C/Z 16	20	N/A	N/A	N/A	N/A
018A-4	S 203P-B/C/Z 20	20	N/A	N/A	N/A	N/A
026A-4	S 203P-B/C/Z 25	20	N/A	N/A	N/A	N/A
033A-4	S 203P-B/C/Z 32	12	N/A	N/A	N/A	N/A
039A-4	S 203P-B/C/Z 40	12	N/A	N/A	N/A	N/A
046A-4	S 203P-B/C/Z 50	12	N/A	N/A	N/A	N/A
062A-4	S 803S-B/C 80	50	N/A	N/A	N/A	N/A
073A-4	S 803S-B/C 80	50	N/A	N/A	N/A	N/A
088A-4	S 803S-B/C 100	50	N/A	N/A	N/A	N/A
089A-4	S 803S-B/C 100	50	N/A	N/A	N/A	N/A
106A-4	S 803S-B/C 125	50	N/A	N/A	N/A	N/A
145A-4	XT4 L 250 Ekip LS/I In=250 3p F F	65	XT4	250	250	1SDA068555R1
169A-4	XT4 L 250 Ekip LS/I In=250 3p F F	65	XT4	250	250	1SDA068555R1
206A-4	T4 L 320 PR221DS-LS/I In=320 3p F F	65	T4	320	320	1SDA054141R1

Type ACP510-01-	MCBs and MCCBs					
	ABB type	Max. short-circuit	Tmax frame XT / T class	Tmax rating	Electronic release	SACE ordering code for breaker and release unit
		$I_{sc}$				
		kA	A	A	A	
246A-4	T5 L 400 PR221DS-LS/I In=400 3p F F	65	T5	400	400	
293A-4	T5 L 630 PR221DS-LS/I In=630 3p F F	65	T5	630	630	1SDA054420R1
363A-4	T5 L 630 PR221DS-LS/I In=630 3p F F	65	T5	630	630	1SDA054420R1
430A-4	T5 L 630 PR221DS-LS/I In=630 3p F F	65	T5	630	630	1SDA054420R1

## Dimensions, weights and free space requirements

Frame size	Dimensions and weights				
	IP20				
	H1*	H2*	W	D	Weight
	mm	mm	mm	mm	kg
R1	300	331	125	223	4
R2	393	432	125	229	6
R3	454	490	203	229	14.5
R4, R4 v2	600	636	203	257	18.5
R5	596	596	203	295	26.5
R6	549	548	252	369	42.6
R7	601	600	284	370	49.6
R8	677	680	300	393	62.8
R9	680	680	380	418	84.8

\*Height without cable box.

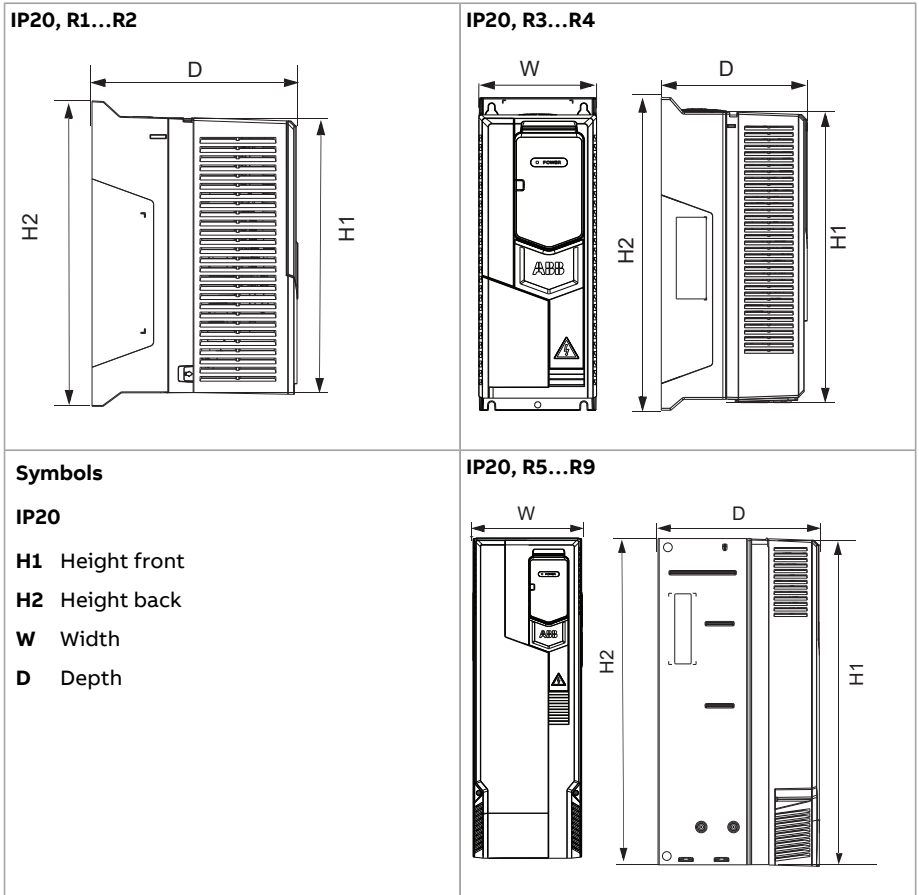

## Losses, cooling data and noise

The air flow direction is from bottom to top.

### ■ Cooling air flow, heat dissipation and noise for stand-alone drives

The table below specifies the heat dissipation in the main circuit at nominal load and in the control circuit with minimum load (I/O, options and panel not in use) and maximum load (all digital inputs and relays in the ON state, and the panel, fieldbus and fan in use). The total heat dissipation is the sum of the heat dissipation in the main and control circuits. Use the maximum heat dissipation when designing cabinet or electrical room cooling needs.

## IEC

Type ACP510-01-	Typical heat dissipation <sup>1)</sup>	Air flow	Noise	Frame size
	W	m <sup>3</sup> /h	dB(A)	
<b>3-phase <math>U_n = 400</math> V</b>				
02A7-4	44	43	59	R1
03A4-4	51	43	59	R1
04A1-4	60	43	59	R1
05A7-4	85	43	59	R1
07A3-4	98	43	59	R1
09A5-4	136	43	59	R1
12A7-4	213	43	59	R1
018A-4	240	101	64	R2
026A-4	383	101	64	R2
033A-4	492	179	76	R3
039A-4	523	179	76	R3
046A-4	672	179	76	R3
062A-4	873	134	69	R4
062A-4	776	150	70	R4 v2
073A-4	1120	134	69	R4
073A-4	858	150	70	R4 v2
088A-4	1139	139	63	R5
089A-4	1028	159	70	R4 v2
106A-4	1290	139	63	R5
145A-4	1960	435	67	R6
169A-4	2021	450	67	R7
206A-4	2785	450	67	R7
246A-4	3131	550	65	R8
293A-4	4071	550	65	R8
363A-4	4834	1150	68	R9
430A-4	6072	1150	68	R9

<sup>1)</sup> Typical drive losses when it operates at 90% of the motor nominal frequency and 100% of the drive nominal output current.

## Terminal and lead-through data for the power cables

### ■ IEC

Input, motor, resistor and DC cable lead-throughs, maximum wire sizes (per phase) and terminal screw sizes and tightening torques ( $T$ ) are given below.

Frame size	Cable lead-throughs		L1, L2, L3, T1/U, T2/V, T3/W terminals			Grounding terminals	
	Per cable type	$\varnothing^1$	Min wire size (solid/stranded) <sup>2)</sup>	Max wire size (solid/stranded)	$T$	Max wire size	$T$
	pcs	mm	mm <sup>2</sup>	mm <sup>2</sup>	N·m	mm <sup>2</sup>	N·m
3-phase $U_n = 400$ V							
R1	1	30	0.20/0.25	6/4	1.0	16/16	1.5
R2	1	30	0.5/0.5	16/16	1.5	16/16	1.5
R3	1	30	0.5/0.5	35/25	3.5	35/35	1.5
R4	1	45	0.5/0.5	50	4.0	35/35	2.9
R4 v2	1	45	1.5/1.5	70	5.5	35/35	2.9
R5	1	45	6	70	15	35/35 <sup>4)</sup>	2.2
R6	1	45	25	150	30	185 <sup>4)</sup>	9.8
R7	1	54	95	240	40	185 <sup>4)</sup>	9.8
R8	2	45	2×50	2×150	40	2×185 <sup>4)</sup>	9.8
R9	2	54	2×95	2×240	70	2×185 <sup>4)</sup>	9.8

1) Maximum cable diameter accepted. For the lead-through plate hole diameters, see chapter [Dimension drawings \(page 201\)](#).

2) **Note:** Minimum wire size does not necessarily have enough current capability for full load. Make sure the installation complies with local laws and regulations.

4) **Note:** Either cable lug (R5, see page 110) or clamp (R6...R9, see page 113)

**Note:** For the tightening torques of the grounding terminals, see sections [Connection procedure, frames R1...R4 \(page 100\)](#), [Connection procedure, frame R5 \(page 106\)](#) and [Connection procedure, frames R6...R9 \(page 112\)](#).

Frame size	Cable lead-throughs		R+, R-, UDC+ and UDC- terminals			
	Per cable type	∅ <sup>1)</sup>	Min wire size (solid/stranded) <sup>2)</sup>	Max wire size (solid/stranded)	T (Wire screw)	
	pcs	mm	mm <sup>2</sup>	mm <sup>2</sup>	Screw/Bolt	N·m
3-phase $U_n = 400$ V						
R1	1	23	0.20/0.25	6/4	3)	1.0
R2	1	23	0.5/0.5	16/16	3)	1.5
R3	1	23	0.5/0.5	35/25	4)	3.5
R4	1	39	0.5/0.5	50	4)	4.0
R4 v2	1	39	1.5/1.5	70	3)	5.5
R5	1	39	6	70	M5	15
R6	1	45	25	150	M8	30
R7	1	54	95	240	M10	30
R8	2	45	2×50	2×150	M10	40
R9	2	54	2×95	2×240	M12	70

1) Maximum cable diameter accepted. For the lead-through plate hole diameters, see chapter [Dimension drawings](#) (page 201).

2) **Note:** Minimum wire size does not necessarily have enough current carrying capability for full load. Make sure the installation complies with local laws and regulations.

3) Either cable lug (R5) or clamp (R6...R9) is used for grounding.

Frame size	Screwdrivers for the terminals of the main circuit
R1	Combo: Slot 4 mm and PH1
R2	Combo: Slot 4.5 mm and PH2
R3, R4	PH2
R4 v2	Torx

## Power cables

### ■ Typical power cable sizes, IEC

The table below gives copper cable types with concentric copper shield for the drives with nominal current. The value separated by the plus sign means the diameter of the PE conductor.

See page 183 for the cable lead-through sizes allowed for the selected drive frame size.

IEC type ACP510-01-	Frame size	Cu cable type <sup>1)</sup>
		mm <sup>2</sup>
3-phase U <sub>n</sub> = 400 V		
02A7-4	R1	3×1.5 + 1.5
03A4-4	R1	3×1.5 + 1.5
04A1-4	R1	3×1.5 + 1.5
05A7-4	R1	3×1.5 + 1.5
07A3-4	R1	3×1.5 + 1.5
09A5-4	R1	3×2.5 + 2.5
12A7-4	R1	3×2.5 + 2.5
018A-4	R2	3×2.5 + 2.5
026A-4	R2	3×6 + 6
033A-4	R3	3×10 + 10
039A-4	R3	3×10 + 10
046A-4	R3	3×10 + 10
062A-4	R4, R4 v2	3×25 + 16
073A-4	R4, R4 v2	3×35 + 16
088A-4	R5	3×50 + 25
089A-4	R4 v2	3×50 + 25
106A-4	R5	3×70 + 35
145A-4	R6	3×95 + 50
169A-4	R7	3×120 + 70
206A-4	R7	3×150 + 70
246A-4	R8	2×(3×70+35)
293A-4	R8	2×(3×95+50)
363A-4	R9	2×(3×120+70)
430A-4	R9	2×(3×150+70)

1) The cable sizing is based on max. 6 cables laid on a cable ladder side by side, ambient temperature 30 °C, PVC insulation, surface temperature 70 °C (EN 60204-1 and IEC 60364- 5-52/2001). For other conditions, size the cables according to local safety regulations, appropriate input voltage and the load current of the drive. See page 183 for the accepted cable sizes of the drive.

**Temperature:** For IEC, select a cable rated for at least 70 °C maximum permissible temperature of conductor in continuous use.

**Voltage:** 600 V AC cable is accepted for up to 500 V AC.

## Terminal and lead-through data for the control cables

### ■ IEC

Control cable lead-throughs, wire sizes and tightening torques ( $T$ ) are given below.

Frame size	Cable lead-throughs		Control cable entries and terminal sizes			
	Holes	Max cable size	+24V, DCOM, DGND, EXT. 24V terminals		DI, AI/O, AGND, RO, STO terminals	
			Wire size	$T$	Wire size	$T$
	pcs	mm	mm <sup>2</sup>	N·m	mm <sup>2</sup>	N·m
3-phase $U_n = 400\text{ V}$						
R1	3	17	0.2...2.5	0.5...0.6	0.14...1.5	0.5...0.6
R2	3	17	0.2...2.5	0.5...0.6	0.14...1.5	0.5...0.6
R3	3	17	0.2...2.5	0.5...0.6	0.14...1.5	0.5...0.6
R4, R4 v2	4	17	0.2...2.5	0.5...0.6	0.14...1.5	0.5...0.6
R5	3	17	0.2...2.5	0.5...0.6	0.14...1.5	0.5...0.6
R6	4	17	0.14...2.5	0.5...0.6	0.14...2.5	0.5...0.6
R7	4	17	0.14...2.5	0.5...0.6	0.14...2.5	0.5...0.6
R8	4	17	0.14...2.5	0.5...0.6	0.14...2.5	0.5...0.6
R9	4	17	0.14...2.5	0.5...0.6	0.14...2.5	0.5...0.6

## Electrical power network specification

### Voltage ( $U_i$ )

ACP510-01-xxxx-4 drives: Input voltage range 3~ 380...480 V AC +10%...-15%.

### Network type

Public low voltage networks. Symmetrically grounded TN-S system, IT (ungrounded), corner-grounded delta, midpoint-grounded delta and TT systems, see sections:

[IEC: When to disconnect EMC filter or ground-to-phase varistor: TN-S, IT, corner-grounded delta and midpoint-grounded delta systems \(page 92\)](#) and [Guidelines for installing the drive to a TT system \(page 94\)](#).

**Note:** Frames R4 and R5 cannot be used in corner-grounded or midpoint-grounded delta systems.

### Rated conditional short-circuit current (IEC 61800-5-1)

Maximum allowable prospective short-circuit current is 65kA when protected by fuses given in the fuse tables.

<b>Frequency (<math>f_1</math>)</b>	47 to 63 Hz. This is indicated in the type designation label as typical input frequency level f1 (50 Hz).
<b>Imbalance</b>	Max. $\pm$ 3% of nominal phase to phase input voltage
<b>Fundamental power factor (<math>\cos \phi_1</math>)</b>	0.98 (at nominal load)

---

**Minimum short-circuit power (IEC/EN 61000-3-12)**

The minimum short-circuit power  $S_{sc}$  given for each drive type for the  $R_{sc}$  (transformer short circuit ratio) value of 350.

Type ACP510-01	Input rating	Min. short circuit power		Frame size
		400 V	480 V	
	$I_1$	Ssc	Ssc	
	A	MVA	MVA	
<b>3-phase <math>U_n = 400</math> V, IEC ratings</b>				
02A7-4	2.6	0.63	0.61	R1
03A4-4	3.3	0.80	0.87	R1
04A1-4	4.0	0.97	1.02	R1
05A7-4	5.6	1.36	1.40	R1
07A3-4	7.2	1.75	1.75	R1
09A5-4	9.4	2.28	2.21	R1
12A7-4	12.6	3.06	3.49	R1
018A-4	17.0	4.12	4.07	R2
026A-4	25.0	6.06	6.69	R2
033A-4	32.0	7.76	7.86	R3
039A-4	38.0	9.21	9.89	R3
046A-4	45.0	10.91	12.80	R3
062A-4	62	15.03	15.13	R4, R4 v2
073A-4	73	17.70	18,91	R4, R4 v2
088A-4	88	21.34	22.41	R5
089A-4	89	21.6	22.4	R4 v2
106A-4	106	25.70	27.93	R5
145A-4	145	35.16	36.08	R6
169A-4	169	40.98	45.39	R7
206A-4	206	49.95	52.38	R7
246A-4	246	59.65	69.84	R8
293A-4	293	71.05	75.66	R8
363A-4	363	88.02	105.05	R9
430A-4	430	104.27	120.47	R9

## Motor connection data

<b>Motor types</b>	Asynchronous AC induction motors
<b>Short-circuit current protection (IEC/EN 1800-5-1)</b>	The drive provides solid state short circuit protection for the motor connection per IEC/EN 61800-5-1.
<b>Frequency (<math>f_2</math>)</b>	0...500 Hz. This is indicated in the type designation label as output frequency level $f_1$ (0...500 Hz).
<b>Frequency resolution</b>	0.01 Hz
<b>Current</b>	See section <a href="#">Ratings (page 167)</a> .
<b>Switching frequency</b>	2 kHz, 4 kHz (default), 8 kHz, 12 kHz

---

**Maximum recommended motor cable length** **Operational functionality and motor cable length**

The drive is designed to operate with optimum performance with the following maximum motor cable lengths.

**Note:** Conducted and radiated emissions of these motor cable lengths do not comply with EMC requirements.

Frame size	Maximum motor cable length, 4 kHz
	m
<b>Standard drive, without external options</b>	
R1	100
R2	200
R3	300
R4, R4 v2	300
R5	300
R6	300
R7	300
R8	300
R9	300

**Note:**

1. In multimotor systems, the calculated sum of all motor cable lengths must not exceed the maximum motor cable length given in the table.
2. Longer motor cables cause a motor voltage decrease which limits the available motor power. The decrease depends on the motor cable length and characteristics. Contact your local ABB representative for more information.
3. When using longer motor cables than 50 m 8 and 12 kHz switching frequencies are not allowed. With motor cable length over 100 m, disconnect EMC DC screw if applicable.
4. Acceptable motor cable length for motor manufacturers may be different. Check with specific motor manufacturer for maximum allowable distance.

### EMC compatibility and motor cable length

To comply with the European EMC Directive (standard EN 61800-3), use the following maximum motor cable lengths at 4 kHz switching frequency. See the table below.

Frame size	Maximum motor cable length, 4 kHz
	m
<b>EMC limits for Category C3<sup>1)</sup></b>	
<b>Standard drive with an internal EMC filter.</b>	
<b>See note.</b>	
R1	150
R2	150
R3	150
R4, R4 v2	150
R5	150
R6	150
R7	150
R8	150
R9	150

1) See the terms in section [Definitions \(page 197\)](#)

**Note:**

1. Radiated and conducted emissions are according to category C3 with an internal EMC filter. The internal EMC filter must be connected.

## Brake resistor connection data for frames R1...R3

**Short-circuit protection (IEC/EN 61800-5-1, IEC 61439-1)**

The brake resistor output is conditionally short-circuit proof by IEC/EN 61800-5-1. Rated conditional short-circuit current as defined in IEC 61439-1.

## Auxiliary circuit power consumption

Maximum external power supply:

Frames R1...R5: 25 W, 1.04 A at 24 V AC/DC (with option modules CMOD-01, CMOD-02)

Frames R6...R9: 36 W, 1.50 A at 24 V AC/DC (as standard, terminals 40...41)

## Efficiency

Approximately 98% at nominal power level. The efficiency is not calculated according to IEC 61800-9-2.

## Energy efficiency data (ecodesign)

Energy efficiency data according to IEC 61800-9-2 is available from the ecodesign tool (<https://ecodesign.drivesmotors.abb.com>). The drive complies with the IE efficiency class IE2.



## Ecodesign

Energy efficiency data according to IEC-61800-9-2 is available from the ecodesign tool (<https://ecodesign.drivesmotors.abb.com>).

Energy efficiency data is not provided for 1-phase 230 V drives. The drives with 1-phase input are not in the scope of the EU ecodesign requirements (Regulation EU 2019/1781).

## Protection classes for module

Degrees of protection (IEC/EN 60529)	IP20 (standard)
Overvoltage category (IEC/EN 60664-1)	III
Protective class (IEC/EN 61800-5-1)	I

## Applicable standards

The drive complies with the following standards. The compliance with the European Low Voltage Directive is verified according to standard EN 61800-5-1.

<b>EN 60204-1:2018, EN 60204-1:2006 + AC:2010</b>	<i>Safety of machinery. Electrical equipment of machines. Part 1: General requirements. Provisions for compliance:</i> The final assembler of the machine is responsible for installing <ul style="list-style-type: none"> <li>• emergency-stop device</li> <li>• supply disconnecting device.</li> </ul>
<b>IEC 60146-1-1:2009 EN 60146-1-1:2010</b>	<i>Semiconductor converters - General requirements and line commutated converters - Part 1-1: Specification of basic requirements</i>
<b>IEC 60529:1989 + AMD1:1999 + AMD2: 2013, EN 60529:1991 + A1:2000 + A2: 2013</b>	<i>Degrees of protection provided by enclosures (IP code)</i>
<b>IEC 61000-3-2:2018, EN 61000-3-2:2014</b>	<i>Electromagnetic compatibility (EMC) – Limits for harmonic current emissions (input current &gt; 16 A per phase)</i>
<b>IEC/EN 61000-3-12:2011</b>	<i>Electromagnetic compatibility (EMC) – Limits for harmonic currents produced by equipment connected to public low-voltage systems with input current input current &gt; 16 A and &lt; 75 A per phase</i>  This drive complies with the standard provided that the short-circuit power $S_{sc}$ is greater than or equal to the minimum short-circuit power given for the drive (listed for each drive type on page 302) at the interface point between the user's supply and the public system. It is the responsibility of the installer or user of the drive to ensure, by consultation with the distribution network operator if necessary, that the drive is connected only to a supply with a short-circuit power $S_{sc}$ greater than or equal to the minimum short-circuit power given for the drive.
<b>EN 61800-3:2004 + A1:2012 IEC61800-3:2017</b>	<i>Adjustable speed electrical power drive systems. Part 3: EMC requirements and specific test methods</i>
<b>EN 61800-5- 1:2007+A1:2017+A11:2021 IEC 61800-5- 1:2007+AMD1:2016</b>	<i>Adjustable speed electrical power drive systems. Part 5-1: Safety requirements – electrical, thermal and energy</i>
<b>IEC/EN 61800-9-2:2017</b>	<i>Adjustable speed electrical power drive systems. Part 9-2: Eco-design for power drive systems, motor starters, power electronics and their driven applications – Energy efficiency indicators for power drive systems and motor starters</i>
<b>IEC 60664-1:2007</b>	<i>Insulation coordination for equipment within low-voltage systems. Part 1: Principles, requirements and tests.</i>

## Ambient conditions

Environmental limits for the drive are given below. The drive is to be used in a heated, indoor, controlled environment. All printed circuit boards are conformal coated.

	<b>Operation</b> installed for stationary use	<b>Storage</b> in the package	<b>Transportation</b> in the package
<b>Installation site altitude</b>	<ul style="list-style-type: none"> <li>• 0...4000 m above sea level 1)</li> <li>• 0...2000 m above sea level 2)</li> </ul> Output derated above 1000 m, see section <a href="#">Altitude de-rating (page 171)</a> .	-	-
<b>Air temperature</b>	-15...+50 °C. 0...-15 °C: No frost allowed. See section <a href="#">Ratings (page 167)</a> .	-40...+70 °C	-40...+70 °C
<b>Relative humidity</b>	5...95%	Max. 95%	Max. 95%
	No condensation allowed. Maximum allowed relative humidity is 60% in the presence of corrosive gases.		
<b>Contamination levels</b> (IEC 60721-3-x)	IEC 60721-3-3: 2002: Classification of environmental conditions - Part 3-3: Classification of groups of environmental parameters and their severities - Stationary use of weather protected locations	IEC 60721-3-1: 1997	IEC 60721-3-2: 1997
Solid particles	Class 3S2. No conductive dust allowed.	Class 1S3 (packing must support this, otherwise 1S2)	Class 2S2
<b>Pollution degree</b> (IEC/EN 61800-5-1)	Pollution degree 2	-	-

<b>Atmospheric pressure</b>	70...106 kPa 0.7...1.05 atmospheres	70...106 kPa 0.7...1.05 atmospheres	60...106 kPa 0.6...1.05 atmospheres										
<b>Vibration(IEC 60068-2)</b>	Max. 1 mm (5...13.2 Hz), max. 7 m/s <sup>2</sup> (13.2...100 Hz) sinusoidal	-	-										
<b>Vibration(ISTA)</b>	-	<u>R1...R4</u> (ISTA 1A): Displacement, 25 mm peak to peak, 14200 vibratory impacts <u>R5...R9</u> (ISTA 3E): Random, overall Grms level of 0.52											
<b>Shock/Drop (ISTA)</b>	Not allowed	<u>R1...R4</u> (ISTA 1A): Drop, 6 faces, 3 edges and 1 corner <table border="1" data-bbox="632 558 1036 758"> <thead> <tr> <th>Weight range</th> <th>mm</th> </tr> </thead> <tbody> <tr> <td>0...10 kg</td> <td>760</td> </tr> <tr> <td>10...19 kg</td> <td>610</td> </tr> <tr> <td>19...28 kg</td> <td>460</td> </tr> <tr> <td>28...41 kg</td> <td>340</td> </tr> </tbody> </table> <u>R5...R9</u> (ISTA 3E): Shock, incline impact: 1.1 m/s Shock, rotational edge drop: 200 mm		Weight range	mm	0...10 kg	760	10...19 kg	610	19...28 kg	460	28...41 kg	340
Weight range	mm												
0...10 kg	760												
10...19 kg	610												
19...28 kg	460												
28...41 kg	340												

- 1) For symmetrically grounded TN-S systems, TT systems, and ungrounded or symmetrically high-resistance grounded IT systems. See also section [Limiting relay output maximum voltages at high installation altitudes \(page 86\)](#).
- 2) For corner-grounded delta systems, midpoint-grounded delta systems and corner-grounded (via high resistance) IT systems.

**Note:** There are special considerations in corner-grounded installations above 2000 m. Contact your local ABB representative for further information.

## Storage conditions

Store the drive in humidity controlled enclosed environments. Keep the drive in its package.





## Colors

### Drive enclosure

- NCS 1502-Y (RAL 9002 / PMS 1C Cool Grey), RAL 9002 and PMS 425 C.
- NCS 1502-Y

## Markings

These markings are attached to the drive:

	<p>CE mark Product complies with the applicable European Union legislation. For fulfilling the EMC requirements, see the additional information concerning the drive EMC compliance (IEC/EN 61800-3).</p>
	<p>TÜV Safety Approved mark (functional safety) Product contains Safe torque off and possibly other (optional) safety functions which are certified by TÜV according to the relevant functional safety standards. Applicable to drives and inverters; not applicable to supply, brake or DC/DC converter units or modules.</p>
	<p>China RoHS Mark <i>The People's Republic of China Electronic Industry Standard (SJ/T 11364-2014)</i> specifies the marking requirements for hazardous substances in electronic and electrical products. The green mark is attached to the drive to verify that it does not contain toxic and hazardous substances or elements above the maximum concentration values, and that it is an environmentally-friendly product which can be recycled and reused.</p>
	<p>WEEE mark At the end of life the product should enter the recycling system at an appropriate collection point and not placed in the normal waste stream.</p>

## CE marking

A CE mark is attached to the drive to verify that the drive follows the provisions of the European Low Voltage, EMC and RoHS and WEEE Directives.

The CE marking also verifies that the drive, in regard to its safety functions (such as Safe torque off), conforms with the Machinery Directive as a safety component.

### ■ Compliance with the European Low Voltage Directive

The compliance with the European Low Voltage Directive has been verified according to standard EN 61800-5-1:2007. The declaration of conformity (3AXD10002160723) is available on the Internet. See section *Document library on the Internet* on the inside of the back cover.

### ■ Compliance with the European EMC Directive

The EMC Directive defines the requirements for immunity and emissions of electrical equipment used within the European Union. The EMC product standard

(EN 61800- 3:2004 + A1:2012) covers requirements stated for drives. See section [Compliance with the EN 61800-3](#) below. The declaration of conformity (3AXD10002160723) is available on the Internet. See section *Document library on the Internet* on the inside of the back cover.

#### ■ **Compliance with the European ROHS II Directive 2011/65/EU**

The RoHS II Directive defines the restriction of the use of certain hazardous substances in electrical and electronic equipment. The declaration of conformity (3AXD10002160723) is available on the Internet. See section *Document library on the Internet* on the inside of the back cover.

#### ■ **Compliance with the European WEEE Directive 2002/96/EC**

The WEEE Directive defines the regulated disposal and recycling of electric and electrical equipment.

#### ■ **Compliance with the European Machinery Directive 2006/42/EC 2nd Edition – June 2010**

The drive is a machinery component that can be integrated into a wide range of machinery categories as specified in European Commission's *Guide to application of the Machinery Directive 2006/42/EC 2nd Edition – June 2010*. See chapter [The Safe torque off function \(page 219\)](#).

#### **Validating the operation of the Safe torque off function**

See chapter [The Safe torque off function \(page 219\)](#).

## **Compliance with the EN 61800-3**

### ■ **Definitions**

EMC stands for Electromagnetic Compatibility. It is the ability of electrical/electronic equipment to operate without problems within an electromagnetic environment. Likewise, the equipment must not disturb or interfere with any other product or system within its locality.

First environment includes establishments connected to a low-voltage network which supplies buildings used for domestic purposes.

Second environment includes establishments connected to a network not supplying domestic premises.

Drive of category C1: drive of rated voltage less than 1000 V and intended for use in the first environment.

Drive of category C2: drive of rated voltage less than 1000 V and intended to be installed and started up only by a professional when used in the first environment.

**Note:** A professional is a person or organization having necessary skills in installing and/or starting up power drive systems, including their EMC aspects.

Drive of category C3: drive of rated voltage less than 1000 V and intended for use in the second environment and not intended for use in the first environment.

Drive of category C4: drive of rated voltage equal to or above 1000 V, or rated current equal to or above 400 A, or intended for use in complex systems in the second environment.

### ■ Category C1

The emission limits are complied with the following provisions:

1. The optional EMC C1 filter is selected according to the documentation and installed as specified in the EMC C1 filter manual.
2. The motor and control cables are selected as specified in this manual.
3. The drive is installed according to the instructions given in this manual.
4. The maximum motor cable length with 2 kHz switching frequency is 10 m.



#### **WARNING!**

In a domestic environment, this product may cause radio interference, in which case supplementary mitigation measures may be required.

---

### ■ Category C2

The emission limits are complied with the following provisions:

1. The motor and control cables are selected as specified in this manual.
2. The drive is installed according to the instructions given in this manual.
3. For the maximum motor cable length with 4 kHz switching frequency, see **Maximum recommended motor cable length** (page 190).



#### **WARNING!**

The drive may cause radio interference if used in residential or domestic environment. The user is required to take measures to prevent interference, in association to the requirements for the CE compliance listed above, if necessary.

---

**Note:** Do not install a drive with the EMC filter connected to a system that the filter is not suitable for. This can cause danger, or damage the drive.

**Note:** Do not install the drive with the ground-to-phase varistor connected to a system that the varistor is not suitable for. It can cause damage to the varistor circuit.

---

If you install the drive to any other system than symmetrically grounded TN-S system, you may need to disconnect the EMC filter or the ground-to-phase varistor. See sections:

[IEC: Grounding system compatibility check \(page 91\)](#)

### ■ Category C3

The drive complies with the standard with the following provisions:

1. The motor and control cables are selected as specified in this manual.
2. The drive is installed according to the instructions given in this manual.
3. For the maximum motor cable length with 4 kHz switching frequency, see page [Maximum recommended motor cable length \(page 190\)](#)



#### **WARNING!**

A drive of category C3 is not intended to be used on a low-voltage public network which supplies domestic premises. Radio frequency interference is expected if the drive is used on such a network.

### ■ Category C4

The drive complies with the C4 category with these provisions:

1. It is made sure that no excessive emission is propagated to neighboring low-voltage networks. In some cases, the natural suppression in transformers and cables is sufficient. If in doubt, a supply transformer with static screening between the primary and secondary windings can be used.

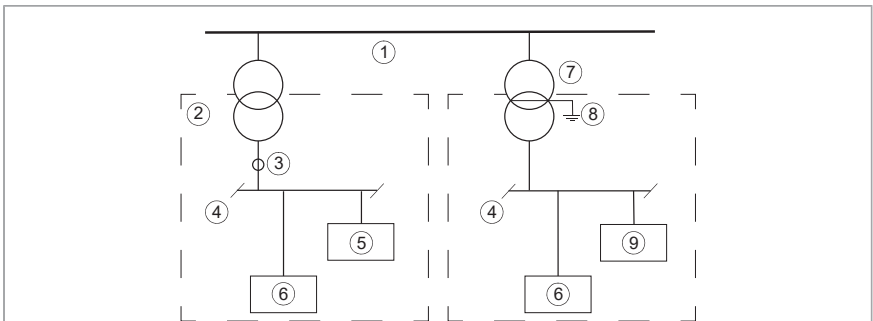

1	Medium voltage network	6	Equipment
2	Neighboring network	7	Supply transformer
3	Point of measurement	8	Static screen
4	Low voltage	9	Drive
5	Equipment (victim)	-	-

2. An EMC plan for preventing disturbances is drawn up for the installation. A template is available in [Technical guide No. 3 EMC compliant installation and configuration for a power drive system \(3AFE61348280 \[English\]\)](#).
3. The motor and control cables are selected, and routed according to the electrical planning guidelines of the drive. The EMC recommendations are obeyed.
4. The drive is installed according to its installation instructions. The EMC recommendations are obeyed.



**WARNING!**

A drive of category C4 is not intended to be used on a low-voltage public network which supplies domestic premises. Radio frequency interference is expected if the drive is used on such a network.

---

## Disclaimers

### ■ Generic disclaimer

The manufacturer shall have no obligation with respect to any product which (i) has been improperly repaired or altered; (ii) has been subjected to misuse, negligence or accident; (iii) has been used in a manner contrary to the manufacturer's instructions; or (iv) has failed as a result of ordinary wear and tear.

### ■ Cyber security disclaimer

This product is designed to be connected to and to communicate information and data via a network interface. It is Customer's sole responsibility to provide and continuously ensure a secure connection between the product and Customer network or any other network (as the case may be). Customer shall establish and maintain any appropriate measures (such as but not limited to the installation of firewalls, application of authentication measures, encryption of data, installation of anti-virus programs, etc.) to protect the product, the network, its system and the interface against any kind of security breaches, unauthorized access, interference, intrusion, leakage and/or theft of data or information.

ABB and its affiliates are not liable for damages and/or losses related to such security breaches, any unauthorized access, interference, intrusion, leakage and/or theft of data or information.

---

# 11

## Dimension drawings

---

### Contents of this chapter

This chapter shows the dimension drawings of the ACP510-01.

**Note:** The dimensions are given in millimeters.

# Frame R1, IP20

Frame R1, IP20

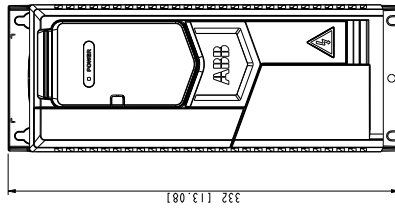
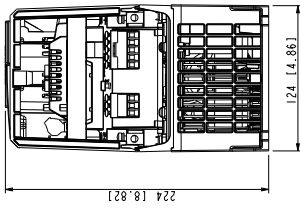
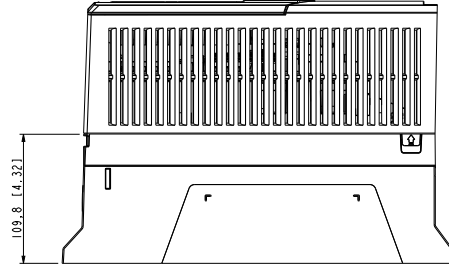
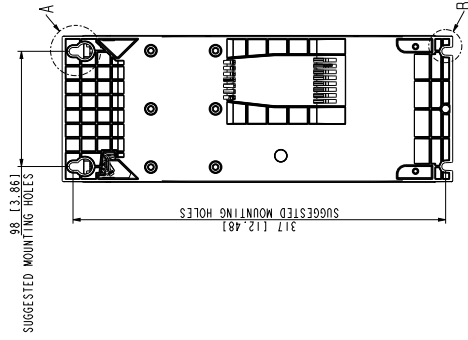
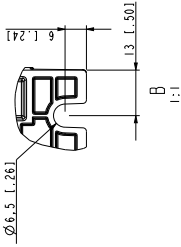
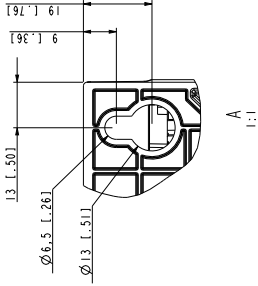

Frame R2, IP20

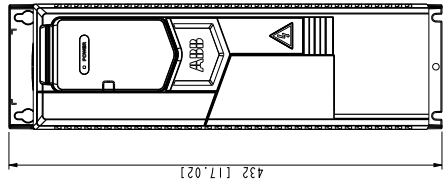
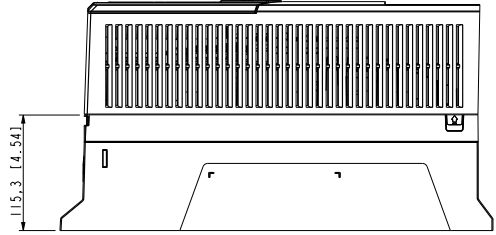
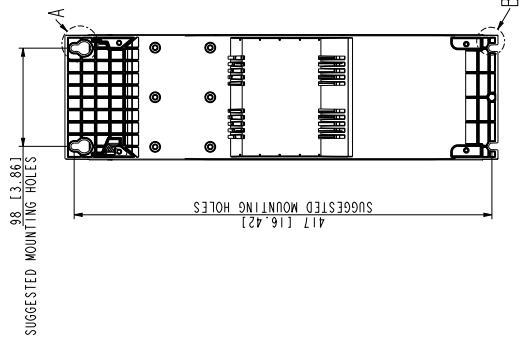
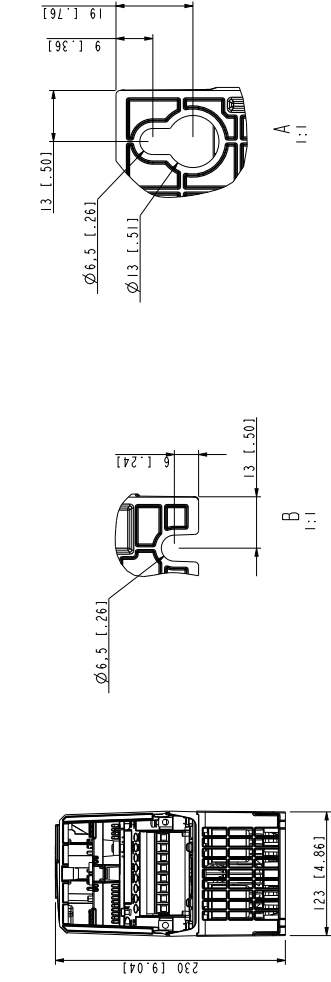

Frame R2, IP20

# Frame R3, IP20

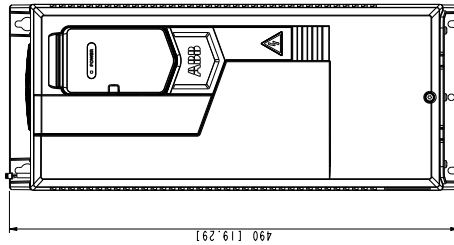
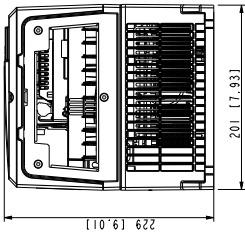
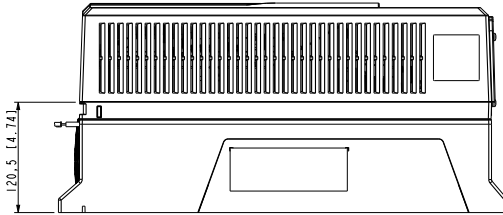
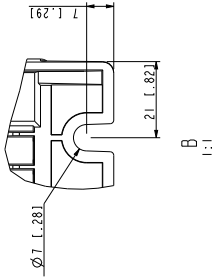
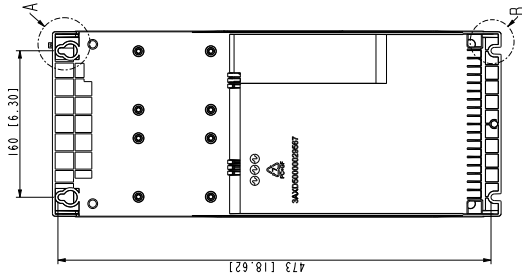
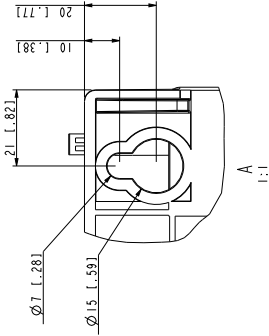

# Frame R4, IP20

Frame R4, IP20

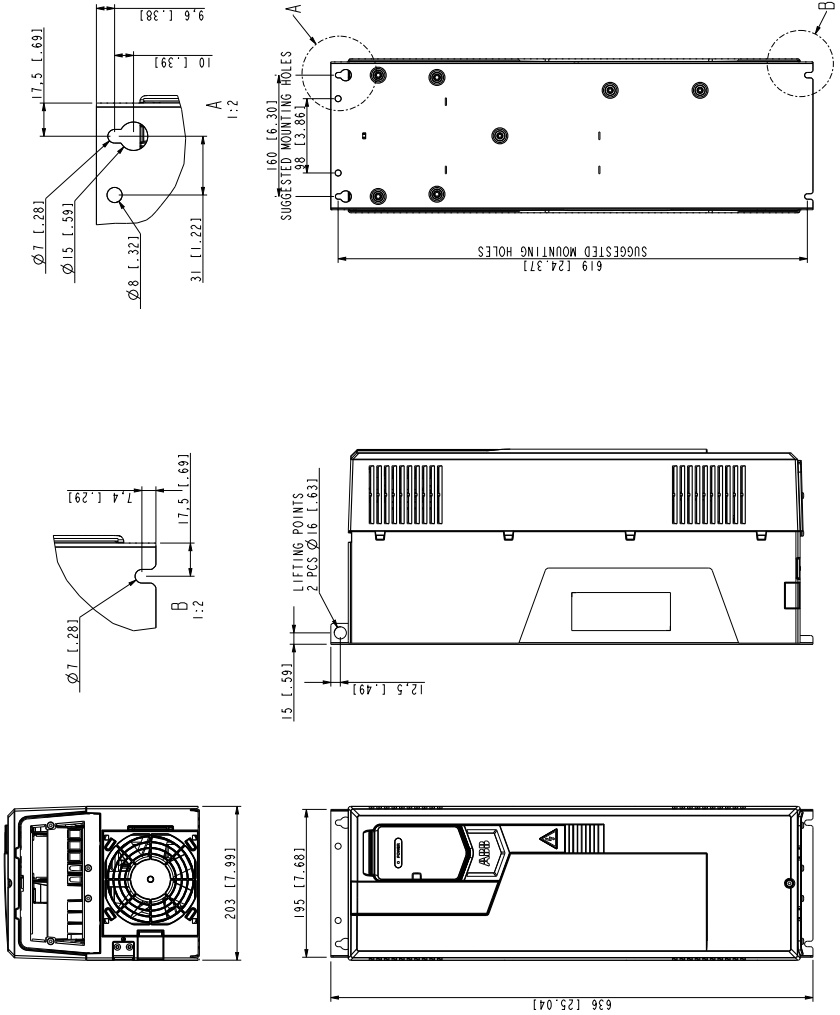

# Frame R5, IP20

Frame R5, IP20

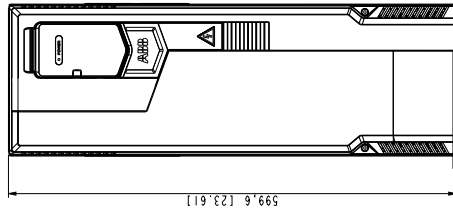
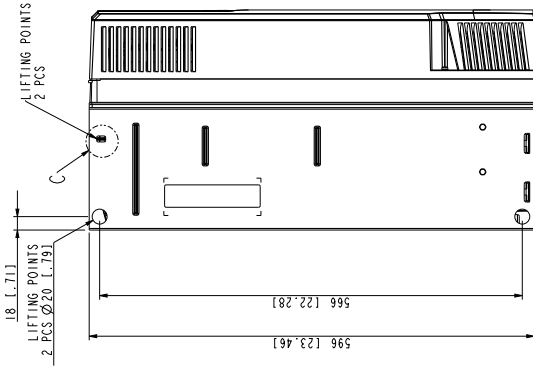
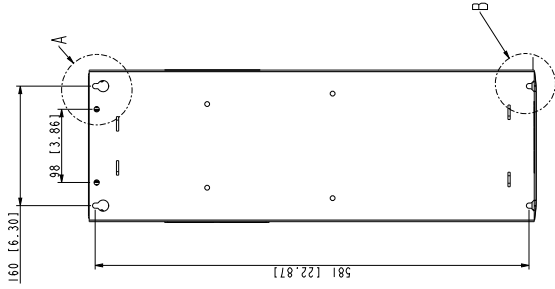
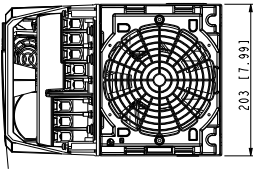
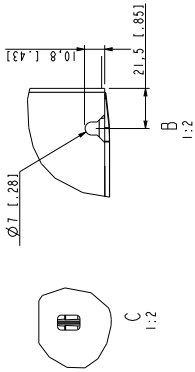
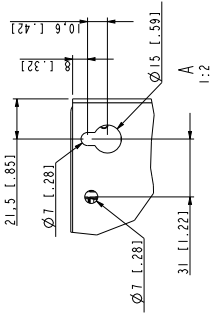

# Frame R6, IP20

Frame R6, IP20

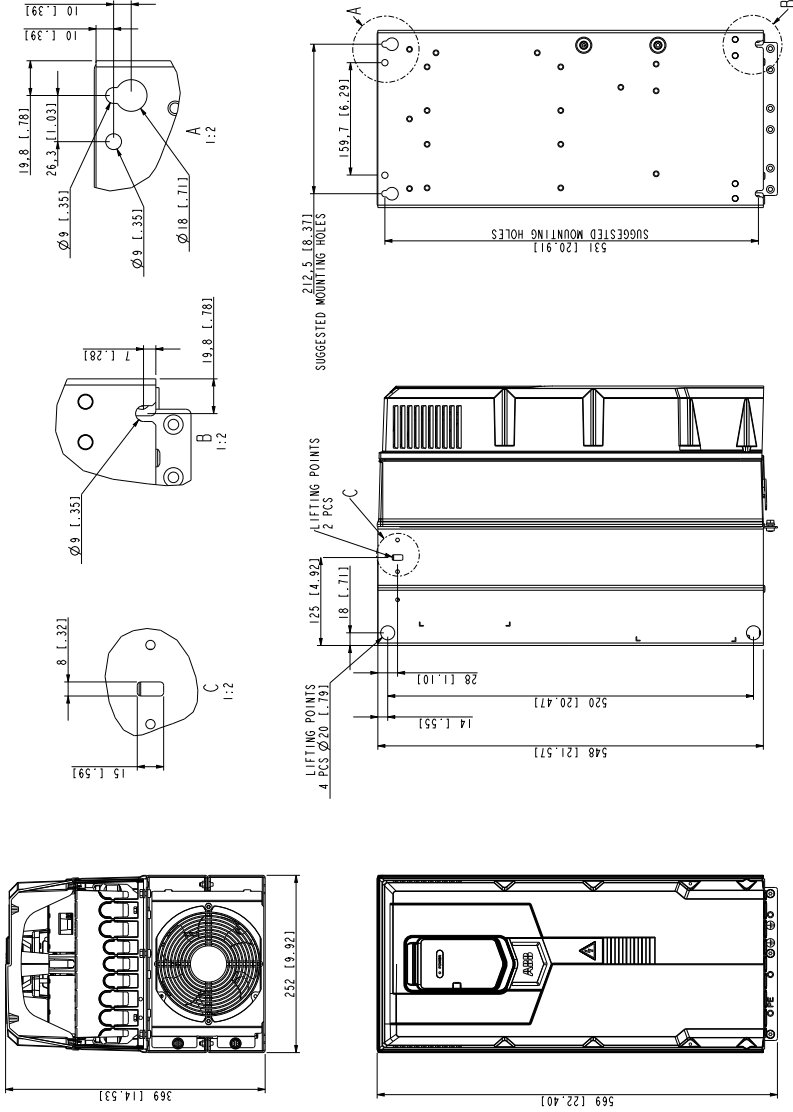

Frame R7, IP20

Frame R7, IP20

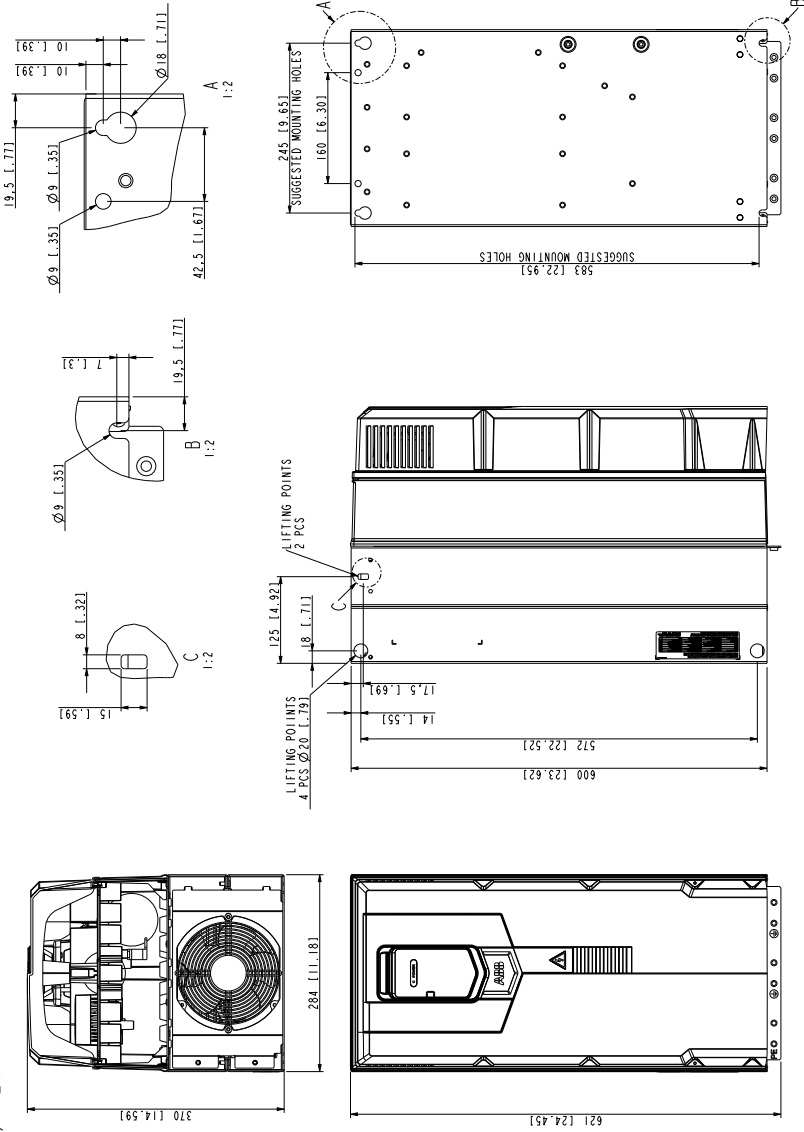

# Frame R8, IP20

Frame R8, IP20

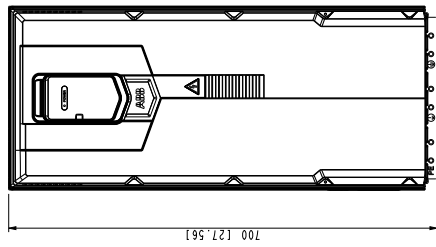
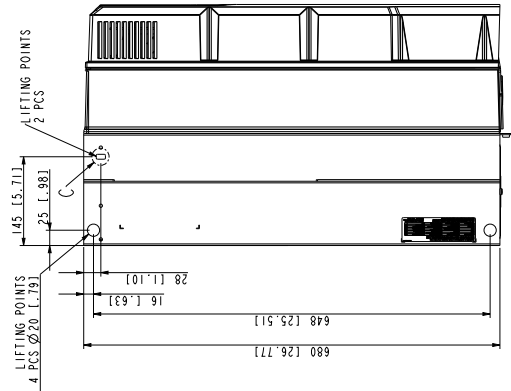
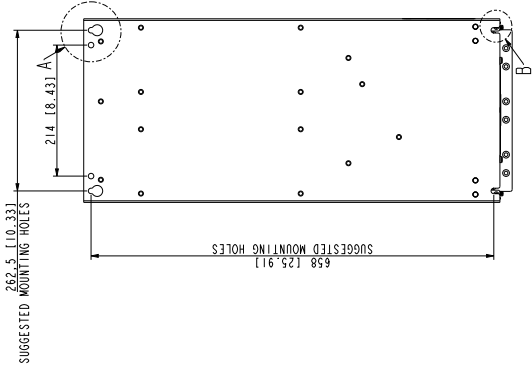
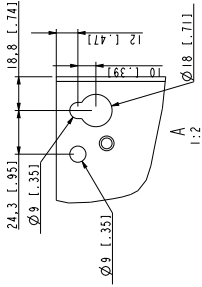
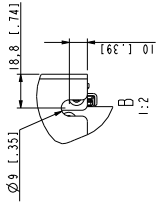
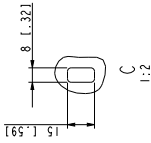
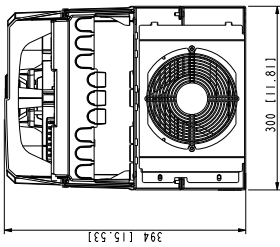

Frame R9, IP20

Frame R9, IP20

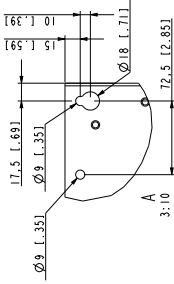
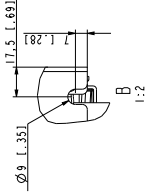
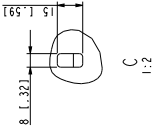
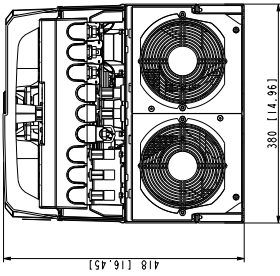

LIFTING POINTS  
4 PCS  $\varnothing 22$  [1.81]

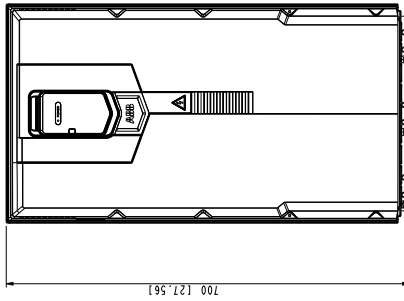
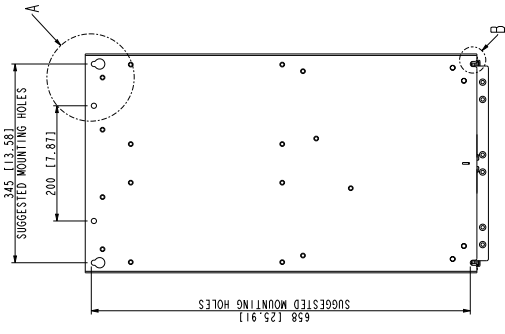
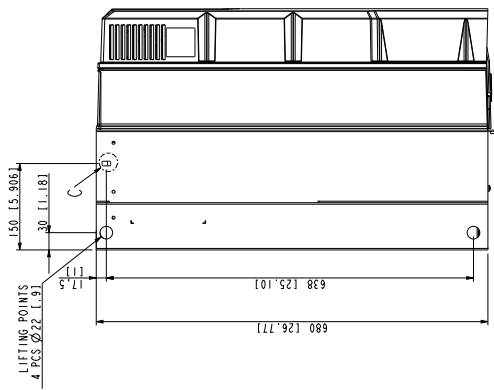

# 12

## Resistor braking

---

### Contents of this chapter

This chapter contains information and instructions on resistor braking, brake choppers and brake resistors.

### Operation principle and hardware description

The brake chopper handles the energy generated by a decelerating motor. The chopper connects the brake resistor to the intermediate DC circuit whenever the voltage in the circuit exceeds the limit defined by the control program. Energy consumption by the resistor losses lowers the voltage until the resistor can be disconnected.

### Resistor braking, frames R1...R3

#### ■ Planning the braking system

#### Selecting the brake resistor

Frames R1...R3 have an built-in brake chopper as standard equipment. The brake resistor is selected using the table and equations presented in this section.

1. Determine the required maximum braking power  $P_{Rmax}$  for the application.  $P_{Rmax}$  must be smaller than  $P_{BRmax}$  given in the table on page 212 for the used drive type.
  2. Calculate resistance  $R$  with Equation 1.
  3. Calculate energy  $E_{Rpulse}$  with Equation 2.
-

212 Resistor braking

4. Select the resistor so that the following conditions are met:
- The rated power of the resistor must be greater than or equal to  $P_{Rmax}$ .
  - Resistance  $R$  must be between  $R_{min}$  and  $R_{max}$  given in the table for the used drive type.
  - The resistor must be able to dissipate energy  $E_{Rpulse}$  during the braking cycle  $T$ .

Equations for selecting the resistor:

Eq. 1.  $U_N = 400V : R = \frac{450000}{P_{Rmax}}$

$U_N = 480V : R = \frac{615000}{P_{Rmax}}$

Eq. 2.  $E_{Rpulse} = P_{Rmax} \cdot t_{on}$

Eq. 3.  $P_{Rave} = P_{Rmax} \cdot \frac{t_{on}}{T}$

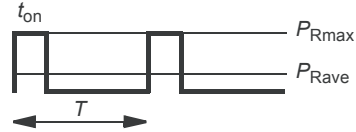

For conversion, use 1 hp = 746 W.

where

- $R$  = calculated brake resistor value (ohm). Make sure that:  $R_{min} < R < R_{max}$
- $P_{Rmax}$  = maximum power during the braking cycle (W)
- $P_{Rave}$  = average power during the braking cycle (W)
- $E_{Rpulse}$  = energy conducted into the resistor during a single braking pulse (J)
- $t_{on}$  = length of the braking pulse (s)
- $T$  = length of the braking cycle (s).

The tables below show reference resistor types for the maximum braking power.

IEC

Type ACP510-01-	$R_{min}$	$R_{max}$	$P_{BRmax}$	Reference resistor types
	ohm	ohm	kW	
<b>3-phase <math>U_n = 400 V</math></b>				
02A7-4	52	864	0.6	Danotherm CBH 360 C T 406 210R
03A4-4	52	582	0.9	Danotherm CBH 360 C T 406 210R
04A1-4	52	392	1.4	Danotherm CBH 360 C T 406 210R
05A7-4	52	279	2.0	Danotherm CBH 360 C T 406 210R
07A3-4	52	191	2.9	Danotherm CBR-V 330 D T 406 78R UL
09A5-4	52	140	3.9	Danotherm CBR-V 330 D T 406 78R UL

Type ACP510-01-	$R_{\min}$	$R_{\max}$	$P_{BR\max}$	Reference resistor types
	ohm	ohm	kW	
12A7-4	52	104	5.3	Danotherm CBR-V 330 D T 406 78R UL
018A-4	31	75	7.3	Danotherm CBR-V 560 D HT 406 39R UL
026A-4	22	52	10	Danotherm CBR-V 560 D HT 406 39R UL
033A-4	16	37	15	Danotherm CBT-H 560 D HT 406 19R
039A-4	10	27	20	Danotherm CBT-H 760 D HT 406 16R
046A-4	10	22	25	Danotherm CBT-H 760 D HT 406 16R

### Symbols

- $R_{\min}$  = minimum allowed brake resistor that can be connected to the brake chopper
- $R_{\max}$  = maximum allowed brake resistor that allows  $P_{BR\max}$
- $P_{BR\max}$  = maximum braking capacity of the drive, must exceed the desired braking power.



### WARNING!

Do not use a brake resistor with a resistance below the minimum value specified for the particular drive. The drive and the internal chopper are not able to handle the overcurrent caused by the low resistance.

### Selecting and routing the brake resistor cables

Use a shielded cable with the conductor size specified in section Terminal and lead-through data for the power cables on page [Terminal and lead-through data for the power cables \(page 183\)](#).

### Minimizing electromagnetic interference

Follow these rules in order to minimize electromagnetic interference caused by the rapid current changes in the resistor cables:

- Install the cables away from other cable routes.
- Avoid long parallel runs with other cables. The minimum parallel cabling separation distance should be 0.3 meters.
- Cross the other cables at right angles.
- Keep the cable as short as possible in order to minimize the radiated emissions and stress on chopper IGBTs. The longer the cable the higher the radiated emissions, inductive load and voltage peaks over the IGBT semiconductors of the brake chopper.

**Note:** ABB has not verified that the EMC requirements are fulfilled with external user-defined brake resistors and cabling. The EMC compliance of the complete installation must be considered by the customer.

### Maximum cable length

The maximum length of the resistor cable(s) is 10 m

### **Placing the brake resistor**

Install the resistors outside the drive in a place where they will cool.

Arrange the cooling of the resistor in a way that:

- no danger of overheating is caused to the resistor or nearby materials
- the temperature of the room the resistor is located in does not exceed the allowed maximum.

Supply the resistor with cooling air/water according to the resistor manufacturer's instructions.



### **WARNING!**

The materials near the brake resistor must be non-flammable. The surface temperature of the resistor is high. Air flowing from the resistor is of hundreds of degrees Celsius. If the exhaust vents are connected to a ventilation system, make sure that the material withstands high temperatures. Protect the resistor against contact.

---

### **Protecting the system in brake circuit fault situations**

#### Protecting the system in cable and brake resistor short-circuit situations

The drive input fuses will also protect the resistor cable when it is identical with the input power cable.

#### Protecting the system against thermal overload

The drive has a brake thermal model which protects the brake resistor against overload. ABB recommends to enable the thermal model at start up.

ABB recommends to equip the drive with a main contactor for safety reasons even when you have enabled the resistor thermal model. Wire the contactor so that it opens in case the resistor overheats. This is essential for safety since the drive will not otherwise be able to interrupt the main supply if the chopper remains conductive in a fault situation. An example wiring diagram is shown below. ABB recommends that you use resistors equipped with a thermal switch (1) inside the resistor assembly. The switch indicates overtemperature.

---

ABB recommends that you also wire the thermal switch to a digital input of the drive, and configure the input to cause a fault trip at resistor overtemperature indication.

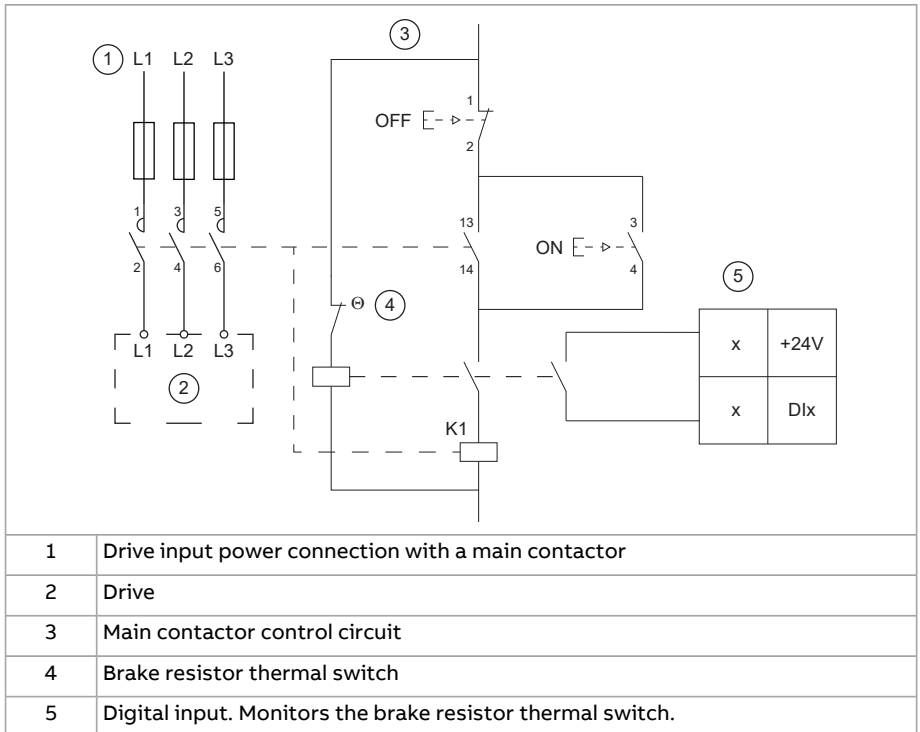

### ■ Mechanical installation

All brake resistors must be installed outside the drive. Follow the resistor manufacturer's instructions.

### ■ Electrical installation

#### Checking the insulation of the assembly

Follow the instructions given in section [Brake resistor assembly for R1...R3 \(page 91\)](#).

#### Connection diagram

See section [Connection diagram \(page 99\) \(IEC\)](#).

#### Connection procedure

See section

Connect the thermal switch of the brake resistor as described in [Protecting the system against thermal overload \(page 214\)](#).

■ **Start-up**

**Start-up**

---

 **WARNING!** Make sure that there is sufficient ventilation. New brake resistors can have a protective grease coating. When the resistor warms up for the first time, the grease burns off and can produce some smoke.

---

Set the following parameters

- Set parameter 30.30 Overvoltage control to disable.
- Set parameter 31.01 External event 1 source to point to the digital input where the thermal switch of the brake resistor is wired.
- Set parameter 31.02 External event 1 type to Fault.
- Set parameter 43.06 Brake chopper function to Enable. If you select Enabled with thermal model, set also the brake resistor overload protection parameters 43.08 and 43.09 according to the application.
- Check the resistance value of parameter 43.10 Brake resistance.

With these parameter settings, the drive stops by coasting on brake resistor overtemperature.

---

 **WARNING!** If you disable the brake chopper by parameter, also disconnect the brake resistor cable from the drive. Otherwise, there is a risk of resistor overheating and damage.

---

## Resistor braking, frames R4...R9

■ **Planning the braking system**

Frames R4...R9 need external brake choppers and resistors. The table below lists suitable choppers and resistors.

**IEC**

Type ACP510-01-	Brake chop- per	R <sub>min</sub>	R <sub>max</sub>	P <sub>BRmax</sub>	Reference resistor types <sup>1)</sup>
		ohm	ohm	kW	
3-phase U <sub>n</sub> = 400 V (380...415 V,)					

Type ACP510-01-	Brake chop- per	$R_{\min}$	$R_{\max}$	$P_{BR\max}$	Reference resistor types <sup>1)</sup>
		ohm	ohm	kW	
062A-4	ACS-BRK-D	7.8	18.1	30	Built in with the brake chopper
073A-4	ACS-BRK-D	7.8	13.1	42	Built in with the brake chopper
088A-4	ACS-BRK-D	7.8	10.7	51	Built in with the brake chopper
106A-4	NBRA-658	1.3	8.7	63	SAFUR125F500
145A-4	NBRA-658	1.3	7.1	77	SAFUR125F500
169A-4	NBRA-658	1.3	5.2	105	SAFUR200F500
206A-4	NBRA-658	1.3	4.3	126	SAFUR200F500
246A-4	NBRA-658	1.3	3.5	156	2xSAFUR125F500
293A-4	NBRA-658	1.3	2.9	187	2xSAFUR210F575
363A-4	NBRA-659	0.7	2.4	227	2xSAFUR200F500
430A-4	NBRA-659	0.7	1.9	284	2xSAFUR200F500

<sup>1)</sup> Other resistors can be used if they meet the minimum resistance value and required power values.

Symbols	
$R_{\min}$	= minimum allowed brake resistor that can be connected to the brake chopper
$R_{\max}$	= maximum allowed brake resistor that allows $P_{BR\max}$
$P_{BR\max}$	= maximum braking capacity of the drive, must exceed the desired braking power.



### WARNING!

Do not use a brake resistor with a resistance below the minimum value specified for the particular drive. The drive and the internal chopper are not able to handle the overcurrent caused by the low resistance.

## ■ Parameter settings for external braking chopper and resistor

Disable the overvoltage control of the drive with parameter 30.30 Overvoltage control.

Disable parameter 43.06 Braking chopper function as parameter group 43 Brake chopper is used for internal braking chopper and resistor only.

## 218 Resistor braking

For more information, see *NBRA-6xx Braking Choppers Installation and start-up guide* (3AFY58920541 [English]) and *ACS-BRK Brake Units Installation and start-up guide* (3AFY61514309 [English]).

# 13

## The Safe torque off function

---

### Contents of this chapter

This chapter describes the Safe torque off (STO) function of the drive and gives instructions for its use.

### Description

The Safe torque off function can be used, for example, as the final actuator device of safety circuits that stop the drive in case of danger (such as an emergency stop circuit). Another typical application is a prevention of unexpected start-up function that enables short-time maintenance operations like cleaning or work on non-electrical parts of the machinery without switching off the power supply to the drive.

**Note:** The Safe torque off function will not disconnect the drive. Refer to the warning in [Use \(page 230\)](#)

When activated, the Safe torque off function disables the control voltage for the power semiconductors of the drive output stage (A, see the diagrams below), thus preventing the drive from generating the torque required to rotate the motor. If the motor is running when Safe torque off is activated, it coasts to a stop.

The Safe torque off function has a redundant architecture, that is, both channels must be used in the safety function implementation. The safety data given in this manual is calculated for redundant use, and does not apply if both channels are not used.

---

The Safe torque off function complies with these standards:

Standard	Name
EN 60204-1:2018 IEC 60204-1:2021	<i>Safety of machinery – Electrical equipment of machines – Part 1: General requirements</i>
IEC 61000-6-7:2014	Electromagnetic compatibility (EMC) – Part 6-7: Generic standards – Immunity requirements for equipment intended to perform functions in a safety-related system (functional safety) in industrial locations
IEC 61326-3-1:2017	<i>Electrical equipment for measurement, control and laboratory use – EMC requirements – Part 3-1: Immunity requirements for safety-related systems and for equipment intended to perform safety-related functions (functional safety) – General industrial applications</i>
IEC 61508-1:2010	<i>Functional safety of electrical/electronic/programmable electronic safety-related systems – Part 1: General requirements</i>
IEC 61508-2:2010	<i>Functional safety of electrical/electronic/programmable electronic safety-related systems – Part 2: Requirements for electrical/electronic/programmable electronic safety-related systems</i>
IEC 61511-1: 2016+AMD1:2017 CSV	<i>Functional safety – Safety instrumented systems for the process industry sector</i>
IEC 61800-5-2: 2016 EN 61800-5-2: 2007	<i>Adjustable speed electrical power drive systems – Part 5-2: Safety requirements – Functional</i>
EN IEC 62061:2021	<i>Safety of machinery – Functional safety of safety-related electrical, electronic and programmable electronic control systems</i>
EN ISO 13849-1:2023	<i>Safety of machinery – Safety-related parts of control systems – Part 1: General principles for design</i>
EN ISO 13849-2:2012	<i>Safety of machinery – Safety-related parts of control systems – Part 2: Validation</i>

The function also corresponds to Prevention of unexpected start-up as specified by EN ISO 14118:2018 (ISO 14118:2017), and Uncontrolled stop (stop category 0) as specified in EN 60204-1.

■ **Compliance with the European Machinery Directive**

The Declarations of conformity are shown at the end of this chapter.

## Wiring

For the electrical specifications of the STO connection, see the technical data of the control unit.

### ■ Connection principle

#### Single ACP510-01 drive, internal power supply

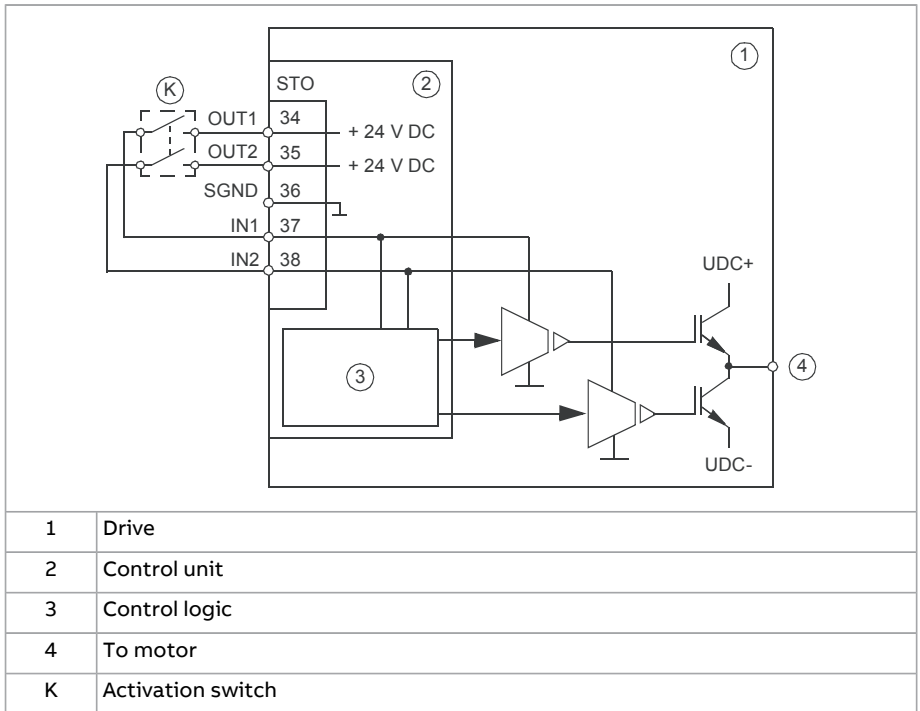

**Single ACP510-01 drive, external power supply**

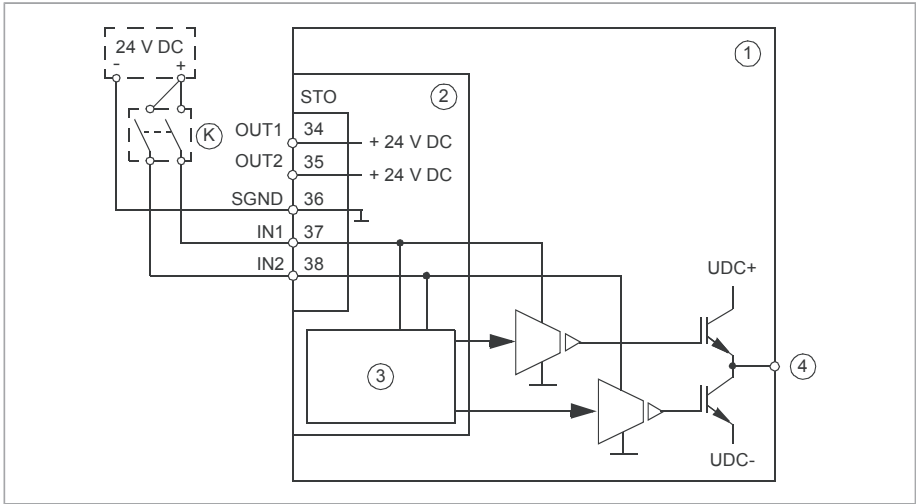

1	Drive
2	Control unit
3	Control logic
4	To motor
K	Activation switch

■ **Wiring examples**

**Single ACP510-01 drive, internal power supply**

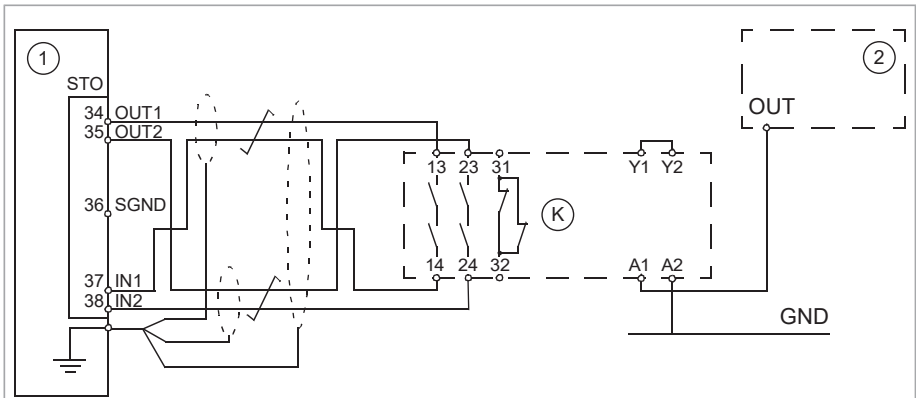

1	Drive
---	-------



**Multiple ACP510-01 drives, internal power supply**

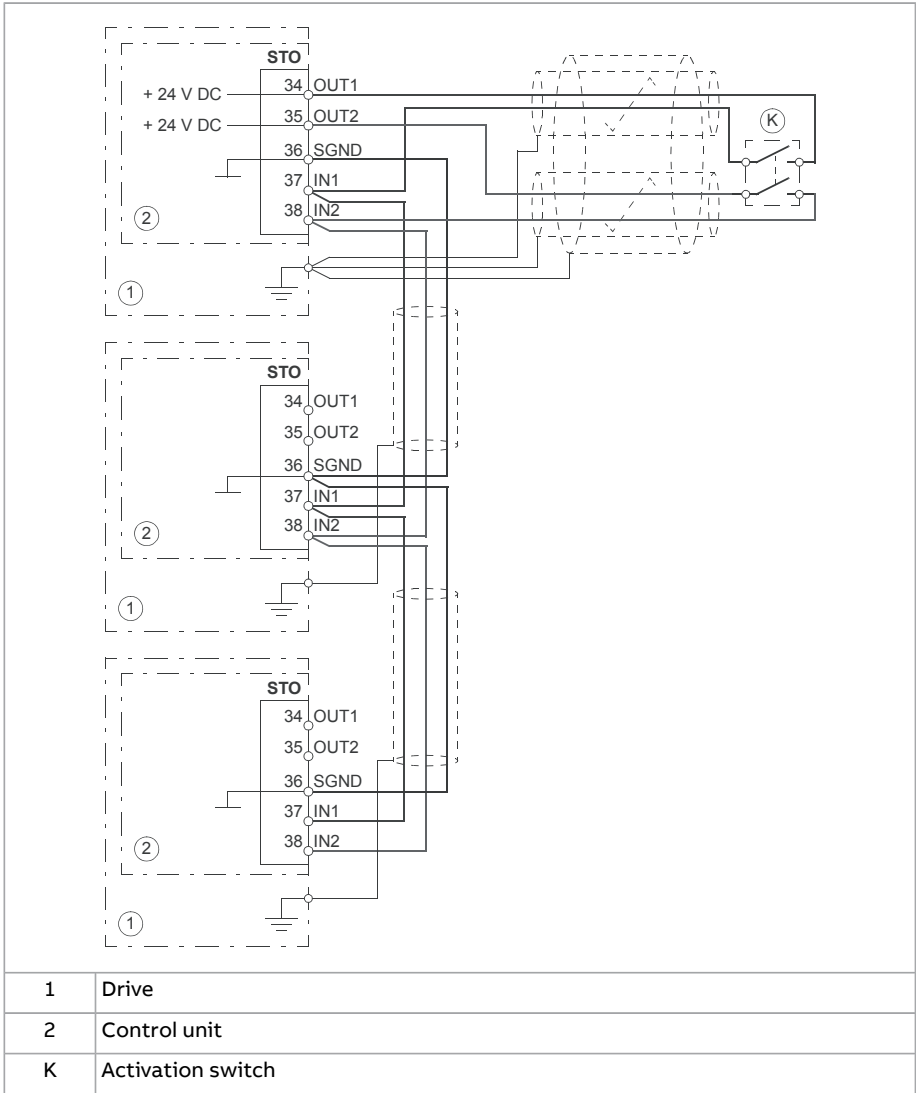

Multiple ACP510-01 drives, external power supply

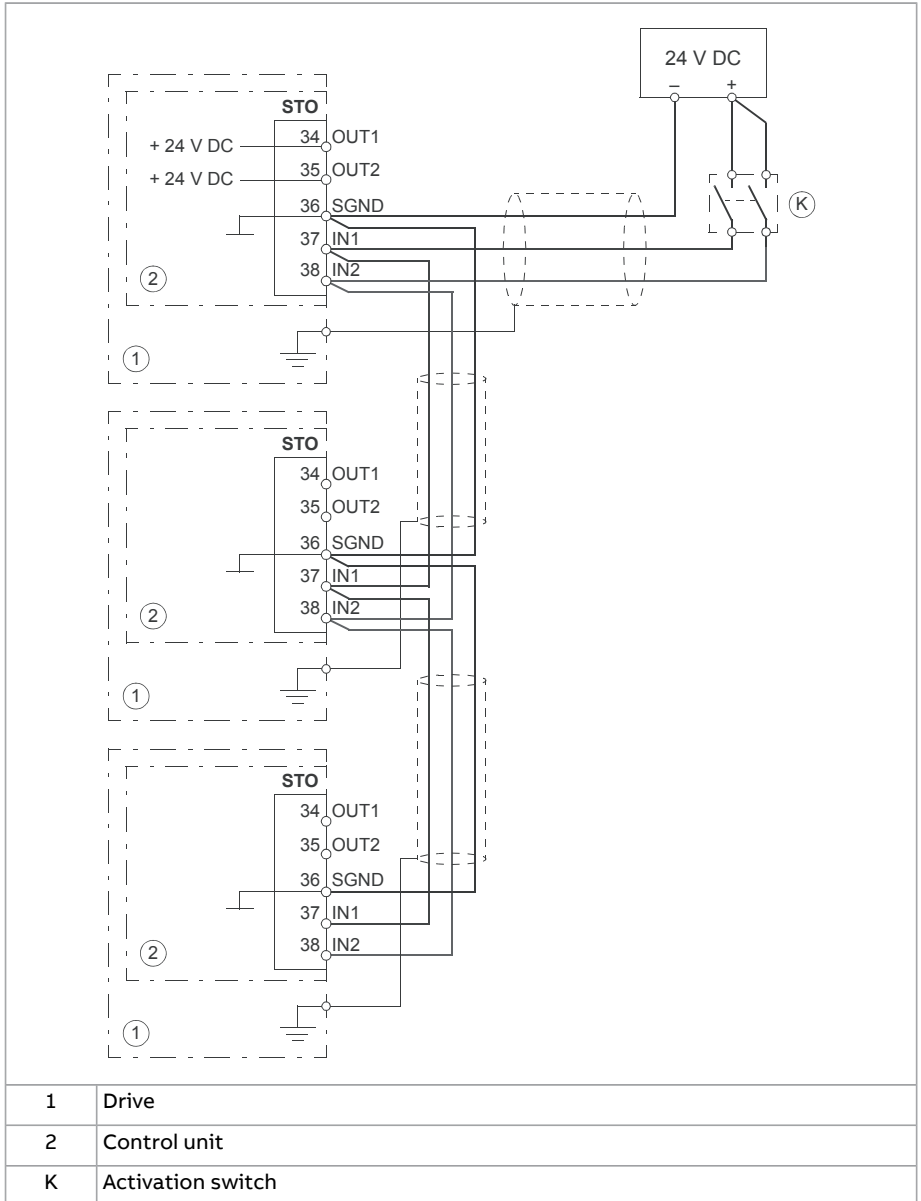

## ■ Activation switch

In the wiring diagrams, the activation switch has the designation [K]. This represents a component such as a manually operated switch, an emergency stop push button switch, or the contacts of a safety relay or safety PLC.

- In case a manually operated activation switch is used, the switch must be of a type that can be locked out to the open position.
- Inputs IN1 and IN2 must open/close within 200 ms of each other.

## ■ Cable types and lengths

- ABB recommends double-shielded twisted-pair cable.
- Maximum cable lengths:
  - 300 m between activation switch [K] and drive control unit
  - 60 m between multiple drives
  - 60 m between external power supply and first control unit

**Note:** A short-circuit in the wiring between the switch and an STO terminal causes a dangerous fault. Therefore, it is recommended to use a safety relay (including wiring diagnostics) or a wiring method (shield grounding, channel separation) which reduces or eliminates the risk caused by the short-circuit.

**Note:** The voltage at the STO input terminals of the drive must be at least 13 V DC to be interpreted as “1”.

The pulse tolerance of the input channels is 1 ms.

## ■ Grounding of protective shields

- Ground the shield in the cabling between the activation switch and the control unit at the control unit only.
  - Ground the shield in the cabling between two control units at one control unit only.
-

## Operation principle

1. The Safe torque off activates (the activation switch is opened, or safety relay contacts open).
2. The STO inputs of the drive control unit de-energize.
3. The control unit cuts off the control voltage from the output IGBTs.
4. The control program generates an indication as defined by parameter *31.22* (see the firmware manual of the drive).

The parameter selects which indications are given when one or both STO signals are switched off or lost. The indications also depend on whether the drive is running or stopped when this occurs.

**Note:** This parameter does not affect the operation of the STO function itself. The STO function will operate regardless of the setting of this parameter: a running drive will stop upon removal of one or both STO signals, and will not start until both STO signals are restored and all faults reset.

**Note:** The loss of only one STO signal always generates a fault as it is interpreted as a malfunction of STO hardware or wiring.

5. The motor coasts to a stop (if running). The drive cannot restart while the activation switch or safety relay contacts are open. After the contacts close, a reset may be needed (depending on the setting of parameter *31.22*). A new start command is required to start the drive.
-

## Start-up including validation test

To ensure the safe operation of a safety function, validation is required. The final assembler of the machine must validate the function by performing a validation test. The test must be performed

- at initial start-up of the safety function
- after any changes related to the safety function (circuit boards, wiring, components, settings, replacement of inverter module, etc.)
- after any maintenance work related to the safety function
- at the proof test of the safety function
- after a drive firmware update.

### ■ Competence

The validation test of the safety function must be carried out by a competent person with adequate expertise and knowledge of the safety function as well as functional safety, as required by IEC 61508-1 clause 6. The test procedures and report must be documented and signed by this person.

### ■ Validation test reports

Signed validation test reports must be stored in the logbook of the machine. The report shall include documentation of start-up activities and test results, references to failure reports and resolution of failures. Any new validation tests performed due to changes or maintenance shall be logged into the logbook.

### ■ Validation test procedure

After wiring the Safe torque off function, validate its operation as follows.

<b>Action</b>	<input checked="" type="checkbox"/>
 <b>WARNING!</b> Obey the safety instructions. If you ignore them, injury or death, or damage to the equipment can occur.	<input type="checkbox"/>
Make sure that the drive can be run and stopped freely during start-up.	<input type="checkbox"/>
Stop the drive (if running), switch the input power off and isolate the drive from the power line using a disconnecter.	<input type="checkbox"/>
Check the STO circuit connections against the wiring diagram.	<input type="checkbox"/>
Close the disconnecter and switch the power on.	<input type="checkbox"/>

<b>Action</b>	<input checked="" type="checkbox"/>
<p>Test the operation of the STO function when the motor is stopped.</p> <ul style="list-style-type: none"> <li>• Give a stop command for the drive (if running) and wait until the motor shaft is at a standstill.</li> </ul> <p>Make sure that the drive operates as follows:</p> <ul style="list-style-type: none"> <li>• Open the STO circuit. The drive generates an indication if one is defined for the 'stopped' state in parameter 31.22 (see the firmware manual). For warning information, refer to .</li> <li>• Give a start command to verify that the STO function blocks the drive's operation. The drive generates a warning. The motor should not start.</li> <li>• Close the STO circuit.</li> <li>• Reset any active faults. Restart the drive and check that the motor runs normally.</li> </ul>	<input type="checkbox"/>
<p>Test the operation of the STO function when the motor is running.</p> <ul style="list-style-type: none"> <li>• Start the drive and make sure the motor is running.</li> <li>• Open the STO circuit. The motor should stop. The drive generates an indication if one is defined for the 'running' state in parameter 31.22 (see the firmware manual).</li> <li>• Reset any active faults and try to start the drive.</li> <li>• Make sure that the motor stays at a standstill and the drive operates as described above in testing the operation when the motor is stopped.</li> <li>• Close the STO circuit.</li> <li>• Reset any active faults. Restart the drive and check that the motor runs normally.</li> </ul>	<input type="checkbox"/>
<p>Test the operation of the failure detection of the drive. The motor can be stopped or running.</p> <ul style="list-style-type: none"> <li>• Open the 1st channel of the STO circuit. If the motor was running, it should coast to a stop. The drive generates a <i>FAB1 Safe Torque Off 1 loss</i> fault indication (see the firmware manual).</li> <li>• Give a start command to verify that the STO function blocks the drive's operation. The motor should not start.</li> <li>• Close the STO circuit.</li> <li>• Reset any active faults. Restart the drive and check that the motor runs normally.</li> <li>• Open the 2nd channel of the STO circuit. If the motor was running, it should coast to a stop. The drive generates a <i>FA82 Safe Torque Off 2 loss</i> fault indication (see the firmware manual).</li> <li>• Give a start command to verify that the STO function blocks the drive's operation. The motor should not start.</li> <li>• Close the STO circuit.</li> <li>• Reset any active faults. Restart the drive and check that the motor runs normally.</li> </ul>	<input type="checkbox"/>
<p>Document and sign the validation test report which verifies that the safety function is safe and accepted for operation.</p>	<input type="checkbox"/>

## Use

1. Open the activation switch, or activate the safety functionality that is wired to the STO connection.
2. The STO inputs on the drive control unit de-energize, and the control unit cuts off the control voltage from the output IGBTs.
3. The control program generates an indication as defined by parameter *31.22* (see the firmware manual of the drive).
4. The motor coasts to a stop (if running). The drive will not restart while the activation switch or safety relay contacts are open.
5. Deactivate the STO by closing the activation switch, or resetting the safety functionality that is wired to the STO connection.
6. Reset any faults before restarting.



### **WARNING!**

The Safe torque off function does not disconnect the voltage of the main and auxiliary circuits from the drive. Therefore maintenance work on electrical parts of the drive or the motor can only be carried out after isolating the drive from the supply and all other voltage sources.

---



### **WARNING!**

The drive cannot detect or memorize any changes in the STO circuitry when the drive control unit is not powered. If both STO circuits are closed and a level-type start signal is active when the power is restored, it is possible that the drive starts without a fresh start command. Take this into account in the risk assessment of the system.

---

### **Notes:**

- If a running drive is stopped by using the Safe torque off function, the drive will cut off the motor supply voltage and the motor will coast to a stop. If this causes danger or is not otherwise acceptable, stop the drive and machinery using the appropriate stop mode before activating the Safe torque off function.
  - The Safe torque off function overrides all other functions of the drive.
  - The Safe torque off function is ineffective against deliberate sabotage or misuse.
  - The Safe torque off function has been designed to reduce the recognized hazardous conditions. In spite of this, it is not always possible to eliminate all potential hazards. The assembler of the machine must inform the final user about the residual risks.
-

## Maintenance

After the operation of the circuit is validated at start-up, the STO function shall be maintained by periodic proof testing. In high demand mode of operation, the maximum proof test interval is 20 years. In low demand mode of operation, the maximum proof test interval is 5 or 2 years; see section [Safety data \(page 233\)](#). It is assumed that all dangerous failures of the STO circuit are detected by the proof test. To perform the proof test, do the [Validation test procedure \(page 228\)](#).

**Note:** See also the Recommendation of Use CNB/M/11.050 (published by the European co-ordination of Notified Bodies) concerning dual-channel safety-related systems with electromechanical outputs:

- When the safety integrity requirement for the safety function is SIL 3 or PL e (cat. 3 or 4), the proof test for the function must be performed at least every month.
- When the safety integrity requirement for the safety function is SIL 2 (HFT = 1) or PL d (cat. 3), the proof test for the function must be performed at least every 12 months.

The STO function of the drive does not contain any electromechanical components.

In addition to proof testing, it is a good practice to check the operation of the function when other maintenance procedures are carried out on the machinery.

Include the Safe torque off operation test described above in the routine maintenance program of the machinery that the drive runs.

If any wiring or component change is needed after start-up, or the parameters are restored, do the test given in section [Validation test procedure \(page 228\)](#).

Use only spare parts approved by ABB.

Record all maintenance and proof test activities in the machine logbook.

### ■ Competence

The maintenance and proof test activities of the safety function must be carried out by a competent person with adequate expertise and knowledge of the safety function as well as functional safety, as required by IEC 61508-1 clause 6.

---

## Fault tracing

The indications given during the normal operation of the Safe torque off function are selected by drive control program parameter *31.22*.

The diagnostics of the Safe torque off function cross-compare the status of the two STO channels. In case the channels are not in the same state, a fault reaction function is performed and the drive trips on an “STO hardware failure” fault. An attempt to use the STO in a non-redundant manner, for example activating only one channel, will trigger the same reaction.

See the firmware manual of the drive control program for the indications generated by the drive, and for details on directing fault and warning indications to an output on the control unit for external diagnostics.

Any failures of the Safe torque off function must be reported to ABB.

---

## Safety data

The safety data for the Safe torque off function is given below.

**Note:** The safety data is calculated for redundant use, and does not apply if both STO channels are not used.

Frame size	SIL	SC	PL	PFH ( $T_1 = 20$ a) (1/h)	PFH <sub>avg</sub> ( $T_1 = 2$ a)	PFH <sub>avg</sub> ( $T_1 = 5$ a)	PFH <sub>avg</sub> ( $T_1 = 10$ a)	MTTF <sub>D</sub> (a)	DC (%)	SFF (%)	Cat.	HFT	CCF	$T_M$ (a)	PFH <sub>diag</sub> (1/h)	$\lambda_{Diag,s}$ (1/h)	$\lambda_{Diag,d}$ (1/h)
$U_n = 400$ V																	
R1	3	3	e	2.55E-09	2.24E-05	5.59E-05	1.12E-04	2918	≥90	>99	3	1	80	20	1.53E-08	6.06E-08	2.89E-08
R2	3	3	e	2.62E-09	2.31E-05	5.75E-05	1.15E-04	2823	≥90	>99	3	1	80	20	1.53E-08	6.06E-08	2.89E-08
R3	3	3	e	2.59E-09	2.28E-05	5.67E-05	1.14E-04	2870	≥90	>99	3	1	80	20	1.53E-08	6.06E-08	2.89E-08
R4 R4 v2	3	3	e	2.59E-09	2.28E-05	5.68E-05	1.14E-04	2868	≥90	>99	3	1	80	20	1.53E-08	6.06E-08	2.89E-08
R6	3	3	e	3.92E-09	3.44E-05	8.59E-05	1.72E-04	4802	≥90	>99	3	1	80	20	1.40E-12	6.43E-08	1.40E-10
R7	3	3	e	4.22E-09	3.69E-05	9.24E-05	1.85E-04	2805	≥90	>99	3	1	80	20	3.00E-12	1.96E-07	3.00E-10
R8	3	3	e	4.22E-09	3.69E-05	9.24E-05	1.85E-04	2805	≥90	>99	3	1	80	20	3.00E-12	1.96E-07	3.00E-10
R9	3	3	e	4.22E-09	3.69E-05	9.24E-05	1.85E-04	2805	≥90	>99	3	1	80	20	3.00E-12	1.96E-07	3.00E-10
3AXD10001613533 C																	

- The STO is a type A safety component as defined in IEC 61508-2.

- Relevant failure modes:
  - The STO trips spuriously (safe failure)
  - The STO does not activate when requested
  - A fault exclusion on the failure mode “short circuit on printed circuit board” has been made (EN 13849-2, table D.5). The analysis is based on an assumption that one failure occurs at one time. No accumulated failures have been analysed.
- STO response times:
  - STO reaction time (shortest detectable break): 1 ms
  - STO response time: 2 ms (typical), 25 ms (maximum)
  - Fault detection time: Channels in different states for longer than 200 ms
  - Fault reaction time: Fault detection time + 10 ms.
- Indication delays:
  - STO fault indication (parameter 31.22) delay: < 500 ms
  - STO warning indication (parameter 31.22) delay: < 1000 ms.

## ■ Terms and abbreviations

Term or abbreviation	Reference	Description
Cat.	EN ISO 13849-1	Classification of the safety-related parts of a control system in respect of their resistance to faults and their subsequent behavior in the fault condition, and which is achieved by the structural arrangement of the parts, fault detection and/or by their reliability. The categories are: B, 1, 2, 3 and 4.
CCF	EN ISO 13849-1	Common cause failure (%)
DC	EN ISO 13849-1	Diagnostic coverage (%)
HFT	IEC 61508	Hardware fault tolerance
MTTF <sub>D</sub>	EN ISO 13849-1	Mean time to dangerous failure: (Total number of life units) / (Number of dangerous, undetected failures) during a particular measurement interval under stated conditions
PFD <sub>avg</sub>	IEC 61508	Average probability of dangerous failure on demand, that is, mean unavailability of a safety-related system to perform the specified safety function when a demand occurs
PFH	IEC 61508	Average frequency of dangerous failures per hour, that is, average frequency of a dangerous failure of a safety related system to perform the specified safety function over a given period of time

Term or abbreviation	Reference	Description
PFH <sub>diag</sub>	IEC/EN 62061	Average frequency of dangerous failures per hour for the diagnostic function of STO
PL	EN ISO 13849-1	Performance level. Levels a...e correspond to SIL
Proof test	IEC 61508, IEC 62061	Periodic test performed to detect failures in a safety-related system so that, if necessary, a repair can restore the system to an "as new" condition or as close as practical to this condition
SC	IEC 61508	Systematic capability (1...3)
SFF	IEC 61508	Safe failure fraction (%)
SIL	IEC 61508	Safety integrity level (1...3)
STO	IEC/EN 61800-5-2	Safe torque off
$T_1$	IEC 61508-6	Proof test interval. $T_1$ is a parameter used to define the probabilistic failure rate (PFH or PFD) for the safety function or subsystem. Performing a proof test at a maximum interval of $T_1$ is required to keep the SIL capability valid. The same interval must be followed to keep the PL capability (EN ISO 13849) valid. See also section Maintenance.
$T_M$	EN ISO 13849-1	Mission time: the period of time covering the intended use of the safety function/device. After the mission time elapses, the safety device must be replaced. Note that any $T_M$ values given cannot be regarded as a guarantee or warranty.
$\lambda_{\text{Diag}_d}$	IEC 61508-6	Dangerous failure rate (per hour) of the diagnostics function of STO
$\lambda_{\text{Diag}_s}$	IEC 61508-6	Safe failure rate (per hour) of the diagnostics function of STO

■ TÜV certificate

The TÜV certificate is available on the Internet at [www.abb.com/drives/documents](http://www.abb.com/drives/documents).

## ■ Declarations of conformity



# EU Declaration of Conformity

We

Manufacturer: ABB Beijing Drive Systems Co., Ltd.

Address: No.1, Block D, A-10 Jiuxianqiao Beilu, Chaoyang District, Beijing 100015, P.R. China.

Phone: +86 010 58217788

declare under our sole responsibility that the following frequency converters:

**Model ACP510, followed by -01, followed by -02A7, -03A4, -04A1, -05A7, -07A3, -09A5, -12A7, -018A, -026A, -033A, -039A, -046A, -062A, -073A, -088A, -106A, -145A, -169A, -206A, -246A, -293A, -363A, -430A, followed by -4.**

**Model ACP510, followed by -04, followed by -505A, -585A, -650A, -725A, -820A, -880A, followed by -4.**

are in conformity with the relevant requirements of Low Voltage Directive 2014/35/EU, EMC Directive 2014/30/EU, RoHS Directive 2011/65/EU and Ecodesign Directive 2009/125/EC, provided that the equipment is selected, installed and used according to given instructions.

The following harmonized standards have been applied:

### Low Voltage Directive 2014/35/EU

EN 61800-5-1:2007+A1:2017+A11:2021	Adjustable speed electrical power drive systems - Part 5-1: Safety requirements - Electrical, thermal and energy
------------------------------------	---

### EMC Directive 2014/30/EU

EN 61800-3:2004+A1:2012	Adjustable speed electrical power drive systems - Part 3: EMC requirements and specific test methods
-------------------------	---

### RoHS Directive 2011/65/EU

EN IEC 63000:2018	Technical documentation for the assessment of electrical and electronic products with respect to the restriction of hazardous substances
-------------------	--

### Ecodesign Directive 2009/125/EC

EN 61800-9-2:2017	Adjustable speed electrical power drive systems - Part 9-2: Ecodesign for power drive systems, motor starters, power electronics and their driven applications - Energy efficiency indicators for power drive systems and motor starters
-------------------	---

Individual MD Declaration of Conformity for safety functions 3AXD10002160726.



The products referred in this Declaration of conformity fulfil the relevant provisions of other European Union Directives which are notified in Single EU Declaration of conformity 3AXD10001762076.

Authorized to compile the technical file: ABB Oy, Hiomotie 13, 00380 Helsinki, Finland

Beijing, 10 January 2024

Signed for and on behalf of:

Yu Wang  
Local Division Manager  
ABB Beijing Drive Systems Co., Ltd.

A handwritten signature in black ink, appearing to be 'Yu Wang', is written over the printed name and title.

XuMing Wang  
Product Engineering and Quality Manager  
ABB Beijing Drive Systems Co., Ltd.

A handwritten signature in black ink, appearing to be 'XuMing Wang', is written over the printed name and title.

# 14

## Optional I/O extension and adapter modules

---

### Contents of this chapter

This chapter describes how to install and start up the optional CAIO-01, CHDI-01, CMOD-01 and CMOD-02 IO multifunction extension modules and CBAI-01 adapter module. The chapter also contains diagnostics and technical data.

### CAIO-01 bipolar analog I/O adapter module

#### ■ Product overview

The CAIO-01 bipolar analog I/O module expands the inputs and outputs of the drive control unit. It has three bipolar current/voltage inputs and two unipolar current/voltage outputs. The inputs can handle positive and negative signals. The way the drive interprets the negative range of the inputs depends on the parameter settings of the drive. The voltage/current selection of the inputs is done with a parameter.

---

■ **Layout**

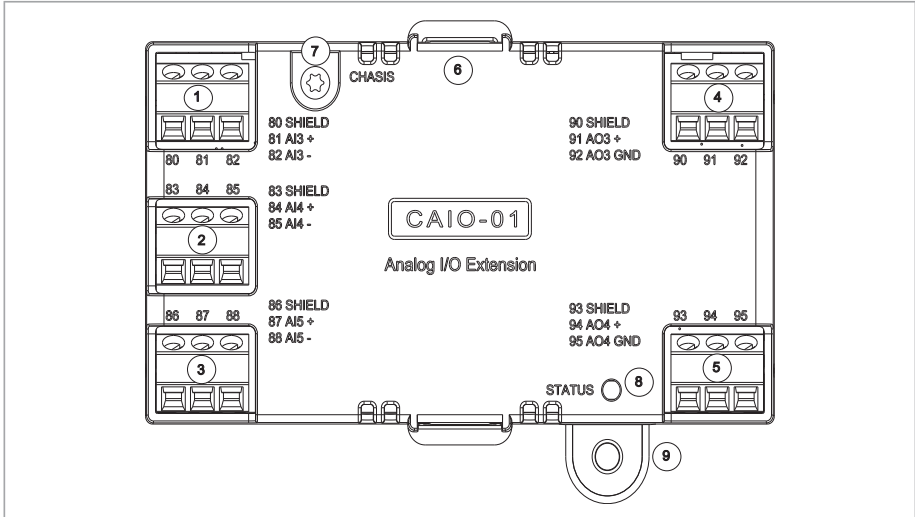

1, 2, 3	Analog inputs		4, 5	Analog outputs	
80	SHIELD	Cable shield connection	90	SHIELD	Cable shield connection
81	AI3+	Analog input 3 positive signal	91	AO3	Analog output 3 signal
82	AI3-	Analog input 3 negative signal	92	AGND	Analog ground potential
83	SHIELD	Cable shield connection	93	SHIELD	Cable shield connection
84	AI4+	Analog input 4 positive signal	94	AO4	Analog output 4 signal
85	AI4-	Analog input 4 negative signal	95	AGND	Analog ground potential
86	SHIELD	Cable shield connection			
87	AI5+	Analog input 5 positive signal			
88	AI5-	Analog input 5 negative signal			
6	Control unit slot interface				
7	Grounding hole				
8	Diagnostic LED				
9	Mounting hole				

## ■ Mechanical Installation

### Necessary tools

- Screwdriver and a set of suitable bits.

### Unpacking and examining the delivery

1. Open the option package. Make sure that the package contains:
  - the option module
  - a mounting screw.
2. Make sure that there are no signs of damage.

### Installing the module

See section [Installing option modules \(page 122\)](#).

## ■ Electrical installation

---



### **WARNING!**

Obey the safety instructions of the drive. If you ignore them, injury or death, or damage to the equipment can occur.

---

Stop the drive and do the steps in section [Electrical safety precautions \(page 20\)](#) before you start the work.

### Necessary tools

- Screwdriver and a set of suitable bits.

### Wiring

Connect the external cables to the applicable module terminals. Ground the outer shield of the cables to the SHIELD terminal.

---

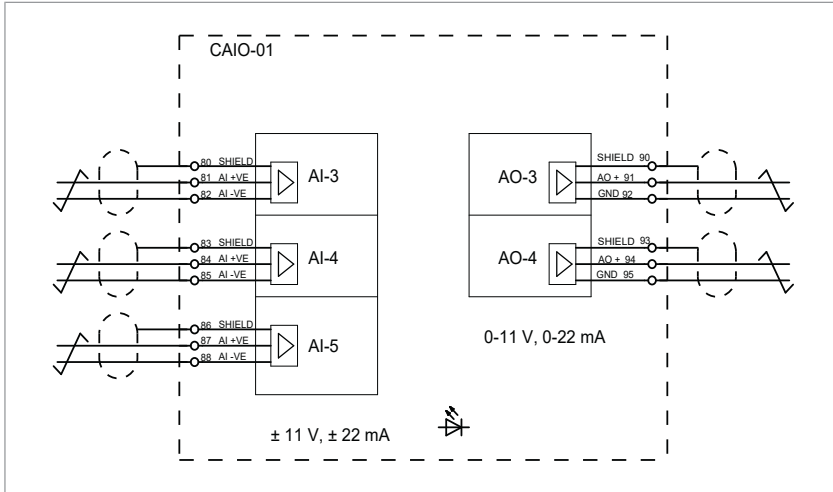

## ■ Start-up

### Setting the parameters

1. Power up the drive.
2. If no warning is shown,
  - make sure that the value of both parameters *15.01 Extension module type* and *15.02 Detected extension module* is CAIO-01.
 If warning *A7AB Extension I/O configuration failure* is shown,
  - make sure that the value of *15.02* is CAIO-01.
  - set the value of parameter *15.01* to CAIO-01.
 You can now see the parameters of the extension module in group *15 I/O extension module*.
3. Set the parameters of analog inputs AI3, AI4, AI5 or analog outputs AO3 or AO4 to applicable values, see the firmware manual.

**Example:** To connect supervision 1 to AI3 of the extension module:

- Select the mode of the supervision function (*32.05 Supervision function 1*).
- Set limits for the supervision function (*32.09 Supervision 1 low* and *32.10 Supervision 1 high*).
- Select the supervision action (*32.06 Supervision 1 action*).
- Connect *32.07 Supervision 1 signal* to *15.52 AI3 scaled value*.

## ■ Diagnostics

### LEDs

The adapter module has one diagnostic LED.

<b>Color</b>	<b>Description</b>
Green	The adapter module is powered up.
Red	There is no communication with the drive control unit or the adapter module has detected an error.

---

## ■ Technical data

Installation	Into slot 2 of drive control unit
Degree of protection	IP20
Ambient conditions	See the drive technical data.
Package	Cardboard
<b>Analog inputs (80..82, 83..85, 86..88)</b>	
Maximum wire size	1.5 mm <sup>2</sup>
Input voltage ( AI+ and AI-)	-11 V ... +11 V
Input current ( AI+ and AI-)	-22 mA ... +22 mA
Input resistance	>200 kohm (voltage mode), 100 ohm (current mode)
Optional cable shield connections	
<b>Analog outputs (90..92, 93..95)</b>	
Maximum wire size	1.5 mm <sup>2</sup>
Output voltage (AO+ and AO-)	0 V ... +11 V
Output current (AO+ and AO-)	0 mA ... +22 mA
Output resistance	< 20 ohm
Recommended load	>10 kohm
Inaccuracy	± 1% Typical, ± 1.5% Max of full-scale value
Optional cable shield connections	

**Isolation areas**

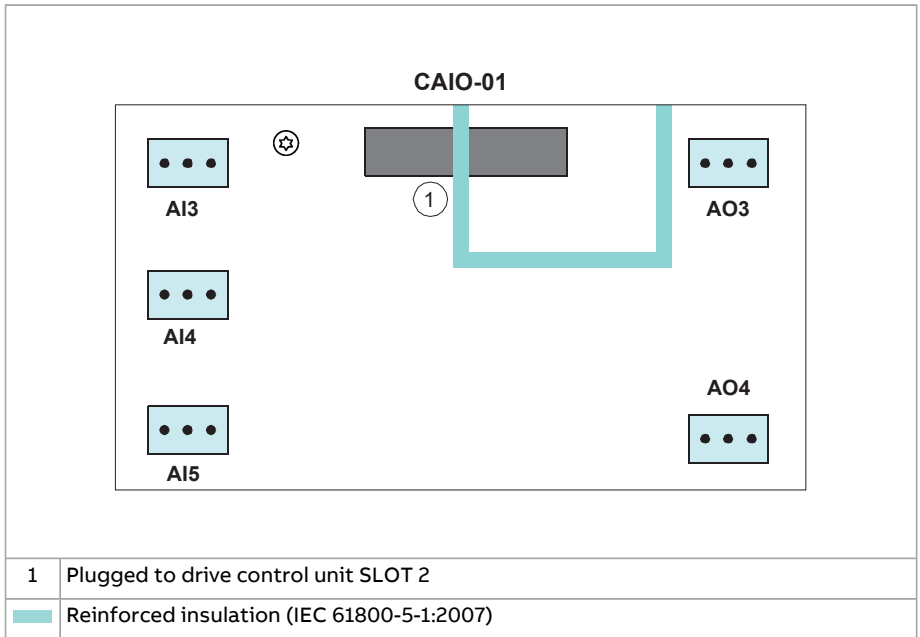

■ **Dimension drawings**

The dimensions are in millimeters.

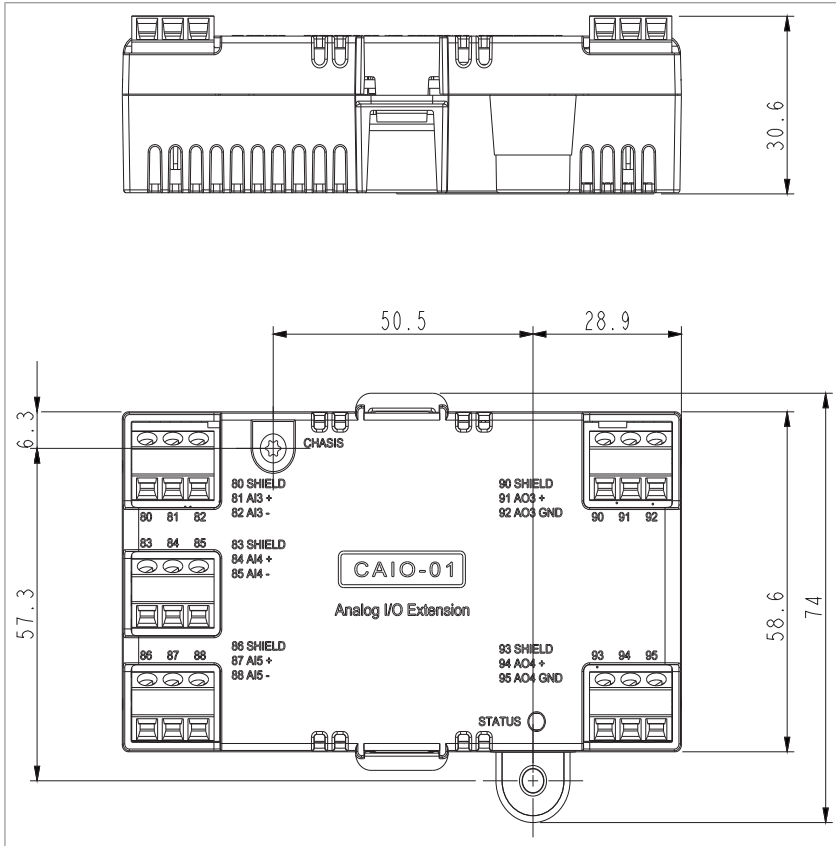

**CBAI-01 bipolar analog IO adapter module**

■ **Product overview**

The CBAI-01 includes two bipolar analog inputs, two unipolar analog outputs, and a switch which can be used to select scaling of the analog output level. The module converts the bipolar analog inputs (-10...+10 V) to respective unipolar analog inputs 0...+10 V which can be connected to the drive control unit. It offers no additional inputs.

■ **Layout**

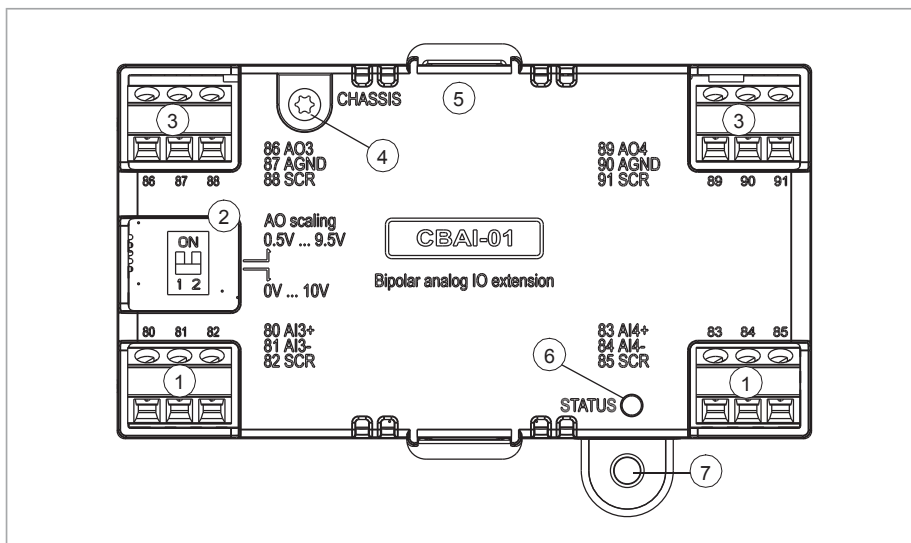

Analog inputs (1)			Analog outputs (3)		
80	AI3+	Analog input 3 positive signal	86	AO3	Analog output 3 signal
81	AI3-	Analog input 3 negative signal	87	AGND	Analog ground potential
82	SCR	Cable shield connection	88	SCR	Cable shield connection
83	AI4+	Analog input 4 positive signal	89	AO4	Analog output 4 signal
84	AI4-	Analog input 4 negative signal	90	AGND	Analog ground potential
85	SCR	Cable shield connection	91	SCR	Cable shield connection
2	Analog output scale switch (2)		4	Grounding hole	
5	Control unit SLOT 2 interface		6	Diagnostic LED	
7	Grounding hole		-		

■ **Mechanical Installation**

**Necessary tools**

- Screwdriver and a set of suitable bits.

### Unpacking and examining the delivery

1. Open the option package. Make sure that the package contains:
  - the option module
  - a mounting screw.
2. Make sure that there are no signs of damage.

### Installing the module

See section [Installing option modules \(page 122\)](#).

#### ■ Electrical installation



#### WARNING!

Obey the instructions in chapter [Safety instructions \(page 17\)](#). If you ignore them, injury or death, or damage to the equipment can occur. If you are not a qualified electrician, do not do electrical work.

**Make sure that the drive is disconnected from the input power during installation. If the drive is already connected to the input power, wait for 5 minutes after disconnecting the input power.**

#### Necessary tools

- Screwdriver and a set of suitable bits.

#### Wiring

Connect the external control cables to the applicable module terminals. Ground the outer shield of the cables 360 degrees under a grounding clamp on the grounding shelf of the control cables and the pair cable shield to the SCR terminal of CBAI-01.

Connection diagram:

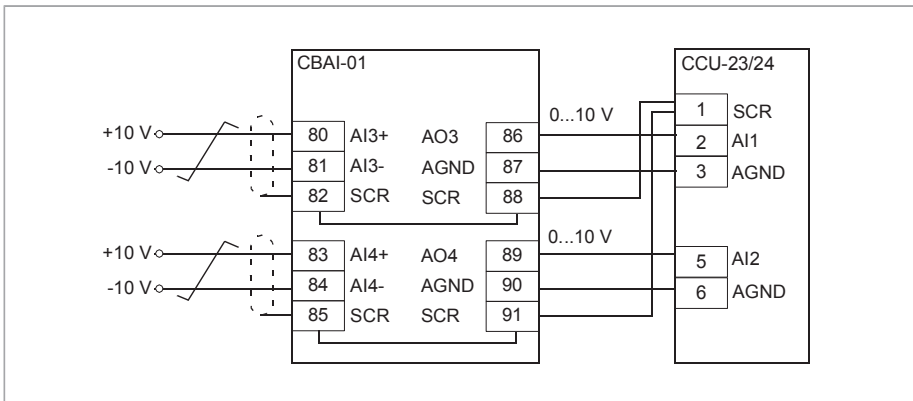

## ■ Start-up

### Setting the parameters

1. Power up the drive.
2. Verify that the diagnostic LED is on.

#### Parameter setting example for AI1

This example shows how to set the control unit parameters for a bipolar speed reference ranging from -50 Hz to 50 Hz, with detection of a wire break between the adapter module and the control unit of the drive.

Parameter	Setting	Default
12.17 AI1 min	0.5 V	4.000 mA or 0.000 V
12.18 AI1 max	9.5 V	20.000 mA or 10.000 V
12.19 AI1 scaled at AI1 min	-50	0.000
12.20 AI1 scaled at AI1 max	50	50
32.05 Supervision 1 function	Low	Disabled
32.06 Supervision 1 action	Fault	No action
32.07 Supervision 1 signal	AI1	Frequency
32.09 Supervision 1 low	0.4	0.00

## ■ Diagnostics

### LEDs

The adapter module has one diagnostic LED.

Color	Description
Green	The adapter module is powered up.

## ■ Technical data

Installation	Into SLOT 2 on the drive control unit
Degree of protection	IP20
Ambient conditions	See the drive technical data.

## 250 Optional I/O extension and adapter modules

Package	Cardboard
<b>Analog inputs (80...82, 83...85)</b>	
Maximum wire size	1.5 mm <sup>2</sup>
Input voltage (AI+ and AI-)	-10 V ... +10 V
Input resistance	> 200 kohm
Optional cable shield connection	
<b>Analog outputs (86...88, 89...91)</b>	
Maximum wire size	1.5 mm <sup>2</sup>
Output voltage (AO+ and AGND)	0 V ... +10 V
Output resistance	< 20 ohm
Recommended load	> 10 kohm
Inaccuracy	typical ±1%, max. ±1.5% of full scale
Optional cable shield connection	
<b>Analog output scale switch</b>	
ON state	0.5 V ... 9.5 V range in use
OFF state	0 V ...10 V range in use

**Isolation areas**

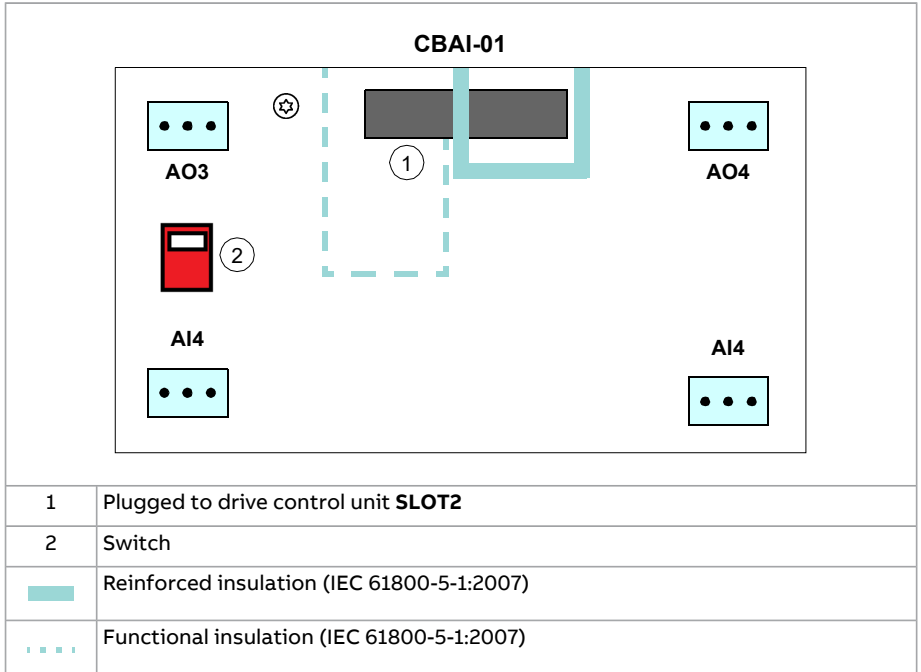

■ **Dimension drawing**

The dimensions are in millimeters and [inches].



■ Layout and connection examples

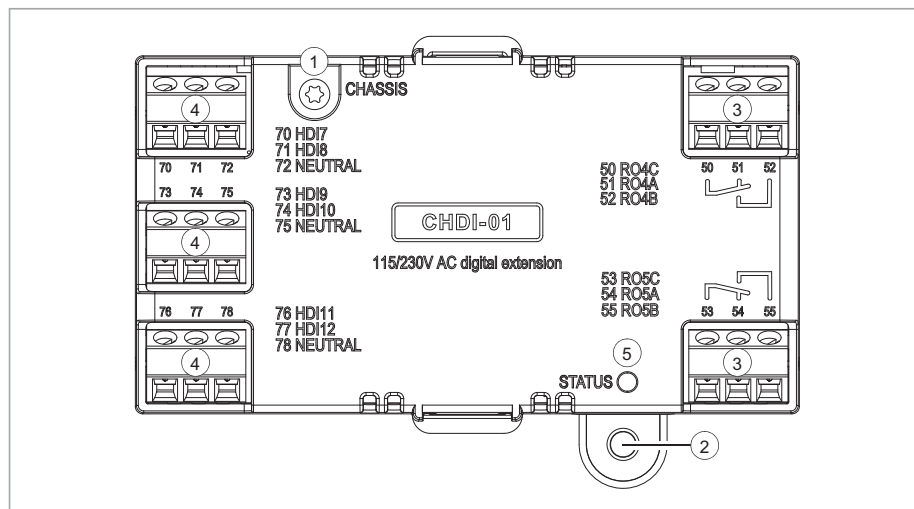

**4** 3-pin terminal blocks for 115/230 V inputs

**3** Relay outputs

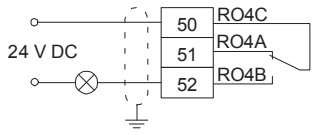
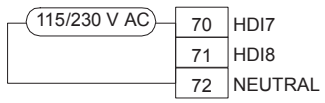

70	HDI7	115/230 V input 1	50	RO4C	Common, C
71	HDI8	115/230 V input 2	51	RO4A	Normally closed, NC
72	NEUTRAL <sup>1)</sup>	Neutral point	52	RO4B	Normally open, NO
73	HDI9	115/230 V input 3	53	RO5C	Common, C
74	HDI10	115/230 V input 4	54	RO5A	Normally closed, NC
75	NEUTRAL <sup>1)</sup>	Neutral point	55	RO5B	Normally open, NO
76	HDI11	115/230 V input 5	<b>1</b> <b>Grounding screw</b>		
77	HDI12	115/230 V input 5	<b>2</b> <b>Hole for mounting screw</b>		
78	NEUTRAL <sup>1)</sup>	Neutral point	<b>5</b> <b>Diagnostic LED.</b> Green = The extension module is powered up.		
<sup>1)</sup> Neutral points 72, 75 and 78 are connected.					

## ■ Mechanical Installation

### Necessary tools

- Screwdriver and a set of suitable bits.

### Unpacking and examining the delivery

1. Open the option package. Make sure that the package contains:
  - the option module
  - a mounting screw.
2. Make sure that there are no signs of damage.

### Installing the module

See section [Installing option modules \(page 122\)](#).

## ■ Electrical installation

---



### WARNING!

Obey the safety instructions of the drive. If you ignore them, injury or death, or damage to the equipment can occur.

---

Stop the drive and do the steps in section [Electrical safety precautions \(page 20\)](#) before you start the work.

### Necessary tools

- Screwdriver and a set of suitable bits.

### Wiring

Connect the external control cables to the applicable module terminals. Ground the outer shield of the cables 360 degrees under a grounding clamp on the grounding shelf of the control cables.

## ■ Start-up

### Setting the parameters

1. Power up the drive.
2. If no warning is shown,
  - make sure that the value of both parameters *15.01 Extension module type* and *15.02 Detected extension module* is CHDI-01.

If warning the *A7AB Extension I/O configuration failure* is shown,

- make sure that the value of parameter *15.02* is CHDI-01.
- set parameter *15.01* value to CHDI-01.

You can now see the parameters of the extension module in parameter group *15 I/O extension module*.

---

3. Set the parameters of the extension module to applicable values.

Parameter setting example for relay output

This example shows how make the relay output RO4 of the extension module indicate the reverse direction of rotation of the motor with a one-second delay.

Parameter	Setting
15.07 RO4 source	Reverse
15.08 RO4 ON delay	1 s
15.09 RO4 OFF delay	1 s

■ **Fault and warning messages**

Warning A7AB *Extension I/O configuration failure.*

■ **Technical data**

Installation	Into an option slot on the drive control unit
Degree of protection	IP20
Ambient conditions	See the drive technical data.
Package	Cardboard
<b>Relay outputs (50...52, 53...55)</b>	
Maximum wire size	1.5 mm <sup>2</sup>
Minimum contact rating	12 V / 10 mA
Maximum contact rating	250 V AC / 30 V DC / 2 A
Maximum breaking capacity	1500 VA
<b>115/230 V inputs (70...78)</b>	
Maximum wire size	1.5 mm <sup>2</sup>
Input voltage	115 to 230 V AC ±10%
Maximum current leakage in digital off state	2 mA

**Isolation areas**

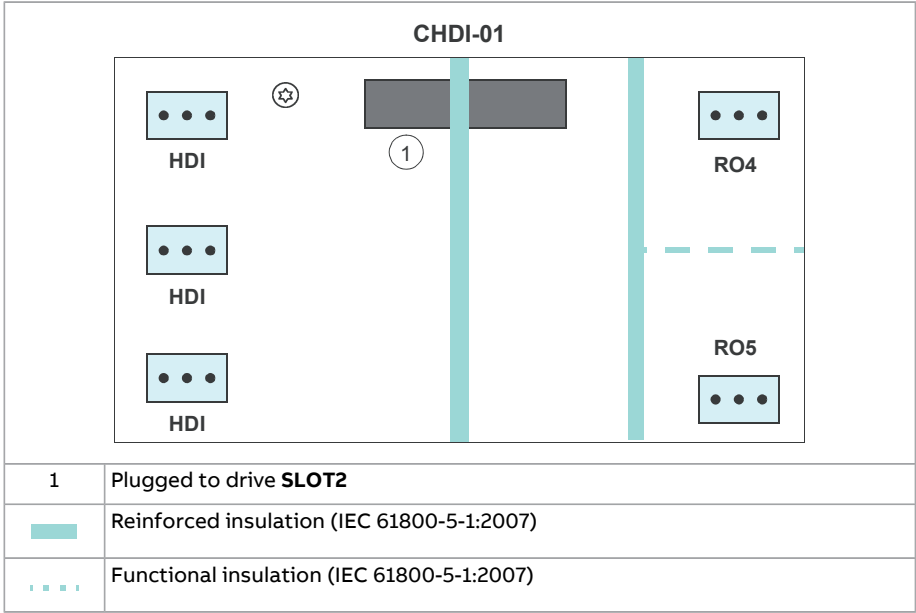

■ **Dimension drawing**

The dimensions are in millimeters and [inches].

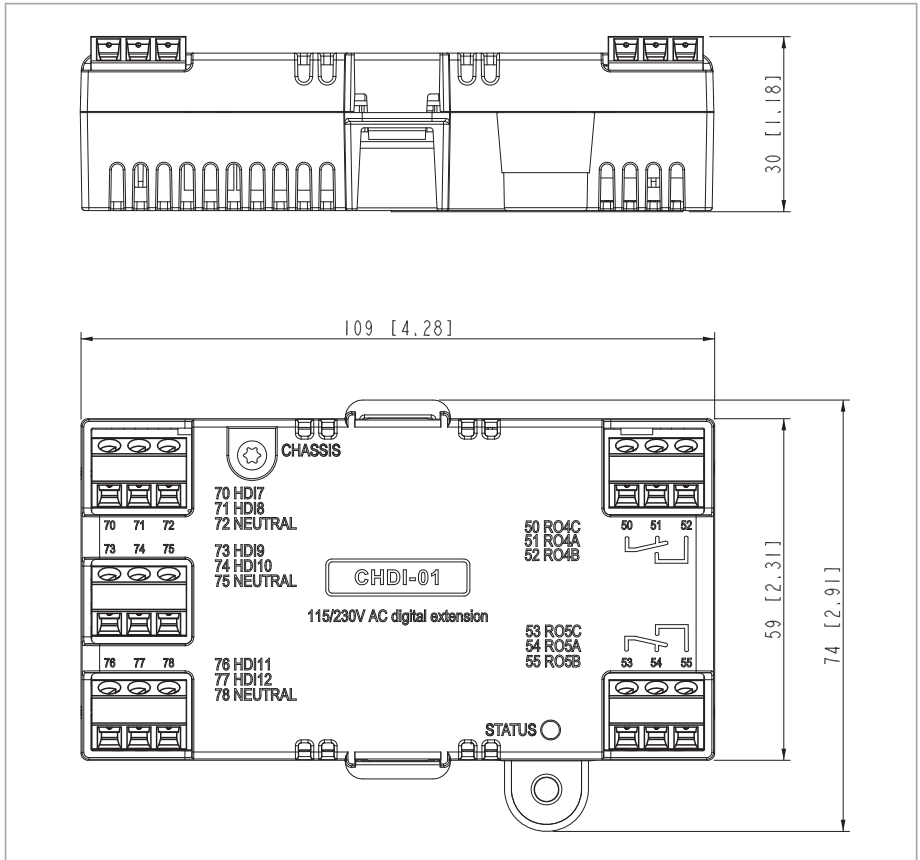

**CMOD-01 multifunction extension module (external 24 V AC/DC and digital I/O)**

■ **Product overview**

The CMOD-01 multifunction extension module (external 24 V AC/DC and digital I/O) expands the outputs of the drive control unit. It has two relay outputs and one transistor output, which can function as a digital or frequency output.

In addition, the extension module has an external power supply interface, which can be used to power up the drive control unit in case the drive power supply is

not on. If you do not need the back-up power supply, you do not have to connect it because the module is powered from the drive control unit by default.

**Note:** With CCU-24 control unit, a CMOD-01 module is not necessary for external 24 V AC/DC supply connection. The external supply is connected directly to terminals 40 and 41 on the control unit.

■ **Layout and example connections**

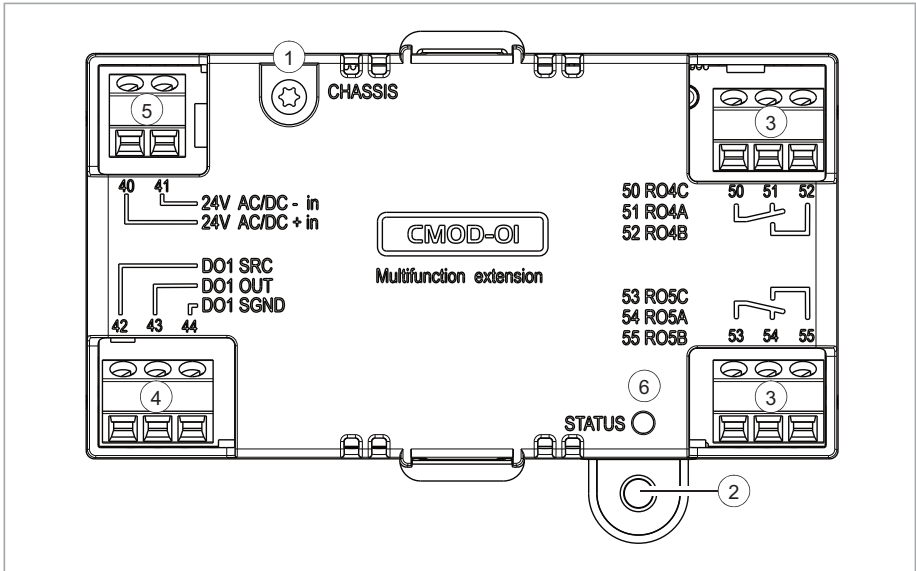

<b>1</b> Grounding screw	<b>6</b> Diagnostic LED
<b>2</b> Hole for mounting screw	
<b>5</b> 2-pin terminal block for external power supply	<b>3</b> 3-pin terminal blocks for relay outputs

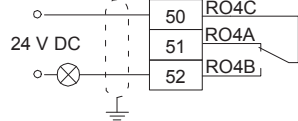
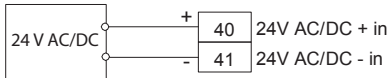

40	24 V AC/DC + in	External 24 V (AC/DC) input	50	RO4C	Common, C
41	24 V AC/DC - in	External 24 V (AC/DC) input	51	RO4A	Normally closed, NC

4	<b>3-pin terminal block for for transistor output</b>		52	RO4B	Normally open, NO
<p>1)</p> <p>2)</p>					
42	DO1 SRC	Source input	53	RO5C	Common, C
43	DO1 OUT	Digital or frequency output	54	RO5A	Normally closed, NC
44	DO1 SGND	Ground (earth) potential	55	RO5B	Normally open, NO

1) Digital output connection example

- 2) An externally supplied frequency indicator which provides, for example:
- a 40 mA / 12 V DC power supply for the sensor circuit (CMOD frequency output)
  - suitable voltage pulse input (10 Hz ... 16 kHz).

## ■ Mechanical Installation

### Necessary tools

- Screwdriver and a set of suitable bits.

### Unpacking and examining the delivery

1. Open the option package. Make sure that the package contains:
  - the option module
  - a mounting screw.
2. Make sure that there are no signs of damage.

### Installing the module

See section [Installing option modules \(page 122\)](#).

## ■ Electrical installation

---



### **WARNING!**

Obey the safety instructions of the drive. If you ignore them, injury or death, or damage to the equipment can occur.

---

Stop the drive and do the steps in section [Electrical safety precautions \(page 20\)](#) before you start the work.

### **Necessary tools**

- Screwdriver and a set of suitable bits

### **Wiring**

Connect the external control cables to the applicable module terminals. Ground the outer shield of the cables 360 degrees under a grounding clamp on the grounding shelf of the control cables.

---



### **WARNING!**

Do not connect the +24 V AC cable to the control unit ground when the control unit is powered using an external 24 V AC supply.

---

## ■ Start-up

### **Setting the parameters**

1. Power up the drive.
2. If no warning is shown,
  - make sure that the value of both parameters *15.01 Extension module type* and *15.02 Detected extension module* is CMOD-01.If the warning *A7AB Extension I/O configuration failure* is shown,
  - make sure that the value of parameter *15.02* is CMOD-01.
  - set the parameter *15.01* value to CMOD-01.You can now see the parameters of the extension module in parameter group *15 I/O extension module*.
3. Set the parameters of the extension module to applicable values.

Examples are given below.

### Parameter setting example for relay output

This example shows how make relay output RO4 of the extension module indicate the reverse direction of rotation of the motor with a one-second delay.

---

Parameter	Setting
15.07 RO4 source	Reverse
15.08 RO4 ON delay	1 s
15.09 RO4 OFF delay	1 s

#### Parameter setting example for digital output

This example shows how to make digital output DO1 of the extension module indicate the reverse direction of rotation of the motor with a one-second delay.

Parameter	Setting
15.22 DO1 configuration	Digital output
15.23 DO1 source	Reverse
15.24 DO1 ON delay	1 s
15.25 DO1 OFF delay	1 s

#### Parameter setting example for frequency output

This example shows how to make digital output DO1 of the extension module indicate the motor speed 0...1500 rpm with a frequency range of 0...10000 Hz.

Parameter	Setting
15.22 DO1 configuration	Frequency output
15.33 Freq out 1 source	01.01 Motor speed used
15.34 Freq out 1 src min	0
15.35 Freq out 1 src max	1500.00
15.36 Freq out 1 at src min	1000 Hz
15.37 Freq out 1 at src max	10000 Hz

## **Diagnostics**

### Faults and warning messages

Warning A7AB Extension I/O configuration failure.

### LEDs

The extension module has one diagnostic LED.

---

Color	Description
Green	The extension module is powered up.

### ■ Technical data

Installation	Into an option slot on the drive control unit
Degree of protection	IP20
Ambient conditions	See the drive technical data.
Package	Cardboard
<b>Relay outputs (50...52, 53...55)</b>	
Maximum wire size	1.5 mm <sup>2</sup>
Minimum contact rating	12 V / 10 mA
Maximum contact rating	250 V AC / 30 V DC / 2 A
Maximum breaking capacity	1500 VA
<b>Transistor output (42...44)</b>	
Maximum wire size	1.5 mm <sup>2</sup>
Type	Transistor output PNP
Maximum load	4 kohm
Maximum switching voltage	30 V DC
Maximum switching current	100 mA / 30 V DC, short-circuit protected
Frequency	10 Hz ... 16 kHz
Resolution	1 Hz
Inaccuracy	0.2%
<b>External power supply (40...41)</b>	
Maximum wire size	1.5 mm <sup>2</sup>
Input voltage	24 V AC / V DC ±10% (GND, user potential)
Maximum power consumption	25 W, 1.04 A at 24 V DC

**Isolation areas**

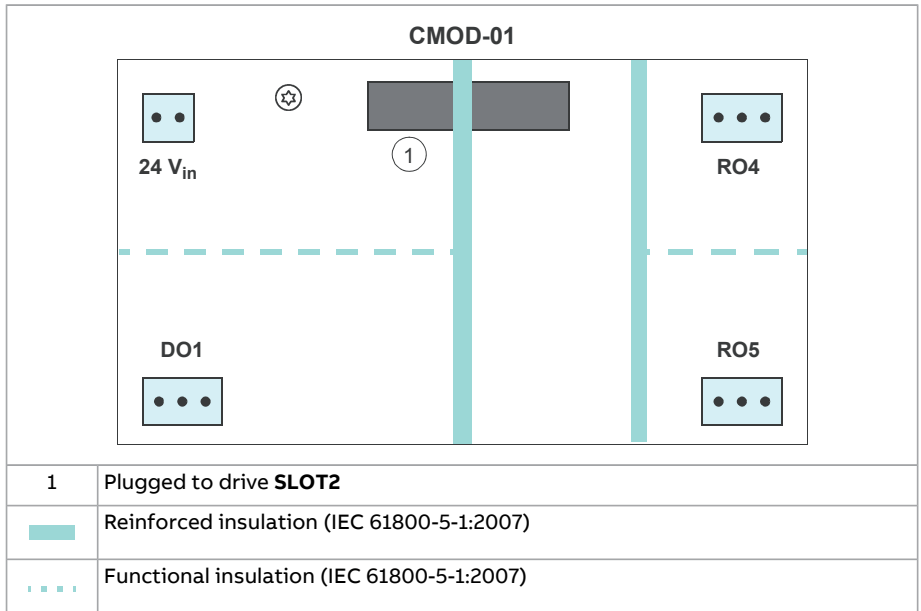

■ **Dimension drawing**

The dimensions are in millimeters and [inches].

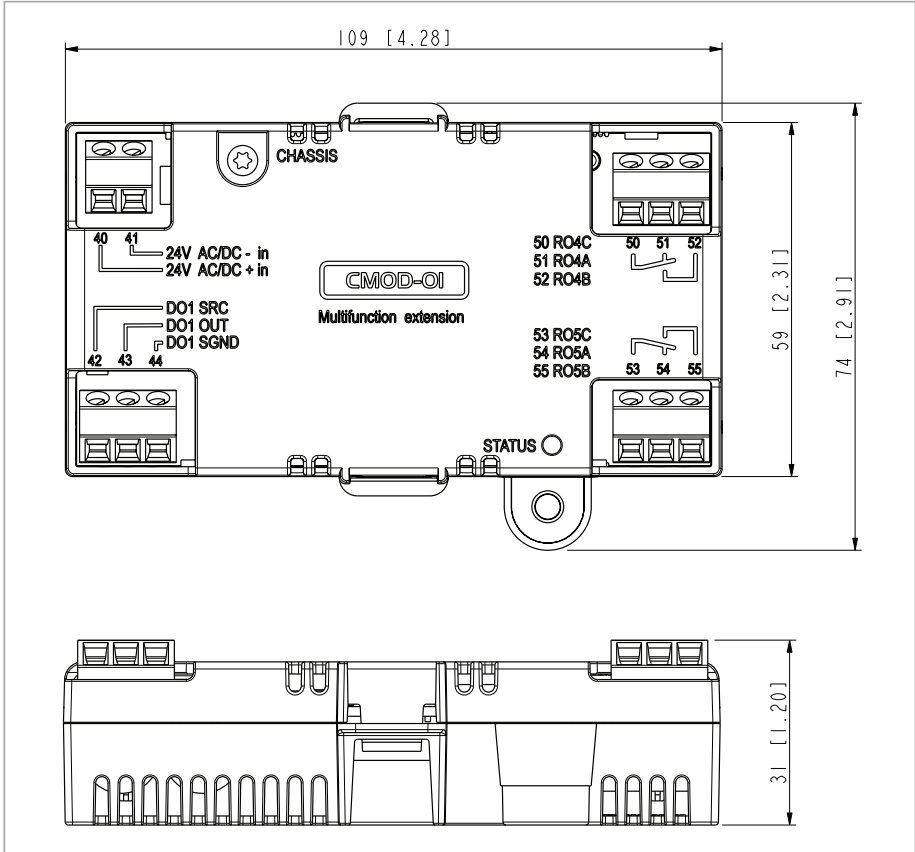

**CMOD-02 multifunction extension module (external 24 V AC/DC and isolated PTC interface)**

■ **Product overview**

The CMOD-02 multifunction extension module (external 24 V AC/DC and isolated PTC interface) has a motor thermistor connection for supervising the motor temperature and one relay output, which indicates the thermistor status. In case the thermistor overheats, the drive trips on motor overtemperature. If Safe torque off tripping is required, the user must wire the overtemperature indication relay to the certified Safe torque off input of the drive.

In addition, the extension module has an external power supply interface, which can be used to power up the drive control unit in case the drive power supply is not on. If you do not need the back-up power supply, you do not have to connect it because the module is powered from the drive control unit by default.

There is reinforced insulation between the motor thermistor connection, the relay output and the drive control unit interface. Thus, you can connect a motor thermistor to the drive through the extension module.

**Note:** With CCU-24 control unit, a CMOD-02 module is not necessary for external 24 V AC/DC supply connection. The external supply is connected directly to terminals 40 and 41 on the control unit.

### ■ Layout and example connections

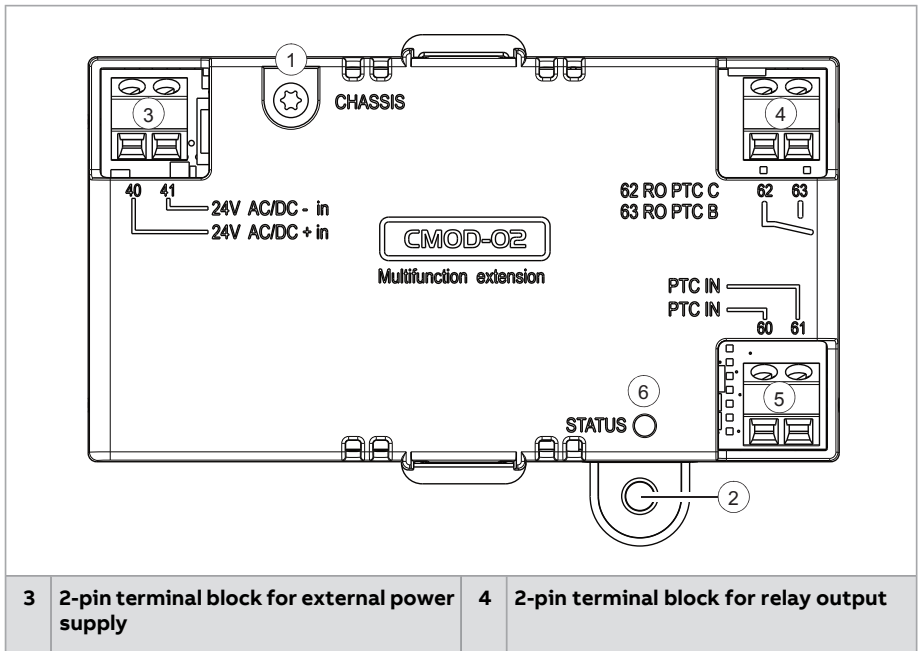

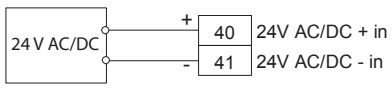
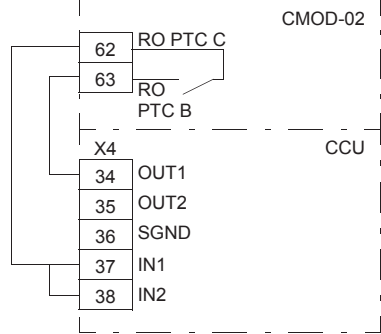
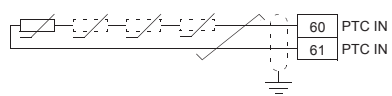
					
40	24 V AC/DC + in	External 24 V (AC/DC) input	62	RO PTC C	Common, C
41	24 V AC/DC - in	External 24 V (AC/DC) input	63	RO PTC B	Normally open, NO
<b>5</b>	<b>Motor thermistor connection</b>		<b>1</b>	<b>Grounding screw</b>	
 <p>One to six PTC thermistors connected in series.</p>					
60	PTC IN	PTC connection			
61	PTC IN	Ground (earth) potential	<b>6</b>	<b>Diagnostic LED</b>	

**■ Mechanical Installation**

**Necessary tools**

- Screwdriver and a set of suitable bits.

**Unpacking and examining the delivery**

1. Open the option package. Make sure that the package contains:
  - the option module
  - a mounting screw.
2. Make sure that there are no signs of damage.

## Installing the module

See section [Installing option modules \(page 122\)](#).

### ■ Electrical installation

---



#### **WARNING!**

Obey the safety instructions of the drive. If you ignore them, injury or death, or damage to the equipment can occur.

---

Stop the drive and do the steps in section [Electrical safety precautions \(page 20\)](#) before you start the work.

### Necessary tools

- Screwdriver and a set of suitable bits

### Wiring

Connect the external control cables to the applicable module terminals. Ground the outer shield of the cables 360 degrees under a grounding clamp on the grounding shelf of the control cables.

---



#### **WARNING!**

Do not connect the +24 V AC cable to the control unit ground when the control unit is powered using an external 24 V AC supply.

---

### ■ Start-up

#### Setting the parameters

1. Power up the drive.
2. If no warning is shown,
  - make sure that the values of both parameters *15.01 Extension module type* and *15.02 Detected extension module* are CMOD-02.
 If the warning *A7AB Extension I/O configuration failure* is shown,
  - make sure that the value of parameter *15.02* is CMOD-02.
  - set the parameter *15.01* value to CMOD-02.
 You can now see the parameters of the extension module in parameter group *15 I/O extension module*.

### ■ Diagnostics

#### Faults and warning messages

Warning A7AB Extension I/O configuration failure.

---

## LEDs

The extension module has one diagnostic LED.

Color	Description
Green	The extension module is powered up.

## ■ Technical data

Installation	Into option slot 2 on the drive control unit
Degree of protection	IP20
Ambient conditions	See the drive technical data.
Package	Cardboard
<b>Motor thermistor connection (60...61)</b>	
Maximum wire size	1.5 mm <sup>2</sup>
Supported standards	DIN 44081 and DIN 44082
Triggering threshold	3.6 kohm ±10%
Recovery threshold	1.6 kohm ±10%
PTC terminal voltage	≤ 5.0 V
PTC terminal current	< 1 mA
Short-circuit detection	< 50 ohm ±10%
<p>The PTC input is reinforced/double insulated. If the motor part of the PTC sensor and wiring are reinforced/double insulated, voltages on the PTC wiring are within SELV limits.</p> <p>If the motor PTC circuit is not reinforced/double insulated (ie, it is basic insulated), it is mandatory to use reinforced/double insulated wiring between the motor PTC and CMOD-02 PTC terminal.</p>	
<b>Relay output (62...63)</b>	
Maximum wire size	1.5 mm <sup>2</sup>
Maximum contact rating	250 V AC / 30 V DC / 5 A
Maximum breaking capacity	1000 VA
<b>External power supply (40...41)</b>	
Maximum wire size	1.5 mm <sup>2</sup>
Input voltage	24 V AC / V DC ±10% (GND, user potential)
Maximum power consumption	25 W, 1.04 A at 24 V DC

**Isolation areas**

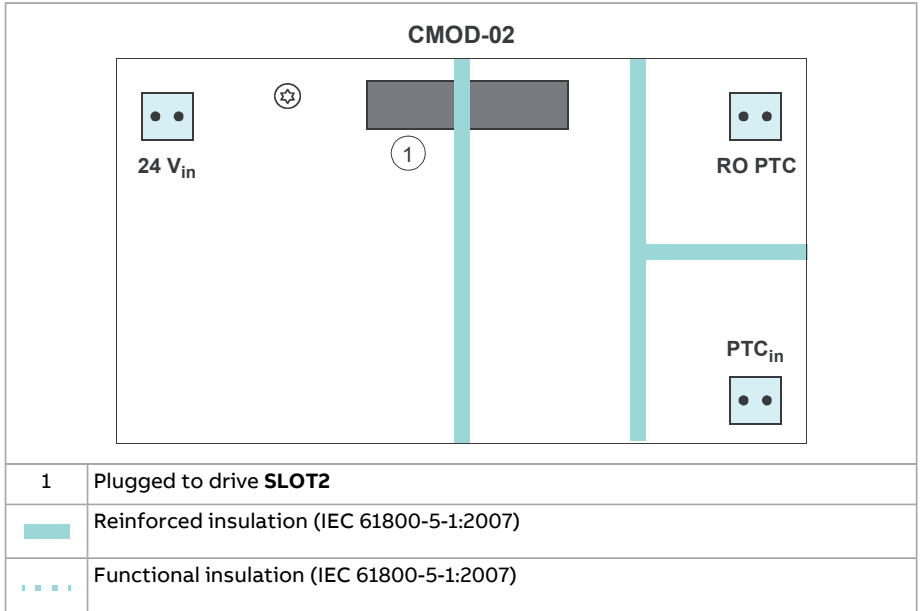

■ **Dimension drawing**

The dimensions are in millimeters and [inches].

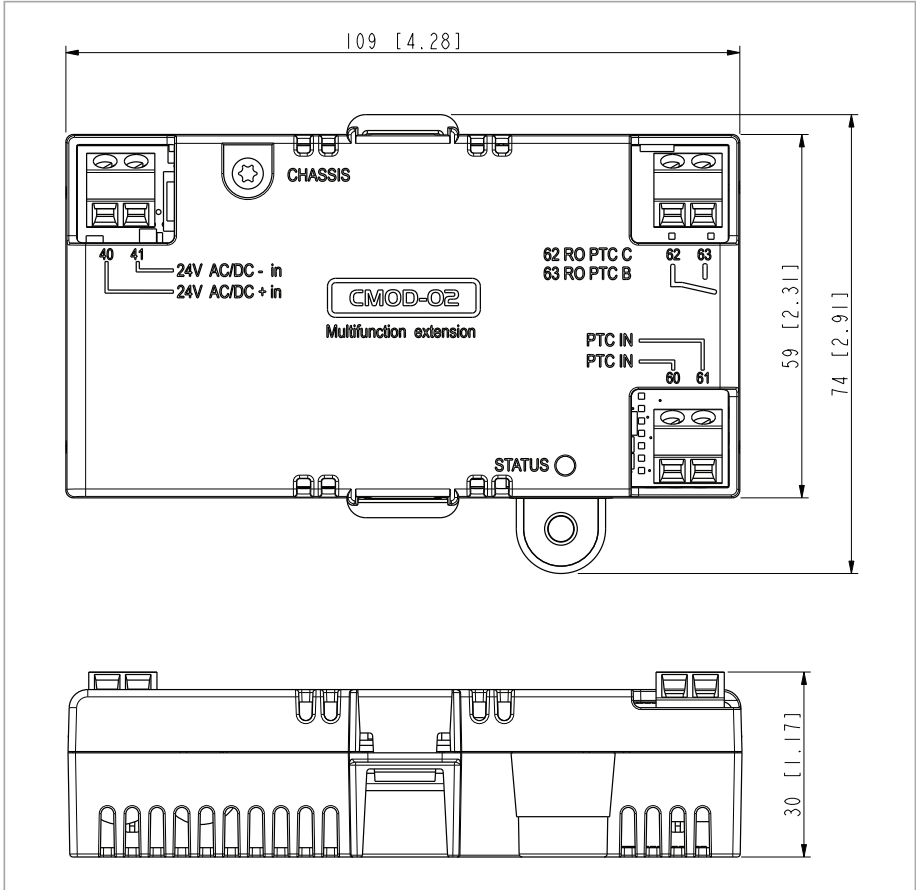

## 15

# Common mode, du/dt and sine filters

---

## Content of this chapter

This chapter describes how to select external filters for the drive.

## Common mode filters

### ■ When is a common mode filter needed?

See section [Examining the compatibility of the motor and drive \(page 66\)](#).

Common mode filter kits are available from ABB, see the table below. A kit includes three wound cores. For installation instructions of the cores, see the instruction included in the core package.

### ■ Common mode filter types

#### IEC ratings at $U_n = 400\text{ V}$

For common mode filters for smaller types, contact your local representative.

IEC type ACP510-01-	Common mode filters ABB drives	Frame size
062A-4	64315811	R4
073A-4	64315811	R4
088A-4	64315811	R5

---

IEC type ACP510-01-	Common mode filters ABB drives	Frame size
089A-4	64315811	R4 v2
106A-4	64315811	R5
145A-4	3AXD50000017269	R6
169A-4	3AXD50000017270	R7
206A-4	3AXD50000017270	R7
246A-4	3AXD50000018001	R8
293A-4	3AXD50000018001	R8
363A-4	3AXD50000017940	R9
430A-4	3AXD50000017940	R9

## du/dt filters

### ■ When is a du/dt filter needed?

See section [Examining the compatibility of the motor and drive \(page 66\)](#).

See the table of du/dt filters below.

### ■ du/dt filter types

IEC ratings at  $U_n = 400 \text{ V}$

Type ACP510-01-	du/dt filters ABB drives	Frame size
02A7-4	LOCH0016-60 or NOCH0016-6x	R1
03A4-4	LOCH0016-60 or NOCH0016-6x	R1
04A1-4	LOCH0016-60 or NOCH0016-6x	R1
05A7-4	LOCH0016-60 or NOCH0016-6x	R1
07A3-4	LOCH0016-60 or NOCH0016-6x	R1
09A5-4	LOCH0016-60 or NOCH0016-6x	R1
12A7-4	LOCH0016-60 or NOCH0016-6x	R1
018A-4	LOCH0030-60 or NOCH0016-6x	R2
026A-4	LOCH0030-60 or NOCH0016-6x	R2
033A-4	LOCH0070-60 or NOCH0070-6x	R3
039A-4	LOCH0070-60 or NOCH0070-6x	R3

Type ACP510-01-	du/dt filters ABB drives	Frame size
046A-4	LOCH0070-60 or NOCH0070-6x	R3
062A-4	LOCH0070-60 or NOCH0070-6x	R4
073A-4	NOCH0070-6x or NOCH0120-6x	R4
088A-4	NOCH0120-6x	R5
089A-4	NOCH0120-6x	R4 v2
106A-4	NOCH0120-6x	R5
145A-4	FOCH0260-70	R6
169A-4	FOCH0260-70	R7
206A-4	FOCH0260-70	R7
246A-4	FOCH0260-70	R8
293A-4	FOCH0260-70	R8
363A-4	FOCH0320-50	R9
430A-4	FOCH0320-50	R9

■ **Description, installation and technical data of the FOCH filters**

See *FOCH du/dt filters hardware manual* (3AFE68577519 [English]).

■ **Description, installation and technical data of the NOCH filters**

See *AOCH and NOCH du/dt filters hardware manual* (3AFE58933368 [English]).

## Sine filters

■ **IEC ratings at  $U_n = 400$  and  $480$  V**

Type ACP510-01-	Sine filter type		Frame size
	Epcos sine filter (IP00)	Housing (IP20)	
02A7-4	B84143V0004R229	B84143Q0002R229	R1
03A4-4	B84143V0004R229	B84143Q0002R229	R1
04A1-4	B84143V0004R229	B84143Q0002R229	R1
05A7-4	B84143V0006R229	B84143Q0002R229	R1
07A3-4	B84143V0011R229	B84143Q0004R229	R1
09A5-4	B84143V0011R229	B84143Q0004R229	R1
12A7-4	B84143V0016R229	B84143Q0006R229	R1

## 274 Common mode, du/dt and sine filters

018A-4	B84143V0016R229	B84143Q0006R229	R2
026A-4	B84143V0025R229	B84143Q0008R229	R2
033A-4	B84143V0033R229	B84143Q0008R229	R3
039A-4	B84143V0050R229	B84143Q0010R229	R3
046A-4	B84143V0050R229	B84143Q0010R229	R3
062A-4	B84143V0066R229	B84143Q0010R229	R4
073A-4	B84143V0066R229	B84143Q0010R229	R4
088A-4	B84143V0095R229	B84143Q0012R229	R5
089A-4	B84143V0095R229	B84143Q0012R229	R4,v2
106A-4	B84143V0095R229	B84143Q0012R229	R5
145A-4	B84143V0162S229	B84143Q0014R229	R6
169A-4	B84143V0162S229	B84143Q0014R229	R7
206A-4	B84143V0230S229	B84143Q0016R229	R7
246A-4	B84143V0230S229	B84143Q0016R229	R8
293A-4	B84143V0390S229	B84143Q0018R229	R8
363A-4	B84143V0390S229	B84143Q0018R229	R9
430A-4	B84143V0390S229	B84143Q0018R229	R9

### ■ Description, installation and technical data

See *Sine filters hardware manual* (3AXD50000016814 [English]).

---

---

## Further information

### Product and service inquiries

Address any inquiries about the product to your local ABB representative, quoting the type designation and serial number of the unit in question. A listing of ABB sales, support and service contacts can be found by navigating to [www.abb.com/contact-centers](http://www.abb.com/contact-centers).

### Product training

For information on ABB product training, navigate to [new.abb.com/service/training](http://new.abb.com/service/training).

### Providing feedback on ABB manuals

Your comments on our manuals are welcome. Navigate to [forms.abb.com/form-26567](http://forms.abb.com/form-26567).

### Document library on the Internet

You can find manuals and other product documents in PDF format on the Internet at [www.abb.com/drives/documents](http://www.abb.com/drives/documents).



[www.abb.com/drives](http://www.abb.com/drives)



3AXD50001148140B