

ABB Motion product brochure

# HDS high performance explosion-proof servo motor

HX and HY series



---

# **High Accuracy, High Density, Safety, High Efficiency**

**Developed, designed, and produced strictly according to the most stringent standards, under both CCC and ATEX certification systems, ABB explosion-proof servo motors comply with the severe requirement from explosion-proof environment and enable safe applications for system integrators and equipment manufacturers.**

**Featuring in high energy efficiency level, compact dimension, rich options, and low current design, all derived from the deep experience of ABB in both general automation applications and hazardous environment applications, the HX and HY series explosion-proof servo motors enable customers in various industries with safe, reliable, and energy-saving solutions.**

---

# Table of contents

<b>Product overview and typical applications</b>	04
<b>How to select a servo system</b>	05
<b>HX explosion-proof markings description</b>	06
<b>HY explosion-proof markings description</b>	08
<b>HX explosion-proof servo motors</b>	10
Product highlights	10
Data sheet	12
Performance curves	25
Motor dimension	34
Interface definition	38
Nameplate and identifiers	39
<b>HY explosion-proof servo motors</b>	40
Product highlights	40
Data sheet	42
Performance curves	43
Motor dimension	45
Interface definition	49
Nameplate and identifiers	50
<b>Service environment</b>	51
<b>Product information</b>	52
Feedback & Thermal protection	52
<b>Ordering information</b>	53
HX and HY explosion-proof servo motors	53
Cable	54
<b>Drive</b>	56
MicroFlex e190	56
MotiFlex e180	60
<b>230 V product package combination</b>	64
<b>400 V product package combination</b>	70

# Product overview and typical applications

HX explosion-proof servo motor		
	ATEX	CCC
Explosion-proof zone	Zone 1/21	Zone 1/21
Explosion-proof signs	gas II 2 G Ex db IIC T5/T4 Gb	Ex db IIC T5/T4 Gb
	dust II 2 D Ex tb IIIC T100°C / T130°C Db IP66	Ex tb IIIC T100°C / T130°C Db IP66
Flange dimension	70 mm, 100 mm, 140 mm, 185 mm	
Rated torque/Peak torque	1.6...63 N·m/3.4...210 N·m	
Rated speed/Maximum speed	900...5000 rpm/900...5000 rpm	
Motor inertia	w/o brake 0.27...118.1 kg·cm <sup>2</sup>	
	w brake 0.28...125.1 kg·cm <sup>2</sup>	
Motor type	AC permanent magnet synchronous servo motor	
Cooling Method	Totally enclosed, non-ventilated	
Magnet Material	Ultra-high intrinsic coercive field rare earth	
Insulation Class	F	
Mounting	IMB5	
Thermal Protection	3 × PTC 155	
Exterior Paint	Epoxy	
Color	Motor body: Black	
	End-cover: White, with ABB logo	
Feedback Device	Resolver, Absolute encoder	
Ingress Protection	IP66	
Energy efficiency class	Level 1 or Level 2 energy efficiency (according to GB30253-2013)	
Standards	EN 60079-0: Explosive atmospheres - Part 0: Equipment - General requirements	GB/T 3836.1 « Explosive atmospheres Part 1: Equipment - General requirements »
	EN 60079-1: Explosive atmospheres - Part 1: Equipment protection by flameproof enclosures "d"	GB/T 3836.2 « Explosive atmospheres - Part 2: Equipment protection by flameproof enclosures "d" »
	EN 60079-31: Explosive atmospheres - Part 31: Equipment dust ignition protection by enclosure "t"	GB/T 3836.31 « Explosive atmospheres - Part 31: Equipment dust ignition protection by enclosure "t" »

HY explosion-proof servo motor		
	ATEX	CCC
Explosion-proof zone	Zone 2/22	Zone 2/21
Explosion-proof signs	gas II 3 G Ex ec IIC T4 Gc	Ex ec IIC T4 Gc
	dust II 3 D Ex tc IIIC T130°C Dc IP65	Ex tb IIIC T130°C Db IP65
Flange dimension	65 mm, 100 mm, 130 mm, 180 mm	
Rated torque/Peak torque	1.6...38.5 N·m/4.5...135 N·m	
Rated speed/Maximum speed	2000...3000 rpm/3500...5000 rpm	
Motor inertia	w/o brake 0.38...82.1 kg·cm <sup>2</sup>	
	w brake 0.41...89.2 kg·cm <sup>2</sup>	
Motor type	AC permanent magnet synchronous servo motor	
Cooling Method	Totally enclosed, non-ventilated	
Magnet Material	Ultra-high intrinsic coercive field rare earth	
Insulation Class	F	
Mounting	IMB5	
Thermal Protection	3 × PTC 140	
Exterior Paint	Epoxy	
Color	Motor body: Black	
	End-cover: White, with ABB logo	
Feedback Device	Resolver	
Ingress Protection	IP65	
Energy efficiency class	Level 1 energy efficiency (according to GB30253-2013)	
Standards	EN 60079-0: Explosive atmospheres - Part 0: Equipment - General requirements	GB/T 3836.1 « Explosive atmospheres Part 1: Equipment - General requirements »
	EN 60079-7: Explosive atmospheres - Part 7: Equipment protection by increased safety "e"	GB/T 3836.3 « Explosive atmospheres Part 3: Equipment protection by increased safety "e" »
	EN 60079-31: Explosive atmospheres - Part 31: Equipment dust ignition protection by enclosure "t"	GB/T 3836.31 « Explosive atmospheres - Part 31: Equipment dust ignition protection by enclosure "t" »

## Typical industries and applications



Oil and gas equipment



Pharmaceutical equipment



Spraying robot



Printing, food processing and other equipment

# How to select a servo system

## ABB servo product model selection steps

### Step 1: Select the servo motor

Calculate and verify the following technical data

- Torque
- Speed
- Rotary inertia
- Brake



See page 12, 42, and 53 for motor technical data and ordering information.

**HX explosion-proof servo motors**  
Data sheet T4

Power (kW)	Speed (rpm)	Current (A)	Torque (Nm)	Rotary inertia (kgm²)
0.5	1500	1.5	1.5	0.0001
0.75	1500	2.2	2.2	0.0001
1.0	1500	3.0	3.0	0.0001
1.5	1500	4.5	4.5	0.0001
2.0	1500	6.0	6.0	0.0001
3.0	1500	9.0	9.0	0.0001
4.0	1500	12.0	12.0	0.0001
5.5	1500	16.5	16.5	0.0001
7.5	1500	22.5	22.5	0.0001
10.0	1500	30.0	30.0	0.0001
15.0	1500	45.0	45.0	0.0001
20.0	1500	60.0	60.0	0.0001
30.0	1500	90.0	90.0	0.0001
40.0	1500	120.0	120.0	0.0001
55.0	1500	165.0	165.0	0.0001
75.0	1500	225.0	225.0	0.0001
100.0	1500	300.0	300.0	0.0001

**HY explosion-proof servo motors**  
Data sheet

Power (kW)	Speed (rpm)	Current (A)	Torque (Nm)	Rotary inertia (kgm²)
0.5	1500	1.5	1.5	0.0001
0.75	1500	2.2	2.2	0.0001
1.0	1500	3.0	3.0	0.0001
1.5	1500	4.5	4.5	0.0001
2.0	1500	6.0	6.0	0.0001
3.0	1500	9.0	9.0	0.0001
4.0	1500	12.0	12.0	0.0001
5.5	1500	16.5	16.5	0.0001
7.5	1500	22.5	22.5	0.0001
10.0	1500	30.0	30.0	0.0001
15.0	1500	45.0	45.0	0.0001
20.0	1500	60.0	60.0	0.0001
30.0	1500	90.0	90.0	0.0001
40.0	1500	120.0	120.0	0.0001
55.0	1500	165.0	165.0	0.0001
75.0	1500	225.0	225.0	0.0001
100.0	1500	300.0	300.0	0.0001

**Ordering information**  
HX and HY explosion-proof servo motors

1

2

### Step 2: Select the servo drive via the following technical data

- Current
- Input voltage
- Overload mode



See pages 56, 60, 64 and 70 for the drive configuration table and ordering information.

**Drive**  
MicroFlex e190

Power (kW)	Current (A)	Input voltage (V)	Overload mode
0.5	1.5	230	150%
0.75	2.2	230	150%
1.0	3.0	230	150%
1.5	4.5	230	150%
2.0	6.0	230	150%
3.0	9.0	230	150%
4.0	12.0	230	150%
5.5	16.5	230	150%
7.5	22.5	230	150%
10.0	30.0	230	150%
15.0	45.0	230	150%
20.0	60.0	230	150%
30.0	90.0	230	150%
40.0	120.0	230	150%
55.0	165.0	230	150%
75.0	225.0	230	150%
100.0	300.0	230	150%

**Drive**  
MotiFlex e180

Power (kW)	Current (A)	Input voltage (V)	Overload mode
0.5	1.5	230	150%
0.75	2.2	230	150%
1.0	3.0	230	150%
1.5	4.5	230	150%
2.0	6.0	230	150%
3.0	9.0	230	150%
4.0	12.0	230	150%
5.5	16.5	230	150%
7.5	22.5	230	150%
10.0	30.0	230	150%
15.0	45.0	230	150%
20.0	60.0	230	150%
30.0	90.0	230	150%
40.0	120.0	230	150%
55.0	165.0	230	150%
75.0	225.0	230	150%
100.0	300.0	230	150%

**230 V product package combination**

Power (kW)	Current (A)	Input voltage (V)	Overload mode
0.5	1.5	230	150%
0.75	2.2	230	150%
1.0	3.0	230	150%
1.5	4.5	230	150%
2.0	6.0	230	150%
3.0	9.0	230	150%
4.0	12.0	230	150%
5.5	16.5	230	150%
7.5	22.5	230	150%
10.0	30.0	230	150%
15.0	45.0	230	150%
20.0	60.0	230	150%
30.0	90.0	230	150%
40.0	120.0	230	150%
55.0	165.0	230	150%
75.0	225.0	230	150%
100.0	300.0	230	150%

**400 V product package combination**

Power (kW)	Current (A)	Input voltage (V)	Overload mode
0.5	1.5	400	150%
0.75	2.2	400	150%
1.0	3.0	400	150%
1.5	4.5	400	150%
2.0	6.0	400	150%
3.0	9.0	400	150%
4.0	12.0	400	150%
5.5	16.5	400	150%
7.5	22.5	400	150%
10.0	30.0	400	150%
15.0	45.0	400	150%
20.0	60.0	400	150%
30.0	90.0	400	150%
40.0	120.0	400	150%
55.0	165.0	400	150%
75.0	225.0	400	150%
100.0	300.0	400	150%

### Step 3: Select cables and optional parts / accessories

See page 54, page 59, and page 63 for the information of the cables and optional parts / accessories of the drive and motor.



3

4

### Step 4: Select the controller

- B&R X20
- ABB AC500
- Third party products



# HX explosion-proof markings description

## Explosion-proof zone and explosion-proof markings

Motor series	Environment type	Explosion-proof certification system	Explosion-proof zone	Explosion-proof markings
HX	Gas atmospheres	CCC	Zone 1	Ex db IIC T5/T4 Gb
	Dust atmospheres		Zone 21	Ex tb IIIC T100°C /T130°C Db IP66
	Gas atmospheres	ATEX	Zone 1	II 2 G Ex db IIC T5/T4 Gb
	Dust atmospheres		Zone 21	II 2 D Ex tb IIIC T100°C /T130°C Db IP66

## Explosion-proof zone

### Explosive gas atmospheres

Zone 0	Places where an explosive gas atmosphere occurs continuously or exists for a prolonged period of time.
Zone 1	Places where an explosive gas atmosphere is likely to occur during normal operations.
Zone 2	Places where an explosive gas atmosphere is unlikely to occur during normal operations, and even if it occurs, it is only occasional and only exists for a short period of time.

### Explosive dust atmospheres

Zone 20	Places where an explosive dust atmosphere occurs continuously or exists for a prolonged period of time.
Zone 21	Places where an explosive dust atmosphere is likely to occur during normal operations.
Zone 22	Places where an explosive dust atmosphere is unlikely to occur during normal operations, and even if it occurs, it is only occasional and only exists for a short period of time.

## Explosion-proof markings

### CCC explosion-proof certification system

#### Explosive gas atmospheres: Ex db IIC T5 / T4 Gb

HX series motors can meet the explosion-proof environment as: Zone 1 or Zone 2 explosion-proof, gas groups IIA, IIB and IIC, temperature level T1~T5.

Ex	db	II	C	T5 / T4	Gb
EX explosion-proof	db Flameproof enclosures	I Mine	Methane, coal dust	Maximum permissible surface temperature	Ma Very high protection level
	ec Increased safety			Tx or Txxx°C	Mb High protection level
	ic Intrinsic safety			Tx definition:	
	mc Encapsulation	II Ground	A Propane	T1: 450°C	Ga Very high protection level
	nA Non-sparking			T2: 300°C	
	nR Restricted breathing			T3: 200°C	
	nL Energy-limited			T4: 135°C	Gb High protection level
	o Oil immersion			T5: 100°C	
	pz Pressurization			T6: 85°C	Gc General protection level
	q Powder filling				

# HX explosion-proof markings description

## Explosive dust atmospheres: Ex tb IIIC T100°C / T130°C Db IP66

HX series motors can meet the explosion-proof environment as: Zone 21 or Zone 22 explosion-proof, dust groups IIIA, IIIB and IIIC, temperature level T1~T100°C, protection level IP66.

Ex	tb	III	C	T100°C / T130°C	Db
EX explosion-proof	tb Protection by enclosure ic Intrinsic safety mc Encapsulation p Pressurization	III Ground	A Conductive	Maximum permissible surface temperature Tx or Txxx°C Tx definition: T1: 450°C T2: 300°C T3: 200°C T4: 135°C T5: 100°C	Da Very high protection level
			B Non-conductive dust	T130°C T100°C	Db High protection level
			C Conductive dust	T6: 85°C	Dc General protection level

## ATEX explosion-proof certification system

### Explosive gas atmospheres: II 2 G Ex db IIC T5 / T4 Gb

HX series motors can meet the explosion-proof environment as: Zone 1 or Zone 2 explosion-proof, gas groups IIA, IIB and IIC, temperature level T1~T5.

II	2	G	Ex	db	II	C	T5 / T4	Gb
I Mine	M1 Very high protection level	G explosive gases	EX explosion-proof	db Flameproof enclosures	I Mine	Methane, coal dust	Maximum permissible surface temperature Tx or Txxx°C Tx definition: T1: 450°C T2: 300°C T3: 200°C T4: 135°C T5: 100°C T6: 85°C	Ma Very high protection level
	M2 High protection level			ec Increased safety ic Intrinsic safety mc Encapsulation				Mb High protection level
II Ground	1 Very high protection level			G explosive gases	EX explosion-proof	nA Non-sparking nR Restricted breathing nL Energy-limited o Oil immersion pz Pressurization q Powder filling	II Ground	A Propane
	2 High protection level	B Ethylene	Gb High protection level					
	3 General protection level	C Hydrogen, acetylene	Gc General protection level					

### Explosive dust atmospheres: II 2 D Ex tb IIIC T100°C / T130°C Db IP66

HX series motors can meet the explosion-proof environment as: Zone 21 or Zone 22 explosion-proof, dust groups IIIA, IIIB and IIIC, temperature level T1~T100°C, protection level IP66.

II	2	D	Ex	tb	III	C	T100°C / T130°C	Db
II Ground	1 Very high protection level	D explosive dust	EX explosion-proof	tb Protection by enclosure ic Intrinsic safety mc Encapsulation p Pressurization	III Ground	A Conductive	Maximum permissible surface temperature Tx or Txxx°C Tx definition: T1: 450°C T2: 300°C T3: 200°C T4: 135°C T5: 100°C	Da Very high protection level
	2 High protection level					B Non-conductive dust	T130°C T100°C	Db High protection level
	3 General protection level					C Conductive dust	T6: 85°C	Dc General protection level

# HY explosion-proof markings description

## Explosion-proof zone and explosion-proof markings

Motor series	Environment type	Explosion-proof certification system	Explosion-proof zone	Explosion-proof markings
HY	Gas atmospheres	CCC	Zone 2	Ex ec IIC T4 Gc
	Dust atmospheres		Zone 21	Ex tb IIIC T130°C Db IP65
	Gas atmospheres	ATEX	Zone 2	II 3 G Ex ec IIC T4 Gc
	Dust atmospheres		Zone 22	II 3 D Ex tc IIIC T130°C Dc IP65

## Explosion-proof zone

### Explosive gas atmospheres

Zone 0	Places where an explosive gas atmosphere occurs continuously or exists for a prolonged period of time.
Zone 1	Places where an explosive gas atmosphere is likely to occur during normal operations.
Zone 2	Places where an explosive gas atmosphere is unlikely to occur during normal operations, and even if it occurs, it is only occasional and only exists for a short period of time.

### Explosive dust atmospheres

Zone 20	Places where an explosive dust atmosphere occurs continuously or exists for a prolonged period of time.
Zone 21	Places where an explosive dust atmosphere is likely to occur during normal operations.
Zone 22	Places where an explosive dust atmosphere is unlikely to occur during normal operations, and even if it occurs, it is only occasional and only exists for a short period of time.

## Explosion-proof markings

### CCC explosion-proof certification system

#### Explosive gas atmospheres: Ex ec IIC T4 Gc

HY series motors can meet the explosion-proof environment as: Zone 2 explosion-proof, gas groups IIA, IIB and IIC, temperature level T1~T4.

Ex	ec	II	C	T4	Gc
EX explosion-proof	db Flameproof enclosures	I Mine	Methane, coal dust	Maximum permissible surface temperature	Ma Very high protection level
	ec Increased safety			Tx or Txxx°C	Mb High protection level
	ic Intrinsic safety			Tx definition:	
	mc Encapsulation			T1: 450°C	Ga Very high protection level
	nA Non-sparking	II Ground	A Propane	T2: 300°C	
	nR Restricted breathing			T3: 200°C	Gb High protection level
	nL Energy-limited			T4: 135°C	
	o Oil immersion			T5: 100°C	
pz Pressurization	C Hydrogen, acetylene		T6: 85°C	Gc General protection level	
q Powder filling					

# HY explosion-proof markings description

## Explosive dust atmospheres: Ex tb IIIC T130°C Db IP65

HY series motors can meet the explosion-proof environment as: Zone 21 or Zone 22 explosion-proof, dust groups IIIA, IIIB and IIIC, temperature level T1~T130°C, protection level IP65.

Ex	tb	III	C	T130°C	Db
EX explosion-proof	tb Protection by enclosure ic Intrinsic safety mc Encapsulation p Pressurization	III Ground	A Conductive	Maximum permissible surface temperature Tx or Txxx°C Tx definition: T1: 450°C T2: 300°C T3: 200°C T4: 135°C	Da Very high protection level
			B Non-conductive dust	T130°C T5: 100°C T6: 85°C	Db High protection level
			C Conductive dust		Dc General protection level

## ATEX explosion-proof certification system

### Explosive gas atmospheres: II 3 G Ex ec IIC T4 Gc

HY series motors can meet the explosion-proof environment as: Zone 2 explosion-proof, gas groups IIA, IIB and IIC, temperature level T1~T4.

II	3	G	Ex	ec	II	C	T4	Gc
I Mine	M1 Very high protection level	G explosive gases	EX explosion-proof	db Flameproof enclosures	I Mine	Methane, coal dust	Maximum permissible surface temperature Tx or Txxx°C Tx definition: T1: 450°C T2: 300°C T3: 200°C T4: 135°C	Ma Very high protection level
	M2 High protection level			ec Increased safety				Mb High protection level
II Ground	1 Very high protection level			nA Non-sparking	Gc General protection level	A Propane	II Ground	B Ethylene C Hydrogen, acetylene
	2 High protection level	nR Restricted breathing	T2: 300°C	Gb High protection level				
	3 General protection level	nL Energy-limited o Oil immersion pz Pressurization q Powder filling	T3: 200°C T4: 135°C T5: 100°C T6: 85°C					

### Explosive dust atmospheres: II 3 D Ex tc IIIC T130°C Dc IP65

HY series motors can meet the explosion-proof environment as: Zone 22 explosion-proof, dust groups IIIA, IIIB and IIIC, temperature level T1~T130°C, protection level IP65.

II	3	D	Ex	tc	III	C	T130°C	Dc
II Ground	1 Very high protection level	D explosive dust	EX explosion-proof	tc Protection by enclosure ic Intrinsic safety mc Encapsulation p Pressurization	III Ground	A Conductive	Maximum permissible surface temperature Tx or Txxx°C Tx definition: T1: 450°C T2: 300°C T3: 200°C T4: 135°C	Da Very high protection level
	2 High protection level					B Non-conductive dust	T130°C T5: 100°C T6: 85°C	Db High protection level
	3 General protection level					C Conductive dust		Dc General protection level

# HX explosion-proof servo motors

## Product highlights

HX explosion-proof servo motors has brand-new explosion-proof structure design, optimized winding types, and more feedback options. Certified for explosion-proof for Zone 1, HX is specifically tailored for environments requiring higher levels of explosion protection. It employs a flameproof explosion-proof design to ensure the motor casing that withstands internal explosions in gas and dust explosion scenarios without damage, guaranteeing equipment safety. The explosion-proof performance complies with standards, with CCC explosion-proof markings as Ex db IIC T5 / T4 Gb and Ex tb IIIC T100°C / T130°C Db IP66, and ATEX markings as II 2 G Ex db IIC T5/T4 Gb and II 2 D Ex tb IIIC T100°C / T130°C Db IP66.



— High torque density and power density: reduced volume and weight.



— High torque constant, low current design, comprehensive consideration of overall solutions, controlling system costs.



— Low cogging torque and torque ripple: excellent performance at low speed and system control. Fast dynamic response, accurate rotor balance.



— Outstanding overload performance: 3 times peak torque, 4 times mechanical overload capacity.





— Brake optional. Resolvers are standard accessories. Cable kits are available, or you can purchase standard cable connectors.



— Epoxy resin potting technology on complete stator: compact size and better heat dissipation.



— High-precision machining technology, more precise engagement between the flange and rotating shaft to ensure less noise and vibration.



— Various winding types designed for the stator to achieve different speeds and torques. Double-layer winding process with fully insulated neutral point connections inside the casing ensures safety.

# HX explosion-proof servo motors

## Data sheet T4

### Rated voltage level AC230 V, temperature class T4

Frame size		HXA70					
Model		5030A	7345A	6930A	9445A	8530A	1145A
Rated power	kW	0.50	0.73	0.69	0.94	0.85	1.15
<b>General</b>							
Input voltage	VAC	230	230	230	230	230	230
Rated torque	N·m	1.6	1.55	2.2	2	2.72	2.43
Peak torque	N·m	3.4	3.4	5.2	5.2	7	7
Continuous stall torque	N·m	1.7	1.7	2.4	2.4	3	3
Rated current	$A_{rms}$	2.3	3.1	2.9	3.8	3.9	5
Peak current	$A_{rms}$	6	8.5	8.5	12	12	17
Continuous stall current	$A_{rms}$	2.3	3.3	3	4.3	4.1	5.9
Rated speed	rpm	3000	4500	3000	4500	3000	4500
<b>Electrical</b>							
Torque constant <sup>1)</sup>	$N·m/A_{rms}$	0.83	0.58	0.87	0.62	0.83	0.58
Voltage constant	$V_{rms}/krpm$	50	35	52.8	37.5	50	34.8
Line resistance	Ohms	8.6	4.2	5.8	2.9	3.8	1.9
Line inductance	mH	30	14.8	21.7	11	14.6	7.2
Electrical time constant	ms	3.5	3.5	3.7	3.8	3.8	3.8
<b>Mechanical</b>							
Rotor inertia with brake	$kg·cm^2$	0.28	0.28	0.40	0.40	0.52	0.52
Rotor inertia w/o brake	$kg·cm^2$	0.27	0.27	0.39	0.39	0.51	0.51
Mechanical time constant	ms	0.3	0.3	0.3	0.3	0.2	0.3
Number of poles	-	10	10	10	10	10	10
Motor weight with brake	kg	2.74	2.74	3.03	3.03	3.31	3.31
Motor weight w/o brake	kg	2.28	2.28	2.57	2.57	2.84	2.84
Thermal time constant	min	10	10	20	20	26	26
Maximum radial load (@LF <sup>2)</sup> )	N	200 (@11.5 mm)					
Maximum axial load <sup>2)</sup>	N	130					
<b>Ambient</b>							
Insulation class	-	F					
Operating temperature	°C	-20...40					
Operating humidity	%	5~95 (no dews)					
Storage temperature	°C	-40...50					
<b>Brake parameters</b>							
Voltage	VDC ± 10%	24	24	24	24	24	24
Current	A	0.34	0.34	0.34	0.34	0.34	0.34
Power	W	8.2	8.2	8.2	8.2	8.2	8.2
Static torque	N·m (min)	2	2	2	2	2	2
Pull-in time	ms (max)	40	40	40	40	40	40
Release time	ms (max)	60	60	60	60	60	60

Notes: 1) The torque constant decreases in a non-linear manner as the torque increases, the values are considered valid until approximately 2 times cont. stall torque.  
 2) The allowable load of the shaft is shown in the figure below. In mechanical design, radial and axial loads in servo motor operation should be prevented from exceeding the values in the table. Values are based on an estimate of the combined load capacity of bearing at rated speed. For detailed bearing load capacity data, please contact ABB.

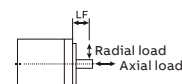





# HX explosion-proof servo motors

## Data sheet T4

### Rated voltage level AC230 V, temperature class T4

Frame size		HXA18					
Model		5011A	7520A	6211A	9020A	6809A	9915A
Rated power	kW	5.0	7.5	6.2	9.0	6.8	9.9
<b>General</b>							
Input voltage	VAC	230	230	230	230	230	230
Rated torque	N·m	42	36	52	43	72.5	63
Peak torque	N·m	105	105	140	140	210	210
Continuous stall torque	N·m	50	50	65	65	87	87
Rated current	$A_{rms}$	21	31.5	25.5	43	31	40.5
Peak current	$A_{rms}$	51.3	90.6	70.3	137.6	93	137.6
Continuous stall current	$A_{rms}$	23.3	41.2	30.4	60	35.5	52.5
Rated speed	rpm	1150	2000	1150	2000	900	1500
<b>Electrical</b>							
Torque constant <sup>1)</sup>	$N·m/A_{rms}$	2.3	1.3	2.3	1.1	2.6	1.7
Voltage constant	$V_{rms}/krpm$	140.1	79.4	140.1	71.6	158.8	107.4
Line resistance	Ohms	0.3	0.1	0.2	0.1	0.2	0.1
Line inductance	mH	5.6	1.8	4.2	1.1	3.5	1.6
Electrical time constant	ms	16.3	16.3	17.0	16.7	19.0	17.6
<b>Mechanical</b>							
Rotor inertia with brake	$kg·cm^2$	68.3	68.3	87.2	87.2	125.1	125.1
Rotor inertia w/o brake	$kg·cm^2$	61.3	61.3	80.2	80.2	118.1	118.1
Mechanical time constant	ms	0.3	0.3	0.3	0.4	0.3	0.3
Number of poles	-	10	10	10	10	10	10
Motor weight with brake	kg	30.1	30.1	33.2	33.2	51.8	51.8
Motor weight w/o brake	kg	24.2	24.2	27.5	27.5	46.1	46.1
Thermal time constant	min	47	47	50	50	59	59
Maximum radial load (@LF <sup>2)</sup> )	N	1000 (@30 mm)					
Maximum axial load <sup>2)</sup>	N	500					
<b>Ambient</b>							
Insulation class	-	F					
Operating temperature	°C	-20...40					
Operating humidity	%	5~95 (no dews)					
Storage temperature	°C	-40...50					
<b>Brake parameters</b>							
Voltage	VDC ± 10%	24	24	24	24	24	24
Current	A	1.50	1.50	1.50	1.50	1.50	1.50
Power	W	36	36	36	36	36	36
Static torque	N·m (min)	60	60	60	60	60	60
Pull-in time	ms (max)	60	60	60	60	60	60
Release time	ms (max)	260	260	260	260	260	260

# HX explosion-proof servo motors

## Data sheet T4

### Rated voltage level AC400 V, temperature class T4

Frame size		HXA70			HXA10				
Model		7950B	1050B	1250B	1850B	2350B	1830B	2330B	2943B
Rated power	kW	0.79	1.02	1.24	1.88	2.36	1.82	2.36	2.93
<b>General</b>									
Input voltage	VAC	400	400	400	400	400	400	400	400
Rated torque	N·m	1.5	1.95	2.36	3.6	4.5	5.8	7.5	6.5
Peak torque	N·m	3.4	5.2	7	11.8	17.7	17.7	23.6	23.6
Continuous stall torque	N·m	1.7	2.4	3	5.3	7.1	7.1	9	9
Rated current	A <sub>rms</sub>	2.1	2.6	3.5	4.9	6.8	5	5.6	6.5
Peak current	A <sub>rms</sub>	6	8.5	12	19.1	30.5	18.5	22.8	36.9
Continuous stall current	A <sub>rms</sub>	2.3	3	4.1	6.5	9.5	5.8	6.5	10.5
Rated speed	rpm	5000	5000	5000	5000	5000	3000	3000	4300
<b>Electrical</b>									
Torque constant <sup>1)</sup>	N·m/A <sub>rms</sub>	0.83	0.87	0.83	0.9	0.85	1.41	1.52	0.95
Voltage constant	V <sub>rms</sub> /krpm	50	52.8	50	54.7	51.5	85.1	92.2	57.2
Line resistance	Ohms	8.6	5.8	3.8	1.8	1	2.6	2.1	0.84
Line inductance	mH	30	21.7	14.6	13	7.6	20.8	17.5	6.7
Electrical time constant	ms	3.5	3.7	3.8	7.2	7.6	8.0	8.3	8.0
<b>Mechanical</b>									
Rotor inertia with brake	kg·cm <sup>2</sup>	0.28	0.40	0.52	1.42	1.97	1.97	2.52	2.52
Rotor inertia w/o brake	kg·cm <sup>2</sup>	0.27	0.39	0.51	1.29	1.84	1.84	2.39	2.39
Mechanical time constant	ms	0.3	0.3	0.2	0.3	0.2	0.2	0.2	0.2
Number of poles	-	10	10	10	10	10	10	10	10
Motor weight with brake	kg	2.74	3.03	3.31	5.31	5.92	5.92	6.53	6.53
Motor weight w/o brake	kg	2.28	2.57	2.84	4.74	5.36	5.36	5.97	5.97
Thermal time constant	min	10	20	26	12	25	25	27	27
Maximum radial load (@LF <sup>2)</sup> )	N	200 (@11.5 mm)			470 (@20 mm)				
Maximum axial load <sup>2)</sup>	N	130			250				
<b>Ambient</b>									
Insulation class	-	F			F				
Operating temperature	°C	-20...40			-20...40				
Operating humidity	%	5~95 (no dews)			5~95 (no dews)				
Storage temperature	°C	-40...50			-40...50				
<b>Brake parameters</b>									
Voltage	VDC ± 10%	24	24	24	24	24	24	24	24
Current	A	0.34	0.34	0.34	0.82	0.82	0.82	0.82	0.82
Power	W	8.2	8.2	8.2	19.6	19.6	19.6	19.6	19.6
Static torque	N·m (min)	2	2	2	7	7	7	7	7
Pull-in time	ms (max)	40	40	40	40	40	40	40	40
Release time	ms (max)	60	60	60	100	100	100	100	100



# HX explosion-proof servo motors

## Data sheet T4

### Rated voltage level AC400 V, temperature class T4

Frame size		HXA18					
Model		7520B	8735B	9020B	9430B	9815B	1225B
Rated power	kW	7.5	8.8	9.0	9.4	9.9	12.0
<b>General</b>							
Input voltage	VAC	400	400	400	400	400	400
Rated torque	N·m	36	24	43	30	63	46
Peak torque	N·m	105	105	140	140	210	210
Continuous stall torque	N·m	50	50	65	65	87	87
Rated current	$A_{rms}$	17.9	20.5	21.2	30	27	29.6
Peak current	$A_{rms}$	51.3	90.6	70.3	137.6	93	137.6
Continuous stall current	$A_{rms}$	23.3	41.2	30.4	60	35.5	52.5
Rated speed	rpm	2000	3500	2000	3000	1500	2500
<b>Electrical</b>							
Torque constant <sup>1)</sup>	$N\cdot m/A_{rms}$	2.3	1.3	2.3	1.1	2.6	1.7
Voltage constant	$V_{rms}/krpm$	140.1	79.4	140.1	71.6	158.8	107.4
Line resistance	Ohms	0.3	0.1	0.2	0.1	0.2	0.1
Line inductance	mH	5.6	1.8	4.2	1.1	3.5	1.6
Electrical time constant	ms	16.3	16.3	17.0	16.7	19.0	17.6
<b>Mechanical</b>							
Rotor inertia with brake	$kg\cdot cm^2$	68.3	68.3	87.2	87.2	125.1	125.1
Rotor inertia w/o brake	$kg\cdot cm^2$	61.3	61.3	80.2	80.2	118.1	118.1
Mechanical time constant	ms	0.3	0.3	0.3	0.4	0.3	0.3
Number of poles	-	10	10	10	10	10	10
Motor weight with brake	kg	30.1	30.1	33.2	33.2	51.8	51.8
Motor weight w/o brake	kg	24.2	24.2	27.5	27.5	46.1	46.1
Thermal time constant	min	47	47	50	50	59	59
Maximum radial load (@LF <sup>2)</sup> )	N	1000 (@30mm)					
Maximum axial load <sup>2)</sup>	N	500					
<b>Ambient</b>							
Insulation class	-	F					
Operating temperature	°C	-20...40					
Operating humidity	%	5~95 (no dews)					
Storage temperature	°C	-40...50					
<b>Brake parameters</b>							
Voltage	VDC ± 10%	24	24	24	24	24	24
Current	A	1.50	1.50	1.50	1.50	1.50	1.50
Power	W	36	36	36	36	36	36
Static torque	N·m (min)	60	60	60	60	60	60
Pull-in time	ms (max)	60	60	60	60	60	60
Release time	ms (max)	260	260	260	260	260	260

# HX explosion-proof servo motors

## Data sheet T5

### Rated voltage level AC230 V, temperature class T5

Frame size		HXA70					
Model		4730A	6145A	5730A	6645A	6630A	7545A
Rated power	kW	0.47	0.61	0.57	0.66	0.66	0.75
<b>General</b>							
Input voltage	VAC	230	230	230	230	230	230
Rated torque	N·m	1.5	1.3	1.8	1.4	2.1	1.6
Peak torque	N·m	3.4	3.4	5.2	5.2	7	7
Continuous stall torque	N·m	1.6	1.6	2.2	2.2	2.7	2.7
Rated current	$A_{rms}$	1.9	2.6	2.3	2.7	2.9	3.2
Peak current	$A_{rms}$	6	8.5	8.5	12	12	17
Continuous stall current	$A_{rms}$	2.1	3	2.7	3.8	3.6	5.1
Rated speed	rpm	3000	4500	3000	4500	3000	4500
<b>Electrical</b>							
Torque constant <sup>1)</sup>	$N·m/A_{rms}$	0.83	0.58	0.87	0.62	0.83	0.58
Voltage constant	$V_{rms}/krpm$	50	35	52.8	37.5	50	34.8
Line resistance	Ohms	8.6	4.2	5.8	2.9	3.8	1.9
Line inductance	mH	30	14.8	21.7	11	14.6	7.2
Electrical time constant	ms	3.5	3.5	3.7	3.8	3.8	3.8
<b>Mechanical</b>							
Rotor inertia with brake	$kg·cm^2$	0.28	0.28	0.40	0.40	0.52	0.52
Rotor inertia w/o brake	$kg·cm^2$	0.27	0.27	0.39	0.39	0.51	0.51
Mechanical time constant	ms	0.3	0.3	0.3	0.3	0.2	0.3
Number of poles	-	10	10	10	10	10	10
Motor weight with brake	kg	2.74	2.74	3.03	3.03	3.31	3.31
Motor weight w/o brake	kg	2.28	2.28	2.57	2.57	2.84	2.84
Thermal time constant	min	10	10	20	20	26	26
Maximum radial load (@LF <sup>2)</sup> )	N	200 (@11.5 mm)					
Maximum axial load <sup>2)</sup>	N	130					
<b>Ambient</b>							
Insulation class	-	F					
Operating temperature	°C	-20...40					
Operating humidity	%	5~95 (no dews)					
Storage temperature	°C	-40...50					
<b>Brake parameters</b>							
Voltage	VDC ± 10%	24	24	24	24	24	24
Current	A	0.34	0.34	0.34	0.34	0.34	0.34
Power	W	8.2	8.2	8.2	8.2	8.2	8.2
Static torque	N·m (min)	2	2	2	2	2	2
Pull-in time	ms (max)	40	40	40	40	40	40
Release time	ms (max)	60	60	60	60	60	60

# HX explosion-proof servo motors

## Data sheet T5

### Rated voltage level AC230 V, temperature class T5

Frame size		HXA10				
Model		9430A	1130A	8717A	1017A	1325A
Rated power	kW	0.94	1.16	0.87	1.07	1.31
<b>General</b>						
Input voltage	VAC	230	230	230	230	230
Rated torque	N·m	3	3.7	4.8	5.9	5
Peak torque	N·m	11.8	17.7	17.7	23.6	23.6
Continuous stall torque	N·m	4.9	6.1	6.1	7.8	7.8
Rated current	A <sub>rms</sub>	3.5	4.9	3.9	4.2	5.8
Peak current	A <sub>rms</sub>	19.1	30.5	18.5	22.8	36.9
Continuous stall current	A <sub>rms</sub>	5.7	7.8	4.7	5.5	8.8
Rated speed	rpm	3000	3000	1725	1725	2500
<b>Electrical</b>						
Torque constant <sup>1)</sup>	N·m/A <sub>rms</sub>	0.9	0.85	1.41	1.52	0.95
Voltage constant	V <sub>rms</sub> /krpm	54.7	51.5	85.1	92.2	57.2
Line resistance	Ohms	1.8	1	2.6	2.1	0.84
Line inductance	mH	13	7.6	20.8	17.5	6.7
Electrical time constant	ms	7.2	7.6	8.0	8.3	8.0
<b>Mechanical</b>						
Rotor inertia with brake	kg·cm <sup>2</sup>	1.42	1.97	1.97	2.52	2.52
Rotor inertia w/o brake	kg·cm <sup>2</sup>	1.29	1.84	1.84	2.39	2.39
Mechanical time constant	ms	0.3	0.2	0.2	0.2	0.2
Number of poles	-	10	10	10	10	10
Motor weight with brake	kg	5.31	5.92	5.92	6.53	6.53
Motor weight w/o brake	kg	4.74	5.36	5.36	5.97	5.97
Thermal time constant	min	12	25	25	27	27
Maximum radial load (@LF <sup>2)</sup> )	N	470 (@20 mm)				
Maximum axial load <sup>2)</sup>	N	250				
<b>Ambient</b>						
Insulation class	-	F				
Operating temperature	°C	-20...40				
Operating humidity	%	5~95 (no dews)				
Storage temperature	°C	-40...50				
<b>Brake parameters</b>						
Voltage	VDC ± 10%	24	24	24	24	24
Current	A	0.82	0.82	0.82	0.82	0.82
Power	W	19.6	19.6	19.6	19.6	19.6
Static torque	N·m (min)	7	7	7	7	7
Pull-in time	ms (max)	40	40	40	40	40
Release time	ms (max)	100	100	100	100	100



# HX explosion-proof servo motors

## Data sheet T5

### Rated voltage level AC230 V, temperature class T5

Frame size		HXA18					
Model		4111A	5820A	4711A	5315A	5109A	6115A
Rated power	kW	4.2	5.9	4.8	5.3	5.1	6.1
<b>General</b>							
Input voltage	VAC	230	230	230	230	230	230
Rated torque	N·m	34.8	28	39.6	34	54.2	39
Peak torque	N·m	105	105	140	140	210	210
Continuous stall torque	N·m	44	44	58	58	77	77
Rated current	$A_{rms}$	17.4	24.5	18.6	31.5	22.9	24.5
Peak current	$A_{rms}$	51.3	90.6	70.3	137.6	93	137.6
Continuous stall current	$A_{rms}$	20.2	35.5	26.8	52.3	31.2	46
Rated speed	rpm	1150	2000	1150	1500	900	1500
<b>Electrical</b>							
Torque constant <sup>1)</sup>	$N·m/A_{rms}$	2.3	1.3	2.3	1.1	2.6	1.7
Voltage constant	$V_{rms}/krpm$	140.1	79.4	140.1	71.6	158.8	107.4
Line resistance	Ohms	0.3	0.1	0.2	0.1	0.2	0.1
Line inductance	mH	5.6	1.8	4.2	1.1	3.5	1.6
Electrical time constant	ms	16.3	16.3	17.0	16.7	19.0	17.6
<b>Mechanical</b>							
Rotor inertia with brake	$kg·cm^2$	68.3	68.3	87.2	87.2	125.1	125.1
Rotor inertia w/o brake	$kg·cm^2$	61.3	61.3	80.2	80.2	118.1	118.1
Mechanical time constant	ms	0.3	0.3	0.3	0.4	0.3	0.3
Number of poles	-	10	10	10	10	10	10
Motor weight with brake	kg	30.1	30.1	33.2	33.2	51.8	51.8
Motor weight w/o brake	kg	24.2	24.2	27.5	27.5	46.1	46.1
Thermal time constant	min	47	47	50	50	59	59
Maximum radial load (@LF <sup>2)</sup> )	N	1000 (@30 mm)					
Maximum axial load <sup>2)</sup>	N	500					
<b>Ambient</b>							
Insulation class	-	F					
Operating temperature	°C	-20...40					
Operating humidity	%	5~95 (no dews)					
Storage temperature	°C	-40...50					
<b>Brake parameters</b>							
Voltage	VDC ± 10%	24	24	24	24	24	24
Current	A	1.50	1.50	1.50	1.50	1.50	1.50
Power	W	36	36	36	36	36	36
Static torque	N·m (min)	60	60	60	60	60	60
Pull-in time	ms (max)	60	60	60	60	60	60
Release time	ms (max)	260	260	260	260	260	260

# HX explosion-proof servo motors

## Data sheet T5

### Rated voltage level AC400 V, temperature class T5

Frame size		HXA70			HXA10		
Model		6850B	7150B	7050B	9430B	1130B	1430B
Rated power	kW	0.68	0.71	0.68	0.94	1.16	1.41
<b>General</b>							
Input voltage	VAC	400	400	400	400	400	400
Rated torque	N·m	1.3	1.35	1.3	3	3.7	4.5
Peak torque	N·m	3.4	5.2	7	11.8	17.7	23.6
Continuous stall torque	N·m	1.6	2.2	2.7	4.9	6.1	7.8
Rated current	$A_{rms}$	1.8	1.8	1.9	3.5	3	3.3
Peak current	$A_{rms}$	6	8.5	12	19.1	18.5	22.8
Continuous stall current	$A_{rms}$	2.1	2.7	3.6	5.7	4.7	5.5
Rated speed	rpm	5000	5000	5000	3000	3000	3000
<b>Electrical</b>							
Torque constant <sup>1)</sup>	$N·m/A_{rms}$	0.83	0.87	0.83	0.9	1.41	1.52
Voltage constant	$V_{rms}/krpm$	50	52.8	50	54.7	85.1	92.2
Line resistance	Ohms	8.6	5.8	3.8	1.8	2.6	2.1
Line inductance	mH	30	21.7	14.6	13	20.8	17.5
Electrical time constant	ms	3.5	3.7	3.8	7.2	8.0	8.3
<b>Mechanical</b>							
Rotor inertia with brake	$kg·cm^2$	0.28	0.40	0.52	1.42	1.97	2.52
Rotor inertia w/o brake	$kg·cm^2$	0.27	0.39	0.51	1.29	1.84	2.39
Mechanical time constant	ms	0.3	0.3	0.2	0.3	0.2	0.2
Number of poles	-	10	10	10	10	10	10
Motor weight with brake	kg	2.74	3.03	3.31	5.31	5.92	6.53
Motor weight w/o brake	kg	2.28	2.57	2.84	4.74	5.36	5.97
Thermal time constant	min	10	20	26	12	25	27
Maximum radial load (@LF <sup>2)</sup> )	N	200 (@11.5 mm)			470 (@20 mm)		
Maximum axial load <sup>2)</sup>	N	130			250		
<b>Ambient</b>							
Insulation class	-	F			F		
Operating temperature	°C	-20...40			-20...40		
Operating humidity	%	5~95 (no dews)			5~95% (no dews)		
Storage temperature	°C	-40...50			-40...50		
<b>Brake parameters</b>							
Voltage	VDC ± 10%	24	24	24	24	24	24
Current	A	0.34	0.34	0.34	0.82	0.82	0.82
Power	W	8.2	8.2	8.2	19.6	19.6	19.6
Static torque	N·m (min)	2	2	2	7	7	7
Pull-in time	ms (max)	40	40	40	40	40	40
Release time	ms (max)	60	60	60	100	100	100

# HX explosion-proof servo motors

## Data sheet T5

### Rated voltage level AC400 V, temperature class T5

Frame size		HXA14					HXA18				
Model		1820B	2030B	2130B	2020B	1920B	5820B	5920B	5315B	6015B	6115B
Rated power	kW	1.9	2.1	2.1	2.1	1.9	5.9	5.9	5.3	6.1	6.1
<b>General</b>											
Input voltage	VAC	400	400	400	400	400	400	400	400	400	400
Rated torque	N·m	9	6.8	6.8	10	9	28	28	34	39	39
Peak torque	N·m	36	36	36	48	70	105	105	140	210	210
Continuous stall torque	N·m	12	12	12	16	19	44	44	58	77	77
Rated current	A <sub>rms</sub>	4.8	5.5	7.4	5.2	5.5	14	24.5	16	16.5	24.5
Peak current	A <sub>rms</sub>	20.5	30.6	41.1	30.2	44	51.3	90.6	70.3	93	137.6
Continuous stall current	A <sub>rms</sub>	6	9	12	8.1	10.5	20.2	35.5	26.8	31.2	46
Rated speed	rpm	2000	3000	3000	2000	2000	2000	2000	1500	1500	1500
<b>Electrical</b>											
Torque constant <sup>1)</sup>	N·m/A <sub>rms</sub>	2.1	1.4	1	2.1	2.1	2.3	1.3	2.3	2.6	1.7
Voltage constant	V <sub>rms</sub> /krpm	127	85.3	63.5	127	127	140.1	79.4	140.1	158.8	107.4
Line resistance	Ohms	1.9	0.8	0.5	1.2	0.8	0.3	0.1	0.2	0.2	0.1
Line inductance	mH	17	7.7	4.3	12	8	5.6	1.8	4.2	3.5	1.6
Electrical time constant	ms	9.0	9.5	8.8	9.6	9.9	16.3	16.3	17.0	19.0	17.6
<b>Mechanical</b>											
Rotor inertia with brake	kg·cm <sup>2</sup>	9.29	9.29	9.29	11.6	16.2	68.3	68.3	87.2	125.1	125.1
Rotor inertia w/o brake	kg·cm <sup>2</sup>	7.46	7.46	7.46	9.75	14.3	61.3	61.3	80.2	118.1	118.1
Mechanical time constant	ms	0.3	0.3	0.3	0.2	0.2	0.3	0.3	0.3	0.3	0.3
Number of poles	-	10	10	10	10	10	10	10	10	10	10
Motor weight with brake	kg	13.3	13.3	13.3	15.1	18.4	30.1	30.1	33.2	51.8	51.8
Motor weight w/o brake	kg	11.4	11.4	11.4	13.2	16.5	24.2	24.2	27.5	46.1	46.1
Thermal time constant	min	58	58	58	54	40	47	47	50	59	59
Maximum radial load (@LF <sup>2)</sup> )	N	550 (@25mm)					1000 (@30mm)				
Maximum axial load <sup>2)</sup>	N	250					500				
<b>Ambient</b>											
Insulation class	-	F					F				
Operating temperature	°C	-20...40					-20...40				
Operating humidity	%	5~95 (no dews)					5~95 (no dews)				
Storage temperature	°C	-40...50					-40...50				
<b>Brake parameters</b>											
Voltage	VDC ± 10%	24	24	24	24	24	24	24	24	24	24
Current	A	0.96	0.96	0.96	0.96	0.96	1.50	1.50	1.50	1.50	1.50
Power	W	23	23	23	23	23	36	36	36	36	36
Static torque	N·m (min)	25	25	25	25	25	60	60	60	60	60
Pull-in time	ms (max)	40	40	40	40	40	60	60	60	60	60
Release time	ms (max)	120	120	120	120	120	260	260	260	260	260

# HX explosion-proof servo motors

## Performance curves

### Motor performance curves and operation areas

The operation area of HDS servo motors is defined by performance curves in a 2-dimensional plane with coordinates of output torque and rotation speed. The performance curves of each type divide the operation area into continuous operation area and intermittent operation area.

- Continuous operation area: the area where the motor could operate for a long period without over-heating. In the performance curves provided below, the black-colored, lower-positioned curve is the continuous performance curve. The area contained under this curve is the continuous operation area.
- Intermittent operation area: the area over the continuous area, in which motor can run for a short period of time as in overload mode. In the performance curves provided below, the red-colored curves with input voltage marked (110 VAC, 230 VAC, 400 VAC or 460 VAC) are the peak performance curves. The areas between a specific peak curve and the continuous curve is the intermittent operation area by the corresponding input voltage marked. The time allowed to run a motor in the intermittent operation area is decided comprehensively by the operating environment, ventilation conditions and the drive capacity, etc.

### Rated voltage level AC230 V, temperature class T4

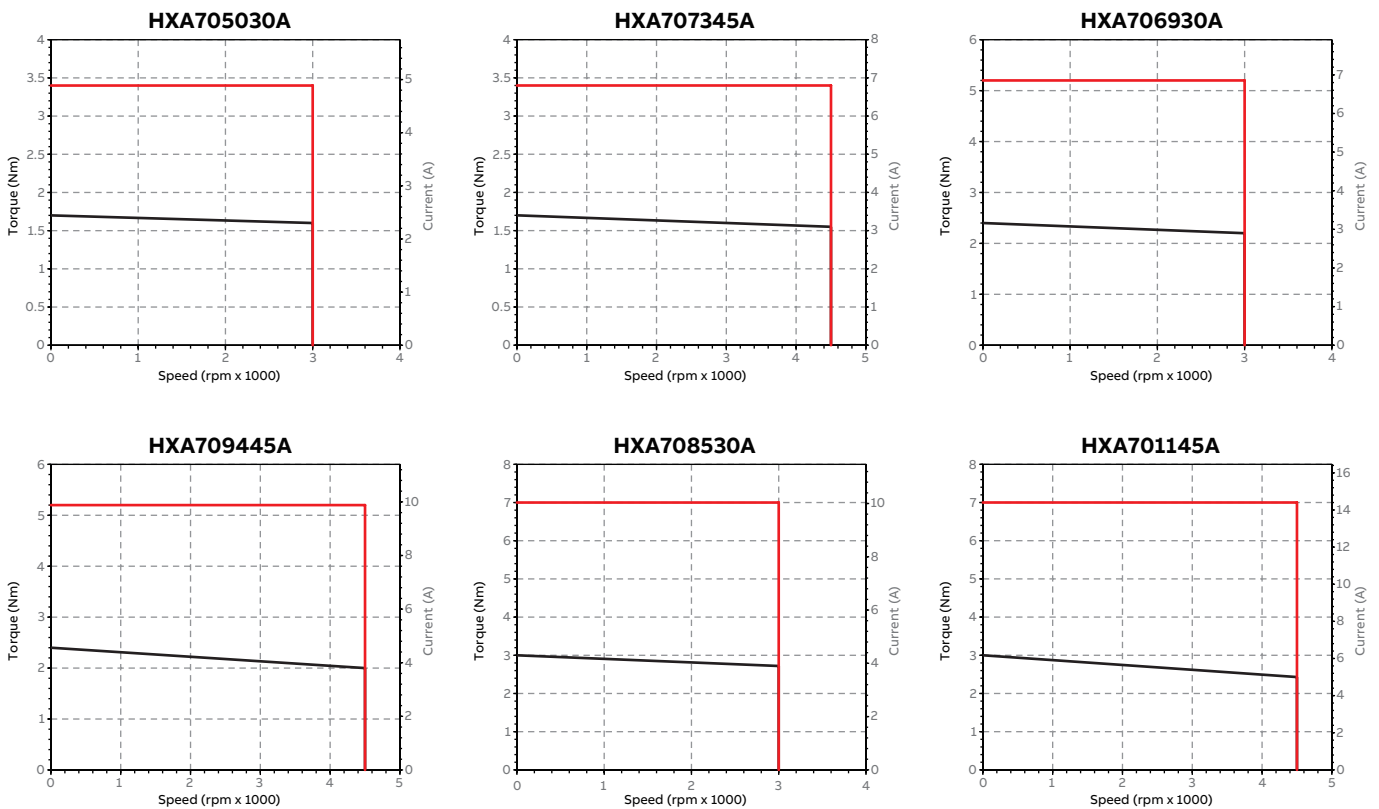

# HX explosion-proof servo motors

## Performance curves

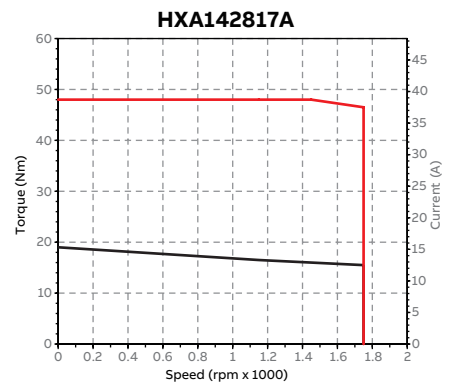
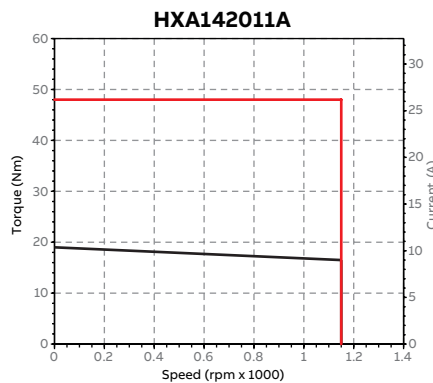
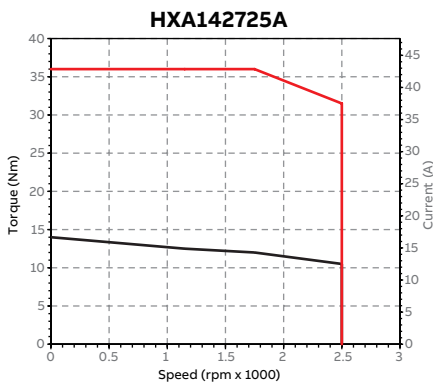
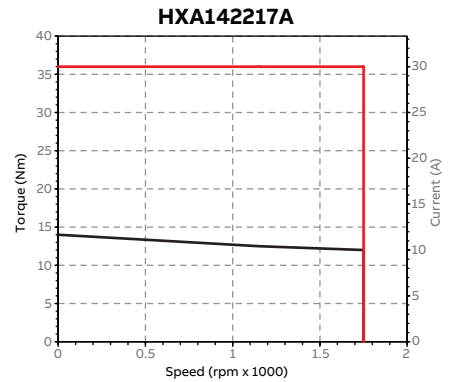
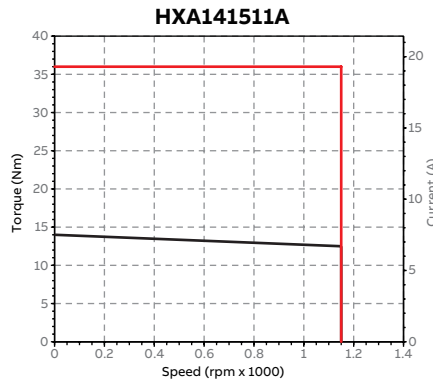
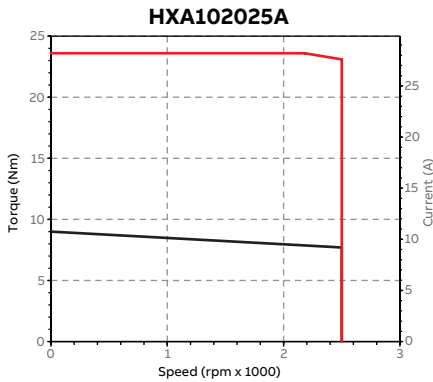
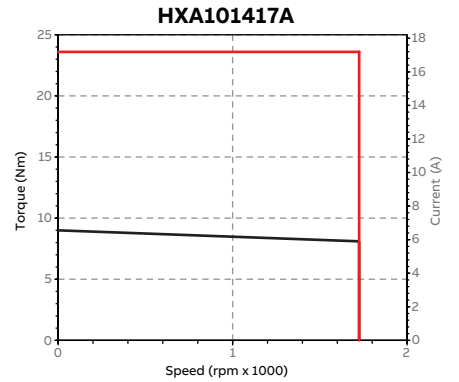
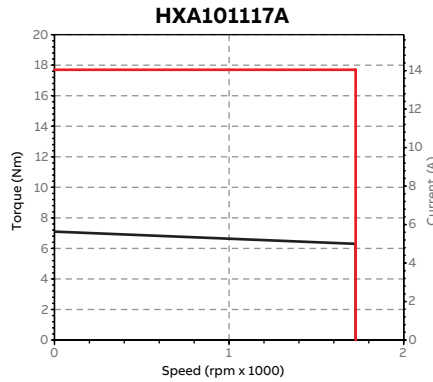
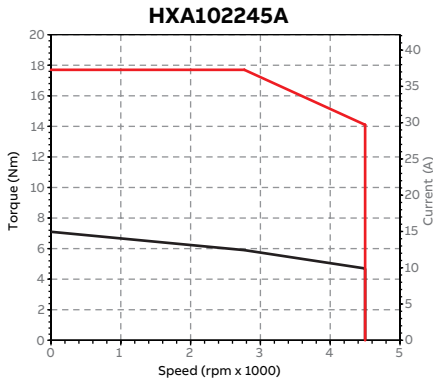
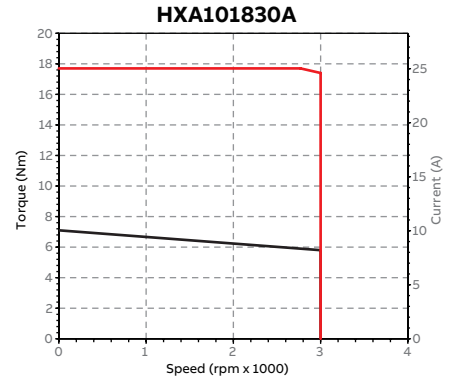
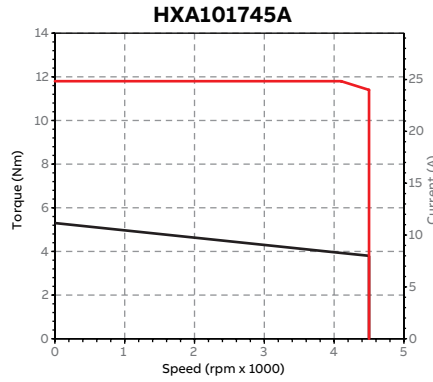
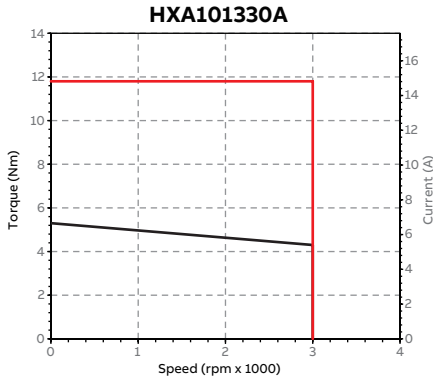

# HX explosion-proof servo motors

## Performance curves

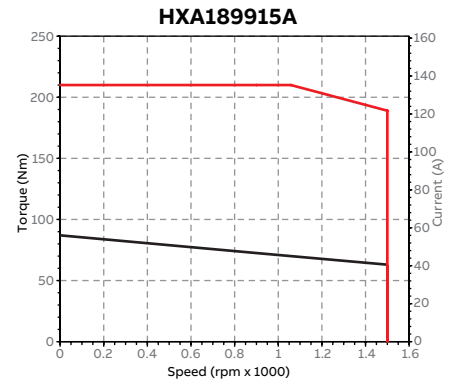
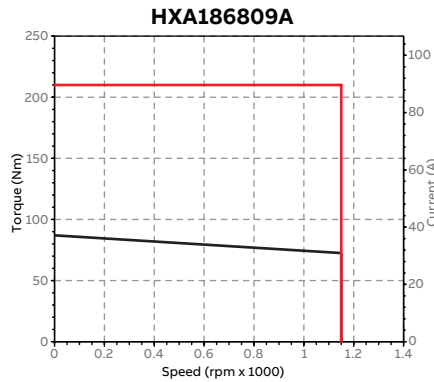
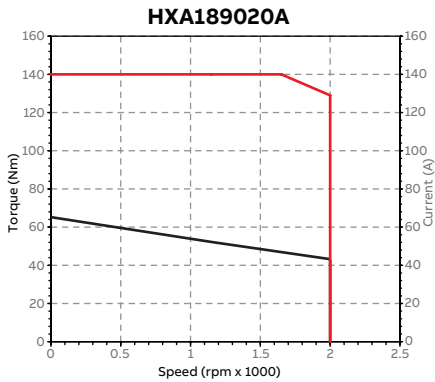
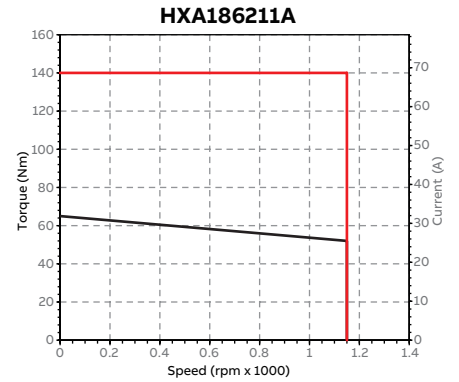
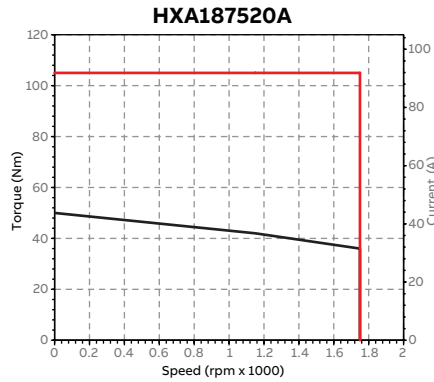
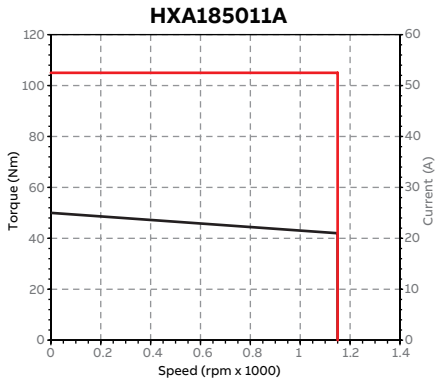
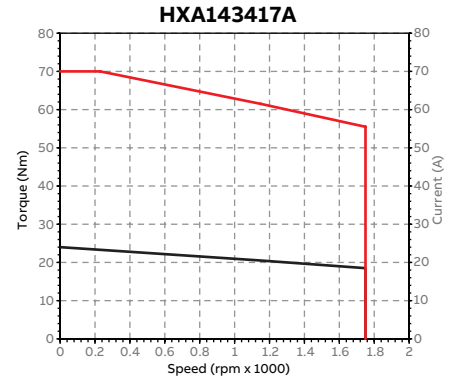
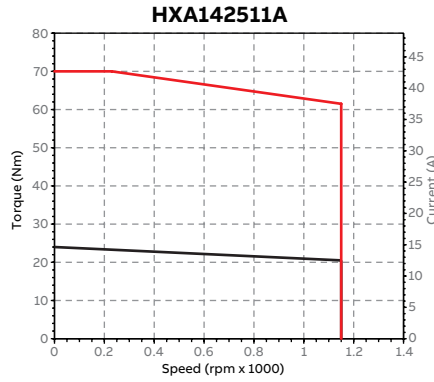
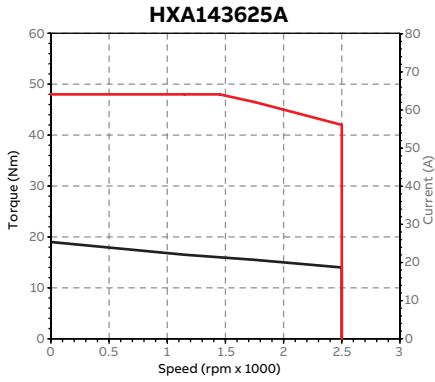

# HX explosion-proof servo motors

## Performance curves

Rated voltage level AC400 V, temperature class T4

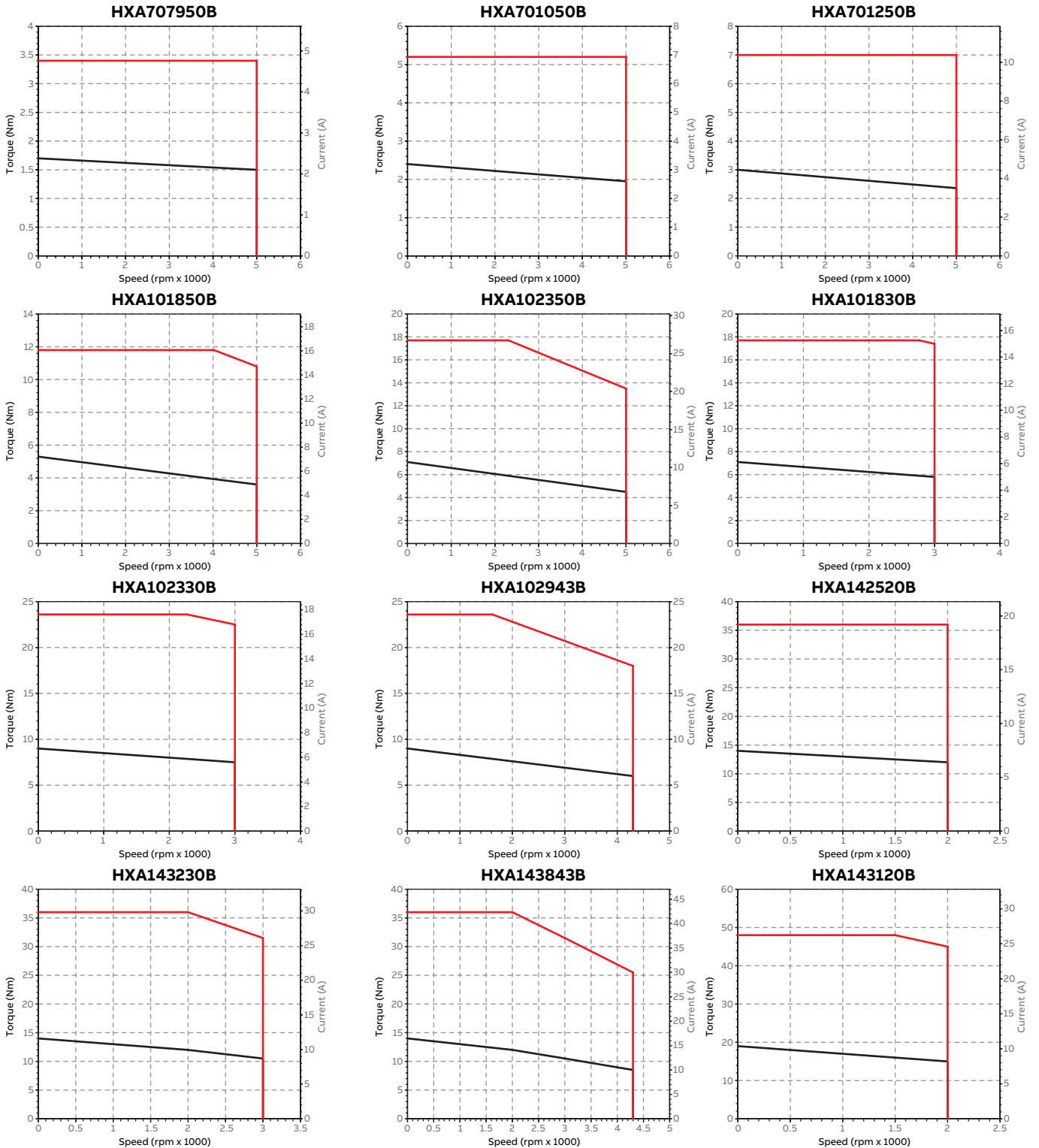

# HX explosion-proof servo motors

## Performance curves

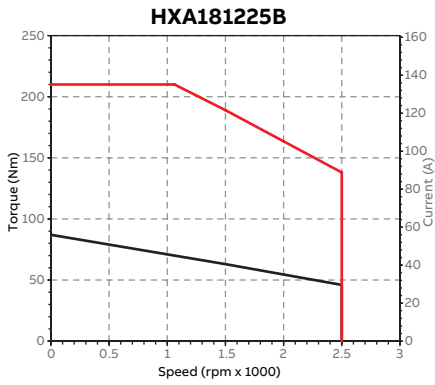
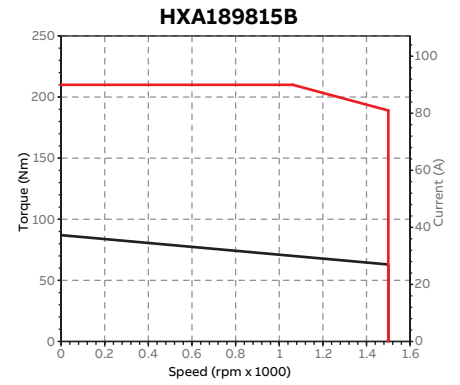
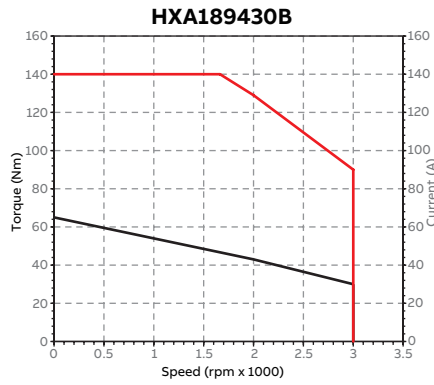
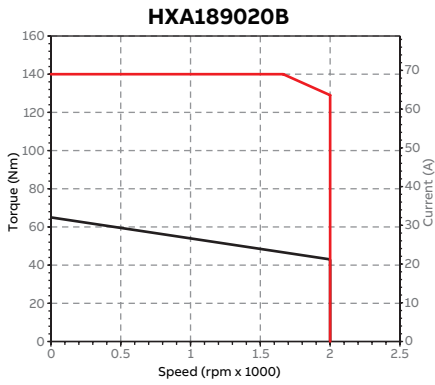
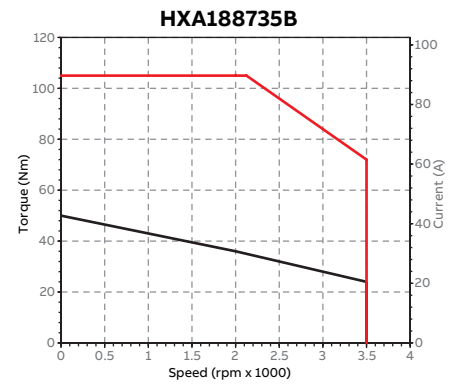
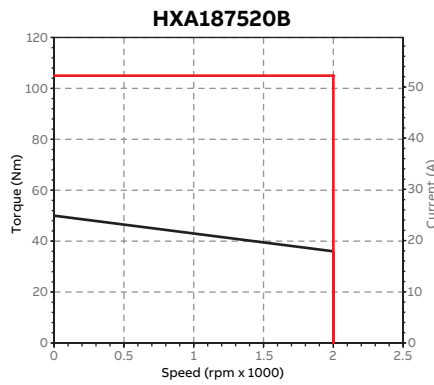
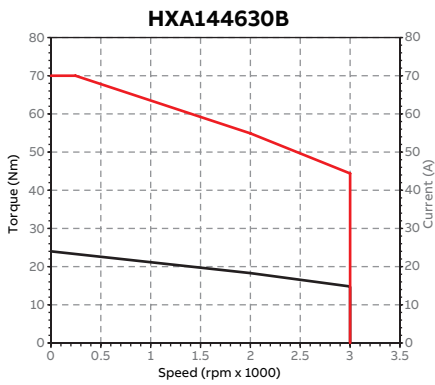
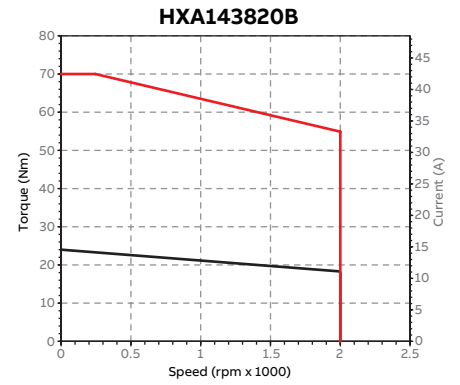
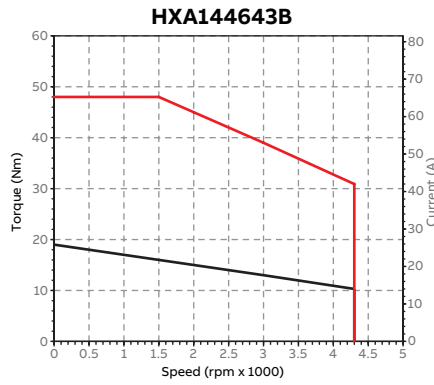
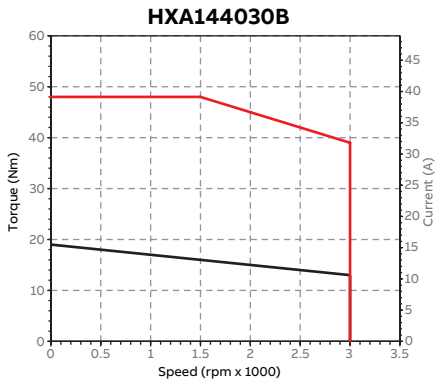

# HX explosion-proof servo motors

## Performance curves

Rated voltage level AC230 V, temperature class T5

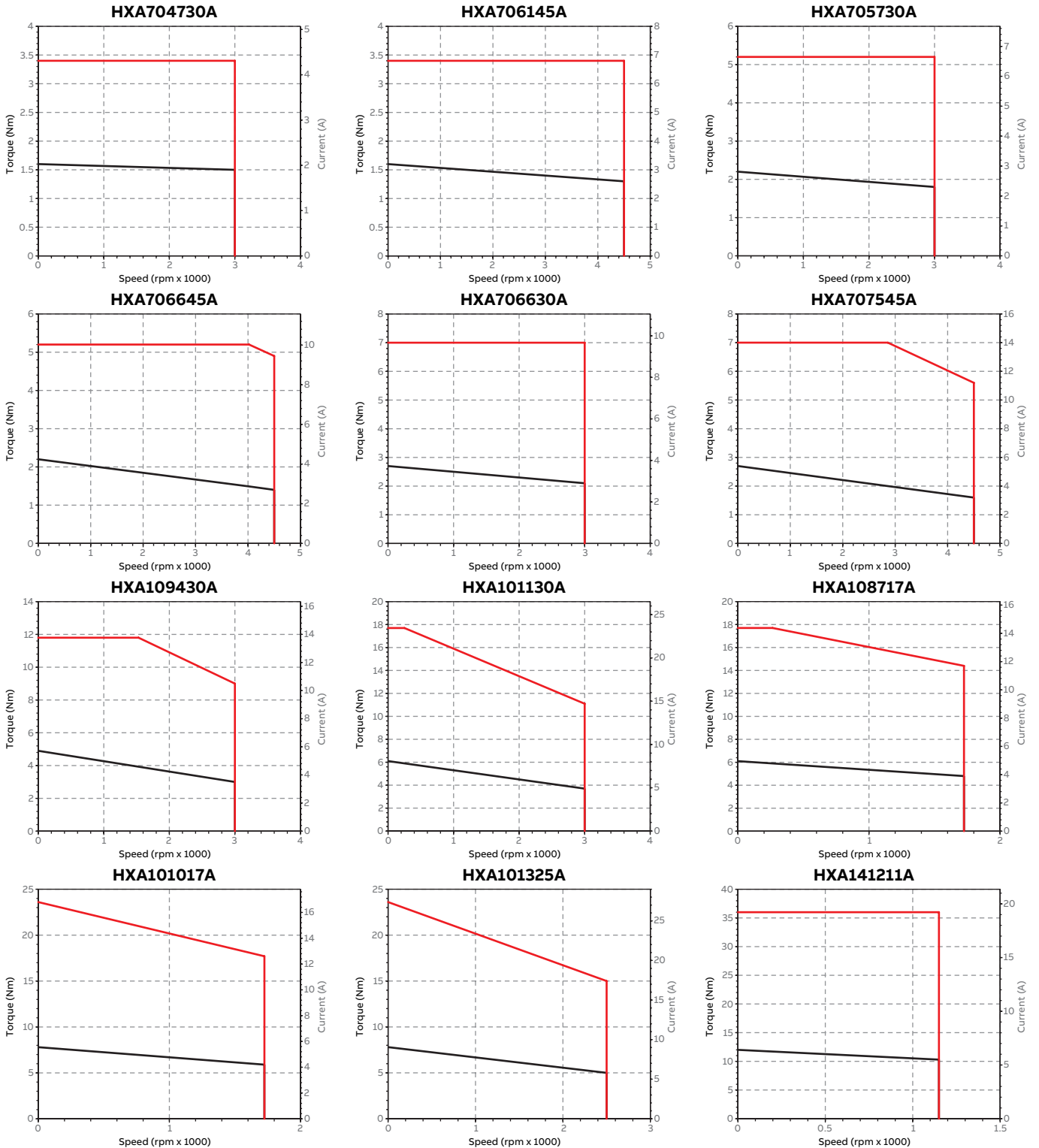

# HX explosion-proof servo motors

## Performance curves

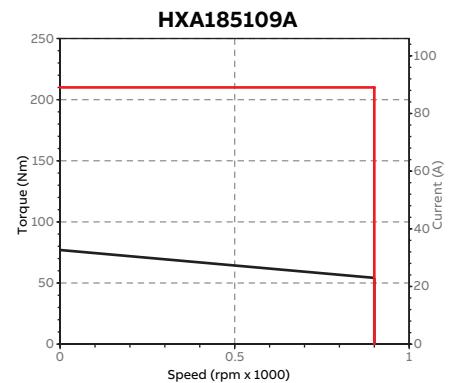
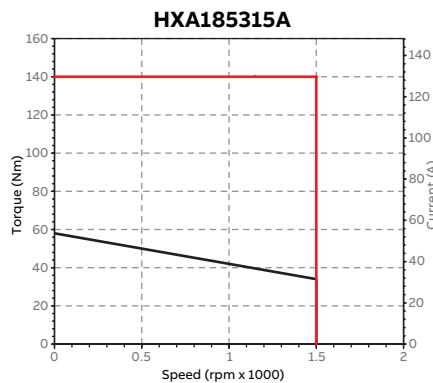
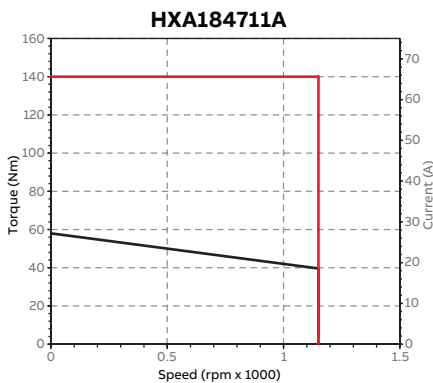
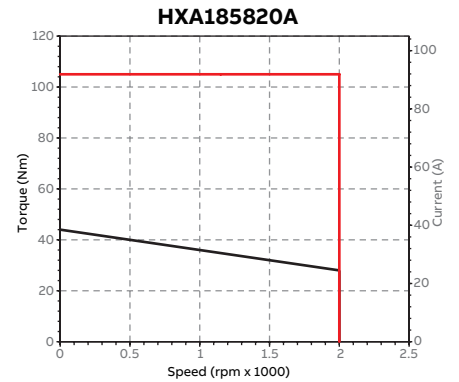
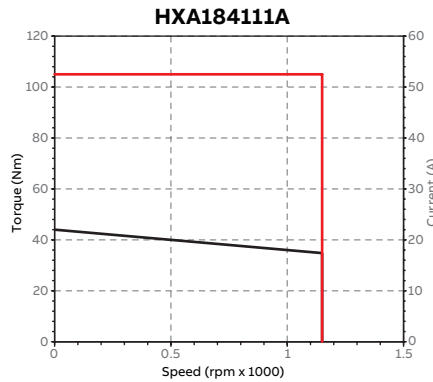
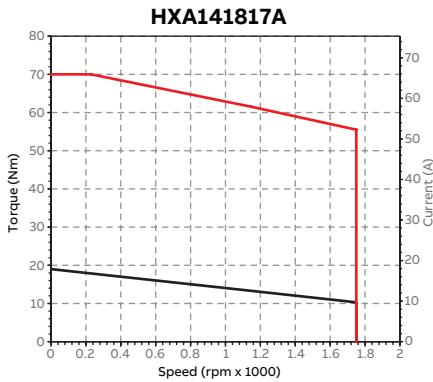
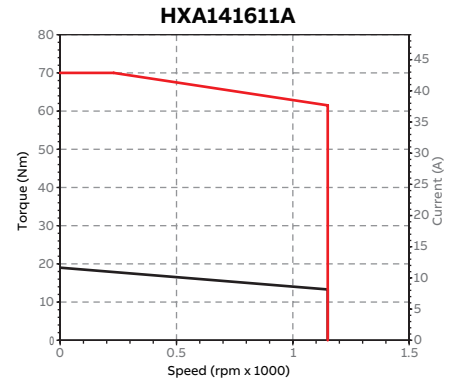
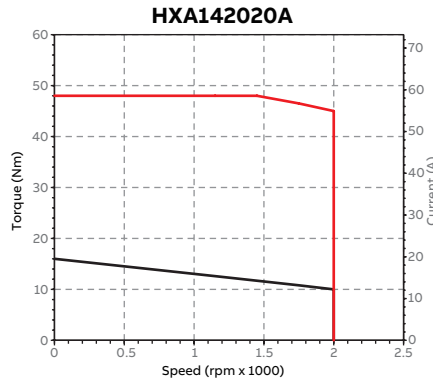
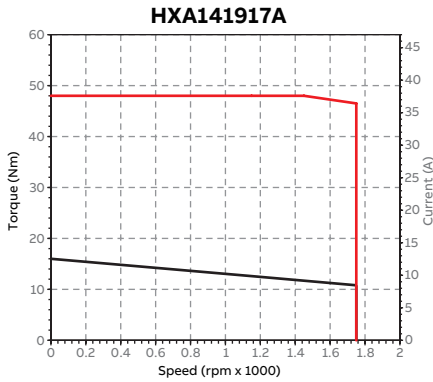
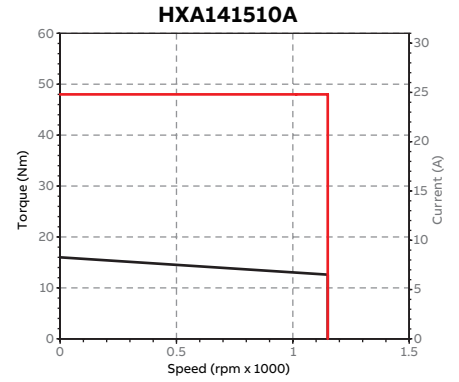
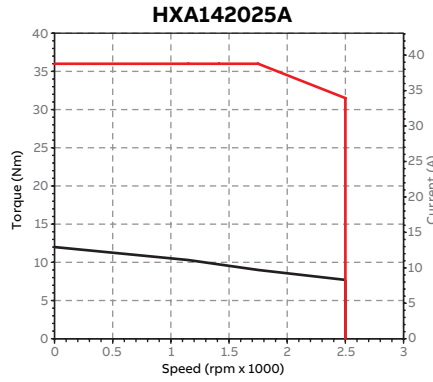
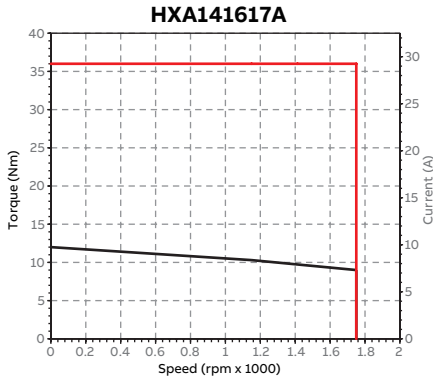

# HX explosion-proof servo motors

## Performance curves

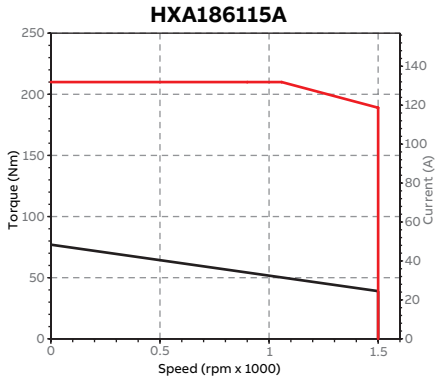

Rated voltage level AC400 V, temperature class T5

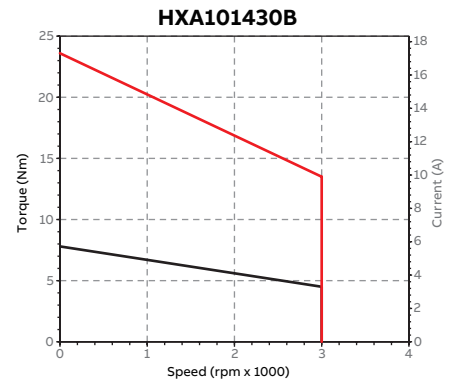
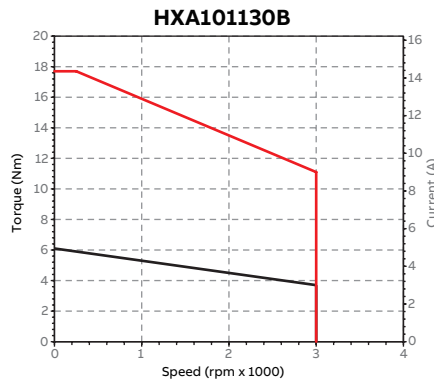
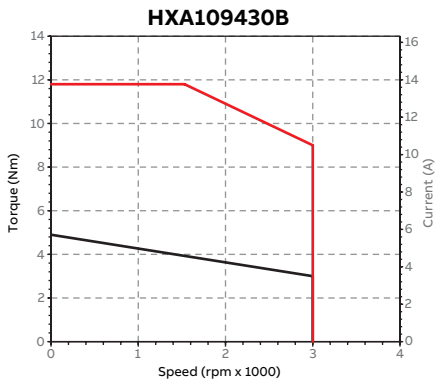
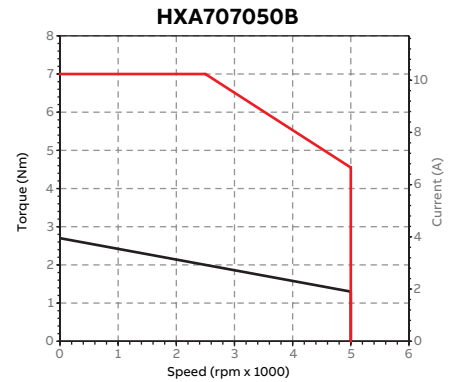
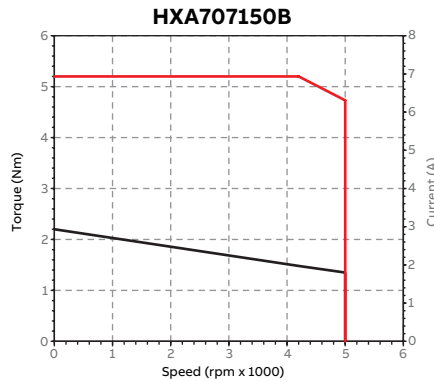
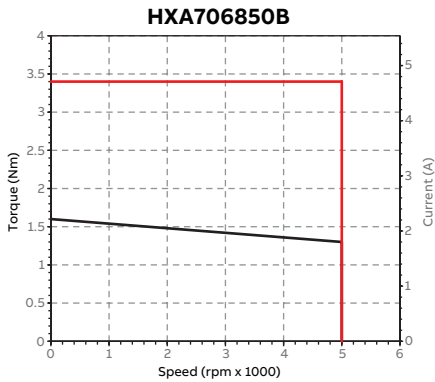

# HX explosion-proof servo motors

## Performance curves

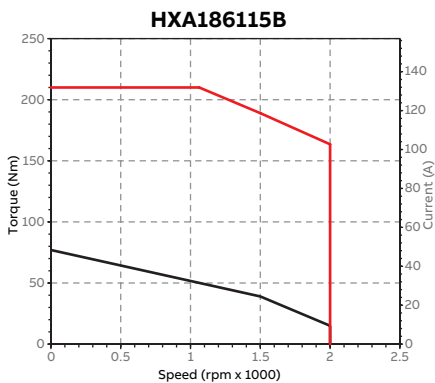
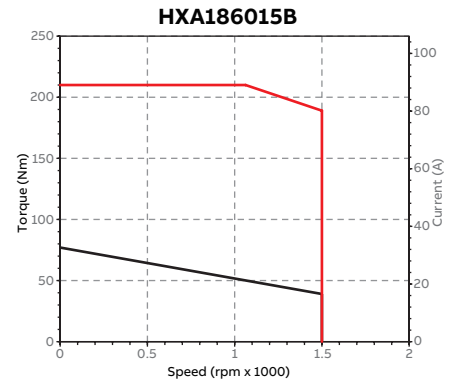
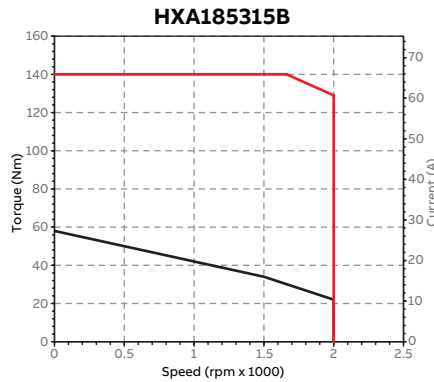
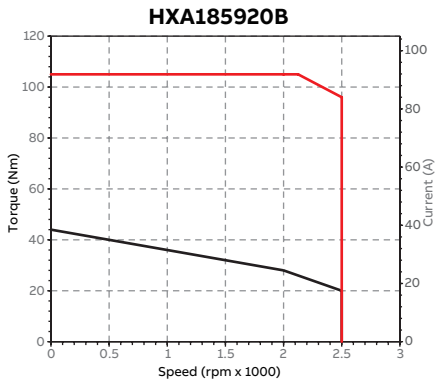
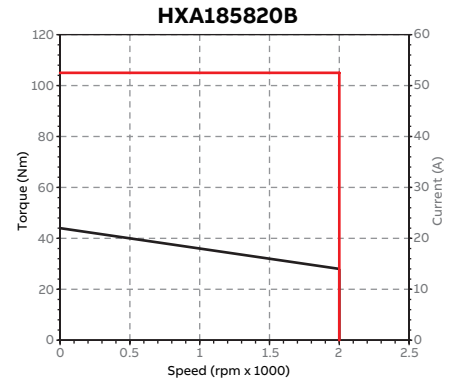
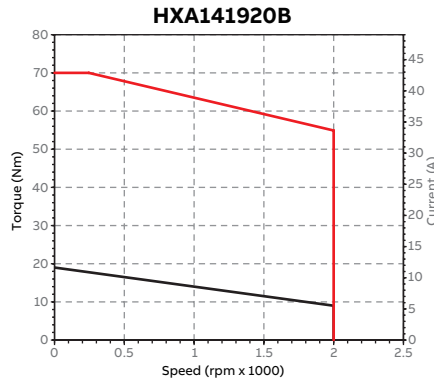
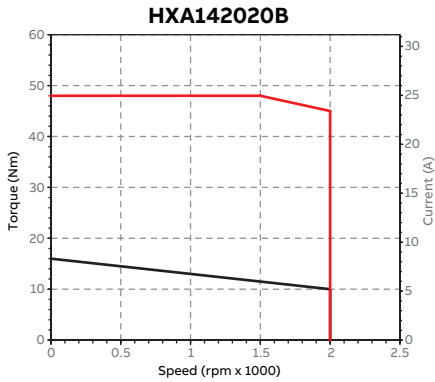
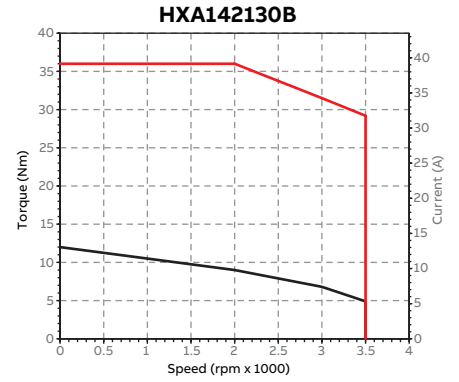
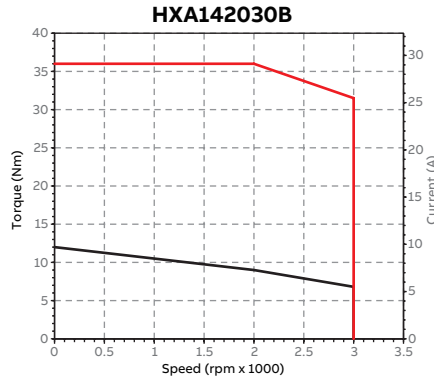
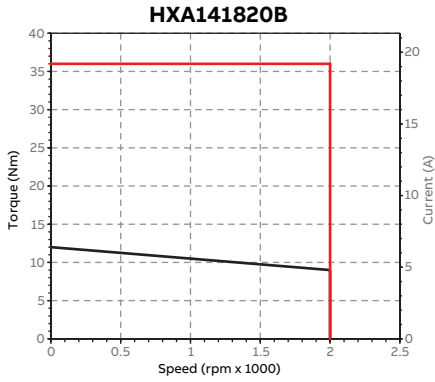



# HX explosion-proof servo motors

## Motor dimension

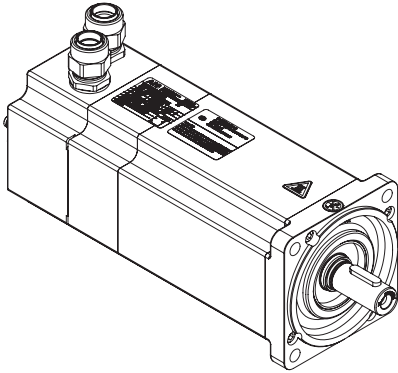

HXA10 layout

Model	Certified model	Motor size model	w/o brake LB [mm]	With brake LB [mm]
HXA101330A				
HXA101850B	HXA10L1W30	HXA10L1*	220	245
HXA109430A				
HXA109430B				
HXA101745A	HXA10L1W45			
HXA101117A				
HXA101830B	HXA10L2W17			
HXA108717A				
HXA101130B		HXA10L2*	242	267
HXA101830A				
HXA102350B	HXA10L2W30			
HXA101130A				
HXA102245A	HXA10L2W45			
HXA101417A				
HXA102330B	HXA10L3W30			
HXA101017A				
HXA101430B		HXA10L3*	264	289
HXA102025A				
HXA102943B	HXA10L3W43			
HXA101325A				

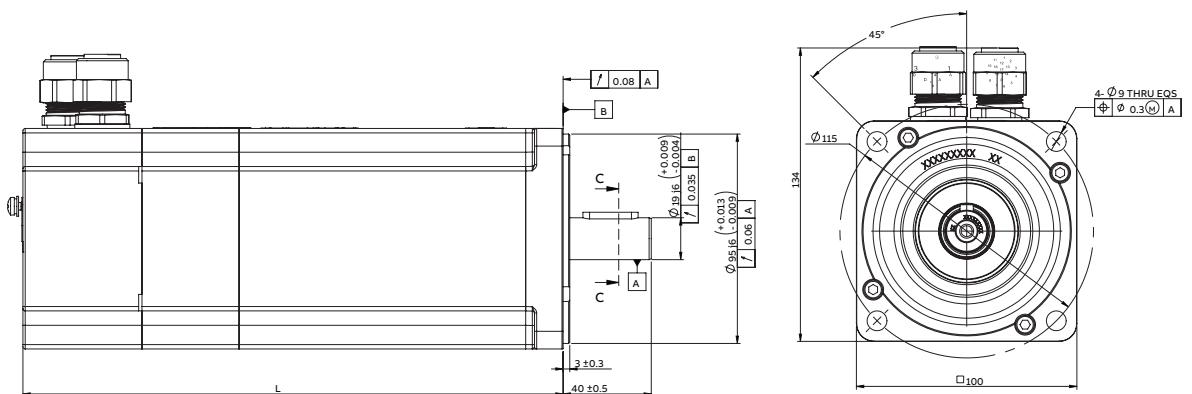

EX GLAND M16\*1.5(8-11mm)  
TIGHTENING TORQUE:10Nm

EX GLAND M20\*1.5(11-14.3mm)  
TIGHTENING TORQUE:13Nm

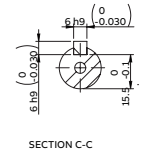
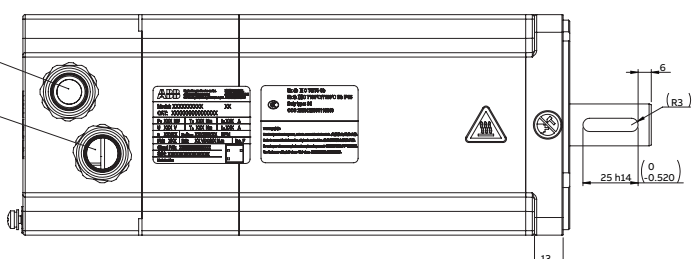

# HX explosion-proof servo motors

## Motor dimension

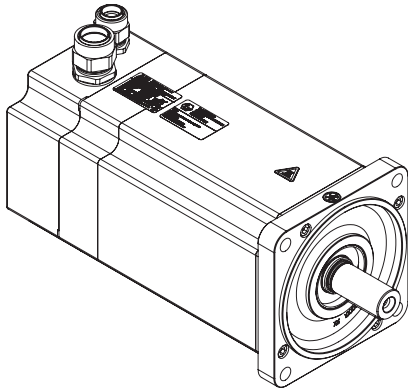

HXA14 layout

Model	Certified model	Motor size model	w/o brake LB [mm]	With brake LB [mm]
HXA141511A				
HXA142520B	HXA14L1W20			
HXA141211A				
HXA141820B				
HXA142217A				
HXA143230B	HXA14L1W30	HXA14L1*	239.5	264.5
HXA141617A				
HXA142030B				
HXA142725A				
HXA143843B	HXA14L1W43			
HXA142025A				
HXA142130B				
HXA142011A				
HXA143120B	HXA14L2W20			
HXA141510A				
HXA142020B				
HXA142817A				
HXA144030B	HXA14L2W30	HXA14L2*	257	282
HXA141917A				
HXA143625A				
HXA144643B	HXA14L2W43			
HXA142020A				
HXA142511A				
HXA143820B	HXA14L3W20			
HXA141611A				
HXA141920B		HXA14L3*	292	317
HXA143417A				
HXA144630B	HXA14L3W30			
HXA141817A				

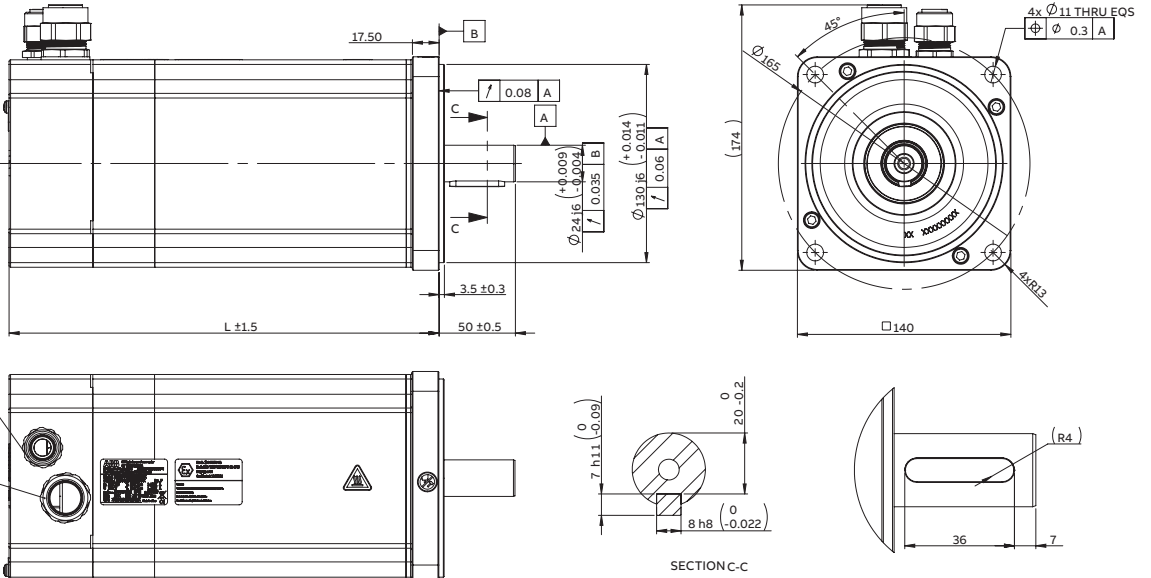

# HX explosion-proof servo motors

## Motor dimension

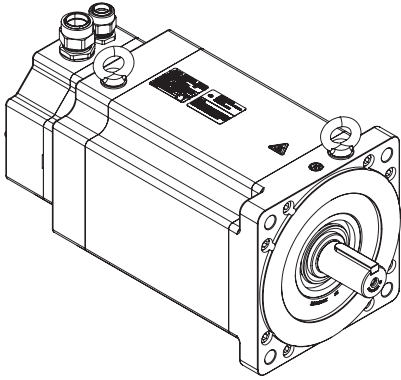

HXA18 layout

Model	Certified model	Motor size model	w/o brake LB [mm]	With brake LB [mm]
HXA185011A				
HXA187520B	HXA18L1W20			
HXA184111A				
HXA185820B		HXA18L1*	325	342
HXA187520A				
HXA188735B	HXA18L1W35			
HXA185820A				
HXA185920B				
HXA186211A				
HXA189020B	HXA18L2W20			
HXA184711A				
HXA185315B		HXA18L2*	354	371
HXA189020A				
HXA189430B	HXA18L2W30			
HXA185315A				
HXA186809A				
HXA189815B	HXA18L3W15			
HXA185109A				
HXA186015B		HXA18L3*	412	429
HXA189915A				
HXA181225B	HXA18L3W25			
HXA186115A				
HXA186115B				

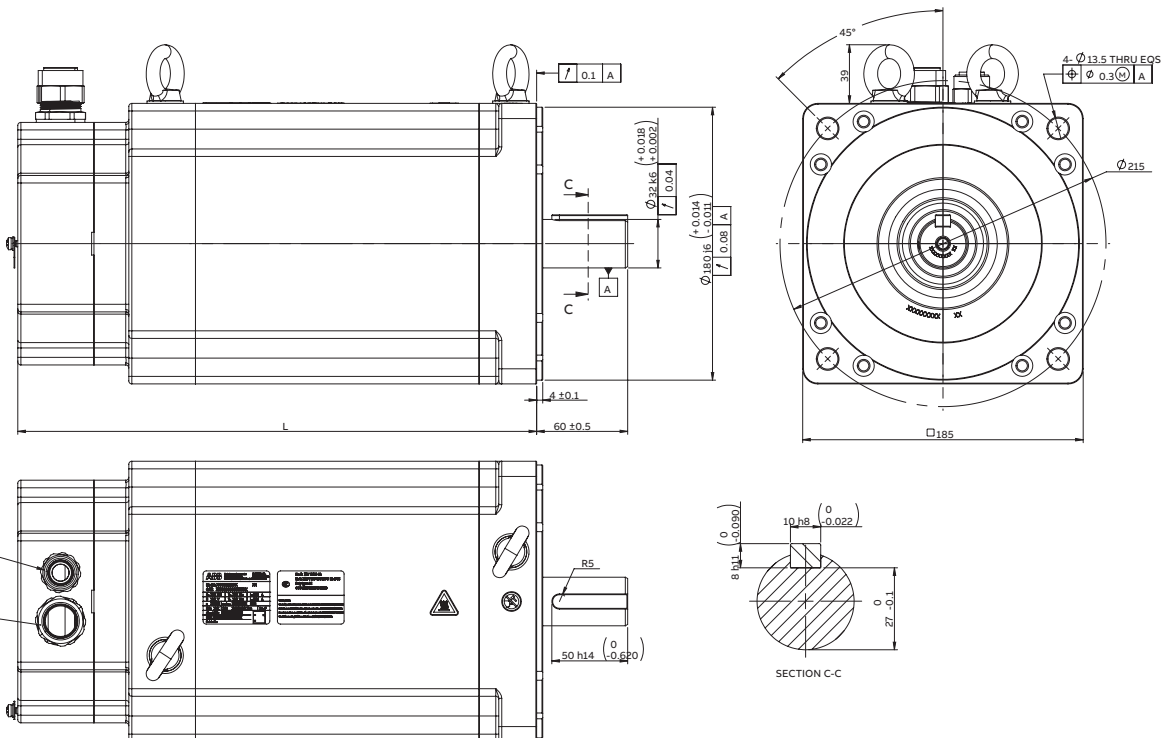

# HX explosion-proof servo motors

## Interface definition

### Power and Feedback interface – HXA70/10/14/18 \*1

HXA70/10/14		Power interface	
Pin	Definition	Pin	Definition
U	U	U	U
V	V	V	V
W	W	W	W
PE	Ground	PE	Ground
TH+	Thermistor	TH+	Thermistor
TH-	Thermistor	TH-	Thermistor
BR+	Brake (optional)	BR+	Brake (optional)
BR-	Brake (optional)	BR-	Brake (optional)
HXA18		Feedback interface	
Pin	Resolver	Pin	Hiperface
1	R1 (REF+)	Us	Us
2	R2 (REF-)	GND	GND
3	S1 (COS+)	Data+	Data+
4	S3 (COS-)	Data-	Data-
5	S4 (SIN-)	SIN+	SIN+
6	S2 (SIN+)	SIN-	SIN-
7	-	COS+	COS+
8	-	COS-	COS-

Notes: \*1, The cable and interface connection with an Allen key opening the rear cover of the motor.

# HX explosion-proof servo motors

## Nameplate and identifiers

HX series motor is accompanied with nameplate, explosion-proof marking, hot warning, no strike warning

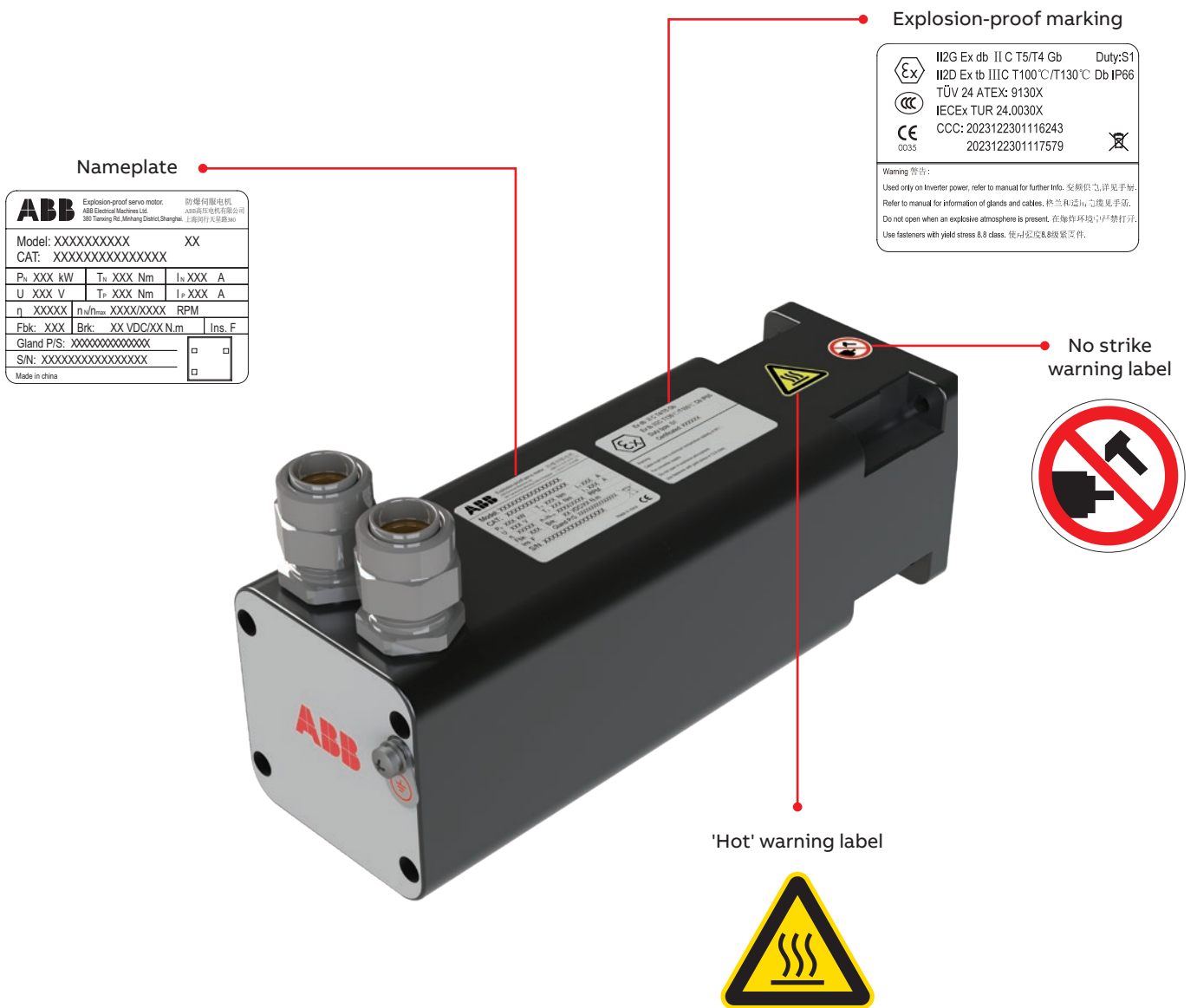

# HY explosion-proof servo motors

## Product highlights

The HY series is ABB high-performance explosion-proof servo motor product series that is based on the same advanced platform and launched after the HDS AC permanent magnet servo motor family. With the safety-enhanced type and enclosure-equipped type explosion protection design, HY series is suitable for explosion-proof applications that require explosion protection certification and can ensure the safe operation of the product in gas and dust explosion-proof environments. The explosion-proof performance complies with standards, with CCC explosion-proof markings as Ex ec IIC T4 Gc and Ex tb IIIC T130°C Db IP65, and ATEX markings as II 3 G Ex ec IIC T4 Gc and II 3 D Ex tc IIIC T130°C Dc IP65.



— High torque density and power density: reduced volume and weight.



— In accordance with the energy efficiency standard GB 30253, all models are of energy efficiency level 1.



— Low cogging torque and torque ripple: excellent performance at low speed and system control. Fast dynamic response, accurate rotor balance.



— Outstanding overload performance: 3 times peak torque, 4 times mechanical overload capacity.





— Brake optional. Resolvers are standard accessories. Cable kits are available, or you can purchase standard cable connectors.



— Epoxy resin potting technology on complete stator: compact size and better heat dissipation



— High-precision machining technology, more precise engagement between the flange and rotating shaft to ensure less noise and vibration.



— Explosion-proof double certification system, ATEX and CCC explosion-proof certification.

# HY explosion-proof servo motors

## Data sheet

Frame size		HYA65	HYA10		HYA13		HYA18		
Model		5030A	1030A	1730A	1620B	2820B	5020B	6520B	8020B
<b>Rated power</b>	<b>kW</b>	<b>0.5</b>	<b>1.0</b>	<b>1.7</b>	<b>1.6</b>	<b>2.8</b>	<b>5.0</b>	<b>6.5</b>	<b>8.0</b>
<b>General</b>									
Input voltage	VAC	230	230	230	400	400	400	400	400
Rated torque	N·m	1.6	3.2	5.3	7.5	13.4	24	31	38.5
Peak torque	N·m	4.5	9.6	16.5	22.5	45	75	105	135
Continuous stall torque	N·m	1.8	4	7	7.8	17	29	41	50
Rated current	A <sub>rms</sub>	4.3	5.6	9.1	7	10.8	15.3	20.2	24.2
Peak current	A <sub>rms</sub>	14.7	20	36.2	27.8	42.4	48.8	68.5	95
Continuous stall current	A <sub>rms</sub>	4.4	6.7	11.4	7.1	12.7	18	25.7	30
Rated speed	rpm	3000	3000	3000	2000	2000	2000	2000	2000
Maximum speed <sup>1)</sup>	rpm	5000	4000	4000	4000	4000	3500	3500	3500
Maximum continuous power	kW	0.54	1.0	1.7	1.9	3.2	5.1	7.1	8.5
Speed at maximum continuous power	rpm	4000	3000	3000	3000	3000	2500	2500	2500
<b>Electrical</b>									
Torque constant <sup>2)</sup>	N·m/A <sub>rms</sub>	0.44	0.68	0.69	1.22	1.4	1.75	1.74	1.75
Voltage constant	V <sub>rms</sub> /krpm	26.4	41.3	41.8	73.5	84.7	105.9	105.1	105.9
Line resistance	ohms	1.45	1.1	0.65	1.6	0.58	0.36	0.19	0.13
Line inductance	mH	6.4	7.54	5.15	12.3	6.13	5.9	3.9	2.9
Electrical time constant	ms	4.4	6.9	7.9	7.7	10.5	16.5	20.2	22.2
<b>Mechanical</b>									
Rotor inertia with brake	kg·cm <sup>2</sup>	0.41	1.44	1.98	5.06	10.74	51.7	70.6	89.2
Rotor inertia w/o brake	kg·cm <sup>2</sup>	0.38	1.31	1.85	4.06	9.74	44.6	63.5	82.1
Mechanical time constant	ms	0.3	0.3	0.2	0.4	0.3	0.5	0.4	0.3
Number of poles	p	10	10	10	10	10	10	10	10
Motor weight with brake	kg	2.88	5.47	6.27	8.6	12.2	23.4	28.1	32.6
Motor weight w/o brake	kg	2.55	4.71	5.51	6.65	10.25	19.7	24.4	28.9
Thermal time constant	min	17	28	23	49	54	45	58	56
Maximum radial load (@LF <sup>3)</sup> )	N	420 (@30 mm)	550 (@30 mm)	700 (@40 mm)	600 (@40 mm)	700 (@40 mm)	1900 (@65 mm)		
Maximum axial load <sup>3)</sup>	N	150	150	270	350	600			
<b>Ambient</b>									
Insulation class	-	F	F	F	F	F	F	F	F
Operating temperature	°C	-20...40	-20...40	-20...40	-20...40	-20...40	-20...40	-20...40	-20...40
Operating humidity	%	5~95 (no dew)	5~95 (no dew)	5~95 (no dew)	5~95 (no dew)	5~95 (no dew)	5~95 (no dew)	5~95 (no dew)	5~95 (no dew)
Storage temperature	°C	-40...50	-40...50	-40...50	-40...50	-40...50	-40...50	-40...50	-40...50
<b>Brake parameters</b>									
Voltage	VDC ± 10%	24	24	24	24	24	24	24	24
Current	A	0.47	0.58	0.58	0.87	0.87	1.06	1.06	1.06
Power	W	11.4	14	14	20.8	20.8	25.3	25.3	25.3
Static torque	N·m (min)	2.0	4.5	4.5	18	18	55	55	55
Pull-in time	ms (max)	40	80	80	145	145	60	60	60
Release time	ms (max)	60	20	20	40	40	200	200	200

Notes: 1) The max speed in applications shall be co-decided by the input voltage and the output frequency range and the output frequency range of the drive, feedback encoder type, etc. For higher speed applications, please contact ABB.

2) The torque constant decreases in a non-linear manner as the torque increases, the values are considered valid until approximately 2 times cont. stall torque.

3) The allowable load of the shaft is shown in the figure below. In mechanical design, radial and axial loads in servo motor operation should be prevented from exceeding the values in the table. Values are based on an estimate of the combined load capacity of bearing at rated speed. For detailed bearing load capacity data, please contact ABB.

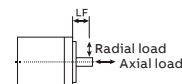

# HY explosion-proof servo motors

## Performance curves

### Motor performance curves and operation areas

The operation area of HDS servo motors is defined by performance curves in a 2-dimensional plane with coordinates of output torque and rotation speed. The performance curves of each type divide the operation area into continuous operation area and intermittent operation area.

- Continuous operation area: the area where the motor could operate for a long period without over-heating. In the performance curves provided below, the black-colored, lower-positioned curve is the continuous performance curve. The area contained under this curve is the continuous operation area.
- Intermittent operation area: the area over the continuous area, in which motor can run for a short period of time as in overload mode. In the performance curves provided below, the red-colored curves with input voltage marked (110 VAC, 230 VAC, 400 VAC or 460 VAC) are the peak performance curves. The areas between a specific peak curve and the continuous curve is the intermittent operation area by the corresponding input voltage marked. The time allowed to run a motor in the intermittent operation area is decided comprehensively by the operating environment, ventilation conditions and the drive capacity, etc.

### Rated voltage level AC230 V, temperature class T4

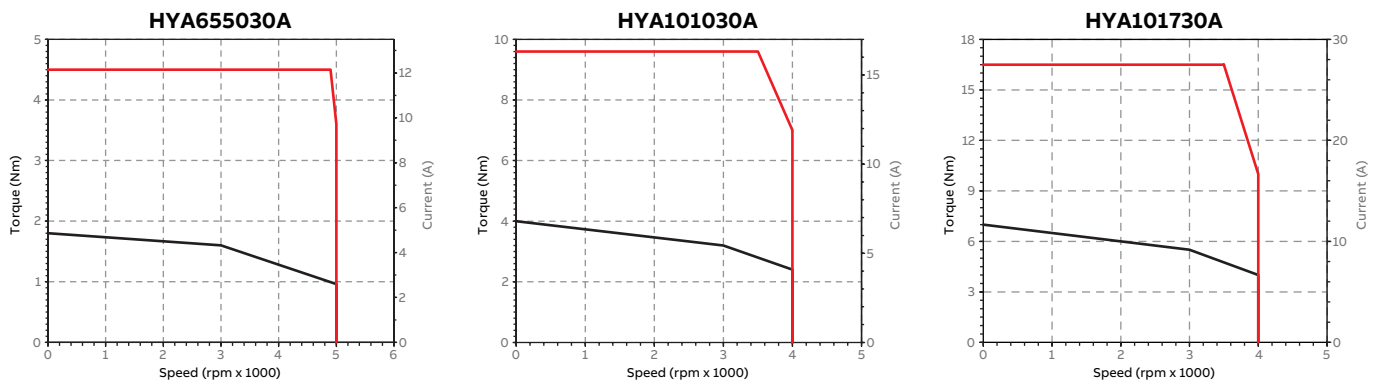

# HY explosion-proof servo motors

## Performance curves

Rated voltage level AC400 V, temperature class T4

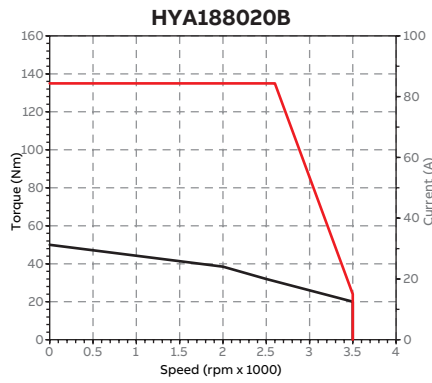
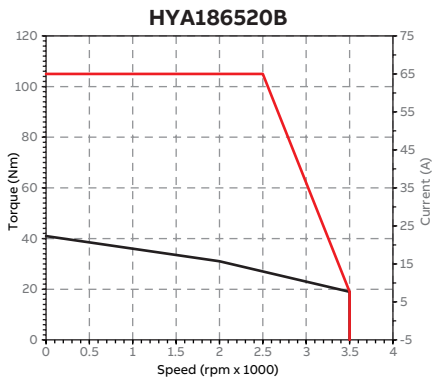
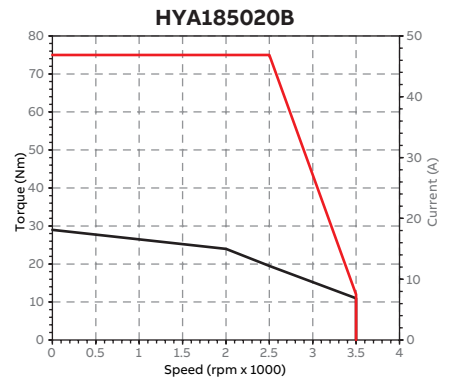
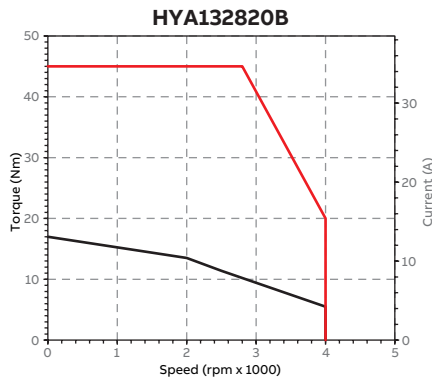
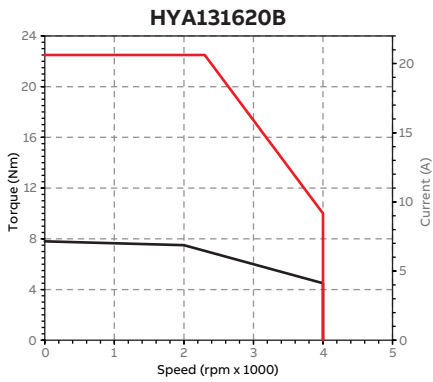

# HY explosion-proof servo motors

## Motor dimension

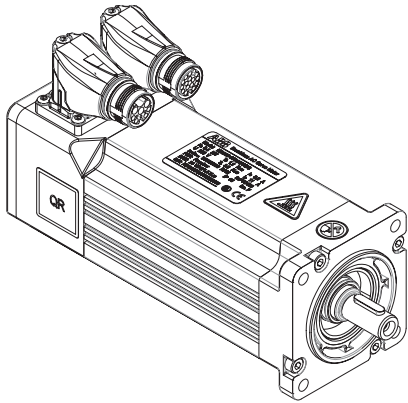

HYA65 layout

Model	LB [mm]
HYA655030A	183.5

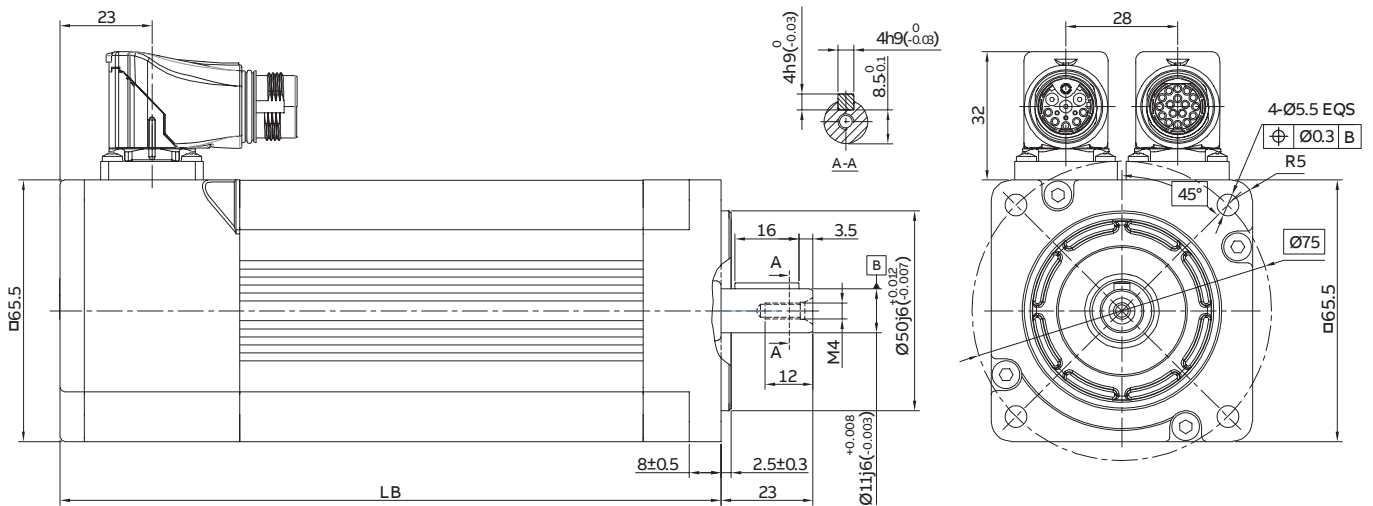

# HY explosion-proof servo motors

## Motor dimension

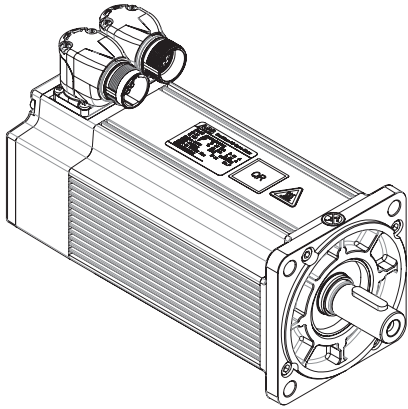

### HYA10 layout

Model	LB [mm]
HYA101030A	213.5
HYA101730A	237.5

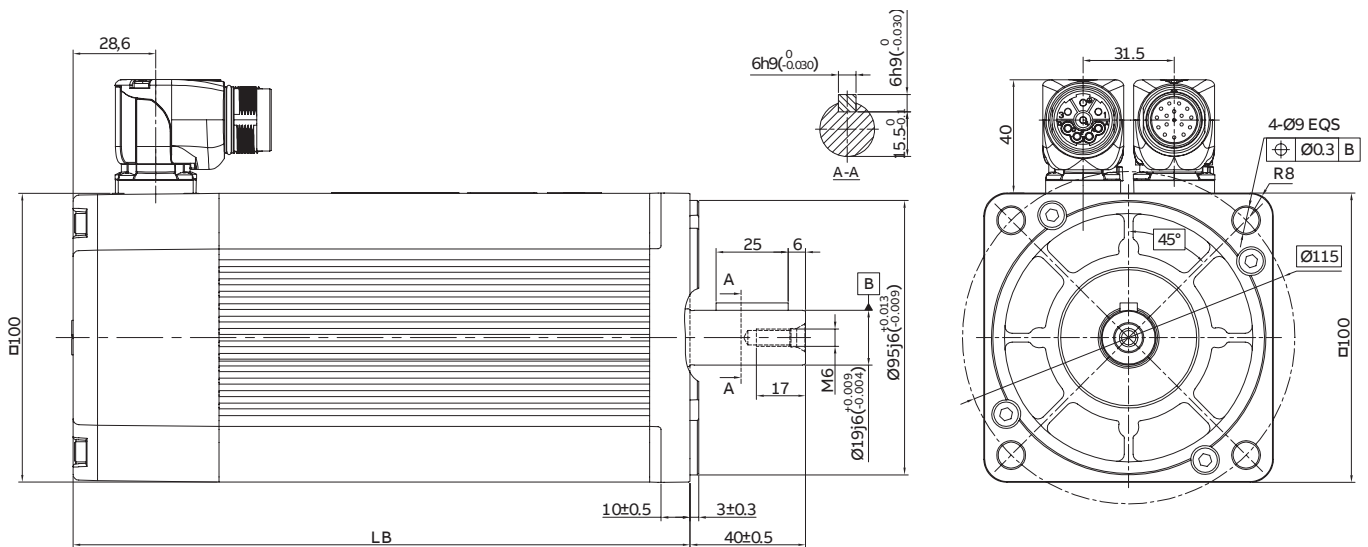





# HY explosion-proof servo motors

## Interface definition

### Power interface - HYA65/10/13/18

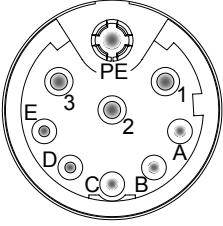
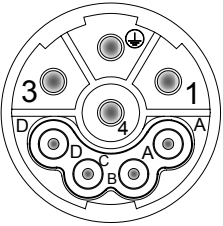
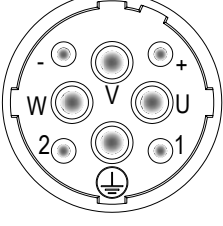
Dual cable																					
<p><b>M17 power connector</b></p> 	<p><b>HYA65</b></p> <table border="1"> <thead> <tr> <th>Pin</th> <th>Definition</th> </tr> </thead> <tbody> <tr><td>1</td><td>U</td></tr> <tr><td>2</td><td>V</td></tr> <tr><td>3</td><td>W</td></tr> <tr><td>PE</td><td>Ground</td></tr> <tr><td>A</td><td>Thermistor</td></tr> <tr><td>B</td><td>Thermistor</td></tr> <tr><td>C</td><td>Brake (optional)</td></tr> <tr><td>D</td><td>Brake (optional)</td></tr> <tr><td>E</td><td>-</td></tr> </tbody> </table>	Pin	Definition	1	U	2	V	3	W	PE	Ground	A	Thermistor	B	Thermistor	C	Brake (optional)	D	Brake (optional)	E	-
Pin	Definition																				
1	U																				
2	V																				
3	W																				
PE	Ground																				
A	Thermistor																				
B	Thermistor																				
C	Brake (optional)																				
D	Brake (optional)																				
E	-																				
<p><b>M23 power connector</b></p> 	<p><b>HYA10/13</b></p> <table border="1"> <thead> <tr> <th>Pin</th> <th>Definition</th> </tr> </thead> <tbody> <tr><td>1</td><td>U</td></tr> <tr><td>2</td><td>Ground</td></tr> <tr><td>3</td><td>W</td></tr> <tr><td>4</td><td>V</td></tr> <tr><td>A</td><td>Thermistor</td></tr> <tr><td>B</td><td>Thermistor</td></tr> <tr><td>C</td><td>Brake (optional)</td></tr> <tr><td>D</td><td>Brake (optional)</td></tr> </tbody> </table>	Pin	Definition	1	U	2	Ground	3	W	4	V	A	Thermistor	B	Thermistor	C	Brake (optional)	D	Brake (optional)		
Pin	Definition																				
1	U																				
2	Ground																				
3	W																				
4	V																				
A	Thermistor																				
B	Thermistor																				
C	Brake (optional)																				
D	Brake (optional)																				
<p><b>M40 power connector</b></p> 	<p><b>HYA18</b></p> <table border="1"> <thead> <tr> <th>Pin</th> <th>Definition</th> </tr> </thead> <tbody> <tr><td>U</td><td>U</td></tr> <tr><td>V</td><td>V</td></tr> <tr><td>W</td><td>W</td></tr> <tr><td>PE</td><td>Ground</td></tr> <tr><td>1</td><td>Thermistor</td></tr> <tr><td>2</td><td>Thermistor</td></tr> <tr><td>+</td><td>Brake (optional)</td></tr> <tr><td>-</td><td>Brake (optional)</td></tr> </tbody> </table>	Pin	Definition	U	U	V	V	W	W	PE	Ground	1	Thermistor	2	Thermistor	+	Brake (optional)	-	Brake (optional)		
Pin	Definition																				
U	U																				
V	V																				
W	W																				
PE	Ground																				
1	Thermistor																				
2	Thermistor																				
+	Brake (optional)																				
-	Brake (optional)																				

### Feedback interface - HYA65/10/13/18

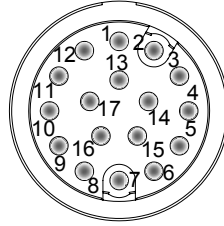
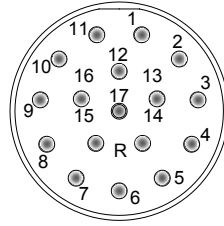
Resolver																	
<p><b>M17 signal connectors</b></p> 	<p><b>HYA65</b></p> <table border="1"> <thead> <tr> <th>Pin</th> <th>Definition</th> </tr> </thead> <tbody> <tr><td>1</td><td>R1 (REF+)</td></tr> <tr><td>2</td><td>R2 (REF-)</td></tr> <tr><td>3</td><td>S1 (COS+)</td></tr> <tr><td>4</td><td>S3 (COS-)</td></tr> <tr><td>5</td><td>S4 (SIN-)</td></tr> <tr><td>6</td><td>S2 (SIN+)</td></tr> <tr><td>7~17</td><td>-</td></tr> </tbody> </table>	Pin	Definition	1	R1 (REF+)	2	R2 (REF-)	3	S1 (COS+)	4	S3 (COS-)	5	S4 (SIN-)	6	S2 (SIN+)	7~17	-
Pin	Definition																
1	R1 (REF+)																
2	R2 (REF-)																
3	S1 (COS+)																
4	S3 (COS-)																
5	S4 (SIN-)																
6	S2 (SIN+)																
7~17	-																
<p><b>M23 signal connectors</b></p> 	<p><b>HYA10/13/18</b></p> <table border="1"> <thead> <tr> <th>Pin</th> <th>Definition</th> </tr> </thead> <tbody> <tr><td>1</td><td>R1 (REF+)</td></tr> <tr><td>2</td><td>R2 (REF-)</td></tr> <tr><td>3</td><td>S1 (COS+)</td></tr> <tr><td>4</td><td>S3 (COS-)</td></tr> <tr><td>5</td><td>S4 (SIN-)</td></tr> <tr><td>6</td><td>S2 (SIN+)</td></tr> <tr><td>7~17</td><td>-</td></tr> </tbody> </table>	Pin	Definition	1	R1 (REF+)	2	R2 (REF-)	3	S1 (COS+)	4	S3 (COS-)	5	S4 (SIN-)	6	S2 (SIN+)	7~17	-
Pin	Definition																
1	R1 (REF+)																
2	R2 (REF-)																
3	S1 (COS+)																
4	S3 (COS-)																
5	S4 (SIN-)																
6	S2 (SIN+)																
7~17	-																

# HY explosion-proof servo motors

## Nameplate and identifiers

HY series motor is accompanied with nameplate, explosion-proof marking, QR code, hot warning, no strike warning and grounding markings.

Besides the parameters on the nameplate, details of the motor could be learnt by scanning QR code.

'Hot' warning label

No strike warning label

QR code

Nameplate

<b>ABB</b> Explosion-proof servo motor. 防爆伺服电机 ABB Electric (Shanghai) Ltd. 上海阿波罗电气有限公司 365 Tianyuan Rd, Minhang District, Shanghai. 上海闵行区天苑路365号		
Model: XXXXXXXXXXXXXXXXXXXX CAT: XXXXXXXXXXXXXXXXXXXX		
P <sub>n</sub> XXX kW	T <sub>n</sub> XXX Nm	I <sub>n</sub> XXX A
U XXX V	T <sub>p</sub> XXX Nm	I <sub>p</sub> XXX A
η XXXXX	n/n <sub>base</sub> XXXX/XXXX	RPM
Fbc: XXX	Brk: XX VDC/XX N.m	
Ins. F	Gland P/S: XXXXXXXXXXXXXXXXXXXX	
S/N: XXXXXXXXXXXXXXXXXXXX		
		Made in china

Grounding label

Explosion-proof mark

Ex ec IIC T4 Gc 	II 3G Ex ec IIC T4 Gc II 3D Ex to IIC T130°C Dc
Ex tb IIIc T130°C Db CCC: 2022122301115791	TUV 21 ATEX 8642 X
DUTY: S1	TPS 21 ATEX 105246 0002 X
Warning 警告: Do not plug or unplug when energized 不要带电插拔连接器 Do not use the brake as an emergency stop or deceleration device 制动器不能用于紧急制动或减速 Winding protected with PTC140 detector 绕组温度用PTC140监测 To be energized with cable suitable for temperature 80°C 进线电缆耐180°C For converter supply refer to the product manual 变频器, 详情按产品手册	

# Service environment

## Standard environment conditions for operation of HX and HY series explosion-proof servo motors

- Ambient temperature: -20 ~ 40°C
- Altitude: ≤1000 m
- Air pressure: 86 ~ 106 kPa
- Humidity: 5 ~ 95% (no dews)

If the ambient temperature is higher than 40°C, or altitude higher than 1000 m, please refer to the derating principles below. If any other conditions fall out of the above range, please contact ABB.

## Cooling condition and derating

The performance specifications of HDS series servo motors provided in this catalog are obtained at an ambient temperature of 40°C, an altitude below 1,000 and with heat dissipation panel (aluminum alloy, dimensions <sup>1</sup> listed in the table below) equipped. If actual operation environment does not meet these conditions, derating shall be considered in light of specific heat dissipation conditions.

Motor flange (mm)	HXA70/HYA65	HXA10/HYA10	HXA14/HYA13	HXA18/HYA18
Heat dissipation panel dimensions L*W*H (mm)	250*250*6	300*300*8	390*390*10	380*380*8 (two panels)

In derating scenarios, the allowable torque/power of the motor shall be determined according to the table below <sup>1</sup> (when ambient temperature > 40°C or installation altitude > 1000 m). When the temperature value is not an integral multiple of 5°C or the installation altitude value is not an integral multiple of 500m, allowable torque/power should be determined using linear interpolation method or based on the next integral multiple.

Installation altitude (m)	Ambient temperature (°C)				
	<30	40	45	50	55
1000	1.07	1.00	0.96	0.92	0.87
1500	1.04	0.97	0.93	0.89	0.84
2000	1.00	0.94	0.90	0.86	0.82
2500	0.96	0.90	0.86	0.83	0.78
3000	0.92	0.86	0.82	0.79	0.75
3500	0.88	0.82	0.79	0.75	0.71
4000	0.82	0.77	0.74	0.71	0.67
4500	0.76	0.72	0.70	0.67	0.63
5000	0.69	0.67	0.65	0.62	0.58

# Product information

## Feedback & Thermal protection

### Resolver

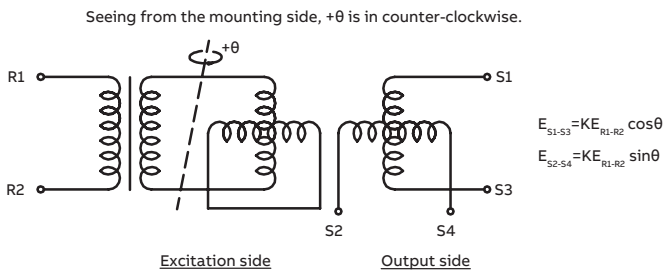

Input voltage <sup>*1</sup>	AC 7 Vrms/10 kHz
Input current	50 mA max
Transformer ratio	0.5±5%
Number of pole-pairs	1
Electrical error	±10' max (mechanical angle)
Phase displacement	0±10° (electrical angle)
Insulation resistance	DC500 V, ≥100 MΩ
Operating temperature	-55°C ~+155°C
Maximum speed	10000 rpm

Notes: \*2, The input voltage is adjusted to improve the resolver's anti-interference. Please contact ABB for details.

### Hiperface absolute encoder

Input voltage	DC +7 ~ +12 V
Input current	60 mA max (idle load)
Sine/cosine periods per revolution	128
Bits per revolution <sup>*2</sup>	19 bit (with 12-bit interpolation of the sine/cosine signals)
Recordable rotation number	1 rotation (single-turn) 4096 rotation (multi-turn)
Memory	1792 Bytes
Protocol	HIPERFACE®
Data transmission type	RS 485
Digital position output frequency	0 ~ 65 kHz
Maximum speed	12000 rpm (single-turn) 9000 rpm (multi-turn)
Direction of rotation	CW (seeing from the mounting side)
Operating temperature	-20°C ~ +110°C

Notes: \*2, The resolution of Hiperface encoder is co-decided by sine/cosine periods per revolution and the interpolation of the sine/cosine signals.

### Thermal protection

The HX series uses 3 x PTC 155 thermistors, while the HY series uses 3 x PTC 140 thermistors. The thermistors are connected in series to protect the 3-phase windings of the motor.

Features of 3xPTC155		Features of 3xPTC140	
Operating temperature	155°C ±5°C	Operating temperature	140°C ±5°C
Resistance at 25°C	≤300Ω	Resistance at 25°C	≤300Ω
Resistance below 135°C	≤750Ω	Resistance below 135°C	≤1650 Ω
Resistance at 150°C	≤1650Ω	Resistance at 145°C	≥3990Ω
Resistance at 160°C	≥3990Ω	Resistance at 155°C	≥12kΩ



# Ordering information

## Cable

### Finished cable type description

E	P	C	B	0	5	0	7	0	0	9	P
---	---	---	---	---	---	---	---	---	---	---	---

#### HX Finished cables

##### Cable length

050: 5 m  
 100: 10 m  
 150: 15 m  
 200: 20 m  
 300: 30 m

##### Motor type - Power cable

70: HXA70  
 10: HXA10  
 14: HXA14, HXA18

##### Motor type - Feedback cable

10: HXA70/10/14/18

##### Power cable - maximum current

09: 9 A (HXA70)  
 15: 15 A (HXA10)  
 20: 20 A (HXA14/18)  
 35: 35 A (HXA14/18)

##### Feedback cable – feedback type

F3: Resolver (MotiFlex e180)  
 F3X: Resolver (MicroFlex e190)  
 F6: Absolute encoder, Hiperface multi-turn (MotiFlex e180, MicroFlex e190)

##### Type

P: Power cable, with brake  
 M: Power cable, without brake  
 F: Feedback cable

# Ordering information

## Cable

### Finished cable type description

C	B	L	C	0	5	0	0	6	F	3	F
---	---	---	---	---	---	---	---	---	---	---	---

#### HY Finished cables

##### Cable length

050: 5 m  
 100: 10 m  
 150: 15 m  
 200: 20 m  
 300v30 m

##### Motor type - Power cable

06: HYA65  
 13: HYA10, HYA13  
 18: HYA18

##### Motor type - Feedback cable

06: HYA65  
 13: HYA10, HYA13, HYA18

##### Power cable - maximum current

06: 6 A  
 12: 12 A  
 20: 20 A  
 35: 35 A

##### Feedback cable – feedback type

F3: Resolver (MotiFlex e180)  
 F3X: Resolver (MicroFlex e190)

##### Type

P: Power cable, with brake  
 M: Power cable, without brake  
 F: Feedback cable

# Drive

## MicroFlex e190

### MicroFlex e190 technical specifications

Type designation	Current at PWM switching frequency 8 kHz (A)					
	Low speed output <sup>1)</sup> (<2 Hz)		200% 3 s		300% 3 s	
	$I_{2n}$	$I_{2max}$	$I_{2n}$	$I_{2max}$	$I_{2n}$	$I_{2max}$
MFE190-04UD-03A0-2	3.00	4.50	3.00	6.00	2.50	7.50
MFE190-04UD-06A0-2	6.00	9.00	6.00	12.00	5.25	15.75
MFE190-04UD-090A-2	9.00	13.50	9.00	18.00	7.50	22.50

### Ratings

MicroFlex e190 has two different overload modes for user selection: 200%, 300%

$I_{2n}$  Rated output current in selected overload mode. The rms current when continuous working should be lower than this.

$I_{2max}$  Max output current (last 3 s) in one duty cycle under the selected overload mode.

<sup>1)</sup> The maximum overload current between 0 Hz and 2 Hz is 150% of rated current

### Technical specifications

Voltage/Frequency	1-phase 200 to 240 V AC $\pm$ 10% 3-phase 200 to 240 V AC $\pm$ 10% 270...340 V DC $\pm$ 10% 50/60 Hz $\pm$ 5%
Efficiency	> 95%
PWM switching frequency/control	8 kHz/Space Vector Modulation
Motor types	Asynchronous motors (standard induction, servo), synchronous motors (servo, high torque), linear servo motors
Braking resistor (external)	0.25 kW nominal/2.7 kW peak 10% duty: 57 $\Omega$ nominal (min 39 $\Omega$ , max 100 $\Omega$ )
<b>Product compliance</b>	
Approvals	CE, cUL/UL, RoHS, UKCA, TÜV functional safety
EMC	EN61800-3 C2 emissions with external filter (30 m motor cable limit)
<b>Environmental limits</b>	
Operating temperature	0 ~ 55°C no derating
Altitude	0...2000 m (6560 ft) above sea level Note: when above 1000 m (3280 ft), with derating of 1%/100 m
Degree of Protection	IP20 (cabinet installation)
<b>Safety</b>	
Safe torque-off (STO)	Two-channel STO function comply with the IEC 61800-5-2, SIL3 PLe as standard

# Drive

## MicroFlex e190

### MicroFlex e190 technical specifications

Technical specifications	
<b>I/O (Standard)</b>	
4 × digital inputs	Opto-isolated 24 V 2 inputs can be programmed as fast position latch inputs 1 μs (feedback device dependent) or pulse direction inputs (max 2 MHz)
3 × digital outputs	Opto-isolated 24 V 100 mA per channel Configurable/programmable function
1 × ±10 V analog input 1 × ±10 V analog output	12 bit . Analog speed/torque control with emulated encoder output
<b>I/O (Expansion option)</b>	
I/O and serial port expansion option	OPT-SIO-1 provides an additional 6 DIs, 4 DOs, 1 AI and a serial port (2-wire RS485 or 4-wire RS422). User installed via the expansion interface of the e190. Note when installed it increases the drive width by approximately 2 mm.
<b>Communications</b>	
EtherCAT (E2=In, E1=Out)	2 RJ45 interfaces for daisy chain connection LED indication built into RJ45 sockets Drive profile: DS402/IEC61800-7-1
POWERLINK (E2, E1)	2 RJ45 interfaces for daisy chain connection LED indication built into RJ45 sockets Drive profile: DS402/IEC61800-7-1
PROFINET IO (E2, E1)	2 RJ45 interfaces for daisy chain connection Communication with the PROFINET masters Drive operation can be customized with a Mint program
EtherNet/IP (E3 port only)	Drive operation can be customized with a Mint program Note: CIP™ sync not supported
Modbus TCP/IP (E3 port only)	Communication with PLCs/Industrial PCs/IO/ HMIs. Drive operation can be customized with a Mint program
E3 Ethernet configuration port	Mint PC support tool Mint WorkBench
7-segment status display	For error and communications notification to quickly identify problems and minimize downtime
NET RUN&NET ERR LEDs	Indicate EtherCAT status of operation in accordance with EtherCAT Technology Group (ETG) guidelines
<b>Motor feedback</b>	
Universal digital feedback	Incremental encoder + Halls, SSI (Synchronous Serial Interface), EnDat 2.1/2.2, 1V pk-pk SinCos, BiSS-B, SmartAbs, SmartInc, Hiperface (8 V)
Dual encoder input	For line shaft following or dual loop control (position/velocity and commutation) to eliminate mechanical errors
Ethernet and motor encoder feedback interfaces	Highly integrated with minimal latency, optimized for demanding motion applications
Encoder splitter	Provides the motor encoder and the 2nd encoder input interface via the option OPT-MF-200
Resolver	Support by option OPT-MF-201 adapter

# Drive

## MicroFlex e190

### MicroFlex e190 connection

#### Simple mounting

- 2 key-holes

#### PE connection for AC supply

#### AC power 1-phase or 3-phase

- 200...240 V AC 50/60 Hz

#### DC bus connection and braking resistor connection

- 270...340 V DC

#### Separate motor power

- Easy to wire
- Easy to isolate the motor during startup/service

#### EMC/PE plate

- Shield bonding
- Motor PE

#### 24 V control supply

- Maintain communications and position after the AC power is removed

#### Simulated encoder output/2<sup>nd</sup> incremental encoder input

- Electronic gearing (line-shaft) or dual-loop feedback operation

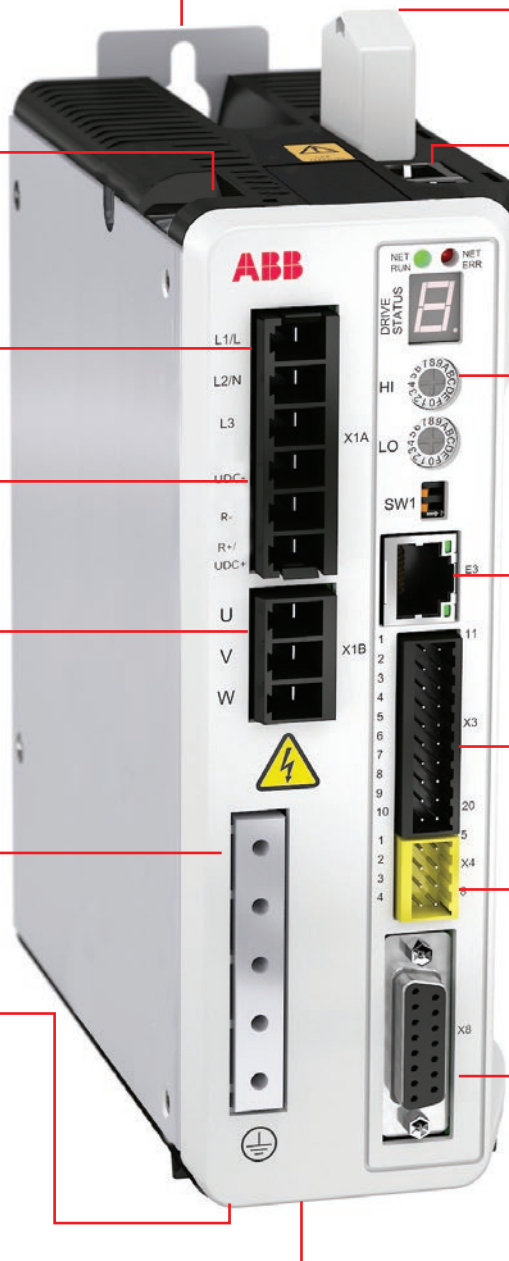

#### Memory unit

- For backing up the configuration information, firmware, and motion programming

#### Ethernet ports E1 and E2

- 2 Ethernet ports with LED indicators for:

- EtherCAT
- POWERLINK
- PROFINET IO

#### Status/Node ID

- 2 LED network status/error indicators
- 7-segment status display
- 2 hex switches for node ID/protocol setting

#### Ethernet port E3

- Port for drive commissioning
- Modbus TCP/IP (server/client)
- EtherNet/IP

#### Digital and analog I/O

- 4 DIs, 3 DOs, 1 AI, 1 AO
- Including 2 latch inputs for position registration <1 μs latency
- Expandable via OPT-SIO-1 to a total of 10 DIs, 7 DOs, 2 AIs, 1 AO + serial port 2-wire RS485 or 4-wire RS422

#### STO PLe SIL 3

- Daisy chain and pulse tolerance
- Allows removal of STO leaving main I/O in-place for system testing

#### Universal encoder interface

- Incremental (ABZ) + Halls
- 1V pk-pk SinCos, SSI, BiSS-B, EnDat 2.1/2.2
- Smart Inc/Smart Abs and Hiperface
- 5 V/8 V selectable encoder supply
- Resolver support via adapter OPT-MF-201

# Drive

## MicroFlex e190

### MicroFlex e190 dimensions

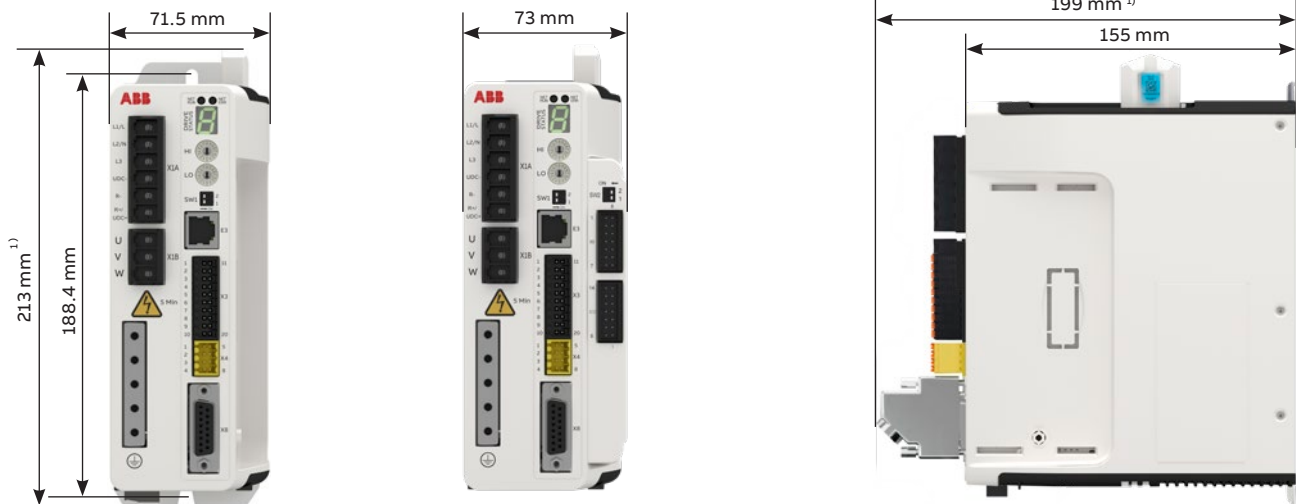

<sup>1)</sup> Approximate dimensions. Allow extra space for feedback and other control cables.

### MicroFlex e190 accessories

Code	Description
OPT-SIO-1	I/O and serial port expansion option
OPT-MF-201	Resolver adapter - in-line adapter in the D-shell housing
OPT-MF-200	Encoder splitter - simplified the wiring for dual encoder connection

### EMC filters

Code	Description		Rated Amps	Leakage current @40 °C	Weight kg (lbs)	Compatible with MFE190-04UD-		
						03A0-2	06A0-2	09A0-2
OFI-01	Foot-mount filter with pre-drilled drive mounting holes and shielded AC input cable, suitable for all ratings. Saves space and install time	1-phase 230 V AC	20	12	0.72 (1.59)	•	•	•
OFI-02	Compact filter with low leakage current		8	0.7	0.33 (0.73)	•		
OFI-03	Compact filter	3-phase	7	33	0.5 (1.1)	•		
JFI-02	Compact filter	230 V AC	16	33	0.8 (1.76)		•	•

All filters meet EN 61800-3, category C2 with motor cables <50 m

### MicroFlex e190 supported accessories and installation methods

Accessories	
Braking chopper	•
Braking resistor	□
AC choke	□
DC choke	-
Mains filter (EMC)/C3	□
Installation features	
Air cooling (fan)	•
Removable connectors Control/Power	• / •
Side by side mounting	•
DIN rail mounting	-
Horizontal mounting	-

• Standard    □ External option    - Not available

For the ordering information about the accessories, see page 59.

# Drive

## MotiFlex e180

### MotiFlex e180 technical specifications

Type designation	Frame size	Current at PWM switching frequency 4/8 kHz (A)			
		200% 3 s		300% 3 s	
		$I_{2n}$	$I_{2max}$	$I_{2n}$	$I_{2max}$
MFE180-04AN-03A0-4	A	3.00	6.00	2.00	6.00
MFE180-04AN-05A0-4	A	4.00	8.00	2.70	8.10
MFE180-04AN-07A0-4	A	4.70	9.40	3.20	9.60
MFE180-04AN-016A-4	B	9.00	18.00	7.00	21.00
MFE180-04AN-024A-4	C	13.50	27.00	10.00	30.00
MFE180-04AN-031A-4	C	21.00	42.00	16.00	48.00
MFE180-04AN-046A-4	C	28.00	56.00	20.00	60.00
MFE180-04AN-060A-4	D	35.00	70.00	25.00	75.00
MFE180-04AN-090A-4	D	55.00	110.00	40.00	120.00

#### Ratings

MotiFlex e180 has two different overload modes as user selection: 200%, 300%

$I_{2n}$	Rated output current in selected overload mode. The rms current when continuous working should be lower than this.
$I_{2max}$	Max output current (last 3 s) in one duty cycle under the selected overload mode.

#### Technical specifications

##### Supply connection

AC Supply	3-phase 200 to 480 V AC $\pm$ 10% 270...650 V DC $\pm$ 10% 50/60 Hz $\pm$ 5%
-----------	--

##### Motor connection

Voltage	3-phase output voltage
Frequency	0... $\pm$ 500 Hz
Motor control	Vector
Motor types	Asynchronous motors (standard induction, servo), synchronous motors (servo, high torque), linear servo motors
Switching frequency/control	4 to 8 kHz/Space Vector Modulation

##### Braking power connection

Braking chopper	As standard in all types
Braking resistor	External resistor connected to drive

##### Product compliance

Approvals	CE, UKCA, cUL/UL
EMC	Category C3 with optional filter (according to EN 61800-3)
Functional safety	Safe torque off (STO according EN 61800-5-2) EN 61508 ed2: SIL 3 EN 62061: SIL CL 3 EN ISO 13849-1: PL e

# Drive

## MotiFlex e180

### MotiFlex e180 technical specifications

Technical specifications	
<b>Environmental limits</b>	
Ambient temperature	
Transport	-40 to +70°C (-40 to +158°F)
Storage	-40 to +70°C (-40 to +158°F)
Operation	0 to +55°C (32 to 131°F), no frost allowed. Note: When above 40°C (104°F), with derating of 2%/1°C
Cooling method	Air-cooled, dry clean air
Altitude	0 to 2000 m (6560 ft) above sea level Note: When above 1000 m (3280 ft), with derating of 1%/100 m (328 ft)
Relative humidity	Max. 95%, no condensation allowed
Degree of protection	IP20 acc. to EN 60529; Open Type acc. to UL 508C
Contamination levels	No conductive dust allowed
Vibration	Sinusoidal vibration (EN 60068-2-6:2008): 2 to 9 Hz: 3.0 mm (0.12") 9 to 200 Hz: 1 g
Shock	Half sine pulse (IEC 60068-2-27:2008): 10 g for 11 ms
EMC	Category C3 with optional filter (according to EN 61800-3)

# Drive

## MotiFlex e180

### MotiFlex e180 connection

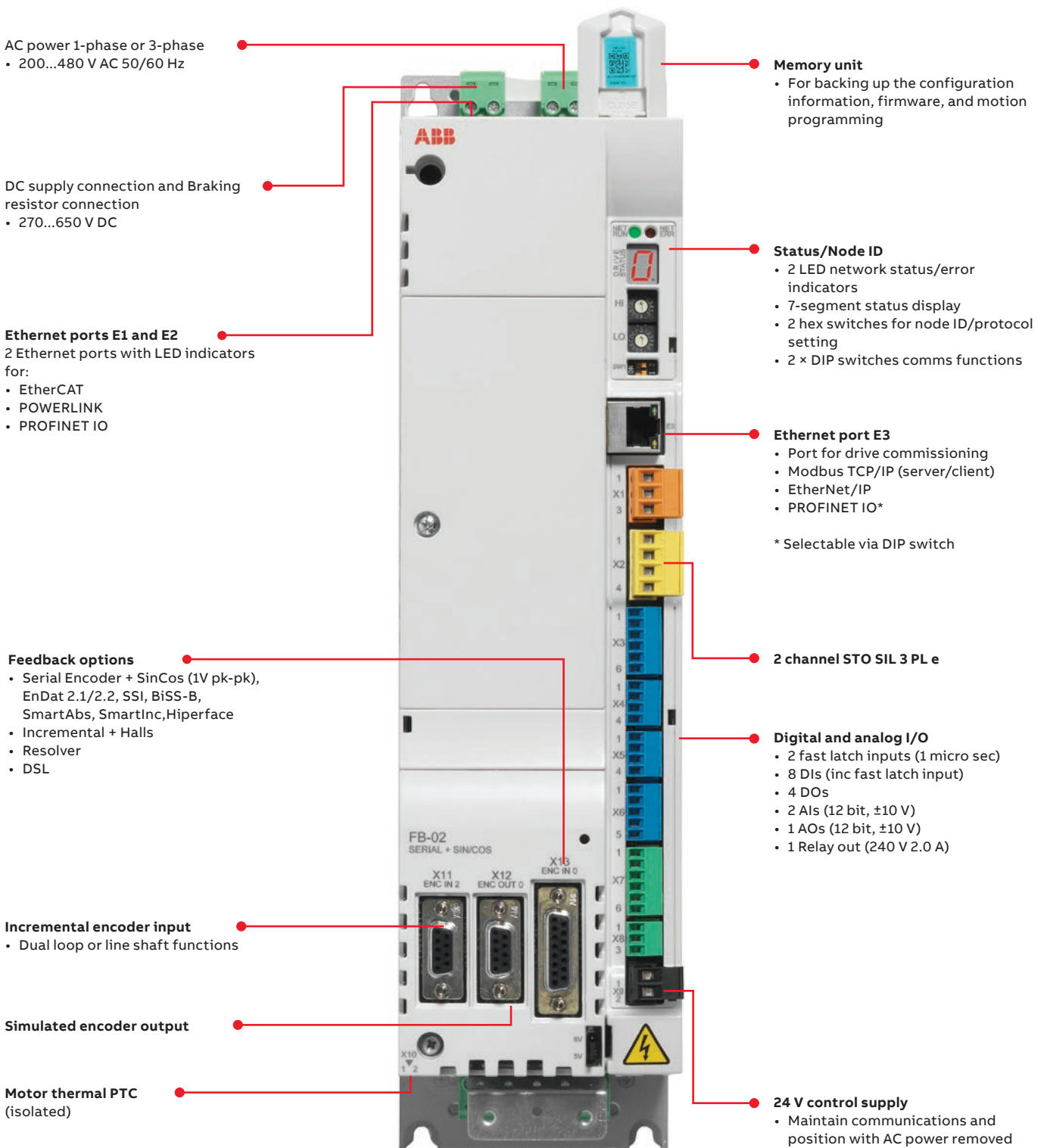

# Drive

## MotiFlex e180

### MotiFlex e180 dimensions

Frame	Height (H)	Width (W)	Depth (D)	Weight
	mm	mm	mm	kg
A	364	90	144	3
B	380	100	221	5
C	467	165	223	10
D	467	220	223	17

Note: Height is the maximum measure without clamping plates.  
In depth, an additional 50 mm should be reserved for feedback cabling.

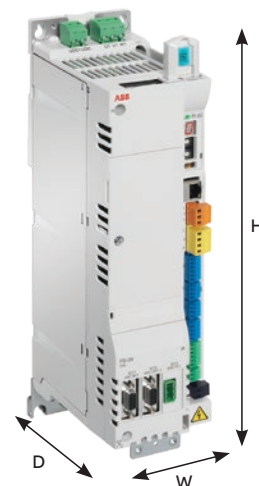

### MotiFlex e180 accessories

Code	Description
FB-01	Encoder Adaptor, for Incremental + Halls (+L517)
FB-02	Encoder Adaptor, for Serial Encoder + SinCos (1V pk-pk) (+L518)
FB-03	Encoder Adaptor, for Resolver (+L516)
FB-04	Encoder Adaptor, for DSL (Stegmann 2 wire solution) (+L530)

### MotiFlex e180 supported accessories and installation methods

Frame size	A	B	C	D
<b>Accessories</b>				
Braking chopper	•	•	•	•
Braking resistor	□	□	□	□
AC choke	□	□	□	□
DC choke	-	-	□	□
Mains filter (EMC) /C3	□	□	□	□
<b>Installation features</b>				
Air cooling (fan)	•	•	•	•
Removable connectors Control/Power	• / •	• / •	• / -	• / -
Side by side mounting	•	•	•	•
DIN rail mounting	•	•	-	-
Horizontal mounting	•	•	•	•

• Standard   □ External option   - Not available

For the ordering information about the accessories, see page 63.

# 230 V product package combination

## MicroFlex e190 and HX servo motor

Motor parameters			Drive type and rating				Package rating		
Motor type	Cont. current (A)	Peak current (A)	Drive type	Mode <sup>1)</sup>	Rated Amps (A)	Peak Amps (A)	Cont Torque (N.m)	Peak Torque (N.m)	Rated power (kW)
HXA705030A	2.3	6	MFE190-04UD-03A0-2	200%	3.0	6.0	1.6	3.4	0.5
				300%	2.5	7.5	1.6	3.4	0.5
HXA707345A	3.1	8.5	MFE190-04UD-06A0-2	200%	6.0	12.0	1.6	3.4	0.7
				300%	5.3	15.8	1.6	3.4	0.7
HXA706930A	2.9	8.5	MFE190-04UD-06A0-2	200%	6.0	12.0	2.2	5.2	0.7
				300%	5.3	15.8	2.2	5.2	0.7
HXA709445A	3.8	12	MFE190-04UD-06A0-2	200%	6.0	12.0	2.0	5.2	0.9
				300%	5.3	15.8	2.0	5.2	0.9
HXA708530A	3.9	12	MFE190-04UD-06A0-2	200%	6.0	12.0	2.7	7.0	0.9
				300%	5.3	15.8	2.7	7.0	0.9
HXA701145A	5	17	MFE190-04UD-06A0-2	200%	6.0	12.0	2.4	5.6	1.0
				300%	5.3	15.8	2.4	6.8	1.0
			MFE190-04UD-09A0-2	200%	9.0	18.0	2.4	7.0	1.1
				300%	7.5	22.5	2.4	7.0	1.1
HXA101330A	5.4	19.1	MFE190-04UD-06A0-2	200%	6.0	12.0	4.3	8.7	1.3
				300%	5.3	15.8	4.3	10.7	1.3
			MFE190-04UD-09A0-2	200%	9.0	18.0	4.3	11.5	1.3
				300%	7.5	22.5	4.3	11.8	1.3
HXA101745A	8	30.5	MFE190-04UD-09A0-2	200%	9.0	18.0	3.8	8.3	1.7
				300%	7.5	22.5	3.6	10.0	1.6
HXA101830A	8.2	30.5	MFE190-04UD-09A0-2	200%	9.0	18.0	5.8	12.3	1.8
				300%	7.5	22.5	5.3	14.7	1.6
HXA101117A	5	18.5	MFE190-04UD-06A0-2	200%	6.0	12.0	6.3	14.0	1.1
				300%	5.3	15.8	6.3	16.8	1.1
			MFE190-04UD-09A0-2	200%	9.0	18.0	6.3	17.6	1.1
				300%	7.5	22.5	6.3	17.7	1.1
HXA101417A	5.9	22.8	MFE190-04UD-06A0-2	200%	6.0	12.0	8.1	16.0	1.4
				300%	5.3	15.8	7.3	19.7	1.3
			MFE190-04UD-09A0-2	200%	9.0	18.0	8.1	21.4	1.4
				300%	7.5	22.5	8.1	23.5	1.4
HXA707950B	2.1	6	MFE190-04UD-03A0-2	200%	3.0	6.0	1.5	3.4	0.8
				300%	2.5	7.5	1.5	3.4	0.8
HXA701050B	2.6	8.5	MFE190-04UD-06A0-2	200%	6.0	12.0	2.0	5.2	1.0
				300%	5.3	15.8	2.0	5.2	1.0
HXA701250B	3.5	12	MFE190-04UD-06A0-2	200%	6.0	12.0	2.4	7.0	1.2
				300%	5.3	15.8	2.4	7.0	1.2
HXA101850B	4.9	19.1	MFE190-04UD-06A0-2	200%	6.0	12.0	3.6	8.5	1.9
				300%	5.3	15.8	3.6	10.8	1.9
			MFE190-04UD-09A0-2	200%	9.0	18.0	3.6	11.5	1.9
				300%	7.5	22.5	3.6	11.8	1.9
HXA102350B	6.8	30.5	MFE190-04UD-09A0-2	200%	9.0	18.0	4.5	11.4	2.4
				300%	7.5	22.5	4.5	14.0	2.4
HXA101830B	5	18.5	MFE190-04UD-06A0-2	200%	6.0	12.0	5.8	13.4	1.8
				300%	5.3	15.8	5.8	16.2	1.8
			MFE190-04UD-09A0-2	200%	9.0	18.0	5.8	17.0	1.8
				300%	7.5	22.5	5.8	17.7	1.8
HXA102330B	5.6	22.8	MFE190-04UD-06A0-2	200%	6.0	12.0	7.5	15.5	2.4
				300%	5.3	15.8	7.1	19.5	2.2
			MFE190-04UD-09A0-2	200%	9.0	18.0	7.5	21.3	2.4
				300%	7.5	22.5	7.5	23.5	2.4
HXA102943B	6.5	36.9	MFE190-04UD-09A0-2	200%	9.0	18.0	6.0	15.8	2.9
				300%	7.5	22.5	6.0	19.0	2.9
HXA141511A	6.7	20.5	MFE190-04UD-09A0-2	200%	9.0	18.0	12.5	31.6	1.50
				300%	7.5	22.5	12.5	36.0	1.50

Notes: 1) The drive offers a 200% and 300% rating mode, which offers a higher peak torque at a slightly reduced rms rating. Highlighted rows provide a full peak and continuous torque of the motor. If the full peak torque is not required by the application, a lower rating drive can be selected in some cases for a more cost effective solution.

# 230 V product package combination

## MicroFlex e190 and HX servo motor

Motor parameters			Drive type and rating				Package rating		
Motor type	Cont. current (A)	Peak current (A)	Drive type	Mode <sup>1)</sup>	Rated Amps (A)	Peak Amps (A)	Cont Torque (N.m)	Peak Torque (N.m)	Rated power (kW)
HXA704730A	1.9	6	MFE190-04UD-03A0-2	200%	3.0	6.0	1.5	3.4	0.5
				300%	2.5	7.5	1.5	3.4	0.5
HXA706145A	2.6	8.5	MFE190-04UD-06A0-2	200%	6.0	12.0	1.3	3.4	0.6
				300%	5.3	15.8	1.3	3.4	0.6
HXA705730A	2.3	8.5	MFE190-04UD-06A0-2	200%	6.0	12.0	1.8	5.2	0.6
				300%	5.3	15.8	1.8	5.2	0.6
HXA706645A	2.7	12	MFE190-04UD-06A0-2	200%	6.0	12.0	1.4	5.2	0.7
				300%	5.3	15.8	1.4	5.2	0.7
HXA706630A	2.9	12	MFE190-04UD-06A0-2	200%	6.0	12.0	2.1	7.0	0.7
				300%	5.3	15.8	2.1	7.0	0.7
HXA707545A	3.2	17	MFE190-04UD-06A0-2	200%	6.0	12.0	1.6	5.6	0.8
				300%	5.3	15.8	1.6	6.8	0.8
			MFE190-04UD-09A0-2	200%	9.0	18.0	1.6	7.0	0.8
				300%	7.5	22.5	1.6	7.0	0.8
HXA109430A	3.5	19.1	MFE190-04UD-06A0-2	200%	6.0	12.0	3.0	8.7	0.9
				300%	5.3	15.8	3.0	10.7	0.9
			MFE190-04UD-09A0-2	200%	9.0	18.0	3.0	11.5	0.9
				300%	7.5	22.5	3.0	11.8	0.9
HXA101130A	4.9	30.5	MFE190-04UD-09A0-2	200%	9.0	18.0	3.7	12.3	1.2
				300%	7.5	22.5	3.7	14.7	1.2
HXA108717A	3.9	18.5	MFE190-04UD-06A0-2	200%	6.0	12.0	4.8	14.0	0.9
				300%	5.3	15.8	4.8	16.8	0.9
			MFE190-04UD-09A0-2	200%	9.0	18.0	4.8	17.6	0.9
				300%	7.5	22.5	4.8	17.7	0.9
HXA101017A	4.2	22.8	MFE190-04UD-06A0-2	200%	6.0	12.0	5.9	16.0	1.1
				300%	5.3	15.8	5.9	19.7	1.1
			MFE190-04UD-09A0-2	200%	9.0	18.0	8.1	21.4	1.4
				300%	7.5	22.5	8.1	23.5	1.4
HXA101325A	5.8	36.9	MFE190-04UD-09A0-2	200%	9.0	18.0	5.0	14.8	1.3
				300%	7.5	22.5	5.0	17.5	1.3
HXA706850B	1.8	6	MFE190-04UD-03A0-2	200%	3.0	6.0	1.3	3.4	0.7
				300%	2.5	7.5	1.3	3.4	0.7
HXA707150B	1.8	8.5	MFE190-04UD-06A0-2	200%	6.0	12.0	1.4	5.2	0.7
				300%	5.3	15.8	1.4	5.2	0.7
HXA707050B	1.9	12	MFE190-04UD-06A0-2	200%	6.0	12.0	1.3	7.0	0.7
				300%	5.3	15.8	1.3	7.0	0.7
HXA109430B	3.5	19.1	MFE190-04UD-06A0-2	200%	6.0	12.0	3.0	8.5	0.9
				300%	5.3	15.8	3.0	10.8	0.9
			MFE190-04UD-09A0-2	200%	9.0	18.0	3.0	11.5	0.9
				300%	7.5	22.5	3.0	11.8	0.9
HXA101130B	3	18.5	MFE190-04UD-06A0-2	200%	6.0	12.0	3.7	13.4	1.2
				300%	5.3	15.8	3.7	16.2	1.2
			MFE190-04UD-09A0-2	200%	9.0	18.0	3.7	17.0	1.2
				300%	7.5	22.5	3.7	17.7	1.2
HXA102330B	3.3	22.8	MFE190-04UD-06A0-2	200%	6.0	12.0	4.5	15.5	1.4
				300%	5.3	15.8	4.5	19.5	1.4
			MFE190-04UD-09A0-2	200%	9.0	18.0	4.5	21.3	1.4
				300%	7.5	22.5	4.5	23.5	1.4
HXA141211A	5.5	20.5	MFE190-04UD-09A0-2	200%	9.0	18.0	10.3	31.6	1.24
				300%	7.5	22.5	10.3	36.0	1.24
HXA141510A	6.5	30.2	MFE190-04UD-09A0-2	200%	9.0	18.0	12.6	28.6	1.51
				300%	7.5	22.5	12.6	35.8	1.51

Notes: 1) The drive offers a 200% and 300% rating mode, which offers a higher peak torque at a slightly reduced rms rating. Highlighted rows provide a full peak and continuous torque of the motor. If the full peak torque is not required by the application, a lower rating drive can be selected in some cases for a more cost effective solution.

# 230 V product package combination

## MotiFlex e180 and HX servo motor

Motor parameters			Drive type and rating				Package rating		
Motor type	Cont. current (A)	Peak current (A)	Drive type	Mode <sup>1)</sup>	Rated Amps (A)	Peak Amps (A)	Cont Torque (N.m)	Peak Torque (N.m)	Rated power (kW)
HXA141511A	6.7	20.5	MFE180-04AN-016A-4	200%	9.0	18.0	12.5	31.6	1.5
				300%	7.0	21.0	12.5	36.0	1.5
HXA142217A	10.0	30.6	MFE180-04AN-024A-4	200%	13.5	27.0	12.0	31.8	2.2
				300%	10.0	30.0	12.0	35.3	2.2
				200%	21.0	42.0	12.0	36.0	2.2
				300%	16.0	48.0	12.0	36.0	2.2
HXA142725A	12.5	41.1	MFE180-04AN-031A-4	200%	21.0	42.0	10.5	36.0	2.7
				300%	16.0	48.0	10.5	36.0	2.7
HXA142011A	9.0	30.2	MFE180-04AN-024A-4	200%	13.5	27.0	16.5	42.9	2.0
				300%	10.0	30.0	16.5	47.7	2.0
				200%	21.0	42.0	16.5	48.0	2.0
				300%	16.0	48.0	16.5	48.0	2.0
HXA142817A	12.5	45.3	MFE180-04AN-031A-4	200%	21.0	42.0	15.5	44.5	2.8
				300%	16.0	48.0	15.5	48.0	2.8
HXA143625A	18.7	70.8	MFE180-04AN-046A-4	200%	28.0	56.0	14.0	38.0	3.6
				300%	20.0	60.0	14.0	40.7	3.6
				200%	35.0	70.0	14.0	47.5	3.6
				300%	25.0	75.0	14.0	48.0	3.6
HXA142511A	12.5	44	MFE180-04AN-031A-4	200%	21.0	42.0	20.5	66.8	2.5
				300%	16.0	48.0	20.5	70.0	2.5
HXA143417A	18.5	68.8	MFE180-04AN-046A-4	200%	28.0	56.0	18.5	57.0	3.4
				300%	20.0	60.0	18.5	61.0	3.4
				200%	35.0	70.0	18.5	70.0	3.4
				300%	25.0	75.0	18.5	70.0	3.4
HXA185011A	21.0	51.3	MFE180-04AN-060A-4	200%	35.0	70.0	42.0	105.0	5.0
				300%	25.0	75.0	42.0	105.0	5.0
HXA187520A	31.5	90.6	MFE180-04AN-090A-4	200%	55.0	110.0	36.0	105.0	7.5
				300%	40.0	120.0	36.0	105.0	7.5
HXA186211A	25.5	70.3	MFE180-04AN-060A-4	200%	35.0	70.0	52.0	139.4	6.2
				300%	25.0	75.0	51.0	140.0	6.1
				200%	55.0	110.0	52.0	140.0	6.2
				300%	40.0	120.0	52.0	140.0	6.2
HXA189020A	43.0	137.6	MFE180-04AN-090A-4	200%	55.0	110.0	43.0	111.9	9.0
				300%	40.0	120.0	40.0	122.1	8.4
HXA186809A	31.0	93	MFE180-04AN-090A-4	200%	55.0	110.0	72.5	210.0	6.8
				300%	40.0	120.0	72.5	210.0	6.8
HXA189915A	40.5	137.6	MFE180-04AN-090A-4	200%	55.0	110.0	63.0	167.9	9.9
				300%	40.0	120.0	62.2	183.1	9.8

# 230 V product package combination

## MotiFlex e180 and HX servo motor

Motor parameters			Drive type and rating				Package rating		
Motor type	Cont. current (A)	Peak current (A)	Drive type	Mode <sup>1)</sup>	Rated Amps (A)	Peak Amps (A)	Cont Torque (N.m)	Peak Torque (N.m)	Rated power (kW)
HXA141211A	5.5	20.5	MFE180-04AN-016A-4	200%	9.0	18.0	10.3	31.6	1.2
				300%	7.0	21.0	10.3	36.0	1.2
HXA141617A	7.3	30.6	MFE180-04AN-024A-4	200%	13.5	27.0	9.0	31.8	1.6
				300%	10.0	30.0	9.0	35.3	1.6
			MFE180-04AN-031A-4	200%	21.0	42.0	9.0	36.0	1.6
				300%	16.0	48.0	9.0	36.0	1.6
HXA142025A	8.3	41.1	MFE180-04AN-024A-4	200%	13.5	27.0	7.7	23.6	2.0
				300%	10.0	30.0	7.7	26.3	2.0
			MFE180-04AN-031A-4	200%	21.0	42.0	7.7	36.0	2.0
				300%	16.0	48.0	7.7	36.0	2.0
HXA141510A	6.5	30.2	MFE180-04AN-016A-4	200%	9.0	18.0	12.6	28.6	1.5
				300%	7.0	21.0	12.6	33.4	1.5
			MFE180-04AN-024A-4	200%	13.5	27.0	12.6	42.9	1.5
				300%	10.0	30.0	12.6	47.7	1.5
HXA141917A	8.4	45.3	MFE180-04AN-024A-4	200%	13.5	27.0	10.8	28.6	2.0
				300%	10.0	30.0	10.8	31.8	2.0
			MFE180-04AN-031A-4	200%	21.0	42.0	10.8	44.5	2.0
				300%	16.0	48.0	10.8	48.0	2.0
HXA142020A	12.2	70.8	MFE180-04AN-031A-4	200%	21.0	42.0	10.0	28.5	2.1
				300%	16.0	48.0	10.0	32.5	2.1
			MFE180-04AN-046A-4	200%	28.0	56.0	10.0	38.0	2.1
				300%	20.0	60.0	10.0	40.7	2.1
			MFE180-04AN-060A-4	200%	35.0	70.0	10.0	47.5	2.1
				300%	25.0	75.0	10.0	48.0	2.1
HXA141611A	8.1	44	MFE180-04AN-024A-4	200%	13.5	27.0	13.3	43.0	1.6
				300%	10.0	30.0	13.3	47.7	1.6
			MFE180-04AN-031A-4	200%	21.0	42.0	13.3	66.8	1.6
				300%	16.0	48.0	13.3	70.0	1.6
			MFE180-04AN-024A-4	200%	13.5	27.0	10.3	27.5	1.9
				300%	10.0	30.0	10.3	30.5	1.9
MFE180-04AN-031A-4	200%	21.0		42.0	10.3	42.7	1.9		
	300%	16.0		48.0	10.3	48.8	1.9		
MFE180-04AN-046A-4	200%	28.0	56.0	10.3	57.0	1.9			
	300%	20.0	60.0	10.3	61.0	1.9			
	MFE180-04AN-060A-4	200%	35.0	70.0	10.3	70.0	1.9		
		300%	25.0	75.0	10.3	70.0	1.9		
HXA184111A	17.4	51.3	MFE180-04AN-046A-4	200%	28.0	56.0	34.8	105.0	4.2
				300%	20.0	60.0	34.8	105.0	4.2
HXA185820A	24.5	90.6	MFE180-04AN-060A-4	200%	35.0	70.0	28.0	81.1	5.9
				300%	25.0	75.0	28.0	86.9	5.9
			MFE180-04AN-090A-4	200%	55.0	110.0	28.0	105.0	5.9
				300%	40.0	120.0	28.0	105.0	5.9
HXA184711A	18.6	70.3	MFE180-04AN-046A-4	200%	28.0	56.0	39.6	111.5	4.8
				300%	20.0	60.0	39.6	119.5	4.8
			MFE180-04AN-060A-4	200%	35.0	70.0	39.6	139.4	4.8
				300%	25.0	75.0	39.6	140.0	4.8

Notes: 1) The drive offers a 200% and 300% rating mode, which offers a higher peak torque at a slightly reduced rms rating. Highlighted rows provide a full peak and continuous torque of the motor. If the full peak torque is not required by the application, a lower rating drive can be selected in some cases for a more cost effective solution.

## 230 V product package combination

### MotiFlex e180 and HX servo motor

Motor parameters			Drive type and rating				Package rating		
Motor type	Cont. current (A)	Peak current (A)	Drive type	Mode <sup>1)</sup>	Rated Amps (A)	Peak Amps (A)	Cont Torque (N.m)	Peak Torque (N.m)	Rated power (kW)
HXA185315A	31.5	137.6	MFE180-04AN-090A-4	200%	55.0	110.0	34.0	111.9	5.3
				300%	40.0	120.0	34.0	122.1	5.3
HXA185109A	22.9	93	MFE180-04AN-060A-4	200%	35.0	70.0	54.2	158.1	5.1
				300%	25.0	75.0	54.2	169.4	5.1
			MFE180-04AN-090A-4	200%	55.0	110.0	54.2	210.0	5.1
				300%	40.0	120.0	54.2	210.0	5.1
HXA186115A	24.5	137.6	MFE180-04AN-060A-4	200%	35.0	70.0	39.0	106.8	6.1
				300%	25.0	75.0	39.0	114.5	6.1
			MFE180-04AN-090A-4	200%	55.0	110.0	39.0	167.9	6.1
				300%	40.0	120.0	39.0	183.1	6.1

# 230 V product package combination

## MicroFlex e190 and HY servo motor

Motor parameters			Drive type and rating				Package rating		
Motor type	Cont. current (A)	Peak current (A)	Drive type	Mode <sup>1)</sup>	Rated Amps (A)	Peak Amps (A)	Cont Torque (N.m)	Peak Torque (N.m)	Rated power (kW)
HYA655030A	4.3	14.7	MFE190-04UD-06A0-2	200%	6.0	12.0	1.6	3.7	0.5
				300%	5.3	15.8	1.6	4.5	0.5
			MFE190-04UD-09A0-2	200%	9.0	18.0	1.6	4.5	0.5
				300%	7.5	22.5	1.6	4.5	0.5
HYA101030A	5.6	20	MFE190-04UD-06A0-2	200%	6.0	12.0	3.2	5.8	1.0
				300%	5.3	15.8	3.0	7.3	1.0
			MFE190-04UD-09A0-2	200%	9.0	18.0	3.2	8.6	1.0
				200%	9.0	18.0	3.2	8.6	1.0
HYA101730A	9.1	36.2	MFE190-04UD-09A0-2	200%	9.0	18.0	3.2	8.6	1.0
				200%	9.0	18.0	3.2	8.6	1.0

Notes: 1) The drive offers a 200% and 300% rating mode, which offers a higher peak torque at a slightly reduced rms rating. Highlighted rows provide a full peak and continuous torque of the motor. If the full peak torque is not required by the application, a lower rating drive can be selected in some cases for a more cost effective solution.

# 400 V product package combination

## MotiFlex e180 and HX servo motor

Motor parameters			Drive type and rating				Package rating		
Motor type	Cont. current (A)	Peak current (A)	Drive type	Mode <sup>1)</sup>	Rated Amps (A)	Peak Amps (A)	Cont Torque (N.m)	Peak Torque (N.m)	Rated power (kW)
HXA705030A	2.3	6	MFE180-04AN-03A0-4	200%	3.0	6.0	1.6	3.4	0.5
				300%	2.0	6.0	1.4	3.4	0.4
HXA707345A	3.1	8.5	MFE180-04AN-05A0-4	200%	4.0	8.0	1.6	3.3	0.7
				300%	2.7	8.1	1.4	3.3	0.6
			MFE180-04AN-07A0-4	200%	4.7	9.4	1.6	3.4	0.7
				300%	3.2	9.6	1.6	3.4	0.7
HXA706930A	2.9	8.5	MFE180-04AN-05A0-4	200%	4.0	8.0	2.2	5.0	0.7
				300%	2.7	8.1	2.0	5.1	0.6
			MFE180-04AN-07A0-4	200%	4.7	9.4	2.2	5.2	0.7
				300%	3.2	9.6	2.2	5.2	0.7
HXA709445A	3.8	12	MFE180-04AN-05A0-4	200%	4.0	8.0	2.0	4.0	0.9
				300%	2.7	8.1	1.4	4.1	0.7
			MFE180-04AN-07A0-4	200%	4.7	9.4	2.0	4.6	0.9
				300%	3.2	9.6	1.7	4.7	0.8
			MFE180-04AN-016A-4	200%	9.0	18.0	2.0	5.2	0.9
				300%	7.0	21.0	2.0	5.2	0.9
HXA708530A	3.9	12	MFE180-04AN-05A0-4	200%	4.0	8.0	2.7	5.3	0.9
				300%	2.7	8.1	1.9	5.4	0.6
			MFE180-04AN-07A0-4	200%	4.7	9.4	2.7	6.1	0.9
				300%	3.2	9.6	2.2	6.2	0.7
			MFE180-04AN-016A-4	200%	9.0	18.0	2.7	7.0	0.9
				300%	7.0	21.0	2.7	7.0	0.9
HXA701145A	5	17	MFE180-04AN-016A-4	200%	9.0	18.0	2.4	7.0	1.2
				300%	7.0	21.0	2.4	7.0	1.2
HXA101330A	5.4	19.1	MFE180-04AN-016A-4	200%	9.0	18.0	4.3	11.8	1.4
				300%	7.0	21.0	4.3	11.8	1.4
HXA101745A	8	30.5	MFE180-04AN-016A-4	200%	9.0	18.0	3.8	8.3	1.8
				300%	7.0	21.0	3.3	9.4	1.6
			MFE180-04AN-024A-4	200%	13.5	27.0	3.8	11.2	1.8
				300%	10.0	30.0	3.8	11.7	1.8
			MFE180-04AN-031A-4	200%	21.0	42.0	3.8	11.8	1.8
				300%	16.0	48.0	3.8	11.8	1.8
HXA101830A	8.2	30.5	MFE180-04AN-016A-4	200%	9.0	18.0	5.8	12.3	1.8
				300%	7.0	21.0	5.1	14.0	1.6
			MFE180-04AN-024A-4	200%	13.5	27.0	5.8	16.6	1.8
				300%	10.0	30.0	5.8	17.5	1.8
			MFE180-04AN-031A-4	200%	21.0	42.0	5.8	17.7	1.8
				300%	16.0	48.0	5.8	17.7	1.8
HXA102245A	9.9	42	MFE180-04AN-024A-4	200%	13.5	27.0	4.7	12.0	2.2
				300%	10.0	30.0	4.7	13.2	2.2
			MFE180-04AN-031A-4	200%	21.0	42.0	4.7	17.7	2.2
				300%	16.0	48.0	4.7	17.7	2.2
HXA101117A	5	18.5	MFE180-04AN-016A-4	200%	9.0	18.0	6.3	17.3	1.1
				300%	7.0	21.0	6.3	17.7	1.1
			MFE180-04AN-024A-4	200%	13.5	27.0	6.3	17.7	1.1
				300%	10.0	30.0	6.3	17.7	1.1
HXA101417A	5.9	22.8	MFE180-04AN-016A-4	200%	9.0	18.0	8.1	20.5	1.5
				300%	7.0	21.0	8.1	22.8	1.5
			MFE180-04AN-024A-4	200%	13.5	27.0	8.1	23.6	1.5
				300%	10.0	30.0	8.1	23.6	1.5
HXA102025A	9.2	36.9	MFE180-04AN-024A-4	200%	13.5	27.0	7.7	19.7	2.0
				300%	10.0	30.0	7.7	21.3	2.0
			MFE180-04AN-031A-4	200%	21.0	42.0	7.7	23.6	2.0
				300%	16.0	48.0	7.7	23.6	2.0

# 400 V product package combination

## MotiFlex e180 and HX servo motor

Motor parameters			Drive type and rating				Package rating		
Motor type	Cont. current (A)	Peak current (A)	Drive type	Mode <sup>1)</sup>	Rated Amps (A)	Peak Amps (A)	Cont Torque (N.m)	Peak Torque (N.m)	Rated power (kW)
HXA707950B	2.1	6	MFE180-04AN-03A0-4	200%	3.0	6.0	1.5	3.4	0.8
				300%	2.0	6.0	1.4	3.4	0.8
			MFE180-04AN-05A0-4	200%	4.0	8.0	1.5	3.4	0.8
				300%	2.7	8.1	1.5	3.4	0.8
HXA701050B	2.6	8.5	MFE180-04AN-03A0-4	200%	3.0	6.0	2.0	4.2	1.0
				300%	2.0	6.0	1.5	4.2	0.8
			MFE180-04AN-05A0-4	200%	4.0	8.0	2.0	5.1	1.0
				300%	2.7	8.1	2.0	5.1	1.0
			MFE180-04AN-07A0-4	200%	4.7	9.4	2.0	5.2	1.0
				300%	3.2	9.6	2.0	5.2	1.0
HXA701250B	3.5	12	MFE180-04AN-05A0-4	200%	4.0	8.0	2.4	5.1	1.2
				300%	2.7	8.1	1.8	5.1	1.0
			MFE180-04AN-07A0-4	200%	4.7	9.4	2.4	5.8	1.2
				300%	3.2	9.6	2.2	5.9	1.1
			MFE180-04AN-016A-4	200%	9.0	18.0	2.4	7.0	1.2
				300%	7.0	21.0	2.4	7.0	1.2
HXA101850B	4.9	19.1	MFE180-04AN-016A-4	200%	9.0	18.0	3.6	11.8	1.9
				300%	7.0	21.0	3.6	11.8	1.9
			MFE180-04AN-016A-4	200%	9.0	18.0	4.5	11.7	2.3
				300%	7.0	21.0	4.5	13.4	2.3
HXA102350B	6.8	30.5	MFE180-04AN-024A-4	200%	13.5	27.0	4.5	16.4	2.3
				300%	10.0	30.0	4.5	17.5	2.3
			MFE180-04AN-031A-4	200%	21.0	42.0	4.5	17.7	2.3
				300%	16.0	48.0	4.5	17.7	2.3
			MFE180-04AN-016A-4	200%	9.0	18.0	5.8	17.3	1.8
				300%	7.0	21.0	5.8	17.7	1.8
HXA101830B	5	18.5	MFE180-04AN-024A-4	200%	13.5	27.0	5.8	17.7	1.8
				300%	10.0	30.0	5.8	17.7	1.8
			MFE180-04AN-016A-4	200%	9.0	18.0	7.5	21.0	2.4
				300%	7.0	21.0	7.5	23.0	2.4
HXA102330B	5.6	22.8	MFE180-04AN-024A-4	200%	13.5	27.0	7.5	23.6	2.4
				300%	10.0	30.0	7.5	23.6	2.4
			MFE180-04AN-016A-4	200%	9.0	18.0	6.0	15.8	2.9
				300%	7.0	21.0	6.0	18.0	2.9
HXA102943B	6.5	36.9	MFE180-04AN-024A-4	200%	13.5	27.0	6.0	21.6	2.9
				300%	10.0	30.0	6.0	22.6	2.9
			MFE180-04AN-031A-4	200%	21.0	42.0	6.0	23.6	2.9
				300%	16.0	48.0	6.0	23.6	2.9
			MFE180-04AN-016A-4	200%	9.0	18.0	12.0	31.6	2.5
				300%	7.0	21.0	12.0	36.0	2.5
HXA143230B	8.7	30.6	MFE180-04AN-024A-4	200%	13.5	27.0	10.5	31.8	3.3
				300%	10.0	30.0	10.5	35.3	3.3
			MFE180-04AN-031A-4	200%	21.0	42.0	10.5	36.0	3.3
				300%	16.0	48.0	10.5	36.0	3.3
HXA143843B	10.0	41.1	MFE180-04AN-024A-4	200%	13.5	27.0	8.5	23.6	3.8
				300%	10.0	30.0	8.5	26.3	3.8
			MFE180-04AN-031A-4	200%	21.0	42.0	8.5	36.0	3.8
				300%	16.0	48.0	8.5	36.0	3.8
HXA143120B	8.2	30.2	MFE180-04AN-024A-4	200%	13.5	27.0	15.0	42.9	3.1
				300%	10.0	30.0	15.0	47.7	3.1
			MFE180-04AN-031A-4	200%	21.0	42.0	15.0	48.0	3.1
				300%	16.0	48.0	15.0	48.0	3.1

Notes: 1) The drive offers a 200% and 300% rating mode, which offers a higher peak torque at a slightly reduced rms rating. Highlighted rows provide a full peak and continuous torque of the motor. If the full peak torque is not required by the application, a lower rating drive can be selected in some cases for a more cost effective solution.

# 400 V product package combination

## MotiFlex e180 and HX servo motor

Motor parameters			Drive type and rating				Package rating		
Motor type	Cont. current (A)	Peak current (A)	Drive type	Mode <sup>1)</sup>	Rated Amps (A)	Peak Amps (A)	Cont Torque (N.m)	Peak Torque (N.m)	Rated power (kW)
HXA144030B	10.6	45.3	MFE180-04AN-031A-4	200%	21.0	42.0	13.0	44.5	4.1
				300%	16.0	48.0	13.0	48.0	4.1
HXA144643B	14.0	70.8	MFE180-04AN-031A-4	200%	21.0	42.0	10.3	28.5	4.6
				300%	16.0	48.0	10.3	32.5	4.6
			MFE180-04AN-046A-4	200%	28.0	56.0	10.3	38.0	4.6
				300%	20.0	60.0	10.3	40.7	4.6
			MFE180-04AN-060A-4	200%	35.0	70.0	10.3	47.5	4.6
				300%	25.0	75.0	10.3	48.0	4.6
HXA143820B	11.1	44	MFE180-04AN-031A-4	200%	21.0	42.0	18.3	66.8	3.8
				300%	16.0	48.0	18.3	70.0	3.8
HXA144630B	14.8	68.8	MFE180-04AN-031A-4	200%	21.0	42.0	14.8	42.7	4.6
				300%	16.0	48.0	14.8	48.8	4.6
			MFE180-04AN-046A-4	200%	28.0	56.0	14.8	57.0	4.6
				300%	20.0	60.0	14.8	61.0	4.6
			MFE180-04AN-060A-4	200%	35.0	70.0	14.8	70.0	4.6
				300%	25.0	75.0	14.8	70.0	4.6
HXA187520B	17.9	51.3	MFE180-04AN-046A-4	200%	28.0	56.0	36.0	105.0	7.5
				300%	20.0	60.0	36.0	105.0	7.5
HXA188735B	20.5	90.6	MFE180-04AN-060A-4	200%	35.0	70.0	24.0	81.1	8.8
				300%	25.0	75.0	24.0	86.9	8.8
			MFE180-04AN-090A-4	200%	55.0	110.0	24.0	105.0	8.8
				300%	40.0	120.0	24.0	105.0	8.8
HXA189020B	21.2	70.3	MFE180-04AN-060A-4	200%	35.0	70.0	43.0	139.4	9.0
				300%	25.0	75.0	43.0	140.0	9.0
			MFE180-04AN-090A-4	200%	55.0	110.0	43.0	140.0	9.0
				300%	40.0	120.0	43.0	140.0	9.0
HXA189430B	30.0	137.6	MFE180-04AN-090A-4	200%	55.0	110.0	30.0	111.9	9.4
				300%	40.0	120.0	30.0	122.1	9.4
HXA189815B	27.0	93	MFE180-04AN-090A-4	200%	55.0	110.0	63.0	210.0	9.9
				300%	40.0	120.0	63.0	210.0	9.9
HXA181225B	29.6	137.6	MFE180-04AN-090A-4	200%	55.0	110.0	46.0	167.9	12.0
				300%	40.0	120.0	46.0	183.1	12.0

# 400 V product package combination

## MotiFlex e180 and HX servo motor

Motor parameters			Drive type and rating				Package rating		
Motor type	Cont. current (A)	Peak current (A)	Drive type	Mode <sup>1)</sup>	Rated Amps (A)	Peak Amps (A)	Cont Torque (N.m)	Peak Torque (N.m)	Rated power (kW)
HXA704730A	1.9	6	MFE180-04AN-03A0-4	200%	3.0	6.0	1.5	3.4	0.5
				300%	2.0	6.0	1.5	3.4	0.5
HXA706145A	2.6	8.5	MFE180-04AN-05A0-4	200%	4.0	8.0	1.3	3.3	0.6
				300%	2.7	8.1	1.3	3.3	0.6
HXA705730A	2.3	8.5	MFE180-04AN-05A0-4	200%	4.0	8.0	1.8	5.0	0.6
				300%	2.7	8.1	1.8	5.1	0.5
HXA706645A	2.7	12	MFE180-04AN-05A0-4	200%	4.0	8.0	1.4	4.0	0.7
				300%	2.7	8.1	1.4	4.1	0.7
			MFE180-04AN-07A0-4	200%	4.7	9.4	1.4	4.6	0.7
				300%	3.2	9.6	1.4	4.7	0.7
			MFE180-04AN-016A-4	200%	9.0	18.0	1.4	5.2	0.7
				300%	7.0	21.0	1.4	5.2	0.7
HXA706630A	2.9	12	MFE180-04AN-05A0-4	200%	4.0	8.0	2.1	5.3	0.7
				300%	2.7	8.1	1.9	5.4	0.6
			MFE180-04AN-07A0-4	200%	4.7	9.4	2.1	6.1	0.7
				300%	3.2	9.6	2.1	6.2	0.7
			MFE180-04AN-016A-4	200%	9.0	18.0	2.1	7.0	0.7
				300%	7.0	21.0	2.1	7.0	0.7
HXA707545A	3.2	17	MFE180-04AN-016A-4	200%	9.0	18.0	1.6	7.0	0.8
				300%	7.0	21.0	1.6	7.0	0.8
HXA109430A	3.5	19.1	MFE180-04AN-016A-4	200%	9.0	18.0	3.0	11.8	0.9
				300%	7.0	21.0	3.0	11.8	0.9
HXA101130A	4.9	30.5	MFE180-04AN-016A-4	200%	9.0	18.0	3.7	12.3	1.1
				300%	7.0	21.0	3.7	14.0	1.1
			MFE180-04AN-024A-4	200%	13.5	27.0	3.7	16.6	1.1
				300%	10.0	30.0	3.7	17.5	1.1
			MFE180-04AN-031A-4	200%	21.0	42.0	3.7	17.7	1.1
				300%	16.0	48.0	3.7	17.7	1.1
HXA108717A	3.9	18.5	MFE180-04AN-016A-4	200%	9.0	18.0	4.8	17.3	0.9
				300%	7.0	21.0	4.8	17.7	0.9
			MFE180-04AN-024A-4	200%	13.5	27.0	4.8	17.7	0.9
				300%	10.0	30.0	4.8	17.7	0.9
HXA101017A	4.2	22.8	MFE180-04AN-016A-4	200%	9.0	18.0	5.9	20.5	1.1
				300%	7.0	21.0	5.9	22.8	1.1
			MFE180-04AN-024A-4	200%	13.5	27.0	5.9	23.6	1.1
				300%	10.0	30.0	5.9	23.6	1.1
HXA101325A	5.8	36.9	MFE180-04AN-016A-4	200%	9.0	18.0	5.0	14.6	1.3
				300%	7.0	21.0	5.0	16.5	1.3
			MFE180-04AN-024A-4	200%	13.5	27.0	5.0	19.7	1.3
				300%	10.0	30.0	5.0	21.3	1.3
			MFE180-04AN-031A-4	200%	21.0	42.0	5.0	23.6	1.3
				300%	16.0	48.0	5.0	23.6	1.3
HXA706850B	1.8	6	MFE180-04AN-03A0-4	200%	3.0	6.0	1.3	3.4	0.7
				300%	2.0	6.0	1.3	3.4	0.7
HXA707150B	1.8	8.5	MFE180-04AN-03A0-4	200%	3.0	6.0	1.4	4.2	0.7
				300%	2.0	6.0	1.4	4.2	0.7
			MFE180-04AN-05A0-4	200%	4.0	8.0	1.4	5.1	0.7
				300%	2.7	8.1	1.4	5.1	0.7
HXA707050B	1.9	12	MFE180-04AN-05A0-4	200%	4.0	8.0	1.3	5.1	0.7
				300%	2.7	8.1	1.3	5.1	0.7
			MFE180-04AN-07A0-4	200%	4.7	9.4	1.3	5.8	0.7
				300%	3.2	9.6	1.3	5.9	0.7
			MFE180-04AN-016A-4	200%	9.0	18.0	1.3	7.0	0.7
				300%	7.0	21.0	1.3	7.0	0.7

Notes: 1) The drive offers a 200% and 300% rating mode, which offers a higher peak torque at a slightly reduced rms rating. Highlighted rows provide a full peak and continuous torque of the motor. If the full peak torque is not required by the application, a lower rating drive can be selected in some cases for a more cost effective solution.

# 400 V product package combination

## MotiFlex e180 and HX servo motor

Motor parameters			Drive type and rating				Package rating		
Motor type	Cont. current (A)	Peak current (A)	Drive type	Mode <sup>1)</sup>	Rated Amps (A)	Peak Amps (A)	Cont Torque (N.m)	Peak Torque (N.m)	Rated power (kW)
HXA109430B	3.5	19.1	MFE180-04AN-016A-4	200%	9.0	18.0	3.0	11.8	0.9
				300%	7.0	21.0	3.0	11.8	0.9
HXA101130B	3	18.5	MFE180-04AN-07A0-4	200%	4.7	9.4	3.7	10.2	1.2
				300%	3.2	9.6	3.7	10.4	1.2
			MFE180-04AN-016A-4	200%	9.0	18.0	3.7	17.3	1.2
				300%	7.0	21.0	3.7	17.7	1.2
HXA101430B	3.3	22.8	MFE180-04AN-024A-4	200%	13.5	27.0	3.7	17.7	1.2
				300%	10.0	30.0	3.7	17.7	1.2
			MFE180-04AN-016A-4	200%	9.0	18.0	4.5	21.0	1.4
				300%	7.0	21.0	4.5	23.0	1.4
HXA141820B	4.8	20.5	MFE180-04AN-016A-4	200%	9.0	18.0	9.0	31.6	1.9
				300%	7.0	21.0	9.0	36.0	1.9
			MFE180-04AN-024A-4	200%	13.5	27.0	6.8	21.2	2.1
HXA142030B	5.5	30.6	MFE180-04AN-016A-4	300%	7.0	21.0	6.8	24.7	2.1
				MFE180-04AN-024A-4	200%	13.5	27.0	6.8	31.8
			300%	10.0	30.0	6.8	35.3	2.1	
HXA142130B	7.4	41.1	MFE180-04AN-024A-4	200%	13.5	27.0	6.8	23.6	2.1
				300%	10.0	30.0	6.8	26.3	2.1
			MFE180-04AN-031A-4	200%	21.0	42.0	6.8	36.0	2.1
				300%	16.0	48.0	6.8	36.0	2.1
HXA142020B	5.2	30.2	MFE180-04AN-016A-4	200%	9.0	18.0	10.0	28.6	2.1
				300%	7.0	21.0	10.0	33.4	2.1
			MFE180-04AN-024A-4	200%	13.5	27.0	10.0	42.9	2.1
				300%	10.0	30.0	10.0	47.7	2.1
HXA141920B	5.5	44	MFE180-04AN-016A-4	200%	9.0	18.0	9.0	28.6	1.9
				300%	7.0	21.0	9.0	33.4	1.9
			MFE180-04AN-024A-4	200%	13.5	27.0	9.0	43.0	1.9
				300%	10.0	30.0	9.0	47.7	1.9
			MFE180-04AN-031A-4	200%	21.0	42.0	9.0	66.8	1.9
				300%	16.0	48.0	9.0	70.0	1.9
HXA185820B	14.0	51.3	MFE180-04AN-031A-4	200%	21.0	42.0	28.0	86.0	5.9
				300%	16.0	48.0	28.0	98.2	5.9
			MFE180-04AN-046A-4	200%	28.0	56.0	28.0	105.0	5.9
				300%	20.0	60.0	28.0	105.0	5.9
HXA185920B	24.5	90.6	MFE180-04AN-060A-4	200%	35.0	70.0	28.0	81.1	5.9
				300%	25.0	75.0	28.0	86.9	5.9
			MFE180-04AN-090A-4	200%	55.0	110.0	28.0	105.0	5.9
				300%	40.0	120.0	28.0	105.0	5.9
HXA185315B	16.0	70.3	MFE180-04AN-046A-4	200%	28.0	56.0	34.0	111.5	5.3
				300%	20.0	60.0	34.0	119.5	5.3
			MFE180-04AN-060A-4	200%	35.0	70.0	34.0	139.4	5.3
				300%	25.0	75.0	34.0	140.0	5.3
HXA186015B	16.5	93	MFE180-04AN-046A-4	200%	28.0	56.0	39.0	126.5	6.1
				300%	20.0	60.0	39.0	135.5	6.1
			MFE180-04AN-060A-4	200%	35.0	70.0	39.0	158.1	6.1
				300%	25.0	75.0	39.0	169.4	6.1
			MFE180-04AN-090A-4	200%	55.0	110.0	39.0	210.0	6.1
				300%	40.0	120.0	39.0	210.0	6.1
HXA186115B	24.5	137.6	MFE180-04AN-060A-4	200%	35.0	70.0	39.0	106.8	6.1
				300%	25.0	75.0	39.0	114.5	6.1
			MFE180-04AN-090A-4	200%	55.0	110.0	39.0	167.9	6.1
				300%	40.0	120.0	39.0	183.1	6.1

# 400 V product package combination

## MotiFlex e180 and HY servo motor

Motor parameters			Drive type and rating				Package rating		
Motor type	Cont. current (A)	Peak current (A)	Drive type	Mode <sup>1)</sup>	Rated Amps (A)	Peak Amps (A)	Cont Torque (N.m)	Peak Torque (N.m)	Rated power (kW)
HYA655030A	4.3	14.7	MFE180-04AN-05A0-4	200%	4.0	8.0	1.5	2.5	0.5
				300%	2.7	8.1	1.0	2.5	0.5
			MFE180-04AN-07A0-4	200%	4.7	9.4	1.6	2.9	0.5
				300%	3.2	9.6	1.2	2.9	0.5
			MFE180-04AN-016A-4	200%	9.0	18.0	1.6	4.5	0.5
				300%	7.0	21.0	1.6	4.5	0.5
HYA101030A	5.6	20	MFE180-04AN-016A-4	200%	9.0	18.0	3.2	8.6	1.0
				300%	7.0	21.0	3.2	9.6	1.0
			MFE180-04AN-024A-4	200%	13.5	27.0	3.2	9.6	1.0
				300%	10.0	30.0	3.2	9.6	1.0
HYA101730A	9.1	36.2	MFE180-04AN-024A-4	200%	13.5	27.0	5.3	12.3	1.7
				300%	10.0	30.0	5.3	13.7	1.7
			MFE180-04AN-031A-4	200%	21.0	42.0	5.3	16.5	1.7
				300%	16.0	48.0	5.3	16.5	1.7
HYA131620B	7	27.8	MFE180-04AN-016A-4	200%	9.0	18.0	7.5	14.6	1.6
				300%	7.0	21.0	7.5	17.0	1.6
			MFE180-04AN-024A-4	200%	13.5	27.0	7.5	21.9	1.6
				300%	10.0	30.0	7.5	22.5	1.6
HYA132820B	10.8	42.4	MFE180-04AN-024A-4	200%	13.5	27.0	13.4	28.7	2.8
				300%	10.0	30.0	12.4	31.8	2.8
			MFE180-04AN-031A-4	200%	21.0	42.0	13.4	44.6	2.8
				300%	16.0	48.0	13.4	45.0	2.8
HYA185020B	15.3	48.8	MFE180-04AN-031A-4	200%	21.0	42.0	24.0	64.6	5.0
				300%	16.0	48.0	24.0	73.8	5.0
			MFE180-04AN-046A-4	200%	28.0	56.0	24.0	75.0	5.0
				300%	20.0	60.0	24.0	75.0	5.0
HYA186520B	20.2	68.5	MFE180-04AN-046A-4	200%	28.0	56.0	31.0	85.8	6.5
				300%	20.0	60.0	30.7	92.0	6.5
			MFE180-04AN-060A-4	200%	35.0	70.0	31.0	105.0	6.5
				300%	25.0	75.0	31.0	105.0	6.5
HYA188020B	24.2	95	MFE180-04AN-060A-4	200%	35.0	70.0	38.5	99.5	8.0
				300%	25.0	75.0	38.5	106.6	8.0
			MFE180-04AN-090A-4	200%	55.0	110.0	38.5	135.0	8.0
				300%	40.0	120.0	38.5	135.0	8.0





—  
For more information and contact details:

[www.abb.com/motors&generators](http://www.abb.com/motors&generators)

**Additional information**

We reserve the right to make technical changes or modify the contents of this document without prior notice. With regard to purchase orders, the agreed particulars shall prevail. ABB AG does not accept any responsibility whatsoever for potential errors or possible lack of information in this document.

We reserve all rights in this document and in the subject matter and illustrations contained therein. Any reproduction, disclosure to third parties or utilization of its contents-in whole or in parts-is forbidden without prior written consent of ABB AG.