

PRODUCT BROCHURE

Quick-Kon[®] automated crimping system for Sta-Kon[®] terminals



Quick-Kon® automated crimping system

Quick-Kon automated crimping system is a left-to-right side feed electric die and tool pack system that installs in several industry-automated wire processing machines.

The terminal-specific tooling, which includes the stock guide assembly, punches and anvil, rear rail, sensor, pressure pad, cutter retainer and crimping tools (collectively referred to as a “tool pack”) can be removed and installed easily in less than 2 minutes. As a result, one Quick-Kon automated crimping system can be used to crimp a large variety of terminals, simply with the purchase of additional tool packs. Significant reductions in tooling costs can be achieved because applicators do not need to be purchased for each terminal.

Unlike traditional applicators that use pneumatic mechanical designs to feed terminals, the Quick-Kon automated crimping system uses a patented feeding method that electronically performs feeding operations pre-termination. The stepper motor-driven pinch rollers engage the carrier strip

and push the terminals into place for crimping. Microprocessor-based electronics, in conjunction with sensors, initiate a feeding cycle on the upward motion of the ram and control the stepper motor to precisely position the next terminal to be crimped.

A feed controller allows the operator to set feeding parameters electronically. As a result of this superior terminal feeding system, tool packs are readily accessible and easy to change out. Set up is quick and easy.

Competitive offering

This is an excellent tool system for larger OEMs and panel builders making thousands of terminal connections who are seeking to increase productivity while reducing changeout time and labor costs.

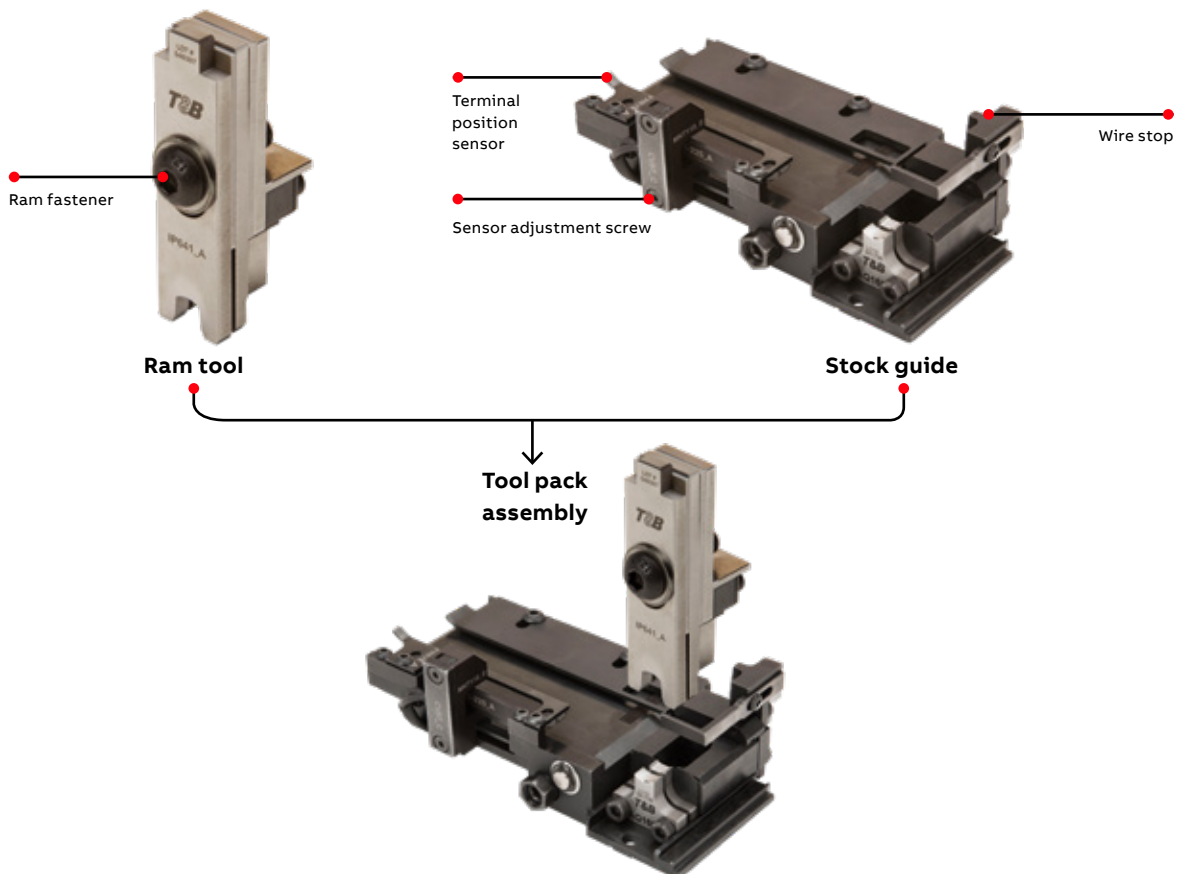

Tool packs



Cat. no.	Disconnect reel		Wire range (AWG)	
TNB177D01	RA-nylon	RA-vinyl	22	18
TNB177D02	RB-nylon	RB-vinyl	16	14
TNB177D03	RC-nylon	RC-vinyl	12	10
Cat. no.	Terminal reel		Wire range (AWG)	
TNB177T01	RA-nylon		22	16
TNB177T02	RB-nylon	RB-vinyl	18	14
TNB177T03	RC-nylon	RC-vinyl	12	10
	RBC-nylon	RBC-vinyl	16	12
TNB177T04	RA-vinyl		22	16
TNB177T05	A-non insulated		22	16

Installation manuals are located on our website at www.tnb.abb.com

Electric die



Cat. no.	Description
TNB170-ELECDIE	Electric die

Tool pack is inserted into the electric die (TNB170-ELECDIE) to create the electric die assembly. Please refer to TNB-ELECDIE manual for proper installation. Installation manuals are located on our website at www.tnb.abb.com

Electric press



Cat. no.	Description
TNB010-PRESS	2.2 Ton 40 mm press

Electric die assembly is placed into the electric press (TNB010-PRESS) to create the electric press assembly. Please refer to TNB010-PRESS manual for proper installation. Installation manuals are located on our website at www.tnb.abb.com

Ordering information

Funnel kit assembly

Cat. no.	
TNB197	Funnel kit assembly

Wire guide kit

Cat. no.	Wire size (AWG)
Left hand assembly wire guide kit	
TNB189-018	22
TNB189-022	20
TNB189-025	18
TNB189-031	16
TNB189-039	14
TNB189-050	12
TNB189-062	10
Cat. no.	Wire size (AWG)
Right hand assembly wire guide kit	
TNB190-018	22
TNB190-022	20
TNB190-025	18
TNB190-031	16
TNB190-039	14
TNB190-050	12
TNB190-062	10

For more information on wire guide kit and funnel kit assembly; please refer to the TNB170-ELECDIE manual located on www.tnb.abb.com

TNB197 — Funnel kit assembly

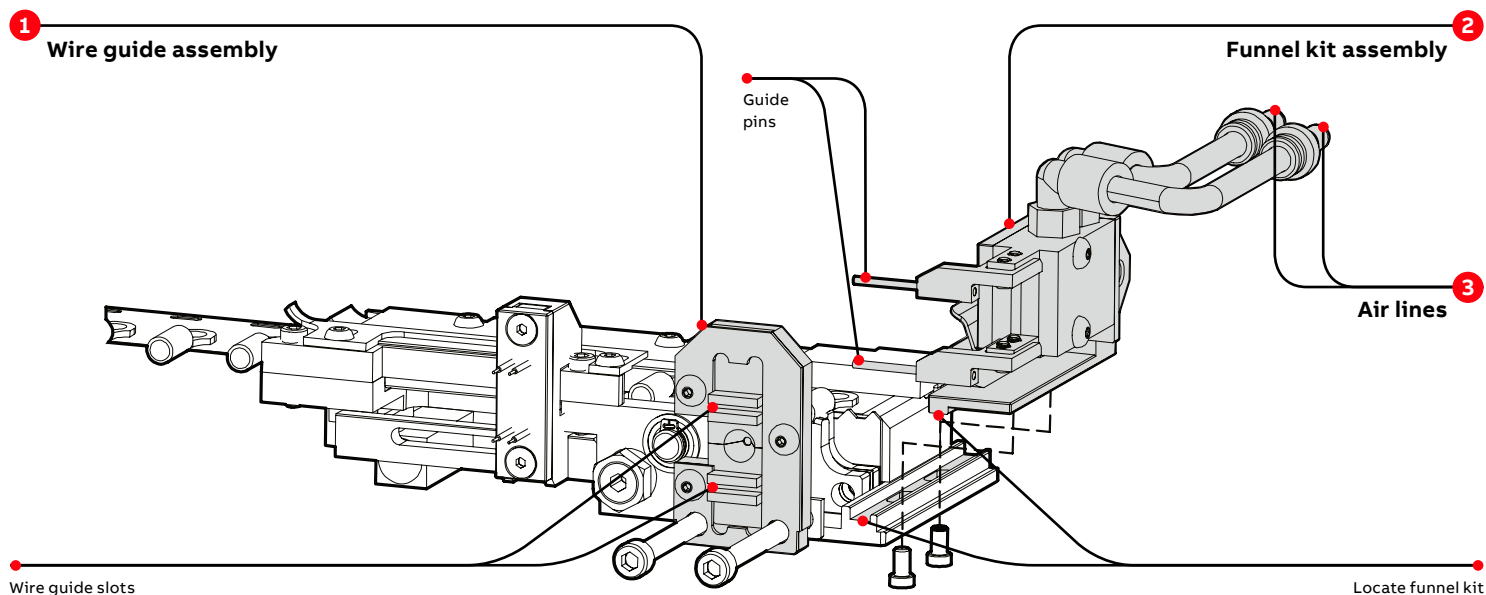

ABB Installation Products Inc.
 Electrification Products Division
 860 Ridge Lake Blvd.
 Memphis, TN 38120

tnb.abb.com

We reserve the right to make technical changes or modify the contents of this document without prior notice. With regard to purchase orders, the agreed particulars shall prevail. ABB Inc. does not accept any responsibility whatsoever for potential errors or possible lack of information in this document.

We reserve all rights in this document and in the subject matter and illustrations contained therein. Any reproduction or utilization of its contents – in whole or in parts – is forbidden without prior written consent of ABB Inc. Copyright© 2019 ABB All rights reserved