

## Model RGMESP for ABB Wall Mounted Surge Protection

ReliaGear® Wall Mounted Surge Protective Devices (SPD)

### Differentiating Technology

The ReliaGear® RGMESP Series offers robust surge protection with an emphasis on performance, safe operation, and user-friendly diagnostics.



SPD, 80 & 100 kA per mode

### Standards

- UL 1449 5th Ed. – Listed, Open Type—Mil-Std-220C
- UL 1283 Listed EMI/RFI Filter—ANSI/NFPA 70 (Art. 242, Formerly 285)
- UL 96A – Meets SPD criteria—ANSI/IEEE C62.45
- cUL Listed to UL 1449 & CSA C22.2—ANSI/IEEE C62.62 & C62.72

ReliaGear® RGMESP Series SPDs are engineered with smart thermal disconnecting technology that safely removes overstressed components before harmful external effects arise. This preventive approach enhances safety and avoids nuisance from OCPD tripping or thermal events.

The core suppression system includes proprietary Metal Oxide Varistors (MOVs) for surge energy diversion and metal film capacitors for filtering low-level transient voltages and electrical noise. The design is UL Listed as an open-type SPD, suitable for field installation or replacement.

The RGMESP series includes LED status indication. A green LED indicates proper protection on a mode. If an LED extinguishes, the product has lost protection and should be replaced. To support remote monitoring, the RGMESP also includes a Form C dry contact relay via a 3-wire pigtail.



# Electrical Specifications

**Surge Current Rating** – (there is no standardized test from UL, IEEE or IEC).

Values in the table below are **per mode**.

Model	L-N	L-G	N-G	L-L
RGMESPXXX08T2	80 kA	80 kA	80 kA	80 kA
RGMESPXXX10T	100 kA	100 kA	100 kA	100 kA

Nominal Discharge Current (I<sub>n</sub>) 20kA all Models (UL 1449 Sec. 41.7; UL 96A Sec. 13; IEC 61643 Class II.)

Operating Frequency 50 Hz – 60 Hz

Modes of Protection L-N, L-G, N-G, L-L

Short Circuit Current Rating (SCCR) – 200 kA for all models

VPR & MCOV See Table Below

## MCOV Table

Model	Voltage	L-L	L-N	L-G	N-G	H-L	H-N	H-G
RGMESP120SXXXX	120S	300	150	150	150			
RGMESP120YXXXX	120Y	300	150	150	150			
RGMESP127YXXXX	127Y	300	150	150	150			
RGMESP240DXXXX	240D	540		270				
RGMESP240HXXXX	240H	300	150	150	150	420	270	270
RGMESP240YXXXX	240Y	640	320	320	320			
RGMESP277YXXXX	277Y	640	320	320	320			
RGMESP480DXXXX	480D	1100		550				

## VPR Table

Model	Voltage	L-L	L-N	L-G	N-G	H-L	H-N	H-G
RGMESP120SXXXX	120S	1200	700	700	700			
RGMESP120YXXXX	120Y	1000	700	700	700			
RGMESP127YXXXX	127Y	1000	700	700	700			
RGMESP240DXXXX	240D	1500		900				
RGMESP240HXXXX	240H	1200	700	700	700	1200	900	900
RGMESP240YXXXX	240Y	1800	1200	1200	1000			
RGMESP277YXXXX	277Y	1800	1200	1200	1000			
RGMESP480DXXXX	480D	3000		1800				

**EMI/RFI Noise Attenuation** (UL 1283 listed filter; UL Type 2 SPD Only).

**Mil-Std-220C – US Dept of Defense Std for Method of Insertion Loss Measurement.**

In a typical electrical system, frequencies above 30 MHz are radiated as opposed to conducted electrical noise; any measurement values above 30 MHz are considered irrelevant and should not be considered for specifying SPD filtering capability.

The overall frequency attenuation for all ReliaGear® SPD products is -3dB between 1 kHz and 30 MHz with the maximum attenuation at -61dB at 100.2 kHz.

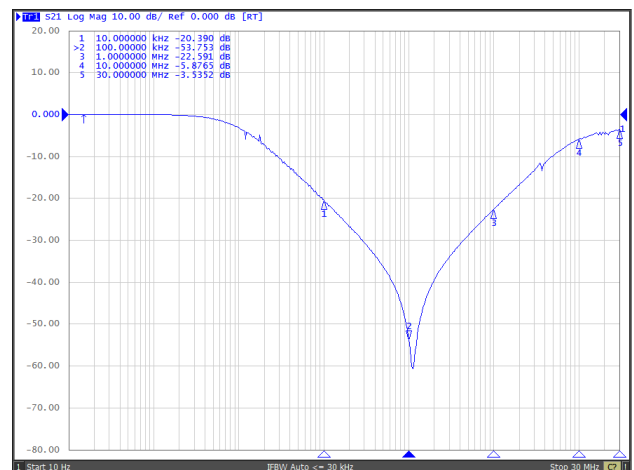



# Electrical Specifications

---

## Fusing

---

All metal oxide varistors (MOVs) are thermally fused, providing event-free disconnection of the MOV from the electrical system upon the component's end of life. SPD status indication circuits (LEDs, Dry (volt free) relay contacts, and Audible Alarms depending on features) give local and if installed remote status indication.

---

## SPD location / Primary Overcurrent Protection

---

Per the National Electrical Code (NEC Article 242, Formerly 285), Type 2 SPDs are allowed to be placed on the load side of the main service breaker/fuse. A dedicated circuit breaker is not required for RG Series models. However, a 30 A rated breaker is recommended to serve as a local means of disconnect should the SPD require servicing or replacement.

---

## SPD Status Monitoring

- Green LED per phase showing power applied and complete operational status of the SPD.
- Advanced Thermally Stacked MOV(s)
- Dry Contacts: Remote dry (volt-free) relay contacts rated at (<2 A, 250Vac / 220Vdc), 1 Form C (SPDT) changes state upon any internal disconnect operating indicating to a customer installed remote indication circuit that the SPD must be replaced.
  - Normally Open / Normally Closed
  - Normally Open = Open during normal operation
  - Normally Closed = Closed during normal operation
- Should any one phase be lost besides other electrical anomalies and system issues, the SPD status indicators may change state providing false indication of the SPD end of life. Once all the phases of the electrical system are restored, and if the SPD is not damaged, the status indicators should reset automatically.

---

## Mechanical/Environmental

---

Operating Temperatures	-40°F (-40°C) to +149°F (+65°C)
Altitude	< 13,000 ft (datasheet value based on C&C calculations)
Surface Temperature	Less than 131°F (55°C)
Humidity	0 - 95% RH
Noise	No Audible Noise
NEMA/UL50 Enclosure	NEMA 4/ Type 4
SPD Enclosure Material	Polymer, UL 94 5VA polycarbonate, black
Weight	5.1lb (Approx.)

---

## Connections

Remote contact wire size	#22 [.08mm <sup>2</sup> ]
Phase Connection Type	Wire Leads (10 AWG)
Neutral and Ground Termination Type	Wire Leads (10 AWG)

---

# Product Specifications

## Dimensions

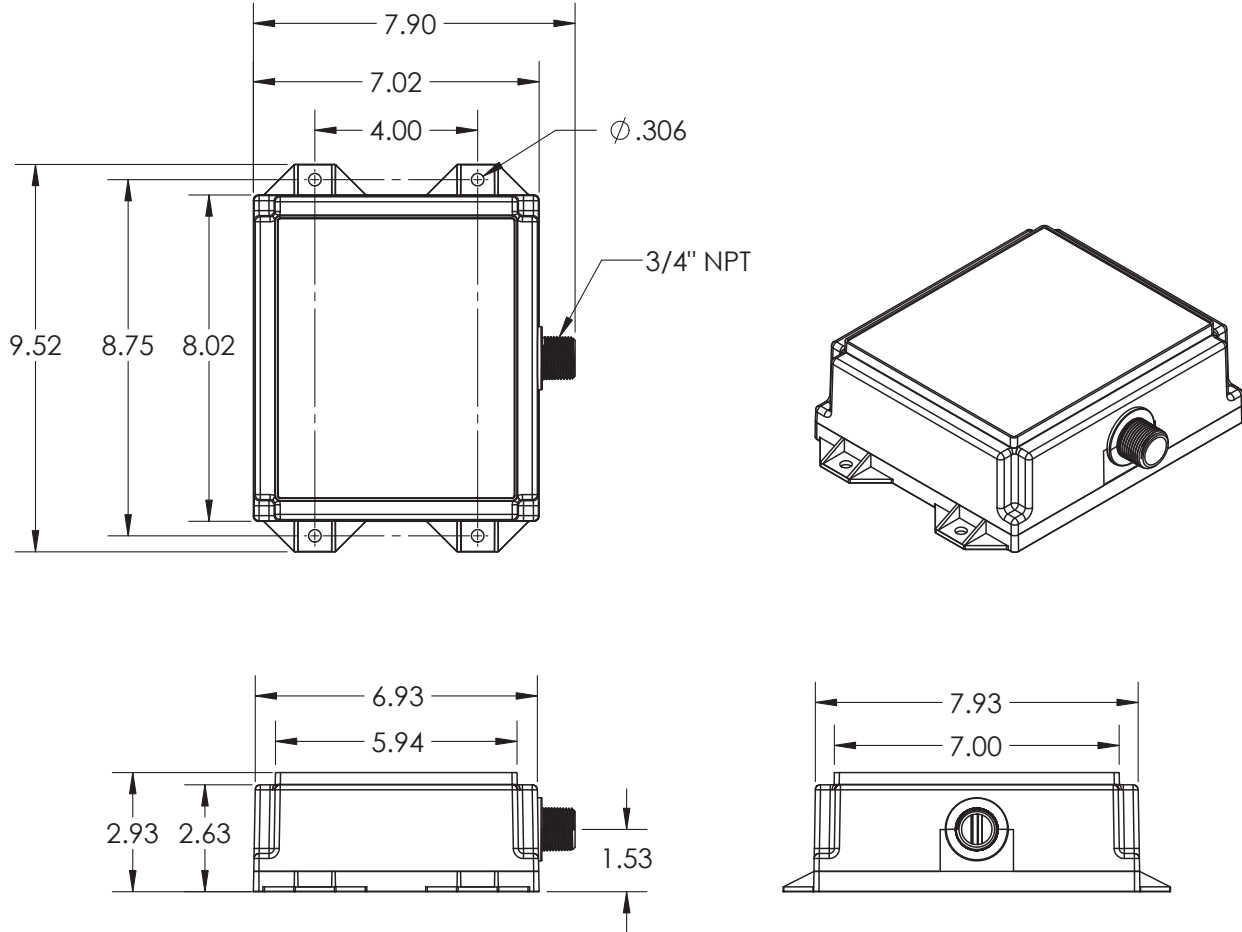

## SPD Part Number Configuration

\*For a full list of orderable products please visit this [resource](#)

**RGMESP**

**120S**

**10**

**T2**

Surge Protection Devices	
Code	
RGMESP	RG Series SPD

Nominal Voltage (Volt RMS)	
Code	(per mode)
120S	120/240 Split
120Y	120Y/208
220Y	127Y/220
240D	240 Delta
240H	120/240 Delta HL
240Y	240Y/415
277Y	277Y/480
480D	480 Delta

Max Surge Capacity	
Code	(per mode)
08	80kA
10	100kA

Type	
Code	
T2	UL Type 2



# Troubleshooting

There are no serviceable parts inside the SPD. Should SPD indicator LEDs change to RED during its lifetime, the SPD unit will have to be replaced. Please see the instruction manual for further replacement instructions.

## RGMESP Series Truth Table

Operational "OK"	Audible Alarm: NONE
	LEDs: Green—ON
	Red Service Light: OFF
	Dry Contact: NORMAL
MOV Disconnect	Green LED will be extinguished
	Dry Contact: Triggered

## Warranty

The RGMESP series Surge Protection Device carries a standard 5-year limited warranty.

ABB standard Ts&Cs (12/18)



**ABB Inc.**  
305 Gregson Drive  
Cary, NC 27511



We reserve the right to make technical changes or modify the contents of this document without prior notice. With regard to purchase orders, the agreed particulars shall prevail. ABB Inc. does not accept any responsibility whatsoever for potential errors or possible lack of information in this document.

We reserve all rights in this document and in the subject matter and illustrations contained therein. Any reproduction, disclosure to third parties or utilization of its contents – in whole or in parts – is forbidden without prior written consent of ABB Inc. Copyright © 2026 ABB