

# Bus couplers InLine II special variants

Doc ID, 1SEC312022B0203. November 2016,

## Bus Couplers

A range of Bus couplers is developed for the InLine II product range. The Bus coupler is a product for feeding energy between 2 sets of busbars, ensuring safe sectioning of busbars. Bus coupler can be a fuse switch disconnecter, a switch disconnecter or a fuse base.

ZUBM3-BC, ZLBM2-BC, ZLBM3-BC can be easily made as "Left version" by customer just by turning base.

BZH Switch disconnectors come as corrosion free version.

## Safety and protection

The front windows can be slid up to give access for safe voltage measurement at the fuse contacts. There is also a separate position for safe and efficient replacement of fuses. The cover can also be padlocked to avoid unadmitted operation.

## Easy to install

All the bus couplers are designed for feeding from the right side. For ZUBM and ZLBM types, it is easy to change the connection from right to left just by turning the base around.

## Continuous operation

With InLine II bus couplers, continuity of operation is ensured by ensuring easy sectionalizing of busbars.



ZUBM3-BC



ZLBM2-BC



ZLBM3-BC



BZH1000-1P-BC,  
BZH1250-1P-BC



BZH1600-1P-BC,  
BZH2000-1P-BC

## Bus couplers ZUBM, ZLBM and BZH

Description	Type	Order Code	Ie (A)	Weight, Kg
Connection from left side possible by turning the base	ZUBM3-BC-Right	1SEP622026R0001	630	2.20
Connection from left side possible by turning the base	ZLBM2-3P-BC-Right	1SEP622028R0001	400	3.35
Connection from left side possible by turning the base	ZLBM3-3P-BC-Right	1SEP622030R0001	630	3.65
Corrossion free version	BZH1000-1P-BC-Right-STS	1SEP622032R0001	1000	5.75
Corrossion free version	BZH1250-1P-BC-Right-STS	1SEP622035R0001	1250	5.75
Corrossion free version	BZH1600-1P-BC-Right-STS	1SEP622033R0001	1600	11.85
Corrossion free version	BZH2000-1P-BC-Right-STS	1SEP622034R0001	2000	11.85

# Technical data

## Bus couplers

Type tested according to EN/IEC 60947-3

		ZLBM2-BC	ZLBM3-BC	ZUBM3-BC	BZH1000A-BC	BZH1250A-BC	BZH1600A-BC	BZH2000A-BC
<b>Fuse links according to EN/IEC 60269-2</b>	<b>Size</b>	<b>NH2</b>	<b>NH3</b>	<b>NH3</b>	<b>Fitted solid link<sup>1)</sup></b>	<b>Fitted solid link<sup>1)</sup></b>	<b>Fitted solid link<sup>1)</sup></b>	<b>Fitted solid link<sup>1)</sup></b>
Rated operational current I <sub>e</sub>	A	400	630	630	1000	1250	1600	2000
Conventional free air thermal current I <sub>th</sub>	A	400	630	630	1000	1250	1600	2000
Rated operational voltage U <sub>e</sub>	V	690	690	690	690	690	690	690
Rated insulated voltage U <sub>i</sub>	V	1000	1000	1000	1000	1000	1000	1000
Rated impulse withstand voltage U <sub>imp</sub>	kV	8	8	8	8	8	8	8
Fuse protected short circuit withstand current	kA	100	100	100	-	-	-	-
Fuse protected short circuit making current	kA	100	100	-	-	-	-	-
Short-time withstand current – 1sec(rms)	kA	-	-	-	15	15	30	30
Short-circuit making capacity (peak)	kA	-	-	-	15	15	30	30
Utilization category – EN/IEC 60947-3	-	AC22B	AC22B	AC20B	AC22B	AC22B	AC21B	AC21B
Mechanical durability	operations	800	800	1000	500	500	500	500
Electrical durability	operations	200	200	-	100	100	100	100
Degree of protection IEC 60529	Close	IP30	IP30	IP20	IP30	IP30	IP30	IP30
	Open	IP20	IP20		IP20	IP20	IP20	IP20
Pollution degree	-	3	3	3	3	3	3	3
Overtoltage category – IEC 60947-1	-	IV	IV	IV	IV	IV	IV	IV
Rated Frequency	Hz	50/60	50/60	50/60	50/60	50/60	50/60	50/60
Max. allowed power dissipation of NH-Fuse	W	34	48	48	-	-	-	-
Universal terminal bolt size	-	M12	M12	M12	M12	M12	M12	M12
Terminal tightening torque	NM	25	25	25	35	35	35	35

Note: <sup>1)</sup> The solid links are included in the product.

# Dimensional drawings Bus couplers

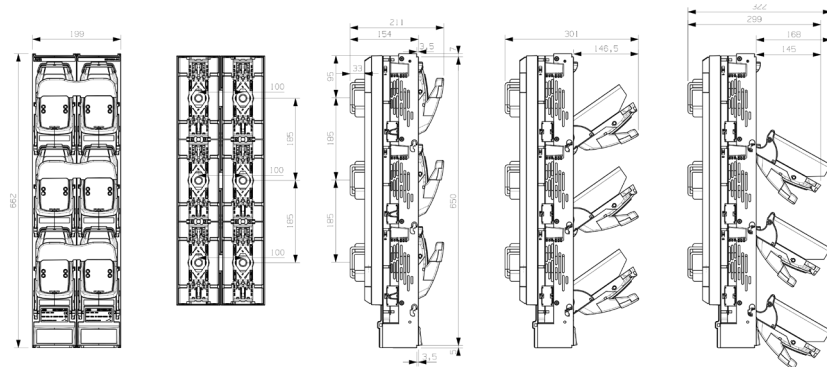

**BZH1600-1P-BC, BZH2000-1P-BC**

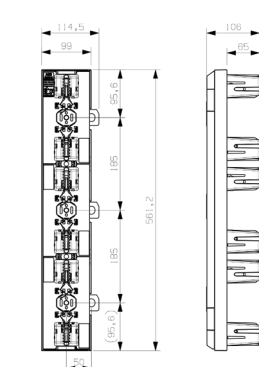

**ZUBM3-BC**

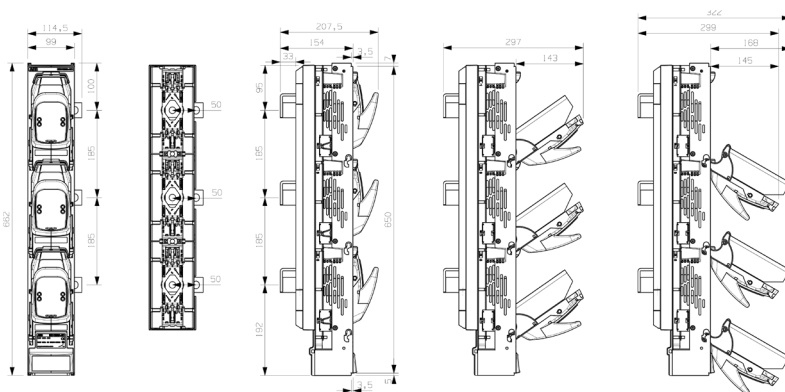

**BZH1000-1P-BC, BZH1250-1P-BC**

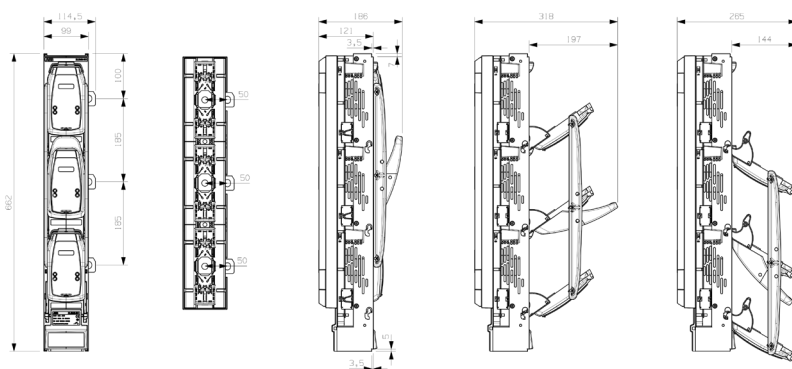

**ZLBM2-BC, ZLBM3-BC**

For more information please contact:

**ABB Protection and Connection**

P.O. Box 622

FI-65101 Vaasa, Finland

<http://new.abb.com>

<http://new.abb.com/low-voltage/products/fusegear>