

NOTES:

1. **WARNING:** This drawing does not illustrate the installation methods required for hazardous locations. Prior to any installation in a Classified Hazardous Location, verify installation methods by the Control Drawing referenced on the product's name tag and national and local codes.
2. To access the XMV termination board, remove the enclosure rear cover.
3. Maximum accumulated length for the RS-485 buss is 4000 feet.

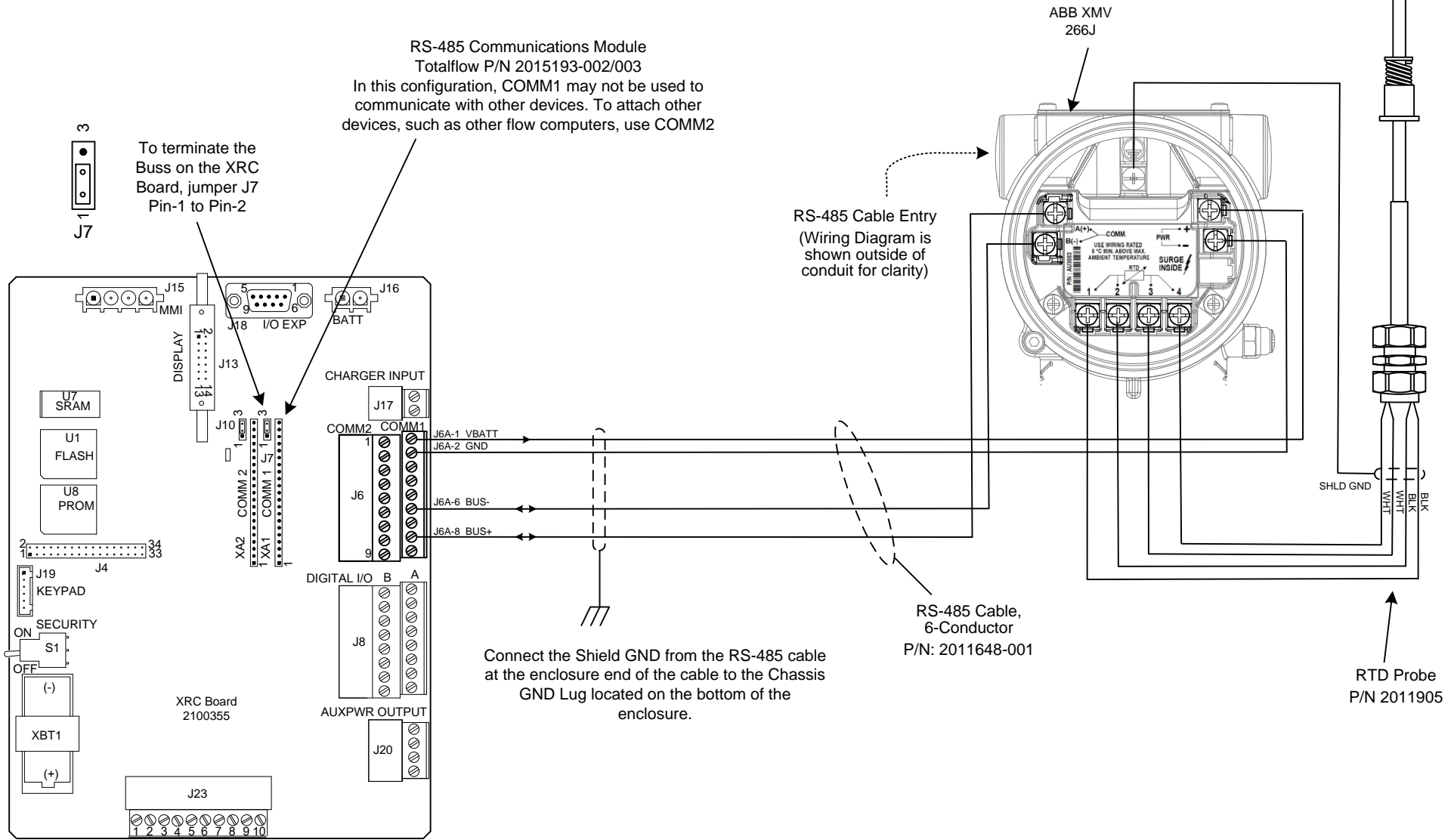

ABB	TOTALFLOW Products	ACTION	DOC TYPE	TITLE	DWG NO.	REV	SHEET
		D35632	UD	XRC G3 (2100355 BOARD) COMM1 (RS-485) TO ABB 266J W/RTD	2105378	AA	1 OF 1