

This webinar brought to you by the Relion® product family Advanced protection and control IEDs from ABB

Relion. Thinking beyond the box.

Designed to seamlessly consolidate functions, Relion relays are smarter, more flexible and more adaptable. Easy to integrate and with an extensive function library, the Relion family of protection and control delivers advanced functionality and improved performance.



ABB Protective Relay School webinar series

Disclaimer

ABB is pleased to provide you with technical information regarding protective relays. The material included is not intended to be a complete presentation of all potential problems and solutions related to this topic. The content is generic and may not be applicable for circumstances or equipment at any specific facility. By participating in ABB's web-based Protective Relay School, you agree that ABB is providing this information to you on an informational basis only and makes no warranties, representations or guarantees as to the efficacy or commercial utility of the information for any specific application or purpose, and ABB is not responsible for any action taken in reliance on the information contained herein. ABB consultants and service representatives are available to study specific operations and make recommendations on improving safety, efficiency and profitability. Contact an ABB sales representative for further information.



ABB Protective Relay School Webinar Series – September 13, 2012

Transformer protection fundamentals

Mike Kockott

September 24, 2013

Presenter



Mike Kockott

Mike is a Senior Engineer, Product Specialist for the Relion family 670 and 650 product series. He is located in Raleigh, North Carolina. Mike has been part of the NAM SA Products team for 9 months. Prior to this he worked as a Senior Applications Specialist / Senior Regional Technical Manager for 12 years at the SA Product factory in Västerås, Sweden.

Prior to joining ABB SAP in Sweden in 2000, Mike was Chief Consultant, Protection (Transmission) at Eskom (national power utility, South Africa). Mike joined Eskom as a training engineer in 1983.

Mike graduated from the University of Cape Town with BSc (electrical engineering) degree (with honors) in 1980.

Learning objectives

- Transformer construction and fundamentals
- 3 Phase Connections and vector group
- Transformer Faults
- Protection of transformers (micro processor multifunction)
 - Differential
 - Phase
 - Conventional, enhancements (turn to turn)
 - Inrush and Over excitation
 - REF
 - Over current

Fundamentals of transformer protection

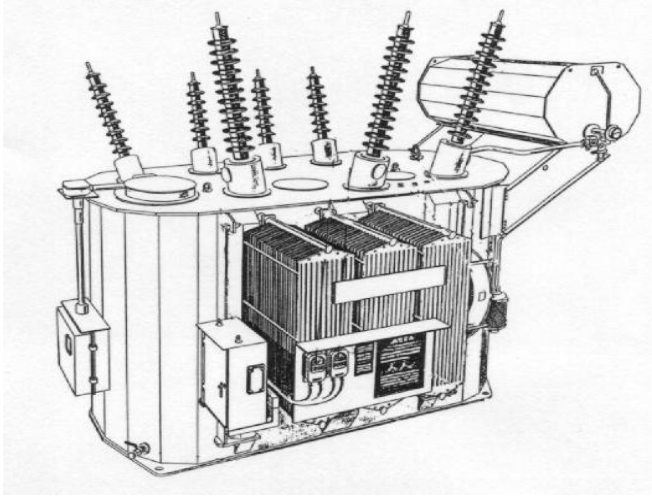

- Important element in the power system
- Interconnection link between two different voltage levels
- Many sizes and types of power transformers
 - Step up
 - Step down
 - Autotransformer
 - Grounding
- Fuses may provide adequate protection for small distribution transformers
- The repair time may be long
- Transformer faults may cause substantial losses

Transformer model

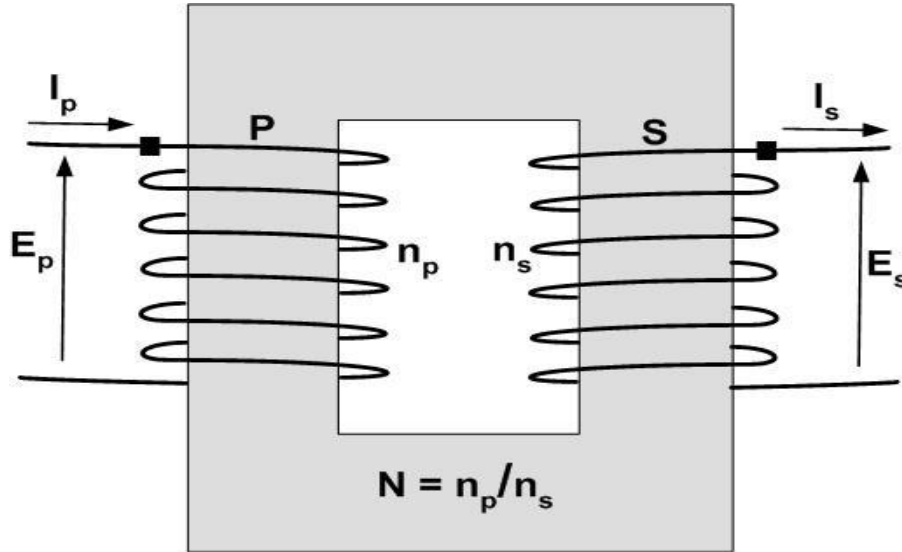

Z_p = Winding 1 resistance + leakage inductance

Z_s = Winding 2 resistance + leakage inductance

$I_h + I_m$ = core + magnetizing losses

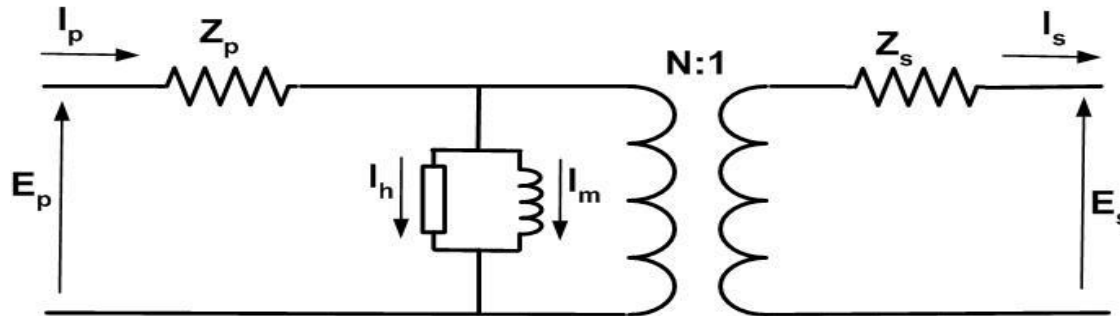

Power transformer

1. HV side bushings
 2. LV side bushings
 3. Load tap changer
 4. Load tap changer operating device
 5. Control panel
 6. Oil thermometer
 7. Gas relay
 8. Radiators
 9. Oil conservator
- N. Neutral bushings

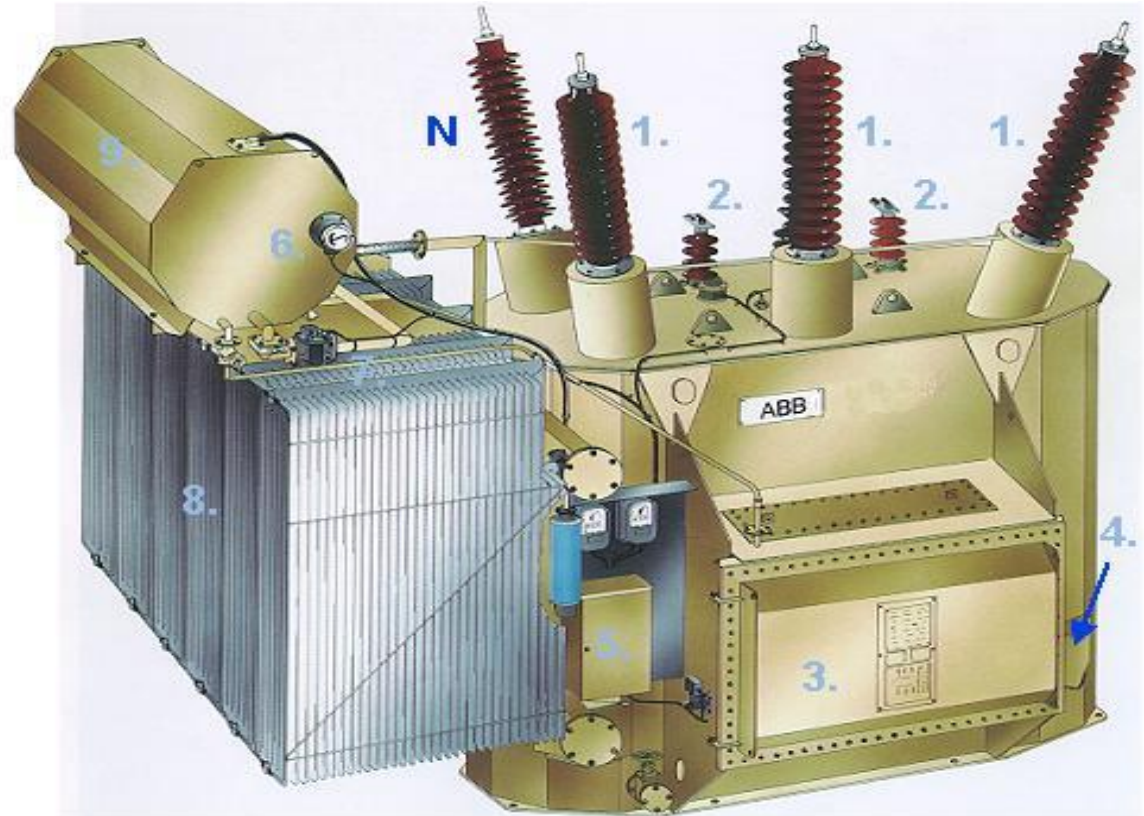

Transformer windings

Winding cutting

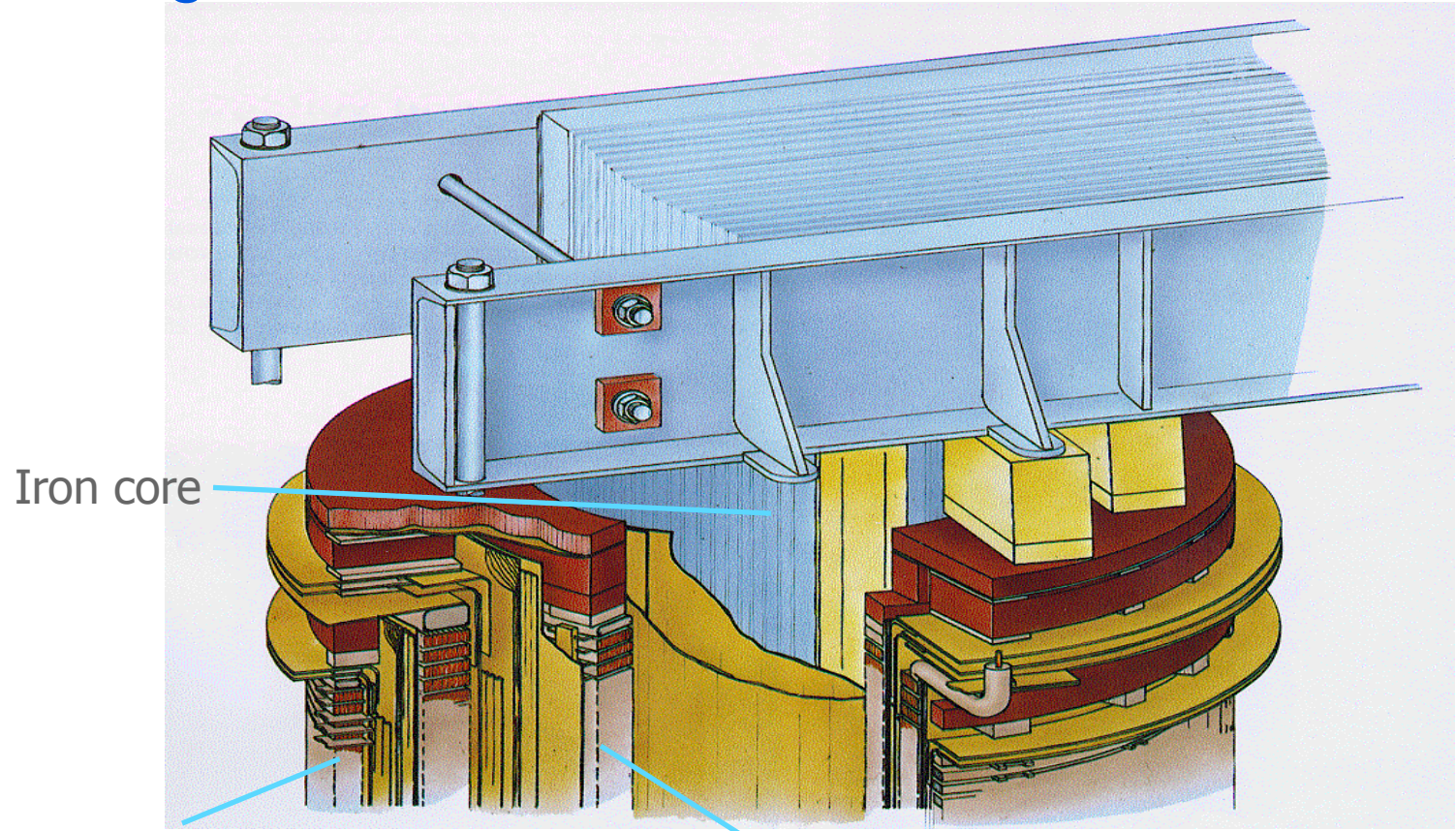

HV voltage winding

LV voltage winding

Three-phase transformer

Considerations for three-phase transformers

- Winding connections
- Number of windings

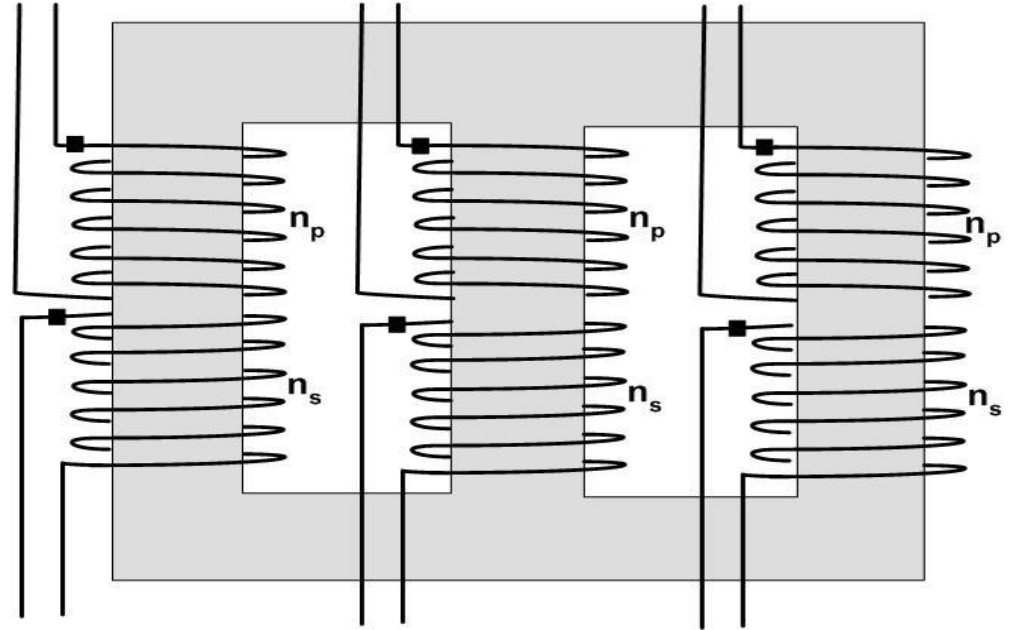

Different winding arrangements

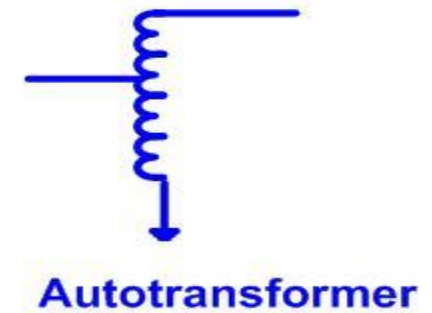
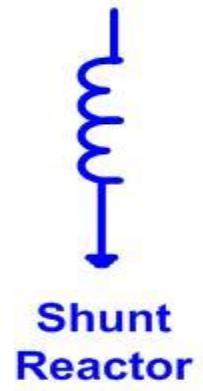

Basic three-phase transformer

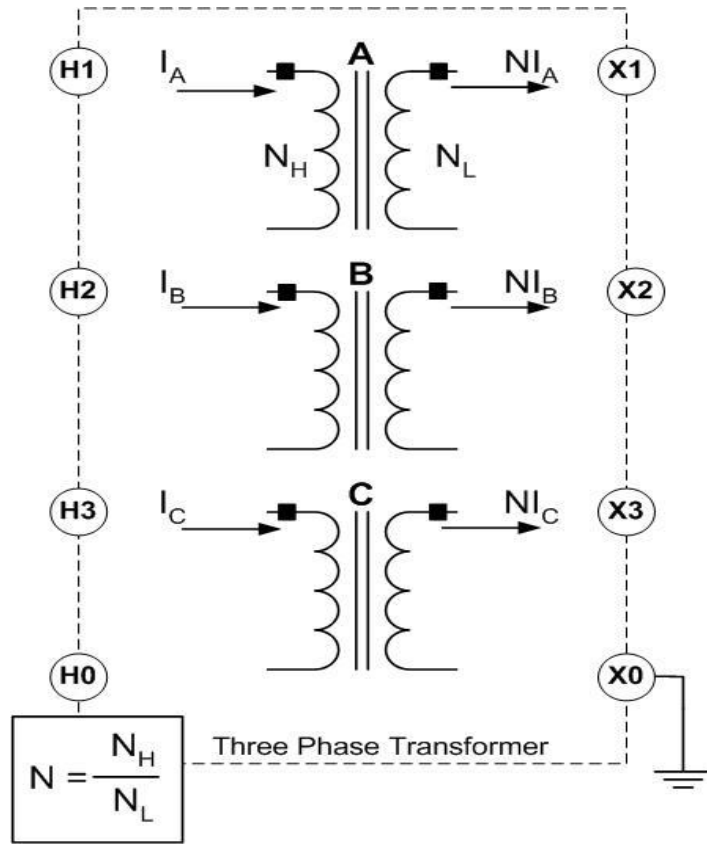

- High voltage bushings
 - H1, H2, H3 => system A, B, C
 - H0 if neutral provided
- Low voltage bushings
 - X1, X2, X3 => system A, B, C
 - X0 if neutral provided
- Tertiary
 - Third winding
 - Y1, Y2, Y3 => system A, B, C

ANSI Standard - transformer connections

High voltage reference is in phase with low voltage reference

High voltage reference leads the low voltage reference by 30°

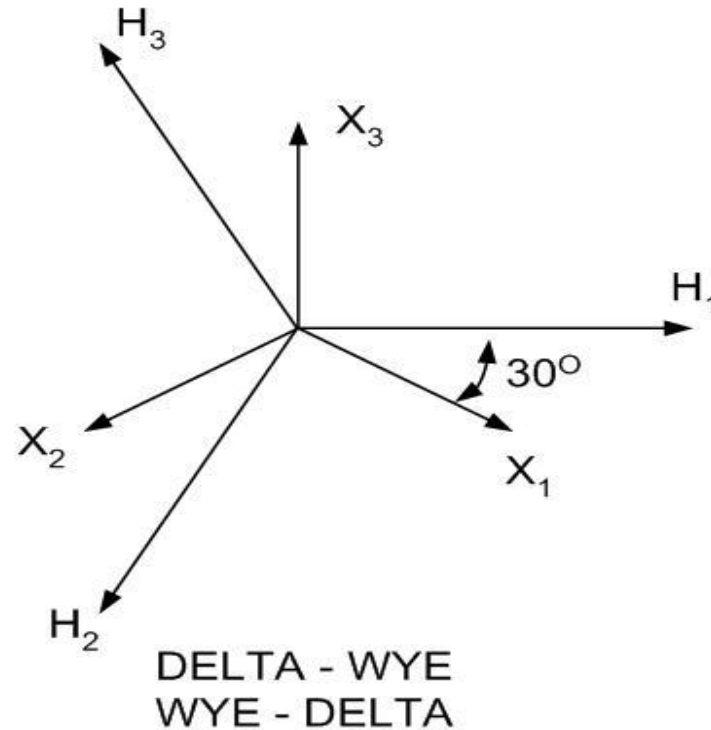
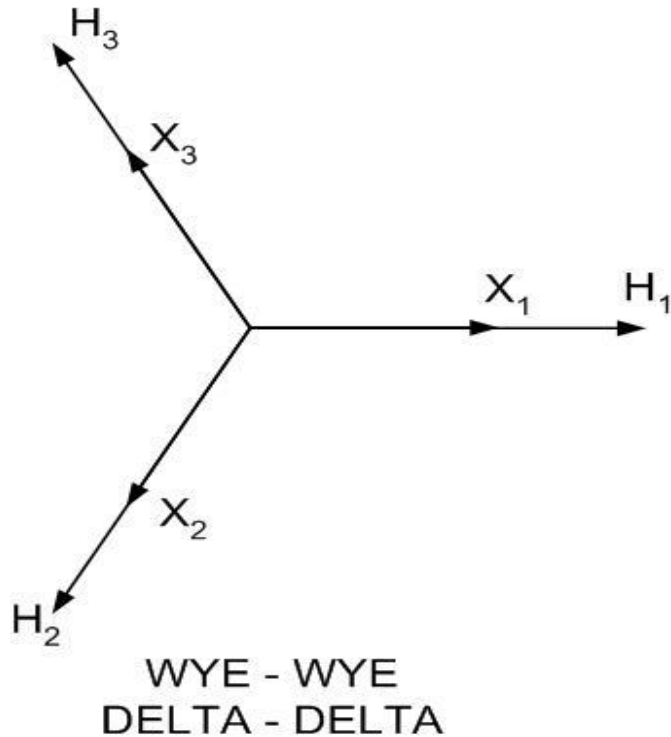

Wye-Wye connected transformer

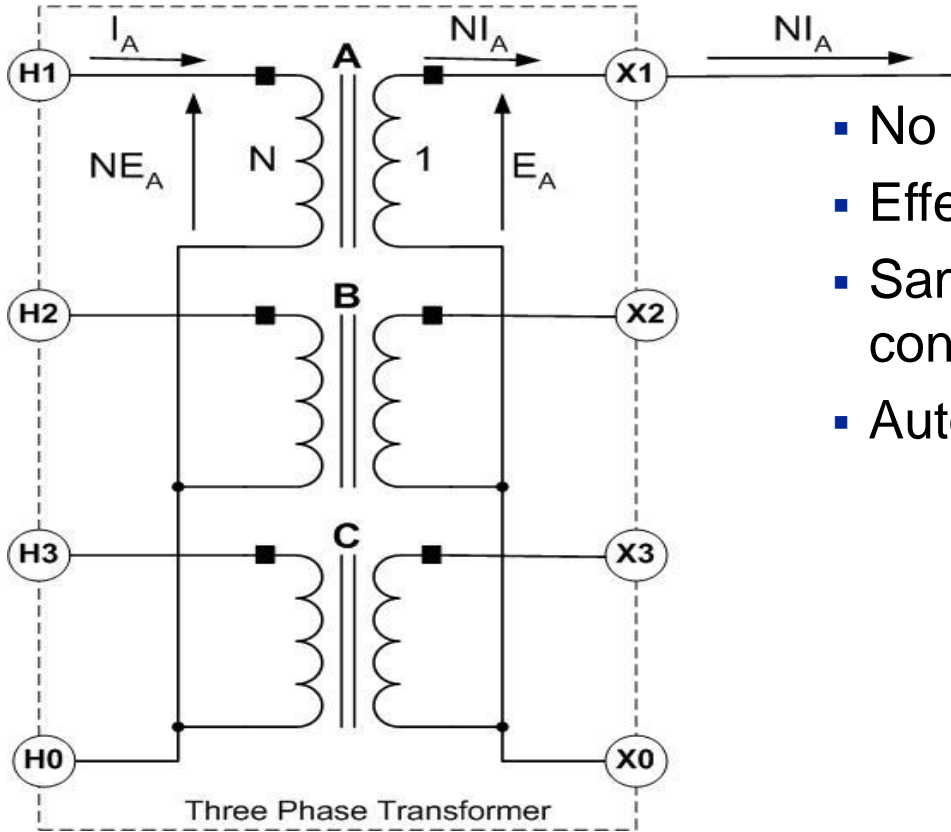

- No phase shift
- Effective turns ratio = N
- Same applies for delta - delta connection
- Auto-transformers

Wye-Delta connected transformer

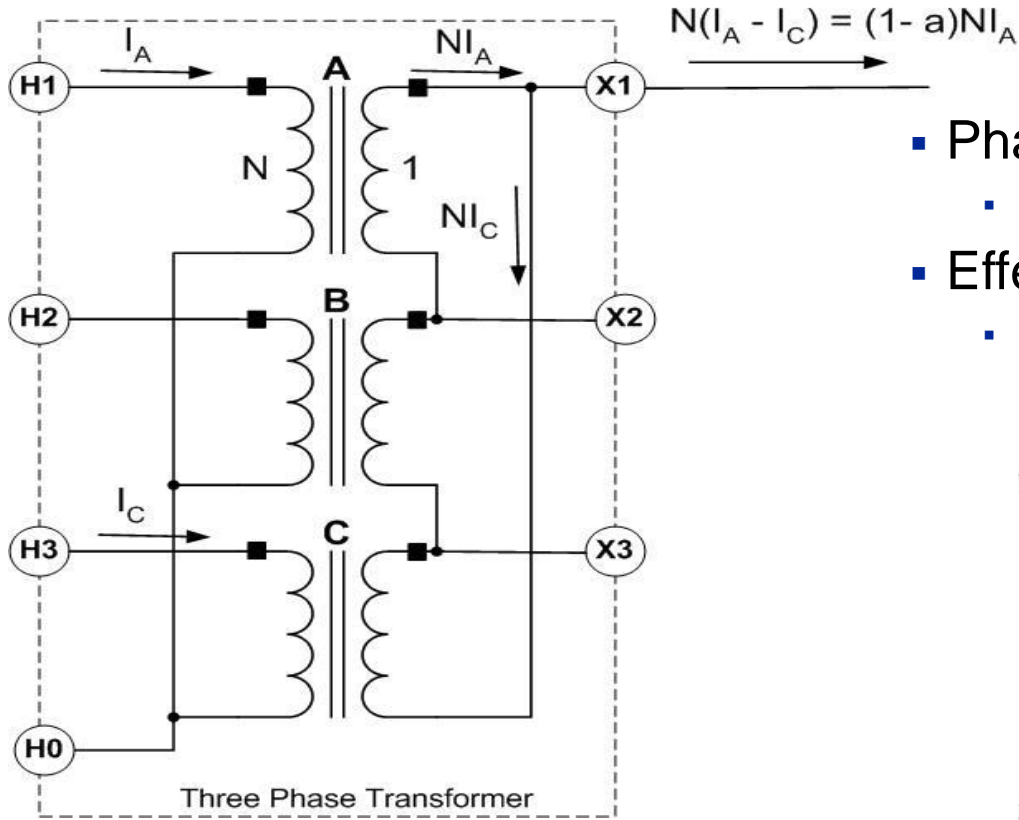

- Phase shift
 - H1 leads X1 by 30°
- Effective turns ratio
 - $n = N\sqrt{3}$

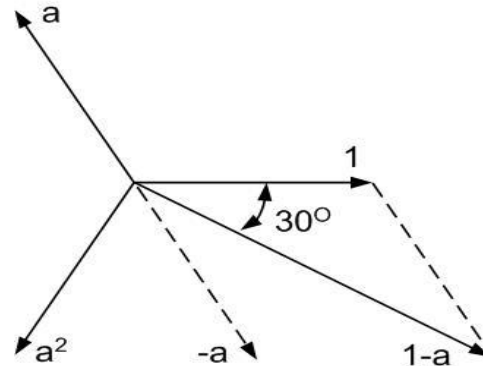

Delta-wye connected transformer

- Phase shift
 - H1 leads X1 by 30°
- Effective turns ratio
 - $n = \frac{N}{\sqrt{3}}$

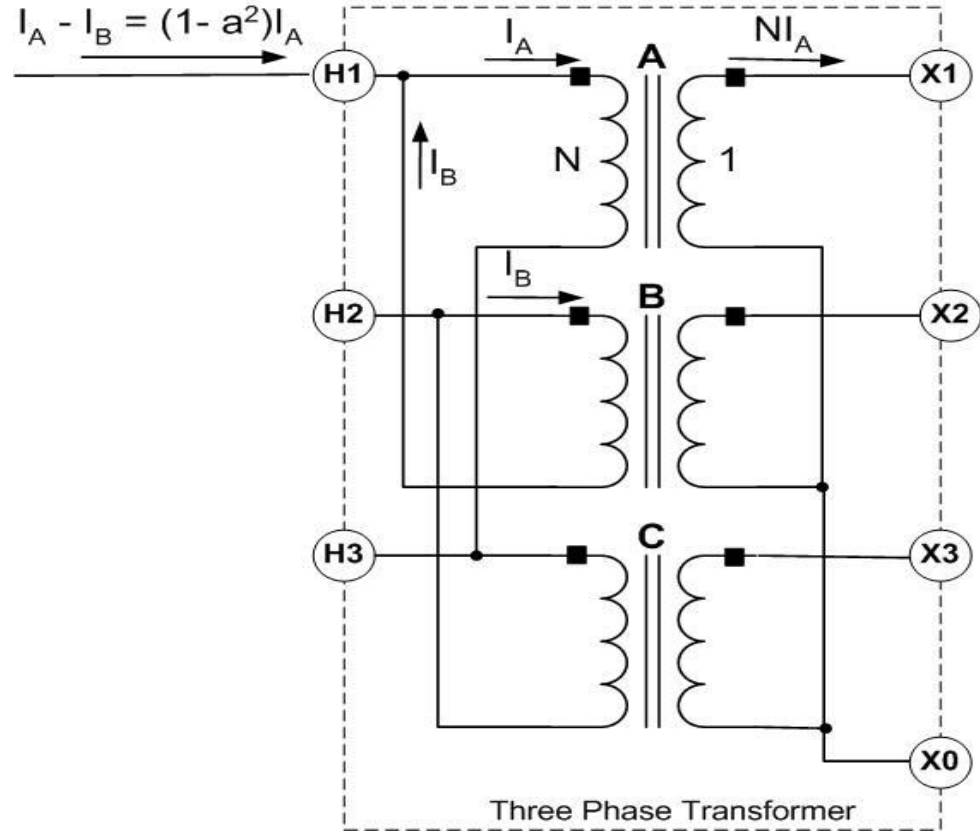
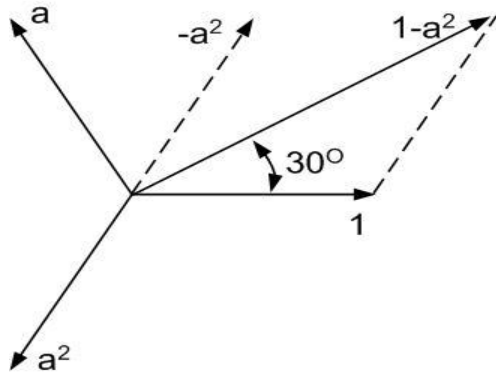

Wye-Delta ANSI standard connections

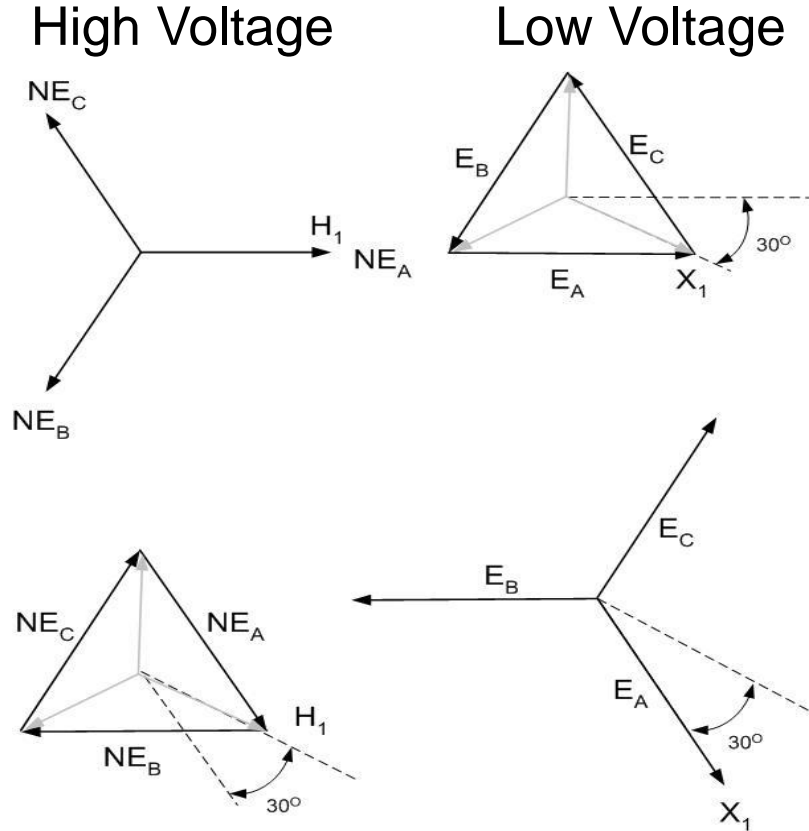

- High voltage reference phase voltage leads the low voltage reference phase voltage by 30°
 - Delta-wye
 - Wye-delta

Vector group – clock system

- Clock system easily documents the phase shift present on a particular transformer
- 12 o'clock position is assumed by first letter (HV)
- Other winding's phase shift is based on clock position

YNd1

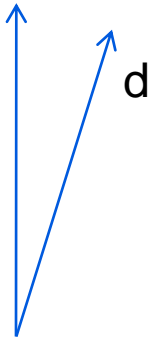

Dyn1

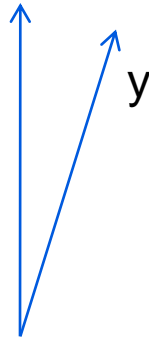

YNyn0d11

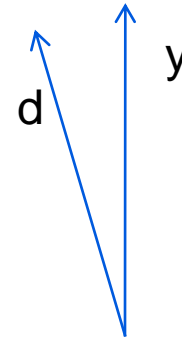

Transformer faults

- Winding failures
 - turn-to-turn insulation failure
 - moisture
 - deterioration
 - phase-to-phase and ground faults
 - external faults (producing insulation failure).....
- Tap changer failures
 - mechanical
 - electrical
 - short circuit
 - oil leak
 - overheating.....

Transformer faults

- Bushing failures
 - aging, contamination, and cracking
 - flashover due to animals
 - moisture
 - low oil
- Core failures
 - Core insulation failure
 - ground strap burned away
 - loose clamps, bolts, wedges...

Transformer faults

- Miscellaneous failures
 - bushing CT failure
 - metal particles in oil
 - damage in shipment
 - external faults
 - poor tank weld
 - overvoltages
 - overloads....

Typical causes of transformer failure

Cause of transformer failures	%
Winding failure	55
Tap changer failures	21
Bushing failures	10
Terminal board failures	6
Core failures	2
Miscellaneous failures	6
All causes	100

*IEEE Guide

Power transformer protection

- Should trip during short-circuit and earth-fault
 - Inside of the power transformer tank
 - In the transformer bay
 - At an external fault, as back-up protection
- Should alarm or trip during abnormal conditions
 - Overload
 - Overvoltage
 - Reduced system voltage
 - Over excitation

Detection of transformer internal faults

- Phase-phase fault
 - Transformer differential protection
 - Buchholz relay
 - Overpressure device (sudden pressure relay)
 - Underimpedance/distance protection
 - Overcurrent protection (non directional, directional)
 - HV fuses
- Ground-fault, low impedance grounding
 - Restricted ground-fault protection
 - Transformer differential protection
 - Buchholz relay
 - Underimpedance/distance protection
 - Overcurrent or ground-fault protection (non directional, directional)
 - HV fuses

Detection of transformer internal faults

- Ground-fault, high impedance grounding
 - Restricted ground-fault protection
 - Sensitive ground-fault current protection
 - Neutral (residual) overvoltage protection
 - Buchholz gas alarm
- Turn-to-turn fault
 - Buchholz alarm
 - Transformer differential protection
- HV to LV winding flash-over
 - Transformer differential protection
 - Buchholz relay
 - Overpressure device (sudden pressure relay)

Differential protection

Typical transformer phase differential configuration

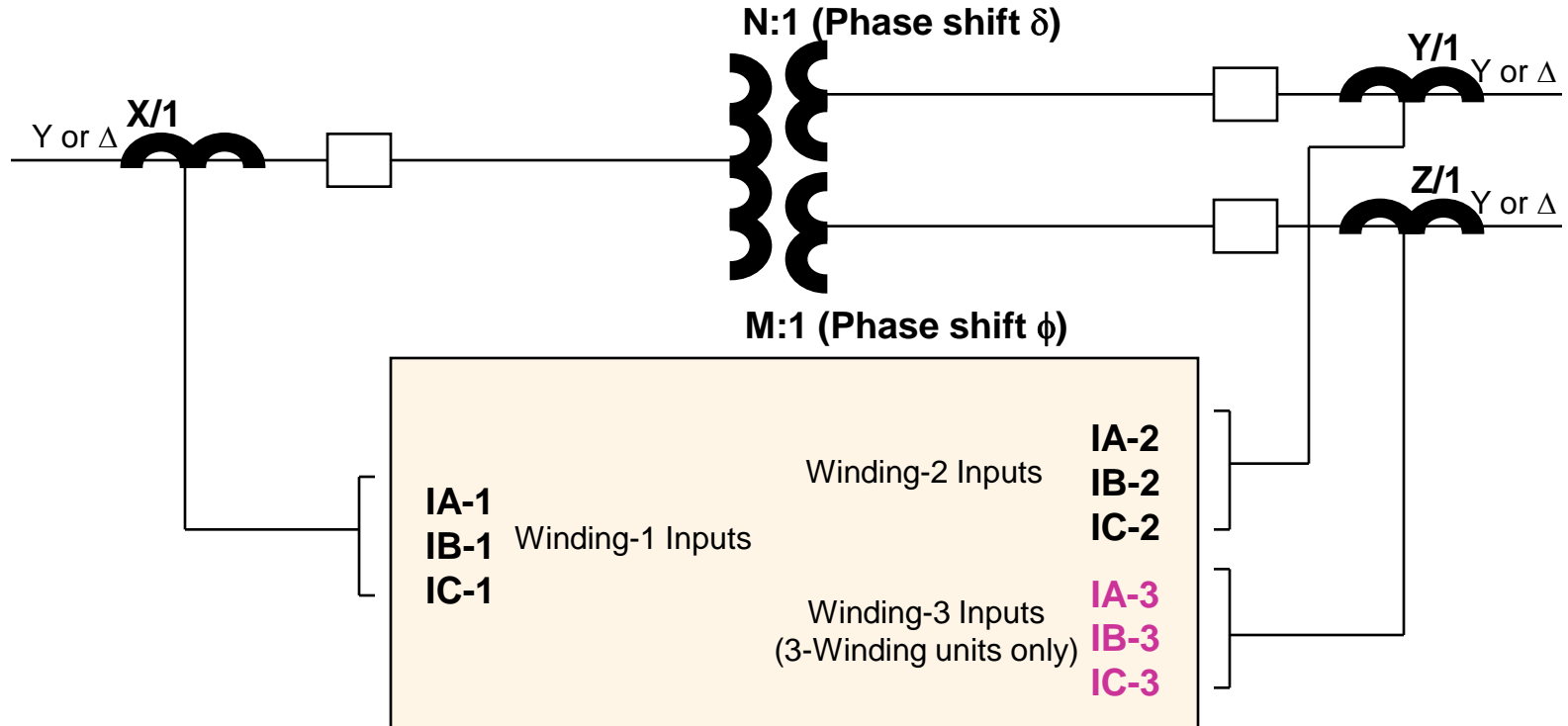

Differential protection

Zone of protection defined by current transformers (CT's)

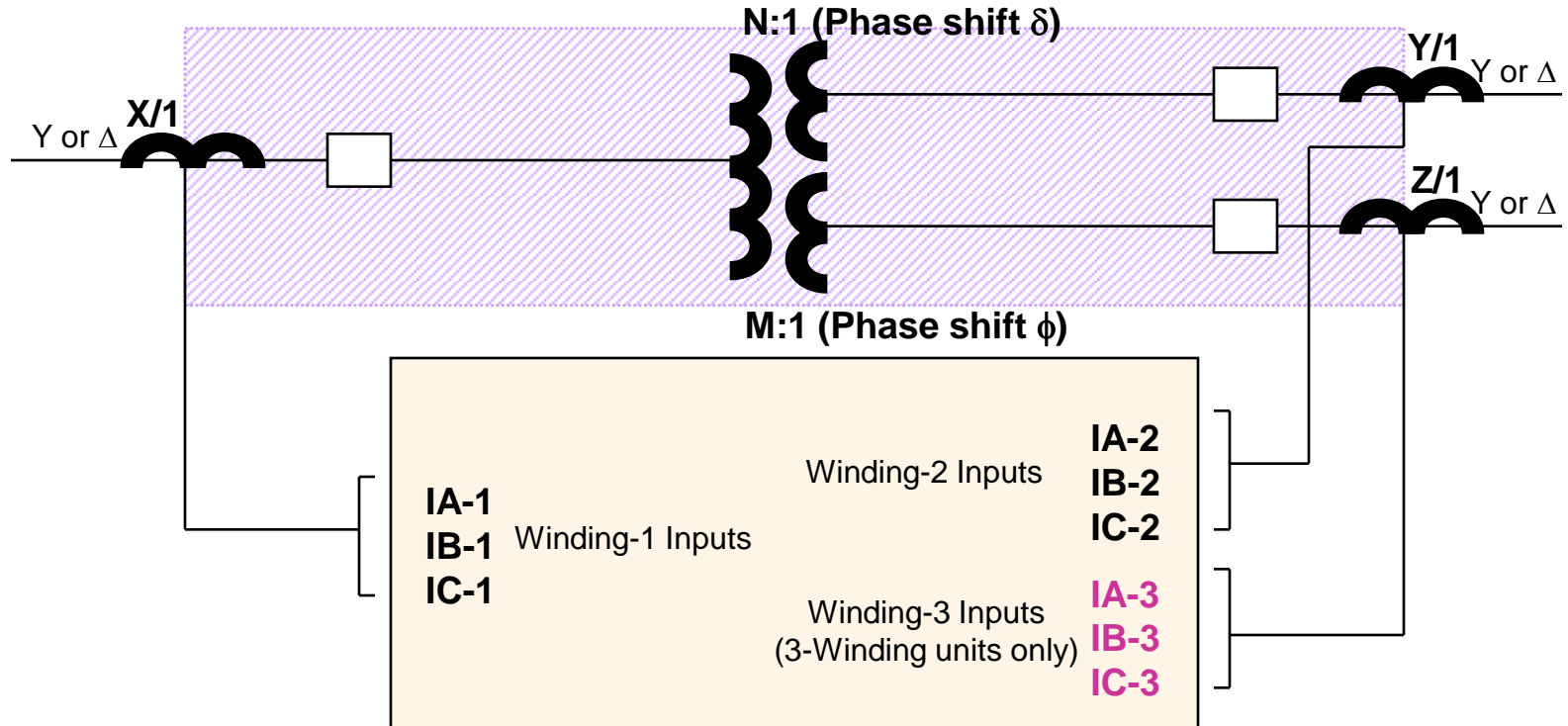

Differential protection

Non-trip zone for phase differential protection

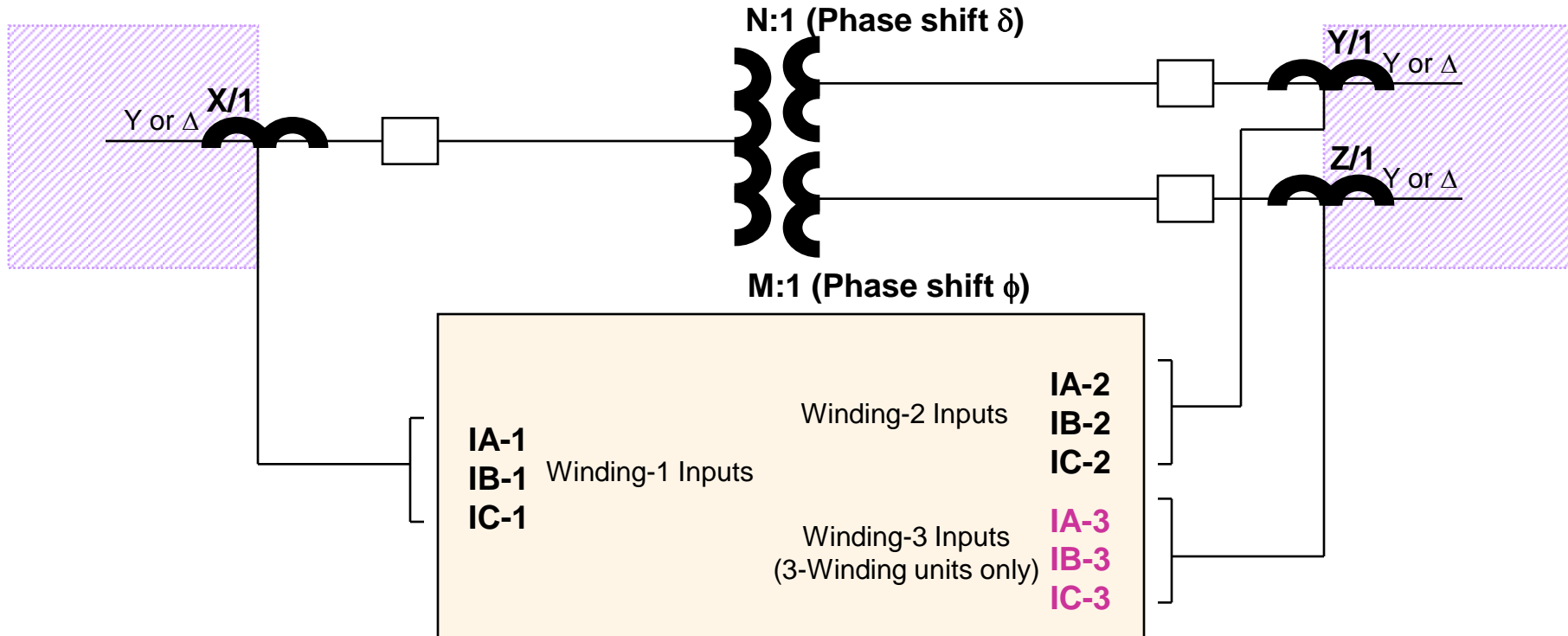

Differential protection

Ideally what comes in equals what goes out: $I_{OUT} = -I_{IN}$

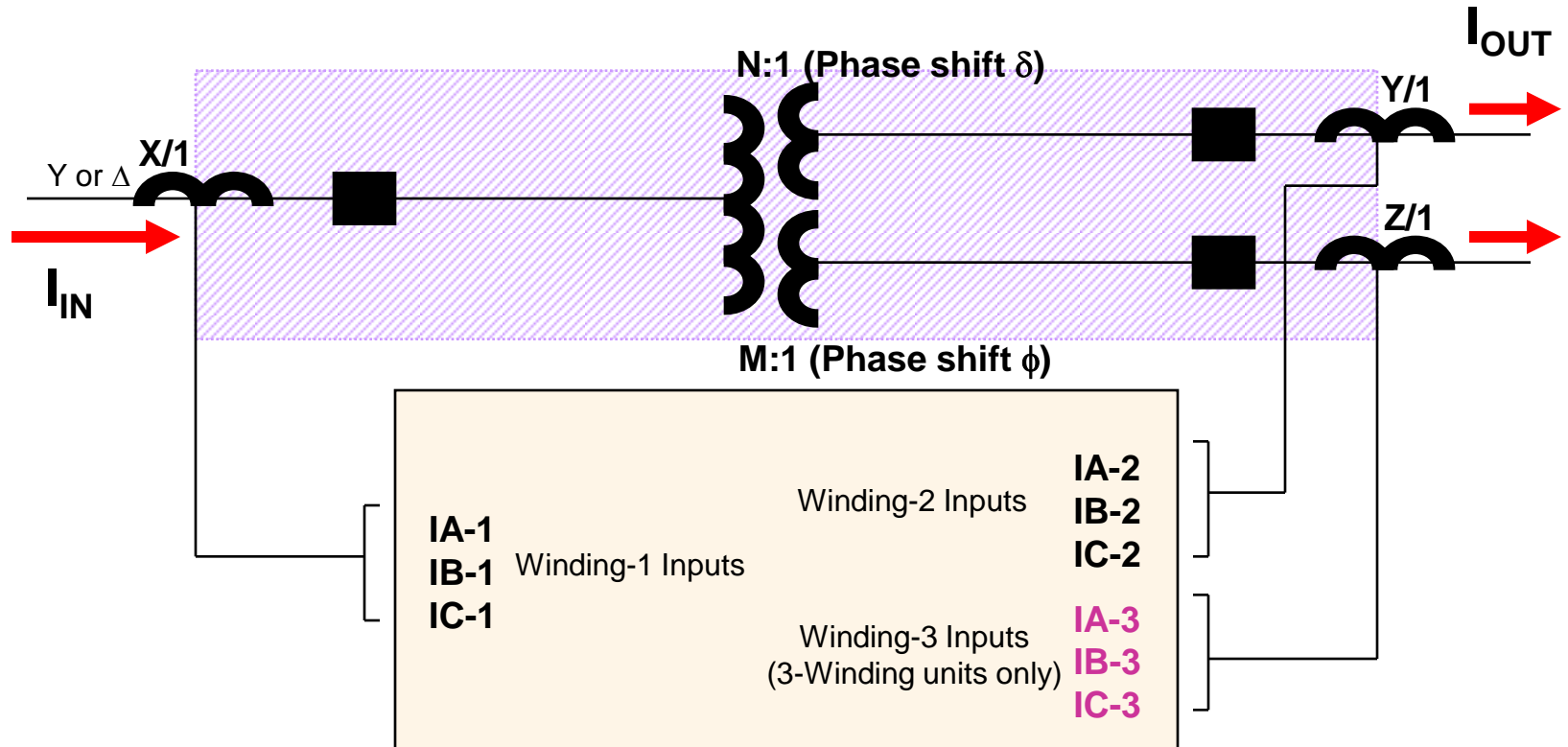

Differential protection

Transformer differential protection is generally quite simple, but requires the correct application and connection of current transformers and an understanding of the power transformer winding connections, characteristics and operation.

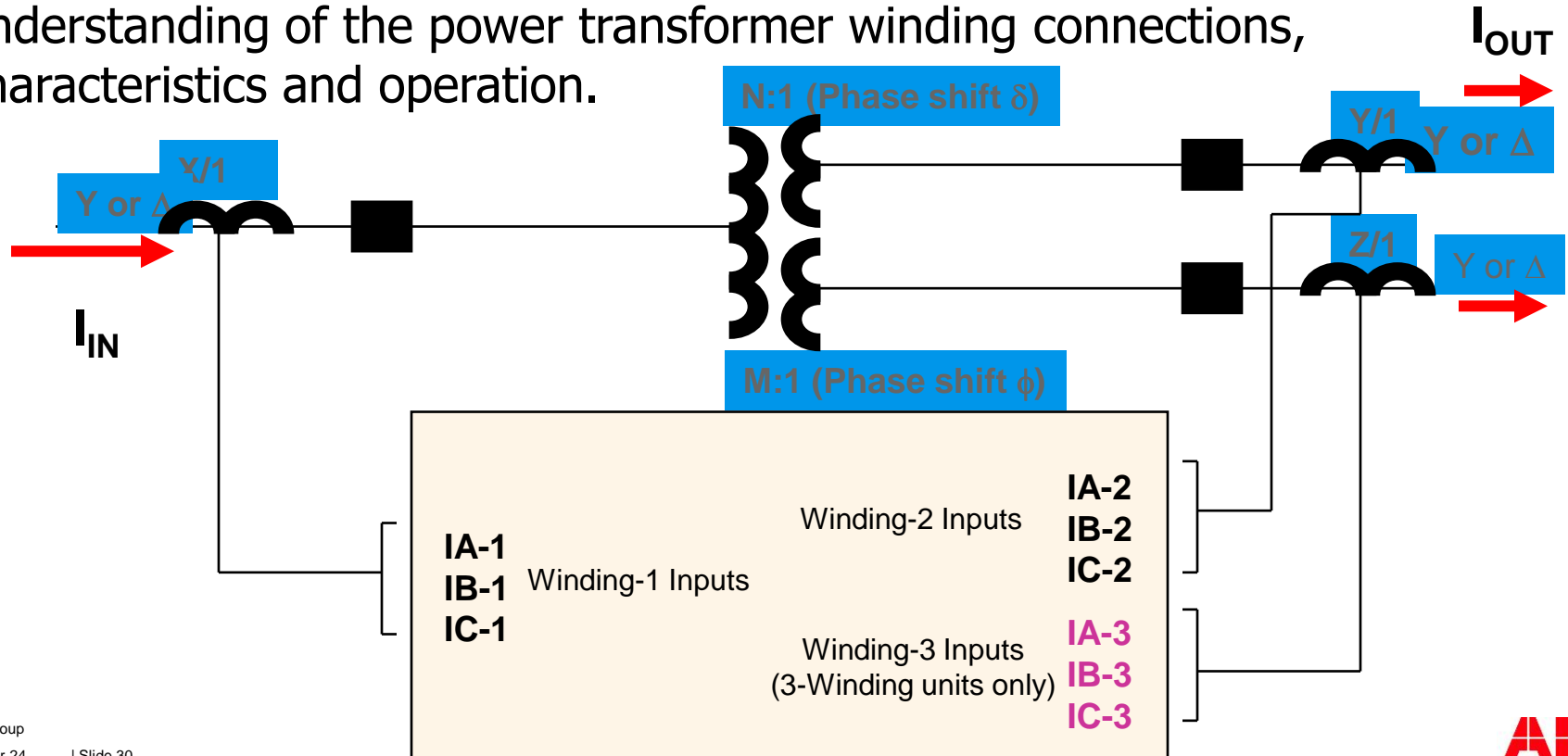

Transformer Differential Protection

- Unbalance currents due to factors other than faults
 - Currents that flow on only one side of the power transformer
 - Magnetizing currents that flow on only the power source side
 - Normal magnetizing currents
 - Inrush magnetizing currents
 - Overexcitation magnetizing currents
 - Currents that cannot be transformed to the other windings
 - Zero sequence currents
 - Error in the power transformer turns ratio due to OLTC
 - Inequality of the instrument current transformers
 - Different ratings of current transformers
 - Different types of current transformers

Transformer Differential Protection

- Unbalance currents due to factors other than faults (cont.)
 - Different relative loads on instrument transformers
 - Different relative currents on CT primaries
 - Different relative burdens on CT secondaries
 - Different DC time constants of the fault currents
 - Different time of occurrence, and degree, of CT saturation

Transformer Differential Protection

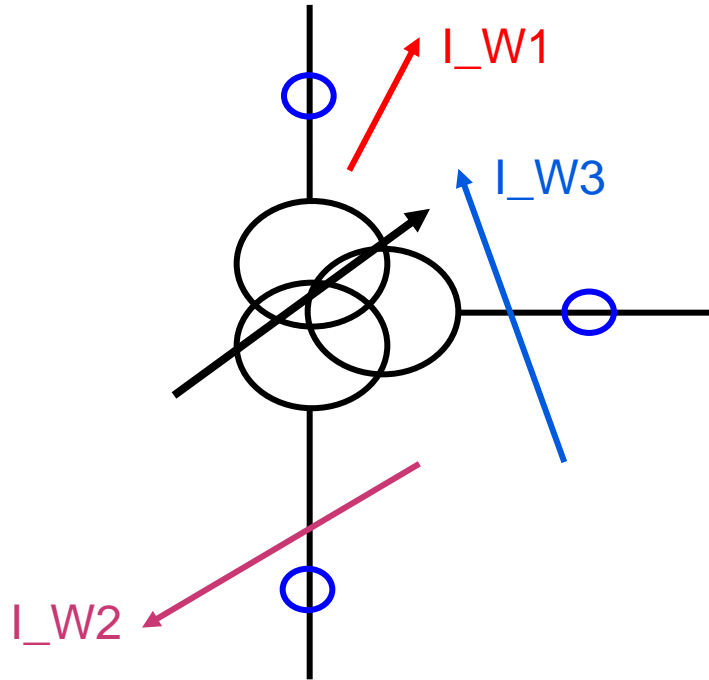

$$I_{W1} + I_{W2} + I_{W3} = 0 \text{ (?)}$$

- Practical problems

- Y, D or Z connections
- Different current magnitudes
- Different phase angle shift
- Zero sequence currents

Analog Differential Protection

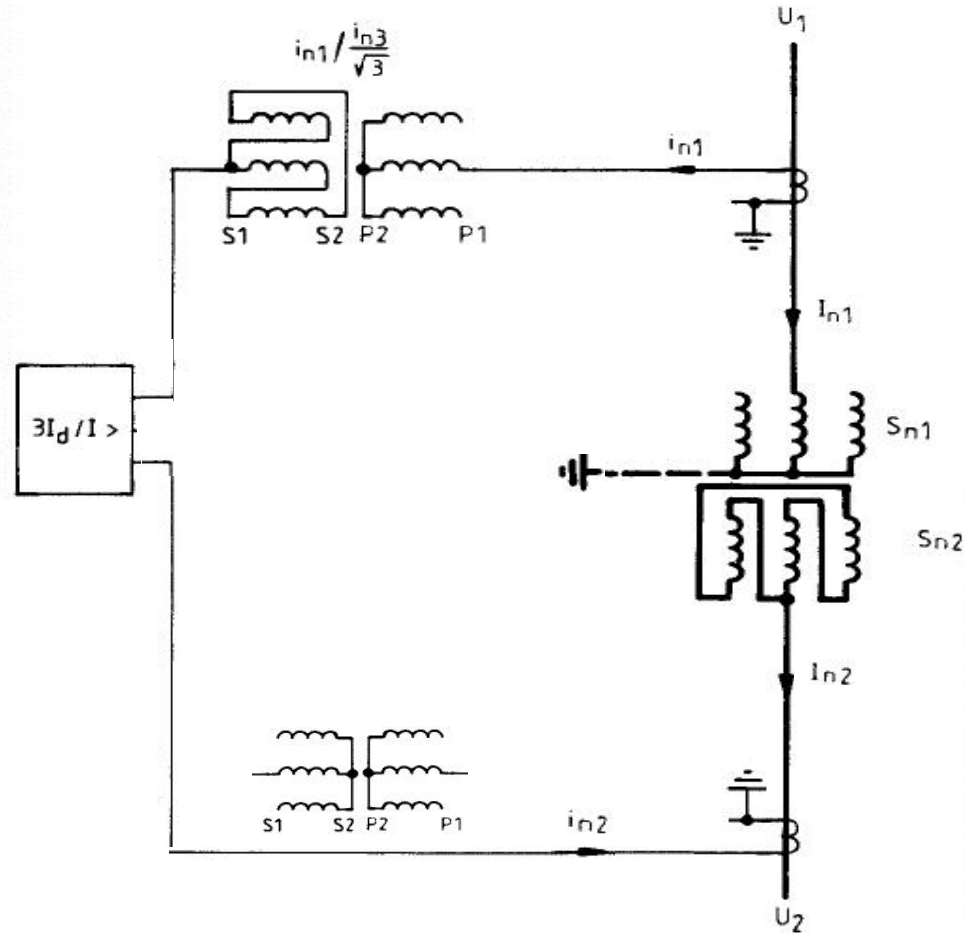

Numerical Differential Protection

- Typically, all CTs are directly star-connected to the IED
- The conversion of all current contributions is performed mathematically
 - Magnitude conversion of all current contributions to the magnitude reference side (normally the HV-side (W1), i.e. the magnitude of the current contribution from each side is transferred to the HV-side (W1))
 - Phase angle conversion of all current contributions to the phase reference side (using pre-programmed matrices). ABB: Phase reference is the first star-connected winding (W1→W2 →W3), otherwise if no star winding, first delta-connected winding (W1 → W2 →W3)
 - The power transformer connection type, the vector group and the subtraction of zero sequence currents (On/Off) are setting parameters – from these the differential protection calculates off-line the matrix coefficients, which are then used in the on-line calculations
 - If the subtraction of the zero sequence currents from the current contribution from any winding is required (set On), a matrix with different coefficients will be used (does both the phase angle conversion and zero sequence current subtraction)

Numerical Differential Protection

- Two-winding transformer

= 1 as W1 (HV-winding) is normally the magnitude reference

$$\begin{bmatrix} IDL1 \\ IDL2 \\ IDL3 \end{bmatrix} = \frac{Ur_W1}{Ur_W1} A \cdot \begin{bmatrix} IL1_W1 \\ IL2_W1 \\ IL3_W1 \end{bmatrix} + \frac{Ur_W2}{Ur_W1} B \cdot \begin{bmatrix} IL1_W2 \\ IL2_W2 \\ IL3_W2 \end{bmatrix}$$

Contribution from W1 side to differential currents
Contribution from W2 side to differential currents

$$\begin{bmatrix} DCCL1_W1 \\ DCCL2_W1 \\ DCCL3_W1 \end{bmatrix}$$

3x1 matrix

$$\begin{bmatrix} DCCL1_W2 \\ DCCL2_W2 \\ DCCL3_W2 \end{bmatrix}$$

3x1 matrix

Differential currents (in W1-side primary amperes)

- A, B are 3x3 matrices
- Values for the A, B matrix coefficients depend on
 - Winding connection type, i.e. star (Y/y) or delta (D/d)
 - Transformer vector group, i.e. Yd1, Yd5, etc (which introduces a phase shift between winding currents in multiples of 30°)
 - Zero sequence current elimination set On / Off

Numerical Differential Protection

- Three-winding transformer

= 1 as W1 (HV-winding) is normally the magnitude reference

$$\begin{bmatrix} IDL1 \\ IDL2 \\ IDL3 \end{bmatrix} = \frac{Ur_W1}{Ur_W1} \cdot A \cdot \begin{bmatrix} IL1_W1 \\ IL2_W1 \\ IL3_W1 \end{bmatrix} + \frac{Ur_W2}{Ur_W1} \cdot B \cdot \begin{bmatrix} IL1_W2 \\ IL2_W2 \\ IL3_W2 \end{bmatrix} + \frac{Ur_W3}{Ur_W1} \cdot C \cdot \begin{bmatrix} IL1_W3 \\ IL2_W3 \\ IL3_W3 \end{bmatrix}$$

Differential currents (in W1-side primary amperes)

Contribution from W1 side to differential currents $ \begin{bmatrix} DCCL1_W1 \\ DCCL2_W1 \\ DCCL3_W1 \end{bmatrix} $	Contribution from W2 side to differential currents $ \begin{bmatrix} DCCL1_W2 \\ DCCL2_W2 \\ DCCL3_W2 \end{bmatrix} $	Contribution from W3 side to differential currents $ \begin{bmatrix} DCCL1_W3 \\ DCCL2_W3 \\ DCCL3_W3 \end{bmatrix} $
---	---	---

Numerical Differential Protection

- Differential currents

- Fundamental frequency differential currents (per phase) – calculated as the vector sum of the fundamental frequency current contributions from all sides of the transformer

$$\begin{bmatrix} IDL1 \\ IDL2 \\ IDL3 \end{bmatrix} = \begin{bmatrix} DCCL1_W1 \\ DCCL2_W1 \\ DCCL3_W1 \end{bmatrix} + \begin{bmatrix} DCCL1_W2 \\ DCCL2_W2 \\ DCCL3_W2 \end{bmatrix}$$

Giving

$$IDL1 = DCCL1_W1 + DCCL1_W2$$

$$IDL2 = DCCL2_W1 + DCCL2_W2$$

$$IDL3 = DCCL3_W1 + DCCL3_W2$$

- Bias current

- ABB: Calculated as the highest fundamental frequency current amongst all the current contributions to the differential current calculation
- This highest individual current contribution is taken as the single common bias current for all three phases

i.e. $IBIAS = \text{MAX} [DCCLx_W1; DCCLx_W2]$ (single circuit breaker applications)



Numerical Differential Protection

- Zero sequence current elimination
 - Star-delta (Delta-star) transformers do not transform the zero sequence currents to the other side
 - For an external earth fault on the (earthed) star-side, zero sequence currents can flow in the star-side terminals, but not in the delta-side terminals (circulate in the delta-winding)
 - This results in false differential currents that consist exclusively of the zero sequence currents – if high enough, these false differential currents can result in the unwanted operation of the differential function
 - Elimination of the zero sequence currents is necessary to avoid unwanted trips for external earth faults - the zero sequence currents should be subtracted from the side of the power transformer where the zero sequence currents can flow for external earth faults

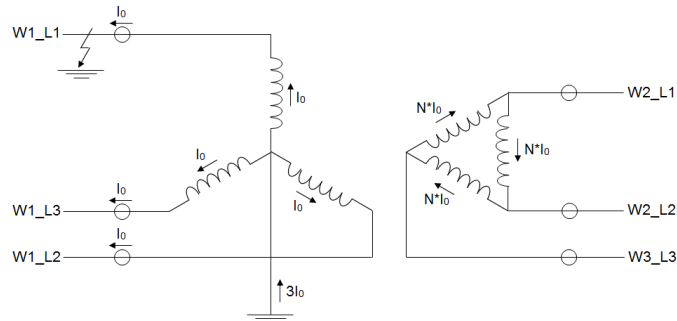

- For delta-windings, this feature should be enabled if an earthing transformer exists within the differential zone on the delta-side of the protected power transformer

Numerical Differential Protection

- Zero sequence current elimination

- Example: YNd1

$$\begin{bmatrix} IDL1 \\ IDL2 \\ IDL3 \end{bmatrix} = 1 \cdot A \cdot \begin{bmatrix} IL1_W1 \\ IL2_W1 \\ IL3_W1 \end{bmatrix} + \frac{Ur_W2}{Ur_W1} \cdot B \cdot \begin{bmatrix} IL1_W2 \\ IL2_W2 \\ IL3_W2 \end{bmatrix}$$

- Y-winding (W1/HV): phase reference, magnitude reference

- Zero sequence subtraction Off

$$A = \begin{bmatrix} 1 & 0 & 0 \\ 0 & 1 & 0 \\ 0 & 0 & 1 \end{bmatrix}$$

- Zero sequence subtraction On

$$A = \frac{1}{3} \cdot \begin{bmatrix} 2 & -1 & -1 \\ -1 & 2 & -1 \\ -1 & -1 & 2 \end{bmatrix}$$

- ABB: Phase reference is the first star-connected winding (W1→W2→W3), otherwise if no star winding, first delta-connected winding (W1→W2→W3)

- As the Y-winding (W1/HV) is the phase reference, the A matrix must not introduce a phase shift

Numerical Differential Protection

- Zero sequence current elimination

- Y-winding (W1/HV)

$$\begin{bmatrix} IDL1 \\ IDL2 \\ IDL3 \end{bmatrix} = 1 \cdot A \cdot \begin{bmatrix} IL1_W1 \\ IL2_W1 \\ IL3_W1 \end{bmatrix} + \frac{Ur_W2}{Ur_W1} \cdot B \cdot \begin{bmatrix} IL1_W2 \\ IL2_W2 \\ IL3_W2 \end{bmatrix}$$

- Zero sequence subtraction Off

$$A = \begin{bmatrix} 1 & 0 & 0 \\ 0 & 1 & 0 \\ 0 & 0 & 1 \end{bmatrix}$$

$$IDL1 = IL1_W1 + \dots$$

$$IDL2 = IL2_W1 + \dots$$

$$IDL3 = IL3_W1 + \dots$$

- If $IL1_W1 = IL1_W1' + I_0_W1$ (similarly for L2 and L3)

$$IDL1 = IL1_W1' + I_0_W1 + \dots$$

$$IDL2 = IL2_W1' + I_0_W1 + \dots$$

$$IDL3 = IL3_W1' + I_0_W1 + \dots$$

Numerical Differential Protection

- Zero sequence current elimination

- Y-winding (W1/HV)

$$\begin{bmatrix} IDL1 \\ IDL2 \\ IDL3 \end{bmatrix} = 1 \cdot A \cdot \begin{bmatrix} IL1_W1 \\ IL2_W1 \\ IL3_W1 \end{bmatrix} + \frac{Ur_W2}{Ur_W1} \cdot B \cdot \begin{bmatrix} IL1_W2 \\ IL2_W2 \\ IL3_W2 \end{bmatrix}$$

- Zero sequence subtraction On $A = \frac{1}{3} \begin{bmatrix} 2 & -1 & -1 \\ -1 & 2 & -1 \\ -1 & -1 & 2 \end{bmatrix}$

$$\begin{aligned} IDL1 &= \frac{2}{3} \cdot IL1_W1 - \frac{1}{3} \cdot IL2_W1 - \frac{1}{3} \cdot IL3_W1 + \dots \\ &= \frac{2}{3} \cdot (IL1_W1' + \cancel{I0_W1}) - \frac{1}{3} \cdot (IL2_W1' + \cancel{I0_W1}) - \frac{1}{3} \cdot (IL3_W1' + \cancel{I0_W1}) + \dots \\ &= \frac{2}{3} \cdot IL1_W1' - \frac{1}{3} \cdot IL2_W1' - \frac{1}{3} \cdot IL3_W1' + \dots \\ &= IL1_W1' + \dots \end{aligned}$$

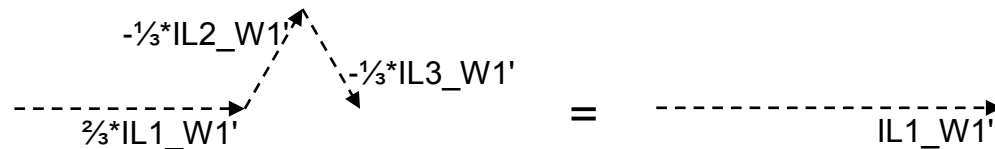

Similarly for IDL2 and IDL3

Numerical Differential Protection

- Balanced load flow

- Example: YNd1

$$\begin{bmatrix} IDL1 \\ IDL2 \\ IDL3 \end{bmatrix} = 1 \cdot A \cdot \begin{bmatrix} IL1_W1 \\ IL2_W1 \\ IL3_W1 \end{bmatrix} + \frac{Ur_W2}{Ur_W1} \cdot B \cdot \begin{bmatrix} IL1_W2 \\ IL2_W2 \\ IL3_W2 \end{bmatrix}$$

- $I_{OUT} = -I_{IN}$, so $IDL1 = 0$ ($I_{IN} + I_{OUT} = 0$) – similarly for $IDL2$, $IDL3$

- Y-winding (W1/HV)

- Zero sequence subtraction On

$$A = \begin{bmatrix} 1 & 0 & 0 \\ 0 & 1 & 0 \\ 0 & 0 & 1 \end{bmatrix}$$

$$IDL1 = IL1_W1 + \dots$$

Similarly for $IDL2$, $IDL3$

- Zero sequence subtraction Off

$$A = \frac{1}{3} \begin{bmatrix} 2 & -1 & -1 \\ -1 & 2 & -1 \\ -1 & -1 & 2 \end{bmatrix}$$

$$IDL1 = \frac{2}{3} \cdot IL1_W1 - \frac{1}{3} \cdot IL2_W1 - \frac{1}{3} \cdot IL3_W1 + \dots$$

$$= IL1_W1 + \dots$$

Similarly for $IDL2$, $IDL3$

Numerical Differential Protection

- Balanced load flow

$$\begin{bmatrix} IDL1 \\ IDL2 \\ IDL3 \end{bmatrix} = 1 \cdot A \cdot \begin{bmatrix} IL1_W1 \\ IL2_W1 \\ IL3_W1 \end{bmatrix} + \frac{Ur_W2}{Ur_W1} \cdot B \cdot \begin{bmatrix} IL1_W2 \\ IL2_W2 \\ IL3_W2 \end{bmatrix}$$

- d-winding (W2/LV)

$$B = \frac{1}{\sqrt{3}} \cdot \begin{bmatrix} 1 & -1 & 0 \\ 0 & 1 & -1 \\ -1 & 0 & 1 \end{bmatrix}$$

d1-winding lags reference Y-winding by 30°; matrix for winding lagging by 30°

$$\begin{aligned} IDL1 &= \dots + (Ur_W2/Ur_W1) \cdot 1/\sqrt{3} \cdot (IL1_W2 - IL2_W2) \\ &= \dots + (Ur_W2/Ur_W1) \cdot 1/\sqrt{3} \cdot (\sqrt{3} \cdot IL1_W2) \angle 30^\circ \\ &= \dots + (Ur_W2/Ur_W1) \cdot IL1_W2 \angle 30^\circ \\ &= \dots + -IL1_W1 \end{aligned}$$

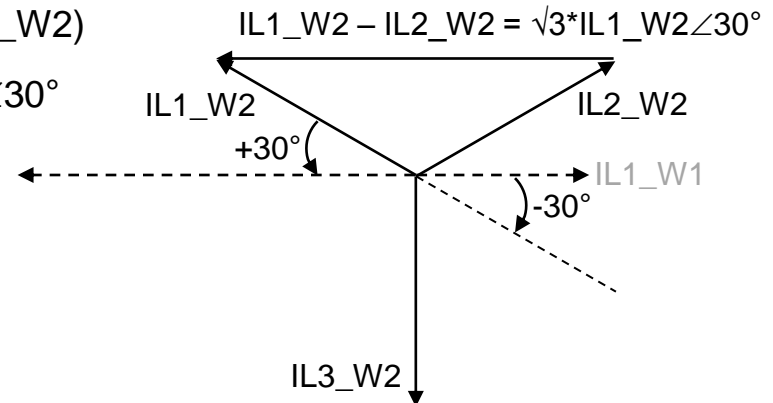

Numerical Differential Protection

- Balanced load flow

$$\begin{bmatrix} IDL1 \\ IDL2 \\ IDL3 \end{bmatrix} = 1 \cdot A \cdot \begin{bmatrix} IL1_W1 \\ IL2_W1 \\ IL3_W1 \end{bmatrix} + \frac{Ur_W2}{Ur_W1} \cdot B \cdot \begin{bmatrix} IL1_W2 \\ IL2_W2 \\ IL3_W2 \end{bmatrix}$$

- Therefore

$$IDL1 = IL1_W1 + -IL1_W1$$

$$= 0$$

Similarly for IDL2, IDL3

Differential protection settings

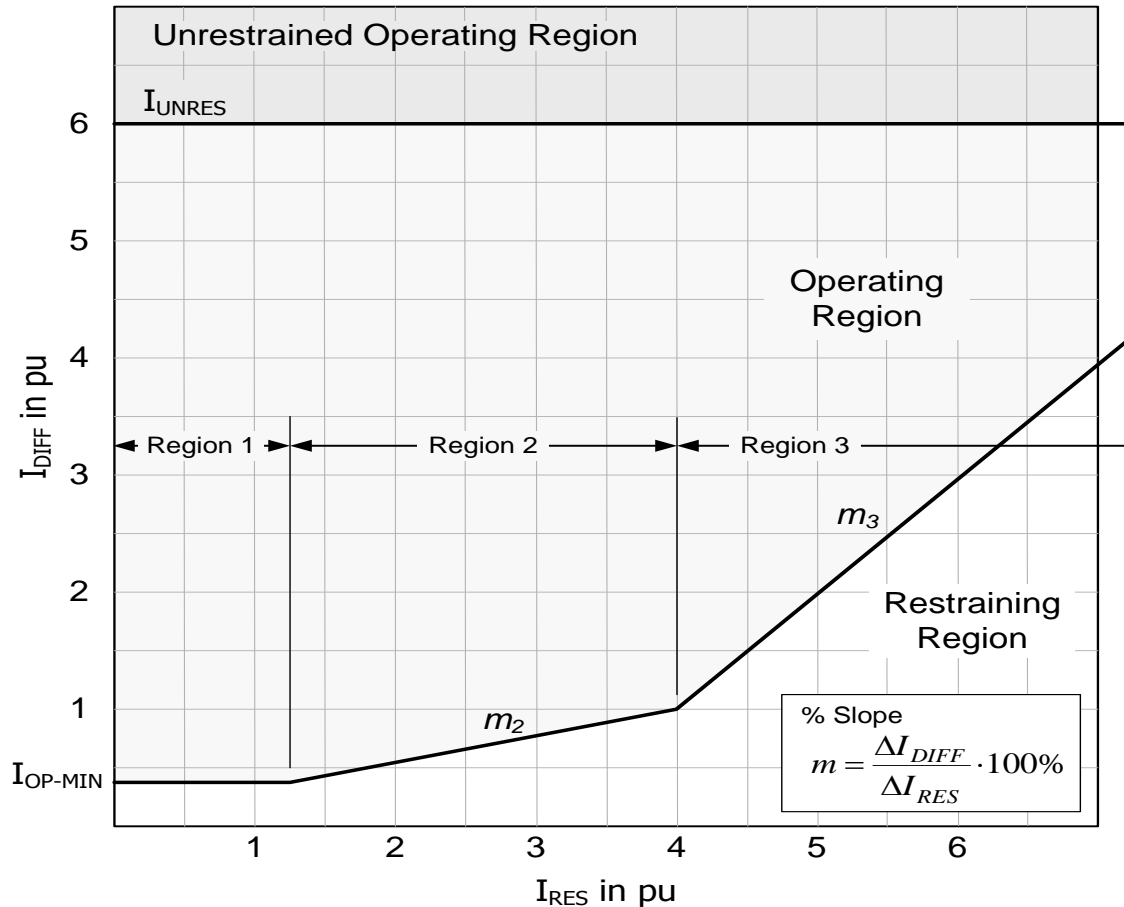

- Settings:
- I_{OP-MIN} : 0.3 - 0.4
 - $EndRegion1$: 1.25
 - $EndRegion2$: 3.0
 - $SlopeRegion2$ (m_2): 40%
 - $SlopeRegion3$ (m_3): 80%



Transformer Differential Protection

- Restrained (i.e. stabilized) characteristic

- Region 1
 - Most sensitive part
 - Characteristic a straight line
 - Current flow normal load current
 - Typical reason for existence of false differential currents in this section is non compensation for tap position
- Region 2
 - First slope (low percentage)
 - Caters for false differential currents when higher than normal currents flow through the current transformers
- Region 3
 - Second slope (higher percentage)
 - Provides higher tolerance to substantial current transformer saturation for high through fault currents, which can be expected in this section

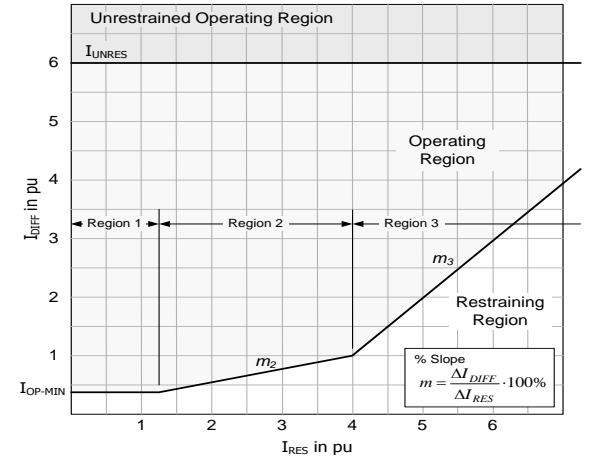

Numerical Differential Protection

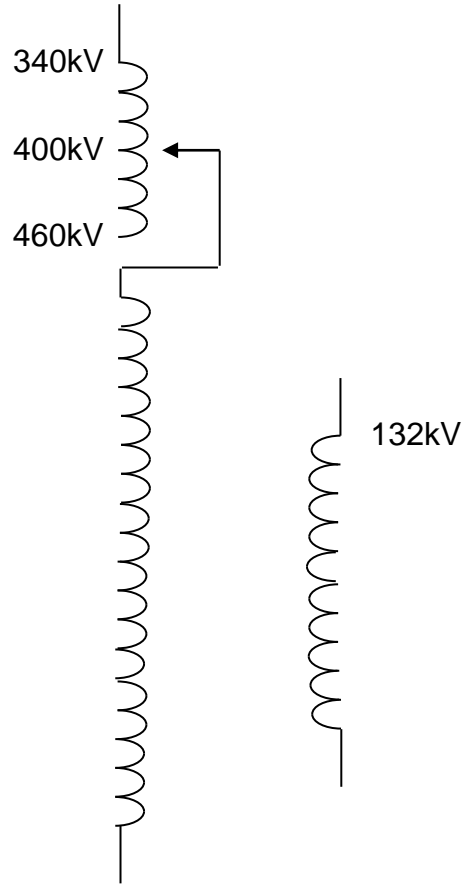

- On-load tap-changer

- Nameplate
 - 460kV
 - |
 - 400kV – 132kV
 - |
 - 340kV

- $I_{r_W1}n_{W1} = I_{r_W2}n_{W2}$ (effective turns ratio)

- $I_{r_W1} = \frac{S_r}{\sqrt{3}U_{r_W1}}$

$$I_{r_W2} = \frac{S_r}{\sqrt{3}U_{r_W2}}$$

- Therefore $\frac{n_{W1}}{n_{W2}} = \frac{U_{r_W1}}{U_{r_W2}}$

- $U_{r_W2} = \frac{n_{W2}}{n_{W1}} U_{r_W1}$

Numerical Differential Protection

- On-line compensation for on-load tap-changer (OLTC) movement
 - The OLTC is a mechanical device that is used to stepwise change the number of turns within one power transformer winding – consequently the overall turns ratio of the transformer is changed
 - Typically the OLTC is located on the HV winding (i.e. W1) – by stepwise increasing or decreasing the number of HV winding turns, it is possible to stepwise regulate the LV-side voltage
 - As the number of HV winding turns changes, the actual primary currents flowing will automatically adjust in accordance with

$$|I_{w1}n_{w1}| = |I_{w2}n_{w2}|$$

$$n_{w1}/n_{w2} = n = U_{r_W2} / U_{r_W1}$$

n = 'effective' turns ratio

- However, as the transformation ratio (turns ratio) changes, the differential function will calculate a resulting differential current if the ratio U_{r_W2} / U_{r_W1} is fixed in the calculation

$$\begin{bmatrix} IDL1 \\ IDL2 \\ IDL3 \end{bmatrix} = 1 \cdot A \cdot \begin{bmatrix} IL1_W1 \\ IL2_W1 \\ IL3_W1 \end{bmatrix} + \frac{U_{r_W2}}{U_{r_W1}} \cdot B \cdot \begin{bmatrix} IL1_W2 \\ IL2_W2 \\ IL3_W2 \end{bmatrix}$$

Numerical Differential Protection

- On-line compensation for on-load tap-changer (OLTC) movement

$$\begin{bmatrix} IDL1 \\ IDL2 \\ IDL3 \end{bmatrix} = 1 \cdot A \cdot \begin{bmatrix} IL1_W1 \\ IL2_W1 \\ IL3_W1 \end{bmatrix} + \frac{Ur_W2}{Ur_W1} \cdot B \cdot \begin{bmatrix} IL1_W2 \\ IL2_W2 \\ IL3_W2 \end{bmatrix}$$

- By knowing the actual tap position, the differential function can then calculate the correct no-load voltage for the winding on which the OLTC is located
- For example, if the OLTC is located on the HV winding (W1), the no-load voltage Ur_W1 is a function of the actual tap position – so for every tap position the corresponding value for Ur_W1 can be calculated and used in the differential current calculation
- The differential protection will be ideally balanced for every tap position and no false differential current will appear irrespective of the actual tap position
- Typically, the minimum differential protection pickup for power transformers with OLTC is set between 30% to 40% - however, with the OLTC compensation feature it is possible to set the differential protection to more sensitive pickup values of 15% to 25%

Transformer differential protection 101

- Transformers with Delta and Wye windings
 - Phase shift and magnitude ($\sqrt{3}$) compensation must be applied
 - Zero sequence currents for external ground faults must be blocked
- Solution
 - Analog Differential Protection
 - CT on the Wye side connected in Delta
 - CT on delta side connected in Wye
 - Numerical Differential Protection
 - Connect all winding CTs in Wye
 - Apply compensating factors and I_0 filtering
 - *Vendor Specific*

Transformer Differential Protection

- Blocking criteria (phase segregated)
 - Two blocking criteria – harmonic restrain and waveform restrain

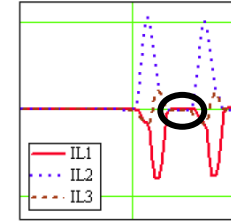

- Have the power to block a trip – prevents unwanted tripping due to CT saturation, magnetizing inrush currents, or due to magnetizing currents caused by overvoltages
 - Magnetizing currents (inrush / overvoltage) flow only on one side of a power transformer, and are therefore always a cause of false differential currents
- Performed on instantaneous differential currents – the same matrix equations are used as for the fundamental frequency currents, except now instantaneous values (i.e. sampled values) are used instead
 - Waveform – inrush
 - 2nd harmonic – inrush, CT saturation
 - 5th harmonic – overexcitation
- Cross-blocking: a blocking condition established in any phase can be ‘crossed’ to the other phases, i.e. detection in one phase blocks all phases

Inrush Current

- The size of the transformer
 - The peak value of the magnetizing inrush current is generally higher for smaller transformers
 - Duration of the inrush current is longer for the larger transformers
- The location of energized winding (inner, outer)
 - Low Voltage winding that is wound closer to the magnetic core has less impedance than the outer winding – consequently energizing the transformer from the LV winding will cause more inrush than energizing from the HV winding
 - Typical values:
 - LV side: magnitude of inrush current is 10-20 times the rated current
 - HV side: magnitude of inrush current is 5-10 times the rated current
- The connection of the windings

Inrush Current

- The point of wave when the switch closes – switching instant
 - The maximum inrush current will happen when the transformer is switched at voltage zero
 - Statistical data indicates every 5th or 6th transformer energization will result in high values of inrush
- The magnetic properties of the core
 - Remanence (residual flux) in the core
 - Higher remanence results in the higher inrush
- The source impedance and transformer air-core reactance
 - EG. lower source impedance results in the higher inrush

Inrush Current

- Magnetizing inrush current can appear in all three phases and in an earthed neutral
- The inrush current has a large DC component that may saturate the CTs
- There is a risk that sensitive differential protection, residual overcurrent protection and neutral point overcurrent protection may operate incorrectly
- Phase O/C protection can maloperate

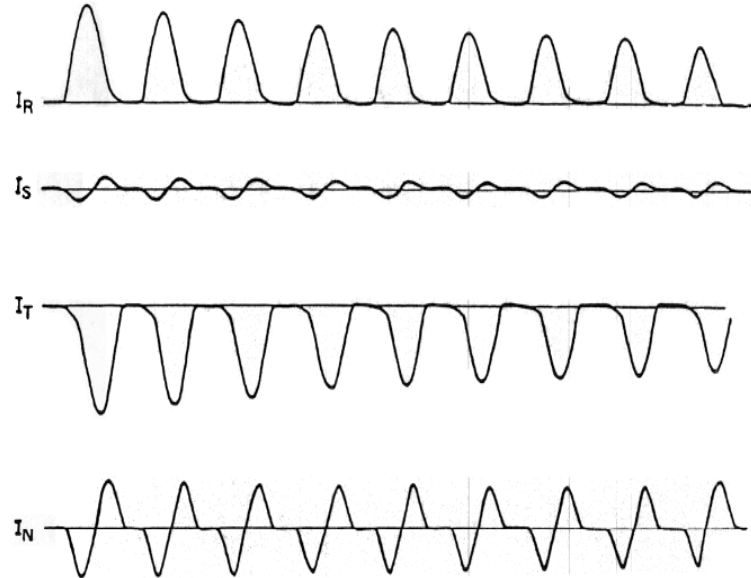

Inrush Current

- Differential protection commonly uses 2nd harmonic value to distinguish between inrush current and short circuit current – 2nd harmonic > threshold used to block differential operation
 - Normal operation / internal short circuits have only small 2nd harmonic in current
 - Inrush current has significant 2nd harmonic
 - 2nd harmonic in currents small during over voltages

Overvoltage / Overexcitation Current

- Overexcitation exists if the per unit V/Hz exceeds the design limit of transformer
 - Overexcitation waveform produces predominately high odd harmonics ... 3rd, 5th, 7th, ...

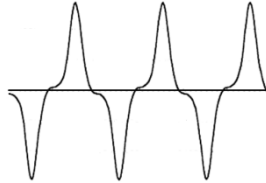

- Protection commonly uses 5th harmonic value to distinguish overexcitation current – 5th harmonic > threshold used to block differential operation
 - 3rd harmonic not used as they are a prevalent quantity on the power system produced from many sources
- Separate V/Hz function normally used to provide tripping for overexcitation

Overexcitation Function

- It follows from the fundamental transformer equation.....

$$E = 4.44 \cdot f \cdot n \cdot B_{\max} \cdot A$$

.....that the peak magnetic flux density B_{\max} is directly proportional to the internal induced voltage E , and inversely proportional to the frequency f , and the turns n – overexcitation results from a too-high applied voltage, or below-normal frequency

- Disproportional variations in E and f may give rise to core overfluxing – such an overexcitation condition will produce
 - Overheating (of the non-laminated metal parts, as well as an increase in the core and winding temperature)
 - Increase in magnetizing currents
 - Increase in vibration and noise
- Protection against overexcitation is based on calculation of the relative Volts per Hertz (V / Hz) ratio – 24 function

Transformer Differential Protection – Neg Seq

- Internal / External fault discriminator

- Fault position (internal / external) determined by comparing the direction of flow of the negative sequence currents (determines the position of the source of the negative sequence currents with respect to the zone of protection)
- Transformation ratio and phase shift – before comparison, the negative sequence currents must first be referred to the same phase reference, and put to the same magnitude reference – matrix equation

$$\begin{bmatrix} IDL1_NS \\ IDL2_NS \\ IDL3_NS \end{bmatrix} = \frac{1}{3} \cdot \begin{bmatrix} 2 & -1 & -1 \\ -1 & 2 & -1 \\ -1 & -1 & 2 \end{bmatrix} \cdot \begin{bmatrix} INS_W1 \\ a \cdot INS_W1 \\ a^2 \cdot INS_W1 \end{bmatrix} + \frac{Ur_W2}{Ur_W1} \cdot \frac{1}{\sqrt{3}} \cdot \begin{bmatrix} -1 & 0 & 1 \\ 1 & -1 & 0 \\ 0 & 1 & -1 \end{bmatrix} \cdot \begin{bmatrix} INS_W2 \\ a \cdot INS_W2 \\ a^2 \cdot INS_W2 \end{bmatrix}$$

- External fault: the negative sequence currents will have a relative phase angle of 180°
- Internal fault: the negative sequence currents will have a relative phase angle of about 0°

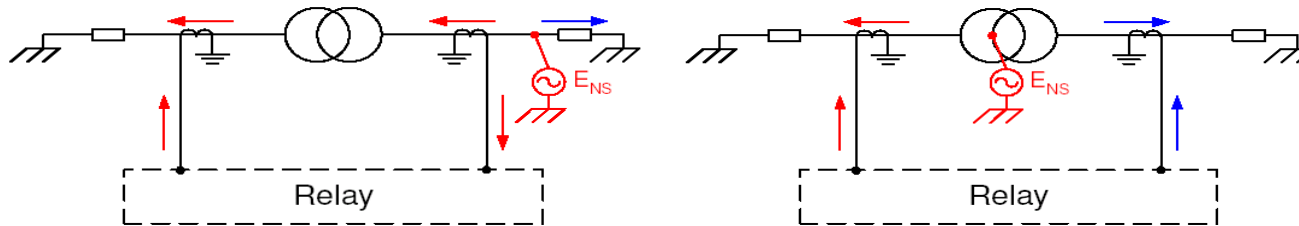

- 3ph faults – a negative sequence current source will be present until the dc component in the fault currents die out

Transformer Differential Protection – Neg Seq

- Internal / External fault discriminator

- Discriminates between internal and external faults with very high dependability
- Detects even minor faults with high sensitivity and high speed
- Combine features of the internal / external fault discriminator with conventional differential protection
 - Unrestrained negative sequence differential protection
 - Fast operating time, even for heavy internal faults with severely saturated CTs – typically < 1 cycle ($\pm 3/4$ cycle)
 - Sensitive negative sequence protection
 - Sensitive turn-to-turn fault protection

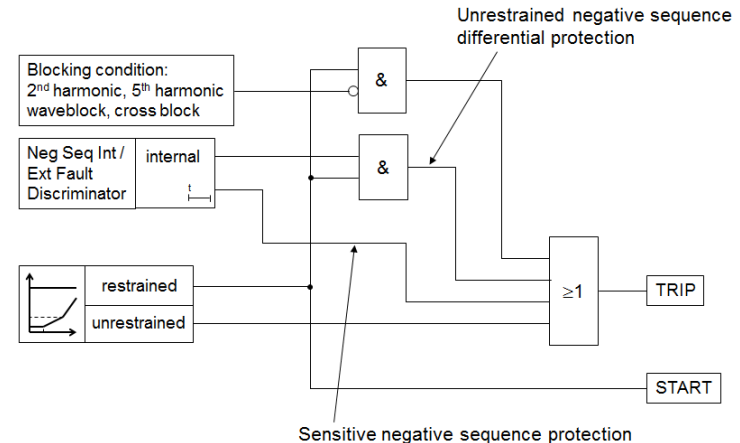

Turn-to-turn fault detection

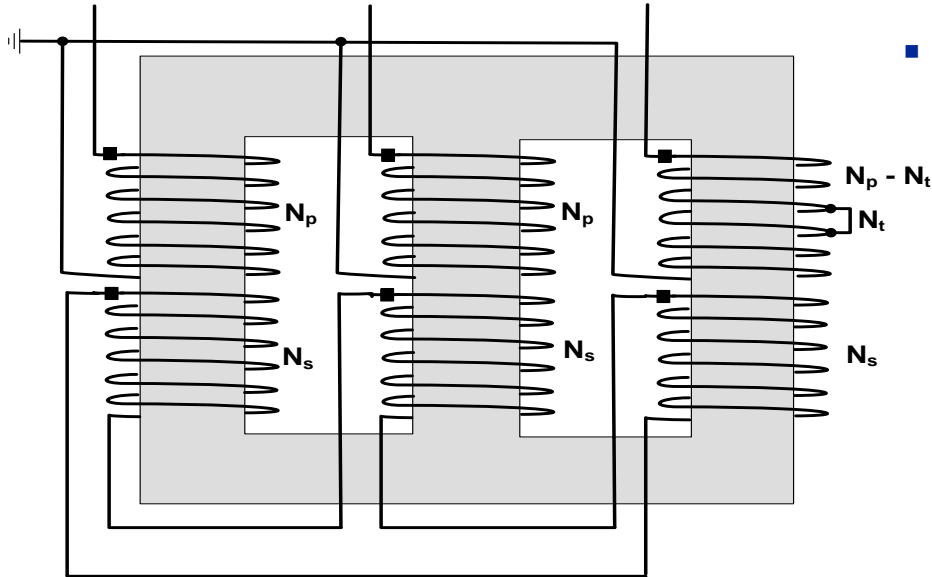

Turn-to-turn fault

- Usually involves a small number of adjacent turns
- A small unbalance in primary to secondary turns ratio,

$$(N_p - N_t) / N_s$$

- Undetectable with normal differential protection
- High current in shorted turns
- Sudden Pressure Relay (SPR)
 - Slow
 - Tendency to misoperate
- Negative sequence differential

Turn to turn fault detection

- Turn to turn faults do not immediately result in high fault currents which can be detected by the conventional 87T or over current backup protection
- In a 2 winding transformer:
 - $I_{w1}n_{w1} = I_{w2}n_{w2}$ (Amp Turn balance)
 - When a turn to turn short occurs
 - Very high currents through the inter-turn short
 - Hot spot stressing of insulation – potentially giving further insulation breakdown and a higher magnitude fault
 - Turn to turn faults result in a source of negative sequence current due to asymmetry in the number of turns across the phases of the faulted winding
 - Turn to turn faults can be detected based on the direction of flow of the negative sequence currents

Transformer Differential Protection

- Other features
 - Open CT detection
 - Switch-on-to-fault

Restricted earth fault

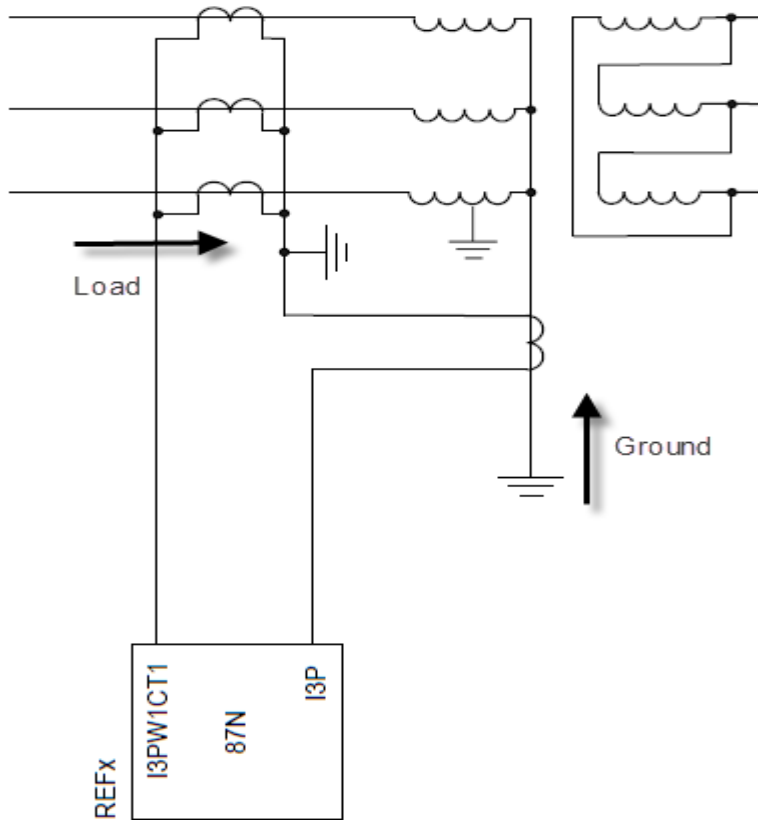

- 3I0 differential protection

- $I_{Diff} = 3I_{0G} + 3I_{0L}$
- Greater sensitivity to faults near the neutral point of the transformer where the driving voltage is small for regular 87T to detect faults
- Compares direction between 3I0L and 3I0G
 - If in phase fault is internal
 - If 180 out of phase fault is external

Overcurrent protection coordination

- Time-overcurrent protection
 - Inverse time characteristic relay provides the best coordination
 - Settings of 200 to 300% of the transformer's self-cooled ratings
 - Fast operation is not possible (coordination with other relays)

- Instantaneous protection
 - Fast operation on heavy internal faults
 - Settings 125% of the maximum through fault (low side 3F fault)
 - Settings should be above the inrush current

Overcurrent protection coordination

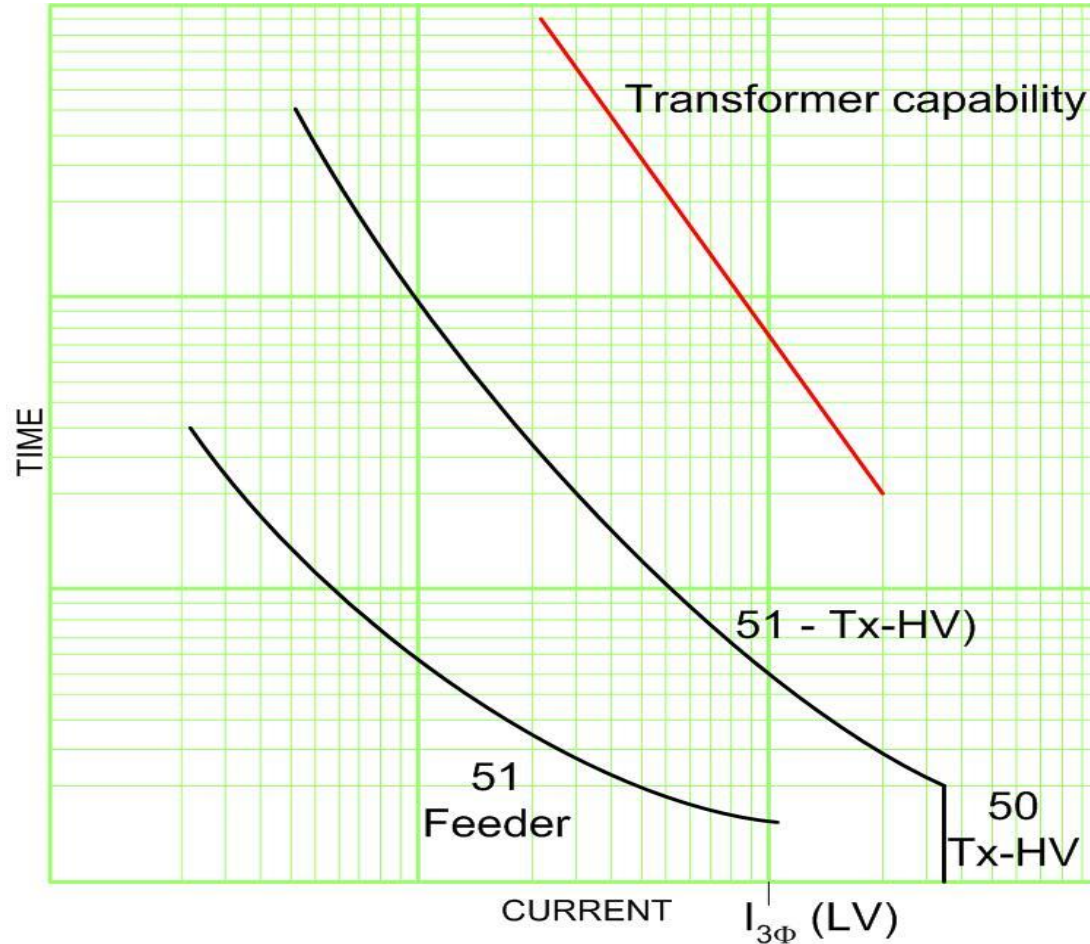

Typical protection scheme for power transformer

- Transformer differential 87T (incl negative sequence turn-turn fault detection)
- Restricted earth fault 87N
- SPR and Buchholtz 63
- Phase over current 50/51P (backup)
- Ground over current 51G (backup)
- Thermal overload 49
- Over excitation 24

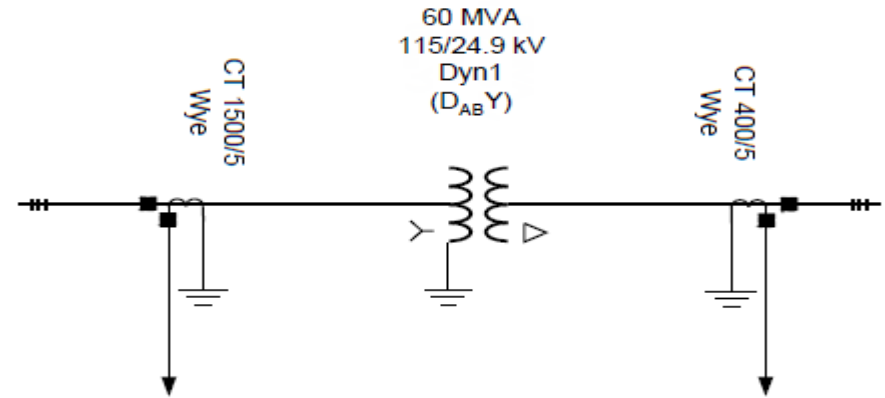

Relion® RET650/670 next generation transformer protection

Reliable protection and control of power transformers and reactors



RET650
The best choice for sub-transmission applications



RET670
Optimized for transmission applications

- Achieve significant savings in configuration and commissioning with efficient system integration and optimum “off-the-shelf” solutions and settings
- Do more with less - the advanced logic and multipurpose functionality allow you to customize protection schemes for multiple objects with a single IED
- Protect your investment with unrivalled sensitivity, speed and the best possible protection for power transformer winding turn-to-turn faults
- Maximize flexibility and performance with powerful application and communication capabilities that allow you to integrate these IEDs into new or retrofit substation automation systems or use them as stand-alone multifunctional units

Thank you for your participation

Shortly, you will receive a link to an archive of this presentation.
To view a schedule of remaining webinars in this series, or for more
information on ABB's protection and control solutions, visit:

www.abb.com/relion

ABB Protective Relay School Webinar Series

Disclaimer

ABB is pleased to provide you with technical information regarding protective relays. The material included is not intended to be a complete presentation of all potential problems and solutions related to this topic. The content is generic and may not be applicable for circumstances or equipment at any specific facility. By participating in ABB's web-based Protective Relay School, you agree that ABB is providing this information to you on an informational basis only and makes no warranties, representations or guarantees as to the efficacy or commercial utility of the information for any specific application or purpose, and ABB is not responsible for any action taken in reliance on the information contained herein. ABB consultants and service representatives are available to study specific operations and make recommendations on improving safety, efficiency and profitability. Contact an ABB sales representative for further information.

Power and productivity
for a better world™



