

# BENEFITS OF INTEGRATED PROTECTION AND CONTROL SYSTEM FOR MV/LV GENERATORS FOR RELIABLE OPERATION IN THE PETROLEUM & CHEMICAL INDUSTRY

Copyright Material PCIC Europe  
Paper No. PCIC Middle-East ME17\_24

Prashant Ganoo  
ABB Oy  
Muottitie 2A, Vaasa  
Finland

Olli Rintamaki  
ABB Oy  
Muottitie 2A, Vaasa  
Finland

Sharad K. Dwivedi  
Shell Global Solutions  
International B.V.  
Netherlands

Arinjai Gupta  
ABB Global Industries  
Bangalore  
India

**Abstract** - This paper discusses Integrated Protection and Control solution for medium size generators (typical machine size around 50MW) to be applied in petroleum and chemical industry utilizing modern generator protection and control devices. As with any continuous running process plant, the availability of power is of paramount importance and so is the case of having most reliable Protection & Control solution to protect these vital generators. Also discussed is the redundancy approach with overlapping protection zones / protections to increase the overall reliability, utilization of novel (enhanced) protection functionalities (earlier available only for large size machines) to further enhance the selectivity with functions such as Out-of-Step protection, 100% Stator Earth fault protection, Arc Protection and need for having frequency adaptiveness (10-75 Hz) to ensure protection availability during machine start-up phase. The proposed solution utilizing highly-available and fast Ethernet network based on the IEC 61850 protocols permits integration of rugged field devices with reduced cabling to provide measurement signals over optical station bus for the purpose of control, monitoring and protection. Thus developed system solution is capable of simultaneous communication to Power Distribution System as well as Process Control System. Also discussed is the system wide Auto synchronization and control functionality providing operator convenience. The proposed generator protection and control solution increases overall reliability with fewer components at lower costs.

**Index Terms** – Generator Protection, redundancy, frequency-adaptiveness, out-of-step protection, auto synchronizer, IEC61850, GOOSE.

## I. INTRODUCTION

Generator protective relaying technology has evolved from discrete electromechanical and static relays to multifunctional numerical communicable protection & control systems. Specifically in petroleum and chemical industry where generators are applied as main power source and grid as backup, the availability of the protection is of paramount importance. Quite often, these single function relays were provided with “main” and “back-up” arrangement. With the availability of multifunction protection devices, we now have a possibility to further increase availability of protection and overall reliability by considering the main-1 and main-2 approach. With the increased availability, additional performance, economic advantages, and reliability of digital multifunction protection systems, this technology is being considered for new protection schemes. Quite often new generators are being

protected with either dual multifunction generator protection systems (MGPS) or a single multifunction generator protection, possibly backed up by some single function relays. Some modern excitation systems also contain protection functions that may be considered as back-up.

Due to the increased demand for the faster information supply, better coordination and faster management of emergency situations, more complex network configurations and the greater importance of continuity of supply, modern generator protection equipment has to fulfil much greater demands with regard to memory, capacity, measuring principles, availability and reliability as well as communication with the possibility to exchange data with the station control system and other protection relays.

In addition to the actual protective functions, features such as tripping logics, event recording, registration, signaling, self-monitoring and testing facilities all form an integral part of a protection system. In the interest of greater reliability and availability it is essential that all these supplementary functions be standardized and accommodated together with the protective functions in a factory-wired cubicle to form a single unit, which only needs to be connected to the instrument transformers, circuit breaker tripping coils, alarm circuits and station control or remote control system etc. With continuous self-monitoring, the availability of the protection system will be improved and with drawout designs of modern MGPS, the mean time to repair (MTTR) can be further brought down to few hours or even less.

Digital technology offers several additional features that could not be obtained in one package with earlier technology. These features include: metering of voltages, currents, power, and other parameters; oscillography; sequence of events capture with time tagging; remote setting and monitoring through communications; user configurability of tripping schemes and other control logic; reduced panel space and wiring; low burden on the VTs and CTs; continuous self-checking and ease of calibration/testing.

This paper explains the benefits of different types of redundant systems for protection and control in medium-sized generators applied in petroleum and chemical industry.

Section II describes various possible options such as redundant, backup and two-out-of-three systems.

Section III describes the required protections for the GTG startup based on a case in the P&C industry.

Section IV describes the out-of-step protection and its basic principles.

Section V details the auto synchronizer control solution in multifunction protection relays. Section VI summarizes the conclusions.

## II. RELIABLE PROTECTION & CONTROL SYSTEMS

Increasing demand of reliable generation requires priority to deliver the highest system availability at the lowest possible cost. This can be noticed in the industry, where electricity supply comprises a fundamental role in its processes. Moreover, redundancy is specified in official homologations to meet the required quality standards by a government or a regulatory entity, for instance, in the electricity sector and industry.

### A. Redundancy vs. Backup

Redundancy is defined, according to IEEE, as “the existence of more than one means for performing a given task” [2]. This term has been changing over the decades due to lack of standardization, so it can be interpreted differently, depending on the context. A redundant system does not need to be identical; however, its ability to accomplish a given task in case of failure must meet the same performance of the sound condition.

Conversely, a backup system does not necessarily meet the same performance rates, for instance, backup system may have lower speed or lower selectivity levels. In many cases, the backup device is not immediately available to replace a faulty device. In some substations, one backup unit is used to replace a number of on-line devices.

### B. Two-out-of-Three Voting Scheme

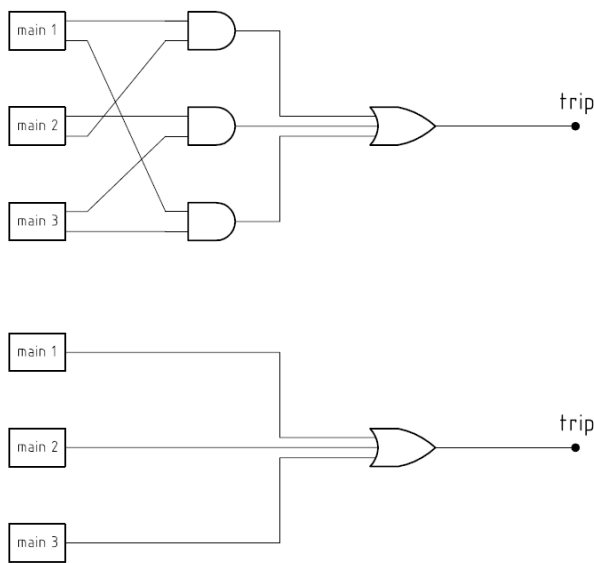

Fig. 1 Protection scheme with three relays in the two-out-of-three voting scheme (above) and redundant scheme with three relays (below). In the first, at least two relays

must send a trip signal in order to trigger the trip, while in the latter at least one must be available.

The two-out-of-three voting scheme is a variation of redundancy. In its general formulation, it is defined as the majority of an odd number of components, in this context, relays, is sufficient to trigger the trip of the protective device. In this particular case, two-out-of-three means that at least a combination of two relays can trigger the trip signal. This is a strategy to avoid false tripping.

The connections in this configuration is exemplified in Fig. 1.

### C. Impact on Reliability

Table I shows the probability of failure, probability of false trip and unavailability per year in four configurations: only 1 relay; main relay and backup relay; two main relays; and two-out-of-three scheme. This considers a failure rate of 0.01 fail/year, probability of false trip in the relay as  $10^{-4}$  and a mean time to failure (MTTR) of 10 hour/fail for the relay and considering that in all configurations using the same relay (same parameters). [2]

TABLE I.  
COMMONLY INSTALLED RELAY CONFIGURATIONS.

Configuration	Prob. of false trip	Prob. of failure	Unavailability [min/year]
Main	$1.0 \cdot 10^{-4}$	$1.1 \cdot 10^{-5}$	6
Main + backup	$1.0 \cdot 10^{-4}$	$1.1 \cdot 10^{-5}$	6 + replacement time*
Main 1 + main 2	$2.0 \cdot 10^{-4}$	$1.3 \cdot 10^{-10}$	$6.9 \cdot 10^{-5}$
Two-out-of-three	$10^{-12}$	$3.9 \cdot 10^{-10}$	$2.1 \cdot 10^{-4}$

\*Value varies greatly

For the backed up configuration, the replacement time depends on a number of factors. For instance, how complex it is to replace the failed relay. With some old relays, this can extend to several hours. In the best cases, the replacement time can be as low as 30 minutes. Some manufacturers offer the draw-out design using a handle that drastically decreases the MTTR.

## III. FREQUENCY ADAPTIVENESS NEED FOR GAS TURBINE GENERATOR PROTECTION AT START UP

Gas turbine generator (GTG) are integral part of oil/gas/chemicals industries to fulfil the need of in-house power demand. Start-up of GTG differs from that of conventional steam turbine coupled generators (STG) and hence need for generator protection also differs in GTG [1].

Gas turbine is not able to generate the torque at zero speed i.e. not capable of self-start hence require the additional starting mechanism. In case gas turbine starts up using separate speed drives (electrical motor or diesel engine), the field excitation is switched on after achieving the 95% or more of nominal speed hence generator protection needed is limited to 95% to 105% of nominal frequency range. In case of big machine where line commutated inverter with variable speed

drive is used as starting mechanism, field excitation is on at very low speed. Hence generator protection needed is from very low frequency to 105% of nominal frequency range. Main step for starting up GTG and STG is shown in figure 2.

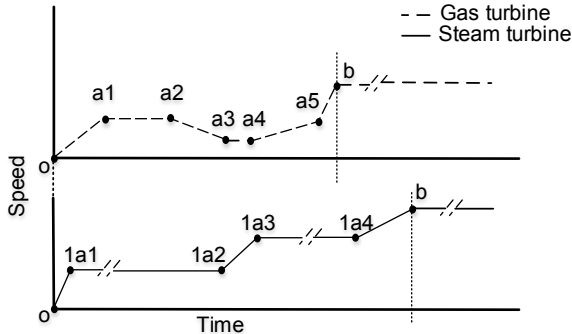

Fig.2 Start up sequence speed vs time

**D. Gas Turbine Starting Up Sequence:**

o -- a1 acceleration step using adjustable speed drive,  
a1 – a2 purging stage,  
a2 – a3 deceleration stage,  
a3 -- a4 fuel ignition stage,  
a4 – b ramp up stage to synchronous speed.

**Table 2** summaries the connected equipment status in case of line commutated inverter and variable frequency drive as starting mechanism

TABLE 2 :  
CONNECTED EQUIPMENT STATUS FOR GAS  
TURBINE START UP

Stage	Adjustable speed drive	Turbine ignition	Field excitation
o – a2	On	Off	On
a2 – a3	Off	Off	Off
a3 –a4	Off	On	Off
a4 – a5	On	On	On
a5 -- b	Off	On	On

**E. Steam Turbine generator Starting Up Sequence**

O -- 1a1 acceleration step,  
1a1 – 1a2 heating stage1,  
1a2 – 1a3 acceleration stage,  
1a3-- 1a4 heating stage 2,  
1a4 – b ramp up stage to synchronous speed.

**Table3** summarizes the connected equipment status in case of STG of two heating stages.

TABLE 3:  
CONNECTED EQUIPMENT STATUS FOR STEAM  
TURBINE START UP

Stage	Steam flow in turbine	Field excitation
o – b	On	Off
b -- onward	On	On

**F. Protection need in various operational condition**

- 1) *Field Excitation off:* Only remanence voltage available at generator terminal.
- 2) *Field Excitation and Adjustable Speed Drive On:* Terminal voltage available keeping the V/Hz constant.
- 3) *Field Excitation On and Adjustable Speed Drive Off:* Terminal voltage increases with increase of the speed.

Considering above scenario **TABLE 3** summarise the minimum protection need. Need for specific current transformer is kept out of this paper scope.

TABLE 3:  
PROTECTION NEED IN VARIOUS OPERATIONAL  
CONDITIONS

Sl.	Operation condition	Prime mover	Speed /operational steps	Protection
01	Field excitation off	Steam turbine	0.0 to 95% of nominal speed (approximately) Steps "0 – b"	Mechanical protection i.e. vibration monitoring, temperature monitoring etc.
02		Gas turbine	0.0 to few Hz Steps "a2– a4"	Mechanical protection i.e. vibration monitoring, temperature monitoring etc.
03	Field excitation and adjustable speed drive on:	Steam turbine	Not applicable	Not applicable
04		Gas turbine	Few Hz to 65.0 % of nominal speed (approximately) Steps "0 – a2" "a4 – a5"	Differential protection Over current instantaneous Ground fault** Voltage / Hz Drive mechanism protection DC link fault protection.
05	Field excitation on and adjustable speed drive off	Steam turbine	95% -105% of nominal speed. (approximately)	Standard protection
06		Gas turbine	65% -105% of nominal speed. (approximately)	Standard protection

As per TABLE 3, various protection elements require phasor quantity. In digital relay these quantities are derived from samples of fixed windows length using Discrete Fourier Transform (DFT) techniques. The fix window length is kept one cycle of nominal frequency for calculating the accurate qualities at nominal frequency. As the frequency changes, calculated phasor quantities also start varying as shown in figure3. It is observed that if the system frequency varies within +/-5% of nominal

frequency the calculated phasor magnitude varies +5.16%. As soon as frequency varies beyond this range variation also increase.

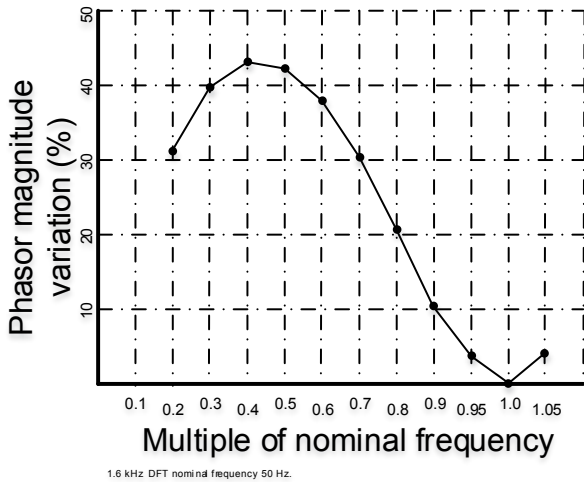

Fig. 3 Variation of phasor magnitude

GTG having the variable frequency drive only as starting mechanism, excitation is switched on within 95% to 105% of nominal frequency range. As per figure 3 within this range magnitude variation is observed approximately 5% hence use of frequency adaptiveness can improve the sensitivity of protection functions. For GTG with line commutated inverter and variable speed drive as starting mechanism, protection is needed in almost entire range of speed, hence need of frequency adaptiveness is must as error generated cannot be ignored. There are two popular methods to correct the errors. 1) Change the sampling frequency so that total no of sample is always same in one window length of running frequency. 2) Estimate the error and correct the same.

Table 5: Protection features of Generators

Depending on the rated power of the machine and on the type of application, all or some of the following protections can be used to protect the generator & unit transformer.

Data	Generator with unit transformer
Voltage	< 11 KV
Switchgear	Circuit breakers
Generator Earthing	Generator neutral earthed with high resistance and Generator transformer with secondary earthing resistor
Protections	<ul style="list-style-type: none"> <li>1. Generator differential (87G)</li> <li>2. Overall differential protection covering generator and transformer protection (87O)</li> <li>Stator overload protection (49)</li> <li>Protection against excitation faults / loss of field (40)</li> <li>Negative sequence overcurrent protection (46)</li> <li>Over current protection (51)</li> <li>Voltage restraint over current protection (51V) - alternate</li> <li>Under impedance protection (21)</li> <li>Under voltage protection (27)</li> <li>Over voltage protection (59)</li> <li>Stator earth fault protection (95% Stator Earth Fault) (64S)</li> <li>100% stator earth fault protection</li> <li>Out of step protection (78)</li> <li>Over fluxing or volts/Hertz protection (59/81 or</li> </ul>

- 24)
- Reverse power protection (32) (Only for synchronised units)
- Over frequency and under frequency protection (81O/81U)
- Frequency gradient protection (81R)
- Diode failure protection (58)
- 2 stage Rotor earth fault protection (64R) (1st stage alarm and second stage trip)
- Transformer HV REF (64) protection
- Transformer HV earth fault protection (51N) with neutral connection
- Buchholz protection
- Oil and winding temperature protection
- Pressure relief device
- Stator winding temperature alarm and trip (PTC thermistor or Pt-100 RTD). Tripping shall be as per a voting logic (2 out of 3).
- Syncho-check relay (25) (Only for synchronised units)

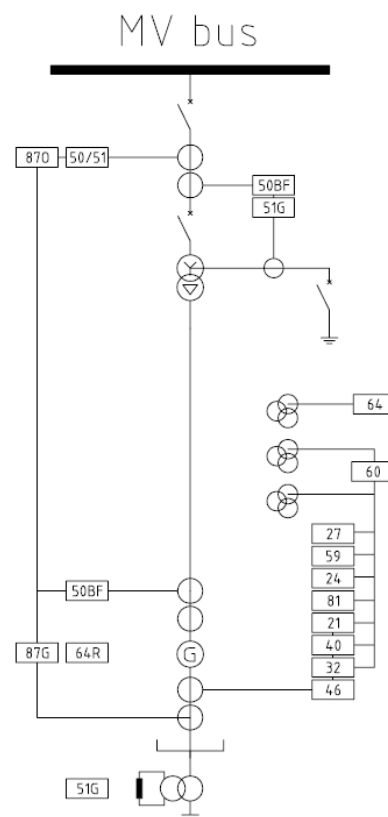

Fig. 4 Typical MV Generator Protection Single Line Diagram

#### IV. OUT OF STEP PROTECTION

Out of step protection functions detect stable power swings and out of step conditions based on the fact that the voltage/current variation during a power swing is slow compared to the step change during a fault. Both faults and power swings may cause the measured impedance to enter into the operating characteristic of a distance relay element. The apparent impedance moves from the pre-fault value to a fault value in a very short time, a few milliseconds, during a fault condition. However, the rate of change of the impedance is much

slower during a power swing or out of step condition than during a fault depending on the slip frequency of the out of step. The impedance measurement should not be used by itself to distinguish between a fault condition and an out of step condition from a phase fault. The fundamental method for discriminating between faults and power swings is to track the rate of change of the measured impedance.

The function measures the rate of change of the impedance using two impedance measurement elements known as blinders together with a timing device. If the measured impedance stays between the blinders for a predetermined time, the function declares a power swing condition and asserts an output that can be used to block the distance protection. However, if the impedance passes the inner blinder and exits on the other side of the mho characteristics (that is, the resistive component of impedance has opposite sign as at the time of point of entry) an out of step operate is issued by the function. Figure 5 gives an example of out of step detection.

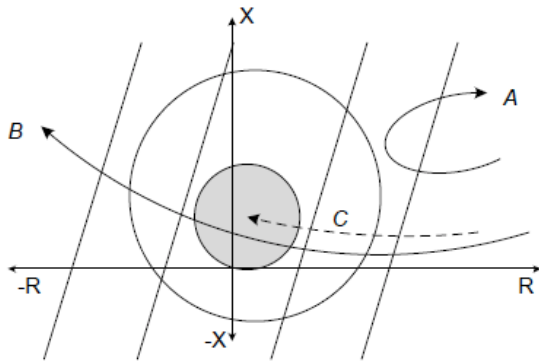

Fig. 5 Example of out of step detection

The shaded region indicates a fault zone in a distance protection function. For curve A, the impedance moves into the out of step zone and leaves slowly, indicating the occurrence of a swing that quickly stabilizes. For curve B, the impedance moves slowly into the out of step zone and exits the zone indicating that the network is becoming unstable. For curve C, impedance rapidly moves into, and remains in, the fault zone indicating an actual fault and not an out of step condition.

## V. AUTO SYNCHRONISATION

Traditionally, generator control systems include a synchronizing panel. The synchronizing panel includes indications of voltage, angle, and slip that show what adjustments the operator needs to make to the governor and exciter and when it is acceptable for the operator to close the breaker. In many cases, the process is automated using an automatic synchronizer with manual control available as a backup.

### A. Auto synchronizer controls as a part of integrated multifunction protection relay:

The primary task of a protection relay is certainly to perform the assigned protection tasks. Additional

protection relay duties are typically related to measurement and control functionalities. The control functions normally include, as a minimum, the control of a primary (fault) current switching capable device i.e. a circuit breaker (here after referred as CB) or a contactor. With a generator, the closing of the CB has been traditionally controlled by other devices than the protection relay. The synchronized closing of the CB is controlled by a dedicated auto synchronizer (here after referred as AS) device. This solution is typically backed-up with manual controls together with double frequency and voltage meters; and a synchronous scope with Synchrocheck functionality.

This paper explains a new approach, where the protection relay could combine the protection functionality with the features of an AS device and manual back-up controls. The protection relay, via its' protection duties, has already most of the necessary information available to be able to determine the correct conditions for the CB close command. Connections for the protection relay to control the generator output quantities, voltage and frequency, are added. Also information of Governor and AVR mode statuses are wired to the protection relay.

To carry out a single generator synchronizing as a stand-alone activity by the protection relay is a quite straight forward operation. Typically this not enough for the plant needs, the selected non-generator CBs will have to be synchronized as well. In a traditional solution this means a lot wiring and use of additional auxiliary relays to implement a complete AS system. Such a system is vulnerable and possible faults surface typically only when the functionality is needed. By introducing binary and analogue GOOSE signaling over the station bus as per IEC 61850 for the complete AS system, the communication between protection relays is supervised and hardwired connections are reduced to a minimum. The availability of the AS system is considerably improved due to reduced number of components and supervised IEC 61850 GOOSE communication. The selected protection relays within the system communicate with each other to enable coordinated synchronization of the key non-generator breakers, like bus couplers and bus sectionalizers.

### B. Human Machine Interface (HMI)

Compared to the traditional approach, the protection relay based AS system supports both manual and automatic synchronization of the generator. In addition, a semi-automatic synchronization mode is introduced to enable full system performance validation with operator confirmed closing of the CB. The graphical display of the protection relay is also used to fully visualize the traditional synchronous scope typically used during manual synchronizing of the generator. The local HMI also serves for monitoring the status of the generator post synchronisation.

Depending on the selected process control system and its' architecture, the remote control of the auto synchronization of generators could be very similar to the local control features described above. However as a minimum, the initialization of automatic synchronization sequence for a selected generator shall be considered.

### C. Control interfaces towards generator AVR and prime mover governor

As mentioned earlier, the protection relay have to receive information and send control commands to the generator's AVR and prime mover's Governor. The traditional solution is to use hardwiring between the mentioned devices and the relay. Depending on the location of the AVR and the Governor, the wiring distance can be rather long. An alternative is to install a remote I/O (RIO) interface box close by the AVR and the Governor. This RIO box interfaces with the relay using GOOSE signaling as per IEC 61850. The communication media between the relay and the RIO box (es) utilizes optical Ethernet. The optical media guarantees interference free communication in an EMC harsh environment. The same RIO box transfers RTD or mA based measurements to the protection relay, to be used by the protection functions requiring such measurement data.

### D. Benefits achieved with redundant protection relay approach

If the chosen approach with generator protection is to go for a full redundant (main1 and main2) solution, this approach can have continuation on the AS side as well. As noted earlier, the conventional back-up solution for the AS is to rely on the fully manual operation, external to the dedicated AS device. With the proposed protection relay driven AS solution, the full redundancy is achieved. The AS1 (as a part of main 1 relay functions) is the responsible one during normal operation conditions. In case the main 1 relay is not operational, the information is received by the main 2 relay. As a result of this the AS2 (as a part of main 2 relay functions) is unblocked and takes over the synchronizing of the generator. All of the AS modes presented above are available even one protection relay (main1 or main2) is out of operation.

## VI. CONCLUSIONS

Usage of modern multifunction generator protection relay with redundant approach (main-1+ main-2) would greatly enhance the overall availability and reliability of generator protection for critical generators applied in petroleum and chemical industry. Further the frequency adaptiveness of protective functions ensures availability the critical protections during the start-up sequence of GTGs when VSD is used for starting the turbine. Protection could be achieved with utmost sensitivity. Integrating auto synchronizer into protection relays would provide redundancy for generator synchronizing and opens up new communication based possibilities for establishing an installation wide supervised auto synchronizing system.

## VII. ACKNOWLEDGEMENTS

The authors would like to acknowledge their sincere gratitude to the ABB and SHELL management for their permission and support granted with preparation of this paper. Also we would like to thank ABB colleagues Joakim Nilsson, Timo-Latva-Kiskola, Bruno Sousa who contributed with their inputs, review and comments during

the preparation of this paper and their contribution is acknowledged.

## VIII. REFERENCES

- [1] Working group J-2 of the Rotating Machine subcommittee, "Protection Considerations for Combustion Gas Turbine Static Starting"
- [2] IEEE PSRC, WG I 19, Redundancy Considerations for Protective Relaying Systems, version 1, March 6, 2007.
- [3] IEEE Guide for AC Generator Protection\_C37.102
- [4] Protection Criterion for Medium Voltage Networks TG\_MV-Protection (EN) - \_1VCP000280

## IX. VITA

**Prashant Ganoo** graduated from the Maharaja Sayajirao University of Baroda, Vadodara, India in 1986 with Bachelor of Engineering (Electrical) degree. He also attended 6 months residential Management Programme for Technologists at the Indian Institute of Management, Bangalore. He has been with ABB since 1986 and has worked at India, Malaysia and Finland and is presently working as product line manager at ABB Vaasa, Finland. [prashant.ganoo@fi.abb.com](mailto:prashant.ganoo@fi.abb.com)

**Olli Rintamaki** graduated from the Vaasa University of Applied Science, Finland in 1986 a BScEE degree. Presently working as product line manager at ABB Finland. [Olli.rintamaki@fi.abb.com](mailto:Olli.rintamaki@fi.abb.com)

**Sharad Dwivedi (CEng, MIET)** graduated from Kamla Nehru Institute of Technology, Sultanpur in 1991 with an honors degree in Electrical engineering. He has worked with Indian Petrochemicals and Reliance group in India. He is working with Shell Global Solutions International B.V. since 2007 as Senior Electrical Engineer. [sharad.dwivedi@shell.com](mailto:sharad.dwivedi@shell.com)

**Arinjai Gupta** graduated from Motilal Nehru National Institute of Technology, Allahabad in 1996 in electrical engineering. Presently working as principal engineer at ABB, India. He has co-authored four paper and two granted patents. [arinjai.gupta@in.abb.com](mailto:arinjai.gupta@in.abb.com)