

Effective: January 1988
Supersedes I.L. 41-552.1N, Dated April 1978

⊕ Denotes Change Since Previous Issue

Type DT-3 Temperature and Micron Relay



Before putting protective relays into service, remove all blocking which may have been inserted for the purpose of securing the parts during shipment, make sure that all moving parts operate freely, inspect the contacts to see that they are clean and close properly, and operate the relay to check the setting and electrical connections. Note that movement and frame may be energized and dangerous to touch.

APPLICATION

The principal application of the type DT-3 relay is for protection against excessive temperature in electrical machines through response to changes in resistance of an exploring coil installed in the protected apparatus. The relay may be used for protecting transformers and either ac or dc generators and motors from damage resulting from abnormally high temperatures. The point at which the relay contacts close is adjustable along a scale calibrated in degrees Celsius. The operation of the relay contacts may be used to open the circuit breaker, sound an alarm, start blowers, or take care of the high temperature in any desired manner. The DT-3 relay may be supplied for ac or dc operation. A modified form of the DT-3 relay is used as part of a vacuum measuring device and has a scale calibrated in microns.

The type DT-3 relay has a permanent magnet field, and consequently it is free from the variations in operating point that would result from fluctuations in the voltage source if an electromagnet field were used.

The DT-3 is normally used with an external 10 ohm 25°C copper resistance temperature detector (RTD). Some type DT-3 relays are available for use with a 120 ohm 0°C nickel RTD as well as a 100 ohm 0°C platinum RTD.

Temperature Sensor (RTD) Guide

The amount of current that circulates through the RTD depends on the resistance of the RTD and the temperature range of a particular DT-3.

For example, a 10 ohm copper RTD with a 60 to 120°C scale will circulate approximately 90 milliamperes. A 50 to 190°C scale will cause 40mA to flow through the RTD.

The 100 to 160°C range DT-3 for use with the 120 ohm nickel RTD circulates 17mA while the 50 to 190°C type will send 8mA through the RTD.

Approximately 15mA will be seen by the 100 ohm platinum RTD for the 50-190°C relay.

The resistance temperature detector therefore should be sized so that the self-heat error will be limited to 1% or less. For instance, the use of a .050" thick stick type Platinum RTD from MINCO Co. will have a resistance change much less than 1% with 15mA flowing through it.

The DT-3 relays for use with 100 ohm platinum RTD are calibrated to the U.S. Lab Specification ($R_{100^{\circ}\text{C}}/R_{0^{\circ}\text{C}} = 1.3926$) corresponding to MINCO Co. resistance-

All possible contingencies which may arise during installation, operation or maintenance, and all details and variations of this equipment do not purport to be covered by these instructions. If further information is desired by purchaser regarding this particular installation, operation or maintenance of this equipment, the local ABB representative should be contacted.

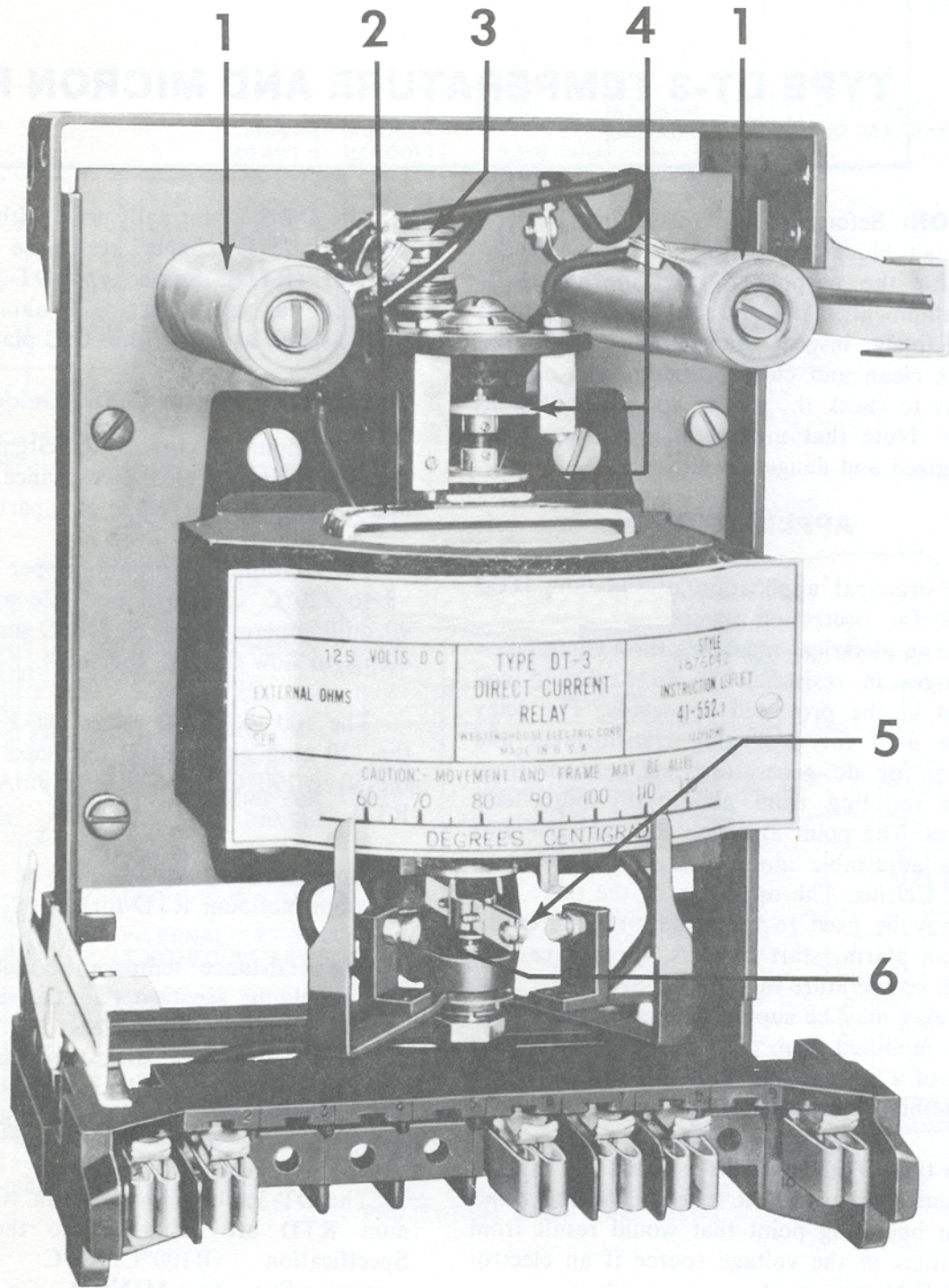

★ Fig. 1a. D.C. Type DT-3 Temperature Relay without Case. 1-Internal Series Resistor. 2-Moving Coil. 3-Bridge Resistor. 4-Current carrying Counter Wound Restraining Springs. 5-Moving Contact. 6-Stationary Contacts.

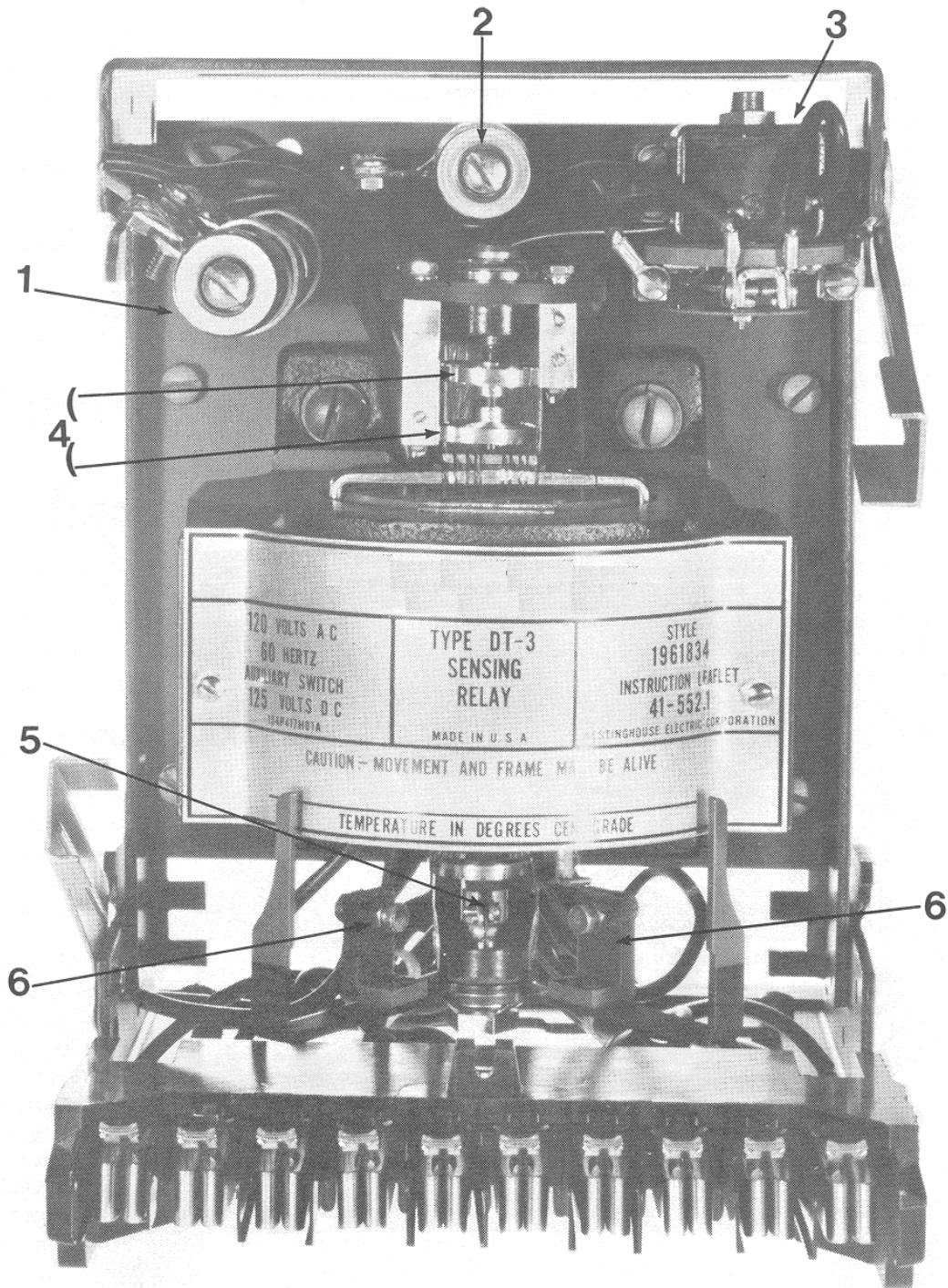

* Fig. 1b. Uncalibrated AC Type DT-3 Temperature Relay without case (Front View). 1-Two adjustable resistors. 2-Control fixed resistor. 3-Control CS-1 contactor switch. 4-Current carrying counter wound Restraining Springs. 5-Moving contact. 6-Stationary contact.

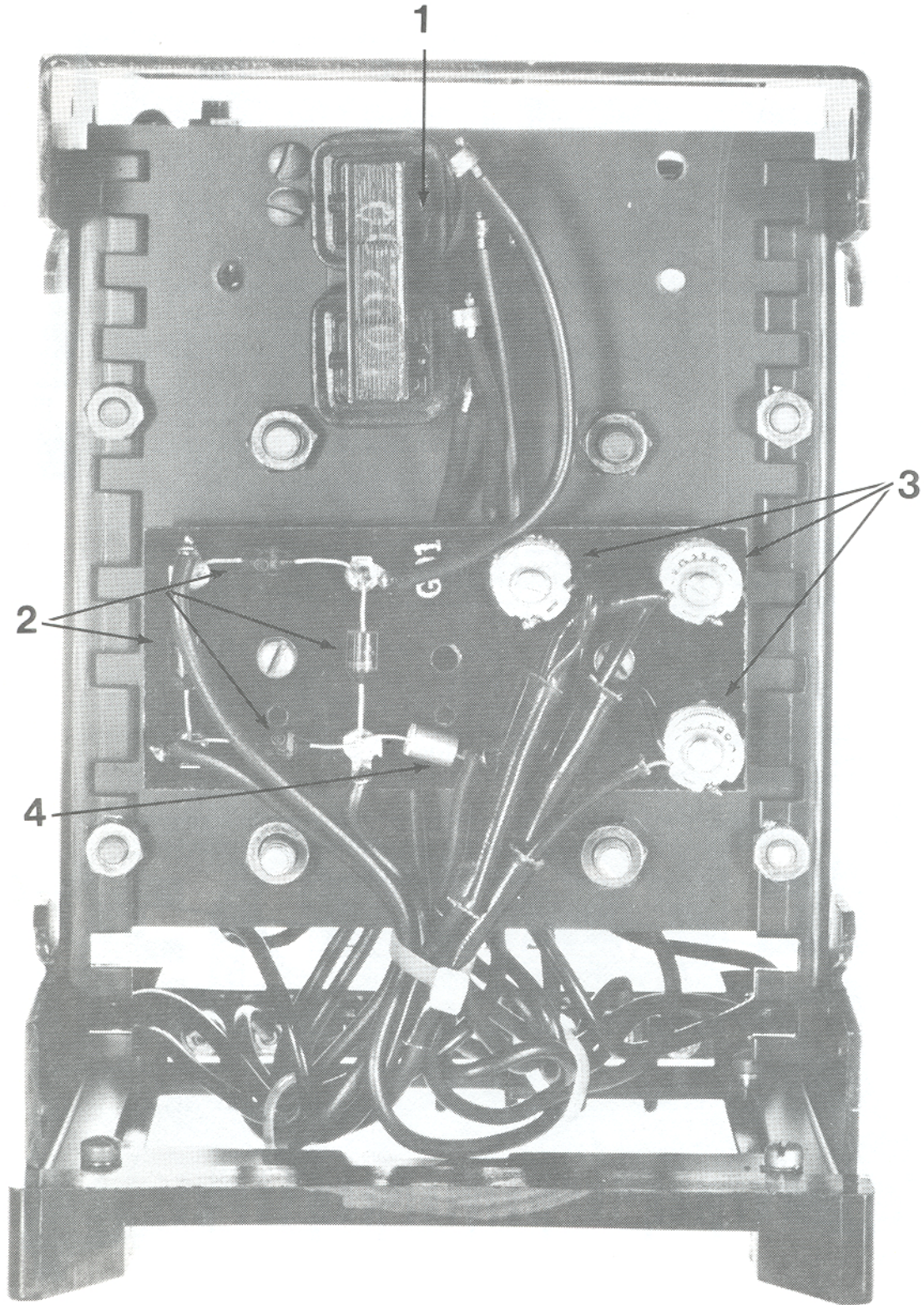

Fig. 1c. Uncalibrated AC Type DT-3 Temperature Relay without case. (Rear View). 1-Transformer. 2-Rectifier. 3-Three fixed resistors. 4-Voltage Regulator.

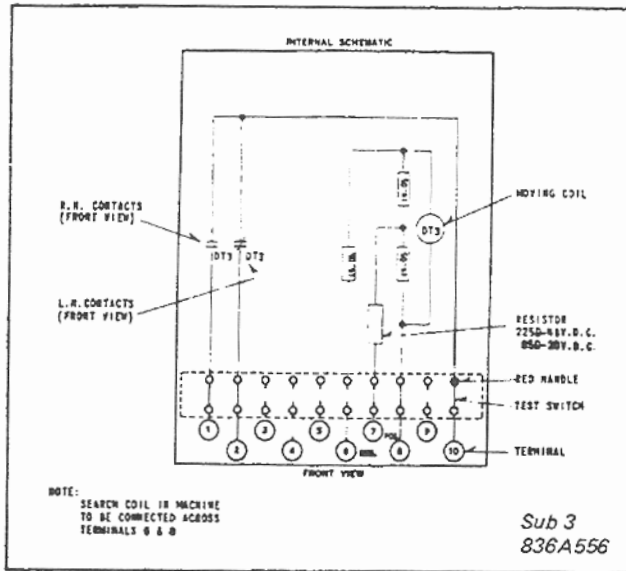

Fig. 2. Relay Type DT-3 Temperature S.P.D.T. Contacts in Type FT21 Case - 100 to 160°C Temperature Range.

temperature table number 1-100. However the differences between this specification and others such as the European and Canadian are slight and RTDS manufactured to these specifications may be used with the DT-3 relay.

CONSTRUCTION AND OPERATION

The type DT-3 relay is a d'Arsonval type dc contact making milliammeter. The magnetic circuit is shown schematically in Fig. 12. A cylindrical core, consisting of an Alnico permanent magnet, two iron pole pieces and two brass spacer blocks, is mounted concentrically in the bore of a malleable iron frame casting. The moving coil rotates in the air gap between the core and the frame casting. A Moldarta bracket mounted on the rear of the core carries bearings for the frame on which the moving coil is wound, and also provides connection points for the spiral/springs through which electrical connection is made to the moving contact and the moving coil. The two springs which are connected to the moving coil are located at the top of the element. The outer ends of these springs are fastened to posts mounted in a circular insulating plate. This plate is mounted on the Moldarta bracket by means of the upper bearing screw and a spring washer, so that it is held in position securely, but yet can be rotated to permit adjustment of the zero position of the moving element.

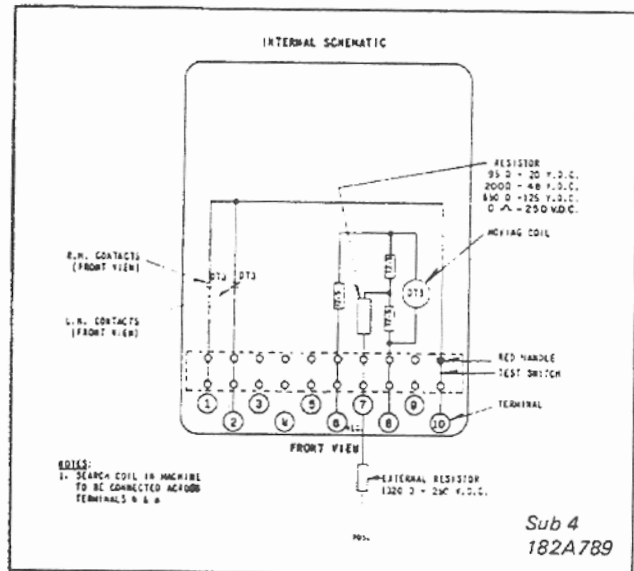

Fig. 3. Internal Schematic of the 60-120°SPDT Type DT-3 Temperature Relay in the Type FT21 Case.

The moving contact is mounted to the outer end of a counterbalanced arm fastened to the bottom of the moving coil shaft. Current is introduced into this contact by the third spiral spring. On either side, a stationary contact arm is fastened to the frame. Each of these stationary contacts is adjustable in a small arc and an upright guide arm indicated its position relative to a calibrated scale on the lower part of the nameplate. Relays for certain special applications are provided with a pointer, which is fastened to the contact arm and moves in front of the calibrated scale.

A screw containing a sapphire thrust bearing and a ring guide bearing is mounted in the lower bearing support of the moving element. The inverted position of this bearing screw prevents dirt particles from falling into it. A guide bearing only is provided at the top of the moving element, but the bearing pin is the lower of the two bearing members here also.

The type DT-3 temperature relay is supplied with a self-contained bridge. As shown in Figs. 7 and 8, the connections take the form of a Wheatstone bridge composed of three fixed resistors and the search or exploring coil, with the moving coil of the relay connected across the center of the bridge.

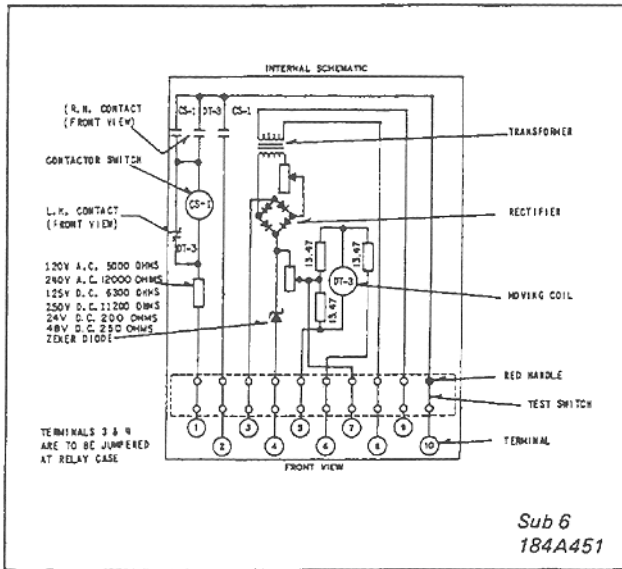

Fig. 4. Internal Schematic of the AC Type DT-3 Temperature Relay in the Type FT21 Case.

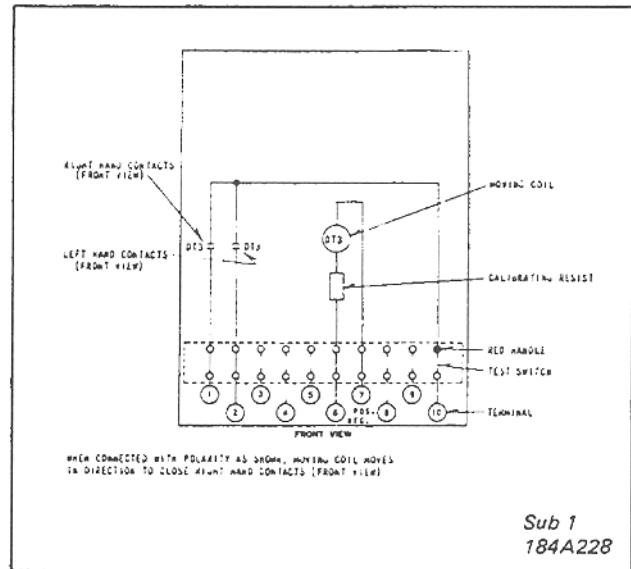

Fig. 5. Internal Schematic of the Type DT-3 Pirani Gage (Vacuum Measuring) Relay in the Type FT21 Case.

The ac type DT-3 temperature relay consists of a transformer, rectifier, voltage regulator, three fixed resistors, two adjustable resistors, contactor switch, and a d'Arsonval type d c contact making milliammeter. For changes of ± 10 percent in the supply voltage, only a small change occurs in voltage across the bridge.

TRIP CIRCUIT

contacts	dc control voltage	amperes contacts will: (non-inductive load)		
		open	close	carry continuously (CS-1)
DT-3 relay	125 v 250 v	0.04 ♦ 0.02 ♦	1.0 1.0
CS-1 contact switch (when supplied)	125 v 250 v	3.5 1.0	30 30	5.0 5.0

♦ infrequent operation

In Fig. 7 and 8 the high-temperature contact is immediately by-passed by a contact of the auxiliary relay when the latter picks up, and when the auxiliary relay is dropped out by the low temperature contact of the DT-3 relay the circuit is interrupted by the same contact of the auxiliary relay.

CS-1 Contactor Switch

The dc contactor switch in the relay is a small solenoid type switch. A cylindrical plunger with a silver disc mounted on its lower end moves in the core of the solenoid. As the plunger travels upward, the disc bridges three silver stationary contacts. The coil is in series with the high temperature contact of the relay. The low temperature contacts of the relay shunt the contactor switch coil. When the temperature of the protected apparatus, reaches the setting of the relay, the coil of the contactor switch is energized and closes the switch contacts. One contact of the switch seals-in around the high temperature contact of the DT-3 relay. Another contact of the switch sounds an alarm or trips a breaker. When the temperature of the protected apparatus decreases to the low temperature setting of the relay, the contacts of the relay shorts the coil of the contactor switch to cause the switch to dropout. Relays with an ac contactor switch (CS-1) are available for use on 120 or 240 V ac rated supplies. An operation indicator can also be supplied.

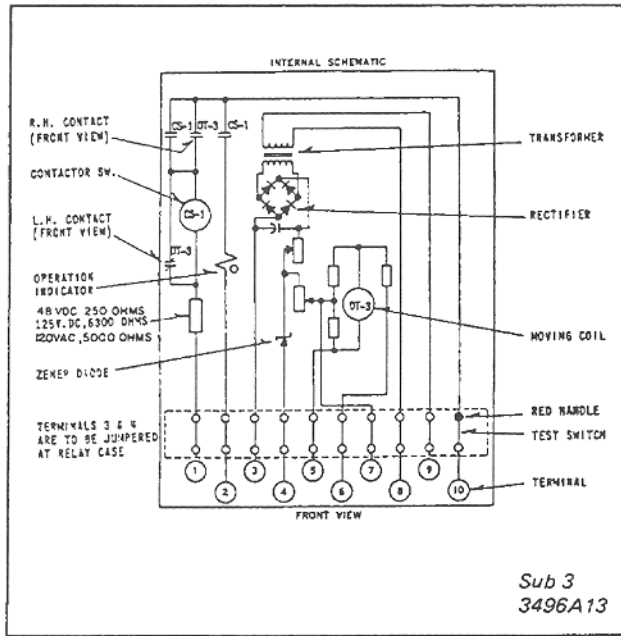

Fig. 6. Internal Schematic of the DT-3 Relay for use with 120 ohm 0°C nickel RTD with operation indicator.

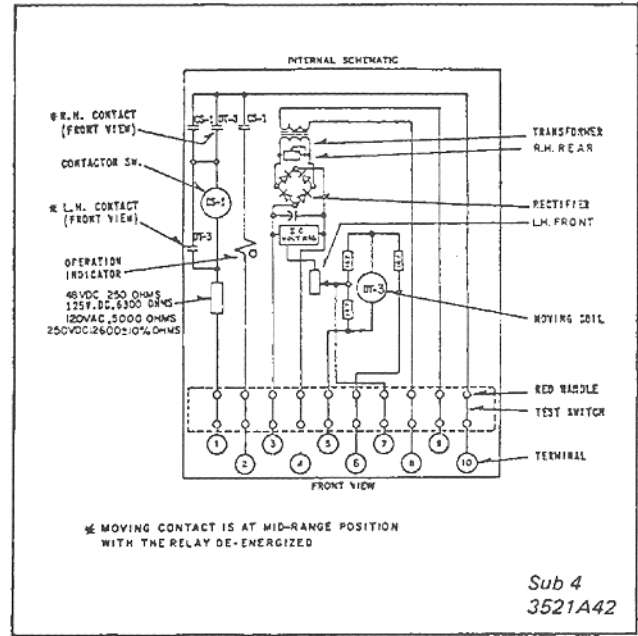

Fig. 6A. Internal Schematic of the DT-3 Relay for use with 100 ohm 0°C platinum RTD with operation indicator.

CHARACTERISTICS AND SETTINGS

Type DT-3 Relay for Temperature Measurement

The dc type DT-3 relay is available in the temperature ranges listed below. It has a moving coil resistance of approximately 15 ohms at 25°C. The ac type has a scale calibrated from 50 to 190 degrees Celsius. The moving coil resistance is 90 ohms for the nickel and platinum type DT-3.

Temperature range	60 - 120°C
	60 - 140
	100 - 160
	50 - 190

The right-hand (front-view) stationary contact can be set so that a circuit is closed at and above any search coil temperature within the calibrated range of the relay. Similarly, the left-hand stationary contact can be set so that a second circuit is closed at and below any temperature less than the setting of the right-hand contact.

The standard dc relay is designed for operation with a 10 ohm copper exploring coil, and is calibrated for a range of settings from 60°C. to 120°C. The moving element is arranged so that the contacts stand at the 90°C. position when there is

no current in the moving coil. The resistors forming the three fixed legs of the bridge are adjusted to a value of 12.50 ohms, which is the resistance at

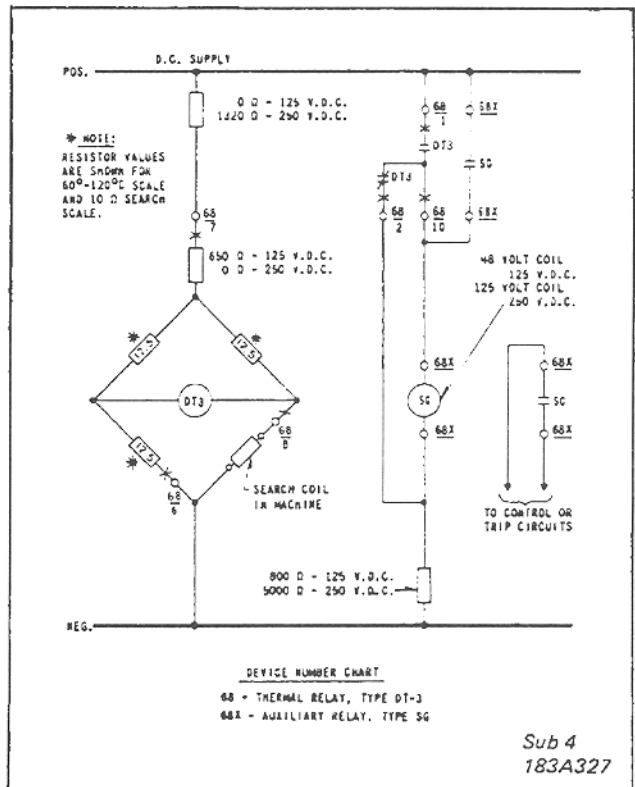

Fig. 7. External Schematic Diagram for Thermal Protection of Electrical Equipment using the DC Type DT-3 Temperature Relay in the Type FT21 Case.

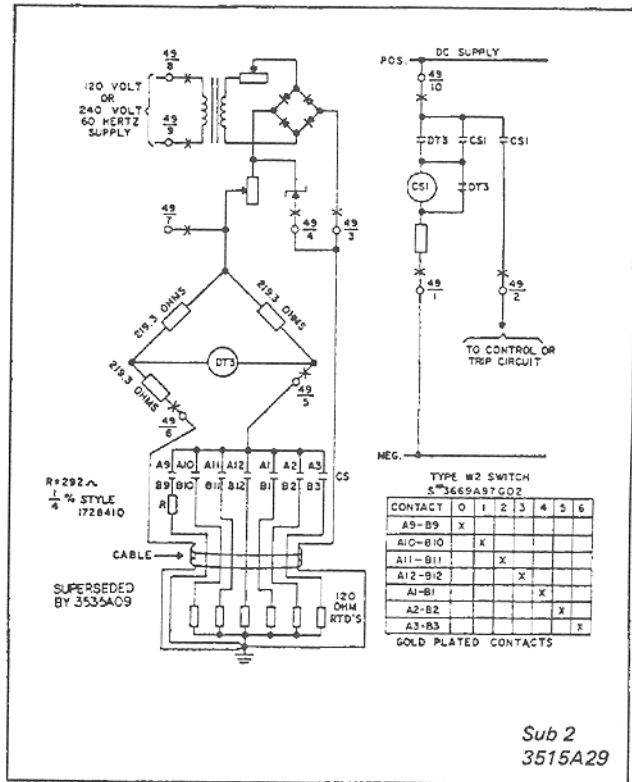
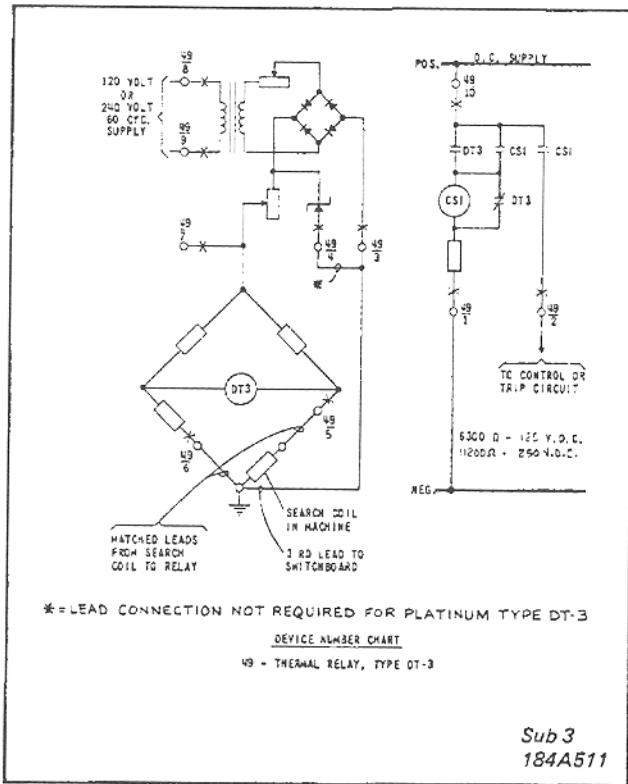

Fig. 8. External Schematic Diagram for Thermal Protection of Electrical Equipment using the AC Type DT-3 Temperature Relay in the Type FT21 Case.

Fig. 8A. External Schematic for Thermal Protection of Electrical Equipment using AC Type DT-3 Temperature Relay with 6 (120 ohm) RTDs, test resistor and selector switch in Type FT21 case.

90°C. of a copper search coil which measures 10 ohms at 25°C. When the bridge circuit is energized, the current in the moving coil, and the resulting torque, will be in one direction or the other, depending upon whether the search coil temperature is above or below 90°C., and the contacts will move to the position where the electrical torque is balanced by the restraining torque of the control springs. Other ranges available are shown on page 7.

A DT-3 for use with a 120 ohm nickel sensor is available as well as a 100 ohm platinum sensor.

The moving contact is at mid-range position with the relay de-energized. The left-hand or right-hand contact may be closed under this condition depending on the temperature setting.

On the standard 10 ohm copper 50 to 190°C ac type DT-3 relay, the mechanical balance point is at approximately 115°C.

The 60 hertz burden of the ac type DT-3 relay at rated voltage is 5.9 volt-amperes, and will continuously stand 110% of rated voltage. The operate range is from 90 to 110% of rated voltage.

Type DT-3 Relay with Micron Scale

A special form of the type DT-3 relay used as part of a vacuum-measuring device is calibrated in microns. It has a moving coil with a resistance of approximately 90 ohms, and sufficient resistance is connected in series with the moving coil internally to increase the resistance measured across the relay terminals, to 100 ohms. This relay has a pointer which indicates the moving contact position on the calibrated scale. The standard relay has a scale calibrated from 0 to 30 microns.

INSTALLATION

The relays should be mounted on switchboard panels or their equivalent in a location free from dirt, moisture, excessive vibration and heat. Mount the relay vertically by means of the rear mounting stud or studs for the type FT projection

case or by means of the four mounting holes on the flange for the semi-flush type FT case. Either the stud or the mounting screws may be utilized for grounding the relay. External toothed washers are provided for use in the locations shown on the outline and drilling plan to facilitate making a good electrical connection between the relay case, its mounting screws or studs, and the relay panel. Ground Wires are affixed to the mounting screws or studs as required for poorly grounded or insulating panels. Other electrical connections may be made directly to the terminals by means of screws for steel panel mounting or to the terminal stud furnished with the relay for thick panel mounting. The terminal stud may be easily removed or inserted by locking two nuts on the stud and then turning the proper nut with a wrench.

For detail information on the FT case refer to I.L. 41-076.

The ambient temperature at the type DT-3 relay has no appreciable effect on its operation. The ambient temperature will affect the resistance of the leads to the search coil. By connecting one side of the supply directly to the search coil and then to the relay terminal, the search coil lead resistance is added to both sides of the bridge and thus the variation of lead resistance is thus substantially balanced out. It might be more convenient in some cases to connect the bridge directly to the source, instead of running one supply lead to a search coil terminal at the machine. This can be done if the search coil leads are short or have a total resistance less than about 0.25 ohms. Such a lead resistance would cause the dc relay contacts to close when the search coil was 6.5°C. below the relay temperature setting, but this error can be compensated largely by adjusting the relay setting accordingly.

ADJUSTMENTS AND MAINTENANCE

The proper adjustments to insure correct operation of the relay have been made at the factory and should not be disturbed after receipt by the customer. If the adjustments have been changed, the relay taken apart for repairs, or if it is desired to check the adjustments at regular maintenance periods, the instructions below should be followed.

All contacts should be periodically cleaned. A contact burnisher S#182A836H01 is recommended for this purpose. The use of abrasive material for cleaning contacts is not recommended because of the danger of embedding small particles in the face of the soft silver and thus impairing the contact.

If the moving element should be removed, the bearing end-play should be checked when replacing it. This should be from .020 inch to .025 inch, and can be measured by inserting a feeler gauge between the upper bearing screw and the shoulder on the moving element shaft.

In case it should be desirable to check the calibration of the type DT-3 relay, this can be conveniently done by substituting a variable resistor for the search coil. Any scale point can be checked by setting the resistor for the corresponding resistance, as indicated in the tables below, and seeing that the moving contacts travel to the indicated scale position. The relay should be energized at normal voltage for the test, and all other connections should be made as shown in Fig. 9 for dc relays, and Fig. 10 for ac relays.

RESISTANCE VS. TEMPERATURE TABLE

Temperature Degrees Celsius	Resistance Ohms (10 ohm 25°C copper RTD)	Resistance Ohms (120 ohm 0°C nickel RTD)	Resistance Ohms (100 ohm 0°C platinum RTD)
50°	10.96	157.7	119.8
60°	11.35	165.9	123.7
70°	11.73	174.3	127.6
80°	12.12	182.4	131.5
90°	12.50	191.6	135.4
100°	12.89	200.6	139.3
110°	13.28	209.9	143.1
120°	13.66	219.3	147.0
130°	14.05	229.0	150.8
140°	14.43	238.9	154.6
150°	14.82	249.0	158.5
160°	15.20	259.3	162.3
170°	15.59	269.9	166.1
180°	15.97	280.8	169.8
190°	16.36	292.0	173.6

The core and moving coil assembly should not be removed from the frame casting of the DT-3 relay unless a keeper having the same radius on the core is placed on the core in such manner as to

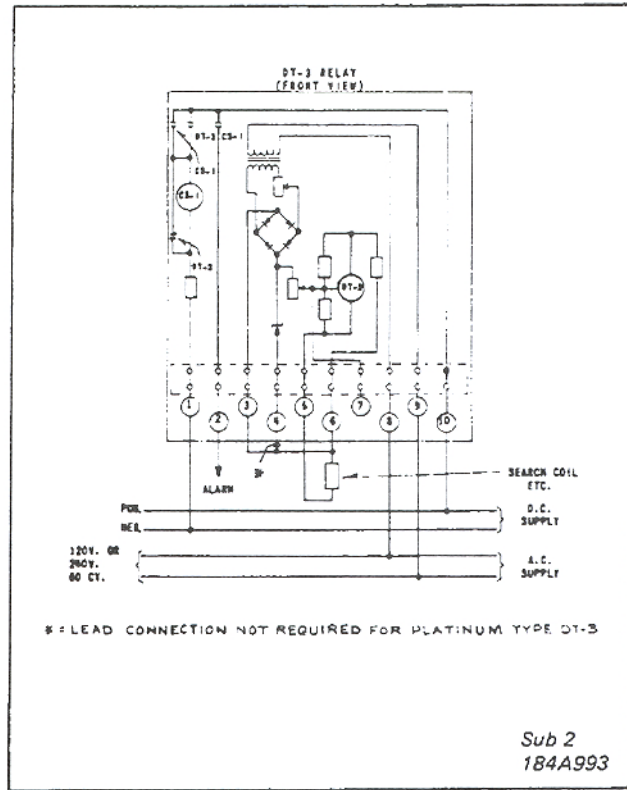
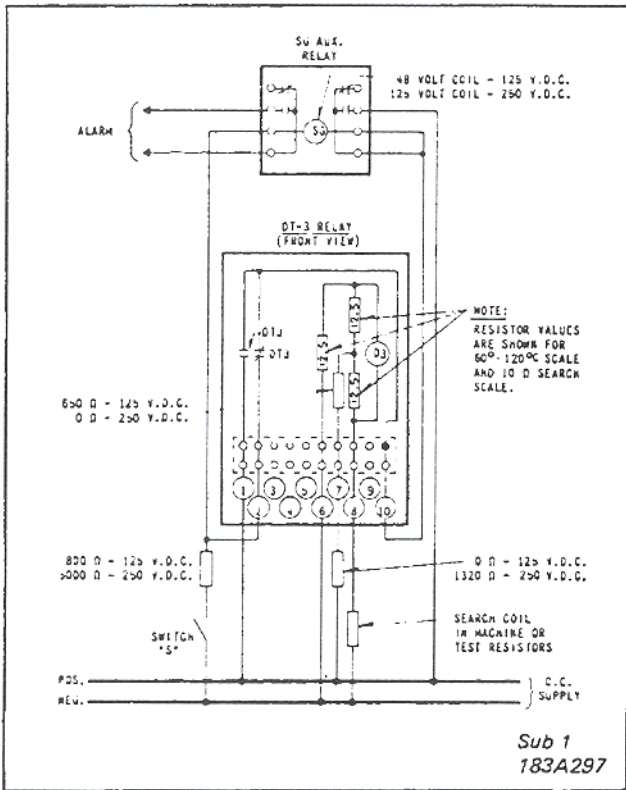

Fig. 9. Diagram of Test Connections for the DC Type DT-3 Temperature Relay in the Type FT21 Case.

Fig. 10. Diagram of Test Connections for the AC Type DT-3 Temperature Relay in the Type FT21 Case.

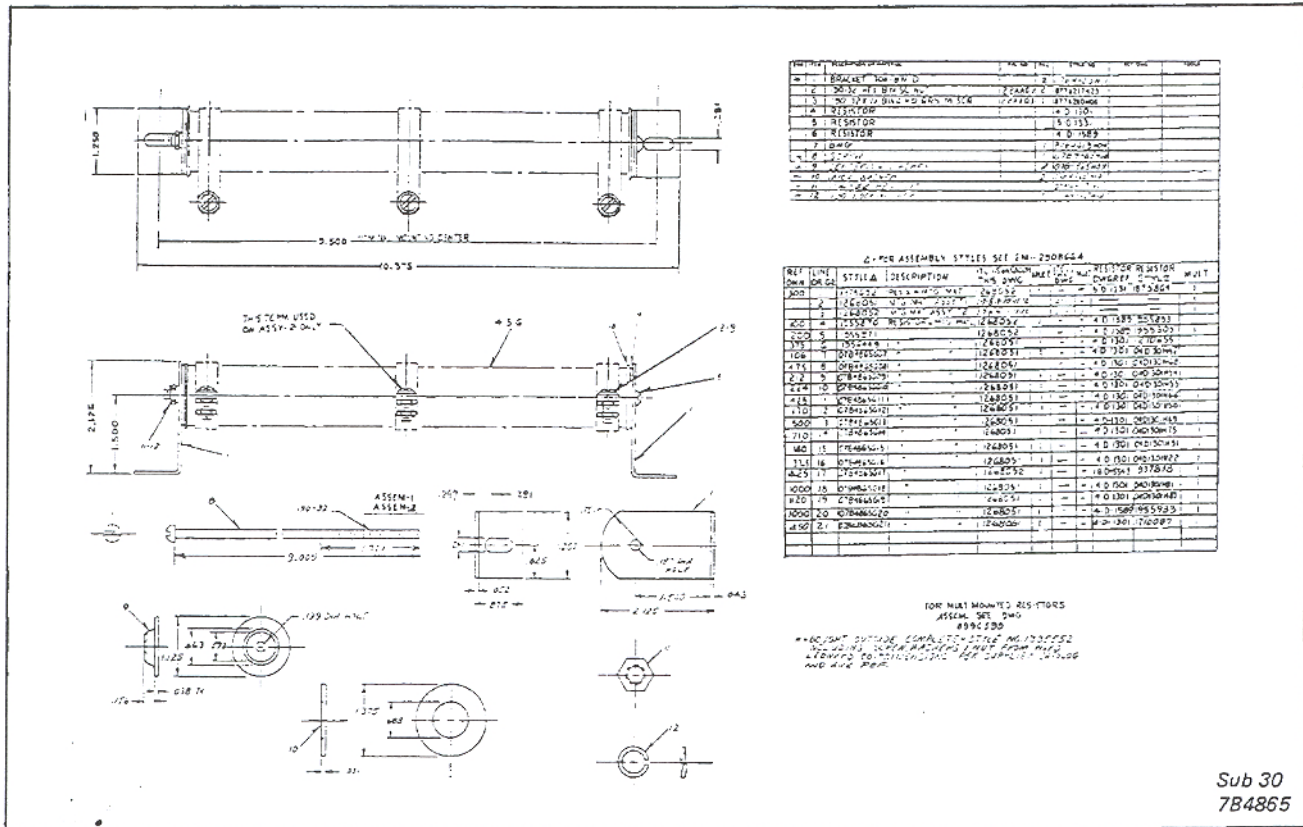

Fig. 11 Outline and Drilling Plan for External Resistor used with 250 V.D.C. Type DT-3 Temperature Relay.

bridge the iron pole pieces as the core is withdrawn from the bore of the casting. It is necessary also to insert spacers in the air gap so that the core will remain approximately centered when the mounting screws are removed, to prevent damaging the coil winding when sliding the assembly out of the casting. The factory assembly is made before the magnet has been magnetized, and the complete assembly is placed between the poles of a magnetizer which produces a field sufficiently strong to saturate both the magnet and the frame casting. This avoids the necessity of using magnet keepers and simplifies the assembly.

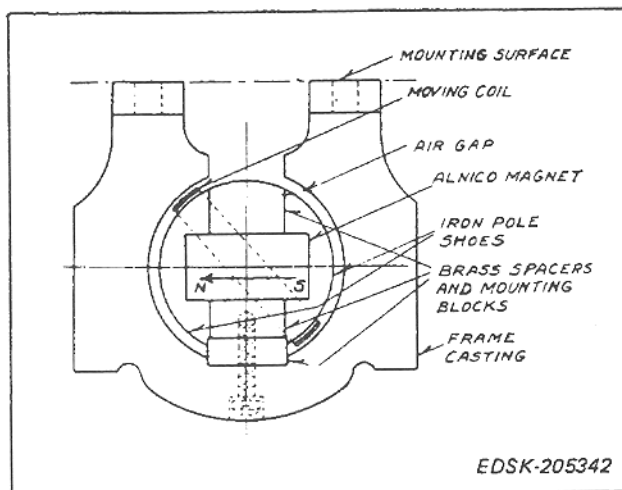

Fig. 12. Schematic Drawing of Magnetic Circuit of Type DT-3 Relay (Top View). Moving Coil Bearing Supports, Springs and Contacts Omitted.

Operation Indicator

The operation indicator (when used) consists of a small solenoid coil mounted in a steel frame, a spring restrained armature and a white flag. The indicator is reset by a push rod in the cover. Block the CS-1 auxiliary relay contacts closed and pass 0.2 amperes ac or dc through the indicator. The white target should fall into view.

The coil has a resistance of approximately 2.8 ohms and a continuous current carrying capacity of 0.6 amperes.

REPAIRS AND RENEWAL PARTS

Repair work can be done most satisfactorily at the factory. However, interchangeable parts can be furnished to the customers who are equipped for doing repair work. When ordering parts, always give the complete nameplate data.

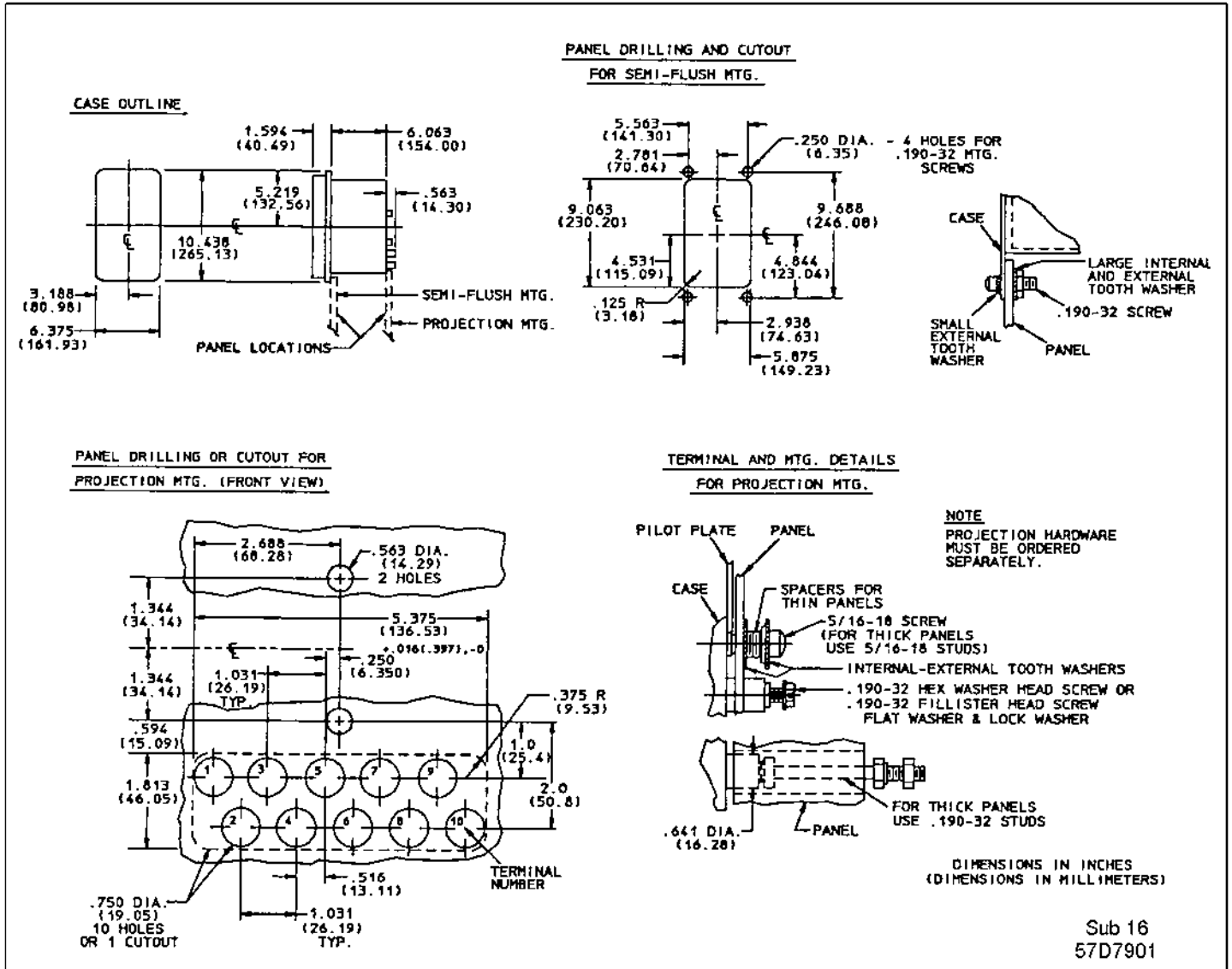

Fig. 13. Outline and Drilling Plan for the Type DT-3 Relay in the Type FT21 Case.



ABB Inc.

4300 Coral Ridge Drive
Coral Springs, Florida 33065

Telephone: +1 954-752-6700

Fax: +1 954-345-5329

www.abb.com/substation automation