

In wastewater applications, measurement is made at either the treatment works discharge and/or at the de-phosphatisation stage (if installed) to monitor or control this particular process.

Monitoring at either of these two points is used to confirm the correct operation of the plant and monitor compliance with discharge consent limits.

## Why use a Phosphate Monitor

- ▶ To monitor the performance of the wastewater plant (and de-phosphatisation process if fitted).
- ▶ It gives immediate indication if required discharge consent limits are being exceeded.
- ▶ Analysis of phosphate concentration in the laboratory is a time consuming task.

Samples must be collected, stored, delivered and possibly stored again before a laboratory colorimetric analysis is made, this analysis itself taking some 10 minutes.

On-line analysis offers a simple, convenient, low cost solution.

- ▶ An on-line Phosphate monitor continuously monitors (and if required controls) plant performance, to ensure compliance with current legislation.

## Why use ABB Instrumentation?

- ▶ Proven reliability and low maintenance requirements.
- ▶ The model 8242 is a continuous on-line monitor – not a batch type analyser.
- ▶ Sample read-out updated every 1 minute.
- ▶ Uses a single reagent – low ongoing reagent/operating costs.
- ▶ Manual intervention is reduced to only four-weekly reagent replenishment and a twelve-monthly service, guaranteed through the use of specially developed long life pump tubing.
- ▶ Single consumable spares kit, included with the monitor, includes all spares and peripherals necessary for two years operation – no hidden extras.
- ▶ Full installation, commissioning and routine servicing is available.

## What ABB Products are Suitable?

- ▶ **Model 8242 Phosphate Monitor**
  - Continuous sample reaction ensures optimum speed of response,
  - Fully dynamic chemical mixing guarantees complete chemical reaction,
  - Unique heated block assembly maintains full temperature control over the chemical reaction and optical measurement system,
  - Measurement is fully temperature controlled and takes place at completion of the chemical reaction, ensuring accurate reproducible performance at varying sample and ambient temperatures,
  - Fully automatic two-point calibration confirms no error due to chemical drift,
  - Comprehensive on-board diagnostics monitor performance parameters.
- ▶ **Model 9381 Ultrafilter**
  - This is optional and only required if the suspended solids concentration in the sample  $>10\text{mg/l}^{-1}$  and/or  $<60\text{microns}$ .
  - Sample requirements:
    - minimum pressure 1.5 bar,
    - minimum sample flowrate 70 litre/minute,
    - the sample delivery pump must be capable of this duty.

## Associated ABB Products for use on Effluent Treatment Plant

- ▶ Dissolved oxygen monitors for process control in the activated sludge tanks.
  - ▶ \*pH monitoring at the works outflow.
  - ▶ \*Ammonia monitors.
  - ▶ \*Nitrate monitors.
  - ▶ \*Turbidity monitors.
  - ▶ Process recorder for validation of measurements.
- \* to ensure compliance with discharge consent limits*

## Installation

- ▶ In wastewater applications, sample is generally pumped to the monitor from the outlet waste stream.
  - ▶ A submersible pump is usually required for this duty.
  - ▶ Pressure reduction, isolation and trimming valves may be required to obtain the correct sample flowrate for the monitor (5 to 750ml/min).
- A type 9381 Ultrafilter may also need to be fitted (see 'What ABB Products are Suitable' and the figure below).

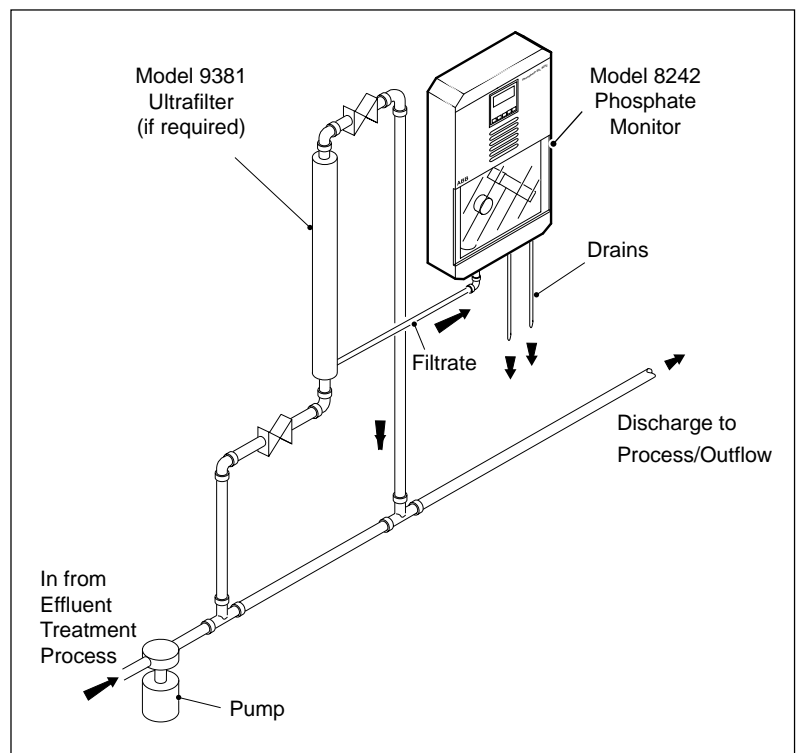

---

ABB has Sales & Customer Support  
expertise in over 100 countries worldwide

[www.abb.com](http://www.abb.com)

The Company's policy is one of continuous product  
improvement and the right is reserved to modify the  
information contained herein without notice.

Printed in UK (12.03)

© ABB 2003



**ABB Limited**

Oldends Lane, Stonehouse  
Gloucestershire  
GL10 3TA  
UK  
Tel: +44 (0)1453 826661  
Fax: +44 (0)1453 827856

**ABB Inc.**

125 E. County Line Road  
Warminster  
PA 18974  
USA  
Tel: +1 215 674 6000  
Fax: +1 215 674 7183