

Use of RAIDK/RXIDK 2H as rotor earth-fault protection

1 General

The rotor circuit of a generator is normally isolated from earth. If the isolation resistance is decreased significantly this can be seen as an earth fault. As the circuit has high impedance to earth one single earth fault will not lead to any direct damages. There is, however, a risk that a second earth fault will occur. In such a case the field circuit will be more or less short-circuited and this can cause severe damages on the generator. Therefore rotor earth faults should be detected and alarmed, so that appropriate actions can be taken to avoid severe generator damages.

2 ABB solution

A voltage injection unit RXTTE 4 is connected to one of the poles of the generator field winding circuit and earth. Either directly to the winding, or via a protective resistor mounted close to the generator. The latter to minimize consequences of a short circuit on the lead connected to the generator field voltage. The measuring relay RXIDK 2H is connected to RXTTE 4 according to the sketch below.

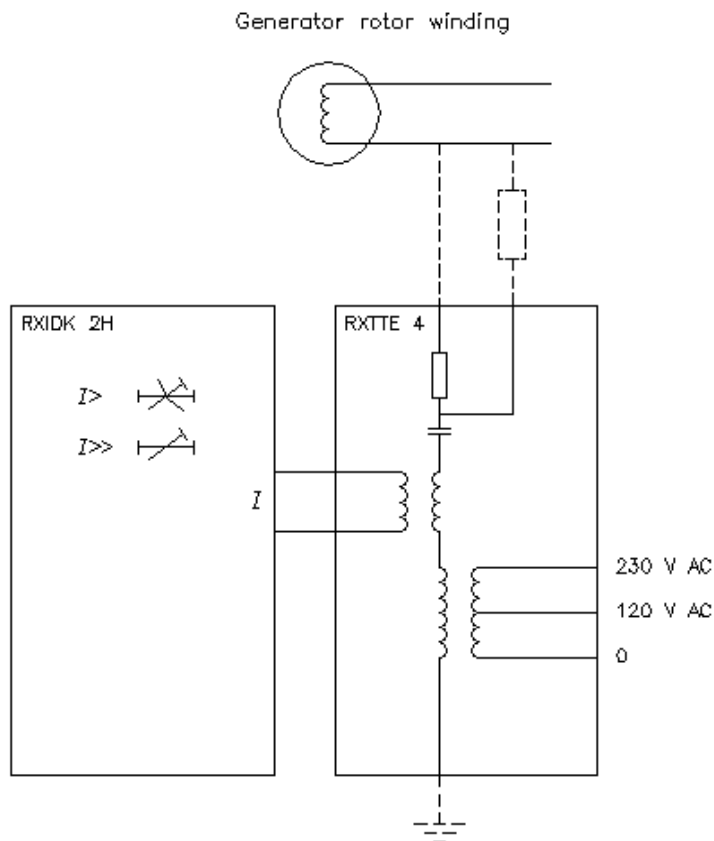

3 Operation

A 50/60 Hz voltage is injected via the injection unit RXTTE 4 to the generator field winding circuit. The injected voltage is 40 V. Series capacitors prevent DC current leakage through the injection unit. The AC current flow during normal service is dependent on the leakage capacitance between the field circuit and earth.

The relay RAIDK/RXIDK 2H measures, via a current transformer in the injection unit, the AC current. This increases when the isolation resistance of the field winding circuit decreases.

The relay has two current stages; the low one with the setting range 15-650 mA and the high one with the setting range 0,02-8 A. For measuring rotor earth-faults, the setting shall be in the range 40-500 mA. Operation will then occur when the isolation resistance to earth is about 10 – 0,4 kohm. The values are somewhat dependent of the value of the leakage capacitance. Typical operate resistance values as a function of the leakage capacitance at different current settings are shown below. The low current stage has both an instantaneous output and a delayed output. The high current stage has a delayed output and it can be used either as a second step in the rotor earth-fault protection or as earth-fault protection for the AC-side. In the latter case it shall be set on approx. 1 A and for disconnection of the excitation voltage.

RXIDK2H, skarp : RXTTE4, 1MRK 002108-BA
50 Hz : R=0

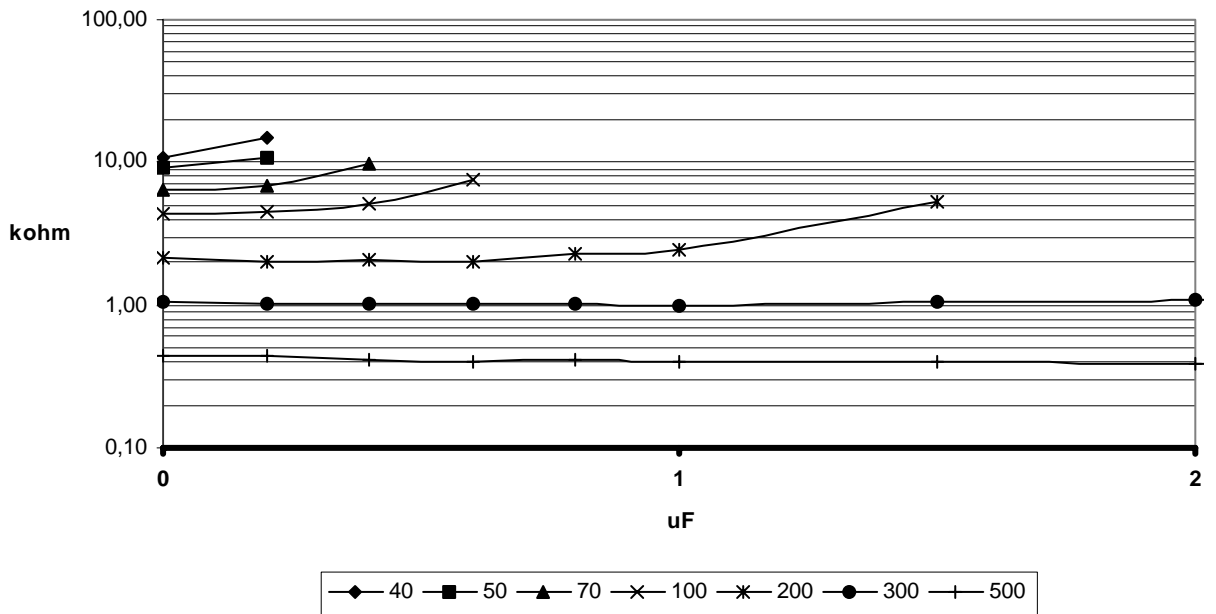

4 Technical data

Permitted field voltage	Maximum 1200 V DC
Supply voltage	120 or 230 V, 50/60 Hz
Operate earth-fault resistance value	Approx. 0,4-10 kohm see diagram above.
Influence of harmonics in the DC field voltage	No influence of 50 V, 150 Hz or 50 V, 300 Hz
Permitted leakage capacitance	0,2 -2 μF, see diagram above.

Permitted shaft earthing resistance	Maximum 200 ohm
Test voltage	5 kV 50 Hz
Protective resistor	220 Ω, 100 W, plate 135x160 mm
Other data for RAIDK/RXIDK 2H	See catalogue 1MRK 509 002-BEN

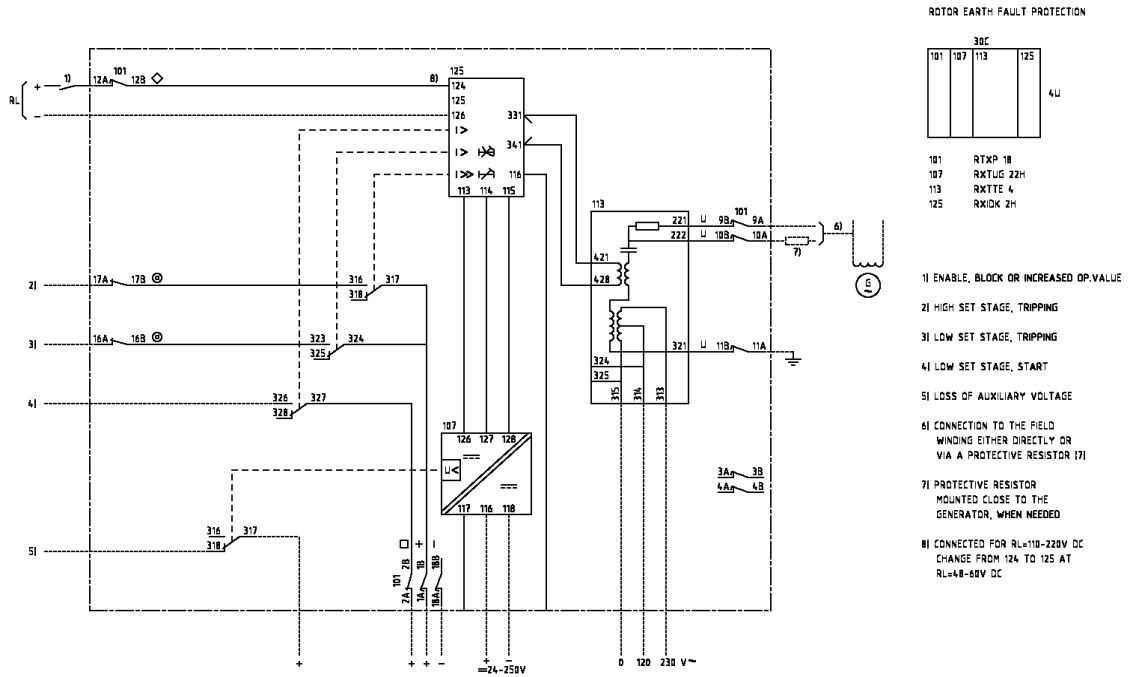

Diagram 1MRK 002 398-BA for rotor earth-fault protection 1MRK 002 397-BA

5 Ordering

RXTTE 4 loose delivery (excl. terminal base) 1MRK 002 108-BA

RAIDK 1 standard protection See catalogue 1MRK 509 002-BEN

Specify:

- 1MRK 000 838-GA for $I_r=0,2$ A, 50-60 Hz (sharp)

Alternative

RAIDK with RTXP 18, RXTUG 22H, RXHL421 and the injection unit RXTTE 4 assembled as one unit 4U 30C, diagram 1MRK 002 398-BA (above)

Specify :

- 1MRK 002 397-BA

Protective resistor mounted on a plate RK 795 102-AD

For more information please contact:

ABB Power Technologies AB

Substation Automation Products

721 59 Västerås, Sweden

Phone: +46 21 342000, Fax: +46 21 324223

www.abb.com/substationautomation