

—
INSTALLATION INSTRUCTION

F-400 Fire rated switch-disconnectors OKA 25...125_F4_

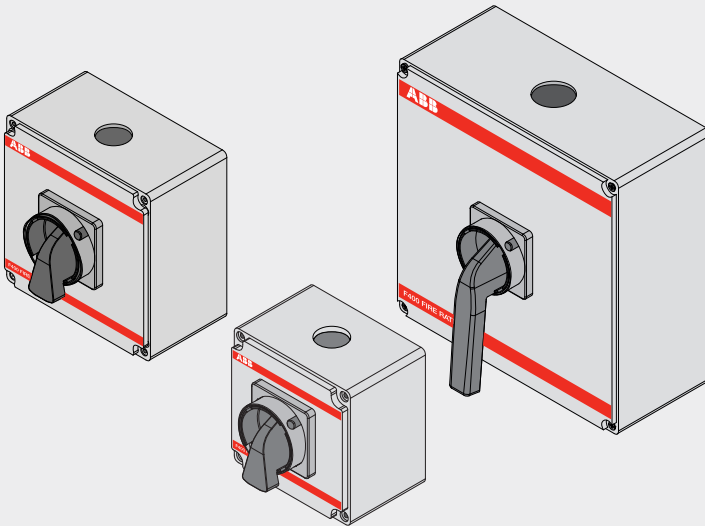
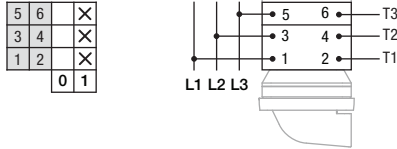

Table of contents

03	Diagrams
04	Wiring
04	Connection
05	Fixing
05	Padlockable handle
06	Dimensions
08	Warning sheet

Diagrams

Switch-disconnector 3P



Switch-disconnector 4P

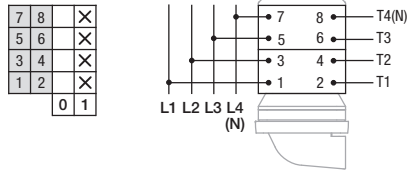

Switch-disconnector 6P

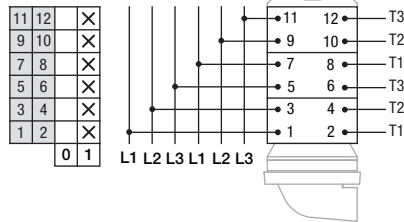

* Early break

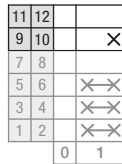

* Auxiliary contacts are 25A. Auxiliary contacts identification number change based on the number of switch cells.

Wiring

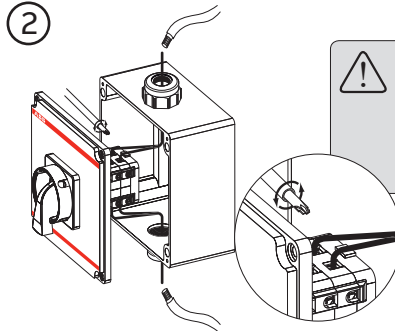
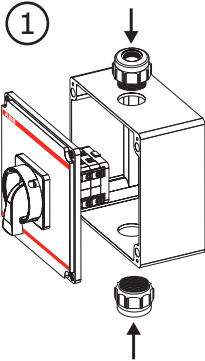

⚠ Retighten all connection screws during installation

	25...40A 2Nm
	63...125A 3,5Nm

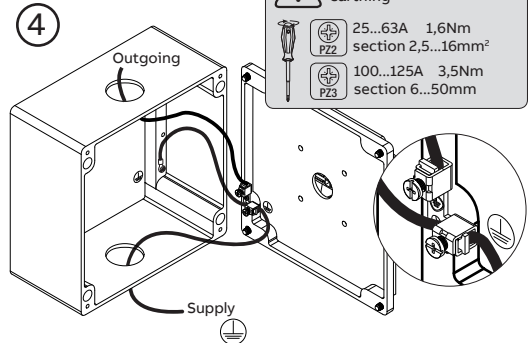
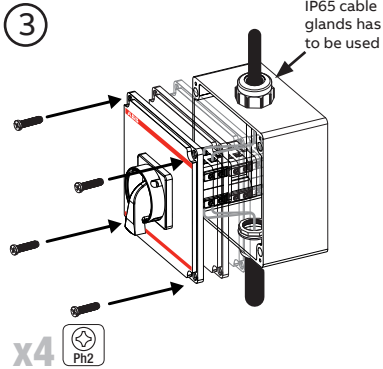



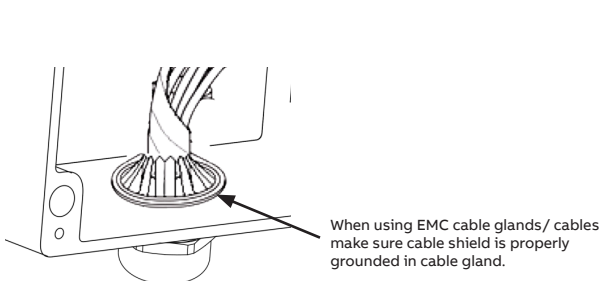

⚠ Enclosure and cover earthing

	25...63A 1,6Nm section 2,5...16mm ²
	100...125A 3,5Nm section 6...50mm



Connection

		OKA 25...40_F4_		OKA 63...125_F4_		
		25A	40A	63A	100A	125A
connect. screws		M5	M5	M8	M8	M8
torque	Nm	2,0	2,0	3,5	3,5	3,5
terminal						
flexible wire section	mm ²	2,5...16	2,5...16	6...50	6...50	6...50

Fixing

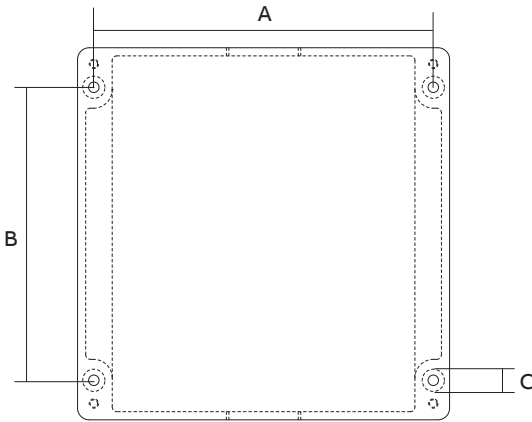

Switch Type	A	B	C (Ø x n°)
OKA 25_F4_	116	96	5,5 x 4
OKA 40_F4_	146	126	5,5 x 4
OKA 63...125_F4_	230	206	6,5 x 4

Padlockable handle

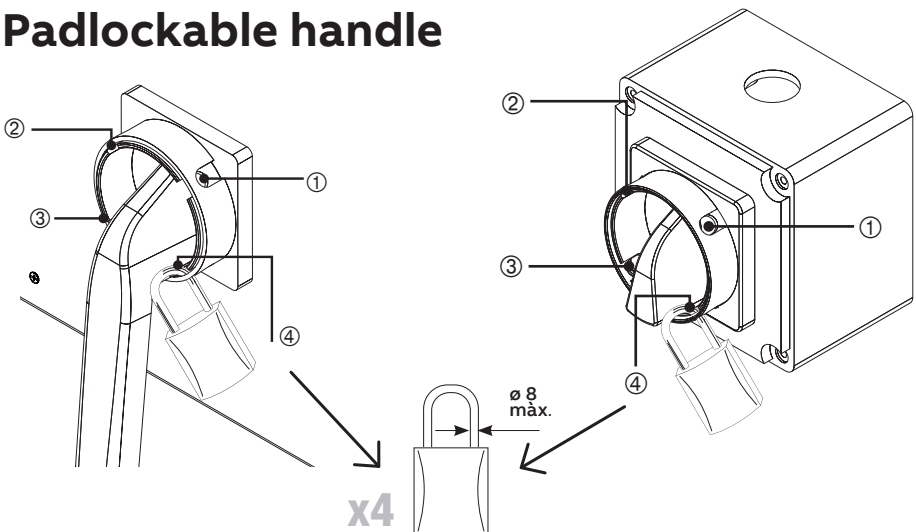

Dimensions

Box size OKA 25_F4_
F-400 25A

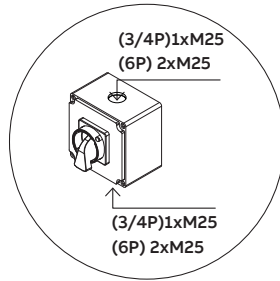
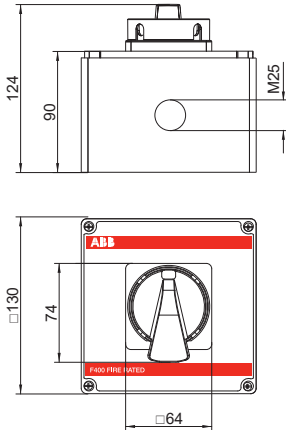

Box size OKA 40_F4_
F-400 40A

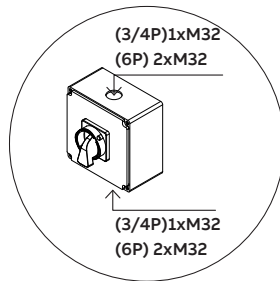
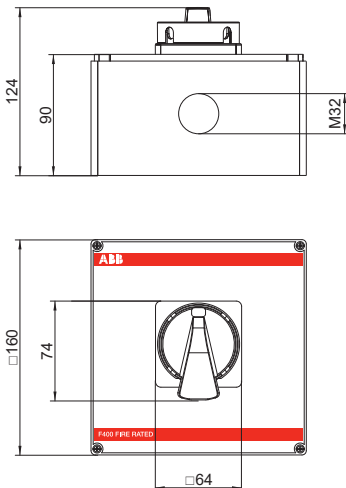

Box size OKA 63...125_F4_
F-400 63A 6P 100 - 125A

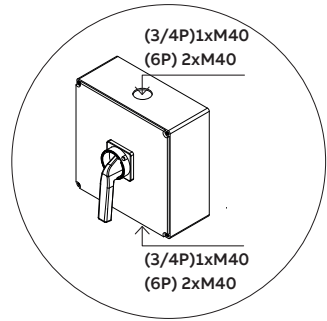
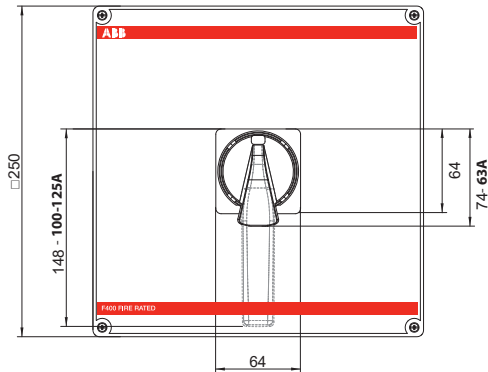
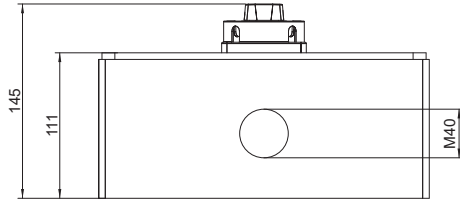

		3/4 Poles	6 Poles
25A	Top	1xM25	2xM25
	Botton	1xM25	2xM25
40A	Top	1xM32	2xM32
	Botton	1xM32	2xM32
63A	Top	1xM40	2xM40
	Botton	1xM40	2xM40
100-125A	Top	1xM40	2xM40
	Botton	1xM40	2xM40

* Switches F-400 6P + Aux. C. not contemplated.



Contact us

ABB Oy

P.O. Box 622
FI-65101 Vaasa
Finland

abb.com/lowvoltage

© Copyright 2020 ABB. All rights reserved.
Specifications subject to change without notice.



BG	Внимание! Опасно напряжение! Да се монтира само от лице с електротехническа квалификация.
FR	Avertissement! Tension électrique dangereuse! Installation uniquement par des personnes qualifiées en électrotechnique.
MT	Twissija! Vultaġġ perikoluż! Għandu jiġi installat biss minn persuna b'kompetenza elettroteknika.
HR	Upozorenje! Opasan napon! Postavljati smije samo elektrotehnički stručnjak.
DE	Warnung! Gefährliche Spannung! Installation nur durch elektrotechnische Fachkraft.
PL	Ostrzeżenie! Niebezpieczne napięcie! Instalacji może dokonać wyłącznie osoba z fachową wiedzą w dziedzinie elektrotechniki.
CZ	Varování! Nebezpečné napětí! Montáž smí provádět výhradně elektrotechnik!
EL	Προειδοποίηση! Υψηλή τάση! Η εγκατάσταση πρέπει να γίνεται μόνο από εξειδικευμένους ηλεκτροτεχνικούς.
PT	Aviso! Tensão perigosa! A instalação só deve ser realizada por um electricista especializado.
DA	Advarsel! Farlig elektrisk spænding! Installation må kun foretages af personer med elektroteknisk ekspertise.
HU	Figyelmeztetés! Veszélyes feszültség! Csak elektrotechnikai tapasztalattal rendelkező szakember helyezheti üzembe.
RO	Avertizare! Tensiune periculoasă! Instalarea trebuie efectuată numai de către o persoană cu experiență în electrotehnică.
NL	Waarschuwing! Gevaarlijke spanning! Mag alleen geïnstalleerd worden door een deskundige elektrotechnicus.
IE	Rabhadh! Voltas guaiseach! Ba chóir do dhuine ag a bhfuil saimeolas leictreicniúil, agus an té sin amháin, é seo a shuiteáil.
SK	Varovanie! Nebezpečné napätie! Montáž môže vykonávať iba skúsený elektrotechnik.
EN	Warning! Hazardous voltage! Installation by person with electrotechnical expertise only.
IT	Avvertenza! Tensione pericolosa! Fare installare solo da un elettricista qualificato.
SL	Opozorilo! Nevarna napetost! Vgradnjo lahko opravi le oseba z elektrotehničnim strokovnim znanjem.
ET	Hoiatus! Ohtlik pinge. Paigaldada võib ainult elektrotehnika-alane ekspert.
LV	Uzmanību! Bīstami - elektrība! Montāžas darbus drīkst veikt tikai personas, kurām ir atbilstošas elektrotehnikās zināšanas.
ES	¡Advertencia! ¡Tensión peligrosa! La instalación deberá ser realizada únicamente por electricistas especializados.
FI	Varoitus! Vaarallinen jännite! Asennuksen voi tehdä vain sähköalan ammattihenkilö.
LT	Dėmesio! Pavojinga įtampa! Dirbti leidžiama tik elektrotechniko patirties turintiems asmenims.
SE	Warning! Farlig spänning! Installation får endast utföras av en elektriker.
CN	警告！电压危险！只能由专业电工进行安装。
RU	Осторожно! Опасное напряжение! Монтаж должен выполняться только специалистом-электриком.

6302502-6-4359

34 OKA25-125_F4 rev. B /
1SCC 340174M0201# 29.11.2019