

August, 1991  
Supersedes DB 41-570, pages 1-20,  
dated December, 1987  
Mailed to: E, D, C/41-500A

For Ac and Dc Application  
Requiring A Definite Time Delay  
**Device Number: 2**

## Types TK, TD-4, TD-5, TD-50 and TD-52 Timing Relays

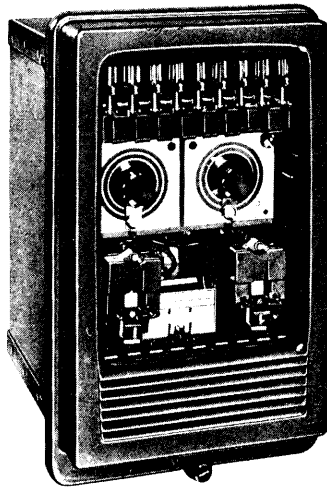

Type TD-52  
FT-22 Case

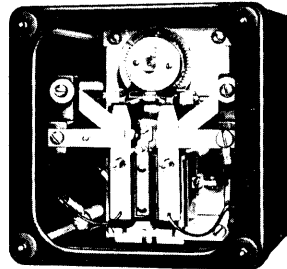

Type TK  
Square Metal Case

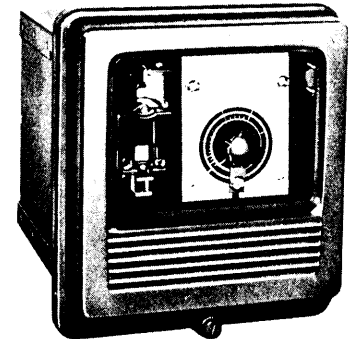

Type TD-5  
FT-11 Case

### Applications

#### Industrial Control

Intermittent duty in process timing (electroplating, heating, annealing, etc.)

#### General Auxiliary Service

Coordinating sequential switching functions.

#### Protective Relaying

Required time delay to obtain selective relay coordination.

#### Motor Control

Timed steps to cut out starting resistance.

#### Power Line Carrier

Automatic check-back schemes in checking transmission of carrier between terminals.

#### Distance Relaying

Time delay backup, zone tripping.

### Selector Guide

Relay Type	Page	Device Number	Range of Operating Time Delay	Ratings	
				60 Hertz	Dc
TK	2	2	2-30 sec. 18 sec. - 5 min. 3 min. - 50 min.	115 volts 208 volts 230 volts 460 volts 575 volts	125 and 250 volts dc application require a dc/ac inverter for timer motor operation
TD-4	6	2	zone 2: 0.1 - 1.0 seconds zone 3: 0.5 - 3.0 seconds 0.3 - 1.5 seconds	...	48/125/250 volts
TD-5, 52	12	2	.05 - 0.4 .05 - 1.0 0.2 - 4.0 1.5 - 30.0	...	24/32 volts 48/125 volts 250 volts
TD-50	16	2	.05 - 0.4 .05 - 1.0 0.2 - 4.0	...	125 volts 48/125 volts

**Type TK**

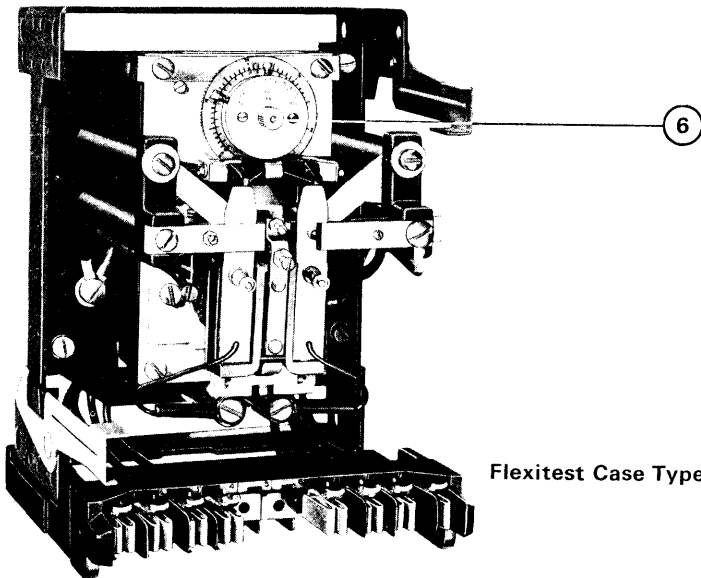

Flexitest Case Type

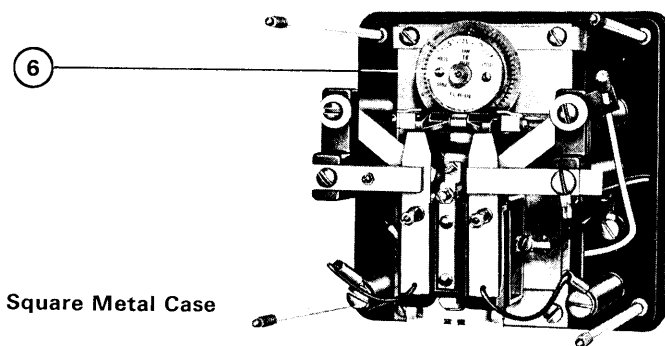

Square Metal Case

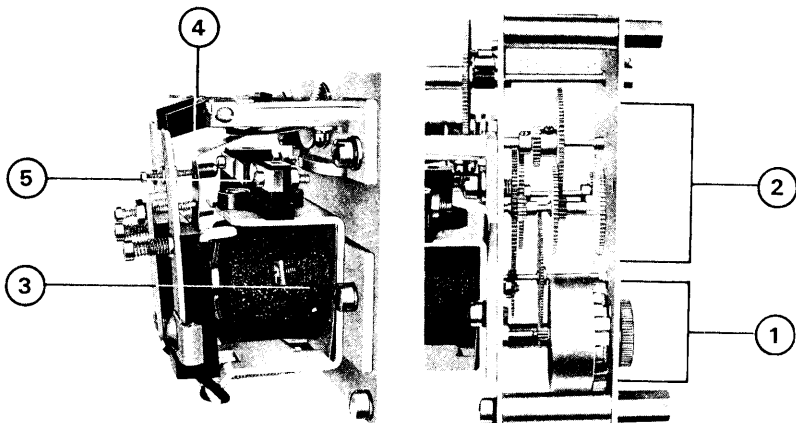

**Application**

The TK relay is an ac timing relay for applications requiring a definite time delay between the closing of other ac or dc circuits.

Accurate time settings can be obtained from two seconds to fifty minutes. The reset time for any setting is less than one second.

The TK relay is widely used in industrial applications, or where a time delay is required in motor, generator, or rectifier control circuits.

One style is suitable for use with a dc to ac inverter where a reliable ac control voltage is not available. See Bulletin Descriptive 41-075D for further information on the inverter.

**Construction and Operation**

- ① **Synchronous Motor**  
Drives gear train. Runs at a synchronous speed of 600, 500, or 250 rpm for 60, 50 or 25 hertz, respectively.
- ② **Gear Train**  
Three different speed settings of 30 seconds, 5 minutes, and 50 minutes are obtained by changing the location of a sliding gear assembly.
- ③ **Contactors Coil**  
On relays rated 230 volts or higher (60 hertz), a tap is brought out to act as an autotransformer to supply 115 volts to the timing motor.
- ④ **Contactors**
- ⑤ **Seal-In Contact** (Optional)  
Keeps the relay energized until the circuit is opened by a switch external to the relay.
- ⑥ **Time Scale**  
Calibrated for three timing ranges.

## Burden Data

All ac ratings are 60 hertz

Coil Rating	Watts	Burden	Reactive Volt-Amperes	Power Factor Angle-Lag
Motor (115 volts ac)	1.8	2.5 volt-amperes	1.73	44°
Contact (115 volts ac)	11.5	18.5 volt-amperes	14.5	51°

## Contact Data

Contact	Voltage of Control Circuit	Amperes Contact Will: (Non-Inductive Load)		
		Open	Close	Carry Continuously
#1, #2Ⓢ	120 ac	20	20	12
	230 ac	15	20	12
	125 dc	2	20	12
Seal-in, cc	115 ac	2	2	2
	125 ac	...	2	2

Ⓢ Values given are for circuit closing contacts. #1 circuit opening contact will carry 8 amps at same voltages continuously. #1 closing and opening current values are the same as the circuit closing contacts #1 and #2.

## Characteristics

In the 50 and 60 hertz relays the time settings available for the three gear positions are:

Minimum	Maximum
2 sec.	30 sec.
0.3 min. (18 sec.)	5 min.
3 min.	50 min.

The smallest sub-division is one second on the 30 second scale, 0.1 minute (6 seconds) on the 5 minute scale, and 1 minute on the 50 minute scale.

With the 25 hertz relays, the maximum time setting available for the three gear positions are 1, 10, and 100 minutes. The smallest sub-division is 2 seconds on the 1 minute scale, 0.2 minute on the 10 minute scale, and 2 minutes on the 100 minute scale.

Reset time for maximum travel is less than one second.

## Motor

The motor will operate at 10% above or 15% under rated voltage.

## Main Contacts

The two sets of main contacts can be adjusted to operate either simultaneously or sequentially. The left hand set is single-pole double-throw (make and break), and the right hand set is single-pole single-throw (make). The right hand contact arm also operates the independent break motor circuit contact. The make contacts will carry 12 amperes continuously and 20 amperes for one minute. The break contact has somewhat less pressure, and will carry about 2/3 this rating. The contacts will open 2 amperes at 125 volts dc; or a non-inductive current of 20 amperes at 115 volts ac, or 15 amperes at 230 volts ac.

**TK Internal Wiring (Front-View)**  
**AC Operated with Sealing Contact, FT-21 Case**

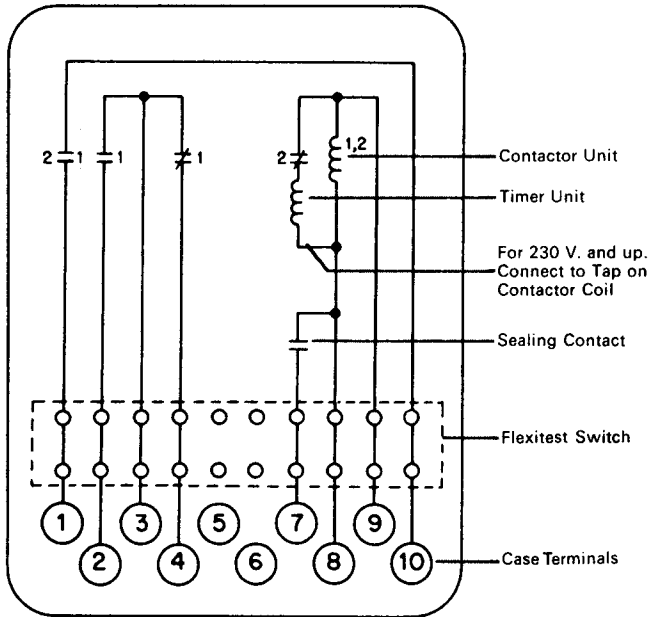

Note:  
1. Operates First in Sequence  
2. Operates Next in Sequence

Fig. 1 57-D-7909

**Dc Operated With Inverter, Without Sealing Contact, FT-21 Case**

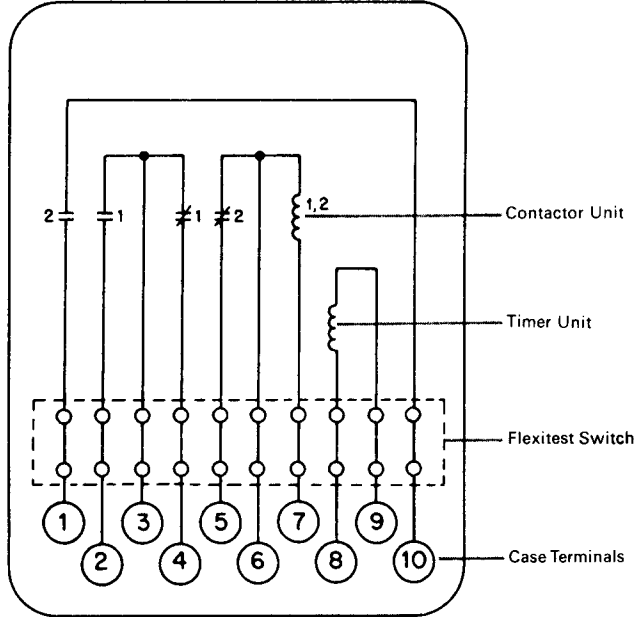

Note:  
1. Operates First in Sequence  
2. Operates Second in Sequence

Fig. 2 57-D-7911

**Dc Operated With Inverter, With Sealing Contact, With Momentary Start Contact, FT-21 Case**

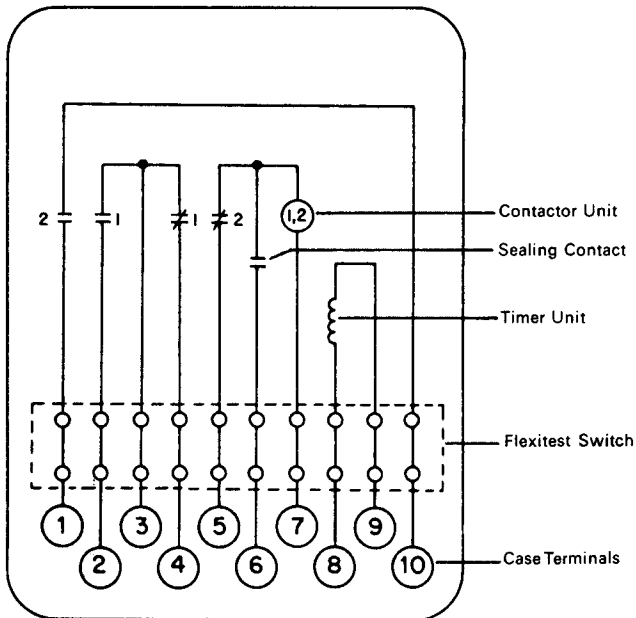

Note:  
1. Operates First in Sequence  
2. Operates Second in Sequence

Fig. 3 183A208

**Ac Operated With Sealing Contact, With Shaft Contact To Prevent Energization Before Relay Has Reset, FT-21 Case**

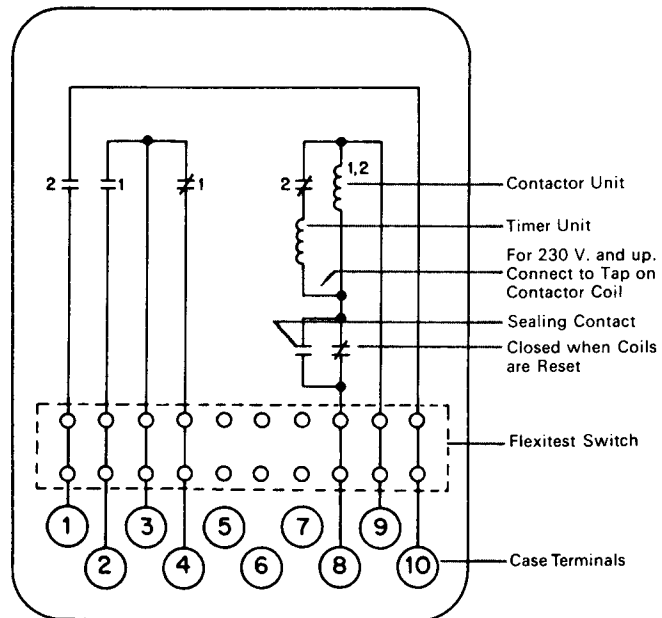

Note:  
1. Operates First in Sequence  
2. Operates Next in Sequence

Fig. 4 57-D-7910

### Metal Cases (Rear View)

Dc Operated With Inverter, Without Sealing Contacts,  
5½" Metal Case

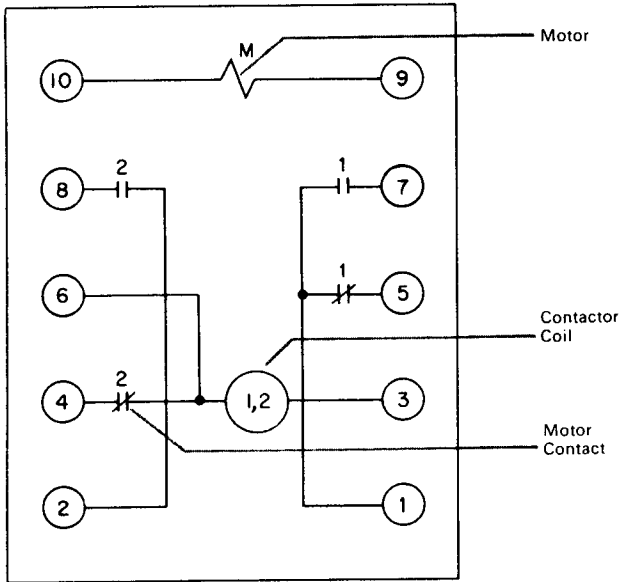

Note:

1. Operates First in Sequence
2. Operates Next in Sequence

Fig. 5 78-D-245

Ac Operated Without Sealing Contacts,  
5½" Metal Case

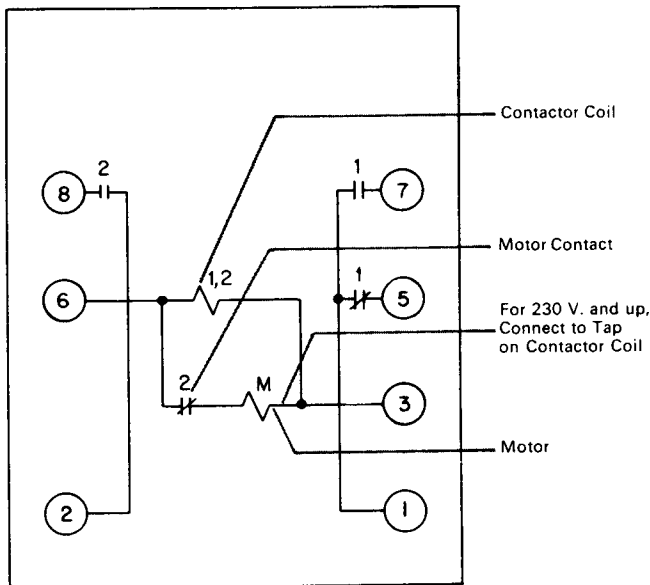

Note:

1. Operates First in Sequence
2. Operates Next in Sequence

Fig. 7 56-D-806

Ac Operated With Sealing Contacts,  
5½" Metal Case

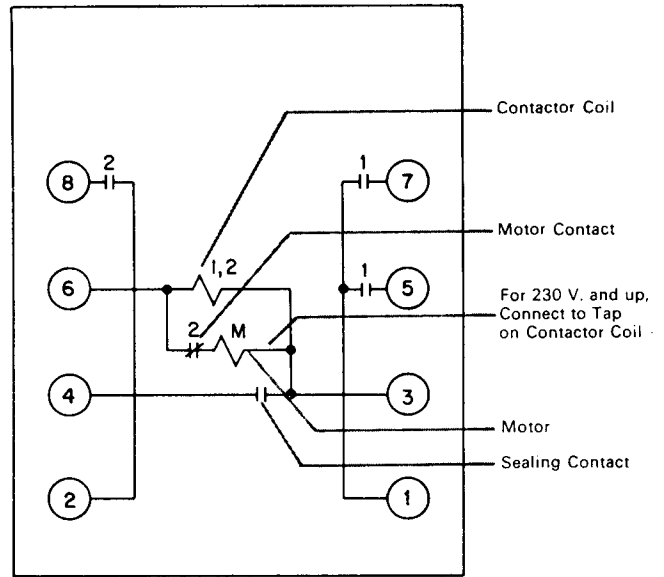

Note:

1. Operates First in Sequence
2. Operates Next in Sequence

Fig. 6 56-D-807

### External Wiring TK Relay In FT-21 Case<sup>①</sup> Device Numbers

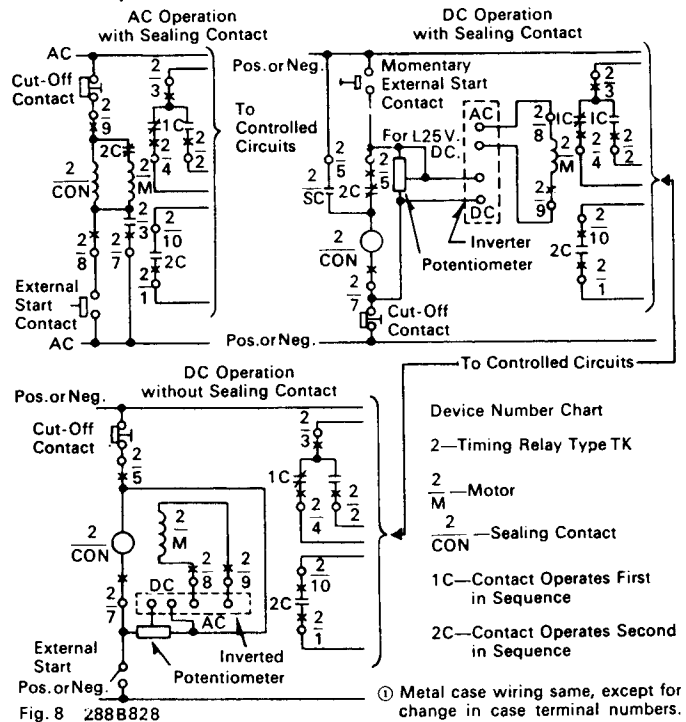

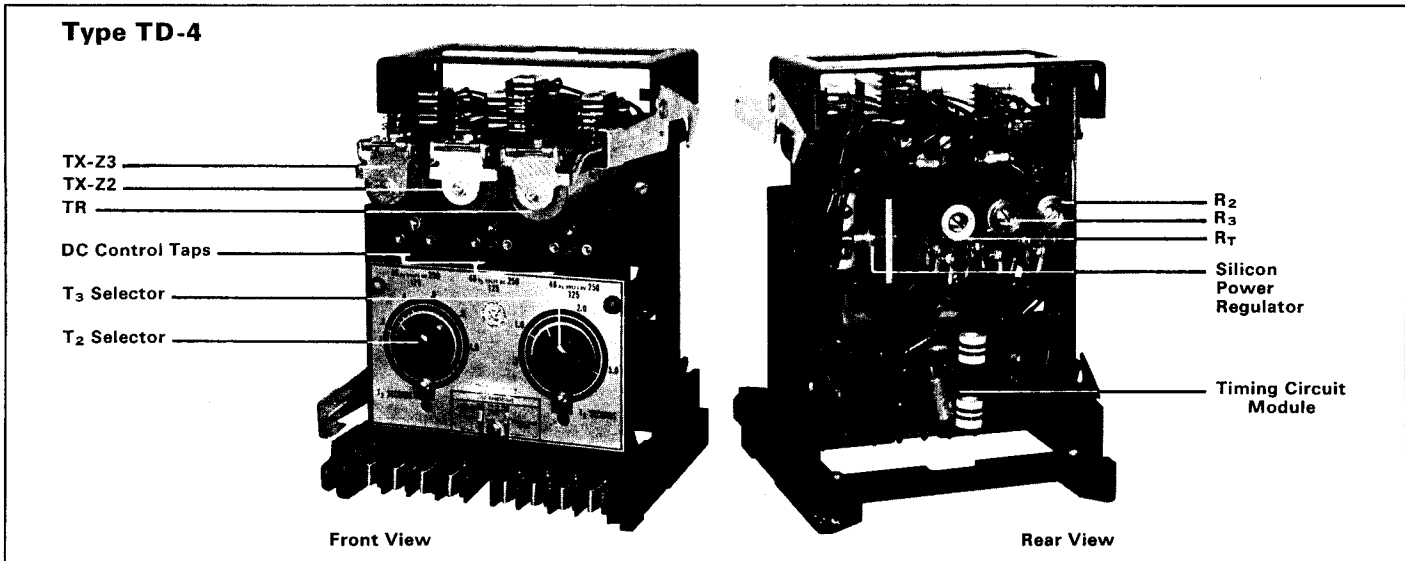

**Application**

The TD-4 relay may be used for any timing application requiring a two-stage timing interval. The first stage being adjustable from 0.1 to 1.0 seconds, and the second stage for 0.5 to 3.0 seconds. The relay operates from a dc source of 48, 125, or 250 volts dc.

This relay is particularly suitable for use as a timing unit for the second and third zone KD-4 and KD-41 relays in a compensator distance relaying scheme. By proper connections in the relaying scheme, the TD-4 will provide a single time delay for zone 2 faults, or a longer time delay for zone 3 faults.

**Construction**

The TD-4 consists of an auxiliary circuit (consisting of two telephone type relays (TX-Z2, TX-Z3) and two tapped resistors (R<sub>2</sub>, R<sub>3</sub>) to initiate the time delay; a reference voltage circuit consisting of a silicon power regulator (DZ) and a tapped resistor (RT); a time delay circuit with two rheostats (T<sub>2</sub>, T<sub>3</sub>); a telephone relay (TR); and a timing circuit module (M).

**Operation**

**Zone 2, Non-Carrier**

For a zone 2 fault, both zone 2 and zone 3 KD-4 contacts close, energizing both TX-Z2 and TX-Z3. This completes the dc reference voltage. When the time delay is completed, telephone relay TR is energized and completes the trip circuit path through the normally open TX-Z2 contact.

**Zone 2, Carrier**

This case is similar to Zone 2, Non-Carrier except that the zone 2 KD contact only is closed. Therefore, only TX-Z2 is energized since zone 3 reach is reversed. The operation of the timing circuit and trip circuit is identical to that described for Zone 2, Non-Carrier.

**Zone 3, Carrier Or Non-Carrier**

For a zone 3 fault the zone 3 KD-41 contact only is closed. This energizes TX-Z3 and completes the timing circuit. At the end of the time delay, TR is energized and completes the trip path through the normally closed TX-Z2 contact.

**Zone 2 Fault Which Appears As A Zone 3 Fault, Due to Infeed**

A zone 2 fault may appear to a distance relay as a zone 3 fault. This condition occurs when current infeed changes the apparent impedance as seen by the distance relay.

When this fault occurs, the zone 3 distance relay energizes TX-Z3 and starts the timing function at the zone 3 rate, as described in Zone 3, Non-Carrier or Carrier. As soon as the infeed is removed, the zone 2 distance relay operates to energize TX-Z2. The timing function now continues at the zone 2 rate. The total time delay depends on the T<sub>2</sub> setting, the T<sub>3</sub> setting, and the time at which the breaker clears the infeed. In any event, the trip time following zone 2 KD-4 operation will be less than the T<sub>2</sub> setting.

**Characteristics**

**Time Delay Range**

Zone 2: 0.1 second – 1.0 second  
Zone 3: 0.5 second – 3.0 second or 0.3 second – 1.5 second.

**Reset Time**

TR Dropout Time: 0.1 second or less.  
TX-Z2, TX-Z3 Dropout Time: 0.06 second or less.

Discharge To timing Capacitor: Discharges to less than 1% of full voltage in 0.015 second.

**For relays with slow dropout, reset time is:**

TX-Z2 Dropout Time: .045 – .075 second  
TX-Z3 Dropout Time: .090 – 0.15 second

**Voltage Rating Over the Temperature Range**

48, 125, or 250 volts dc. The relay can stand 110% voltage continuously from -20°C to +70°C.

**Battery Drain**

	48 Volts Dc	125 Volts Dc	250 Volts Dc
Non Operating Condition	0	0	0
Operating Condition:			
Timing Circuit and DZ <sub>1</sub> . . . . .	50-90 ma	30-80 ma	25-70 ma
TX-Z2 . . . . .	117 ma	106 ma	103 ma
TX-Z3 . . . . .	117 ma	106 ma	103 ma

**Accuracy**

The accuracy of the time delay depends upon the repetition rate of consecutive timings, the supply voltage, and the ambient temperature. Self-heating has a negligible effect on the timing accuracy.

## Time Delay Versus Ambient Temperature

Relay Type TD-4 Time Delay Versus Ambient Temperature

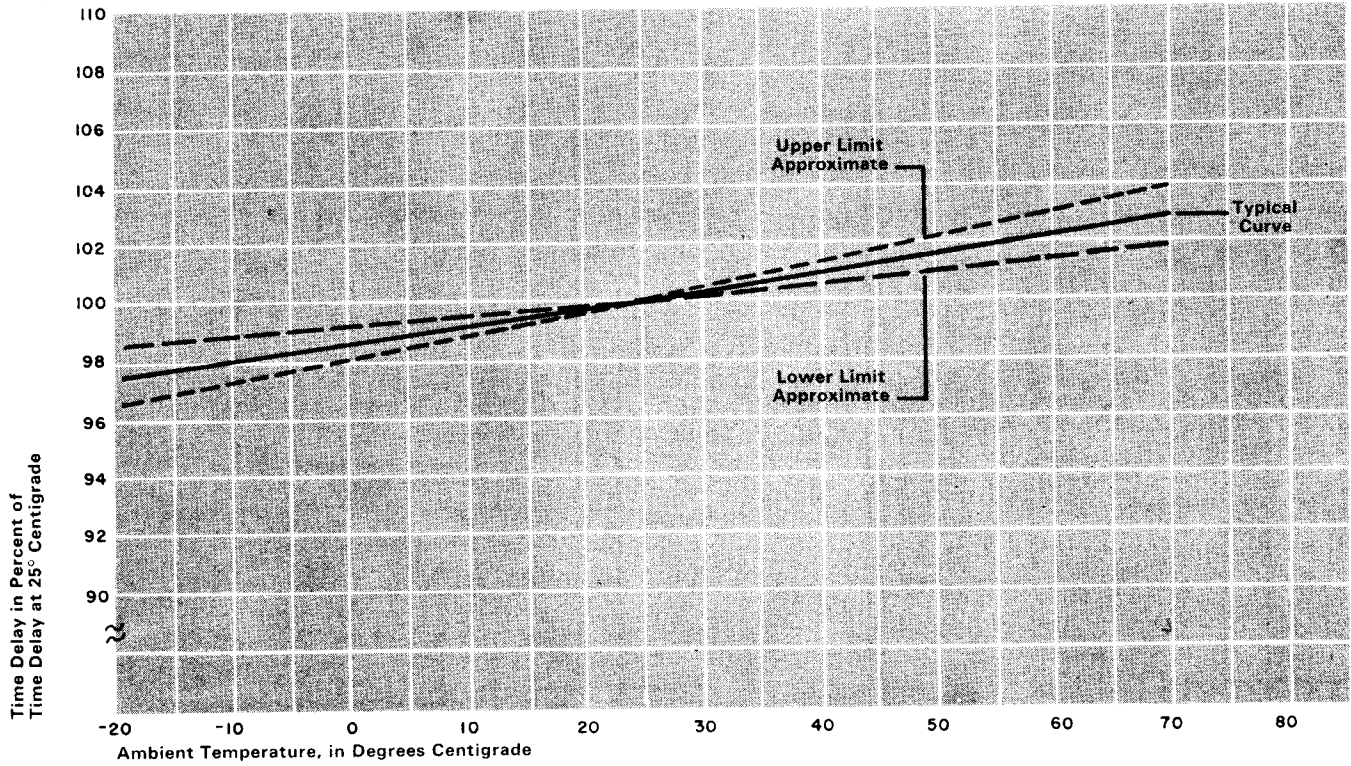

Fig. 9 185A171

## Type TD-4 Voltage Time Curve

Zone 2 Range 0.1-1.0 Sec.  
Zone 3 Range 0.5-3.0 Sec.

Reference Voltage

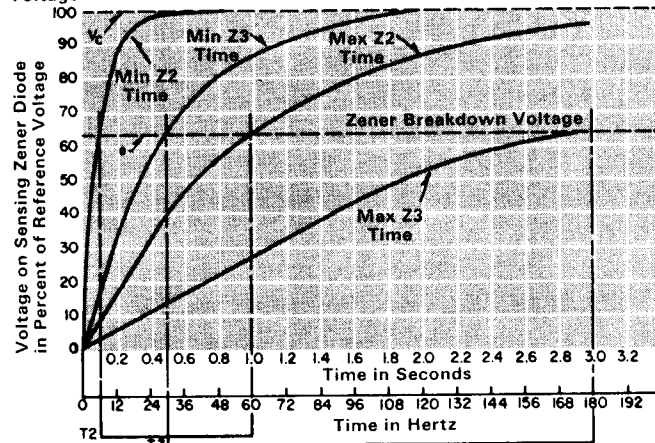

Fig. 10 471118

## Timer Control Circuit

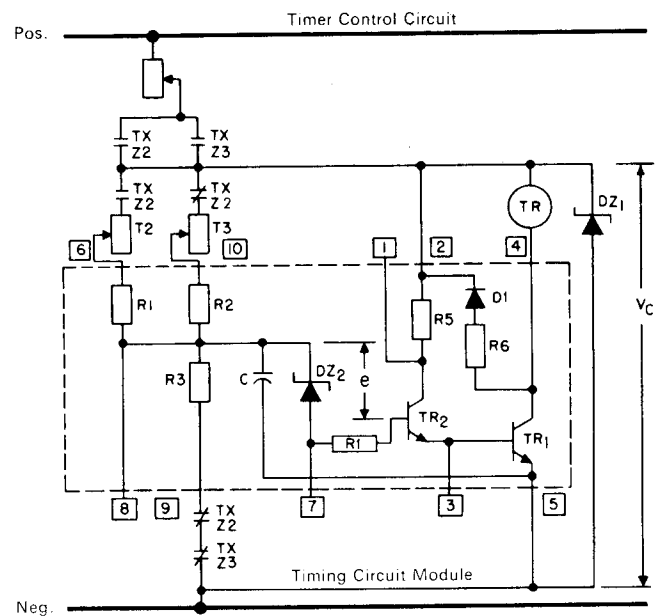
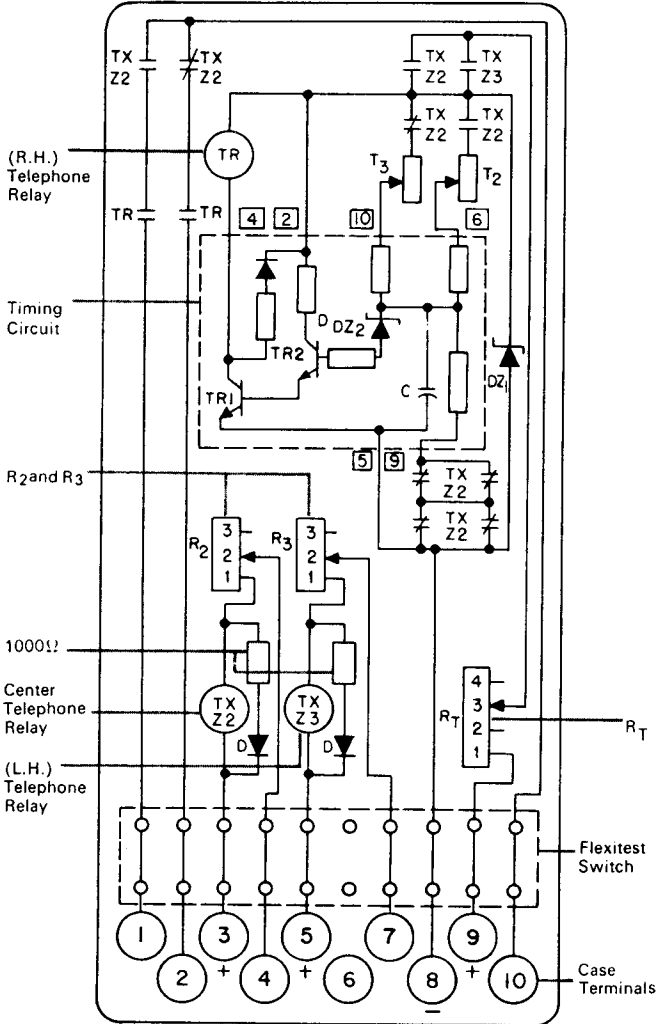

Fig. 11 185A515



**TD-4 Internal Wiring (Front-View)**  
With Slow Dropout, FT-21 Case



R2 and R3			RT		
D.C. Control CKT.			D.C. Control CKT.		
Trip Volt	Lead Position	Resis. Value	Trip Volt	Lead Position	Resis. Value
48	1	0	48	1	0
125	2	750	125	2	350
250	3	2000	125	3	2500
			250	4	6500

Fig. 12 185A210

**Independent Tripping Circuits, FT-21 Case**

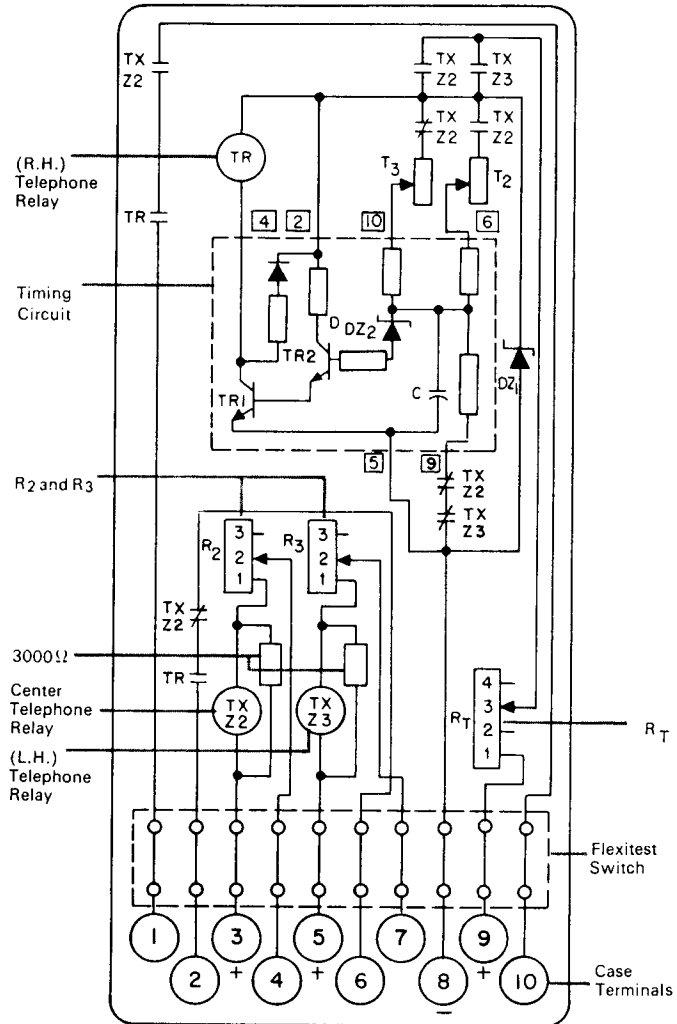

R2 and R3			RT		
D.C. Control CKT.			D.C. Control CKT.		
Trip Volt	Lead Position	Resis. Value	Trip Volt	Lead Position	Resis. Value
48	1	0	48	1	0
125	2	750	125	2	350
250	3	2000	125	3	2500
			250	4	6500

Fig. 13 185A232



**With Slow Dropout And Independent Tripping Circuits, FT-21 Case**

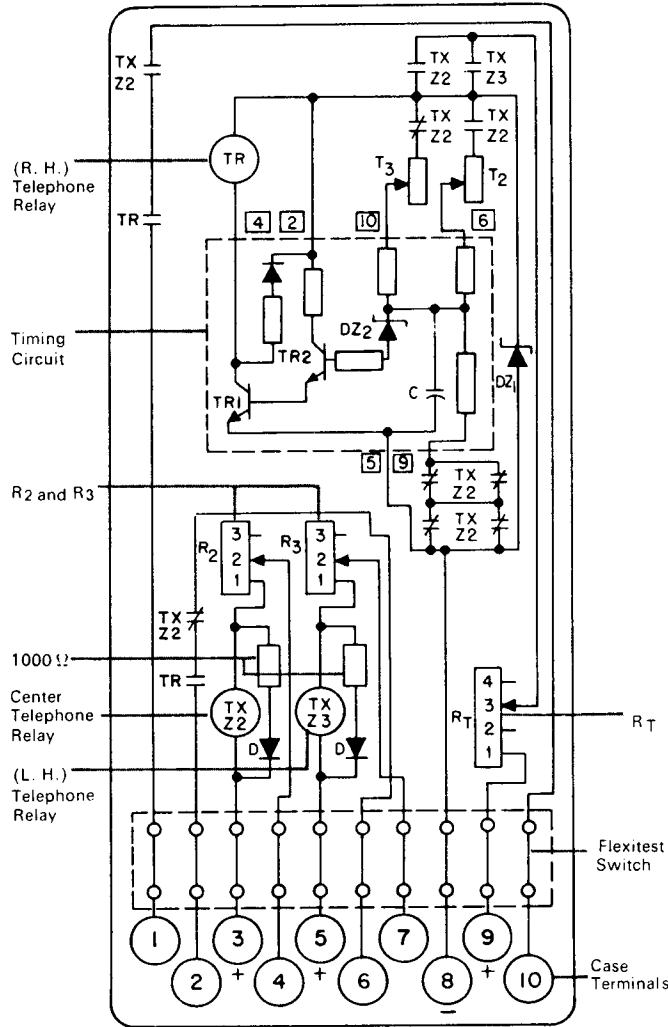

R <sub>2</sub> and R <sub>3</sub>			R <sub>T</sub>		
D.C. Control CKT			D.C. Control CKT.		
Trip Volt	Lead Position	Resis. Value	Trip Volt	Lead Position	Resis. Value
48	1	0	48	1	0
125	2	750	125	2	350
250	3	2000	250	3	2500
			250	4	6500

Fig. 14 837A071

**FT-21 Case**

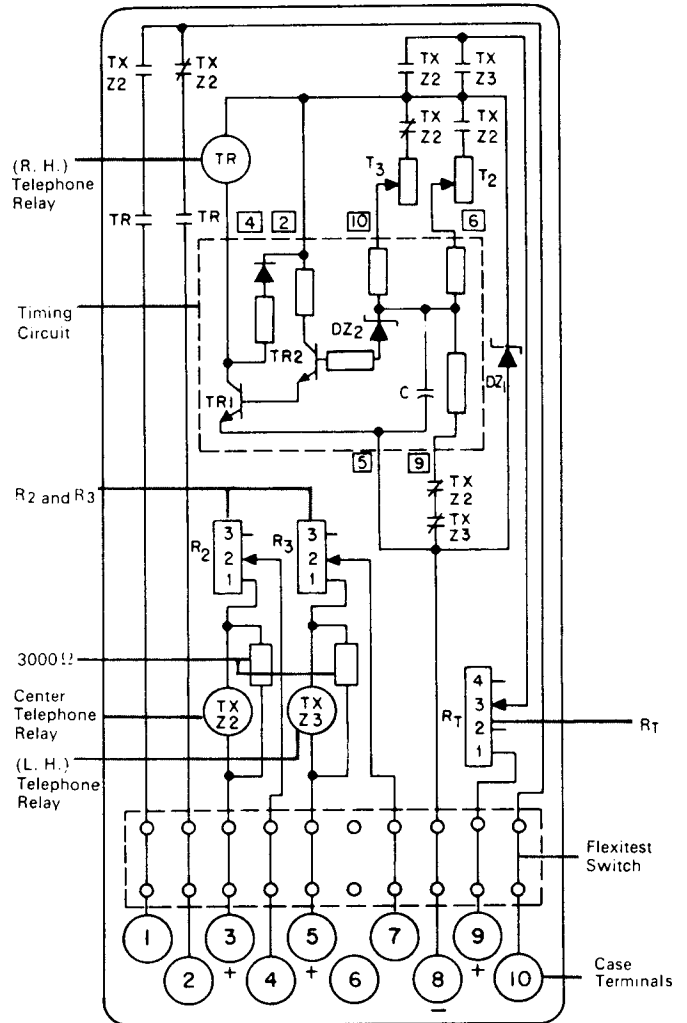

R <sub>2</sub> and R <sub>3</sub>			R <sub>T</sub>		
D.C. Control CKT			D.C. Control CKT.		
Trip Volt	Lead Position	Resis. Value	Trip Volt	Lead Position	Resis. Value
48	1	0	48	1	0
125	2	750	125	2	350
250	3	2000	250	3	2500
			250	4	6500

Fig. 15 184A615

External Wiring KD-10 Relaying Using Two KD-10, One KD-11, And One TD-4 Relay

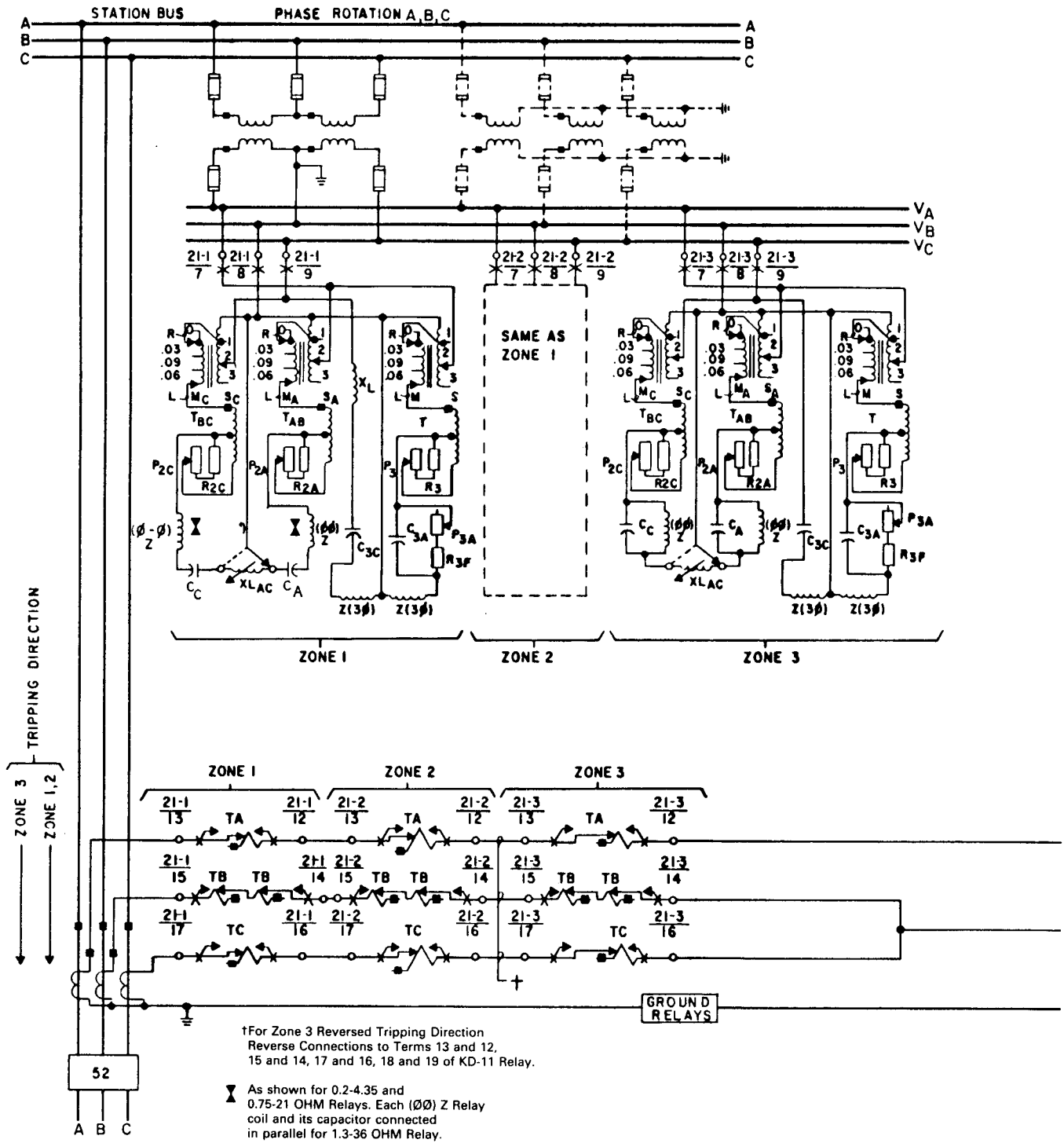

†For Zone 3 Reversed Tripping Direction Reverse Connections to Terms 13 and 12, 15 and 14, 17 and 16, 18 and 19 of KD-11 Relay.

⚡ As shown for 0.2-4.35 and 0.75-21 OHM Relays. Each (∅∅) Z Relay coil and its capacitor connected in parallel for 1.3-36 OHM Relay.

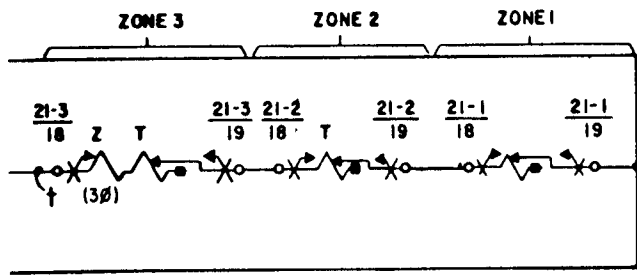
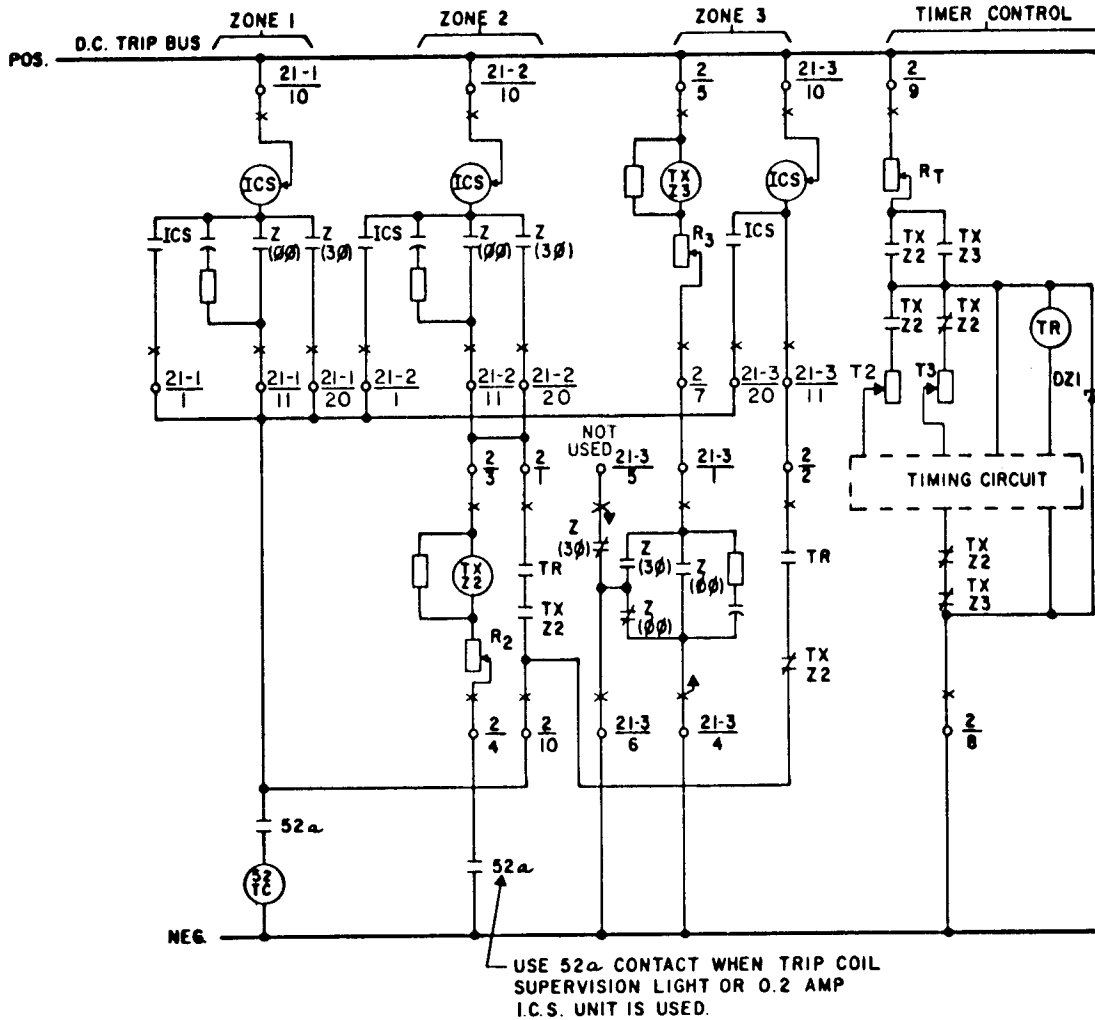

Resistance Values in OHMS

	48 V.D.C.	125 V.D.C.	250 V.D.C.
R <sub>T</sub>	350	2500	6500
R <sub>2</sub>	0	750	2000
R <sub>3</sub>	0	750	2000

Device Number Chart

Device No.	Zone	Device Relay	Device
21-1	1	KD-10	
21-2	2	KD-10	
21-3	3	KD-11	
2		TD-4 Timing	
52			Power CKT. BKR.
52a			BKR. AUX. Contact
52TC			BKR. Trip Coil

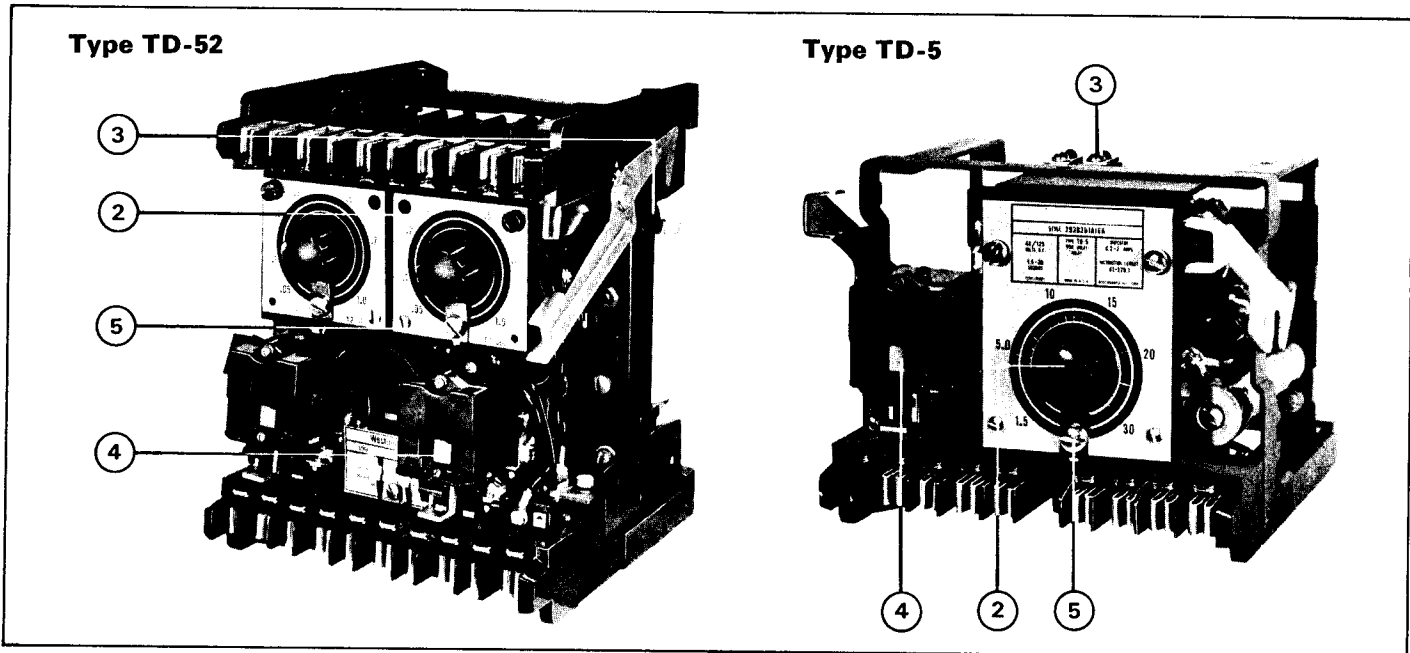

The TD-5 is a general purpose timing relay which may be used for applications requiring a time delay within the overall range of 0.5 to 30 seconds.

It operates from a dc source of 24, 32, 48, 125 or 250 volts. It will stand 110% of rated input voltage continuously over an ambient temperature range of  $-40^{\circ}\text{C}$  to  $+70^{\circ}\text{C}$ .

The TD-52 consists of two TD-5 units mounted in an FT-22 case. This allows utilization of two completely independent timing circuits for such applications as primary and back-up relaying systems.

The telephone type output relay contacts are suitable for circuit breaker trip duty. Two sets of transfer contacts adapt the relay to various trip circuit arrangements.

**Construction**

- ① **Reference Voltage Circuit**  
Provides a fixed supply voltage to the time delay circuit, and protects the solid state components from high voltages.
- ② **Rheostat And Scale Plate**  
Non-linear calibrating scale plate permits more accurate settings at the lower end of the scale.
- ③ **Telephone Relay (TR)**  
Energized by the SCR at the conclusion of the time delay. The coil is energized by at least three times pickup wattage to insure positive contact operation.

- ④ **Indicating Contactor Switch**
- ⑤ **Rheostat Locking Screw**
- ⑥ **Additional Telephone Relay**

TD-5 units are also available with an additional telephone type relay (TX) which is energized by application of dc voltage to the relay. A contact of the TX unit seals in around the contact of the initiating relay to maintain voltage to the timing circuit, should the contact of the initiating relay bounce. A diode and resistor connected across the TX unit coil protects the solid state circuitry from inductive voltage kicks.

**Characteristics**

**Relay Burden Data**

Relay Rating	Standby	Operating
24 v dc	0	500 ma
32 v dc	0	420 ma
48 v dc	0	270 ma
125 v dc	0	180 ma
250 v dc	0	80 ma

**TX Telephone Relay Burden Data**

Trip Circuit	Watts
125 v dc	7.8
48 v dc	3.1

**Accuracy**

The accuracy of the time delay is affected by:

**Repetition Rate of Timings**

The reset time of the relay can affect the next timing cycle if started before the capacitor discharge is complete. Timing accuracy for normal repetitive rates are as follows:

Relay Rating In Seconds	Minimum Delay (Seconds) Between Timings	Accuracy (In Percent of Setting) ①
.05 - 1.0	3	$\pm 2\%$
.2 - 4.0	5	$\pm 2\%$
1.5 - 30	5	$\pm 2\%$

① Fast repetitive timings (approximately .5 second) will change the accuracy to approximately  $\pm 4\%$  (in percent of setting).

**Supply Voltage Variation**

Voltages between 80% and 110% of nominal will affect the timing accuracy not more than  $\pm 3$  milliseconds for settings 0.3 seconds or less, or  $\pm 1\%$  for settings above 0.3 seconds.

The relay will withstand 110% voltage continuously, over a temperature range of  $-40^{\circ}\text{C}$  to  $100^{\circ}\text{C}$ .

**Ambient Temperature**

See Figure 17.

### Time Delay Versus Ambient Temperature

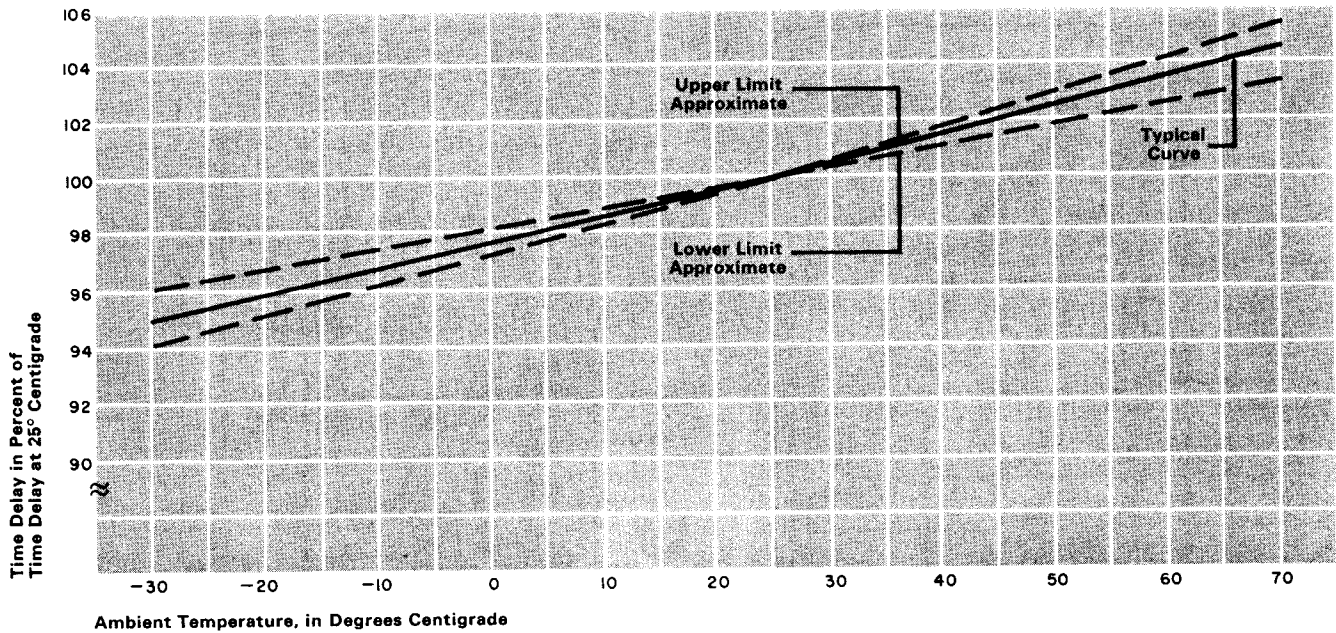

Fig. 17 187A526

### TD-5 Internal Wiring FT-11 Case (Front View)

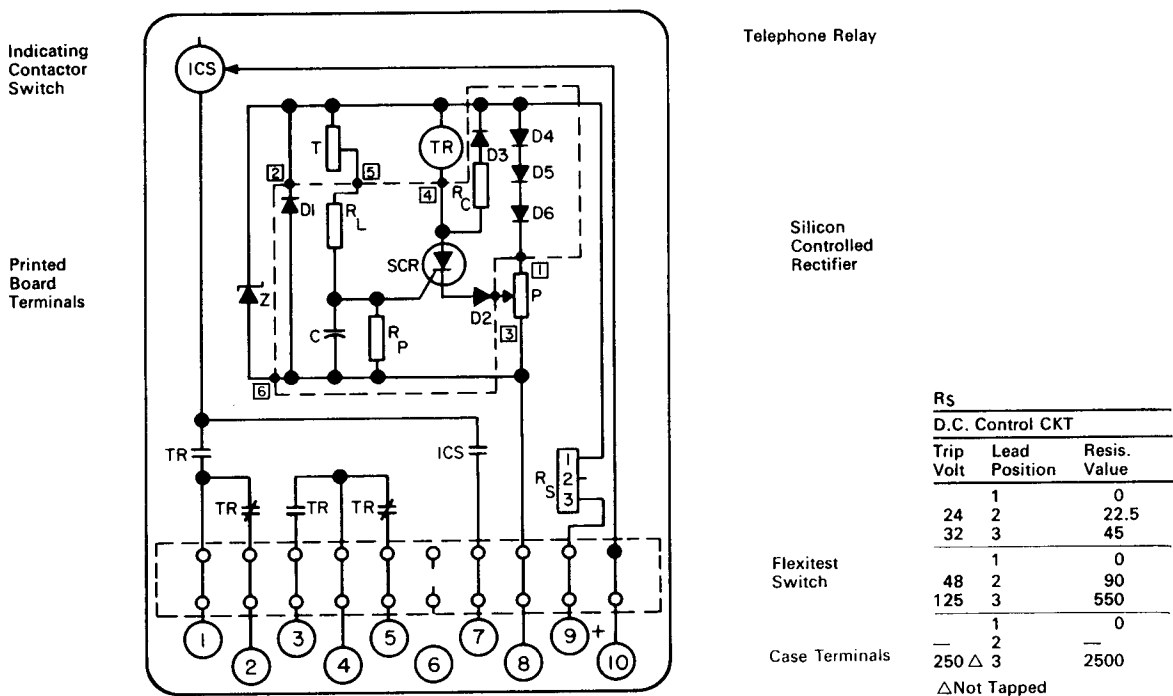

Fig. 18 187A293

Rs		
D.C. Control Ckt		
Trip Volt	Lead Position	Resis. Value
24	1	0
32	2	22.5
	3	45
Flexitest Switch		
	1	0
	2	90
	3	550
Case Terminals		
250	△	2500

△Not Tapped

**Internal Wiring (Front View)**

TD-5 With Initiating Telephone Relay TX, FT-11 Case

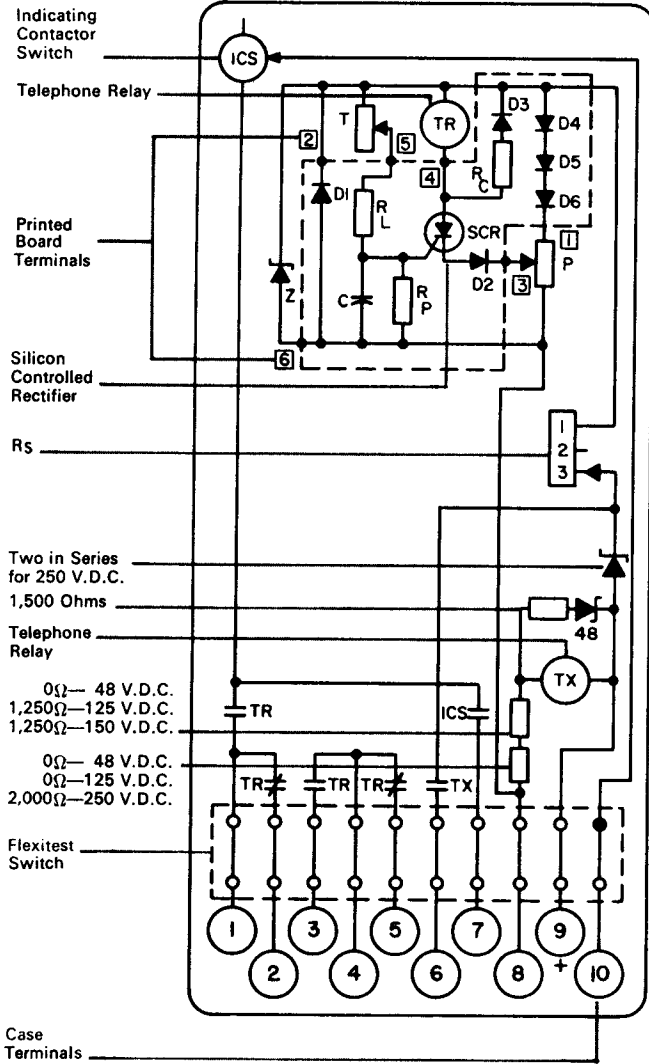

Rs		
D.C. Control CKT.		
Trip Volt	Lead Position	Resis. Value
48	2	90
125	3	550
250	3	2500

Fig. 19 188A016

TD-52, FT-22 Case

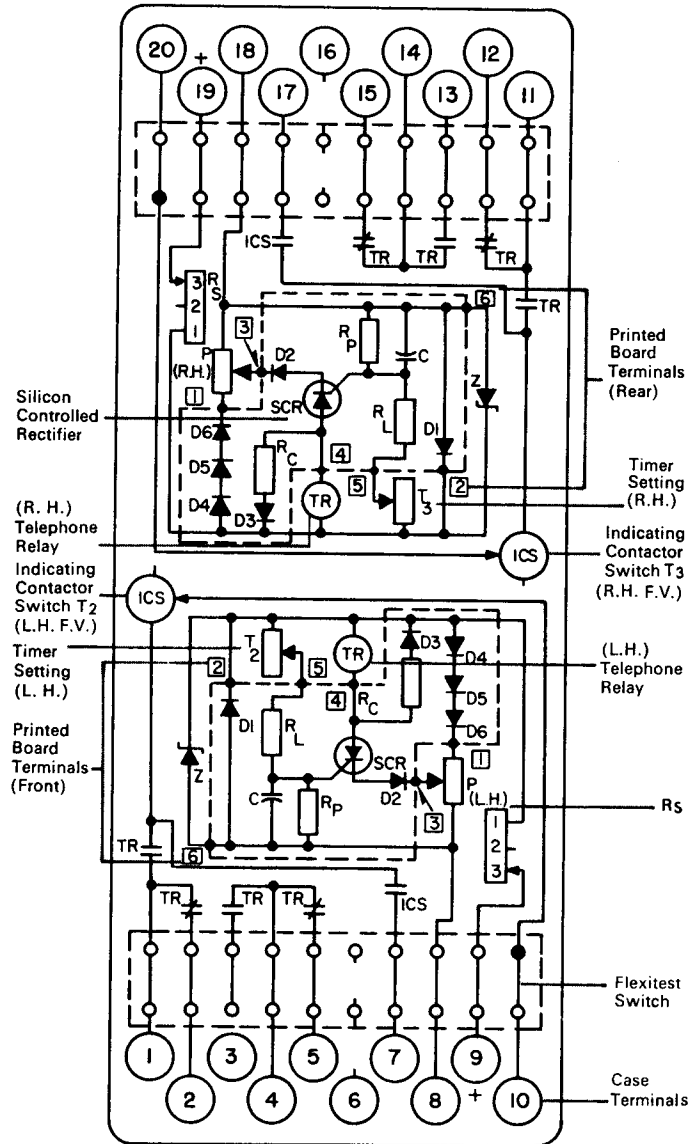

Rs		
D.C. Control Circuit		
Trip Volt	Lead Pos.	Resis. Value
1	0	0
24	2	22.5
32	3	45
1	0	0
48	2	90
125	3	550
1	0	0
—	2	—
250 Δ	3	2500

Δ Not Tapped

Fig. 20 762A500

TD-52 With Double Trip ICS Contacts, FT-22 Case

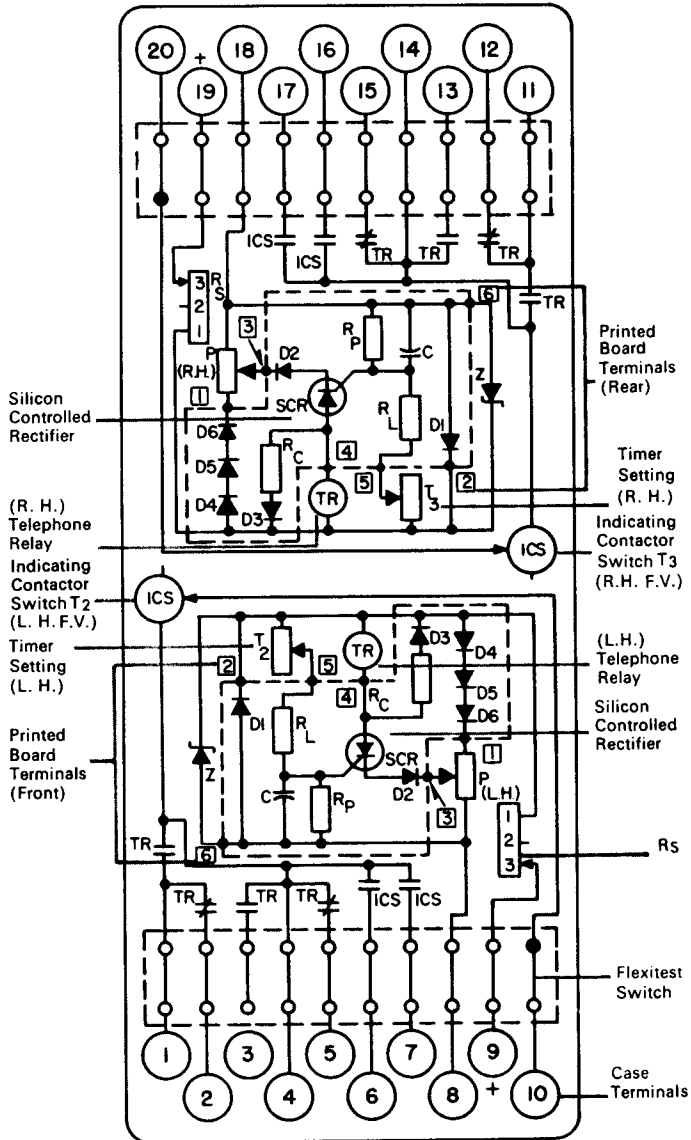

Rs		
D.C. Control CKT		
Trip Volt	Lead Position	Resis. Value
24	1	0
32	2	22.5
	3	45
48	1	0
125	2	90
	3	550
	1	0
250	2	—
	3	2500

△Not Tapped

Fig. 21 629A606

Type TD-50

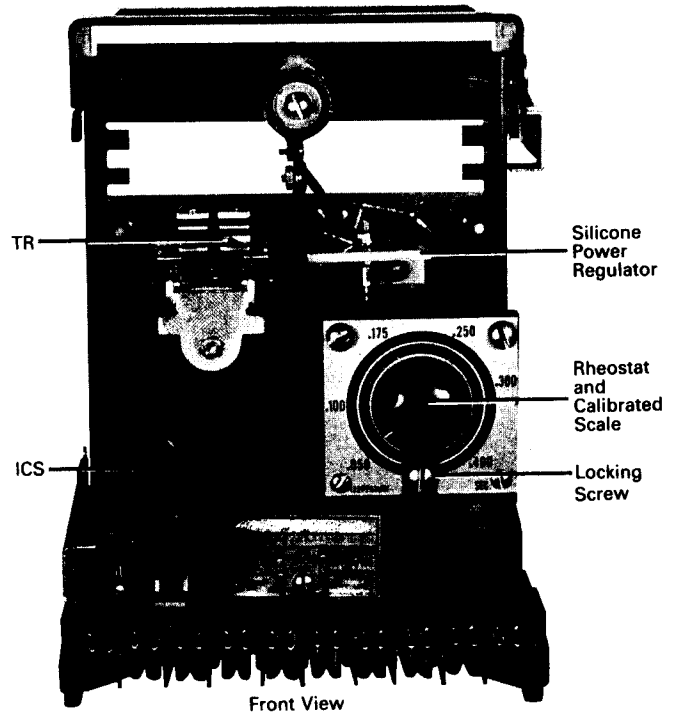

Application

The TD-50 is similar in construction to a type TD-5 except for a transistor starting circuit rather than an external contact.

This relay is for use with other solid-state relays whose output is capable of supplying sufficient base current to drive the TD-50 input transistors into saturation. When used in this manner, the logic may be arranged for use in breaker failure schemes or similar applications where various combination of "AND" and "OR" logic are desired.

Construction

Similar to the type TD-5 timing relay, except with a different printed circuit board containing the necessary switching and logic circuitry.

**Internal Wiring (Front View)**

**TD-50, Single Input Starting, FT-21 Case**

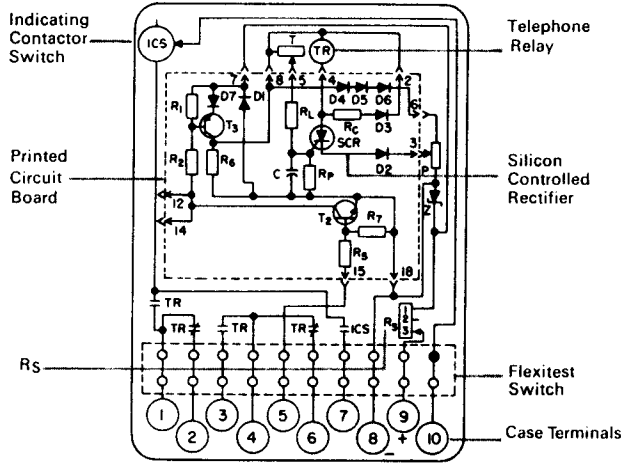

RS			
D.C. Control CKT.			
Trip Volt	Lead Pos.	Resis. Value	
0	1	0	
48	2	90	
125	3	550	

Fig. 22 763A929

**TD-50, Two Input Starting, FT-21 Case**

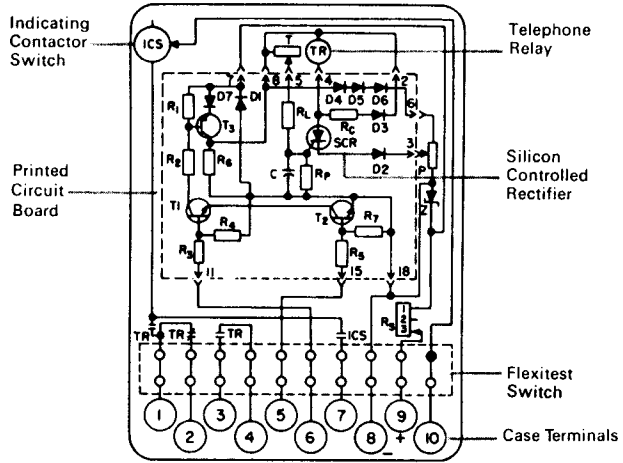

RS			
D.C. Control CKT.			
Trip Volt	Lead Pos.	Resis. Value	
0	1	0	
48	2	90	
125	3	550	

Fig. 23 764A264

**TD-50, Three Input With Two Input Starting, FT-21 Case**

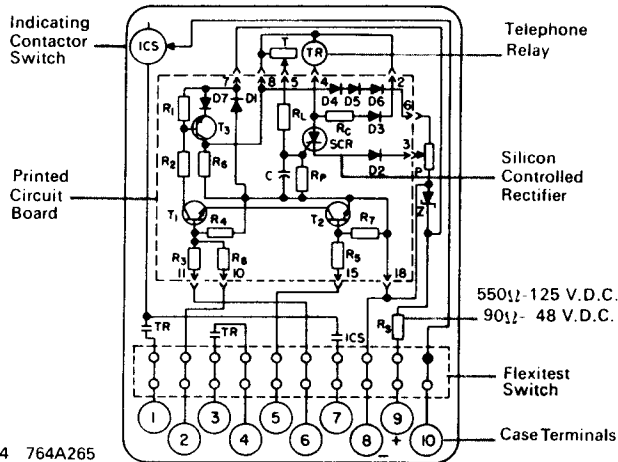

Fig. 24 764A265

**TD-50, Three Input With Two Input Starting and Seal-In Circuit, FT-21 Case**

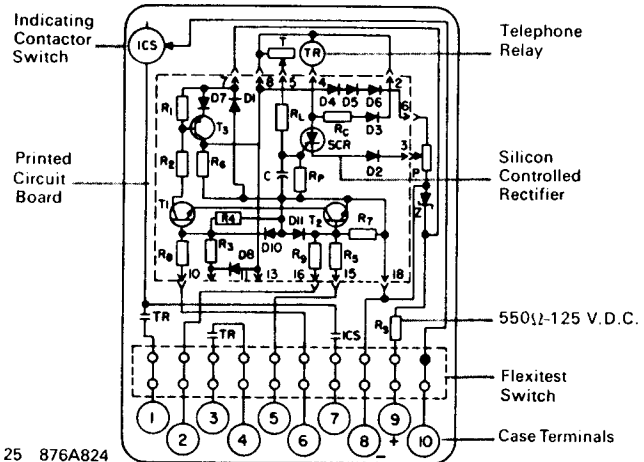

Fig. 25 876A824

**Carton Weights and Shipping Dimensions**

Case Type	Relay Type	Weight: Pounds		Domestic Shipping Carton Dimensions: Inches
		Net	Shipping	
FT-11	TD-5	8	10	9 x 9 x 10
FT-21	TD-4	15	13	9 x 12 x 13
	TD-50	12	16	9 x 12 x 13
	TK	12	16	9 x 12 x 13
FT-22 Square Metal	TD-52	..	..	9 x 12 x 13
	TK	10	14	9 x 9 x 10

**Further Information**

List Prices: PL 41-020  
 Technical Data: TD 41-025  
 Instructions: TK—IL 41-574.1 TD-50—IL 41-579.2  
 TD-4—IL 41-579 TD-52—IL 41-579.3  
 TD-5—IL 41-579.1  
 Flexitest Cases: DB 41-076  
 Other Cases: DB 41-080  
 Dc to Ac Inverter: DB 41-082  
 Other Protective Relays:  
 Application Selector Guide, TD 41-016

Printed in U.S.A.





August, 1991  
Supersedes TD 41-020, Types TK, TD-4,  
TD-5, TD-50 and TD-52 on pages 84 and 85,  
dated November, 1987  
Mailed to: E, D, C/41-500A

For Ac and Dc Applications  
Requiring A Definite Time Delay

# Types TK, TD-4, TD-5, TD-50 and TD-52 Timing Relays

## Timing Relays (Device Number: 2)

Type	Time Range		Seal-in Contact	Frequency	Volts	Relay Data		
	Reset Stroke	Energized Stroke				Internal Schematic	Style Number	Case Size
<b>Square Metal Case (Projection Mounted)</b>								
TK ①	Quick	2 Sec. to 50 Min.	Without	60 Hertz	115	56D806	1877 892	5 1/2" square
					208		1956 243	
					230		1877 893	
					460		1877 894	
					575		1877 897	
					Dc②		125	
	250	1956 240						
	With	60 Hertz	60 Hertz	115	56D807	1877 904		
				208		1956 244		
				230		1877 905		
				460		1877 906		
				575		1877 909		
Dc②				125		183A901	1956 242	
250	1956 241							
<b>Flexitest Case</b>								
	Quick	2 Sec. to 50 Min.	Without	60 Hertz	115	57D7908	1876 009	FT-21
					208		1956 238	
					230		1876 010	
					460		1876 011	
					575		1876 012	
					Dc②		125	
	250	1956 067						
	With	60 Hertz	60 Hertz	115	57D7909	1876 014		
				208		1956 239		
				230		1876 015		
				460		1876 016		
				575		1876 017		
Dc②				125		183A208	1876 018	
250	1956 068							

Type	Timing Range: Seconds		Dc Voltage	Output Contact Circuits	TX Units	Reset Time	Relay Data		
	Min.	Max.					Internal Schematic	Style Number	Case Size
TD-4	Zone 2	0.1-1.0	48/125/250	Common	2	.06 sec. or less	184A615	644B301A09⑤	FT-21
	Zone 3			Independent			185A232	644B301A10⑤	
	Zone 2	0.5-3.0		Independent	837A071	644B301A19			
	Zone 3			Common	185A210	644B301A17			
	Zone 2	0.1-1.0	Independent			837A071	644B301A18		
	Zone 3					0.3-1.5			

## Dc to Ac Inverter (DB 41-082)

Output Volt-Amperes: Ac	Conversion Factor	Applied with Relay Type:	Style Number
0-3 va	125/250 volts dc to 115 volts	TK	1008 561
0-8 va	60 Hertz③	RC	1008 549

⑤ Denotes item available from stock.  
① 50 Hertz relays and auxiliaries can be supplied at same price. Order "Similar to Style Number . . . . ., except 50 Hertz".

③ For 125 or 250 volt dc operation, order dc to ac inverter from table above. Potentiometer required on 250 volt operation.

⑤ For conversion from 250 volts dc, order 8 1/2" long, 160 watt, 1825 ohm potentiometer (with mounting bracket) style number 07B4865G17. Outline dimensions per DB 41-082.



Timing Relays, Continued

Type	Timing Range: Seconds	Rating: Dc Volts	TX Units	Indicating Contactor Switch <sup>Ⓢ</sup>	Relay Data		
					Internal Schematic	Style Number	Case Size
TD-5  One unit per case  Time delay on pickup	.05-0.4	24/32	None	0.2/2.0 amps dc	187A293	293B301A21	FT-11
		48/125				293B301A22 <sup>Ⓢ</sup>	
		48/125	250	One		188A016	293B301A23
			250				293B301A30
	0.5-1.0	24/32	None		187A293		293B301A09
		48/125					293B301A10 <sup>Ⓢ</sup>
		48/125	250	One		188A016	293B301A11
			250				293B301A24 <sup>Ⓢ</sup>
	0.2-4.0	24/32	None		187A293		293B301A12
		48/125					293B301A13 <sup>Ⓢ</sup>
		48/125	250	One		188A016	293B301A14
			250				293B301A25
1.5-30.0	24/32	None		187A293		293B301A15	
	48/125					293B301A16 <sup>Ⓢ</sup>	
	48/125	250	One		188A016	293B301A17	
		250				293B301A26	
With Avalanche Diodes	.05-0.4	48/125	One	0.2/2.0 amps dc	876A763	293B301A37	
		250				293B301A38	
	.05-1.0	48/125					293B301A33
		250					293B301A35
.2-4	48/125					293B301A39	
1.5-30	48/125					293B301A34	
TD-50 2 input start	.05-0.4	48/125	With	0.2/2.0 amps dc	3504A92	774B872A09	
		48/125				774B872A11	
	.05-1	48/125					774B872A12
		250					774B872A10
TD-52  Two timing ranges per case	.05-.04	24/32	None	0.2/2.0 amps dc	629A606	606B038A09	
		48/125				606B038A10	
		48/125	250	None		629A606	606B038A11
			250				606B038A17
	.05-1.0	24/32	None				606B038A18
		48/125					606B038A19
		48/125	250	None		629A606	606B038A25
			250				606B038A26
0.2-4.0	24/32	None				606B038A27	
	48/125					606B038A29	
	48/125	250	None	1.0 amp dc	849A147	606B038A29	
		250				606B038A33	
1.5-30.0	24/32	None		0.2/2.0 amps dc	629A606	606B038A34	
	48/125					606B038A35	
	48/125	250				606B038A35	
		250				606B038A35	
TD-53	.05-1.0	125	None	0.2/2.0 amps dc	764A246	644B297A15	
		125				644B297A20	
	0.2-4.0	250					644B297A21

Ⓢ Denotes item available from stock.

Ⓢ ICS: Indicating Contactor Switch (dc current operated) having seal in contacts and indicating target which are actuated when the ICS coil is energized at or above

pickup current setting. Suitable for dc control voltages up to and including 250 volts dc. Two current ranges available:

- (1) 0.2/2.0 amps dc, with tapped coil.
- (2) 1.0 amp dc, without taps.

Rating of ICS unit used in specific types of relays is shown in price tables. All other ratings must be negotiated.

When ac current is necessary in a control trip circuit, the ICS unit can be replaced by an ACS unit.

The ACS unit may be supplied in place of an ICS unit at no additional cost. Specify system voltage rating on order.

ABB Power T&D Company Inc.  
Relay Division  
4300 Coral Ridge Drive  
Coral Springs, FL 33065  
954-752-6700



ABB Power T&D Company Inc.  
Relay Division  
7036 Snowdrift Road, Suite 2  
Allentown, PA 18106  
610-395-7333

Printed in U.S.A.