

MEDIUM VOLTAGE PRODUCT

TJP 6.0-G

Indoor voltage transformers



Parameters	Units
Highest voltage for equipment	3.6 – 24 (25) kV
Power frequency test voltage, 1 min.	10 - 60 kV
Lightning impulse test voltage	40 - 125 kV
Max. rated burden, classes	50/0.2 - 150/0.5 - 200/1 VA/cl
Residual winding	50 - 200/6P VA/cl

Description

The TJP 6.0-G epoxy insulated voltage transformers are cast in epoxy resin and designed mostly for insulation voltages of 3.6 to 24(25) kV.

If no a different value is required the transformers are manufactured with a overvoltage factor of $1.9 \times U_n/8$ hrs. One outlet of the primary winding, including the respective terminal is insulated from the earth to a level which corresponds to the rated insulation value. The other outlet of primary winding with its terminal is earthed during the operation. Most of the transformers are equipped with two secondary windings, the first one for either measuring or protection purposes, the other for being connected into an open-delta connection in a three-phase system. One terminal of each secondary winding and one of the opendelta connected terminals have to be earthed during the transformer operation.

The secondary windings are lead out into a cast-type secondary terminal board. The secondary terminal board is covered with a sealed plastic cover.

The transformer can be mounted in any position. The transformer body is fixed by four screws.

The TJP 6.0-G transformer is equipped with a fuse conformably to IEC standard. The design of TJP 6.0-G is suitable for the „cable“ connection

Rated primary voltages

3 000/ $\sqrt{3}$; 6 000/ $\sqrt{3}$; 6 600/ $\sqrt{3}$; 10 000/ $\sqrt{3}$; 10 500/ $\sqrt{3}$; 11 000/ $\sqrt{3}$; 11 500/ $\sqrt{3}$; 13 800/ $\sqrt{3}$; 14 000/ $\sqrt{3}$; 14 400/ $\sqrt{3}$; 14 500/ $\sqrt{3}$; 15 000/ $\sqrt{3}$; 15 750/ $\sqrt{3}$; 16 000/ $\sqrt{3}$; 16 500/ $\sqrt{3}$; 17 000/ $\sqrt{3}$; 18 000/ $\sqrt{3}$; 18 500/ $\sqrt{3}$; 19 000/ $\sqrt{3}$; 19 200/ $\sqrt{3}$; 20 000/ $\sqrt{3}$; 21 000/ $\sqrt{3}$; 22 000/ $\sqrt{3}$; 24 000/ $\sqrt{3}$ V
Other primary voltages can also be supplied on request.

Rated secondary voltages

100/ $\sqrt{3}$; 110/ $\sqrt{3}$; 115/ $\sqrt{3}$; 120/ $\sqrt{3}$; 190/ $\sqrt{3}$ V – accuracy classes 0.2; 0.5; 1 (measuring winding) or 3P; 6P (protection winding).
Other secondary voltages can also be supplied on request.

Rated voltages for open-delta connection

100/ $\sqrt{3}$; 110/ $\sqrt{3}$; 115/3; 120/3; 190/3 V - class 6P.
Other voltages for open-delta connection can also be supplied based on customer requirement.

Rated frequency

50 Hz; 60 Hz.

Based on a discussion with the manufacturer the transformer can also be provided with primary winding designed for two different primary voltages (with secondary side changeover).

The transformers are manufactured conformably to the requirements and recommendations of the following standards and regulations: IEC, VDE, ANSI, BS, GOST and CSN.

Dimensional Drawings

TJP 6.0-G
Dimensions for
short baseplate

Weight: appr. 42 kg
Creepage Distance: 536 mm

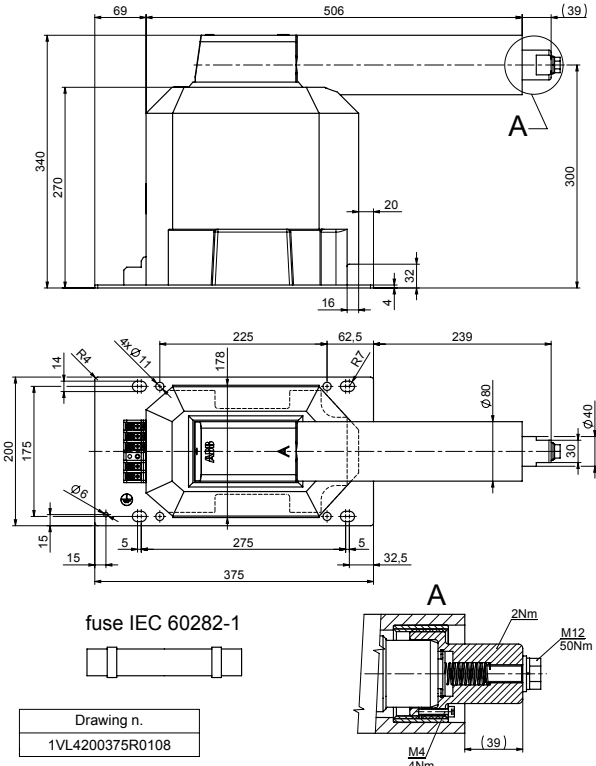

TJP 6.0-G
Dimensions for
long baseplate

Weight: appr. 43 kg
Creepage Distance: 536 mm

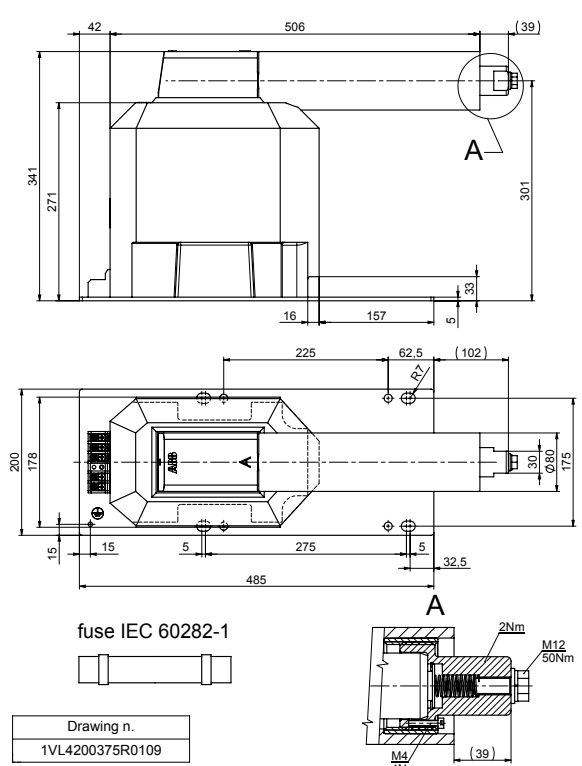

Marking of the voltage transformer outlets

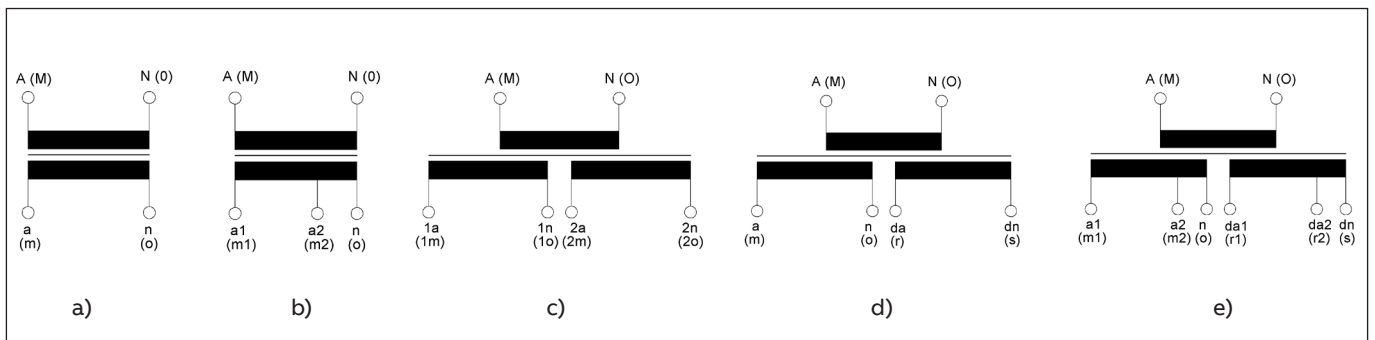

- a) Single-pole insulated transformer
- b) Single-pole insulated transformer with a tap
- c) Single-pole insulated transformer with two secondary windings
- d) Single-pole insulated transformer with two secondary windings, with one of which being the auxiliary (residual) winding
- e) Single-pole insulated transformer with two secondary, tapped windings, with one which being the auxiliary (residual) winding.

CONTACT US

ABB s.r.o.

ELDS Brno

Videnska 117, 619 00 Brno,
Czech Republic

Tel.: +420 547 152 021

+420 547 152 854

Fax: +420 547 152 626

E-mail: kontakt@cz.abb.com

www.abb.com

NOTE

We reserve the right to make technical changes or modify the contents of this document without prior notice. With regard to purchase orders, the agreed particulars shall prevail. ABB does not accept any responsibility whatsoever for potential errors or possible lack of information in this document.

We reserve all rights in this document and in the subject matter and illustrations contained therein. Any reproduction, disclosure to third parties or utilization of its contents - in whole or in parts - is forbidden without prior written consent of ABB.

Copyright© 2024 ABB
All rights reserved