

APPLICATION NOTE

# Intelligent data needs intelligent power

## Current and power monitoring can be directly integrated into tap-off units

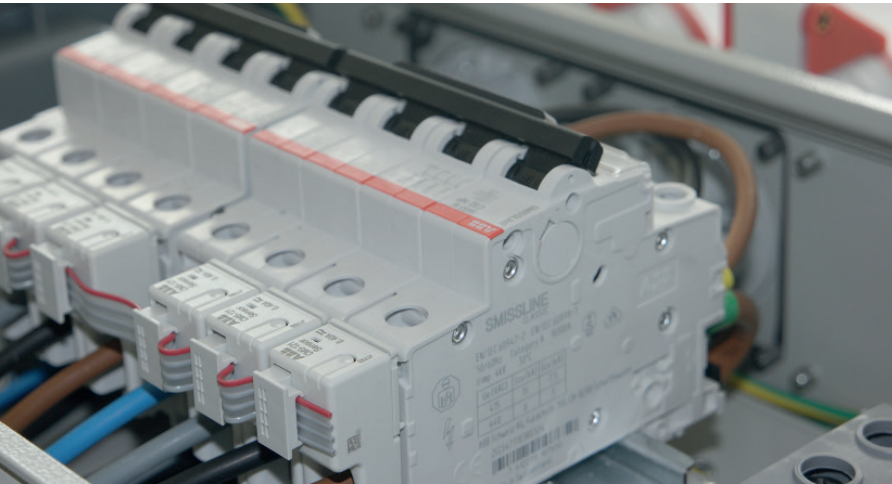

Ever wondered if you could integrate current and power monitoring into your existing tap-off unit portfolio? With our new CMS range, you can fit tiny current sensors directly on the breaker without using any additional Din rail space.

—  
01 CMS integrated into tap-off units

### Application principle

Energy efficiency is becoming increasingly important for critical power applications such as data centers. But you cannot improve what you cannot measure.

As the most compact AC and DC multichannel branch monitoring system, the Circuit Monitoring System (CMS) provides a reliable solution for measuring individual branch load circuits and presenting energy and power dashboards. Perfectly fitting into tap-off units feeding the server racks, the CMS is an efficient and flexible solution for mains and branch measurement in mission critical installations.

Tap-off units equipped with the Circuit Monitoring System ensure optimal load distribution and efficient energy consumption. In addition, the solution protects data centers against current-related system outages with an integrated alarm function.

### Main values

- Increased flexibility: Easy to extend when expanding the busbar trunking system
- Time and space saving: No additional space requirement in the tap-off boxes thanks to compact, bus-wired sensors mounted directly on the MCBs
- User-friendly: easy configuration without external software

### Detailed solution description

Mounted overhead or under the raised floor of the server racks, the busbar trunking system is equipped with master and slave plug-in tap-off units.

The master tap-off unit measures the incoming side with the CMS-700 Control Unit inside the box and optional current transformers at the busbar feeder. With the voltage and power factor measurements at the mains, the Control Unit calculates active power and energy for the branches. Up to 96 (3x32) sensors can be connected to one CMS-700 Control Unit via three ribbon buses. With the integrated webserver the Control Unit visualizes online and historical values of current, voltage, THD (U, I), power factor and energy.

CMS open-core current sensors are integrated into daisy-chained slave tap-off units and measure the current of every single phase to the rack PDU. They are easily mounted on the MCBs and are tidily bus-wired with a ribbon cable.

The CMS supports a variety of communication protocols like Modbus and SNMP and thus allows the integration into higher level systems like a DCIM or SCADA. The integrated webserver ensures an easy configuration and allows you to remotely check real-time online values as well as historical data without any additional external software.

The solution is perfectly suitable for new and existing installations in critical power applications like data centers as well as industrial and manufacturing environments.

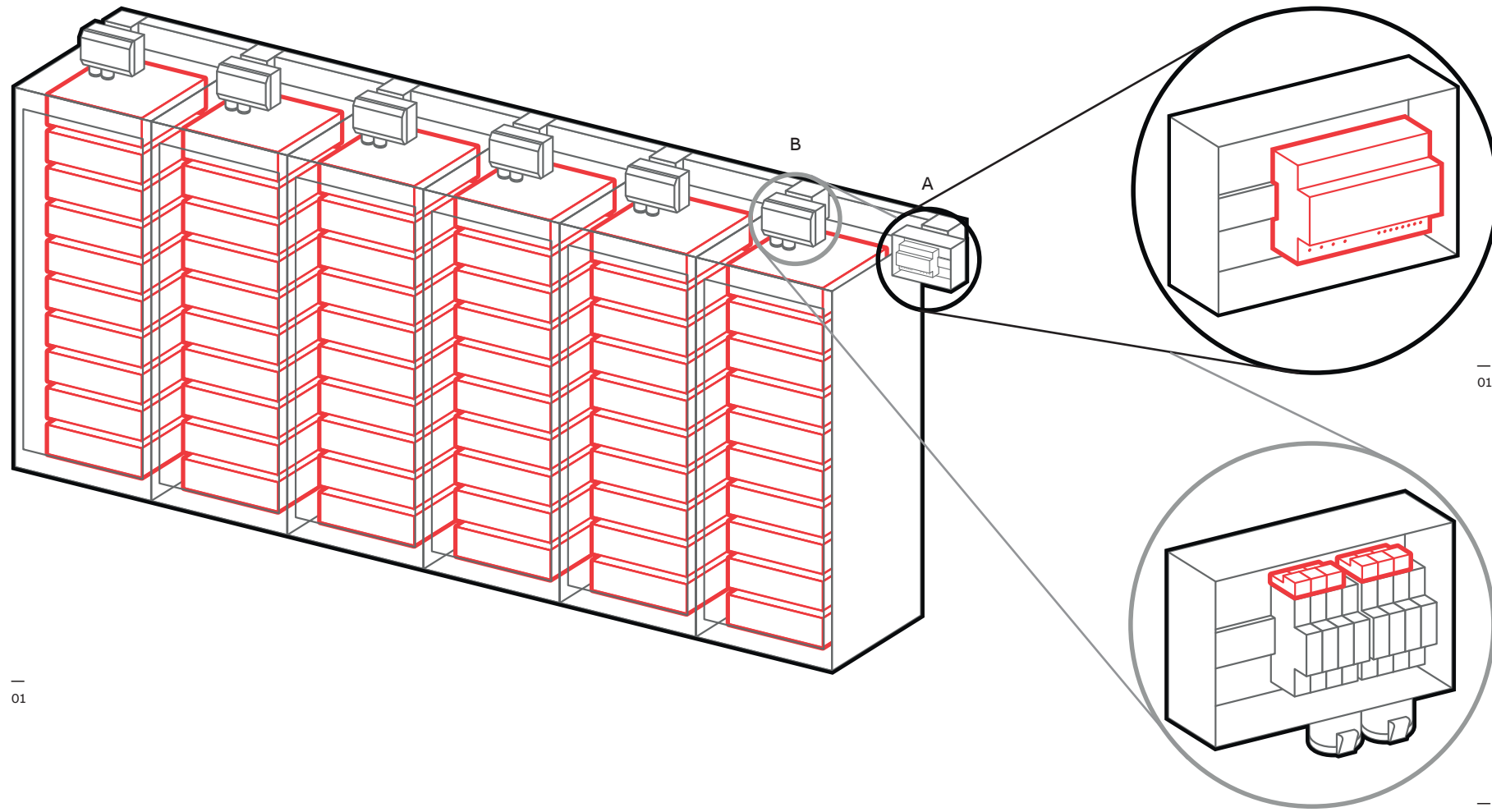

01

01

02

### Master Tap-Off Unit

Product	Order code	Quantity*
Control Unit CMS-700	2CCA880700R0001	1
CMS Flat Cable 2m	2CCA880148R0001	1
S203M-C6NA MCB	2CDS273103R0064	1
CT PRO XT 250	2CSG225815R1101	4
M 16/12.P Rail mounted terminal	1SNA165130R2300	1
M 16/12.N Rail mounted terminal	1SNA125129R1600	1

\*One tap-off unit for three channels

### Slave Tap-Off Unit

Product	Order code	Quantity*
S203M-C32NA MCB	2CDS273103R0324	10
Current Sensor CMS-121PS	2CCA880211R0001	30
CMS Connector Set	2CCA880145R0001	1
CMS Flat Cable 2m	2CCA880148R0001	3
CEE Socket 432RU6	2CMA193259R1000	10
M 16/12.P Rail mounted terminal	1SNA165130R2300	10
M 16/12.N Rail mounted terminal	1SNA125129R1600	10

\*One tap-off unit for one channel



Further information:  
<http://goo.gl/vKOEyt>

01 Master tap-off unit  
02 Slave tap-off unit

01 Tap-off units  
feeding server racks  
[A] Master Tap-Off Unit  
[B] Slave Tap-Off Unit

Technical features	Benefits
<ul style="list-style-type: none"> <li>Modular system to connect up to 96 sensors into new or existing installations</li> <li>Tidy bus wiring of the CMS sensors within the tap-off unit</li> <li>Daisy chained tap-off units with T-adapters for regular RJ45 Ethernet cables</li> <li>Open-core sensors can be mounted directly without interrupting the outgoing feeder</li> <li>Alarm and event handling system</li> </ul>	<ul style="list-style-type: none"> <li>Easy to extend when expanding the busbar trunking system</li> <li>Low space requirement inside the tap-off unit</li> <li>No time-consuming single wiring of each sensor</li> <li>Maintenance without interrupting any communication of each CMS-bus thanks to the possibility to disconnect the boxes individually</li> <li>Retrofit into the existing installations without any additional space requirements</li> <li>Reduce downtime by early detection of potential issues</li> </ul>

### Detailed product description

#### Control Unit CMS-700



With the integrated webserver, the Control Unit CMS-700 visualizes online and historical values like current, voltage, power factor, THD, energy. Thanks to its three bus interfaces, up to 3x32 sensors can be connected to the Control Unit. Maximum data security and reliability is guaranteed by the communication protocols Modbus RTU, TCP/IP and SNMP v1/2 and the encrypted version 3.

#### Current transformer



Optimized dimensions make the CTs extremely flexible and adaptable to any kind of application and allow easy handling during maintenance operation.

Double method for connecting the secondary winding thanks to the introduction of screwless terminals rather than screw terminals.

#### MCB with open-core sensor



The very compact current sensors are mounted directly on the MCBs which saves space on the DIN rail. All sensors are bus-wired instead of cumbersome star wiring.

#### Industrial sockets



With a compact, robust design, the industrial sockets are easy to access and easy to install. High precision pins and machine calibrated sleeves with stainless steel spring provide sufficient contact pressure over time.

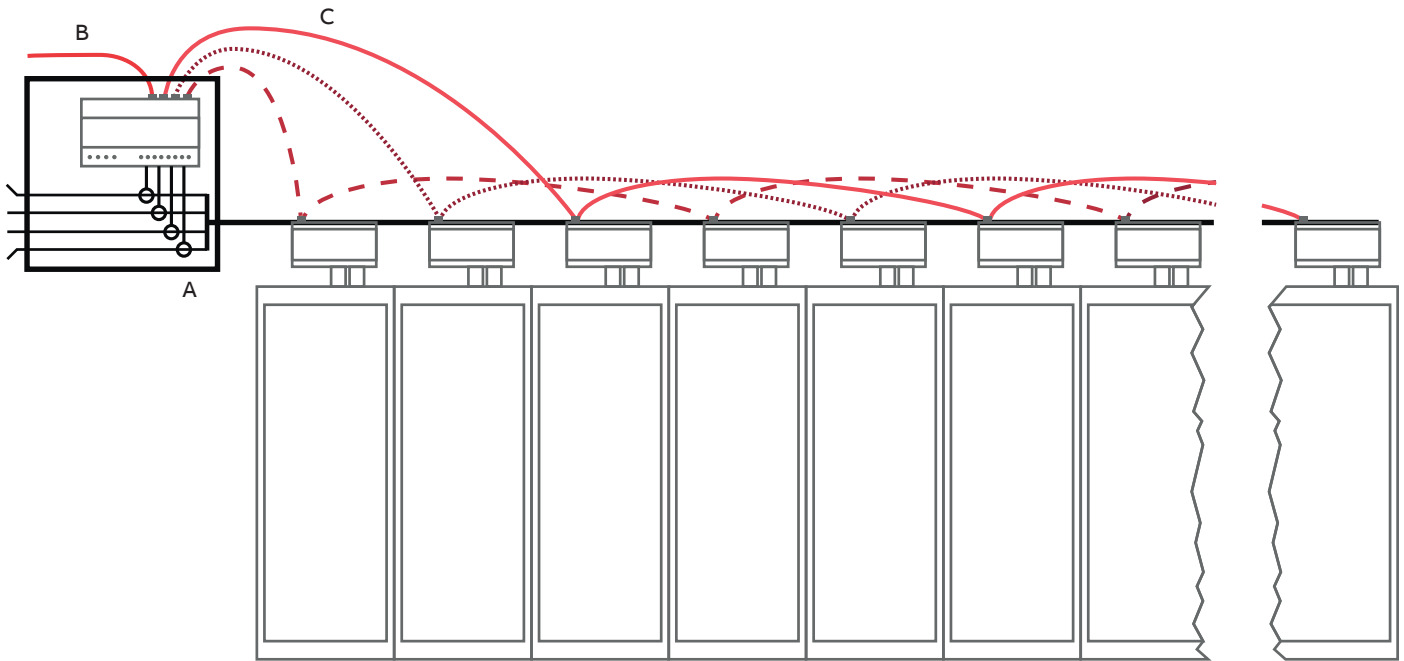

—  
01

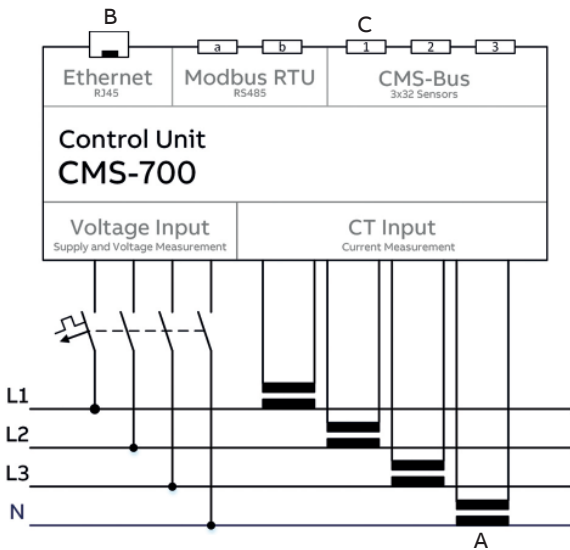

—  
02

Mains current transformers (CTs) [A] measure the phases L1, L2, L3 with optional N and are connected to the CMS-700 Control Unit inside the master tap-off unit. An RJ45 or RS485 interface [B] is available to read out the measured values. The three CMS buses [C] on top of the Control Unit are wired out of the master box to RJ45 sockets. From there each of the three buses is daisy-chained to the subsequent slave tap-off units with open-core sensors.

—  
01 Installation principle for CMS in tap-off units  
—  
02 Wiring diagram

All slave tap-off units have an RJ45 socket to daisy-chain them along the busbar trunking system with an Ethernet cable and an optional T-adapter to avoid communication interruptions during maintenance work. Due to redundancy advantages, the daisy-chain principle is recommended as follows if using e.g. 6 sensors per slave box:

- CMS-bus 1 is connected to slave tap-off units 1, 4, 7, 10, 13.
- CMS-bus 2 is connected to slave tap-off units 2, 5, 8, 11, 14.
- CMS-bus 3 is connected to slave tap-off units 3, 6, 9, 12, 15.

Any other combination of 1 to 6 sensors in each slave tap-off unit is possible depending on the number of MCBs used.