







Medium Voltage Products

UniMotor

Arc-proof air insulated motor control center

	1
DESCRIPTION	3
	2
MAIN COMPONENTS	11
	3
SPECIFIC PRODUCT CHARACTERISTICS	21
	4
INSTALLATION	25

DESCRIPTION

General information	4
Fields of application	4
Compliance with Standards	5
Normal service conditions	5
Degrees of protection	5
Standard color	5
Main characteristics	5
REF 542 unit	6
Integrated system for motor control	7
Protection against internal arc	8
Fast Recovery	8
Type tests	9
Quality Assurance System	9
Environmental Management System	9
Test laboratory	9
Electrical characteristics	10

DESCRIPTION

General information

UniMotor is a 12kV motor control center combinable with UniSafe or UniVer G12 switchboards. Each unit consists of three superimposed contactor compartments fitted with busbar, feeder and instrument compartments as well as a wiring duct for the auxiliary circuits.

The housing of three contactor compartments in the same unit combines a high number of applications with a substantial reduction of the overall dimensions.

The UniMotor switchboards are equipped with withdrawable V-Contact vacuum contactors and medium voltage protection fuses.

The contactors can be used to operate motors, transformers and capacitor banks. Each cubicle is designed so as to withstand overpressures caused by the internal arc.

The UniMotor is made of aligned standard components. This modular configuration is suitable for the switching of different contactors.

The switchboard also houses the connections between the contactors and the interlocks and operating devices. A high number of standard combinations makes modification, maintenance and extension very easy.

Fields of application

The UniMotor flexibility allows different types of motor switching such as:

- across the line;
- motor reverse operation
- autoreactor
- autotransformer
- star-delta
- motor starting with reduced speed.

UniMotor switchboards can be used to feed and operate also transformers and capacitor banks in power generation plants, transformer and distribution substations, industrial plants and naval applications.

UniMotor switchboard.



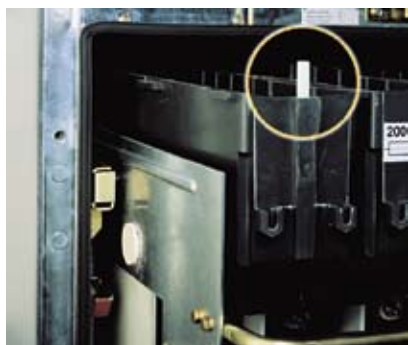

Fuses tripping-locking device.



Contactors in the withdrawn position for the fuses control and replacement.



Contactors racking-in with the door closed.

Compliance with Standards

Switchboard:	IEC 60694 IEC 60298
Earthing switch:	IEC 60129
Contactors:	IEC 60470
Fuses:	IEC 60282-1 CENELEC EN 60282-1

Normal service conditions

Normal operating characteristics are guaranteed under the following conditions:

- minimum ambient temperature – 5 °C
 - maximum ambient temperature + 40 °C
 - maximum relative humidity 95 %
 - maximum altitude 1000 m a.s.l.
- in presence of normal unpolluted atmosphere.

Degrees of protection

IP4X on the external housing
IP2X inside the switchboard

Standard color

The compartment doors and the end sheets are gray RAL 7035, the surface appearance with a semigloss finish.

Main characteristics

UniMotor switchboards are characterized by:

- reduced overall dimensions;
 - contactors racking in and out with the door closed;
 - possibility of manufacturing many different versions and easy extension of existing switchboards;
 - simple inspection and maintenance.
- The apparatus is accessible through doors or removable panels, the contactors can be easily isolated and removed;
- careful selection of materials and subsequent longer operating life;
 - personnel safety ensured by:
 - automatic shutter for segregating the contactor and busbar compartments
 - apparatus earthing for the whole isolation run
 - correct operation ensured by mechanical and electromechanical interlocks
 - wide range of interlock, signaling and control devices.

UniMotor marine version.



DESCRIPTION



REF 542 unit.



REF 542 Plus unit.

REF 542 unit

The REF 542 unit integrates all the switchboard secondary functions in a single, self-checking module. Thanks to its versatile software, the unit meets a wide range of different installation requirements. The remarkable functional efficiency of the REF 542 unit is enhanced by a simple, easy-to-use interface. Thanks to the use of REF 542, each medium voltage UniMotor panel becomes an integrated and independent unit suitable for a variety of functions.

Its main characteristics are:

- integration of all the functions (protection, measurement, control, signaling, interlock, automation and communication) in a single device;
- single interface between switchboard and operator for all the panels: line, transformer, motor, generator, capacitor banks, bus-tie and measurement units;
- standard set of spare parts and accessories in a single hardware unit;

- reduced maintenance. The use of REF 542 drastically reduces the routine maintenance and limits the damages caused by tampering and misuse;
- easy function modification and updating by means of the unit configuration software even when the switchboard is energized.

The advanced technology of UniMotor, along with the outstanding performances of REF 542, ensures a real-time, throughout control of the plant and significantly increases ease of use, with considerable benefits for running costs and efficiency.

The direct connection between apparatus and switchboard control system fully implements the concept of an integrated installation at the highest level.

Integrated motor control system

Communication Protocols

- SPABUS
- LON
- MVB
- MODBUS RTU
- IEC 60870-5-103

Communications cabling

- RS485
- Fiber optic

System Layout

- 1 Single communication gate on single bus
- 2 Double communication gates on redundant bus
- 3 Double communication gates on redundant bus and master units
- 4 Two-system architecture: SCADA and DCS/PCS.

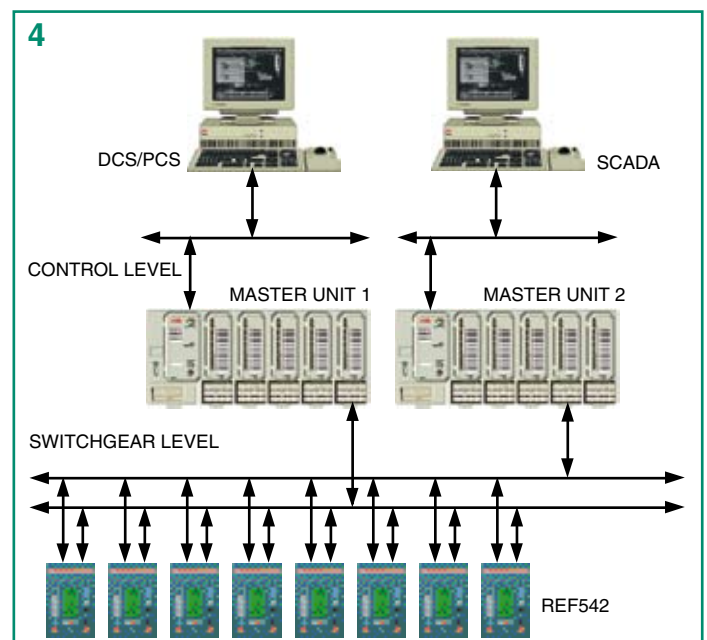
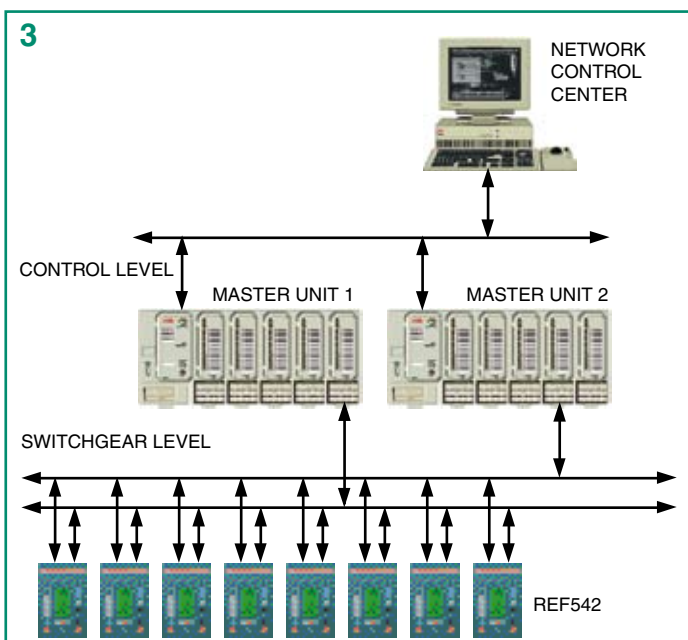
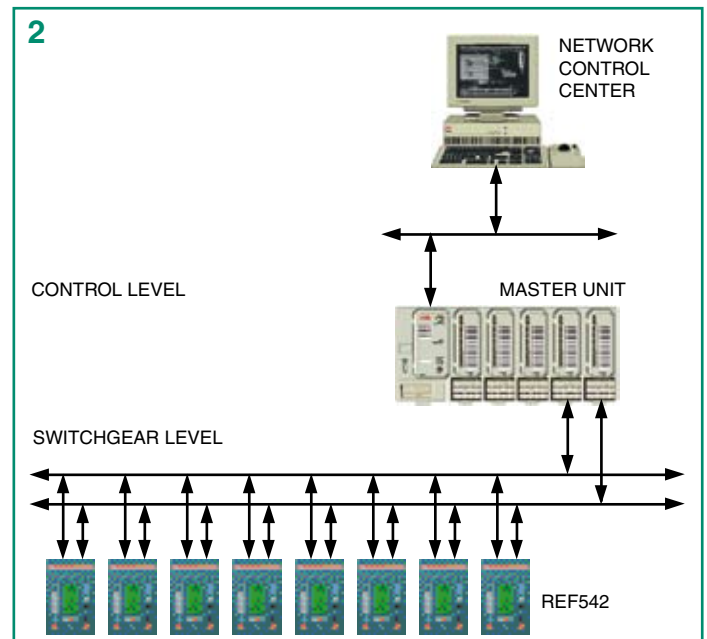
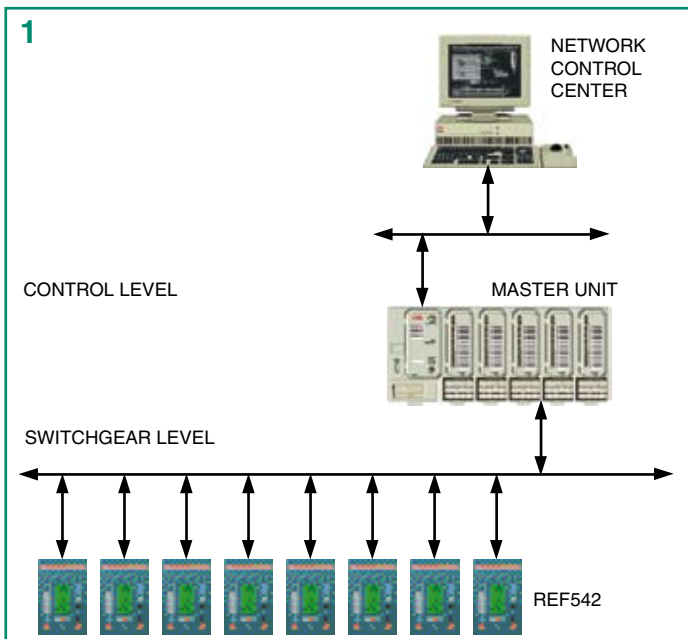

DESCRIPTION

Protection against internal arc

Internal arc is extremely rare occurrence in Uni-Motor switchboards as the compartments are fully segregated from each other and from the external environment.

Anyway, maximum personnel safety is guaranteed even in case of internal arc.

The switchboard is built to withstand the overpressures ensuing from the internal arc and is fitted with ducts to convey the exhausted gases and prevent damages to operators and/or apparatus. The different units are guaranteed arc-proof in compliance with IEC 298, enclosure AA, class accessibility A, criteria 1 to 6.

Fast Recovery

On request, UniMotor can be equipped with Fast Recovery, a specific protection system.

This system is based on pressure sensors properly located in the different compartments and directly connected to the opening releases.

The sensors detect the pressure rise at the moment of the internal arc outburst and promptly trip the upstream protection device.

Thanks to the Fast Recovery System only the part involved in the fault is selectively excluded in less than 100 ms (including the release opening time). A rapid elimination of the fault as well as the metal segregation between compartments and the use of self-extinguishing materials drastically reduces any possible damage.

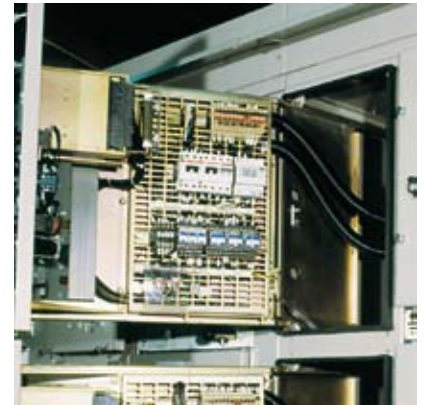

Arc proofing is guaranteed by reinforced doors and a segregated construction.



EMC test laboratory.



Control room and generator room – short circuit test laboratory.

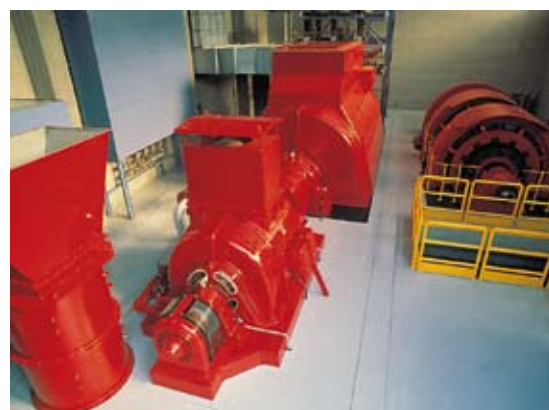

Type tests

The UniMotor switchboards have successfully passed the following type tests in compliance with the IEC 60298 Standards:

- Internal arc test
- Climatic tests under adverse conditions
- Test at the peak and rated short time withstand currents
- Heating test
- Dielectric withstand test.

Quality Assurance System

Certified by an independent organization as complying with ISO 9001 Standards.

Environmental Management System

Certified by an independent organization as complying with ISO 14001 Standards.

Test laboratory

Accredited by independent organization as complying with ISO 45001 Standards.

DESCRIPTION

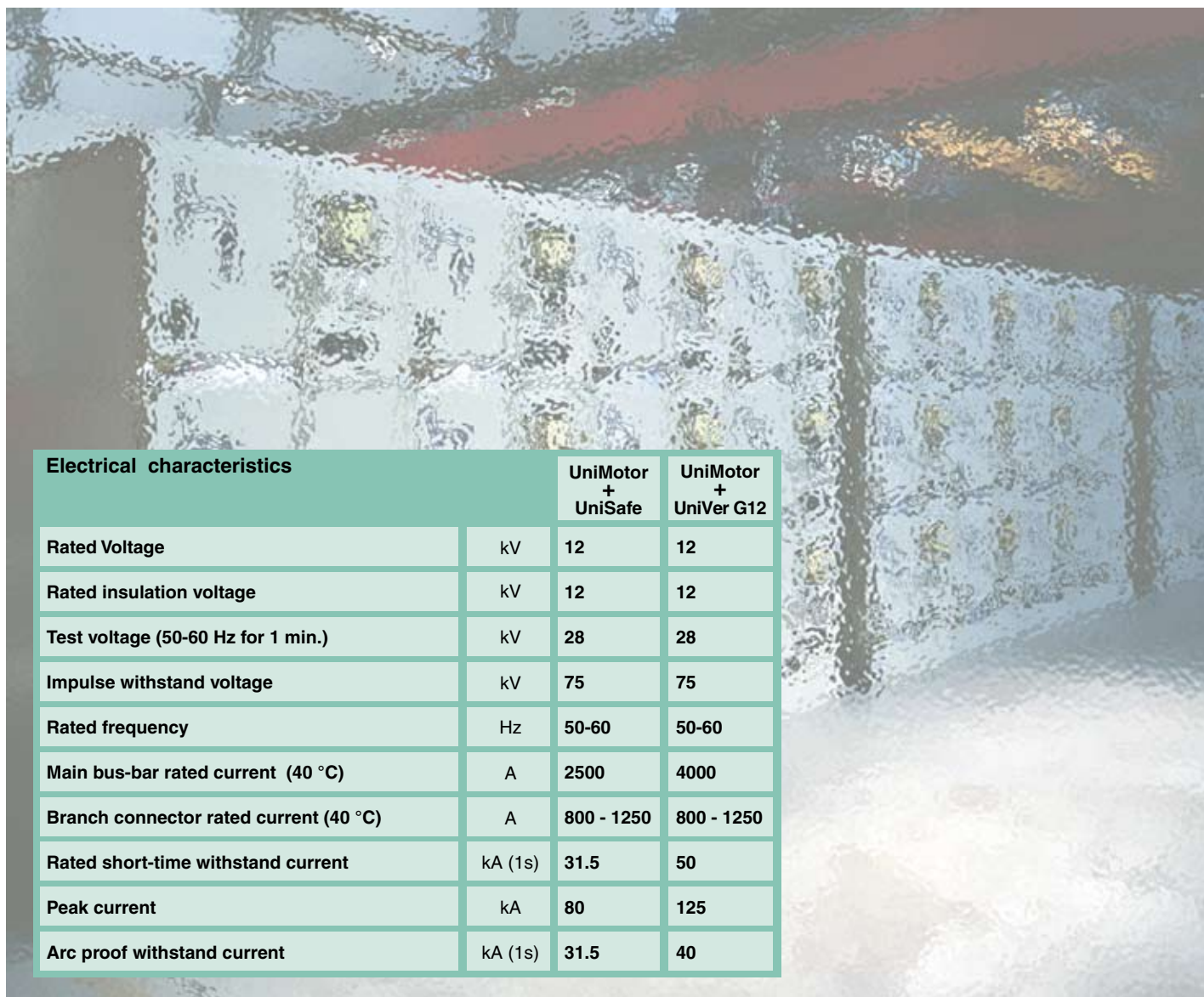

Electrical characteristics		UniMotor + UniSafe	UniMotor + UniVer G12
Rated Voltage	kV	12	12
Rated insulation voltage	kV	12	12
Test voltage (50-60 Hz for 1 min.)	kV	28	28
Impulse withstand voltage	kV	75	75
Rated frequency	Hz	50-60	50-60
Main bus-bar rated current (40 °C)	A	2500	4000
Branch connector rated current (40 °C)	A	800 - 1250	800 - 1250
Rated short-time withstand current	kA (1s)	31.5	50
Peak current	kA	80	125
Arc proof withstand current	kA (1s)	31.5	40

MAIN COMPONENTS

Basic unit components	12
Contactors	14
UniMotor enclosure	16
Main busbars	18
Branch connectors	18
Busbars coating	18
Earthing	18
Terminals	18
Auxiliary instruments	18
Accessories	19
Typical switchboard and contactor diagrams	20

MAIN COMPONENTS

Basic unit components

Each UniMotor unit consists of three superimposed contactor compartments and their relevant auxiliary compartments. Each unit compartment is fully earthed and segregated by metal panels.

A - Wiring duct. On request, the front side of the compartment top can be fitted with an internal wiring duct for the connections between cubicles and external apparatus. The duct is provided with upper outlets.

B - Instrument compartment. The instrument compartment can house all the low voltage equipment, especially the REF 542 unit and other auxiliary accessories.

C - Contactor. The enclosure is equipped with an arc-proof door. A small window makes it possible to inspect the contactor on/off positions and to read the operation counter. The enclosure houses the following components:

- V-Contact vacuum contactor on withdrawable truck (**D**)
- isolators between the busbar compartment and the enclosure;
- monobloc with cable terminals;
- metal automatic shutters for the segregation between contactor and busbar compartments;
- earthing switch (on request);
- truck racking-in device complete with guides and locks;
- auxiliary position contacts of the truck (connected/isolated).

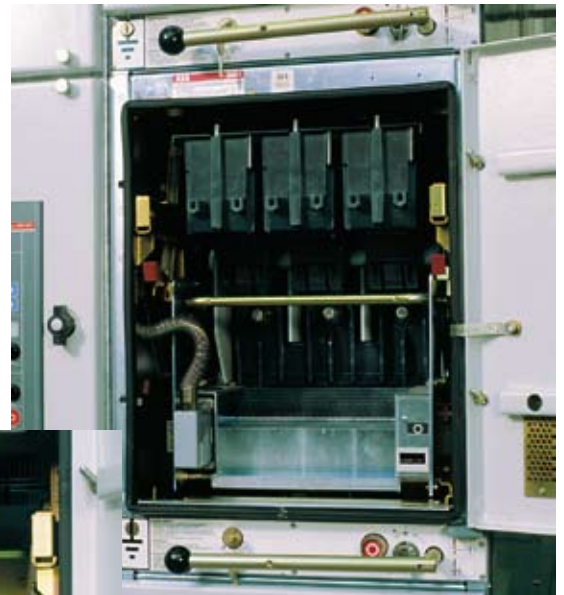

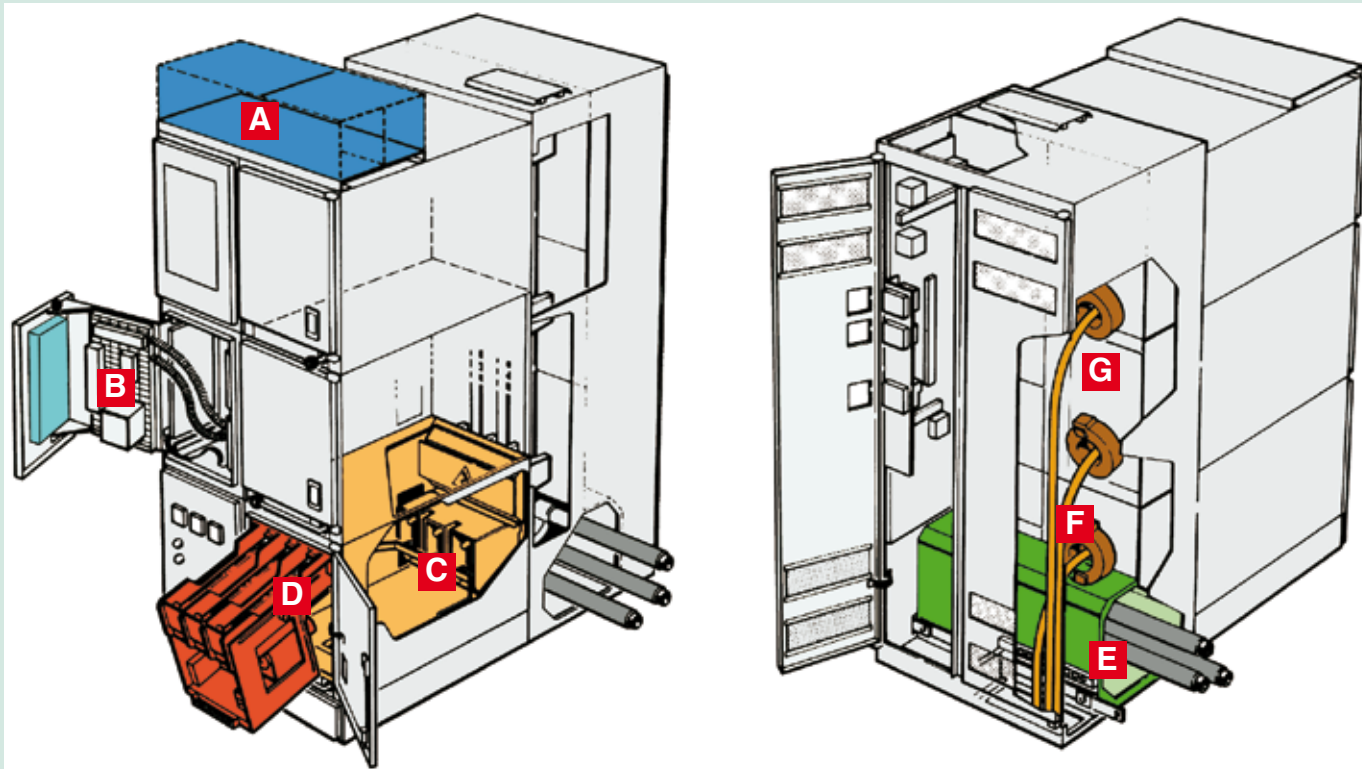

A Wiring duct
B Instruments
C Contactor

D Contactor test position
E Busbars
F Cables
G Line

N.B. The figure shows the UniMotor version to be coupled with the UniVer G12 switchboard.

E - Main busbar compartment and branch connections. The main busbar system is mounted on post insulators. The contactor and cubicle power-supply busbars are vertically shunted from the main busbars. Metal segregation is provided for the branch connections.

F - Cable compartment. The cable compartment is accessible through the rear door. Toroidal transformers can be installed on the cables. The unit is provided with incoming and outgoing passages for the power cables.

G - Feeder compartment. UniMotor switchboard houses three feeder compartments accessible from the rear (one unit for each line). Each feeder compartment is made accessible by removing the rear segregation sheet thus making it possible to work on the de-energized unit without service stops in the nearby compartments.

MAIN COMPONENTS

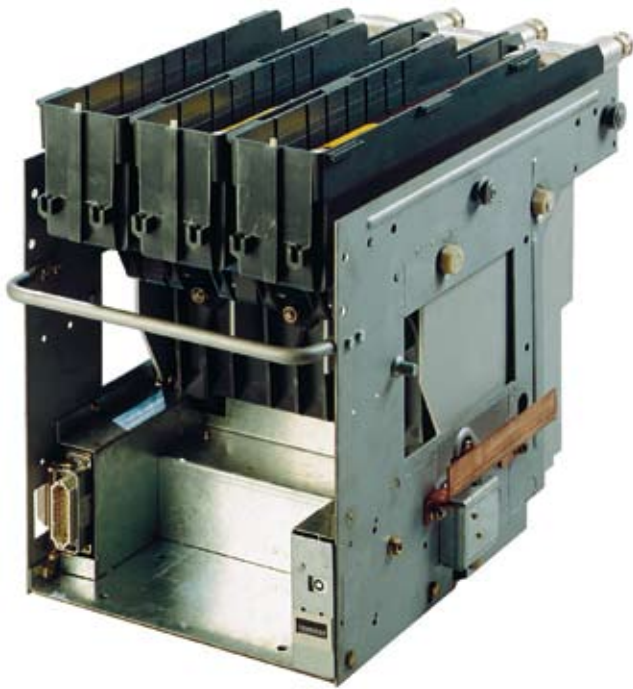

Contactors

UniMotor switchboards can be equipped with withdrawable V-Contact contactors.

The contactors are suitable for alternate current lines with a high number of operations. They are made of a resin monobloc, which houses the vacuum interrupters, the kinetic device, the control electromagnetic device, the multivoltage control feeder and the auxiliary accessories. The fuseholder is mounted on the monobloc.

The closing of the main contacts is carried out by the electromagnet whereas the opening is tripped by an opposing spring. A sturdy and compact construction ensures a very long electrical and mechanical life even without maintenance.

A versatile range of accessories offers tailor-made applications and easy stocking.

The accessories can be promptly installed or replaced as the auxiliary circuits are mounted on an easily removable frame.

Interruption principle

The main contacts operate inside the vacuum interrupters (the vacuum level is 13×10^{-5} Pa). When a contactor interrupter is opened, the fixed and moving contacts rapidly separate. The overheating resulting from the contacts separation generates metallic vapors which keeps up the arc until it reaches the first zero current passage. Afterwards, the cooling of the metallic vapors restores the dielectric rigidity on the zero current passage, thus making high recovery voltage values sustainable. In the motor switching version, the chopped current value is lower than 0.5 A with extremely limited overvoltages.

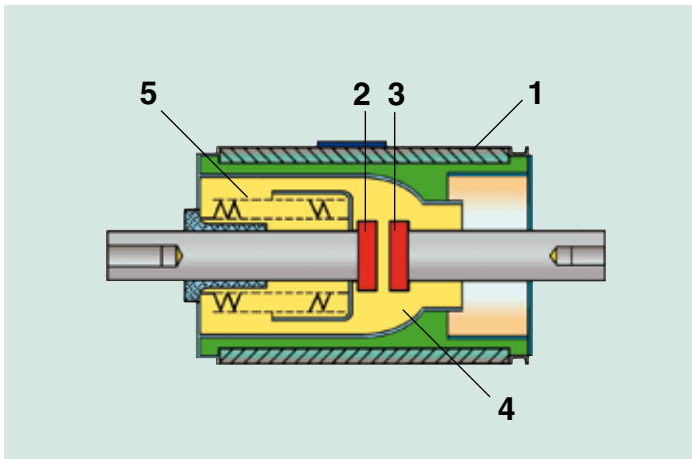

Cross-section of the vacuum interrupter

- 1 Ceramic housing
- 2 Moving contact
- 3 Fixed contact
- 4 Metallic screen
- 5 Bellows.

Contacteur fuses

Fuses suitable for motor starting and transformers are used to protect short-circuit power circuits up to 1000 MVA.

They are housed in the contactor along with the interrupters and placed on proper supports.

When energized, the fuses automatically open the contactor. The contactor can be fitted with fuses in compliance with DIN and BS Standards.

The fuses should be chosen according to the final application.

Voltage transformer

A single-phase voltage transformer complete with protection fuses can be mounted in the withdrawable truck. The voltage transformer is to be used solely for the supply of the operating mechanism coils on the contactor.



Fuses in compliance with DIN.



Fuses in compliance with BS.

Electrical characteristics		V7 Contactor				V12 Contactor
Rated and insulation voltage	kV	7.2				12
Withstand voltage at 50Hz	kV	20				28
Impulse withstand voltage	kVp	60				60 ⁽¹⁾
Rated frequency	Hz	50-60				50-60
Rated service current	A	400 (cat. AC4)				400 (cat. AC4)
Rated service current	A	6000 / 2500				6000 / 2500
Maximum rated overcurrent for ½ period (peak value)	A	55000				55000
Rated breaking capacity	A	4000				4000
Making capacity	A	4000				4000
– opening operations	No.	25				25
– closing operations	No.	100				100
Ultimate performances						
• 900 hourly operations	kV	2.2/2.5	3.3	3.6/5	6.2/7.2	11/12
– motors	kW	1000	1500	1500	3000	5000
– transformers	kVA	1100	1600	2000	4000	5000
– capacitor banks	kVAR	1000	1500	1500	3000	4800
• 300 hourly operations (capacitor banks, back to back)	kV	3.6	7.2			12
– rated current	A	250	250			230
– peak value	kA	8	8			8
Opening time/Closing time	ms	15 ... 20 / 60 ... 80				15 ... 20 / 60 ... 80
Electrical and mechanical life (opening/closing cycles)	No.	1,000,000				1,000,000

(1) 75kVp until the metal shutter is closed with the contactor truck isolated.

MAIN COMPONENTS



UniMotor enclosure.



Earthing switch.



Contactor truck drive mechanism.

UniMotor enclosure

The UniMotor enclosure is the contactor compartment and it is designed to house the vacuum contactor and the different power apparatus (fuses, measurement transformers, earthing switch).

• Contactor positions

Contactor position inside the enclosure:

Connected: main and auxiliary circuits connected

Isolated: main circuit disconnected, auxiliary circuits connected (test position) or auxiliary circuits disconnected (drawn-out position)

Withdrawn: main and auxiliary circuits disconnected. The contactor is partially or fully withdrawn from the enclosure.

Both in the connected and in the isolated positions, the contactor is situated behind the closed door.

To switch from test to drawn out position, it is necessary to disconnect the auxiliary circuit connector.

Fuses can be replaced in the test position.

• Enclosure and contactor locks

To guarantee safe operating conditions, the apparatus is equipped with:

- Mechanical lock to prevent the contactor racking-in and out when closed
- Mechanical lock to prevent the opening of the enclosure door when the contactor is closed
- Mechanical device for the automatic closing of the earthing switch, after the racking out of the contactor
- Mechanical device for the automatic opening of the earthing switch, before the racking in of the contactor
- Mechanical lock to prevent the earthing switch opening and the racking-in of the contactor when the door is open
- Electrical lock to prevent the closing of the contactor between the connected and isolated position
- Electrical lock to prevent the electrical local closing of the connected contactor
- Electrical lock to prevent the electrical remote closing of the isolated contactor.

- **Current transformers**

The apparatus can be equipped with three-phase current transformers integrated in the same compact cast resin monobloc. The monobloc, always tripolar, is complete with cable terminals and suitable for two/three phases primary or secondary circuits. This type of monobloc is to be chosen according both to the primary current and to the number of phases and secondary windings. Current transformers are available in the following configurations:

- with three active phases and a single core for each phase;
- with three active phases and two cores for each phase;

- with two active phases and a single core for each phase;
- with two active phases and two cores for each phase.

- **Earthing switch**

On request, each enclosure can be equipped with an earthing switch mounted on the cable side with a 12.5 kA short-time withstand current (peak value).

The earthing switch control automatically trips each time the contactor is in the isolated and connected position and the enclosure door is opened. This configuration guarantees the proper cable earthing and prevents any possible misuse.

Characteristics of the three phase current transformers

Active phases	3 max
Cores per phase	2 max
First core performances (measurement)	15VA/1
Second core performances (protection)	10VA/5P10
Rated primary current (I_{pn})	30 - 300 A
Rated secondary current (I_{sn})	1A (TA 1 core); 5A (TA 2 cores)
Rated thermal short-circuit current (I_{ter})	80 x I_{pn}
Rated dynamic short-circuit current (I_{din})	350 x I_{pn}
Maximum permanent heating current	= I_{pn}
Insulation voltage	12 kV
Rated frequency	50/60 Hz

MAIN COMPONENTS



Branch connectors.

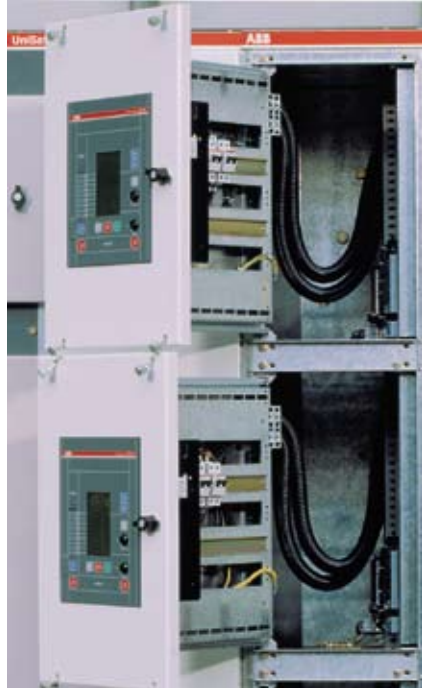

Unit for auxiliary equipment.

Main busbars

The main busbar can be either flat or tube galvanized copper fixed to isolators. Both the busbar and the isolators are suitable sized to withstand thermal and electrodynamic stresses. The main busbars run through different compartments without any diaphragm so as to form an uninterrupted duct. The main busbars can withstand the following rated currents:

- 2500 A when coupled with UniSafe switchboards;
- 4000 A when coupled with UniVer G switchboards due to short-circuit currents.

Their sections are suitable for 800 A - 1250 A rated currents.

Branch connectors

The connectors link the main busbars to the contactor supply contacts and are sized and fixed to withstand the thermal and electrodynamic stresses due to short-circuit currents.

Their sections are suitable for 800 A - 1250 A rated currents.

Busbar coatings

On request, both the main busbars and the connectors can be covered with an epoxy, self-extinguishing resin coating. Once the busbars are coated, all the joints are protected with insulating resin housings.

Earthing

Structure. All the structural metallic elements are solidly fixed together by means of screws designed to guarantee a safe connection of the apparatus different components.

Doors. The doors are connected to the main structure by means of a properly sized copper braid.

Contactor truck. The truck earthing is ensured in the connected and isolated positions, as well as in the whole isolating run by means of a jaw contact sliding on a copper conductor directly connected to the main earthing busbar.

Earthing busbar. The earthing busbar is made of electrolytic copper with a 400 mm² cross section. It runs through the whole switchboard length.

Terminals

The cable terminals are located on the lower monobloc. The feeder compartment can house up to two single-core or three-core cables per phase.

Auxiliary equipment

The REF 542 unit is installed on the door of the instrument compartment, which can house also auxiliary relays, modular switches, fuses and terminal boards.

Accessories

Standard completion accessories

- Side panels for covering the switchboard ends
- Expansion bolts for anchoring the switchboard to the floor
- Key locks
- Segregation partitions for closing the auxiliary cable passages
- Drawings and diagrams
- Instruction for the switchboard installation, service and maintenance.

Optional auxiliary accessories

- Support shelf for levers and handles
- Lifting hooks or eyebolts (1)
- Section irons and anchoring blocks
- Support for the main busbars positioning (1)
- Partitions for closing the medium voltage cable passages
- Truck for the contactor racking out (1)
- Extension for testing the contactor racking out (1)
- Insulating rod with earthing socket and cable (1).

Contactors optional accessories

- Voltage transformer and protection fuses
- Protection fuses
- Electric operation counter
- Mechanical interlock between two superimposed trucks (available only for electrical latching contactors).

Enclosure optional accessories

- Two or three-phase current transformer
- Earthing switch with making capacity and electrical signaling
- Key lock on the racking in and out operating devices (2)
- Mechanical interlock between two superimposed enclosures (available only for electrical latching contactors)
- Door key lock (2)
- Auxiliary contacts on the connected and isolated positions
- Auxiliary contacts (1 or 2) for signaling a missing or tripped fuse.



Door earthing system.

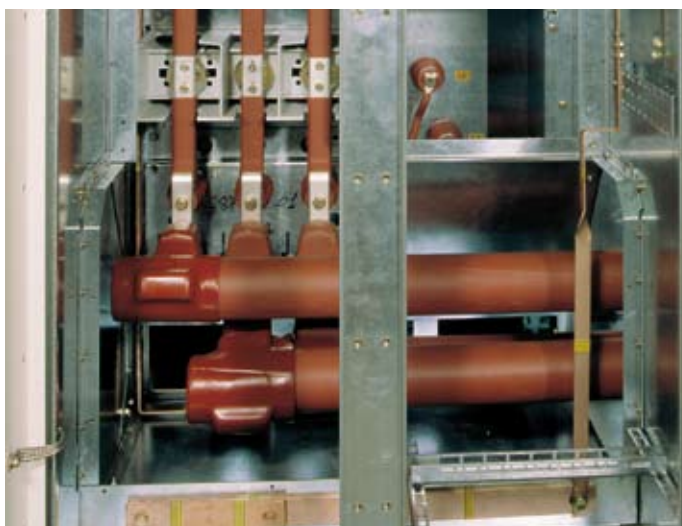

Main busbar system.

- (1) Quantity on request.
- (2) Same or different keys for different enclosures.

MAIN COMPONENTS

Typical diagrams of UniMotor Switchboards and contactors

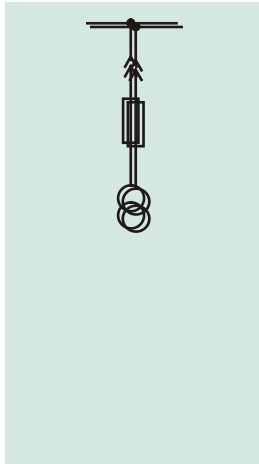

Measurement unit.

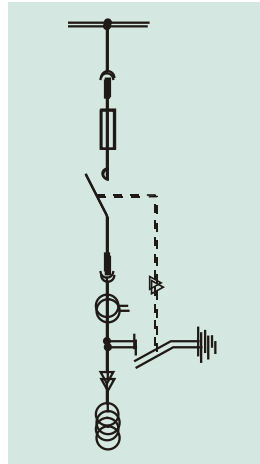

Transformer feeder.

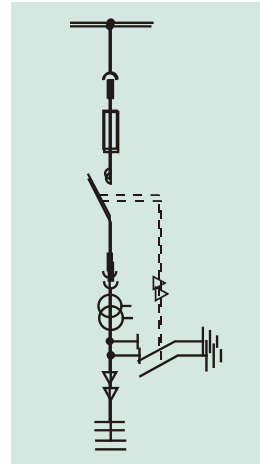

Capacitor bank feeder.

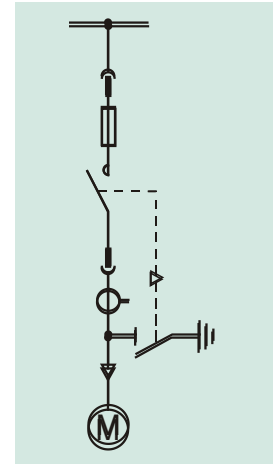

Across the line motor starting.

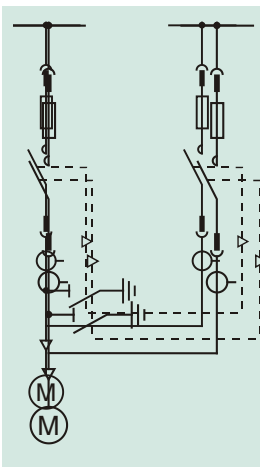

Reverse operation.

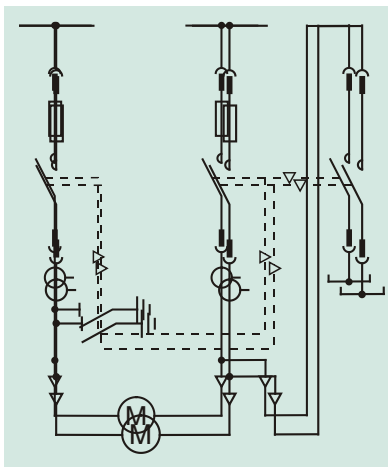

Star-delta motor starting.

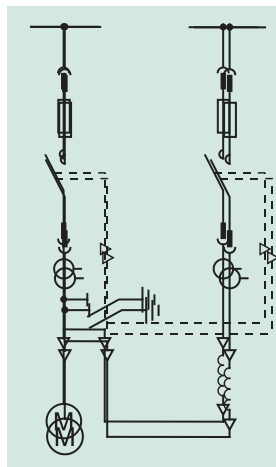

Reactor motor starting.

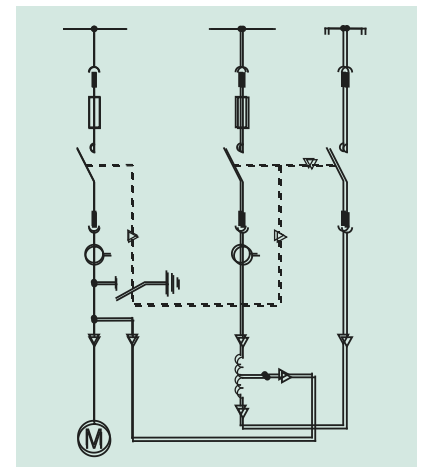

Auto-transformer motor starting.

SPECIFIC PRODUCT CHARACTERISTICS

Auxiliary circuit wiring	22
Surface protection	22
Metal structure protection	22
Acceptance tests	23
Standard documentation	23
Weights	24

SPECIFIC PRODUCT CHARACTERISTICS

Auxiliary circuits wiring

- **Conductors:** the apparatus is fitted with black or white fire retardant conductors (testing procedures in compliance with IEC 332-3, Standards) whose cross-section is 1,5 mm² for power, control, signaling and voltmetric circuits, or 2,5 mm² for amperometric circuits. Where possible, the conductor terminals are made of crimped “faston” terminals.
- **Conductor identification:** the “conductor identification depending on the adjacent terminal” system (IEC 391 Standards, par. 3.4.1.A.1, par. 5.1.2 for examples) is used when detecting the conductors. According to this procedure, the symbol reproduced on the conductor end is the same as the symbol placed on the terminal and components connected to the conductor.
- **Electrical component identification:** each electrical component is identified by means of an adhesive indelible label showing the component electrical and topographic name.
The topographic name consists of two letters: the first shows the component position in the compartment, the second is a progressive letter. The topographic name allows a prompt positioning of the component and an easy definition of the conductor length.
The electrical name complies with the IEC 750 Standards for circuit wiring diagrams.

Surface protection

The UniMotor switchboards undergo different treatments depending on the following conditions:

- Installation** – indoor
- Climate** – temperate
– tropical
- Ambient** – normal
– corrosive (marine, industrial etc.)
– dry
– humid.

Metal structure protection

A standard treatment cycle is carried out for painting metal components such as coverings, doors, side panels etc.:

- degreasing
- pickling
- phosphating
- passivation
- drying
- oven painting with polymerized epoxy powder.

The surface finish is demi-mat embossed.
The painting minimum thickness is 50 micron.
The painted surfaces have successfully passed the adhesion tests in compliance with the DIN 53.151 Standards.



Acceptance tests

The acceptance tests carried out in our Test Laboratory include:

- industrial frequency voltage test for main circuits
- auxiliary circuit voltage tests
- mechanical operation tests
- auxiliary devices test
- wiring inspection.

Standard documentation

- For approval, two copies of the following drawings:
 - switchboard front
 - foundations
 - single-line diagram
 - electrical circuit diagram
 - apparatus list.
- As final documentation:
 - three copies of the final drawings plus a reproducible copy of the above documents
 - three copies of the switchboard and contactor instruction and maintenance booklets
 - quality assurance plan (on request).

SPECIFIC PRODUCT CHARACTERISTICS

Weights

Withdrawable contactor complete with current transformer and three fuses	70 kg
Enclosure with current transformers	120 kg
Unit equipped with three enclosures, three contactors, busbars and auxiliary equipment	1600 kg

INSTALLATION

Overall dimensions	26
Foundations	27
Fixing systems	28
Installation room	28

INSTALLATION

Overall dimensions

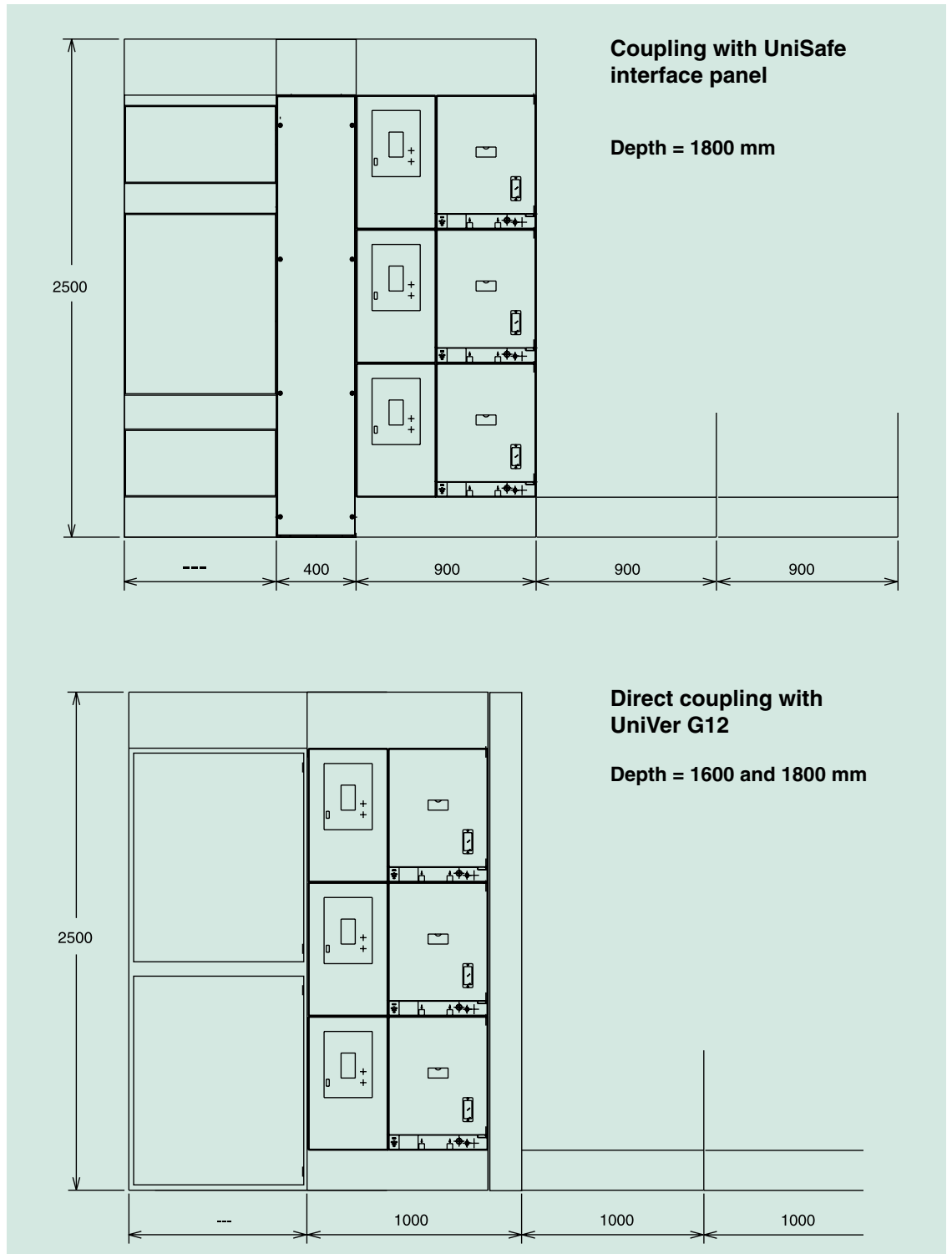

Foundations

Both the medium voltage cables and the auxiliary circuits are normally bottom entry. The switchboard can be fixed to the floor or placed on special base irons (on request).

- For direct fixing to the floor, expansion anchors are fitted into the relevant holes.
- For the fixing to the base irons, special blocks with bolts are provided. The base irons must be fixed and embedded in the surface casting.

Foundation drawings and fixing instructions are promptly sent to the customer shortly after the order confirmation so as to suitably equip the site before the switchboard is delivered.

As an example, the figure below shows a possible base irons fixing configuration.

UniSafe-UniMotor coupling

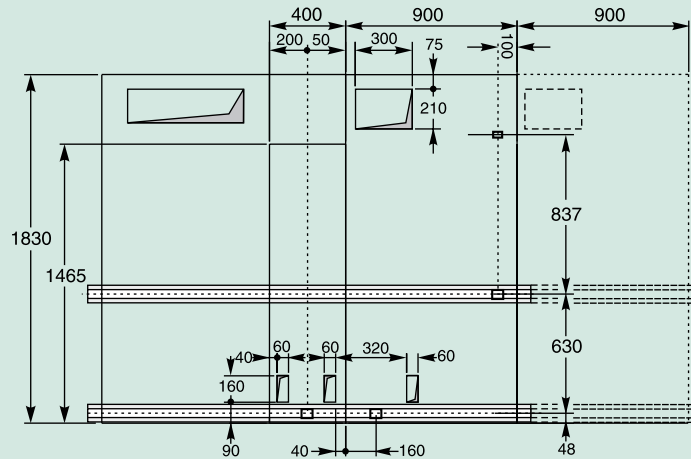

UniVer G12-UniMotor coupling

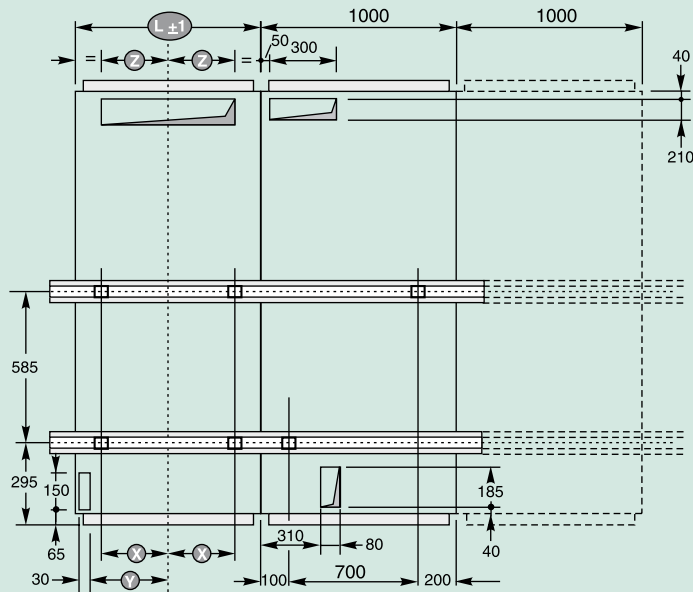

INSTALLATION

Fixing systems

- 1 Expansion anchoring bolt.
- 2 Plate.
- 3 Base iron (steel profile).
- 4 Fixing block.

N.B. The hole, screw and dowel dimensions are indicated in the foundation project documents.

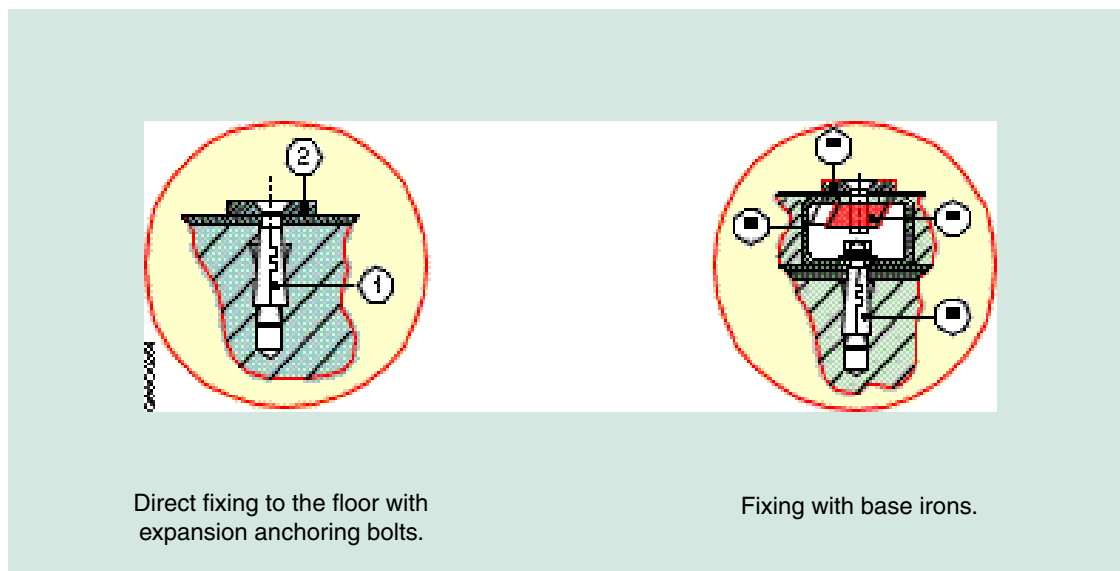

Direct fixing to the floor with expansion anchoring bolts.

Fixing with base irons.

Installation room

The installation room must be equipped according to the switchboard type and size. The observance of the given dimensions guarantees the proper apparatus functionality.

A [mm]	≥ 3000
B [mm]	≥ 50
C [mm]	≥ 1000
D [mm]	≥ 1500

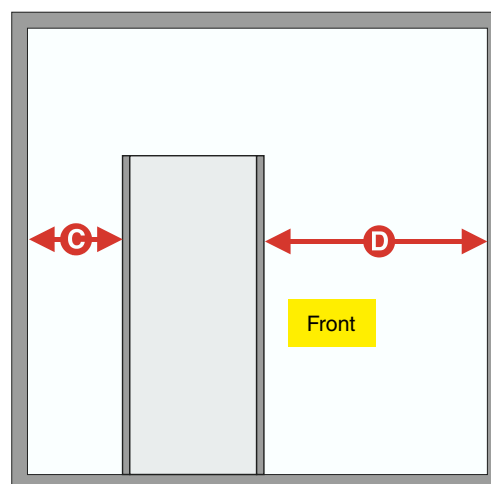
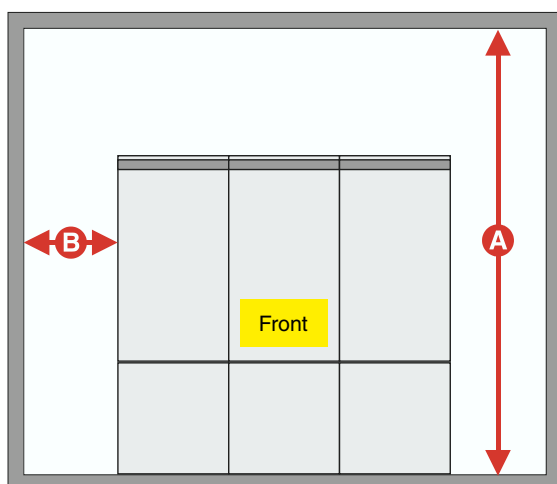

Contact us

ABB S.p.A.

Power Products Division Unità Operativa Sace-MV

Via Friuli, 4

I-24044 Dalmine

Tel.: +39 035 6952 111

Fax: +39 035 6952 874

e-mail: sacetms.tipm@it.abb.com

ABB AG

Calor Emag Medium Voltage Products

Oberhausener Strasse 33 Petzower Strasse 8

D-40472 Ratingen D-14542 Glindow

Phone: +49(0)2102/12-1230, Fax: +49(0)2102/12-1916

E-mail: calor.info@de.abb.com

www.abb.com

The data and illustrations are not binding. We reserve the right to make changes without notice in the course of technical development of the product.

Copyright 2009 ABB.
All rights reserved.