



ABB Review

The corporate technical journal
of the ABB Group

www.abb.com/abbrevreview

4 / 2007

World of innovation

Innovation highlights of 2007
page 6

Five-level frequency converters
page 26

Substation automation takes a higher gear
page 38



ABB

A central image of a globe of Earth, showing continents and oceans, is surrounded by several pieces of cracked, light brown eggshell. The eggshell pieces are arranged in a circular pattern around the globe, with some pieces overlapping. The background is a dark, starry space. The globe is slightly tilted, and the eggshell pieces are scattered around it, creating a sense of breaking through a barrier.

According to a popular story, Christopher Columbus made an egg stand on its end by tapping it gently on the table. This tale is often used to illustrate how effective solutions can remain elusive until approached from a fresh angle.

This “thinking outside the box” (or eggshell?) is the essence of innovation. In this end-of-year edition, *ABB Review* presents a selection of the successes that the company’s research labs have hatched this year. Welcome to the *World of Innovation!*



Obligated to the tradition of innovation

Successful technology innovation is based on three fundamental capabilities: to know what customers want, to provide the cutting-edge technology to satisfy their needs, and together with them develop ideas for future applications.

Driving innovation along these three lines is a century-old tradition at ABB, as old as the company itself. ABB has a history of ingenious inventors pushing technology forward, beginning with the development of generators 100 years ago, distribution and transmission with high voltage DC and drives technology in the 1950s, and control and automation technologies in line with the computer boom since the seventies.

Because significant inventive steps involve cross-fertilization between areas that have no obvious link, ABB's broad technology base in energy and automation is a perfect breeding ground for fostering a plenitude of innovation. Our seven research programs cover the whole technology spectrum of the company, and the technologies developed within that frame are used throughout all divisions.

In this issue of *ABB Review* we invite you to learn about innovative steps taken in 2007. The examples we have chosen are representative of many more in all our business applications.

The consequent application of information and communication technologies in a traditional area of hardware components, such as circuit breakers and transformers and other equipment in a substation, is a prominent example of merging know-how from very different technical disciplines. With our innovative tools for design, engineering and testing, we have brought a new class of higher service and engineering performance to substations based on the IEC 61850 standard. Customers benefit from faster delivery and higher operational flexibility as well the greater ease of interoperability.

We applied the know-how of heat transfer with heat pipes to the generator circuit breaker – the breaker type holding the world record in breaking capacity – and extended its application range by 20 percent, an impressive step in a technological field generally considered mature.

Spillover effects between industries are also drivers of innovation. With the application of multi-variable model predictive control – which is well established in the petrochemical industry – to utility power plants, we made great strides in increasing efficiency and reducing emissions.

Transmission of electrical power with direct current is a technology whose ability to meet global challenges is increasingly being recognized. Energy savings on long transmission lines is a burning issue in China and other countries with high energy needs and long distances between the power generation sites and the large consuming urban centers. Ultra voltage levels of 800 kV DC are now available to transport several gigawatts of power.

Remote service is another field of innovation with high customer satisfaction. Here the effective application of information and communication technologies is instrumental and we are proud to have pioneered major steps for remote service in almost all of our business applications.

While even three-year-old children are agile enough to put puzzle pieces together, robots, known to us as robust and powerful machines, have had difficulties with such tasks for a long time. Now, with the help of force control, they can operate with the precision of a watchmaker and even develop a “feeling” for delicate fine-motoric movement. This force control opens up many new applications for robots throughout the whole industry, with significant cost savings and product quality enhancement for customers.

Our continuous stream of innovations is the outcome of thousands of inventive engineers and researchers working in ABB's development and research teams around the world. These innovators assess customers' problems and needs, and, as part of a global team, apply their multi-disciplined talents to the creation of solutions, helping customers to see new opportunities in their own innovation processes.

These strong innovation dynamics are a traditional strength at ABB. It is also a tradition of *ABB Review* to present the innovations we are especially proud of in the year-end issue. We hope you feel the pioneering spirit that moved the people behind these innovations and become inspired yourself.

Enjoy your reading.

Peter Terwiesch
Chief Technology Officer
ABB Ltd.

ABB Review 4/2007

World of innovation

Innovation highlights

6

A successful 2007

ABB Review highlights eleven great innovations of the year.

Product innovations

12

Signaling enhancements

Is there more to data than meets the eye? Enhanced instruments learn to read between the lines of a measurement.

18

Performing at a higher level

Breaking from a pipe-dream to reality: heat-pipe cooling enhances the capacity of circuit breakers.

22

A touching movement

Robots may be good at heavy and repetitive work, but when it comes to that special finishing touch, there's still nothing like – a robot.

26

A higher level of efficiency

What goes up when things get more level? Energy efficiency gets a boost as inverters shift to five-level technology.

32

Integration breakthrough

Meet the DC breaker that integrates advanced control – and discover why it's time to give wiring a break.

Process innovations

38

Speed and quality

Getting the most out of the IEC 61850 standard – ABB crafts a powerful substation automation engineering tool.

42

Wellness for your profit line

Just think of all the failures that won't happen because ABB is monitoring the heartbeat of your plant.

45

On-site transformation

When a transformer needs repairs, it need no longer return to the factory. TrafoSiteRepair™ brings the factory to the transformer.

49

Integration guaranteed

The lack of a common platform for Process Analytical Technology is a bitter pill for the pharmaceutical industry. ABB is providing a sweeter medicine.

53

Efficiency up, emissions down

Learn why more variables mean less variation, and how that can enhance plant profitability.



6

www.abb.com/abbreview

R&D focus

58

Green ships on the high seas

Tailor-made power turbines with turbocharger technology are cutting costs, fuel and emissions.

62

The strongest link

How ABB is foiling blackouts in aluminum-smelting plants.

66

More muscle, less waste

Fit not fat – ABB's workout program ensures a plant isn't wasting that valuable asset, energy.

70

Wireless detection

No wires attached – meet the motion detector that was designed for comfort.



18



53

Perpetual pioneering

74

100 years

From one steam boiler to a billion-dollar business: ABB celebrates a century of presence in China.



74

A successful 2007

In labs across the world, ABB's scientists and engineers are hard at work seeking ways to create new products, make existing products better, or find novel applications for proven products. In brief, they are upholding ABB's tradition of pioneering and innovation and laying the foundations for the success stories of tomorrow.

This article takes a quick tour of a small selection of ABB's achievements in innovation of the past year. These are also discussed at greater length in this (or recent) editions of *ABB Review*.

Signal processing gives instrumentation a boost

The integrity and reliability of instrumentation is indispensable for the efficient operation of a process plant. At the same time, such equipment must be easy to install and low on maintenance. ABB presents a flowmeter that auto-calibrates, a pressure transmitter that knows when it's plugged and wireless standards for device communication.

The circuitry of the WaterMaster range of flowmeter products has been redesigned. It now includes an integrated auto-calibration function, which not only reduces the necessity for human supervision, but also assures continuous accuracy. Because the number of precision components having a bearing on measurement accuracy was reduced from about ten to a single resistor, the overall dynamic behavior of the device in the face of temperature changes has become much easier to handle.

ABB has used an innovation of a different kind to improve a differential



pressure meter. As the meter's measurement lines can easily get plugged (blocked), frequent inspections are necessary as such occurrences cannot easily be detected from the control room – until now. ABB's solution lies in observing the process noise – or rapid parameter fluctuations that are normally of no interest to the measurement. ABB now uses an automatic analysis of this noise to check for plugged lines.

Instrumentation traditionally needs a lot of wiring. This not only inflates implementation costs, but is also a potential source of error and limits flexibility when changes are required. This is why interest in wireless communication in instrumentation is on the rise. Just as wired fieldbus stan-

dards currently allow devices from different manufacturers to be combined, a wireless standard will soon allow the same to be achieved with wireless products. ABB is working with other leading instrumentation manufacturers on the implementation of two emerging standards: HART 7 and ISA SP100.

For more information and background on these innovations in instrumentation, see "Signaling enhancements" on page 12 of this edition of *ABB Review*.

New tool advances substation automation

The IEC 61850 standard for substation automation was a major advancement in electrical power technology, enabling application of state-of-the-art information and communication technology. And now, engineers can take full advantage of the technology with ABB's new substation engineering environment.

In this new environment, the devices in a substation are able to communicate and provide a broad set of data to describe and control the substation operation. Engineers master the enor-



mous amount of data throughout the complete design phase of the substation. The automation system and individual functionality can be thoroughly tested before on-site operation begins.

ABB's new tool speeds up engineering and testing processes, resulting in faster-than-ever delivery of pretested substations. With its increased reliability and its plug-and-operate capability, the system short-cuts extensive commissioning phases. Outage times are reduced through the manifold possibilities of testing within the virtual engineering environment, providing seamless operation when rebuilding or maintenance is required.

For more information on ABB's new substation engineering environment, see "Speed and quality" on page 38 of this issue.

Silent cooling

Advanced heat pipe cooling answers the demand for lighter and more robust circuit breakers, but more importantly, performance is increased by over 25 percent!

Large circuit breaker nominal currents generate a tremendous amount of heat, which must be limited if other

system components are to remain within their rated temperature tolerances. Because natural cooling limits the rated nominal current, many of today's generator circuit breakers (GCBs) employ forced cooling methods – also a source of extra heat – to increase nominal current levels. However, these also limit nominal current capability.

To further increase this current while meeting the ever-increasing market demands for lighter, robust and more powerful products, ABB has developed an innovative cooling method based on the heat-pipe cooling concept. The ABB system is composed of three major components: an evaporator section attached to the GCB conductor (which is effectively the heat source); a transfer section; and a condenser section (or heat-sink) located in the cooler environment outside the enclosure. This solution needs no electricity to operate, requires little maintenance and is impressively silent. Its main benefit, however, is the extension of generator breaker nominal current from 18,000 to 23,000 A.

A more detailed article, "Performing at a higher level," can be found on page 18 of this edition of *ABB Review*.



Turning machining robots into universal tools

Based on ABB's pioneering applications of robots for the delicate assembly of fine structured parts, ABB has now taken a new step towards achieving watchmaker precision in robot motion. The innovative approach – Flex Finishing – can reduce overall programming times by up to 80 percent for robots used to grind castings, vastly improving productivity.



This new, unique robot application combines several innovative elements by using the latest ABB robot controller, IRC5, with its high speed sensor interface, feedback loops to control pressure and speed of the grinding tool, and a programming environment that allows the robot to find the optimum path by itself.

Robots equipped with this ability to learn how to touch and handle work pieces reduce the cycle time of the operation by some 20 percent – and with this better motion control the lifetime of the grinding tools can be extended by 20 percent as well.

Product finishing operations in foundries are now much simpler, enabling finished castings to be produced with a higher quality, faster and at lower cost.

For more information see "A touching movement" on page 22 of this edition of *ABB Review*.

Frequency converters poised to deliver great energy savings

ABB's five-level frequency converters enable significant energy savings by lowering the barrier to the adoption of power-electronics in motor control.

Motors consume about 30 percent of all electrical energy generated in the world. This means that any efficiency improvement in this sector is of huge benefit to the planet's dwindling energy reserves and fragile environment. About three quarters of motors are in variable-speed applications, an area where traditional control methods cause a huge waste of energy.

Frequency converters can change all this. In fact, they are the most efficient method available for such control tasks and adopting them can reduce losses to a fraction of their former value. The worldwide application of frequency converters in medium voltage applications alone has the

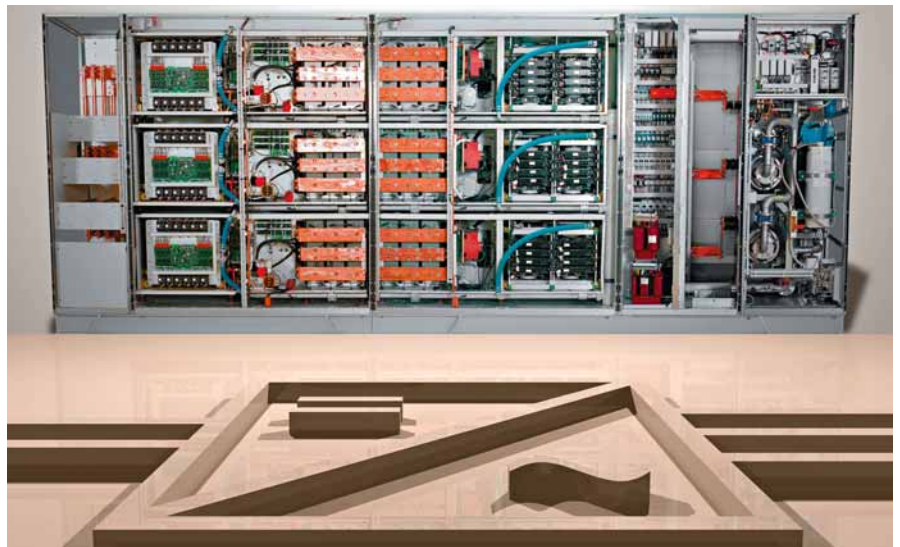

potential to replace the equivalent output of 144 fossil fuel plants. However, the technology is not universally applicable because such converters produce "harmonics" – or plainly put, the waveform of their output voltage is far from ideal. This can lead to a torque ripple in the drive-chain, heating in the motor and cause electrical interference in other equipment. Also, in medium-voltage applications, it is difficult to obtain the required voltage levels with traditional two- and three-level topologies.

In order to make converters more acceptable, ABB is seeking ways of reducing harmonics and increasing the output voltage. ABB's new five-level converters answer both needs: It produces considerably less harmonics than its two- and three-level predecessors, while at the same time permitting higher voltages to be attained. The technology is now implemented in the company's ACS 5000 drive units.

For the story behind ABB's five-level converters, see "A higher level of efficiency" on page 26 of this issue of *ABB Review*.

Breaking new ground: ABB's flexible and compact DC breaker

When it comes to installing equipment, there are two assets that are perpetually in short supply: time and space. Equipment requiring complex wiring costs much time to install, and the auxiliary equipment to which it must be wired occupies additional space. ABB SACE Emax DC breaker addresses both issues through its unprecedented levels of integrated functionality.

Until now, DC breaker applications could be divided into two categories: breakers that triggered automati-

cally and those that needed an external impulse. The automatic type was of relatively simple construction, and could provide only auto-triggering short-circuit protection. Where more sophisticated triggering was required, monitoring and control equipment had to be installed on an external switchboard.

Now what if this functionality were integrated in the breaker? This would not only greatly simplify installation but also economize on wiring, auxiliary power supplies and valuable space while also improving robustness and reliability. In the field of AC breakers, such integrated solutions have been available for some time. But in DC applications the concept is not as simple to implement because of the more challenging methods of measurement. ABB has come up with an innovative and unique solution. The SACE Emax DC is the only breaker of its type on the market: It offers a wide range of



protection functions, all sensors are fully integrated, and despite being almost a mechatronic system in itself, the breaker can work without an auxiliary power supply.

For more background information, see "Integration breakthrough" on page 32 of this edition of *ABB Review*.

Ultra-high voltages for ultra-low losses

The energy market is changing rapidly: Interconnections and trading are creating new challenges, as are developments such as the growth of wind power in areas where infrastructure is weak. The rapidly rising demand in countries such as China is leading to huge investments in transmission infrastructure. ABB is at the forefront of the development of technologies to meet these challenges.

When bulk electric power must be moved over large distances, it is most efficiently accomplished using high voltages. The higher the transmission voltage, the lower the conduction losses and hence the more power the line can carry. ABB offers both high-voltage AC (HVAC) and high-voltage DC (HVDC) solutions for power transmission. ABB has devel-

oped equipment for 800 kV HVDC and 1000 kV HVAC (The previous highest commercially used voltages were 600 and 800 kV).

HVDC is highly controllable and can, for example, be used to "inject" power into an area where shortfalls in generation are threatening to cause blackouts. The mode is also immune to the stability issues that limit the capacity of very long AC lines. As the mode is inherently more reconcilable to space-saving coaxial cables than HVAC is, it is frequently used on submarine links

and in other situations where the cable must be buried.

However, the sophisticated converters needed to feed power into and out of HVDC lines mean the technology is best suited for point-to-point links. Where it is necessary to tap power at an intermediate point or even create an entire network, HVAC has a clear practical advantage. The most effective solution for the transmission of bulk power over a long distance is often a mix of both applications: an HVDC line with HVAC feeders.



For more information on ABB's activities in ultra-high voltage transmission, please see **Asplund, G.**, "Ultra high voltage transmission," *ABB Review* 2/2007, 22-27.

Remote service: a new dimension of customer care

Remote service technologies support field engineers, irrespective of location, in ways only dreamed of five years ago. These technologies, combining real-time monitoring of product and system performance and automatic alerting of service engineers have now been extended to larger parts of ABB's product spectrum.

Using advanced embedded intelligence in the products and secure communication channels across customer firewalls, ABB is permitting remote monitoring of the condition of analyzing equipment. Signals received at service centers are automatically



monitored and analyzed using the accumulated knowledge of hundreds of man-years of experience now held in extensive performance databases. By comparing the performance of individual devices with historic data from countless similar devices in the field, the knowledge-based systems support ABB's engineers in proposing the best suitable strategies for mainte-

nance or repair. A faster decision process and subsequent tailor-made service cuts cost and reduces downtime of customer installations.

For more information see "Wellness for your profit line" on page 42 of this edition of *ABB Review*.

TrafoSiteRepair™ – a byword for speed

TrafoSiteRepair™ is an innovative solution created by innovative people to improve power transformer availability.

Repairing, refurbishing or retrofitting power transformers on-site has long been accepted as the best method of getting units back into service in the shortest possible time. However, until recently major repairs, such as repairing or replacing the windings, meant the transformer had to be transported to a factory where the required space and equipment are available, and this was very costly in terms of time. ABB's TrafoSiteRepair™ changes all this by allowing major repairs to

be performed on-site. This in turn minimizes the outage time of the transformer, the unavailability of the power supply and more importantly, the loss of revenues.

TrafoSiteRepair™ is a combination of years of experience and state-of-the-art technology, and includes verified processes that are to the same standard as those used in a factory envi-

ronment. Some new innovations have contributed to its success, such as a Mobile High-Voltage Test System, which replaces the heavy and somewhat inflexible motor-generator set; an on-site Low Frequency Heating (LFH) drying system; and a Dielectric Frequency Response (DFR) test to determine the remaining moisture level in the cellulose insulation of a transformer. TrafoSiteRepair™ is

already credited with getting some 200 units in 25 countries back up and running in double quick time.

A more detailed article, "On-site transformation" can be found on page 45 of this edition of *ABB Review*.



Building bridges

ABB's Industrial IT for Process Analytical Technology (PAT) delivers real business benefits.

New drugs are the life blood of a pharmaceutical company. Even though it can take years to put a drug on the market at a cost in excess of \$800 million, the rewards more than

outweigh the investment. However, the balance is shifting somewhat because of two major factors: companies are investing more in R&D than ever before at a time when the actual number of New Chemical Entities being approved is in decline; and increasing production costs. These increasing costs have forced the industry to look at new and innovative ways of becoming more efficient, both in the creation of new drugs and the production of existing drugs.

Together with these innovations, an initiative known as Process Analytical Technology (PAT) has been making its presence felt since its launch in 2002. Its goal is to understand and better control the entire pharmaceutical manufacturing process. Analyzer technology is at the heart of the PAT initiative, but the availability of multiple analyzer platforms combined with the absence of some form of standard for exchanging data has resulted in "islands of PAT." ABB has been building bridges between these islands with its Industrial IT Process Analytical Technology. This is a true innovation that meets many of the key requirements of a truly integrated PAT solution.

A more detailed article, "Integration guaranteed" can be found on page 49 of this edition of *ABB Review*.

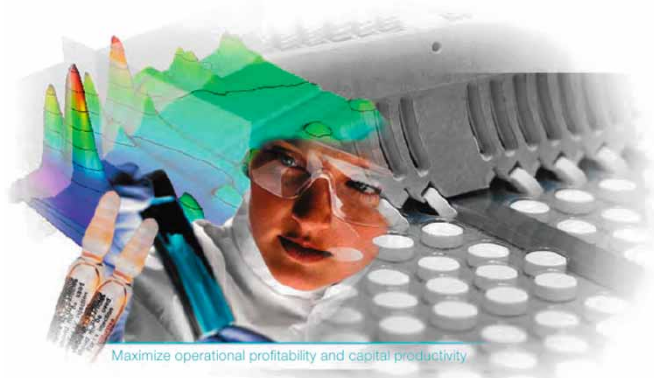

Maximize operational profitability and capital productivity

Predict & Control pumps up plant performance

Advanced process control technologies, while well established in many industries, have only recently been utilized for power plant control and optimization – and the results are remarkable.

Multi-variable model predictive control (MPC) boasts superior performance over traditional single-input/single-output (SISO) control strategies. By making full use of the increased power of computers, MPC-based solutions can be deployed in large utility power plants.

The main goal of advanced process control is to reduce process variations; for power plants, this translates to improved process stability and reliability, and reduced thermal cycle stress on



the high-pressure parts. Reduced variance allows the power generation process to operate closer to the given plant's optimum. Often, this optimum is defined by constraints. By minimizing variations, the process can move

closer to its limit without violating the constraint.

ABB's new product, Optimize^{IT} Predict & Control, answers the shortcomings of previous MPC solutions, such as limitations in the choice of control models and reliance on open loop step testing.

Plants that have implemented ABB's MPC have realized NOx reductions of eight to 40 percent, while generating tens of GWh per year of additional electrical energy with the same fuel consumption.

For more information on ABB's Predict & Control, see "Efficiency up, emissions down" on page 53 of this issue of *ABB Review*.

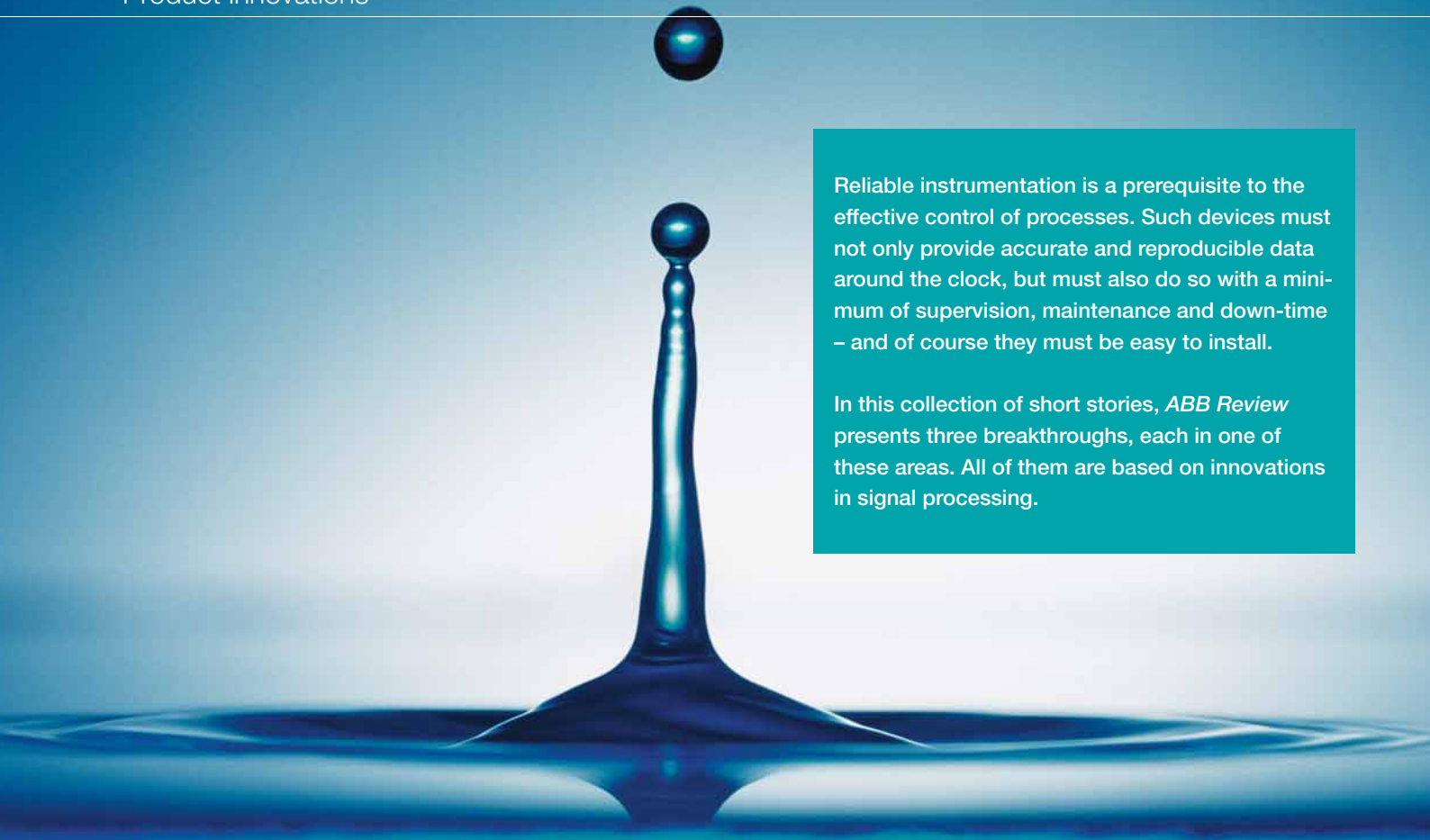

Reliable instrumentation is a prerequisite to the effective control of processes. Such devices must not only provide accurate and reproducible data around the clock, but must also do so with a minimum of supervision, maintenance and down-time – and of course they must be easy to install.

In this collection of short stories, *ABB Review* presents three breakthroughs, each in one of these areas. All of them are based on innovations in signal processing.

Signaling enhancements

Signal processing boosts instrumentation

Sean Keeping, Eugenio Volonterio, Ray Keech, Gareth Johnston, Andrea Andenna

Signal processing is not always the obvious starting point when developing a new instrumentation product: It is often more straightforward to seek breakthroughs in such fields as the efficiency and robustness of the packaging of sensors or electronics, refinements in the use of materials and processes, and improved usability.

However, as instrumentation products become increasingly commoditized, the one significant area of differentiation between vendors is the additional

value that can be obtained from the sensing system itself.

The process of defining this added value starts with knowledge. In creating a new product, it is vital to understand customer needs – and to recognize useful additional information that can be derived or inferred from measured data, providing valuable insights into the status or condition of the product or process.

ABB has invested in novel ways of using signal processing to boost the

customer value of its products. The fruits of these efforts are illustrated in the following by two case studies; the first measuring flow and the second measuring pressure.

The third case presented is a study into wireless technology. It demonstrates how this new technology can increase the availability of instrument features – meeting the needs of future applications.

Self-calibration for an electromagnetic flowmeter

ABB has introduced a new flowmeter that attains unprecedented levels of stability and performance thanks to an innovative self-calibration concept.

An electromagnetic flowmeter is made up of two key parts:

- The sensor, consisting of a flow measurement tube containing an insulated lining, energizing coils and two or more measurement electrodes **1**.
- A flow transmitter, such as the new ABB WaterMaster **2a** or ProcessMaster **2b**, which drives the coils and measures the very small AC signal from the measurement electrodes.

In order to fulfill the constantly evolving metrological requirements of instruments, in this case driven by the OIML¹⁾ International Recommendation R49 [1], ABB has developed a self-calibration concept [2]. This has been implemented in the company's WaterMaster range of flow products.

By fulfilling this recommendation, the product is able to conform to the Measuring Instruments Directive (which became a legal requirement in November 2006). OIML R49 requires that electromagnetic flowmeters have "checking facilities" – this means a simulated signal is applied to the input of the flow transmitter and it is verified that the output is within predefined limits.

This technique was then developed further by not only using this signal to

1 Sensor unit of an electromagnetic flowmeter

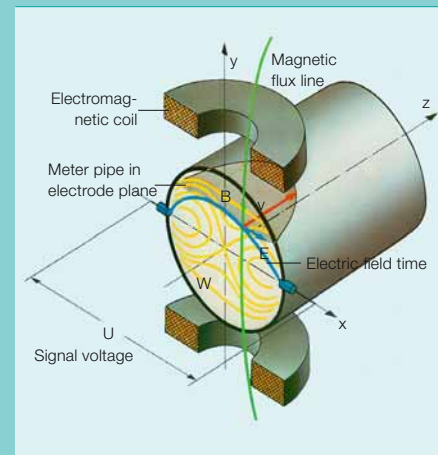

2 ABB's WaterMaster **a** and ProcessMaster **b** electromagnetic flow transmitters



Footnote

¹⁾ OIML: International Organization of Legal Metrology / Organisation Internationale de Métrologie Légale

3 Block diagram of ABB's novel auto-calibration for electromagnetic flowmeters

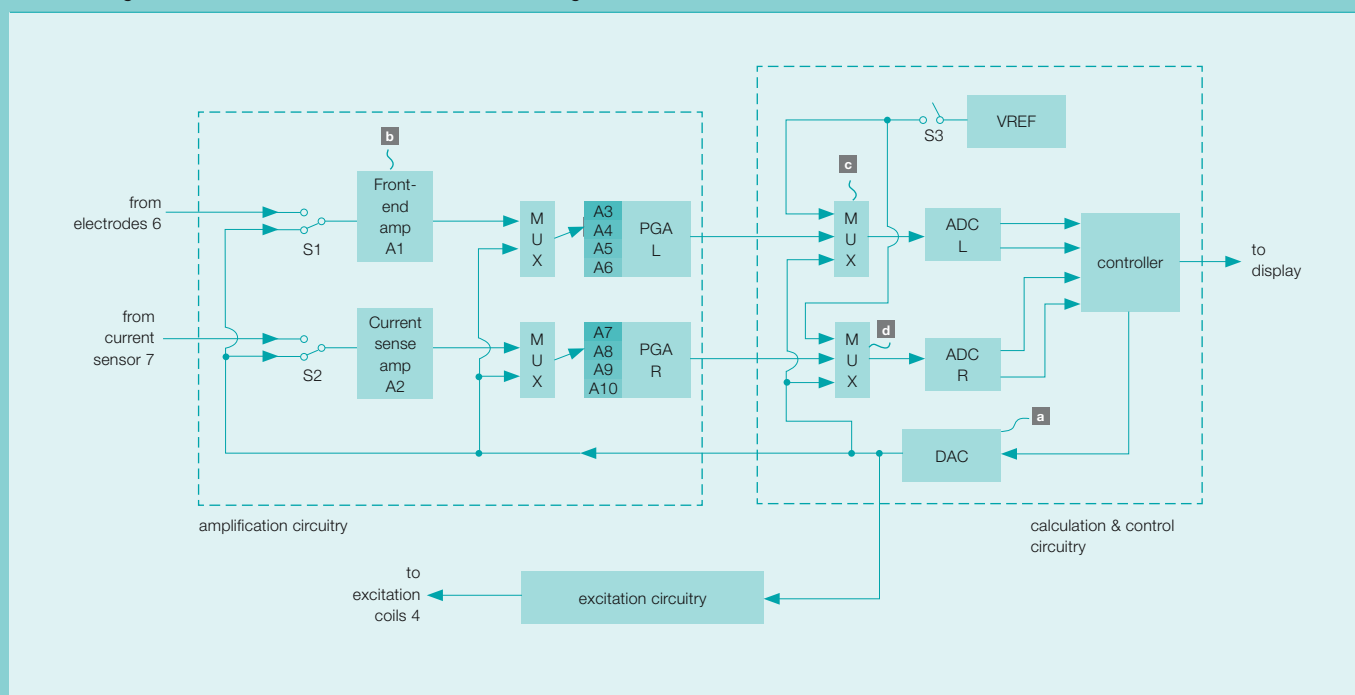

Product innovations

check the amplitude but also to perform automatic calibration. This not only meets and exceeds the OIML R49 requirements; it also means the instrument has multiple attractive features. These are listed in **Factbox 1**.

Operation of this new concept is illustrated in **3**. Since the system automatically adjusts itself, no precision parts are required in the measurement chain. An audio codec chip with high-linearity is used as analog to digital converter (ADC). Using an arrangement of multiplexers, the simulated signal is generated with the digital-analog con-

Factbox 1 Features of ABB's new Watermaster range of flowmeters

- Self-calibrating instrument
- Factory calibration no longer necessary
- Calibration adjustment is continuous during normal running
- Ultra-stable performance over time
- Very low temperature coefficient
- Low-cost audio codec
- Design immune to any dc offsets
- Lower cost with only one precision part required
- Adjustment percentage displayed to user for diagnostic use
- Alarm limits to trap hardware failures and out of range adjustments

4 Effect of a significant dynamic temperature deviation on different system parameters, and their compensation

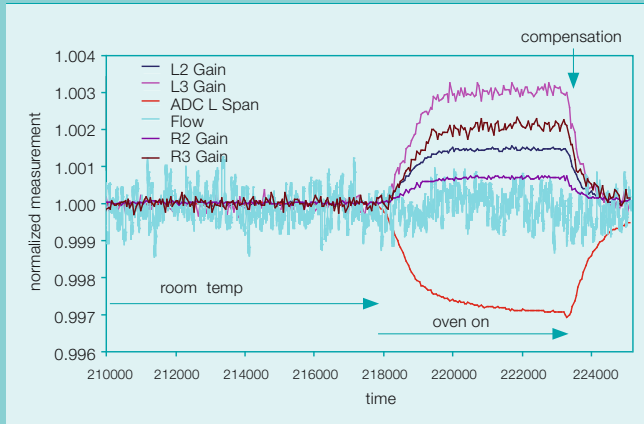

verter **3a**. This is directly applied to the same front-end amplifier **3b** that is used to amplify and process the electrode signals.

The novel aspect of this approach is that it is not the actual absolute value of the signal on which the measured value is based, but its gain. By using multiplexers (**3c** and **3d**) to route the voltage reference directly into the ADCs, the system performance is rendered independent of the gains, offsets or stability of any of its components – and the output does not depend on the magnitude of the voltage reference.

The product's performance has been proven to depend on only one component: the resistor that is necessary to convert the current through the coils into a voltage for measuring the coil current. **4** illustrates how well the

new system compensates for temperature-dependent parameter changes in its components.

Compared with a traditional transmitter design, which often depends on the performance of about ten or so precision components, the reduction to a single item permits stability and performance to be boosted to unparalleled levels. **5** shows the degree of adjustment the transmitter undergoes in responding to temperature changes. **6** shows the over-

all transmitter stability over a wide temperature range. In the measurements that produced these figures, the temperature was reverted to 20°C after each temperature change – illustrating the excellent reproducibility of the measurement.

Since the system automatically adjusts itself, no precision parts are required in the measurement chain.

ABB's implementation of the auto calibration system in an electromagnetic flowmeters is a world first, leading to unparalleled stability and performance. The product was launched in Barcelona on November 7, 2007.

5 Internal auto-gain adjustments made by the transmitter to respond to temperature changes

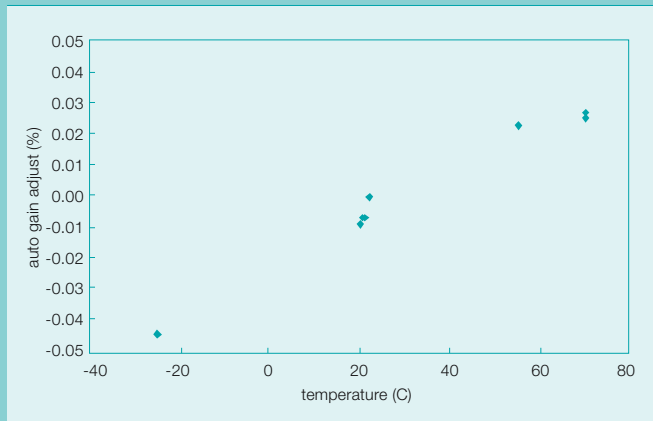

6 Overall transmitter span shift versus temperature. Temperature was always returned to 20°C between measurements, illustrating the device's high reproducibility

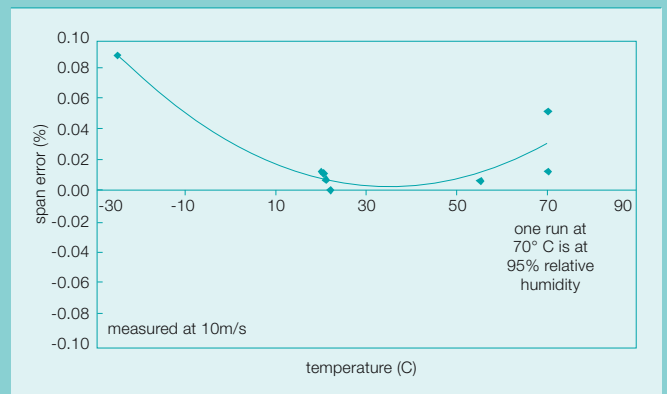

Plugged impulse line detection on a differential pressure transmitter

A faulty measurement can have significant negative implications for a process, hence the importance of being able to detect such errors as soon as they occur. When it comes to differential flow measurements, blocked impulse lines are especially tricky to discern as the results continue to look plausible. ABB has found a way to identify these – using the background noise of the process.

A differential pressure transmitter is a device used to sense the pressure between two points of a process. Its main application is the computation of the flow rate in a pipeline. This is achieved by measuring the pressure drop caused by a so-called primary element. This element is inserted in the flow causing local pressure changes. The pressure difference between two points is measured and the flow rate computed from this value using knowledge of the geometry of the primary element. Differential pressure transmitters are connected to the process through two pipes called impulse lines **7**.

When it comes to differential flow measurements, blocked impulse lines are especially tricky to discern as the results continue to look plausible.

During the operating life of the transmitter, these connections can get plugged (blocked) due to solid material in the process, or to limestone or freezing of the fluid. Significant maintenance efforts are required to prevent this. Maintenance is made even more challenging by the fact that, in contrast to most other malfunctions that can occur in field devices, a plugged

impulse line has no impact on the device hardware; if it happens unnoticed, the measurement value retains a plausible value. This makes the detection of such errors especially elusive.

However, all is not lost: Experiments have shown that the plugging condition can be diagnosed through analysis of the sensed differential pressure signal. Based on these results, a method for the automatic detection of the plugged-impulse-lines condition was developed and a corresponding algorithm implemented in an ABB differential pressure transmitter of the 2600T series.

The major cost-saving benefit of plugged impulse line detection comes from the reduction of preventive maintenance.

The principle of Plugged Impulse Line Detection (PILD) is based on empirically revealed characteristics of the observed time-series of the pressure detection. Flow processes are affected by fluctuations of the pressure value

caused by other devices and machines interacting with the process. An example is a pump producing a differential pressure signal noise. Under normal operating conditions, without any plugged impulse line problem, this process noise is mostly canceled out, because the device measures the pressure difference between two relatively close locations. The blocking of one impulse line leads to the pressure fluctuations not being canceled anymore – the process noise therefore appears in the differential pressure signal. Finally, when both impulse lines are plugged, the noise level of the sensed differential pressure is almost reduced to zero.

7 Differential pressure transmitter connected to an orifice plate

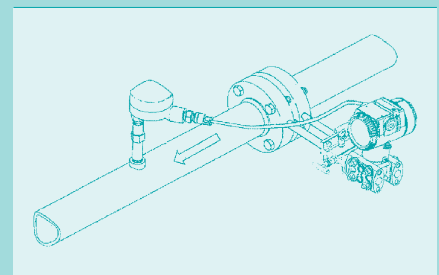

8 Signal power **a** without plugging, **b** and **c** with individual lines plugged and **d** with both lines plugged

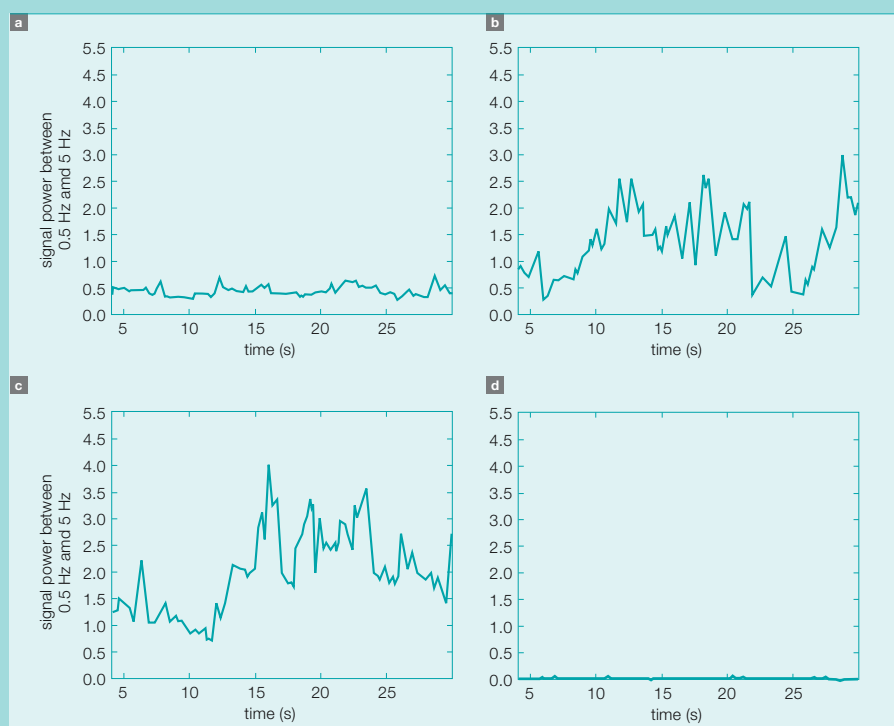

Product innovations

9 Plugged Impulse Line Detection (PILD) output

Severity	Condition	Sub Condition	Description	Timestamp	Quality Status
1	Configuration	Normal		11/30/2005 12:14:33 PM	good
1	Electronics	Normal		11/30/2005 12:19:45 PM	good
1	Pressure Sensor	Normal		11/30/2005 12:08:46 PM	good
1	Impulse Lines	Failure	Process and installation related. PILD-HIPM has detected a plugged impulse line on the HIGH side.	11/30/2005 12:20:06 PM	good
1	Compliance with operating conditions	Normal		11/30/2005 12:19:56 PM	good

The major cost-saving benefit of plugged impulse line detection comes from the reduction of preventive maintenance. The output of the PILD algorithm should be available from the maintenance workplace and in the control room. The condition of all transmitters can be monitored from one central access point via Fieldbus and Asset Monitoring. This enables a transition from a preventive maintenance setup to one with reactive maintenance based on reaction times 9.

From these observations it can be generalized that:

- The plugging of a single impulse line 8b and 8c leads to a higher noise level than for the no-plugging case 8a.
- The plugging of both impulse lines leads 8d to a lower noise level than for the non-plugging case.

The new algorithm is self-adapting to the specific process conditions at the time of installation. It is able to detect the plugged-impulse-lines events with a degree of robustness with respect to variations of the process conditions. The conclusions depicted above are confirmed by the publications of the University of Sussex [3, 4, 5] and by ABB laboratories [6].

Wireless – the future for instrumentation

Wireless technology has many advantages: Costs of wiring (and the associated risk of error) are saved and changes are easier to implement. ABB is supporting the introduction of the technology and is cooperating with other vendors to implement joint standards.

Wireless technology has invaded everyday life at many levels, from mobile phones to door bells, from TV remote controls to Internet hot spots and WIFI. It may seem stranger, therefore, that wireless has taken so long to arrive in process automation – and this despite the benefits being clear and end-user interest levels high Factbox 2.

The reason for the relatively slow development of wireless for process automation becomes more understandable when the special require-

ments are considered. These include: reliability, security and simplicity.

The oil and gas sector was among the first to recognize the benefits and requirements of a wireless network at instrument-level.

Resulting from trials with significant vendors such as ABB, the oil and gas sector was amongst the first to recognize the benefits and requirements of a wireless network at instrument-level. These early stage trials used proprietary networks, which often had the drawback of restricting vendor choice, while also failing to fulfill the three requirements listed above. They did, however demonstrate the technology's potential to reduce operational expenses. The industry has now moved on from the trial phase and is looking for an open standard to satisfy these requirements and provide a multi-vendor wireless network.

There are two groups that are currently working on a wireless standard for process automation. While they both





share the same radio technology (802.15.4) they are otherwise incompatible. These two competing standards are HART 7 and ISA SP100.

Of the two, WirelessHART will become available first as its standard has already been written and passed a ballot of member companies. A dem-

onstration of WirelessHART instruments took place at the ISA show in September 2006 including instruments from ABB, Emerson and Siemens.

Factbox 2 Benefits of a wireless network for process automation

Plant availability

- A low-cost option to add condition monitoring to critical assets (positioners – analyzers) to reduce unexpected down time
- Wireless access can either be built into Instruments or added via a loop-powered adaptor

Process variation

- A low-cost option to add process monitoring points previously too expensive to consider
- Adds short-term low-cost process monitoring points to help solve difficult process problems

Comply to safety and environmental legislation

- Low-cost option to monitor safety shower operation

Low-cost option to monitor

- Gas detectors
- Water effluent
- Gas emissions
- Relief valve operation
- Steam traps

Process monitoring

- Access multivariable information (eg, mass gas flow devices)
- Monitor remote or inaccessible points (cable may need routing under roadways or long distances)
- Compare analog to digital signals (read back Valve position and compare to set-point)

Sean Keeping

ABB Automation Products, Instrumentation
St. Neots, UK
sean.keeping@gb.abb.com

Eugenio Volonterio

ABB SACE S.P.A.
Lenno, Italy
eugenio.volonterio@it.abb.com

Ray Keech

ABB Automation Products, Instrumentation
Stonehouse, UK
ray.keech@gb.abb.com

Gareth Johnston

ABB Automation Products, Instrumentation
St Neots, UK
gareth.johnston@gb.abb.com

Andrea Andenna

ABB Corporate Reserach
Baden-Dättwil, Switzerland
andrea.andenna@ch.abb.com

References

[1] OIML International Recommendation, R49-1, "Water meters intended for the metering of cold potable water and hot water."
 [2] UK Patent Application. Wray T, 30799GB
 [3] **Zhu, H., Higham, E. H., Amadi-Echendu, J. E.**, Signal Analysis applied to Detect Blockages in Pressure and Differential Pressure Measurement Systems, IEEE Instrumentation and Measurement Technology Conference, Proceedings Vol. 2 (1994), pp. 741–744.
 [4] **Zhu, H., E. H.Higham, Amadi-Echendu, J. E.**, The Application of Signal Analysis Methods in Orifice Plate-Differential Pressure Flow Measurements, Technical report, University of Sussex.
 [5] **Amadi-Echendu, J. E., Zhu, H.**, Detecting Changes in the Condition of Process Instruments, IEEE Trans. On Instrumentation
 [6] **Andenna, A., Eifel, D., Invernizzi, G.**, Embedded diagnosis to detect plugged impulse lines of a differential pressure transmitter, Technical paper ABB Schweiz AG, ABB Forschungszentrum, ABB SACE S.p.A.

Performing at a higher level

Advanced heat pipe cooling increases circuit breaker performance by over 25 percent

Daniel Chartouni, Martin Lakner, Giosafat Cavaliere



A generator circuit breaker (GCB) is a core component of a power plant, protecting both the generator and the power transformer. ABB's current breaker portfolio includes breakers with rated nominal currents ranging from 6300 A to over 50,000 A. HECS breakers are designed for nominal currents up to 18,000 A. However, a side effect of these large currents is heat dissipation in the device, which must be limited if other system components are to remain within their rated temperature tolerances. Natural cooling limits the rated nominal current and therefore many of today's GCBs employ forced cooling methods to increase nominal current levels. However, these "forced" coolers also limit nominal current capability.

To increase GCB nominal currents, an innovative cooling method was required to meet the ever-increasing demand for lighter, cheaper and more powerful devices. Using so-called heat pipes to achieve efficient heat transfer, not only have they developed two products that are lighter and more robust than previous versions, but GCB performance has increased by over 25 percent!

Power devices are following the trend of most other electrical products by becoming smaller and lighter while at the same time incorporating greater functionality. Cost efficiency is for the most part the main driving force behind this because a lighter device results in lower material, transportation and installation costs. One part of ABB's Generator Circuit Breaker (GCB) family **Factbox 1**, the HECS breaker, has gone through this process with impressive results: by replacing a so-called "forced" cooling system (ie, one that needs pumps, fans or motors to operate) with a "passive" cooling apparatus (one that operates without the need for pumps, fans or motors), nominal HECS breaker current has been increased from today's 18,000 A to 23,000 A! Using an innovative approach based on a heat pipe cooling concept, ABB engineers have transformed members of this family of devices into silent, slimmer and lighter versions of their former selves with extremely low-maintenance requirements **Factbox 2**.

Efficient heat transfer in ABB's HECS circuit breakers demanded a purely passive and low-maintenance device if nominal current values were to be increased.

Knowing what to do

Nominal and short-circuit currents generate a tremendous amount of heat. Even tiny electrical resistances (resulting from the material or sliding electrical contacts) lead to ohmic losses, which can generate kilowatts of heat. However, the steady state temperature at the hot spot has to be limited to 105°C¹⁾ during normal (closed) operation, thereby thermally limiting the maximum allowable nominal current. Hence, the operating temperature of the generator circuit breaker is determined by both the nominal current and the cooling of the device. To successfully increase the rated nominal current of its GCBs, engineers had to focus on the thermal management of the GCB.

Factbox 1 ABB's Generator Circuit Breaker (GCB) portfolio

ABB's GCBs are widely used in all kinds of power stations, such as gas turbine, combined cycle and thermal power plants, as well as geothermal, hydro and pumped storage power stations. Currently the company has a market share of some 70 percent. The breaker portfolio covers devices with electrical power ratings from 100 MVA to over 1500 MVA. Included are breakers with rated nominal currents ranging from 6300 A (and a maximum short-circuit current of 63 kA) to over 50,000 A (with a short circuit current rating of 210 kA). Introduced in 2003 and available for both indoor and outdoor application, HECS breakers are rated for the power range up to 800 MVA. They can switch short-circuit currents up to 130 kA and are suited for nominal currents of up to 13,000 A using naturally cooled



systems and 18,000 A with forced cooled systems.

The power density is very high considering their small size and weight – typically 6000 kg. They are therefore ideal for retrofitting in existing power plants, and allow substantial savings in transportation and installation costs.

Factbox 2 Overview of the new products resulting from heat pipe implementation

New product name	Maximum operating current	
	Today's HECS-based product	New product with heat pipe (passive cooling)
HECS-100/130XLp	18,000 A (with forced cooling)	18,000 A
HECPS-5Sp (pump storage solution)	13,500 A	18,000 A
HECS-130XXLp	Not available	23,000 A

Within ABB's HECS breaker family, nominal currents of up to 13,000 A are possible using natural cooling methods. However, a forced air-to-air cooling device – itself a heat generator as well as a source of extra weight – is required to increase this value to a maximum of 18,000 A. Increasing the nominal current of a given breaker to 23,000 A can therefore be achieved only by improving the heat transfer from the HECS conductor to the environment while at the same time ensuring that the temperature of sensitive components stays within a tolerable range. This challenge was made even more taxing given that the heat source (the conductor) is on a high electrical potential of 25.3 kV while the heat sink (the HECS enclosure) is ground-

ed, and any form of forced cooling has undesirable side effects. If efficient heat transfer across this large electrically isolated gap was to be achieved, a purely passive and low-maintenance device was needed. And such a device was realized using heat pipes²⁾ **Factbox 3**.

Product development

Even though it has been around for several decades, the heat pipe con-

Footnote

¹⁾ The IEEE standard allows a temperature increase of 65 K for silver-coated contacts above an ambient temperature of 40°C.

²⁾ The principle of the heat pipe has been around for several decades, and cooling systems in the consumer electronics industry use the idea.

Product innovations

1 A single pole of a heat pipe cooled HECS breaker. From the outside, only the condenser fins are visible on the upper section of the encapsulation



2 Evaporator and isolating section attached to the connection chamber. The vapor flows through the waved insulating tube to the condenser (see 3)

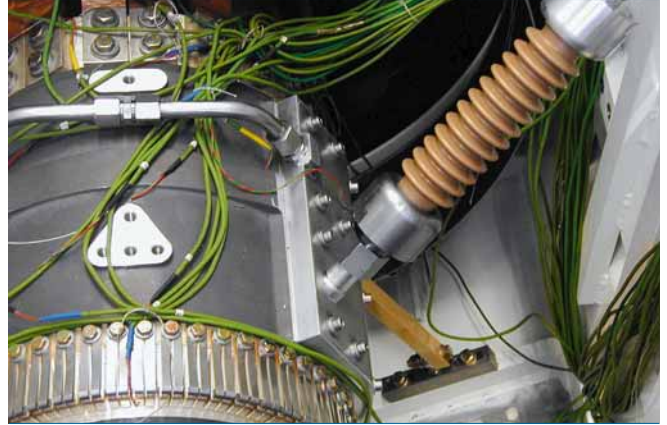

cept was never applied to GCB cooling because of the challenge of using electrically insulated heat pipes where a large potential difference exists between the heat source (the evaporator) and sink (the condenser). This in turn ruled out a design composed entirely of metallic components, requiring instead a solution that provides mechanical robustness and material compatibility between the heat pipe materials and the working fluid. Overall, the following requirements for a successful solution needed to be met:

Thermal management

The maximum total heat load to be transferred is determined by the current and the resistances in the circuit breaker. The number of heat pipe systems therefore determines the maximum allowable thermal resistance for the individual components.

Heat pipe dielectric design

This refers in particular to the dielectric insulation between the conductor and the enclosure for normal operating conditions (namely around 25 kV) and for other voltages the system needs to be protected against, for example those generated by lightning impulses. The solid insulators of the heat pipes as well as the working fluid must also comply with this requirement.

Heat pipe mechanical design

The system must be able to tolerate a high number of switching operations (20,000 cycles), transport and earthquakes.

Long term stability and environmental considerations

The system needs to be maintenance-free for over 20 years. In addition, the

working fluid needs to be environmentally friendly for at least 20 years. Environmental protection requires low global warming and ozone-depletion potential. The LCA (Life Cycle Assessment), which compares the novel cooling device to the current forced air-to-air cooler, needs to show that the heat pipe solution is indeed more environmentally friendly.

3 Heat pipes attached to the HECS GCB. The transport sections are connected to the condensers that are incorporated into the enclosure

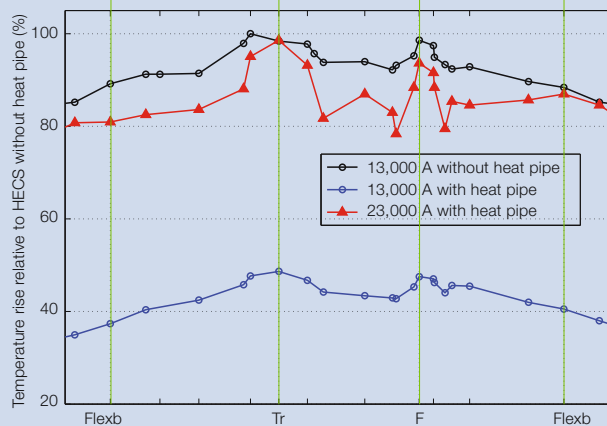

The temperature rise along the conductor, relative to the maximum temperature rise of HECS L, is well below the limit of 65 K given in the IEEE standard

Using an innovative approach based on a heat pipe cooling concept, ABB's HECS breakers have been transformed into silent, slimmer and lighter versions of their former selves.

Technical realization

A standard GCB consists of three parallel phases. Each GCB conductor is housed in an individual enclosure which is insulated from the pole frame. In the ABB design, each phase has six heat pipes, and the heat generated by a nominal current has to be transferred to the ambient through these heat pipes. To do this as uniformly as possible, the conductor area covered by the evaporator

was maximized³⁾ 2. Homogeneous heat dissipation to the six evaporators is needed to ensure that no hot spots occur inside the conductor material due to the non-vanishing thermal resistance of the material itself. The isolating section actually proved quite challenging in that its dielectric stability had to be ensured, as well as its mechanical integrity against breaker operation, not to mention air and working fluid diffusion⁴⁾. Results taken during the testing phase are shown in 3. Not only has the nominal current been increased by 27.8 percent, from 18,000 A to 23,000 A, but the measured thermal resistance using the heat pipe solution was 58 mK/W. In other words, the temperature increase for a heat dissipation of 1000 W is only 58 K.

Looking to the future

ABB's portfolio is the widest available on the GCB market. Upgrading the existing HECS-XL breaker with the passive heat pipe cooling system, as well as the creation of two new products, HECS-100/130XXLp and

HECPS-5Sp, for standard and pump storage applications, will extend this portfolio even further Factbox 2.

ABB's new heat pipe solution needs no electricity to operate, requires little maintenance and has helped increase circuit breaker performance by over 25 percent!

The HECS-100/130XL breaker currently uses a forced cooling system. ABB's aim is to keep the market leadership with a substitute for HECS XL. This version would be feasible either with small attached evaporators and smaller condensers or with a reduced number of full-size heat pipe systems. Of the proposed new products, the HECS-100/130XXLp breaker product is aimed at the market segment between 18,000 A and 23,000 A. The maximum possible evaporator surface has been chosen for this version, guaranteeing

a very low thermal resistance and a homogeneous temperature distribution along the disconnecter profile. Another important parameter in this design is the condenser surface area mainly because it influences the thermal resistance along the heat pipe system. Equipping the HECS-5S breaker – a pump storage solution – with a heat pipe cooling system would extend its nominal current to 18,000 A.

ABB's new heat pipe solution needs no electricity to operate, requires little maintenance and is impressively silent. Its main benefit, however, is the extension of the HECS generator breaker nominal current to 23,000 A. Not only will this new passive cooling solution contribute to further complete the company's circuit breaker portfolio, but it will also allow for a very cost-efficient product for each kind of application. These products will make their market debut in 2008.

Factbox 3 Heat pipes as an alternative cooling concept

A heat pipe is a device that makes use of the effect that a liquid absorbs heat when it is evaporated (latent heat of vaporization) and that this heat can subsequently be released somewhere else during the condensation process.

The system is composed of three major components: an evaporator section which is attached to the GCB conductor (heat source); a transfer section; and a condenser section located in the cooler environment outside the enclosure.

It operates like a closed-loop system that is partly filled with a working fluid. Inside the evaporator, the heat flux causes the working liquid to boil.

A small pressure imbalance then carries the vapor to the condenser section where the heat is dissipated by natural convection cooling to the outside of the GCB enclosure.

Following the condensation process, the liquid returns to the evaporator via a gravity heat pipe. An outstanding characteristic of this pipe is that it is driven only by the heat that is being transferred and by the gravity

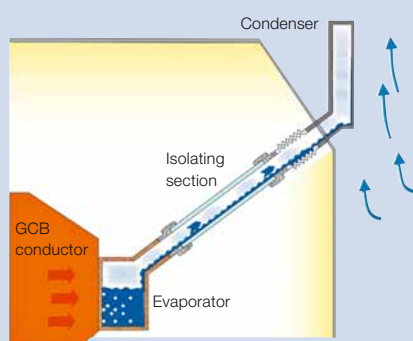

that returns the condensed liquid, making it a purely passive device.

Because the fluid boils and condenses at roughly the same temperature, the temperature gradient along the pipe is small, leading to efficient heat transfer and a heat flux value that may be several thousand times higher than that in good metallic thermal conductors.

The heat flux from the evaporator to the condenser is limited only by the vapor flow properties inside the transport section.

Daniel Chartouni

ABB Corporate Research
Baden-Dättwil, Switzerland
daniel.chartouni@ch.abb.com

Martin Lakner

Giosafat Cavaliere
ABB High Voltage Products
Zürich, Switzerland
martin.lakner@ch.abb.com
giosafat.cavaliere@ch.abb.com

Footnotes

³⁾ Doing this also reduces the thermal resistance of the evaporator.

⁴⁾ At the beginning of the project, it was thought that the insertion of an electrically insulating tube, carrying liquid and vapor, between the evaporator and the condenser would be straightforward. However, challenges arose because official type tests needed to be carried out for voltages up to 88 kV AC and 165 kV (lightning impulse voltage). Additionally, the tube has to be mechanically very strong (metal cannot be used), and finally the connection at both ends of the tube to the rest of the pipe must be very tight.



A touching movement

Force control turns machining robots into universal tools

Peter Fixell, Tomas Groth, Mats Isaksson, Hui Zhang, Jianjun Wang, Jianmin He, Martin Kohlmaier, Rainer Krappinger, Jingguo Ge

ABB has written a new chapter in the book of robot applications. While in the past it had been a tedious and time-consuming effort to program a robot for delicate fine-tuning operations, robots can now learn how to best manage such tasks themselves. This innovative approach can reduce overall programming times by up to 80 percent for robots used to grind castings, vastly improving productivity levels.

With ABB's new Flex Finishing system featuring RobotWare Machining FC (force control), one of the last real barriers to productivity improvement in this sector has been lifted.

Achieving fast robot movement while assuring contact stability with the workpiece has long been a challenging task for robot application engineers. ABB pioneered this area several years ago, developing robots that could carry out delicate assembly tasks in the automotive industry [1]. This progress was made possible by using sensors to measure the contact force, and feedback loops to control the force and couple it to the movement of the robot arm. With these force-controlled robots operating on the basis of the S4Cplus robot controller, the assembly time for power trains could be reduced by as much as 75 percent.

A further step in the use of force-controlled robots has recently been made in a more complex class of application: grinding, deburring¹⁾ and polishing of units produced in, for example, a foundry. Unlike part assembly, the control of the process forces in these applications is much more demanding and so far has not been possible. There are several reasons for the higher complexity: The tools wear, the parts have different dimensions and the fixtures are not 100 percent accurate and repeatable, with the risks of large position deviations and inconsistent results.

Traditionally the finishing process has been very labor intensive, and the quality of the finished product has been inconsistent with casts ground, deburred and polished by hand. Until now, robots used for this task were

position-controlled with compliant tools and fixtures, moving according to defined trajectories and speeds, sometimes supported by an extra servo drive to adjust for the differences in dimensions. In this mode of operation, if the robot cannot reach the trajectory because the part is not correctly located, it still will try to cut through the part. As a result, the robot stops, the tool breaks or the workpiece gets damaged. To limit such damage, conventional cast-cleaning robots typically run at a slower pace with limited productivity. Due to the need for position control, these robots must be programmed to meet high path accuracy, a very time-consuming effort for an engineer. All these disadvantages – high programming effort, extra tooling, additional servo motors and the considerable risk of damage – were slowing the spread of robot applications in this industry.

Five steps to a major innovation

The new, unique robot application, which ABB launched in 2007, combines five innovative elements:

- Use of the latest ABB robot controller, IRC5, with its high-speed sensor interface
- A programming environment that allows the robot to find the optimum path itself
- A feedback loop to control the pressure of the tool
- A feedback loop to adjust the speed of the tool
- An easy-to-use, pre-engineered product offer

IRC5 is built on the industry's most advanced operating system for controlling robots and peripheral equipment. Featuring RAPID language and ABB's Motion Technology and Communication, RobotWare OS is the most powerful controller operating system available today. IRC5 has two Ethernet channels – one for LAN and one for local connection – as well as two serial channels for point-to-point communication with sensors. The bandwidth provided by the IRC5 controller is critical for the overall performance and reaction time of the robot in correcting and adjusting its position. To realize the correct sampling rate to adjust the dynamic robot positioning, the sensor must be highly integrated with

1 IRC5 controller and FlexPendant



Footnote

¹⁾ Deburring is the removal of burrs (ie, protruding edges) from a casted or machined part.

2 Measured contact force when grinding a turbine blade in seven sequential sweeps; the blue curve shows results with traditional position control, and the red curve shows the consistency achieved with Force Control

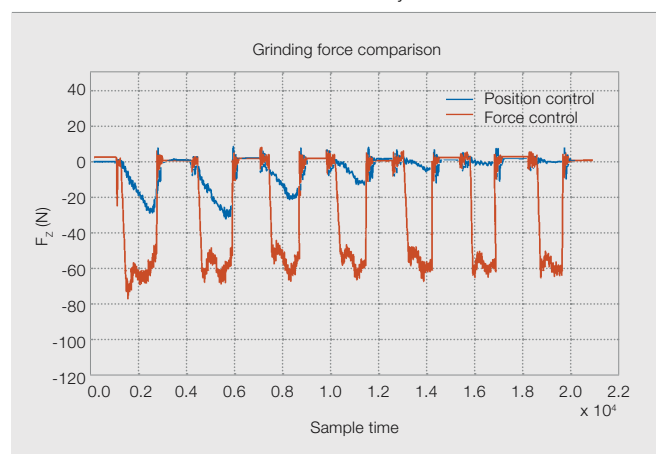

Product innovations

the controller electronics for the success of the innovative application.

IRC5, equipped with ABB's Motion Technology MultiMove, is a world benchmark, allowing the control of as many as four robots (36 axes) at a time **1**. Common work objects can be shared among robots, enabling complex coordinated patterns. MultiMove also facilitates a dynamic switch between independent and coordinated motion. This unique performance makes it possible to address the complex tasks of grinding, deburring and polishing.

The programming environment that supports the user of this innovative application is the first ever to offer this new dimension of programming.

3 Robot with Force Control Function package



It allows simple and efficient programming by using the force sensor itself to define the trajectory for the robot movement. The programming is managed from the FlexPendant and from a dedicated application module for creating the program for Force Control Machining. The concept gives the operator the ability to move the robot by hand and teach it the rough path. Afterwards, the robot will automatically use the rough information to follow the part; at the same time, it will automatically record the exact path and generate a robot program **2**.

The cycle time of the robot in operation is reduced by about 20 percent with enhanced control, and the lifetime of the grinding tools also can be extended by 20 percent.

The feedback loop, FC Pressure, lets robots grind, polish or buff castings while maintaining a constant pressure between the tool and the work surface. FC Pressure software is aimed at processes demanding a high-quality surface finish. It allows the robot to effectively "feel" its surroundings and follow the casting surface, changing its position to apply a constant pressure on the surface, even if the exact position of the surface is unknown. As there is consistent contact, debris

such as a burr is removed to the same depth.

The result is improved surface finish, the ability to handle variations in castings, a minimum risk of damage to the casting surface and predictable tool wear. Since pressure is obtained by moving the robot path, this function is especially suited for polishing, grinding and cleaning, where a surface must be even and smooth **3**.

The second software feature, FC SpeedChange, enables a robot to deburr or deflash casting surfaces at a consistent speed, slowing down when encountering excessive burr. In processes where path accuracy is important and where the finished result must comply with specific dimensions, FC SpeedChange is the right choice. With FC SpeedChange, the robot is position-controlled and follows a programmed path that maintains a constant material removal rate. It operates at the maximum process speed, automatically slowing down the robot when the machining forces are too high to minimize changed dimensions due to deflections of the robot arm, and to avoid subsequent damage to the part or tool due to stress and heat. As in the case of FC Pressure, this results in shorter cycle times, the ability to handle variations in castings, a minimum risk of damage to the castings and predictable tool wear **4**.

The final product comprises advanced sensor signal processing, mathematics, logic solution and a graphical user

4 Grinding process where the robot slows down when encountering excessive burr. The measured process force exceeds the set reference value, which triggers the robot to slow down. When the force is decreased, the robot will accelerate to the programmed speed in 0.1 s

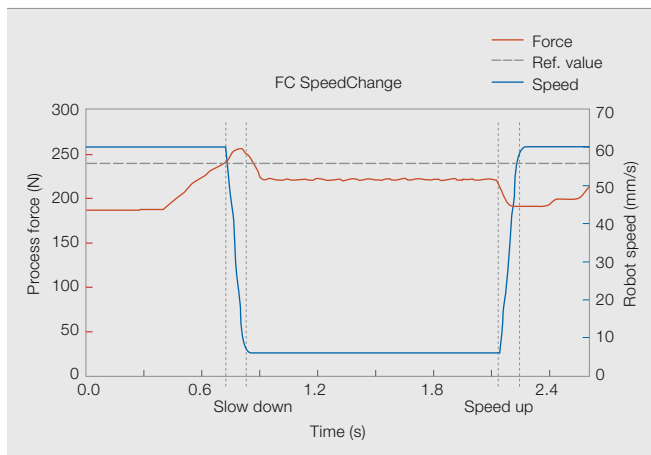

- 5 The graphical user interface as seen on the FlexPendant. The path is presented in a 3D view for easy graphical overview and editing



interface for quick, easy and accurate programming, in which the sensor is used to let the operator guide the robot by hand for intuitive hands-on programming. The “plug-and-operate” product offer contains all the parts needed, with the sensor, electronics and cabling mounted and tested on the robot, leaving only the process adaptation to the integrator or customer.

A concerted action for success

As is the case with most major innovations, developing this system was a collaborative effort. The work of many university and ABB researchers, ABB engineers and customers had to come together to complete this complex, multi-disciplined task.

ABB and Lund Technical University took the first steps together to define and implement the basic sensor and control functions [2,3]. From this perspective, it became necessary to gain a better understanding of the application and to find the optimum user interface [4]. The clear path to success was to involve the global resources of ABB – the Force Control concept and implementation from Sweden and the United States, application knowledge from Austria and the graphical user interface from China, as well as real test cases provided by industrial partners. The Rimrock Corporation’s John Kuhn, who performed the real-time tests, said, “The Force Control product has the potential to impact our business more than any past ABB product release to date.” The Rimrock Corporation is a premier supplier of automation products and integration services for North America and a long-time, valued partner of ABB.

A strong market pull

When RobotWare Machining FC was first presented to the public at the GIFA, the world’s largest foundry fair in Düsseldorf, the customer resonance was overwhelming. Customers clearly realized the improved product quality and significant cost savings in engineering time, which can be as much as 80 percent now. Moreover, the cycle time of the robot in operation is reduced by about 20 percent with the enhanced control, and the lifetime of the grinding tools also can be extended by 20 percent.

After the successful launch of Force Control technology for assembly and machining applications, ABB is making an impact in new areas. One such area is the aerospace industry where accurate, reliable and efficient robot drilling is required for flexible production [5].

Now, with RobotWare Machining FC, product finishing operations in foundries are much simpler, enabling finished castings to be produced better, faster and cheaper.

- Robot with sensor, fixture and stationary spindle for deburring

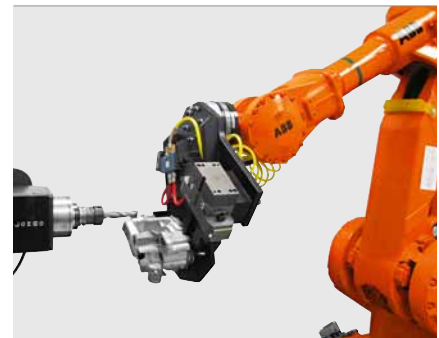

Peter Fixell

Tomas Groth

Mats Isaksson

ABB Robotics

Västerås, Sweden

peter.fixell@se.abb.com

tomas.groth@se.abb.com

mats.isaksson@se.abb.com

Hui Zhang

Jianjun Wang

Jianmin He

ABB Corporate Research

Windsor, CT, USA

hui.zhang@us.abb.com

jianjun.wang@us.abb.com

jianmin.he@us.abb.com

Martin Kohlmaier

Rainer Krappinger

ABB AG, Robotics

Wr. Neudorf, Austria

martin.kohlmaier@at.abb.com

rainer.krappinger@at.abb.com

Jingguo Ge

ABB Corporate Research

Shanghai, China

jingguo.ge@cn.abb.com

References

- [1] Zhang, H., Gan, Z., Brogard, T., Wang, J., Isaksson, M. Learning skills – robotics technology in automotive powertrain assembly. *ABB Review* 1/2004, 13–16.
- [2] Johansson, R., Robertsson, A., Nilsson, K., Brogårdh, T., Cederberg, P., Olsson, M., Olsson, T., Bolmsjö, G. (2004). Sensor integration in task-level programming and industrial robotic task execution control. *Industrial Robot*, 31(3), 284–296.
- [3] Blomdell, A., Bolmsjö, G., Brogårdh, T., Cederberg, P., Isaksson, M., Johansson, R., Haage, M., Nilsson, K., Olsson, M., Olsson, T., Robertsson, A., Wang, J. (2005). Extending an industrial robot – implementation and applications of a fast open sensor interface. *IEEE Robotics Automation Magazine*, 12(3), 85–94.
- [4] He, J., Pan, Z., Zhang, H. (2007). Adaptive force control for robotic machining process. American Control Conference, ACC '07, 1–6.
- [5] Kihlman, H., Brogårdh, T., Haage, M., Nilsson, K., Olsson, T. (2007). On the use of force feedback for cost efficient robotic drilling. Paper 07ATC-278 presented at the SAE 2007 AeroTech Congress & Exhibition, Los Angeles, CA.

A higher level of efficiency

Five-level frequency converters for medium voltage
Pieder Jörg, Gerald Scheuer, Per Wikström

The depletion of energy resources and the release of greenhouse gases into the atmosphere is of growing concern to mankind. ABB is responding to the challenge by promoting energy efficiency.

One area with huge potential for savings is in motors that operate fans, pumps and compressors. These are usually driven by fixed-speed motors, with the flow being controlled by energy-wasting throttling methods. Frequency converters cut out this waste by adapting the speed of the motor to directly match the required pressure or flow.

So is the problem solved? Not totally. There are two basic problems to be overcome in designing frequency converters for medium voltage: These are reaching the voltage of the motor and getting closer to an ideal sinusoidal voltage. ABB's innovative solution lies in the re-combination of existing solutions to solve both of these problems.

A five-level arrangement means there are five output levels instead of the usual two or three. This step delivers a considerable improvement in the waveform, while at the same time achieving a higher output voltage. And to crown the success, the innovation was realized by drawing largely on proven concepts, reducing risk and bolstering reliability.

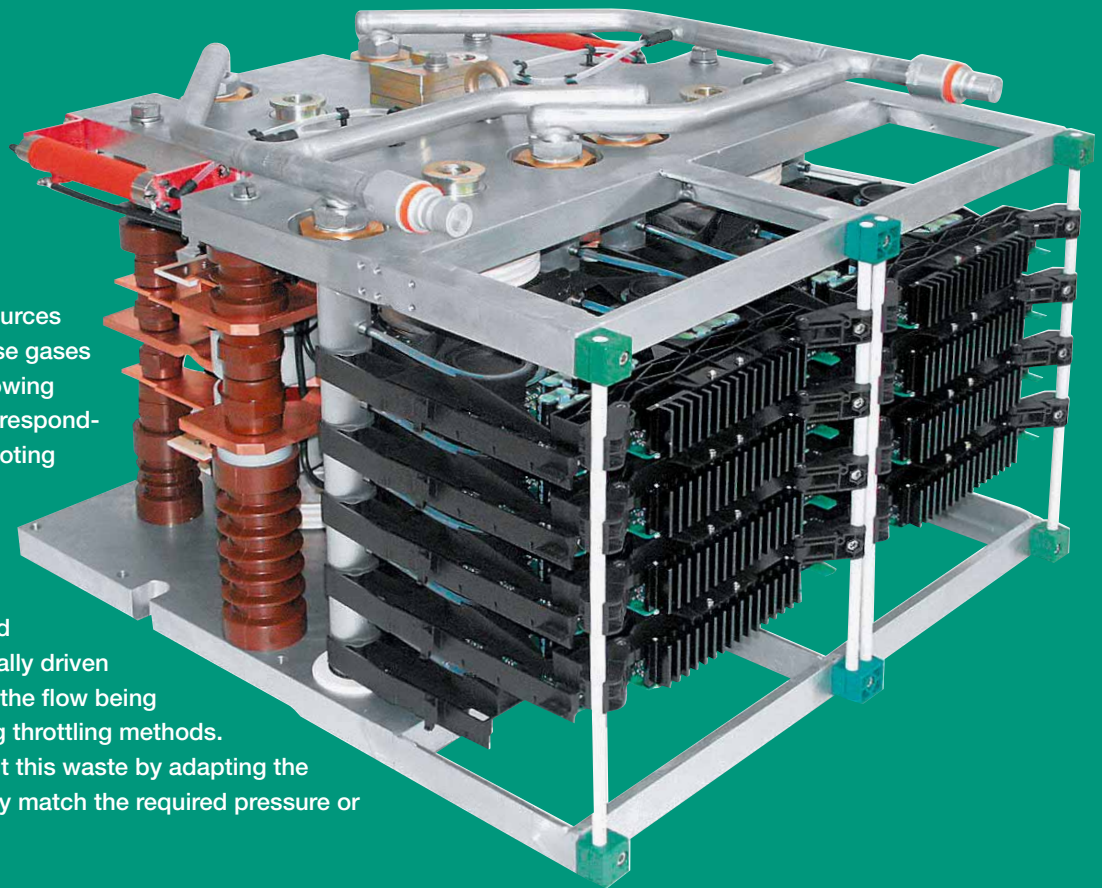

Traditional control strategies for flow control usually rely on wasteful “throttling methods.” To use a simple analogy, this is like driving a car by placing a brick on the gas pedal (fixed supply) and using the brake pedal for speed control (friction-based throttle). Frequency converters are the variable gas pedals of motor control, and represent a huge potential for energy savings.

Motors consume around 30 percent of all the electric energy produced in the world. About three-quarters of all motors power pumps, fans or compressors used in applications where energy consumption can be reduced through speed control. An ABB estimate shows that the worldwide adoption of such frequency converters in medium voltage drives can deliver savings of 227 TWh – in other words, the output of 144 fossil fuel power plants or the total energy consumption of a country such as Spain¹⁾.

At present, less than ten percent of all motors sold every year are equipped with the most efficient speed control that exists: the frequency converter. Despite also being the least maintenance-intensive means of motor control available, customers are still opting for other means of control in the majority of cases. Why? The most frequently mentioned barriers for adopting the technology are:

- reliability
- harmonics
- cost and/or very short payback requirements

ABB’s innovative five-level switches address all of these challenges.

Better waveforms, higher voltages

Electricity generated in the traditional manner using a synchronous generator has a sinusoidal output voltage. Electric motors that are connected directly to the mains grid (direct-on-line connection) and hence operated at fixed speed are optimized for this type of waveform. If the same motor

1 A motor connected direct-on-line **a** and with a frequency converter inserted between the main grid and the motor **b**

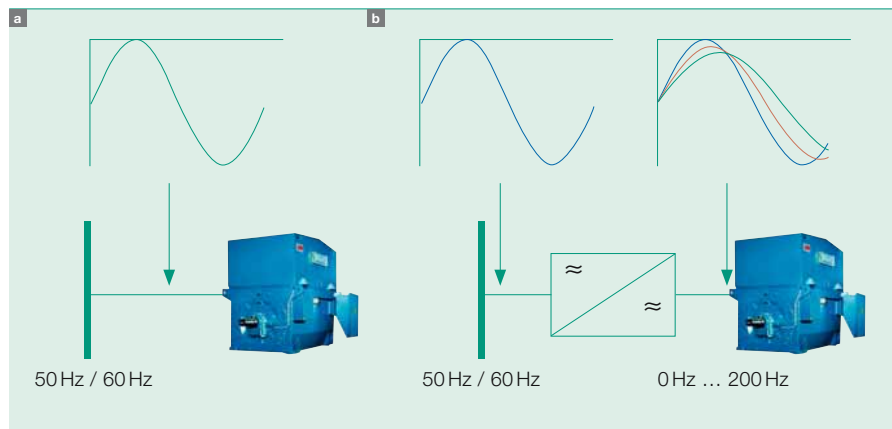

design is to be used for a variable speed application, the frequency converter should deliver a waveform that is as close to the ideal sinusoidal shape as needed. Deviations from the ideal waveform lead to additional heating of the motor. This in turn means the motor cannot be used to its full power and must be de-rated. Another negative implication is that a superimposed torque ripple can cause torsional oscillations in the drive-chain and machinery.

Motors consume around 30 percent of all the electric energy produced in the world. About three-quarters of all motors power pumps, fans or compressors used in applications where energy consumption can be reduced through speed control.

Furthermore, motors come in standardized voltage classes. For the medium voltage (MV) range of motors for powers of up to about 7000 kW, the most frequent voltages found on industrial sites are 6 kV/50 Hz and 4 kV/60 Hz. This means that, in order to use the same range of motors in both direct-on-line connections **1a** and with frequency converters **1b**, the output of the frequency converters has to be able to attain similar voltage values.

Such output voltages are not easy to attain with traditional two- and three-level converters as the maximum output voltage is determined by the voltage ratings of the power semiconductors.

Inside a frequency converter circuit

The energy conversion in a converter is realized in two steps: In the first, the energy supply in the form of a sinusoidal voltage at fixed frequency and constant amplitude is “rectified” into a DC-voltage or DC-current. This DC-quantity is then, in a second step, “inverted” into an AC-voltage or current whose frequency and amplitude are variable. Both the rectifier part and the inverter part of this conversion are realized by electronic circuits built up of electronic switches. This article is primarily about the

2 Phase representation of a two-level voltage source inverter by means of an ideal switch, fed by a DC-voltage source

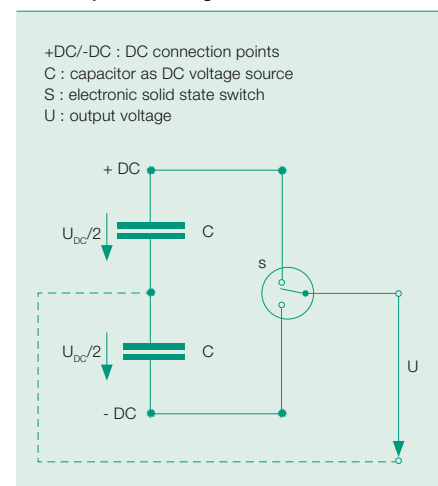

Footnote

¹⁾ See also Wikstroem, P., Tolvanen, J., Savolainen, A., Barbosa, P., Saving energy through drive efficiency, ABB Review 2/2007, 73–80 (especially pages 74–76).

Product innovations

3 Two-level inverter with split capacitor **a** and three-level inverter **b** (conceptual drawings)

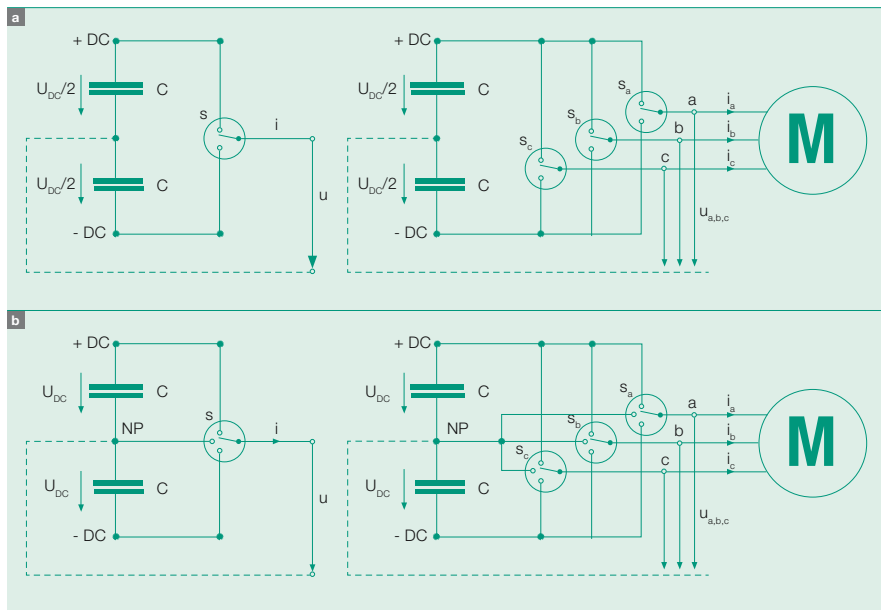

4 Although the switches in converters are often represented as simple contacts (left), they do in fact integrate a larger number of semiconductor components (right). **a** shows a two-level phase leg and **b** its three-level equivalent

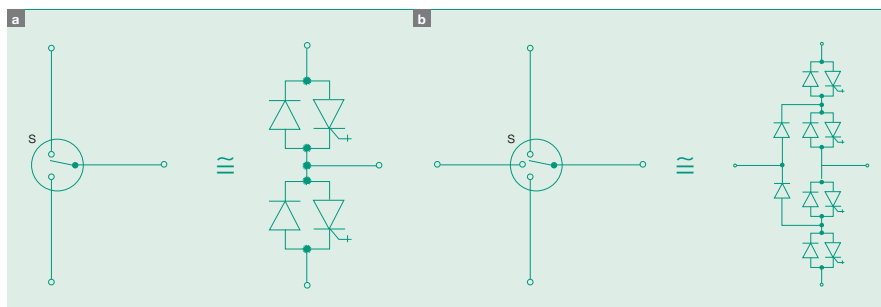

Factbox 1 Semiconductors: 50 years of development in switching

In the past 50 years, ABB has established and maintained a leading position in the field of power electronics. Frequency converters for motors are an essential part of this business.

Electronic switches are at the heart of every frequency converter. The story of the emergence of five-level switching, is best introduced by a brief tour of the evolution of these devices.

Readers who have been following the development of these devices long enough will remember that the first high-power electric drives were based on line-commutated thyristors. These thyristors can be designed for high currents and high blocking-voltages (present-day versions reach values of

8–10 kV). Their major drawback is that they can be switched on at any given point but cannot be switched off (they remain on until an external effect causes the current to stop flowing). This feature limits the available switching strategies, and by consequence the suitability of such circuits from a power quality point of view (see two-level switching in **7a**).

Converters using these switches create harmonics of high magnitude and relatively low frequency. Such harmonics cause problems both on the supply and the motor side. Moreover, the power factor on the network side varies over the operating range of the frequency converter. Line side problems have been addressed by using filters. The motor side problems are dealt with by dimensioning the motor to cope with the additional heating and to

technology of this second step, the inverter.

Most ABB converters are so-called Voltage Source Inverters (VSIs). **2** shows the simplest topology of a VSI: A single output phase of the frequency inverter is alternatively connected to one or the other pole of a large DC-capacitor. It is the purpose of the rectifier circuit (not shown) to ensure that this capacitor is kept charged to a fixed DC-voltage. If an AC-voltage is to be generated, the switch in the inverter circuit needs to change positions (ie, change the output voltage) at least once every half cycle. If an output of 50 Hz is required, for example, the switch should change to each of its two positions at least 50 times per second.

In practice, the switch is usually “flipped” much faster than this. A digital controller is used to direct its switching status. The switching strategy of this controller determines not only the frequency but also the average voltage across the load. These levels are modified by adjusting the input values of this unit as desired. This control strategy is known as Pulse Width Modulation (PWM).

In reality, the switch is not a moving contact as the diagrams suggest, but is

built up from power semiconductor devices [4a](#). The development and capabilities of such switches has, since the first emergence of such converters, been dependent on progress in power semiconductors

Factbox 1.

Ready for the next level

Although the two-level VSI voltage waveform as shown in [7a](#) can be varied in amplitude and frequency by means of PWM, the shape of the output is far from sinusoidal. As a result, the harmonic current distortion, and hence additional losses and the resulting heat generation in the motor, are high. One way to render the voltage waveform more desirable is to introduce more voltage levels. To introduce another simple analogy, this is similar to increasing the resolution on a computer monitor to make the graphics sharper.

ABB's ACS 5000 converter uses five-level technology

A further reason for wishing to move away from the two-level arrangement is that the highest output voltage that can be achieved with the two-level

VSI topology and modern power semiconductors is 2.3 kV. This is not enough for the standard range of medium voltage motors.

The topology with two capacitors and an electronic three-position switch, which is also referred to as the three-level inverter because of the number of output voltage combinations per

5 Concept of the new innovative five-level inverter phase (left) and the complete three-phase motor drive with nine-level phase-to-phase voltage

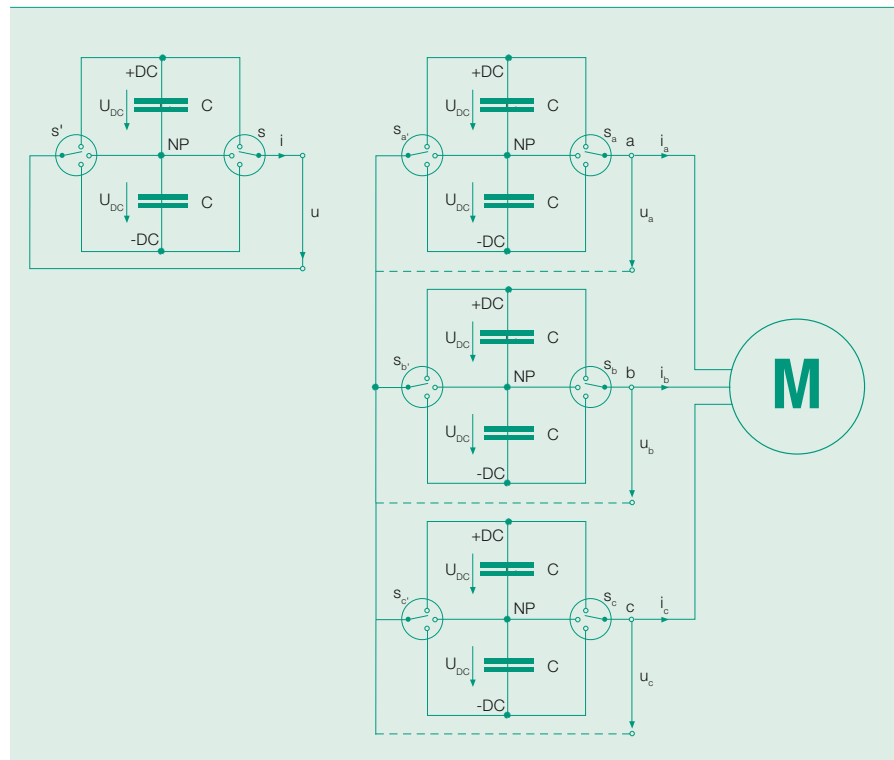

6 ABB's ACS 5000 converter uses five-level technology, delivering a nine-level phase-to-phase voltage to the motor



Product innovations

phase, has been known for some time. **3b** shows a conceptual schematic with a three-position switch. This circuit has to switch any of the three connection points of the capacitors to the output for both current directions²⁾. For specific voltage and current ratings, ABB has standardized this electronic three-position switch **4b** as a Power Electronic Building Block (PEBB). This standardization provides the advantage that the same building blocks are used in different applications, permitting ABB to collect field experience much more quickly and so fine-tune the design, providing higher reliability for the customer.

Increasing the number of levels drastically improves the waveform.

For about a decade, these building blocks have been used for different products and systems, including converters for variable speed drives (eg, in the ACS 1000 and ACS 6000 drive units), energy storage systems and power quality systems.

The five-level evolution

Combinations of a higher number of capacitors and increasingly complex electronic circuits have been discussed in academia for some time. Usually, however, such suggestions did not fit established technologies for capacitor energy storage, nor were they compatible with the properties of the semiconductor switches the market had to offer. Furthermore, such

Factbox ABB drives product range

ABB, as the leading supplier of drives, offers the complete range of variable speed drives for applications in the power range of 0.12kW to over 100MW.

The company serves utilities and industrial customers in the cement, mining & minerals, chemical, oil & gas, marine, metals and pulp & paper industries.

For further information, visit www.abb.com/drives

7 Increasing the number of levels from two **a**, through three **b** to five **c** drastically improves the waveform, even for the minimal switching frequency as shown

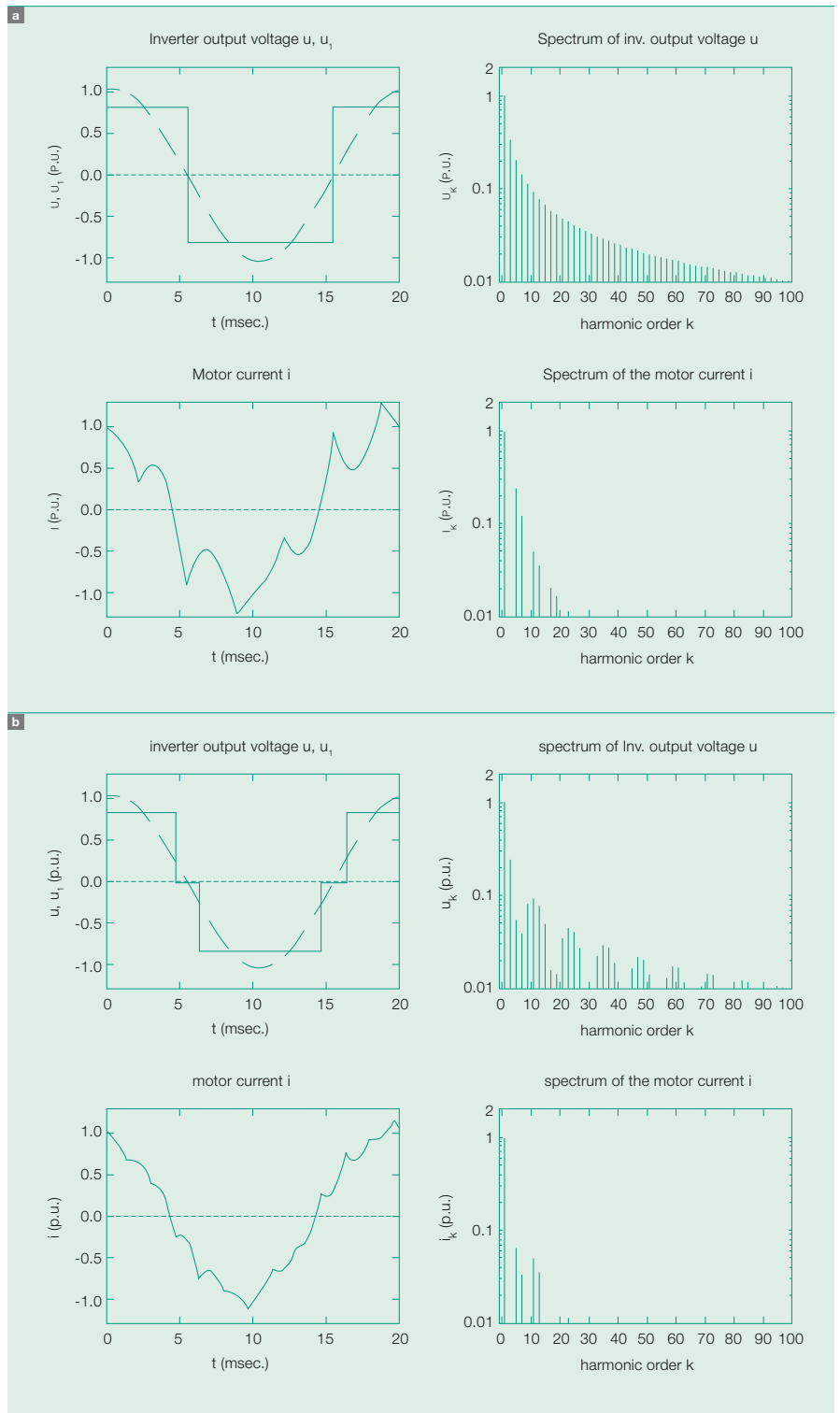

solutions allowed little re-use of existing building blocks, and their reliability figures were questionable due to a high parts count.

For the latest addition to its family of medium voltage drives, the ACS 5000,

ABB engineers looked back at traditional thyristor-based products such as cycloconverters and – with the available three-level building block of **4b** in mind – came up with an astonishingly simple solution for a product with five output voltage levels (and

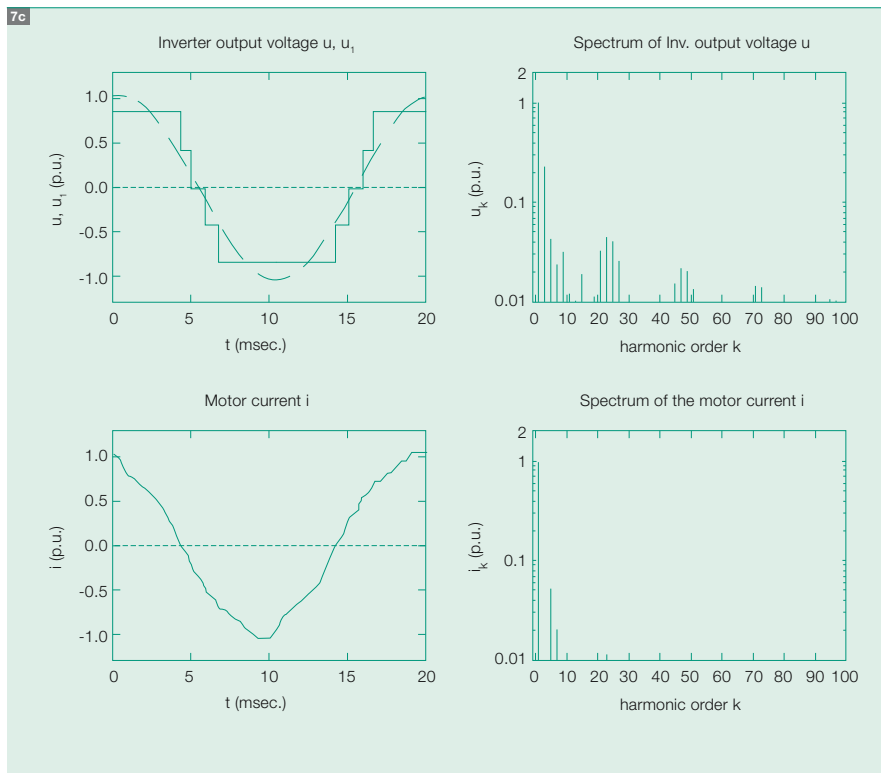

A 5-level power electronic building block easily slides into the drive on rails



hence nine levels phase-to-phase) **8**. This was achieved by applying the proven three-level technology in relation to the star point of the electrical system independently for each phase.

The conceptual circuit **5** is derived from identical existing building blocks S and S' respectively.

The well-established technology of the three-level inverter is re-used in an innovative configuration.

Why five levels?

The phase-to-phase voltage waveform of a two-level inverter and a three-level inverter are compared with that of the new five-level converter **7c**. The five-level inverter used in the ACS 5000 **6** delivers a nine-level phase-to-phase voltage to the motor **8**. Just from looking at the waveform, it already becomes obvious that the new five-level inverter produces an output that is much closer to the ideal sine wave. In fact, the result is so convincing that it is

now possible to use motors designed for direct-on-line connection without needing to de-rate them. This presents the optimal solution for a 6 kV converter today.

Would adding further switching levels be a goal to further improve waveforms? Such attempts would significantly add to complexity without delivering proportional benefits. In particular, the reliability of the drive would get worse due to the higher parts count.

Proven solutions

ABB has found a surprisingly simple way of creating near-sinusoidal volt-

age waveforms with a frequency converter largely based on proven, existing components. The well established technology of the three-level inverter is re-used in an innovative configuration, providing five-voltage levels per phase, or even nine-voltage levels phase-to-phase. The full re-use of basic power electronic building blocks allows these excellent output waveforms to be achieved with proven reliability. The goal to use standard motors is reached while maintaining high efficiency with a low parts count.

8 Using a five-level converter, the output voltage reaches nine levels phase-to-phase

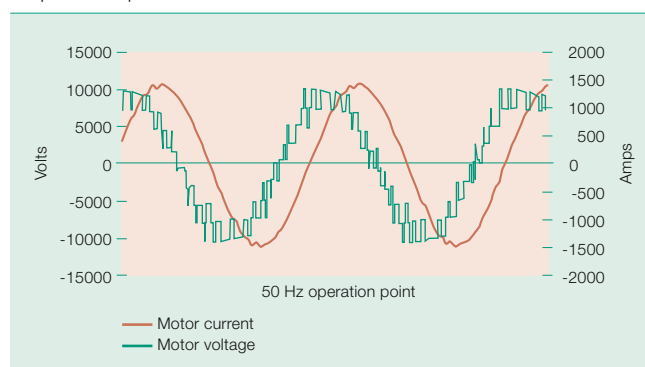

Pieder Jörg
Gerald Scheuer
Per Wikström
 ABB Switzerland Ltd.
 Turgi, Switzerland
 pieder.joerg@ch.abb.com
 gerald.scheuer@ch.abb.com
 per.wikstroem@ch.abb.com

Footnote

²⁾ Most high-power semiconductor devices can conduct current in only one direction.



Integration breakthrough

Creating a flexible and compact DC breaker: the ABB SACE Emax DC
Giovanni Frassinetti

Wiring is the Achilles heel of many an installation. It costs time and money to wire a new item into the setup, and more time and money to test and verify it. In addition, the assorted connected items all occupy space – a scarce asset in many plants – and each require a power supply. The answer lies in integration; combining as much functionality as possible into a single piece of off-the-shelf equipment. In the field of

DC breakers, ABB has achieved a hitherto unseen level of integration.

With its ABB SACE Emax DC breaker, the company has succeeded in integrating a broad range of advanced monitoring, protection and control functions in an application that was previously reliant on external devices. The result is the most innovative and complete air-insulated DC circuit

breaker range on the market – a breaker that can stand as a reference product for any kind of DC application.

In this article, ABB Review looks at some of the challenges that were faced in creating this project, and takes a more detailed and technical look at some of the technologies applied.

Examples of applications for DC current breakers include so called “critical power” applications, ie, situations in which the continuity of the power supply is of fundamental importance. Examples are hospitals, continuous process industries, emergency and safety plants, telecommunications and data-processing centers. These are applications in which an immediately available back-up energy source is essential. In this domain, battery packs represent a highly reliable and quickly deployable option.

Further examples of DC applications are electrical traction and drilling, chemical and electrolytic process industries and naval applications (speed control and battery or fuel cell propulsion).

Breakers in these applications must protect and disconnect both supplies and loads while assuring the integrity of the power supply. ABB SACE Emax DC, which is presented in this article, is not only perfectly suited to such applications, providing a complete and fully-integrated solution for high-level DC applications, but is also unique: No other product on the market offers such characteristics

Factbox

Applications

Present applications of DC breakers can be divided into two types, according to the source of the trigger signal for the interruption of the current:

- Automatic breakers triggered by an internal electromechanical mechanism
- Externally triggered switch-disconnectors

Automatic breakers with integrated electromechanical releases offer a solution for low-end applications working in self-supply mode. Such breakers provide only instantaneous short-circuit protection. No other standard or advanced protection, mea-

surement, communication, automation, diagnostic or HMI functions are included.

Breakers in DC applications must protect and disconnect both supplies and loads while assuring the integrity of the power supply.

Switch-disconnectors used in combination with external electronic releases can offer a broad range of standard protection functions (mainly overload

and selective/instantaneous short-circuit) but they cannot meet other very important requirements. As they are not an integrated solution, the customer must install the trip unit and current sensors in the switchboard. This means that the switchboard's dimensions cannot be as compact as they are in the case of an automatic breaker.

Furthermore, the need to connect, wire and test the external release system implies additional engineering and installation costs (such system testing and certification is the responsibility of the panel builder/system integrator). In addition to this, an auxiliary power supply must be provided for the trip unit and the actuator.

A further disadvantage of the externally triggered variant is that the maximum breaking capacity of such a breaker is defined by the short-time current-withstand value of the switch-disconnector. This figure is typically lower than the short-circuit breaking capacity of an automatic breaker, due to the lower reaction delay of the integrated unit.

The ABB SACE Emax DC **1** series offers an innovative solution that includes all the advantages of the integrated solution, while adding several interesting and important features.

This makes it a market reference product for any kind of DC application. This success was achieved through innovatively re-interpreting conventional products to provide new solutions.

Product architecture

Integrated AC breakers have been on the market for many years. The approaches adopted, however, could not directly be transferred to the DC version. A whole range of aspects had to be fundamentally redesigned.

1 Control panel of the ABB SACE Emax DC circuit breaker



2 Product architecture of the circuit breaker

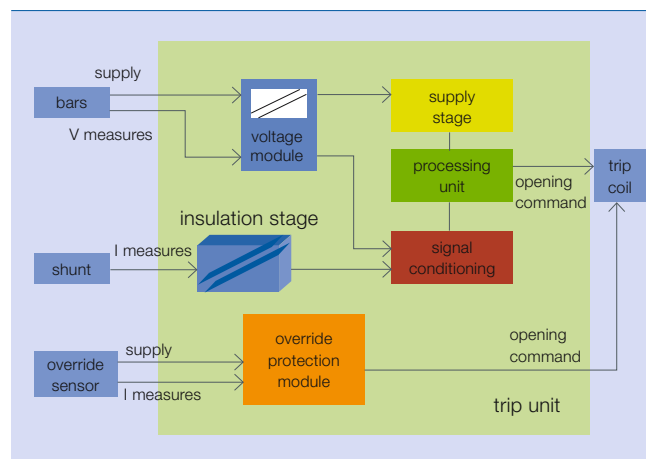

3 Trip unit

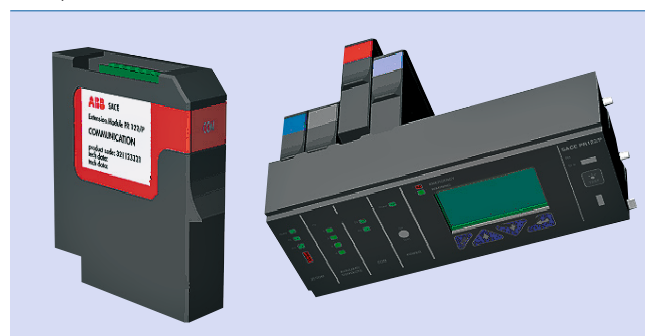

Product innovations

The system architecture of the new DC breaker **2** comprises:

- A shunt for current measurement and protection
- An override sensor for instantaneous back-up protection
- An electronic trip unit
- An actuator to open the breaker (trip coil).

The trip unit uses the same architecture as the present Emax AC series. The hardware has been enhanced to meet the DC unit's higher insulation and lower signal processing requirements. The software has been modified to measure direct current (mean value instead of RMS) and to adapt the protection algorithms to the new measuring method.

The trip unit **3** itself is equipped with optional modules to add functionalities. Examples of these are:

- A communication module providing a galvanically insulated interface to a supervisor system.

4 The shunt used by the circuit breaker to measure current

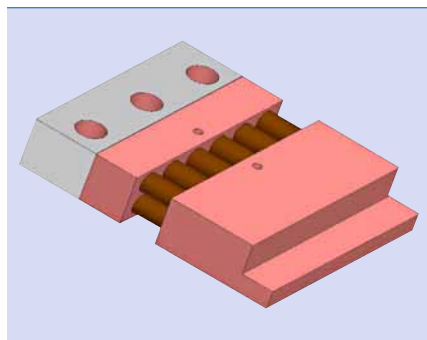

- A signalling module equipped with contacts that can be used to drive external devices. It can also be configured as an input.

The electronic trip unit is powered from the breaker's main terminals via an integrated "voltage module," the integrated override sensor (override protection module) or an external insulated power supply (24 Vdc). The voltage module also provides the voltage measurements that the trip unit requires for further signal analysis, such as power measurements, and to perform overvoltage, undervoltage and reverse power protection functions.

The ABB SACE Emax DC series offers an innovative solution that includes all the advantages of the integrated solution, while adding several interesting and important features.

The integration of all these components makes this breaker one of the most significant electronic embedded systems in the field of Air Circuit Breaker (ACBs). Its capabilities border on those of the concept of a "mechanronic system."

Shunt

The shunt is the current sensor¹⁾. It provides a voltage signal proportional to the current. The output signal of

this unit must range between 2.56 mV and 240 mV.

The challenge in designing the shunt **4** was to define a device compact enough to be installed inside the breaker. Furthermore, it should have a resistance high enough to drive the electronics of the TU (Trip Unit) but low enough to permit a power dissipation compatible with the breaker's plastic support – and this both at rated current and under short-circuit conditions (100 kA for 0.5 sec).

The minimum resistance that, at rated current, gives an output with a signal/noise ratio consistent with the specifications of the TU is 8 μΩ at 1600 A. To obtain the required functionality at rated current, the shunt temperature was kept as low as possible by increasing the thermal conductance **Equation 1**. For this purpose, a detailed thermal flux assessment was performed using FEM (Finite Element Method) analysis **5**, permitting the resulting temperature rise on the plastic shunt support to be limited to the required value.

$$\text{Equation 1 } \theta_s = \frac{P_p}{G}$$

where:

P_p: power loss

G: thermal conductance

θ_s: steady temperature rise

Footnote

¹⁾ In AC breakers, a current transformer is normally used. The DC version requires a different approach.

5 Current density **a** and thermal flux **b** in the shunt at rated current

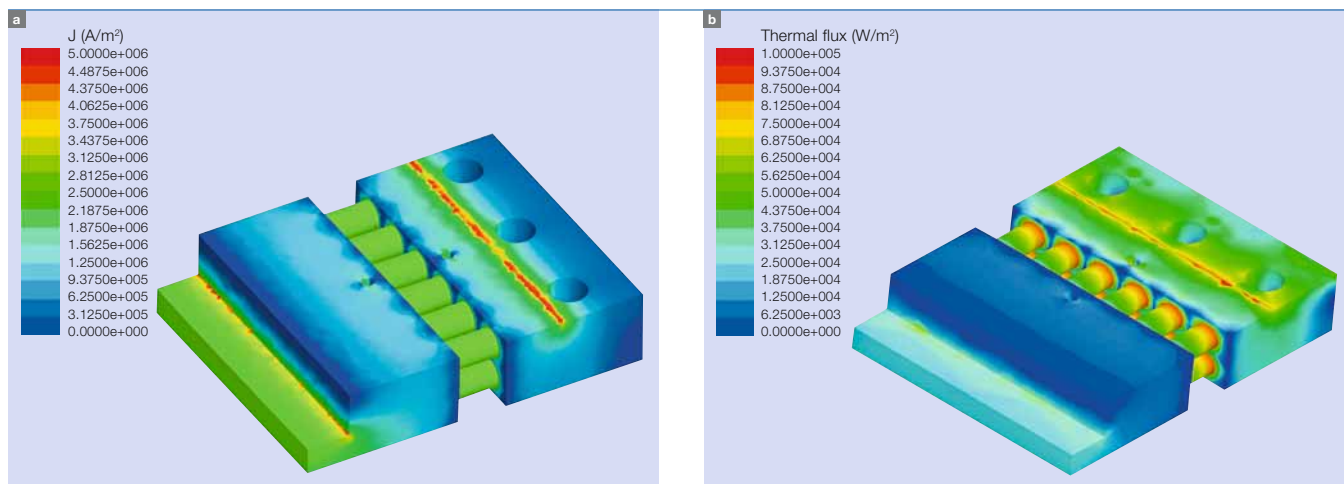

To permit the shunt to perform correctly under short-circuit conditions (100kA for 0.5 sec), the only way to control the temperature is to increase the thermal capacity – because the phenomenon can be seen as adiabatic **Equation 2**.

Equation 2
$$\theta_{ad} = \frac{R \cdot I^2 t}{C}$$

where:
 $I^2 t$: let-through energy
 θ_{ad} : adiabatic temperature rise
 R : shunt resistance
 C : thermal capacity

Equation 3
$$C = m \cdot c$$

where
 m : mass
 c : specific heat

To ensure functionality under overload conditions, the designers maximized the thermal time-constant of the shunts in order to increase their overload performance (ie, to reduce the temperature rise of the shunt during overloading). This was accomplished by optimizing the shape of the shunt-terminal assembly - that is, by increasing the mass without reducing the thermal conductivity

Equations 4-5

The thermal transients for two different solutions are shown in **6**: For the same resistance, the red curve

6 Transient shunt temperature rise with different thermal time constants at an overload six times the rated current, $6I_n$ ($\tau_2 > \tau_1$)

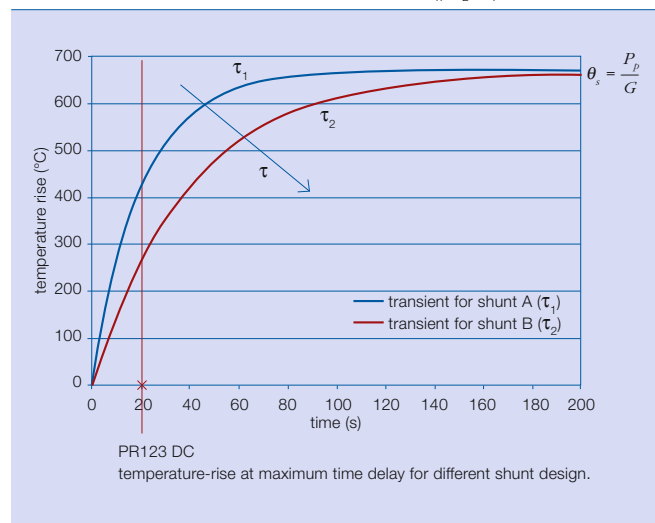

(higher time constant) coincides with a 30 percent lower temperature increase before the breaker is tripped after a 20-second overload.

Equation 4
$$\tau = \frac{C}{G}$$

Equation 5
$$\theta(t) = \theta_s \cdot \left\{ 1 - e^{-\frac{t}{\tau}} \right\}$$

where:
 τ : thermal time constant
 θ : temperature rise

Insulation

Because shunts are used, the electronic trip unit is not galvanically separated from the main live bars. A major challenge encountered con-

cerned how to guarantee the adequate insulation level. According to the IEC 60947-1 product standard, a rated impulse withstand voltage of 14.4 kV is required without the electronic trip unit having to be withdrawn from the CB frame as a result. This is made more tricky by the fact that the electronic trip unit is connected directly to the power bars, without any type of insulation or segregation (as in the situation when current transformers are used as in the AC breaker): This problem was solved by introducing insulated operational amplifiers (one for each shunt sensor).

Signal conditioning

To guarantee the maximum measurement accuracy over a wide range of currents by exploiting the maximum dynamics of the AD converter, the signals coming from different shunt sensors are scaled using an analog circuit.

Voltage module

The voltage module provides the energy for supplying the trip unit and also supplies a voltage signal that is proportional to the primary voltage. This is used for its measurement (with high-impedance insulation).

Supply stage

The supply stage handles the supply coming from the two possible sources

7 Mesh calculation with FEM (Finite Element Method) and output simulations

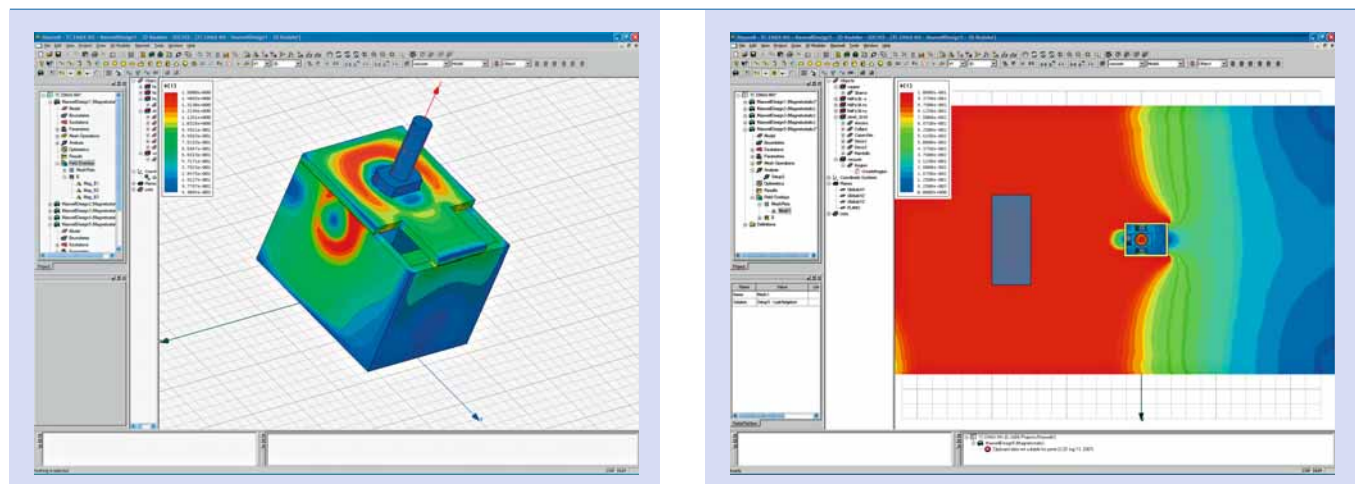

Product innovations

(an insulated power supply from an optional external source or the bar voltage) and delivers the energy to each part of the electronic system at the required voltage levels.

Processing unit

The processing uses a parallel architecture with three processors: a low-power processor for handling start-up

and very fast protection functions, a DSP (Digital Signal Processor) for all other functionalities, and another low-power processor containing information about the current breaker (CB) in which the electronic unit is installed. Due to the very low resistance of the shunt's sensors, the source signal is very weak. Consequently, the means of measurement must be adapted to

such a signal. The signal is amplified and scaled to make it proportional to the CB's rated current (I_n). To guarantee better measurements, two scales are provided, one from 0 to $4I_n$ and the other from 4 to $12I_n$. The signal dynamic is quite significant: about 50 dB.

The electronic system could be made highly sensitive to low signals, while at the same time remaining immune to high external disturbances and short-circuit currents through the choice of high-performance components and a very accurate PCB layout.

The software was created using the UML method and written in C language. It is fully modular and developed according to best software engineering practices and internal software quality procedures.

ABB SACE Emax DC is the only breaker of its type on the market, set apart by a unique mix of features and characteristics.

Trip coil

The current breaker is opened by an electromagnetic actuator. It is controlled by the electronic trip unit and the self-supply override protection unit with two independent and parallel channels.

A typical contradiction in CB design lies in designing an actuator that is small, cost-effective, energy-efficient

Factbox A unique solution

ABB SACE Emax DC is the only breaker of its type on the market. It is set apart by a unique mix of features and characteristics:

- Wide range of protection functions and relevant settings taking full advantage of an electronic trip unit with standard features (overload, selective and instantaneous short-circuit) and advanced features under- and over-voltage, polarity unbalance, reverse power flow, zone selectivity and thermal memory). Both polarities are protected so as to detect and extinguish all possible types of fault whatever the type of distribution system.
- No need for an auxiliary power supply: all protection and measurement functions are performed in self-supply mode by means of the voltage module.
- Full integration: The trip unit, current and voltage sensors and connections are completely integrated in the breaker. The breaker is officially certified and compliant with the main shipping registers and every unit tested at production facilities.
- High electrical performance: rated currents from 800A up to 5000A, operating voltages up to 1000V, rated short-circuit levels up to 100kA and rated short-time withstand current up to 100kA.

- A complete set of measurements: currents, voltages, power, energy counter.
- A wide range of communication and automation functions: communication module with the Modbus RTU protocol and, thanks to the FieldBusPlug^{*)} system, Profibus and Devicenet, Bluetooth connectivity for local configuration, programmable contacts for warning and alarm indications and load control function.
- Advanced HMI and diagnostic information: graphic display, trip indicators, continuous checking of wiring integrity, hand-portable test unit, data recording for the most recent 20 trips and 80 events, and a data logger function (recording all measurements at a sampling frequency of up to 4800Hz for 27 seconds and with a configurable trigger).

These features combine to make ABB's SACE Emax DC the reference ACB for DC applications: No other product currently on the market achieves such a performance.

Footnote

^{*)} FieldBusPlug is an ABB technology permitting the same devices to be connected to different fieldbus types by integrating the connectivity in the plug.

8 Internal view of override current sensor

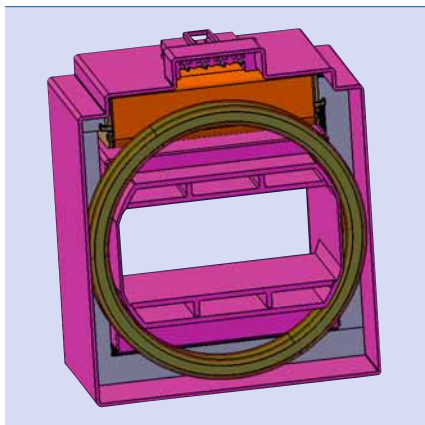

9 Self-supply override protection module

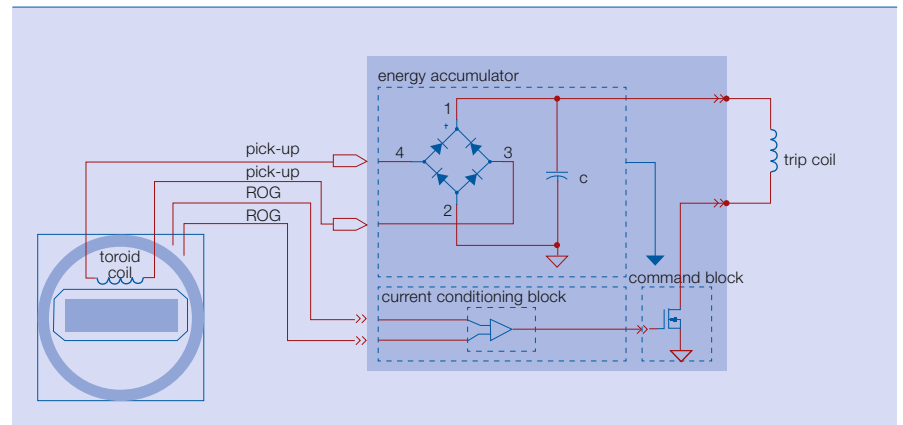

and high performance, while is at the same time being able to avoid any spurious tripping by shielding against the very high electromagnetic fields generated by the short-circuit currents flowing in the power bar. The correct dimensioning of the actuator was achieved by means of a magnetic field FEM analysis **7**.

Override current sensors

The purpose of override current sensors is to provide an output signal in the event of a transient short-circuit. Such a condition arises when a breaker that was previously closed on a short-circuited line is energized by an upstream circuit breaker.

With this solution, customers can avoid having to combine different components.

The sensor is made in two parts: a current transformer for supplying the electronic module and the trip coil and a Rogowski coil for providing the signal to be measured. The sensors can guarantee the required level of accuracy over the whole range of currents. They also guarantee the right insulation level between primary bars and the secondary system **8**.

Self-supply override protection module

This is an analog electronic module designed to guarantee instantaneous protection whatever the supply conditions. The challenge was to assure protection even in the absence of an external power supply and bar voltage. A dedicated module **9** (the override protection module) was developed to go into action whenever the electronic trip unit is off.

The unit is powered by a current transformer energized by a DC current gradient during a short-circuit. The current is measured by a Rogowski coil. This provides an output proportional to the derivative of the current. The conditioning block receives the signal from the coil and processes it through an analog filter (or integrator) to reconstruct the primary signal. This output is compared with a threshold set by means of dip switches and if

10 Simulation using a primary current with a 2 ms time constant coming from a rectifier bridge **a**, recorded during a test and the filter output after integration **b**

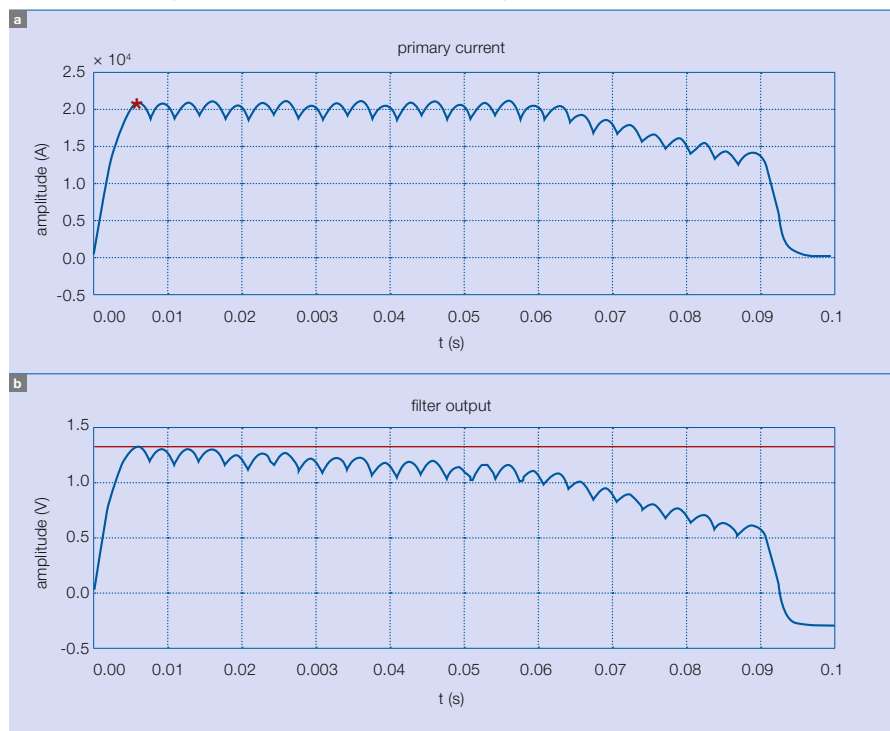

this threshold is exceeded, an opening command is sent to the trip coil.

A simulation using a primary current is shown in **10a**. This example, recorded during a test, features a 2 ms time constant coming from a rectifier bridge. The corresponding filter output after integration is shown in **10b**.

A highly successful development

The success with which all the challenges of the project were met led to the development of an innovative, compact product that provides the solution to all possible protection and control needs in DC systems.

A vast range of protection, measurement and interfacing functions provides better control.

With this solution, customers can avoid having to combine different components and can rely on an integrated product that has been tested and certified by the manufacturer. There are also significant advantages in terms of a reduced overall size of

the installation by comparison with the solutions with outside sensors and relays, and a reduction in engineering requirements for the customer.

The availability of a vast range of protection, measurement and interfacing functions provides customers with the means to better control and protect their electric systems.

Giovanni Frassinetti
ABB SACE S.P.A.
Bergamo, Italy
giovanni.frassinetti@it.abb.com

Speed and quality

Shifting into high gear with IEC 61850-based substation automation engineering
Christian Frei, Hubert Kirmann, Tatjana Kostic, Tetsuji Maeda, Michael Obrist

The publication of the international standard IEC 61850 for the automation of substations effective since 2005 is considered a breakthrough in electrical power technology by the protection and substation automation community. This big step was the result of the application of state-of-the-art information and communication technology to a field that tradi-

tionally just transmitted bits and bytes over wires.

Once the transition to information and communication technology was made, a whole world of new opportunities opened up to improve the complex task of substation automation system engineering. ABB has taken the next step, developing a powerful

engineering environment for substation automation, from automation system specification to system testing. Using this extensive toolbox, ABB is delivering thoroughly tested SA systems and is providing smooth operation at customer sites when rebuilding or maintenance is required.



Substations are important nodes in a transmission and distribution grid. Within substations, the electric power is transformed to the appropriate voltage level – high voltage for transmission, medium voltage for distribution. The transformation is made by power transformers, which can take the size of a residential house. Along with the transformation, the electric power flow has to be switched on and off by circuit breakers to feed the required lines. Circuit breakers can, under the control of protection devices, interrupt very high currents in a few milliseconds in an emergency; ie, they can isolate faults in switch yard equipment and lines, thus preventing their effect(s) from spreading throughout the whole network. Substations are also equipped with various measuring devices to record the actual current and voltage of the lines, as well as the power flow.

Modern switchgear is equipped with a number of sensors and electronics to acquire the huge amount of information. An example of such an intelligent device is the hybrid switchgear **1**, integrating powerful circuit breakers, disconnectors and protection and measuring units into one component. The internal control electronics to read the sensors and trigger the actuators can communicate the data and analyze them to give real-time status information.

For the operator of a grid, which may span a whole country and feeds power to numerous areas, the substations are the control points for the flow and the stability of the grid. Substations thus must guarantee reliable and safe operations.

In view of these quality and safety requirements, engineers who design, build and test a substation must apply the utmost diligence. Besides the proper physical operation of all the devices in the setup, the substation automation system that controls the real-time response of the substation must be able to cope with any possible situations occurring in a complex electrical grid.

Paradigm shift

Decades ago, the main goal of substation engineers was to develop reliable components like transformers or circuit breakers and connect them in a simple way to fulfill the requirements of a substation. The signals necessary for controlling the substation operations were transmitted with low bandwidth via direct cable connections. Engineers designed the control systems so that the number of bytes to be transmitted for a reliable operation was as small as possible. The protocols required for data communication were designed to cope with this severe bandwidth limitation. Later on, when more powerful communication technology like Ethernet and networking protocols such as TCP/IP became widespread, the traditional protocols were adapted to run over TCP/IP-Ethernet.

Modern switchgear is equipped with a number of sensors and electronics to acquire the huge amount of information.

Although the use of Ethernet and TCP/IP offered more possibilities for substation control, it was a halfhearted approach, as it supported the very same basic electric power system capabilities as the serial link version, but not more than that. Engineers continued to use the same protocols

previously designed for minimizing the bytes on wires and did not take advantage of the huge additional possibilities offered by modern information technology concepts.

When it became clear that further significant progress should come from more versatile applications the IED Technical Committee TC57 – designed a new protocol for substation automation, effective since 2005 as the IEC 61850 standard [1]. Within a very short time, IEC 61850 became the global standard for power utility automation, and today customers request that suppliers follow this standard for almost every new substation built worldwide.

The major step behind this standard is the consequent application of concepts of modern information and communication technology, making IEC 61850 the trendsetter for other automation areas [2]. With this approach, the physical objects in a substation can be described by a set of aspects such as their position in the substation, their main purpose, their physical status and their control requirements.

Giving standardized names to all the components (called logical nodes in the abstract presentation of the substation) and their various aspects provides a setup that is neutral with regard to the specific supplier of the equipment. The standard also describes the way logical nodes communicate with each other and with

higher control systems within the substation or with any external control system.

Intelligent devices

To make full use of the possibilities of the powerful communication systems, the devices in a substation must be able to communicate and provide a broad set of data. This requirement is also reflected in their IEC 61850 name – Intelligent Electronic Devices (IEDs). IEDs host logical nodes, which represent a typical function part, which, for instance, can abstract some physical equip-

1 ABB'S compact Pass MO 170kV hybrid switchgear combines various functions



Process innovations

ment, expose control means over such equipment or represent a protection function.

Take for example a circuit breaker. The standard defines a specific logical node to identify a circuit breaker within the network, and, as a container for the information about its switch position (open, closed), the number of operations, the accumulated switched amperes, the remaining operating capability or the status of its drive mechanism, to mention a few. The communication with the IED

through IEC 61850 allows the substation automation system to automatically identify the device when it is plugged in. "Plug-and-operate" is a feature known to every PC user, when an external device is connected. Plug-and-operate facilitates the installation of a substation [3].

Mastering the information and data flow

With all the boundary conditions of the IEC 61850 provided, it is the task of the engineer to master the enormous amount of data that describe

and control the operation of a substation [2]. This task already starts in the specification phase of a new substation when the overall model of the substation is defined and tuned to the specific needs of the customer. The next step is the detailed specification of bay¹⁾ functionality and needed signals, followed by the engineering phase, in which all elements of the automation system must be realized. Before any onsite operation can be carried out, the whole system must be thoroughly tested, which is done in the factories as well as onsite.

2 Engineering phases of the design of a substation automation system



ABB made great progress in this direction and is now able to use a full-fledged engineering environment for substation automation from the specification to the site acceptance test.

New opportunities for customers

The IEC 61850 standard has been designed to give engineers the opportunity to realize all the features described above. But the way forward from a mere opportunity to a real tool that makes efficient use of these possibilities is a big challenge for engineers – many technical hurdles must be overcome by employing the creativity of information technology experts. ABB made great progress in this direction and is now able to use a full-fledged engineering environment for substation automation from the specification to the site acceptance test. This engineering environment not only supports the design process but also offers additional value when existing substations must be refurbished or extended and when the older parts of the setup do not comply with the new IEC 61850 standard.

3 Main elements of a substation automation system

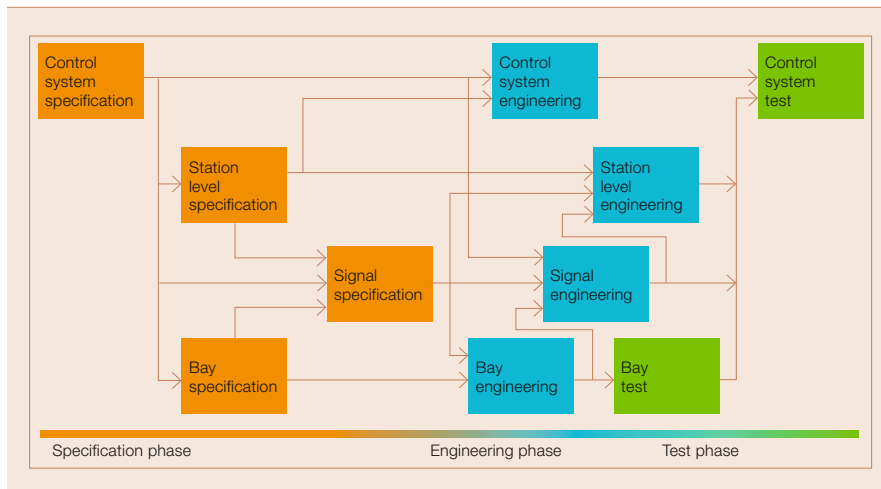
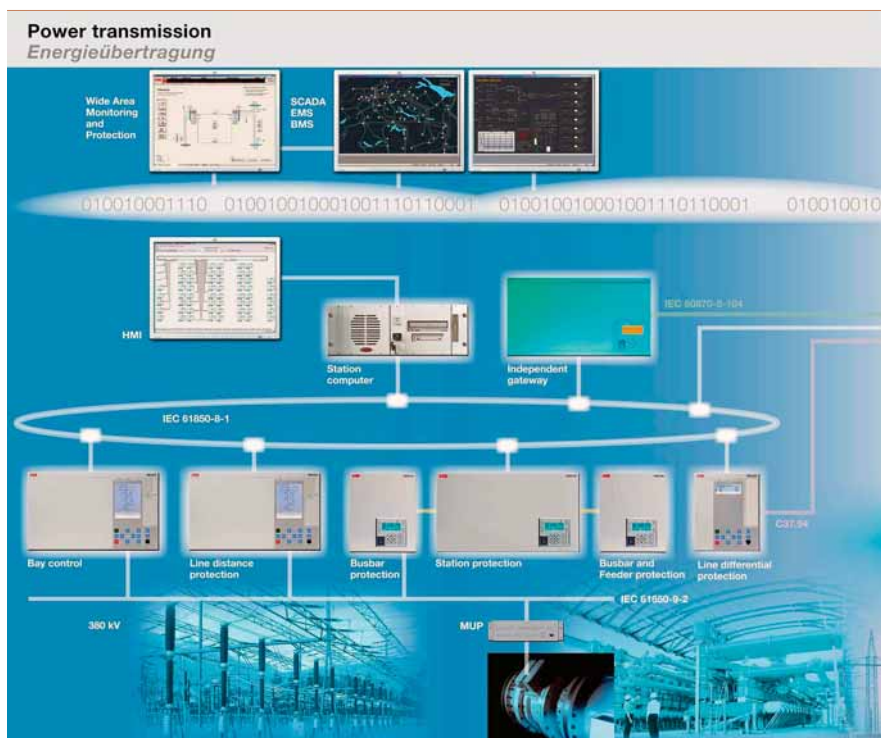

The innovative steps that were taken are an almost classic example of the process of innovation as such -methods and tools developed in software engineering, like the automated testing of codes and consistency checks of architectures, are consequently

applied in the traditional field of substation automation, a typical approach for cross fertilization of technology. Following are just a few examples that demonstrate the powerful applications of system testing tools based on IEC 61850 modeling concepts.

8 shows the main elements of a substation automation system designed according to the IEC 61850 standard. On the bay level, IEDs can communicate sampled values of voltages and currents via appropriate periodic communication services; the different bays then exchange data on events, defined by the GOOSE²⁾ service, typically via a station bus. This bus, which makes the physical connection to the supervisory level, also transports the vertical communication to station-level devices and network control centers using the MMS protocol³⁾.

With the definitions given in the IEC 61850 standard, a virtual model of the substation can be generated, mapping all features of the IEDs and the communication channels. In the design process of a new substation, the engineers design the substation automation system, which can be loaded into the new testing tool to set up the virtual model of the substation from the very beginning. The testing tool can also generate this virtual model when connected to an existing substation, provided it is configured according the IEC 61850 standard. This step assures the necessary completeness and consistency, and no further examination via the SAS⁵⁾ system is required.

The SAS system itself can be tested in a similar way when connected to the tool. The tool checks for the proper definition of names or the configuration of reports and events, for example, and simulates all the devices in the substation to be addressed by SAS. This offers the huge advantage of being able to run tests already in an office environment rather than in the field.

4 directly illustrates the paradigm shift in testing when the new IEC 61850 tool environment is used. While in the traditional approach, the devices had to be physically present and connect-

4 Significant simplification of testing with the new IEC 61850 tool environment

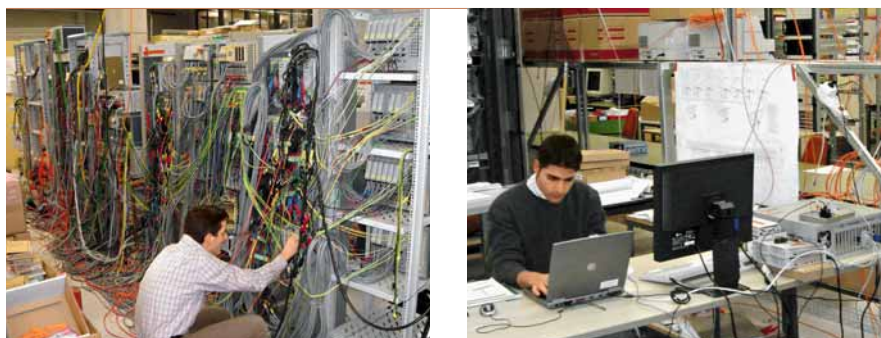

ed to the SAS, the new tool simulates the IEDs, which are pre-checked for their consistency, and allows for fast and efficient tests in an office environment.

The alternate method is possible as well. If real IEDs are available without a SAS installed, the IEDs can be connected to the tool that in this case will simulate the missing SAS.

The examples given demonstrate the versatility of this unique engineering tool now available to ABB engineers.

Of course, the GOOSE traffic also can be tested for proper operation with the new program. When real IEDs, possibly combined with simulated IEDs, are checked for their response to the interlocking logic, any flaws in the substation automation system can easily be detected. Various test cycles, examining the full spectrum of possible real cases, can thus be executed in a short time.

Customer benefits

The examples given demonstrate the versatility of this unique engineering tool now available to ABB engineers.

It facilitates up engineering and testing processes, allowing fast delivery of SA systems to customers. It significantly increases the reliability and plug-and-operate performance of substations, short-cutting commissioning phases with carefully pre-tested systems. It also shortens outage times at the customer site in cases of refurbish-

ment or maintenance due to the manifold possibilities of testing within the virtual engineering environment. The development of such a powerful engineering tool is a model case for a process innovation providing significant value for ABB and its customers.

Christian Frei

Hubert Kirmann

Tatjana Kostic

ABB Corporate Research
Baden-Dättwil, Switzerland
christian.frei@ch.abb.com
hubert.kirmann@ch.abb.com
tatjana.kostic@ch.abb.com

Tetsuji Maeda

Michael Obrist

Power Systems
ABB Switzerland
Baden, Switzerland
tetsuji.maeda@ch.abb.com
michael.obrist@ch.abb.com

Footnotes

- ¹⁾ A bay is the group of devices required to supervise, control and protect a line in the grid.
- ²⁾ GOOSE: Generic Object-Oriented Substation Event.
- ³⁾ MMS: Manufacturing Message Specification. This ISO protocol originally designed for a manufacturing environment has been chosen for IEC 61850 as the most appropriate existing standard for this type of information flow.
- ⁴⁾ SCADA: Supervisory Control and Data Acquisition.
- ⁵⁾ SAS: Substation Automation System

References

- [1] IEC 61850: Communications, networks and systems in substations, International Standard, 2003.
- [2] Kostic, T., Preiss, O., Frei, C. (2005). Understanding and using the IEC 61850: a case for meta-modelling. *Elsevier Journal of Computer Standards and Interfaces*, 27/6, 679-695.
- [3] Frei, Ch., Kostic, T. More than meets the eye. *ABB Review* 4/2006, 30-33.

A photograph of an industrial robotic arm, likely an ABB model, performing a welding task. The arm is orange and is positioned over a workpiece. Bright sparks are being generated from the welding point, creating a dynamic and colorful scene. The background is dark, highlighting the machinery and the welding process.

Wellness for your profit line

A new dimension of customer care with remote service
Dominique Blanc, John Schroeder

Owners of industrial plants rightly expect their production lines to operate at highest performance all the time. Any outage of a component or system in the line directly translates into loss of profit. As technical equipment is not immune to wear and tear, maintenance plant operators have had to simply expect some downtime. But this is changing fast with the ever-increasing drive for enhanced productivity to cope with growing global competition.

With its remote service packages, ABB is now in a position to keep production lines on track 24 hours a day, seven days a week. ABB's remote service combines a number of recent technologies in creating a unique system for customer care. In 2007 further innovative steps were taken to increase ABB's commitment to round-the-clock wellness of customer equipment.

Times have changed, particularly in an industrial plant – a plant operator who recognizes a failure in a production line component no longer has to wait for a service technician to fix the problem. It used to take days to inform the supplier that something was wrong, for the supplier to send a service technician to get an overview, a service engineer to be contacted, spare parts to be ordered and delivered, and the service itself to be done at the customer site. With remote service, most of these time-consuming steps can be short-cut [1,2].

Remote services use existing and cutting-edge technologies to support field engineers, irrespective of location, in ways only dreamed of as little as five years ago. The Internet, together with advances in communications and encryption techniques, has contributed enormously to this end. Remote service developments are a direct result of the changing needs of customers – customers expect more support at lower costs. Remote services are designed to maximize knowledge bases in the most cost-effective manner. The result ensures that the best knowledge is in the right place, at the right time, to support customers' assets. With a large number of different types of products, this can be a complex undertaking.

Remote services use existing and cutting-edge technologies to support field engineers in ways only dreamed of as little as five years ago.

Elements of remote service

Whether the service is organized in a remote or on-site approach, the equipment performance must be monitored regularly. The traditional way was to check critical operational parameters, like oil pressure, wear of parts or other conditions, and make repairs if needed, or plan for preventive maintenance within fixed intervals.

With sophisticated sensor technology and intelligence built into the device,

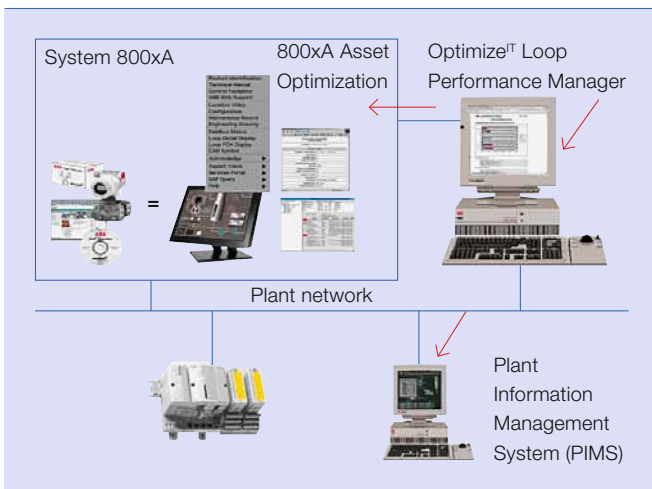
1 Performance monitoring features of ABB's System 800xA

performance monitoring today is done continuously and an analysis of the monitored parameters is performed in real-time. Most of ABB's products are equipped with such monitoring systems, and almost all parameters that determine the performance of the devices are permanently measured.

In process control systems like System 800xA, it is the utilization of the CPU and memory, the functioning of alerts and alarms or the network communication traffic, for example **1**. Pulp and paper quality control systems are checked for mechanical, electrical and electronic performance and, for example, for the reliability of the loop controls [3,4]. Drive systems undergo a continuous monitoring of voltage and current, rotational speed, motor torque and shaft power, to mention a few. Rotating machines such as motors, fans, blowers, pumps, compressors or gear boxes are analyzed for their vibration behavior, misalignments or wear of bearings **2**. The knowledge about the influence of those disturbances is evaluated with advanced lifetime prediction algorithms [5].

Instruments to measure pressure, temperature or flow are also devices that need monitoring. Here, it is the change of tolerances, communication issues, sluggishness and stiction¹⁾, for example, that need permanent checking [6]. Circuit breakers are another product to be mentioned in the list: They record a number of operational parameters essential to the service

task and are able to communicate the performance status to a remote center [7].

Remote service includes the automatic alert after a careful monitoring of the performance. This sounds easy, as most people are used to mobile phones and high-speed Internet connections. Reality is more complex, however; as the communication from the devices to a remote service center passes the boundaries of the customer's company and ABB, steps that require high attention with regard to data security. ABB has developed

2 DriveMonitor – Analyzing the system's heartbeat. Drive information can be utilized on various diagnostic levels – from the converter unit to the process section

processes to safely cross as many as three firewalls to provide the highest security **3**.

When the monitored signals arrive at the service center, they are automatically analyzed with the accumulated knowledge of hundreds of years of accumulated experience with the devices in focus. ABB has organized the knowledge about the equipment performance in extensive databases with algorithms to compare the actual performance of a device with the "normal" performance of a whole fleet of devices in the field. This has the

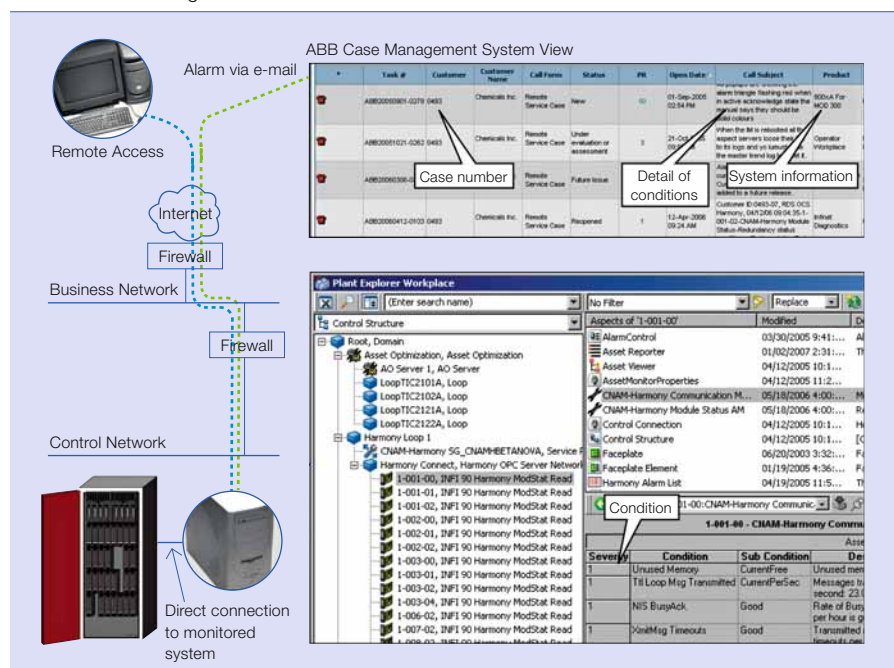
3 Remote access to devices and systems on site, and reporting relevant data to the service engineer

Process Innovations

advantage that the knowledge-based system can also propose the best suitable strategies for preventive maintenance, immediate maintenance or repair.

Every new case adds to the knowledge, and whenever the stored knowledge is not sufficient to make an optimum decision, the service center is backed up with an expert team to immediately analyze the situation. Once the situation is clear and decided upon, requesting local service personnel and potentially ordering spare parts, as well as generating appropriate instructions for the actual service operation, is a question of minutes with the help of the knowledge-based system.

Talking robots

ABB has a fleet of more than 150,000 robots in operation. These robots weld car parts, fix metal pieces, grind pieces from foundries or sort small pieces of chocolate with very high speed [8].

The robots play a crucial role for high productivity and availability of a production line. Any problem or reduced performance of a robot has a direct negative influence on the output of

the line. The end user's expectation is to avoid delays and disturbances during production.

Still, in case of malfunctioning, a service engineer would look into the "logbook" of the controller and determine the cause of the reduced performance. But this takes some time, especially when the service engineer first has to travel to the site to carry out the diagnosis.

Remote service significantly reduces equipment downtime and the customer's on-site maintenance effort.

ABB has developed a communication module that can easily be plugged into the robot controller for both old and new robot generations. This module reads the data of the controller and sends them directly to a remote service center, where the data are automatically analyzed. This is another example of the ever-growing application of machine-to-machine technology, which ABB has now pioneered in the world of robots. By accessing all relevant information on the robot conditions, the support expert can remotely identify the cause of a failure and provide fast support to the end user to restart the system. Many issues can hence be solved without a field intervention. In a case where a field intervention is necessary, the resolution at the site will be rapid and minimal, supported by the precedent remote diagnostics [4].

This automatic analysis not only gives an alert when a failure with the robot occurs but also predicts a difficulty that may present itself in the future. For that, the robot performance is regularly analyzed and the support team is automatically notified of any condition deviation. The customer benefit achieved with this innovative paradigm shift in the way service is performed, is obvious, and ABB has an impressive track record for realized savings.

ABB is proud of its achievement of providing efficient remote service to

its customers: a service that virtually brings a crew of knowledgeable experts to the customer site in the most cost-effective manner. At any time and from anywhere, a user can verify robot status and access important maintenance information about that robot system by logging into ABB's MyRobot Web page [5].

Remote service significantly reduces equipment downtime and the customer's on-site maintenance effort. With the secure and proven remote connectivity technology, the customer can be sure to have the best experts available 24/7. Remote service is one of the ABB showcases for innovative process management. This new technology is made available to customers as part of a service agreement.

Dominique Blanc

ABB Robotics
Västerås, Sweden
dominique.blanc@se.abb.com

John Schroeder

ABB Automation Technologies
Westerville, OH, US
john.schroeder@us.abb.com

- 4 Robot controller data are available at the remote service engineer's personal computer via a direct communication link



- 5 Customers can track relevant data of their robots on their personalized MyRobot Web page

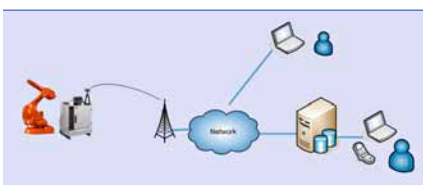

Footnote

¹ Stiction is static friction.

References

- [1] Cheever, G., Schroeder, J. (2007). Remote services. *ABB Review Special Report Automation Systems*, 13–16.
- [2] Pinnekamp, F. (Forthcoming: 2008). *Service Automation*. Ed. Shimon Nof, Automation Handbook. Heidelberg: Springer.
- [3] Horch, A. (2007). Control loops – pleasure or plague? *ABB Review Special Report Automation Systems*, 25–29.
- [4] Rode, M., Dombrowski, U., Budde, J. What loops can tell us. *ABB Review 3/2007*, 76–79.
- [5] Wnek, M., Orkisz, M., Nowak, J., Legnani, S. (2007). Drive monitor. *ABB Review Special Report Automation Systems*, 21–24.
- [6] Keech, R., Hayes, B., Mizzi, T. (2006). AquaMaster™. *ABB Review Special Report Instrumentation & Analytics*, 6–9.
- [7] Reuber, C., Gritti, P., Tellarini, M., Helmbach, M. Integrated. *ABB Review 1/2004*, 17–21.
- [8] Fixell, P., et al. A touching movement. *ABB Review 4/2007*, 22–25.

On-site transformation

TrafoSiteRepair™ combines the old with the new to improve power transformer availability

Lars Eklund, Pierre Lorin, Paul Koestinger, Peter Werle, Björn Holmgren



A reliable supply of electric power is essential and a failure of any one of the installed equipment is expensive not only for utilities but also for the manufacturing industry. A power utility may lose revenues and incur penalties for non-delivery, while the failure of an industrial transformer, for example, may lead to lengthy and therefore costly downtime. Using dedicated solutions, ABB has been helping power utilities and electricity intensive industries to improve equipment and production efficiency as well as reliability by minimizing the number of failures, and if one does occur, by getting the equipment back into service in the shortest possible time.

However, outage time has been reduced even further by newly developed ABB processes which allow transformer repair, refurbishment or retrofit to be carried out completely on-site. Packaged and marketed globally under the name of TrafoSiteRepair™, it is a combination of years of experience and state-of-the-art technology, and some 200 units in 25 countries are evidence of its success.

A transformer fails in an aluminum smelter plant but production isn't immediately affected because the plant owner had the foresight to build redundancy into the system. However, he knows that the loss of another key component will be expensive in terms of downtime and loss of output, and therefore the transformer must be repaired or replaced as soon as possible.

Normally a power transformer can be maintained and retrofitted on-site. However, major repairs, such as repairing or replacing the windings, mean the transformer must be transported to a factory where the required space and equipment are available. If the transformer is large and the distance to the factory great, the time it takes the component to get there, not to mention the costs and risks involved, will strongly influence when the transformer can resume normal operation. Unfortunately this could take anywhere from 2 to 24 months before it is fully back up and running. To overcome these problems, ABB began work some years ago to develop processes that allowed engineers to perform major repairs on-site.

The result is an innovative process that combines the old with the new. With it ABB can now not only repair and have the transformer back in operation, on average, in less than seven

Process Innovations

months, but the quality of the repair work done can even be improved. Known as TrafoSiteRepair™, it is a solution for repairing, refurbishing and retrofitting transformers on-site. It includes verified repair processes that are of the same quality and standard as those used in a factory environment. To date, some 200 units, which include utility, industrial and HVDC transformers and reactors, have been repaired or refurbished – and in many cases the latest transformer technology has also been applied, resulting in devices with a higher rating.

The TrafoSiteRepair™ process

A typical factory and workshop that manufactures and repairs high voltage equipment is characterized by its orderly layout, cleanliness and well-controlled atmosphere. It also possesses heavy lifting equipment, special tools and fixtures, high voltage test laboratories, and experienced operators for each step of the process. The same indoor environment must exist on-site if various transformer repair scenarios are to be successfully carried out. A temporary workshop, equipped with the same type of tools and equipment as used in a factory, will be set up if a repair area is not immediately available at a customer site. Heavy lifting equipment, if needed, will also be supplied. This is required because the largest transformers, with a weight of up to 400 metric tons, need their active parts to be untanked and tanked.

While the factory can be brought to the transformer as opposed to the other way round, certain obstacles had to be overcome to make this possible. The first centered on the need

for reliable transformer testing during the different stages of repair, refurbishment or retrofit. However it was the high-voltage test, the final test performed before installation and commissioning, that created somewhat of a challenge. In the past, motor-generator sets were used for high-voltage testing of power transformers on-site. Motor-generator sets are quite heavy and therefore difficult to transport. They also lack the flexibility to adapt to the test frequencies of different transformers, requiring instead a high rating relative to the test power required. Additionally, on-site maintenance requirements have to be taken into consideration. To overcome the portability and flexibility problem, ABB has developed a sophisticated *Mobile High-Voltage Test System* together with test system suppliers and suppliers of high power electronic converters.

TrafoSiteRepair™ is a solution for repairing, refurbishing and retrofitting transformers on-site and is a combination of years of experience and state-of-the-art technology.

The second hurdle concerned the drying system. Moisture is the enemy of organic insulation (eg, insulation paper) in power transformers because it speeds up the degradation process, which in turn affects the reliability of the transformer and reduces its technical lifetime. It is therefore of the utmost importance to dry the insulation paper in a transformer whenever it has been exposed to air. To do this

successfully, ABB developed an innovative on-site transformer drying system based on a low frequency current. Known as the *Low Frequency Heating drying system*, it is used in combination with the hot oil spray method, and when compared to other drying methods it reduces drying time considerably to provide a more than satisfactory moisture level of below one percent.

These two innovations are discussed in greater detail in the following paragraphs.

Mobile High-Voltage Testing System

ABB's Mobile High-Voltage Testing System can be used to test even the largest power transformers available. A complete testing laboratory is contained within a 40-foot (about 12 m) container that can easily be transported over land sea and air ^{1a-1c}. At the heart of the system is a powerful static frequency converter which can generate the required test power in the frequency range between 40 and 200 Hz. This enables tests to be performed at the most favorable frequency – as determined by internationally agreed-upon standards to minimize the required power for the test. The mobile test system performs applied and induced voltage tests, which can be combined with the partial discharge (PD) measurements to evaluate the integrity of the equipment. In addition, measurement of no-load losses and impedance may also be performed.

The set-up of an induced voltage test is shown in **2**. In this scenario the frequency converter can be tuned to the self-compensating frequency of the test set-up, and in the case of a

1a The Mobile High-Voltage Test System, built into a 12 m container, arrives on-site



1b A typical set-up for transformer testing at a nuclear power plant



1c Mobile High-Voltage Test System control room



2 Induced voltage test set-up

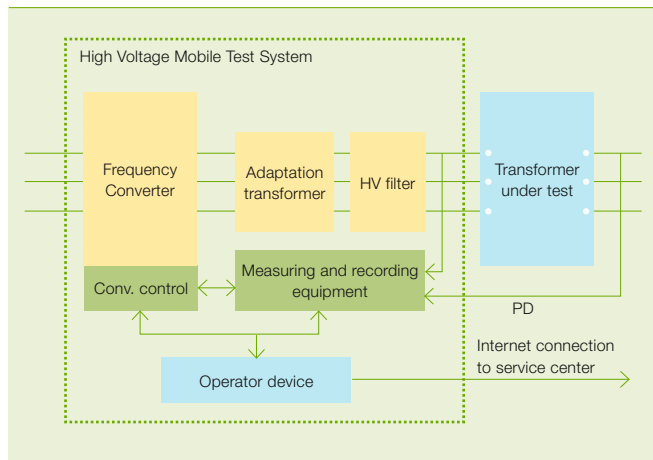

3 Applied voltage test set-up

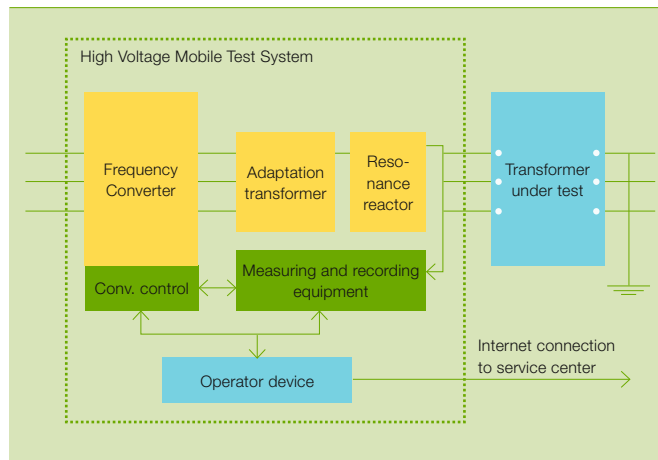

power transformer, this is normally in the range between 70 and 120 Hz. By performing the test at this frequency, the power required for the test circuit will be limited only to the active losses. The adaptation transformer is designed to match the normal voltage range applied to the tertiary voltage windings of power transformers.

For an applied voltage test, a resonance circuit is formed by the capacitance of the test object and the resonance reactor of the test set-up 3. These two components define a certain resonant frequency which is automatically detected by the static frequency converter control system.

Drying power transformers on-site

Maintaining the dryness of the insulation is of the utmost importance. Windings and insulation components are manufactured at one of ABB's transformer factories and are then vapor-phased and impregnated. Prior to shipping and assembly, they are carefully packed to maintain the required level of dryness. However, during the repair process, the insulation paper and cellulose components are affected by exposure to air during assembly and must therefore be properly dried. Moisture not only speeds up the degradation process but it can also have a direct impact on the reliability

of the transformer as water droplets can lead to an internal short-circuit.

A typical drying process for power transformers uses vacuum and heat, ideally at the same time. But a vacuum thermally insulates the inner part of the transformer (much like the workings of a thermos flask) making heat transfer to the windings virtually impossible with external heating. Instead, conventional site drying processes normally include a heat cycle followed by a vacuum cycle. These processes can last up to several weeks before the correct moisture content is reached. Other disadvantages include:

- Limited drying temperature as the heat transfer media is oil.
- A substantial temperature drop during the vacuum cycles because of the energy needed to evaporate the moisture.
- Several heating cycles are needed which expose the insulation paper

to heat and oxygen, stressing the insulation.

- Oil spray processes cannot reach the inner part of the windings because of a protective cover.

To overcome these disadvantages, ABB developed its new on-site transformer drying system known formally as Low Frequency Heating (LFH). LFH, together with the hot oil spray method 4 and 5, uniformly heats the transformer low- and high-voltage windings in a vacuum using a low frequency (of approximately one hertz) current. The LFH system heats the windings from the inside while the hot oil spray method heats the outer parts of the insulation system. The main advantage of this process is the speed at which drying can be achieved. When compared with effective systems like hot oil circulation or hot oil spray, LFH increases drying speed by a factor of between two and four. The hot oil and vacuum or hot oil spray processes are still used with TrafoSiteRepair™ and add to the quality of the repair work, but LFH is considered the most effective solution when repair time is critical.

The DFR method

Once drying has taken place, the remaining moisture level in the cellulose insulation of a transformer needs to be determined. This has traditionally been done on samples and test blocks taken out of the

4 Plant concept for a mobile LFH drying process in combination with hot oil spray

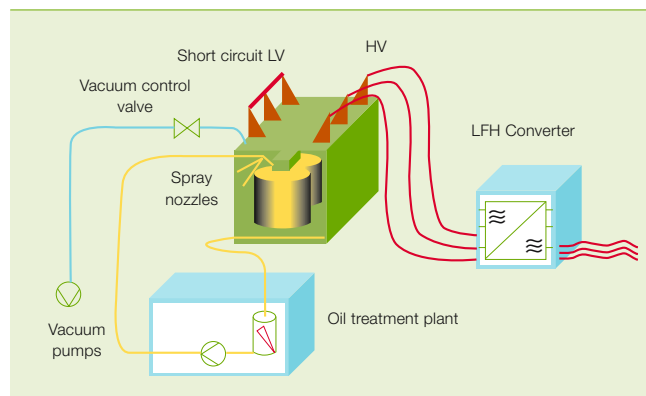

Process Innovations

transformer using the Karl Fisher method (KF). ABB has developed an alternative method using a recently developed diagnostic tool, a Dielectric Frequency Response test (DFR) for transformer insulation system testing. This new method compares power factor measurements over a wide frequency range – provided by the DFR test – with a transformer model that is based on the dielectric properties of oil-impregnated cellulose at various conditions. The detailed information required for the model is obtained from transformer insulation system manufacturing drawings.

Since the effect of moisture and ionic contamination on the dielectric properties of the insulation system is more pronounced at low frequencies, the preferred measurement frequency range is between 1 mHz and 1 kHz. The dielectric properties evaluated by the DFR test are the real and imaginary capacitances (or permittivities) and the dissipation factor. In 6, an example of a DFR measurement for a transformer with 0.5 and 3 percent moisture is shown.

This DFR measurement is then compared to the model that represents the transformer insulation materials and structure that has been measured. In the modeling procedure, the design information and DFR test data de-

6 Graphical representation of a Dielectric Frequency Response (DFR) test for a transformer with 0.5 and 3 percent moisture. The model is fitted to the transformer with 3 percent moisture

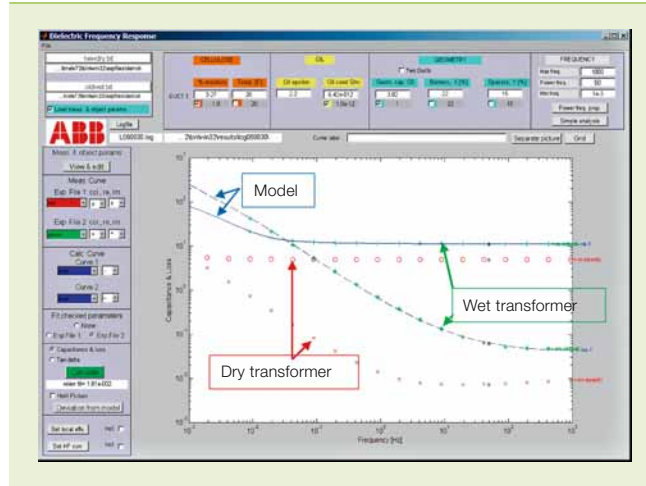

scribed above are the inputs. An algorithm calculates the response of the composite system model and the “moisture in cellulose” and “oil conductivity” values are then optimized to form a best-fit of the calculated response curve to the measured DFR data.

The two main advantages of this method over the KF one are:

- The condition of the insulation may be assessed without having to open the transformer.
- Measurements taken at multiple frequencies provide more information which makes it possible to distinguish properties of both the cellulose and oil insulation separately.

In addition, DFR is a non-destructive test that provides an overall evaluation of the moisture within the bulk insulation more precisely than KF tests on local paper samples. The assessed moisture is more representative than that of a dew point measurement, which is sensitive to surface moisture rather than the moisture of the bulk insulation. The DFR test, when compared with a power factor test, can better differentiate between moisture versus contamination, and moisture in the paper versus higher oil conductivity. And finally, assessing the moisture on a unit after repair and before it is put back into service is difficult with an oil sample since the accuracy of the evaluation is poor at low temperatures. The DFR test has

also proved useful in discovering other transformer insulation defects such as bad core grounding or carbon tracking deposits. For these reasons, ABB uses DFR as a quality control tool after repair.

The on-site advantage

Repairing, refurbishing or retrofitting power transformers on-site, irrespective of whether they are located in transmission or distribution substations, power generators or power-consuming industries, has long been accepted as the best method of getting units back into service in the shortest possible time. ABB's

TrafoSiteRepair™ offers greater speed than ever before by minimizing the outage time of the transformer, the unavailability of the power supply and more importantly, the loss of revenues for the owner. It is the result of innovative processes created in an innovative environment by innovative people.

5 On-site drying of a 750MVA/500 kV core type autotransformer with LFH heating combined with hot oil spray

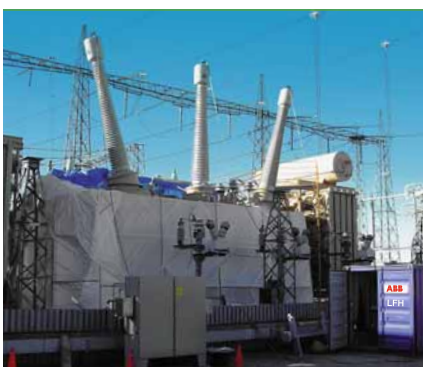

Lars Eklund
ABB Power Products
Ludvika, Sweden
lars.i.eklund@se.abb.com

Pierre Lorin
ABB Power Products
Geneva, Switzerland
pierre.lorin@ch.abb.com

Paul Koestinger
ABB Power Products
Baden, Switzerland
paul.koestinger@ch.abb.com

Peter Werle
ABB Power Products
Halle, Germany
peter.werle@de.abb.com

Björn Holmgren
ABB Corporate Research
Västerås, Sweden
bjorn.holmgren@se.abb.com

Integration guaranteed

Taking Process Analytical Technology (PAT) to the next level

Chris Hobbs

In the pharmaceutical industry, it takes approximately 12 years to bring a new drug to market at a cost in excess \$800 million! While this is without doubt a staggering figure, it looks set to increase because new pharmaceutical products, which are more focused on what they can treat, cost more to develop. The overall result is increased development costs with less return. However this increase in investment does not seem to have had any impact on the number of New Chemical Entities (NCE) being approved. In fact, the approval rate is in decline. In addition, increasing costs have forced the industry to look at new and innovative ways of becoming more efficient, both in the creation of new drugs and the production of existing drugs. One of the leading initiatives, which does seem to be making an impact, was launched in 2002 and is called Process Analytical Technology (PAT). At the heart of any PAT system is the process analyzer. However, the availability of multiple analyzer platforms and the absence of some form of standard for exchanging data has resulted in the creation of "islands of PAT."

The problem – until now that is – has been the lack of any form of integrated solution. Over the last few years ABB has worked closely with leading pharmaceutical companies culminating, in the release of the ABB's Industrial IT for Process Analytical Technology in 2007. This scalable purpose-built solution meets the key requirements of a truly integrated PAT solution.

Process Innovations

Pharmaceutical manufacturing processes are highly complex. Quality, yield and the cost of operation are affected by the interaction of many variables. Yet performance improvement has never been more critical to success and survival, and achieving this depends largely on how well the complex variability of the process is understood. In the pharmaceutical industry, process analyzers are used for this purpose, as well as to ultimately control quality variations in the production process. Analyzer technology has been used successfully in both the R&D and production life cycles on single-unit operations, such as blending and drying, and it is playing an increasingly important role in identifying and understanding the variations that occur between laboratory and production equipment during scale-up. Such is the impact of this technology that it became a central feature of the PAT (Process Analytical Technology)¹⁾ initiative launched by the Food and Drug Administration (FDA) in 2002.

Five years on and this initiative has resulted in analyzer companies and third-party integrators providing their own stand-alone PC solutions capable of controlling single-unit operation, and which can export predicted values (such as moisture content or average particle size) to third-party DCS and SCADA systems. To put it another way, various PAT analyzers exist that can be used in unit operations such as reaction monitoring, fermentation,

blending and drying. However, the availability of multiple analyzer platforms and the absence of any real standard for exchanging data has led to the creation of “islands of PAT.” Gathering information from separate unit operations is complicated by the fact that all analyzers have different user interfaces and data formats. To overcome this, there is a need for new tools to execute complex PAT methods using a standard and PAT-friendly interface.

PAT – the next level

Recently, pharmaceutical companies have been investigating the possibility of using analyzer-based control so that traditional batch processes can be run in a continuous manner. For this to work successfully, the coordination of multiple analyzers measuring different types of data from multiple unit operations is required. Tight integration with existing control and information technology is needed to control and maintain an electronic record of the production process.

Joint ventures between process control and analyzer companies have resulted in bespoke solutions that have contributed to achieving this goal. However, fundamental differences in data types as well as the quantity of data collected have stressed the traditional control and data management environments. Analyzer platforms produce large amounts of data of differing formats (eg, spectra, bar graphs, chromatographs and images). These

in turn require large array-storage facilities that are over and above that which is normally available on a DCS or SCADA historian. The acquisition of knowledge data from different analyzer platforms must be synchronized with data from other third-party systems, such as DCS, SCADA and LIMS, and stored in a structure that is defined by a particular production model (eg, S88²⁾ Batch control standard). Finally, the data needs to be easily accessible to third-party manufacturing management systems as well as to other lifecycle management and regulatory systems to create what is known as a Collaborative Production Management (CPM) environment, linking the process through to the production management system. In short, an integrated and flexible IT environment is needed to make this possible, and the good news is that such a solution now exists.

Just what the industry ordered

ABB is both a control system and analyzer solution supplier, and over the last few years the company has used its knowledge and expertise in these

Despite a massive build-up in research funding, the number of new treatments approved each year has fallen.

(Source: Datamonitor, PhRMA)

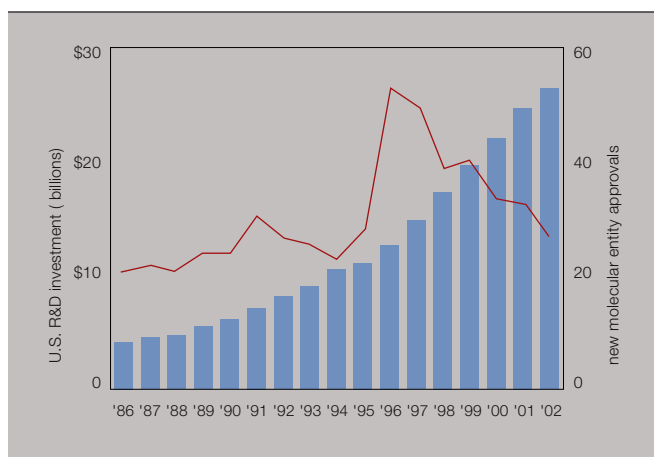

1 The PAT Method

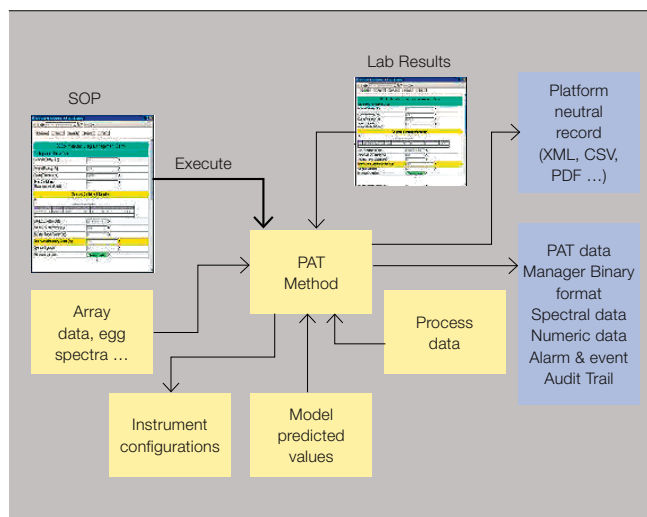

Footnotes

¹⁾ “PAT is a system for designing, analyzing, and controlling manufacturing through timely measurements (ie, during processing) of critical quality and performance attributes of raw and in-process materials and processes with the goal of ensuring final product quality.” (www.fda.gov/Cder/OPS/PAT.htm, October 2007)

²⁾ S88 is a standard addressing batch process control. It is a design philosophy for software, equipment, and procedures.

areas to form successful collaborations with leading pharmaceutical companies. These collaborations have culminated in the release of *ABB's Industrial IT (IIT) for Process Analytical Technology* in 2007. This scalable purpose-built solution meets many of the key requirements of a truly integrated PAT solution including:

- A common Human Machine Interface (HMI) for all analyzer types.
- A data exporter, which allows the extraction of synchronized single-point and array data collected from multiple analyzer platforms by specified equipment or the direct transfer of data to third-party modeling packages.
- A universal adaptor to allow for ease-of-interface to new and existing analytical devices.
- A central PAT configuration method including version control.
- A central S88-type data storage for all data and data types including array (eg, spectral or histogram), predictions, statistics, alarm, event and audit trail.
- The ability to operate multiple analyzers/analyzer channels at the same time over multiple unit operations.
- The ability to pause and reconfigure an analyzer during the execution of a PAT procedure, while other analyzers remain operational.
- Supports the use of electronic signatures.
- It is aligned with ICH guidelines 8, 9 and 10 (draft).

A truly integrated approach

With ABB's solution, a user can start with a single-unit operation before scaling-up to accommodate multiple analyzer platforms distributed over multiple unit operations and production plants. It can function stand-alone or with existing DCS/SCADA platforms. In addition it can integrate seamlessly with ABB's own System 800xA Distributed Control and Safety System.

To overcome the problem of interfacing to many disparate analyzer data formats, ABB has created standard drivers to allow existing and new analytical devices to connect to the FTSW800 Analyzer Controller Platform. This is further enhanced by a tool kit enabling third-party integrators or other analyzer platform vendors to create their own interface to the ABB standard.

ABB's Industrial^{IT} for Process Analytical Technology eliminates the so-called "islands of PAT" by creating integrated process based solutions.

Developing data standards

For a truly integrated solution, the data exchange between analytical devices and third-party platforms needs to be seamless. This can be achieved if a

common standard exists that defines the approach. ABB has been behind the formation of an OPC³⁾ Foundation Working Group whose purpose is to define a standard approach of interfacing analyzers over OPC UA (Unified Architecture). The vision of the group is to provide a means for vendors to write standard device drivers that publish the capabilities of process and laboratory analyzers over OPC UA data links. These drivers will allow complete access to all low-level and high-level data, and will be compatible with regulated manufacturing environments. In particular the OPC working group has been formed to focus on the PAT requirements for the life sciences industry.

Managing the data

If PAT data is to be useful, it should be stored in a structured and regulatory compliant manner so that it can be easily viewed, exported and validated. Typically this requires knowledge of what stage the process is at, and which process equipment, equipment port, analyzer and analyzer channel is in use. Because not all analyzers function in real time – and those that do may be sampling at different time periods – the data must be synchronized to provide a common time-frame reference.

In order to achieve this, ABB has included a Data Manager within its

Footnote

³⁾ OPC is a standard communication protocol.

2 Preconfigured trend displays allow easy access to model predictions and their associated scores and statistics

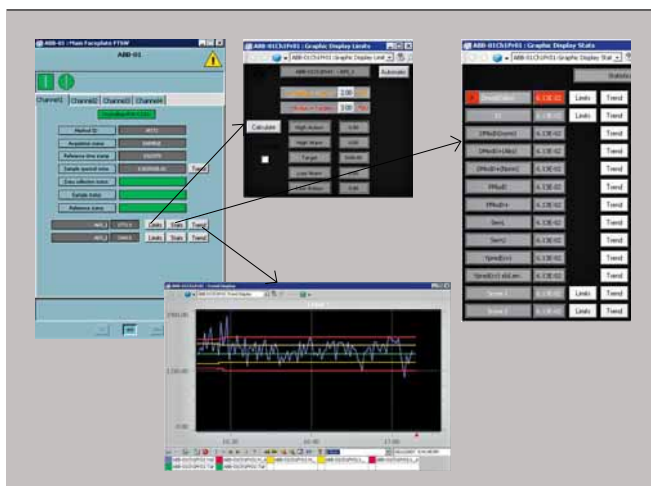

3 The PAT Data Analysis tool can display data in 2D and 3D views

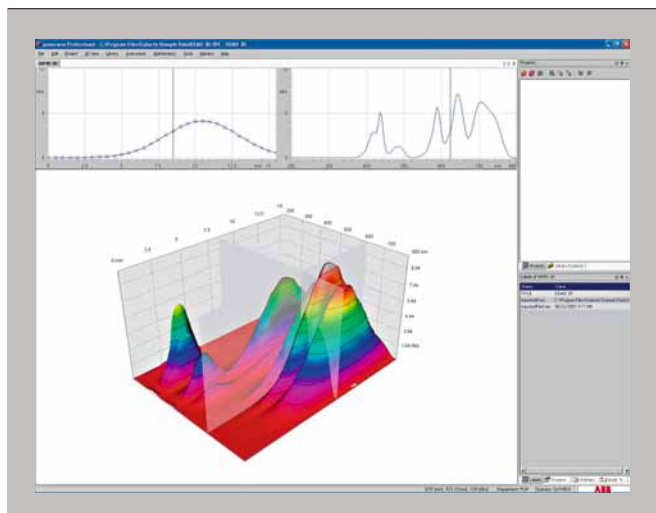

Process Innovations

IIT PAT solution. This Data Manager ensures that all data is stored in an S88-type manner. Adhering to S88 guidelines means the information concerning the location of an analyzer probe, as well as the batch the analytical data belongs to, is also included. Data is stored by time and date using an enhanced history engine which is capable of storing a mix of formats, including array (spectral, chromatograph), single-point (predictive values and their associated statistics) and event (alarms, audit trail) information. Such a combination ensures that PAT Method data can be easily identified by batch, equipment, analyzer and channel. Finally, the addition of a dedicated export engine allows the user to export data, using the same S88-type structure, in formats that are compatible with third-party modeling packages.

The PAT Method

A PAT Method **1** is a set of instructions that dictate the operation, development and validation of the analyzer-based models. These models in turn monitor, predict and control the Critical Quality Attribute (CQA).

The PAT Method is configured graphically **2**. A PAT Method describes the production area and analyzer equipment that will supply the data, and dictates the data storage structure and analyzer configuration required. It is version-controlled, and a standard set of libraries based around analyzer types enables quick and efficient configuration. The PAT Method can operate as a

stand-alone feature or it can be externally triggered from third-party platforms, such as existing DCS/SCADA systems or batch managers.

Data visualization

The PAT Method can be scheduled or triggered remotely by OPC tags, and once running, its progress may be followed using the Procedure Function Chart tool. Analyzer information is then forwarded to standard library face-plates and graphical displays⁴. As well as raw data values, meta data such as PAT Method name, version, equipment name, port name and key diagnostics from the analyzer are also displayed. Preconfigured trend displays allow easy access to model predictions and their associated scores and statistics **2**. Preconfigured warning and alarm levels are trended to give an early indication of quality deviation.

Data analysis and model building

ABB provides its own PAT data analysis tool and the ability to export data to third-party tools. This data analysis tool:

- Provides data mining of PAT Method data
- Displays analytical data
- Provides 2D and 3D views of the data **3**
- Provides wizard-driven univariate and multivariate model builders
- Supports MLR, PLS1, PLS2, PCA and PCR models

Exporting data

There are a number of different modeling and analytical packages available that will only accept data conforming to some common synchronized format. Achieving compatibility entails some form of manual and time consuming data extraction and alignment activities which, most likely, requires the use of additional software.

ABB's Data Export tool overcomes this problem by exporting PAT data from running or completed PAT Method procedures in formats that are compatible with existing packages, such as ASCII (tab or comma separated) or GRAMS SPC. This flexible tool is designed to run locally on the Data Manager or on a third-party remote PC platform, and the exported data

may be sent to one or multiple files. Navigation displays, like the one shown in **4**, allow the user to select data from multiple analyzer platforms – by choosing either unit procedure, equipment, analyzer channel or data tag – across one or multiple production batches. Additionally it is possible to extract different parcels of data by selecting different time slices.

Still much to do

Although still in its infancy, many of the benefits of PAT can be seen as new techniques and analyzers are developed. However, if the full benefits of the FDA initiative for PAT are to be realized, recognition by many existing roles (QC, automation, validation, etc.) is required together with the appropriate training and the ability to identify opportunities for using PAT in their processes. ABB's engineering services for PAT support users in these areas, along with validation, regulatory compliance and other business improvement consultative services. In any case, a standardized global approach is still needed. System suppliers must help to create this standardization, especially in key areas such as data handling. In addition, a solution is needed to break down the barriers created by multiple disparate systems. ABB is such a supplier and ABB's IIT for PAT is such a solution.

4 A typical data selection screenshot from the PAT Data Export Tool

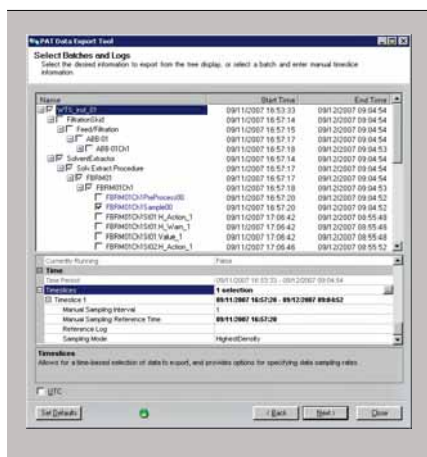

Chris Hobbs

ABB Ltd.
IIT PAT MEC (Europe)
St. Neots, UK
chris.hobbs@gb.abb.com

Footnote

⁴ These may vary depending on the analyzer type but not between analyzer products. In other words, an NIR (Near Infrared) faceplate is the same for both an ABB and Bruker NIR analyzer.

Further reading

Roy, J., "Process Analytical Technology," *ABB Review Special Report on Instrumentation and Analytics*, 2006, 61–64.

Efficiency up, emissions down

Achieving higher power plant performance with advanced process control
Pekka Immonen, Ted Matsko, Marc Antoine

Coal-fired power plants have come a long way in the last decades to become generators of electrical energy with high efficiency and sharply reduced emissions. Big steps have been taken particularly with improved boilers, steam turbines and improved cycles.

Only recently, however, were advanced process control technologies – well established in other industries – made available for power plants. ABB's multi-variable model predictive control (MPC) has now demonstrated its superior performance and realized significant energy savings and emissions reductions. The plants utilizing ABB's technology have realized NO_x reductions of eight to 40 percent, while generating tens of GWh per year of additional electrical energy with the same fuel consumption.



Process Innovations

Multi-variable model predictive control (MPC) is a technology with superior performance over traditional single-input/single-output control strategies **Factbox**. Originally developed for petroleum refineries, MPC has become common in process industries over its 30 years in applied practice. Only recently, however, has MPC found its way to power plant control and optimization.

This slower progress in the power sector can be partially explained by higher performance requirements. The dynamic behavior of power plant components is usually much faster than that found in petrochemical processes, and it requires computing power that until recently was either not available or not cost-effective. In times of low primary energy cost and less strict requirements on environmental issues, the economic advantage was also not as substantial.

The increasing performance of computers has now made it possible to apply MPC to demanding large power plant applications. For industrial power plants, smaller in size, MPC solutions have already been implemented, focusing on coordinated control and optimization of multiple boilers, fuels, turbines, steam headers and power flows to and from the grid. The range of benefits in industrial power plants, such as improved plant stability, higher availability and lower overall energy costs, have paved the way for a wider application in large power plants [1].

The most common application of MPC for large utility power plants today is combustion optimization, dealing with optimum distribution of fuel and air in the boiler to reduce emissions (particularly NO_x), while improving combustion efficiency [2].

More recently, MPC-based solutions have been deployed in other areas of the plant, such as main and reheat temperature control and boiler-turbine coordination. ABB's OPTIMAX® portfolio addresses these solutions and contains a variety of technologies, such as the Predict & Control software, which is among the most advanced MPC solutions applied in both industrial and utility power plants.

Performance improvement with MPC
The primary objective of advanced process control is to reduce process variations. For power plants, this means improved process stability and reliability, and reduced thermal cycle stress on the high pressure parts.

With reduced variance, the power generation process can also be oper-

ated closer to the given plant's optimum. In many cases, this optimum is defined by constraints. By minimizing variations, the process can be pushed closer to its limit without violating the constraint **1**.

In a utility power plant, a large number of possible process constraints exist. Some of these are listed in **2**. The benefits from operating closer to the limits include improved heat rate, higher generation capacity and lower emissions.

Multi-variable model predictive control also facilitates faster ramp rates, while keeping the plant within the acceptable operating envelope in the ramp-up. This can be very beneficial for units in cycling operation, and in boiler runback situations.

ABB'S Predict & Control

Historically available MPC packages, often used to implement advanced control solutions in process industries, show a number of serious deficiencies [3].

- There are limitations in the choice of control models. The commonly available impulse and step response models can only be applied for inherently stable processes, and they handle integrating processes poorly
- The controllers work poorly in the presence of significant measurement noise or unmeasured disturbances
- Model identification relies on open loop step testing, and only single-input/single-output (SISO) models can be identified

Without a more comprehensive commercial software solution, ABB began work on a full-fledged MPC-based system. The new product, Optimize^{IT} Predict & Control (P&C), could overcome the shortcomings of the previous solutions. P&C is based on new technology that replaces the typical collection of SISO step response models with a true multiple-in-

Factbox Multi-variable model predictive control (MPC)

MPC is a common name for control technology using dynamic process models representing the relationship between independent variables (model inputs) and dependent variables (model outputs). The inputs include manipulated variables (MV) and disturbance feed-forward variables (FF). The model outputs are called controlled variables (CV). The models predict future outputs based on 1) past values of manipulated variables, 2) calculated future values of manipulated variables and 3) past values of the feed-forward variables.

A multi-variable MPC algorithm uses inherent knowledge of the process dynamic behavior. All the interactions between the process quantities are considered in the simultaneous solution of many equations. This is different from traditional control (eg, PID control), where each controller has one input and one output. With the many constraints and complex interactions involved in power plant control, multi-variable MPC is well suited to provide advanced control and optimization in the power industry.

1 Reduced variance of steam temperature allows an operation closer to the limit

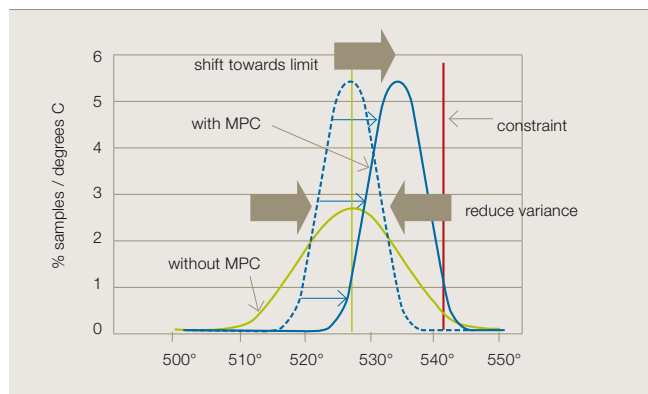

put/multiple-output (MIMO) state space model¹⁾ [4].

The new ABB algorithm identifies accurate state space models from plant test data. The ability to identify MIMO models from a single set of closed-loop tests reduces the required testing time and greatly simplifies the modeling task.

The Kalman filter is a mathematical technique that utilizes all available information to develop the best estimate of the process state and the disturbances affecting it.

The state space modeling approach permits P&C to use a Kalman filter for state estimation as part of the feedback control algorithm. The Kalman filter is a mathematical technique originally developed for trajectory estimation of space craft. It utilizes all available information to develop the best estimate of the process state and the disturbances affecting it. Besides the controlled variables, additional process measurements can be included in the model, providing the Kalman filter with more information and further improving state and disturbance estimation.

2 Examples of process constraints for utility power plants

- Maximum live steam temperature
- Maximum live steam pressure
- Maximum steam flow
- Maximum reheat temperature
- Minimum flue gas O₂ content
- Maximum opacity of flue gas
- Maximum NO_x emissions
- Maximum generator power
- Minimum condenser vacuum
- Maximum fan capacities (amps or dampers)
- Windbox pressure differential dampers

Footnote

¹⁾ A state space model describes a physical system with a number of differential equations.

The basic principle of the P&C controller is shown in **3**. At each pre-defined time interval, the controller reads actual process variable values and uses the process inputs (u) and outputs (y) to estimate the current process state (\hat{X}), input disturbances (w) and output disturbances (h). This approach is different from standard MPC packages that can estimate the output disturbances only (h). This leads to far better estimates of the state (\hat{X}) and better control of y.

Optimum MPC design

In a power plant, a large number of inputs (manipulated variables that can be set, and feed-forward variables generated by disturbances) and outputs (controlled, constraint and addi-

tional state-estimation process variables) exist that can be used for the control model. The selection of the model scope with the required inputs and outputs depends on the project objectives, plant configuration, and the specific local economic factors.

The MPC inputs and outputs for a typical combustion optimization task are illustrated in **4**. The manipulated (MV), feed-forward (FF), and constraint (CV) variables for this divided furnace boiler are indicated.

The relationships between these parameters are shown in **5**. The different rows of the matrix represent model inputs; the columns define outputs. The matrix elements with a check-

3 Basic principle of ABB's Predict & Control controller

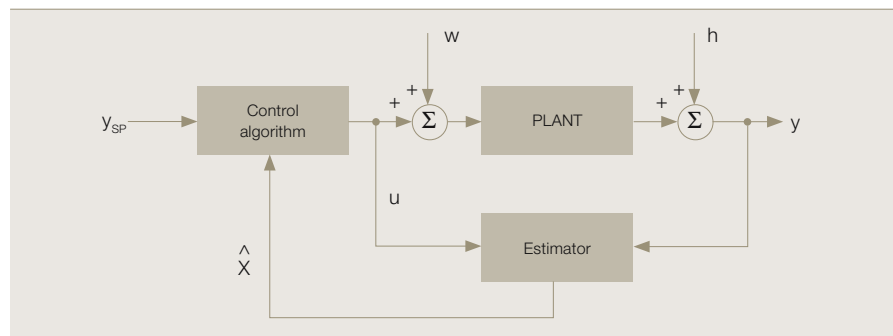

4 Combustion optimization variables

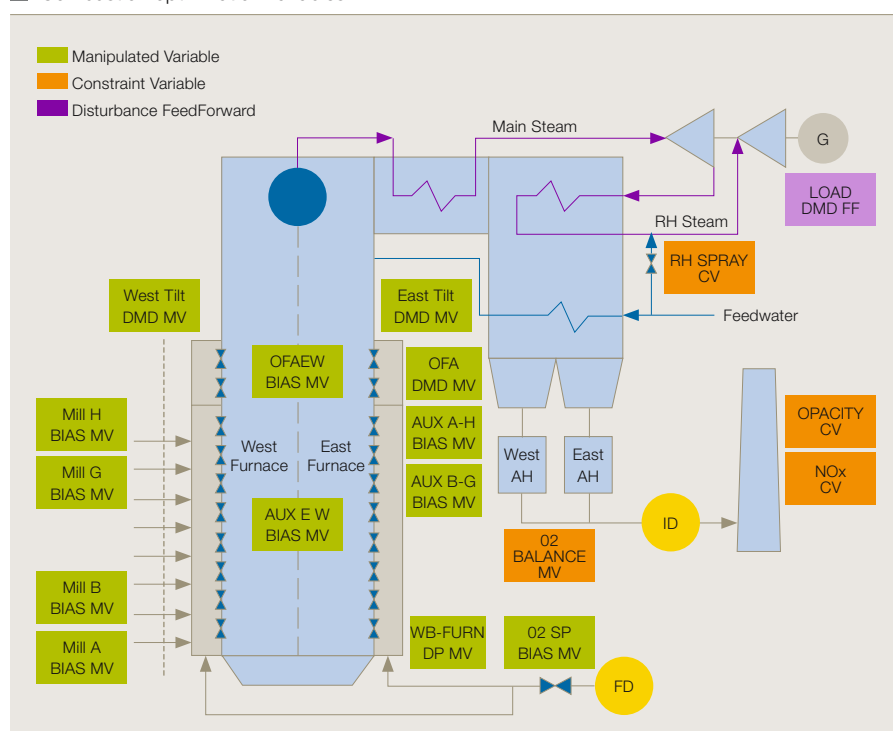

Process Innovations

mark indicate physical relationships included in the overall model.

The above scope represents traditional combustion optimization systems, where the attemperator²⁾ spray flows are included as process constraints. The purpose is to keep the base controls for main and reheat temperatures

within a favorable control range, and to minimize reheat spray flow.

Once the model scope has been defined, the engineering tools within P&C can be used to create and modify the structure of the multivariable controller. A user-friendly application browser is available to define the

manipulated, controlled (or constraint) and the feed-forward variables. Properties associated with these variables are also defined using the configuration tool.

Predict & Control is typically implemented at the supervisory level to manipulate set points of multiple base control loops implemented in the digital control system (DCS). Examples of such set points include fuel flow, attemperator flow and oxygen set points. For best results, it is important to have the base loops – including sensors, actuators and other field instrumentation – properly tuned and in good working order. ABB’s Loop Performance Manager (LPM) is part of the same Advanced Process Control Suite as Predict & Control, and the loop tuning and auditing capabilities of LPM improve the base loops prior to the MPC commissioning.

The engineering tool has a powerful data processing capability for importing, trending and filtering the collected process data, including automatic outlier identification and removal. The computational core of the modeling tools is the parametric identification tool that is used to build state space models. The state-of-the-art algorithm combines ease of use with the ability to utilize both open- and closed-loop test data in the model identification. Trend displays are provided to illustrate the fit of the identified models to the actual measurement. A boiler main steam temperature control example is shown in **6**, comparing the actual temperatures (red) to the values predicted from the attemperator spray moves (blue).

The final step in MPC design is the tuning of the controller to the specific plant. With the help of weight parameters for the various feedback loops, the MPC is tuned to produce the desired dynamic response of the plant. The tuning includes setting weights on control errors and drifts of the different variables. A large weight is set when a small control error or drift is allowed, and vice versa. Priorities are also assigned to the various constraints. In case of conflicting constraints, the one with higher priority is satisfied first. If adequate degrees of

5 Combustion optimization control matrix of input and output relationships

MV	CV ==>	NO _y	STACK OPACITY	O ₂ IN BALANCE	REHEAT A SPRAY DMD	REHEAT B SPRAY DMD
		ppm	%	% (O ₂)	%	%
O2 SP BIAS	O2 Setpoint Bias	-	-			
WB FURN BIAS	Windbox DP Setpoint Bias	-				
AA FF BIAS	Aux Air East-West Bias			-		
AA AH BIAS	Aux Air Elevation A-H Bias	-	-			
AA BG BIAS	Aux Air Elevation B-G Bias	-				
MILL H BIAS	Mill Feeder H Bias	-				
MILL G BIAS	Mill Feeder G Bias	-				
MILL B BIAS	Mill Feeder B Bias	-				
MILL A BIAS	Mill Feeder A Bias	-				
TILT DMD E	Burner Tilt East Demand	-	-		-	
TILT DMD W	Burner Tilt West Demand	-	-			-
OFA DMD	Overfire Air Demand	-	-			
OFA FF BIAS	Overfire Air East-West Bias			-		
FF						
GENERATOR MW	Unit Load Demand	-				

6 Comparison of model predicted and measured temperatures in a power plant

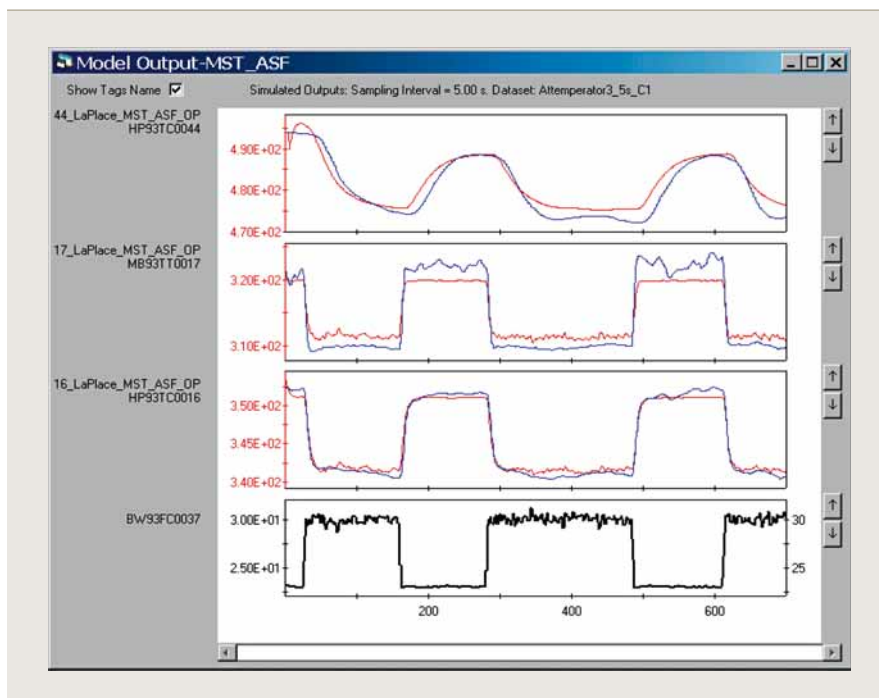

freedom and control capacity exist, additional constraints are resolved in rank order.

The whole plant at a glance

Operators of power plants need a fast and complete overview of the plant status with all details available on request. There are two ways to monitor and access the P&C-based advanced control system. The controller may use OPC to link all operating parameters to a DCS console, facilitating true single-window operation of the plant, or the operator can use the P&C Operator Interface client.

A typical optimization overview is shown in 7. It can be used to monitor the status of the advanced control and optimization, and to enable or disable optimization for any given component.

A track record of impressive savings with P&C

Advanced model predictive control systems have established a track record for improving plant operations. Some of the improvements include the following:

- Typical NO_x reductions of 8 percent at base load, and up to 40 percent at swing load
- Heat rate improvements of
 - 0.25 – 1.5 percent at base load
 - 1.5 – 2.5 percent at swing load
- Reduction of unburned carbon in ash by 1 – 5 percent
- Reduced CO₂ generation per MWh generated
- Maintenance of CO at desired levels
- Improved availability
- Accelerated ramp rates

7 Single-window overview of the status of a boiler-turbine optimization

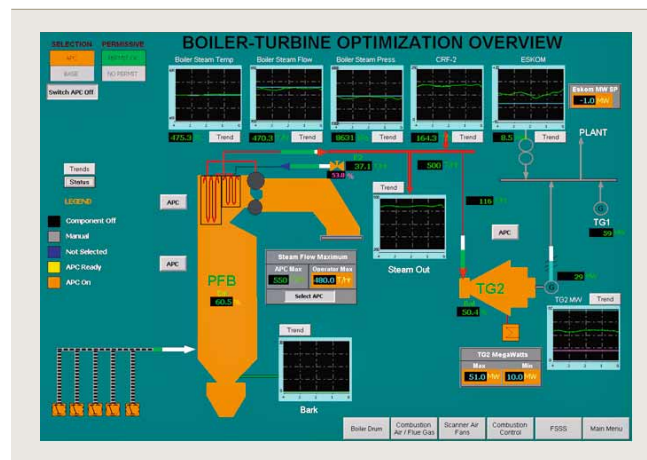

8 Improving heat rate through better main steam temperature control

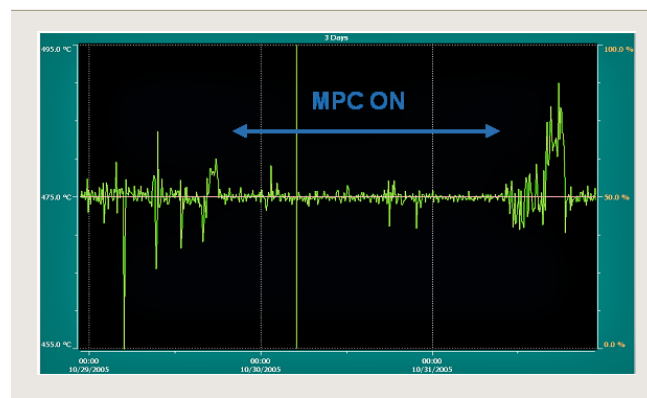

A significant improvement of the boiler performance can be achieved with an operation at the highest possible main steam temperature. 8 illustrates how temperature variations can be reduced by means of multi-variable MPC, the precondition for a safe operation at the maximum temperature. In this case, the improved control of a pulverized coal boiler reduced the standard deviation of the main steam temperature by 80 percent, allowing a set point increase of 10°C. While 10°C may sound small, the

resulting heat rate improvement was 1.2 percent, which adds up to approximately 10,000 MWh per year of additional power generated from the same fuel input.

Heat rate improvements can also be achieved by adjusting reheat spray flows as constraint variables. Because of the reduced variations in the flow rate through MPC control, they can be reduced and operated closer to the limit. By cutting the spray flow rates to one-half of the original, the corresponding heat rate improvement in another application was 0.36 percent, providing approximately 25,000 MWh of additional power per year with the same fuel consumption. At the same time, NO_x emissions fell by 10 percent.

As the examples show, MPC-based control systems have a significant impact on power plant operations, energy efficiency and emissions. MPC is a powerful instrument to meet a fast growing need in the utility business – that is, simultaneously achieving both economic and environmental benefits.

Pekka Immonen

ABB Utility Automation Systems
Wickliffe, Ohio, USA
pekka.immonen@us.abb.com

Ted Matsko

ABB Process Automation
Wickliffe, Ohio, USA
ted.matsko@us.abb.com

Marc Antoine

ABB Power Systems
Baden, Switzerland
marc.antoine@ch.abb.com

Footnote

²⁾ The attemperator is a device that adjusts the temperature of the spray flow to the required value.

References

- [1] Immonen, P., Matsko, T., Antoine, M. (2007, September). Increasing stability and efficiency of industrial power plants. Paper presented at POWER-GEN Asia, Bangkok, Thailand.
- [2] Antoine, M. Leaner, fitter, smarter. *ABB Review* 3/2005, 36–41.
- [3] Qin, S. J., Badgwell, T. A. (2003). A survey of industrial model predictive control technology. *Control Engineering Practice* (11)7, 733–764.
- [4] Bonavita, N., Martini, R., Matsko, T. (2003, June). Improvement in the performance of online control applications via enhanced modeling techniques. Paper presented at ERTC Computing, Milan, Italy.

Green ships on the high seas

ABB power turbines boost marine fuel economy and emissions compliance
Markus Rupp

Powerful turbocharged diesel engines are the prime movers of container-ships and other large sea-going vessels. The use of turbochargers significantly increases the fuel efficiency of these big ships, and the fleet of ABB turbochargers has been helping shipowners to improve their economy for many decades.

The exhaust gas of the ships' large engines is used in waste heat recovery systems to "squeeze out" more energy from fuel. In addition, there is potential for further savings when the heat recovery is tailored to specific ships.

ABB's new generation of power turbines provides innovative ways for further increasing the efficiency of large marine engines, helping to clean up air pollution and reduce shipowners' operating costs at the same time.



A large proportion – about 25 percent – of fuel energy is lost through exhaust gas dissipation. High-efficiency turbochargers for two-stroke marine engines allow some of the exhaust gas from the engines to be used for other work. One obvious use is to divert the “surplus” gas to a power turbine (connected to a generator), which converts it into useful electrical energy. This additional on-board energy translates into fuel savings and, as a result, lower operating costs.

Shipowners have, of course, long recognized the cost and efficiency benefits of this approach, and numerous waste heat recovery (WHR) systems have been installed on large vessels in the past. Between 1985 and 1994, ABB Turbo Systems delivered more than 130 power turbines with electrical power of up to 1200 kW. Many of these early systems are still successfully operating on various types of ships and continue to save money and provide ABB with an important experience base.

The shipping industry’s interest in fuel-savings, however, waned in the 1990s. Increased demand for higher diesel engine output for the ever-bigger ships required engine builders to focus their development efforts primarily on larger, more powerful

units. Oil prices, which had stabilized at a relatively low level, contributed to the declining interest in fuel economy.

Energy efficiency is back on stage

Rising oil prices and a stronger demand for environmental sustainability led to a renewed interest in energy-efficient systems in the shipping industry. In line with this clear trend, ABB began to take a fresh look at the untapped potential of WHR systems in 2001. An internal study examined the whole range of two-stroke diesel engines, with special reference to ABB’s high-efficiency TPL...-B turbochargers **1** introduced in 1999.

The TPL series was greatly appreciated by the market – by the end of 2006, more than 3500 units had been delivered or specified for over 2100 two-stroke diesel engines with a total engine output in excess of 67 million bhp¹⁾.

Increasing the fuel efficiency was, however, only half the battle. Environmental issues related to exhaust gas emissions from marine engines had begun to take precedence. As a result, ships will have to further reduce their exhaust emissions to comply with even more stringent legislation in the future, on top of their compliance with already strict IMO²⁾ regulations.

3 PTL power turbines are built in ABB’s modern factory in Switzerland



1 ABB’s TPL...-B turbocharger for two-stroke engines

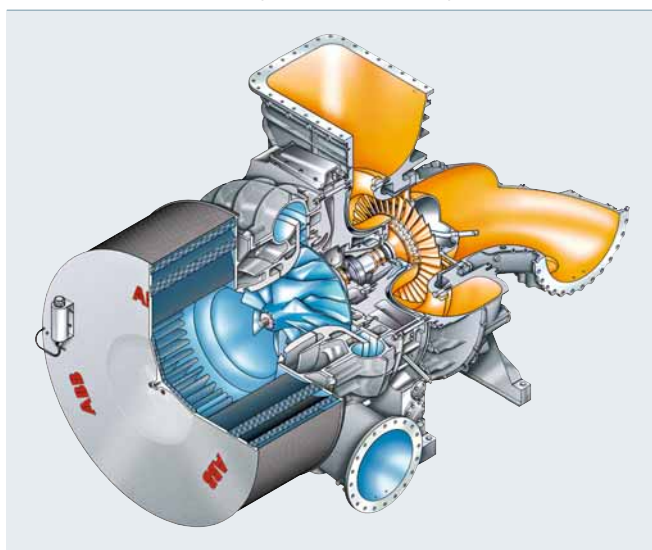

2 PTL power turbine

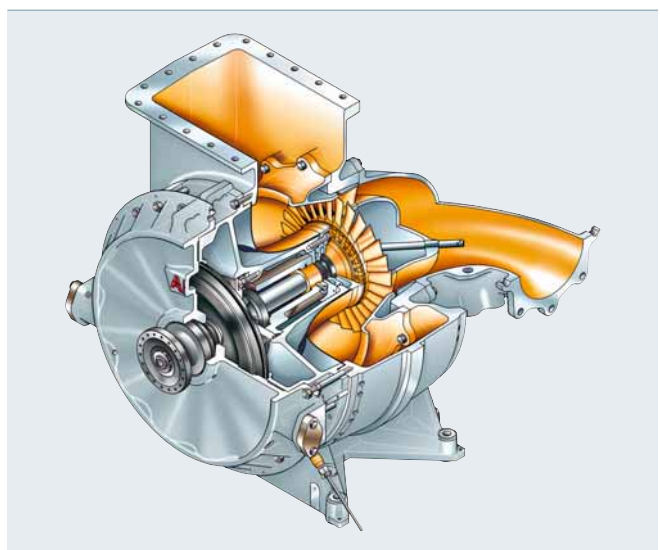

Footnotes

¹⁾ Bhp, or brake horsepower, is the power delivered directly to the crankshaft of an engine.

²⁾ IMO, or International Maritime Organization, is the United Nations agency concerned with the safety of shipping and cleaner oceans.

R&D focus

The market success of the TPL...-B turbochargers, and the end-users' growing interest in vessels being "green" as well as cost-effective, provided the rationale for developing a new power turbine incorporating state-of-the-art turbocharger technology. The result was the market launch in 2005 of ABB's new-generation PTL3200 power turbines, designed for an electrical output range of 1500 to 3200 kW [2] [3].

Tailor-made solutions for WHR systems

There are two types of WHR systems with power turbines for improving the fuel efficiency of a ship's main engine. The power turbine can be used in a stand-alone configuration, with its rotational energy directly used to produce electricity via a reduction gearbox and generator. The power turbine also can be integrated into a steam cycle. Waste heat recovery units with ABB power turbines are packaged by

the U.K. engineering company Peter Brotherhood in close cooperation with ABB Turbo Systems.

WHR with stand-alone power turbine

The layout of a WHR system with a stand-alone power turbine is shown in [4]. The power turbine and generator unit operate in a fully automated way, feeding electrical power directly to the grid or to an optional shaft motor. Besides ensuring a supply of additional electrical energy on the ship, this configuration allows an up-to-four-percent savings in fuel consumption and exhaust gas emissions.

4 Waste heat recovery (WHR) with ABB's stand-alone power turbine

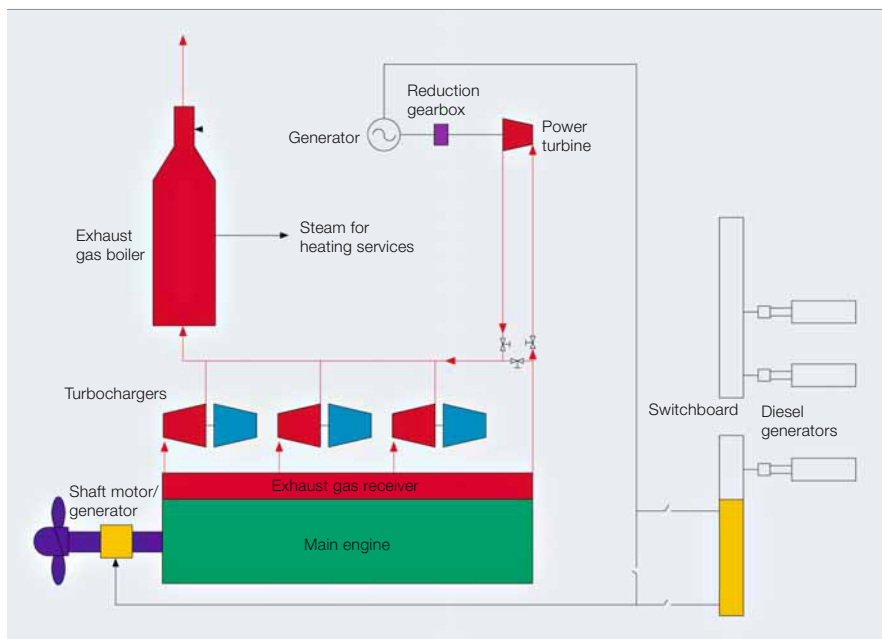

WHR with power and steam turbines

The saving in fuel and emissions can be increased to over ten percent with the WHR system shown in [5]. In this arrangement, which makes full use of the waste heat's energy potential, superheated steam is produced in the exhaust gas boiler after leaving the turbochargers and is fed to a steam turbine, which drives the generator.

ABB's PTL power turbines address two of the most pressing issues in shipping today – fuel economy and environmental compliance.

5 Waste heat recovery (WHR) with ABB's power turbine and steam turbine

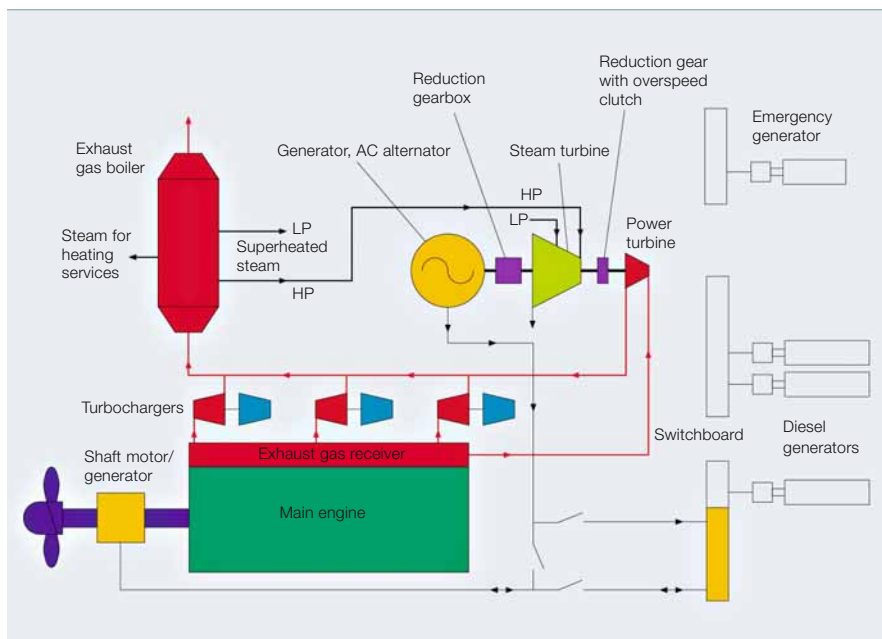

The first WHR system combining ABB's PTL3200 power turbine with a steam turbine was installed on the recently launched M/S EMMA MÆRSK from MÆRSK LINE [6]. With an official capacity of 11,000 TEU³⁾, she and her seven sister vessels are the largest container vessels in the world. The giant vessel's Doosan-Wärtsilä 14RTFlex96C engine, which is fitted with four ABB TPL85-B turbochargers, develops 80,000 kW and sets new standards for environmentally friendly sea transportation. The installed WHR system delivers an additional maximum output of 8500 kW, which translates to a more-than-ten-percent reduction in fuel consumption and engine emissions at maximum continuous rating (MCR).

Finding the optimum design

While the operating cost reduction and environmental benefits of installing a WHR system are undisputed, shipbuilders must consider how de-

sign, operating and other parameters will affect profitability and payback for each individual ship. The preferred design depends on the type of vessel and its main operating conditions.

The required turbocharger efficiency for the specific ship also affects the WHR layout. The setup is greatly influenced by a) whether a turbocharger provides only the minimum efficiency a two-stroke engine requires for acceptable thermal loading of the engine components and for proper scavenging⁴⁾, or b) whether higher efficiencies are targeted.

Finally, there are economic considerations – the cost of the fuel, the investment cost and the size of the vessel's power plant with its indirect influence on the electrical energy generated by the WHR system. The payback time for WHR installations is shorter when it is used in combination with large diesel engines.

Matching of the main engine and the power turbine can be further optimized by replacing the standard fixed nozzle ring with variable turbine geometry (VTG). VTG allows the performance of the main engine to be improved; eg, by reducing the nozzle area for use in hot tropical areas **7**. Alternatively the turbine area can be increased at low ambient temperatures or at reduced vessel speed to maximize the power turbine's output.

The economic way to reduce emissions

ABB's calculations show that a significant reduction in CO₂ emissions is achieved with the stand-alone power turbine configuration. These reductions can even be doubled when a

7 Variable turbine geometry (VTG) allows optimal matching of the main engine and power turbine

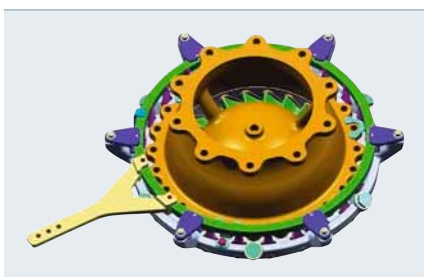

6 In April 2007 M/S EMMA MÆRSK was awarded "Ship of the Year" by Lloyd's List as one of the most environmentally friendly container vessels ever built



WHR system with a power and steam turbine is used.

The additional electrical energy for a large container vessel with a typical load profile would allow more than 2300 tons of fuel oil to be saved annually with the stand-alone arrangement and almost 5000 tons annually with the WHR system with steam cycle. In each case, the assumption is made that the additional electrical power is used to replace the power normally produced by the auxiliary diesel engines.

There are two types of WHR systems with power turbines for improving the fuel efficiency of a ship's main engine.

"Green ships" point the way forward

ABB's PTL power turbines address two of the most pressing issues in shipping today – fuel economy and environmental compliance.

While the direct economic benefits of fuel savings mainly depend on the development of fuel oil prices, the tightening of regulations for reduced emissions of vessels remains a major driving force for energy efficiency investments. The combined benefit of cost reduction and environmental

compliance will pay off for shipowners. As in other industries with increased environmental focus, the value of "green shipping" should not be underestimated.

Another strong inducement to invest in waste heat recovery could be economic instruments such as differentiated port dues and tonnage taxes, already in place in several ports around the world.

In the highly competitive environment in which shipowners operate, the combination of fuel-savings and emissions reduction make heat recovery systems with power turbines an attractive business proposition.

Markus Rupp

ABB Turbo Systems Ltd
Baden, Switzerland
markus.rupp@ch.abb.com

Footnotes

³⁾ TEU, or twenty-foot-equivalent-unit, is a unit that indicates the transport and storage capacity of ships and harbors, with one unit equivalent to approximately 38.5 m³.

⁴⁾ Scavenging is the expulsion of exhaust gases from the cylinder of an internal-combustion engine.

Further reading

Summers, M. ABB turbochargers – history and milestones. *ABB Review* 2/2007, 85–90.
Turbocharging in Switzerland (2005). *Turbo Magazine*, 2, 1–36.

The strongest link

Captive power plant-smelter interface for increased power plant efficiency

Max Wiestner, Georg Köppl

As aluminum smelters use vast quantities of electricity in the electrolysis of alumina and carbon, it makes sense to build them where electrical power is available at a reasonable price. Generating utilities like to have smelters on their grids as they provide stable clean loads. However, with increasing power demand, utilities are finding that they can no longer feed today's smelters from the grid and therefore co-generation is required. This means dedicated or "captive" power plants are now being built close to the smelter to supply it with the required power. But what if a smelter is located in a remote area where there is a weak or even no utility grid? Finding ways of successfully interfacing the power plant and the smelter has become somewhat of a challenge. The key to finding the most optimal interface solution involves meeting the requirements of both, and many of these are outlined in the following article.

Smelter potline power ratings have reached 600MW and utilities are under increasing pressure to meet the grid requirements of many smelter owners. The solution for many owners has been to install "captive" power plants. However, new smelter projects, with or without captive power plants, are often located in weak power grid locations, and interfacing the smelter and the power plant to ensure adequate power requirements are met is a very challenging task. Many issues such as power demand and fluctuations, power quality, potline start-up and trip need to be considered. Other critical issues include the power plant efficiency during normal operation or the consequences of a generation unit trip when it is in island operation mode. It is also important to note that load shedding with a diode rectifier only occurs at a maximum rate of 5MW/3 seconds.

Many smelter owners are now installing "captive" power plants because of the pressure utilities are under to meet the grid requirements of many aluminum smelters.

Meeting the requirements from both the smelter and power plant sides, as outlined in the **Factbox**, is key to finding the most optimal interface solution, which needs to be found very early in the project planning stage. In the long run, early optimization of the project design may reduce the capital investment cost of the power plant and smelter substation. An ABB develop-



Factbox Power plant and smelter requirements

The following points show interface issues that must be addressed to the power plant if the demands of the smelter substation are to be met. In particular, parameters that need to be defined include:

- Short Circuit Capacity (SCC) for all power plant operation conditions.
- The maximum allowable Total Harmonic Distortion (THD).
- Maximum possible power swings and rate (in MW).
- Maximum reactive/active power swing.
- The maximum allowable harmonic current loading of the cables.
- The power factor required.
- Maximum power (delta versus phase) unbalance.

Other points the power plant needs to consider include:

- Voltage dips are to be expected and allowed.
- Grid codes must be complied with.
- Second order harmonic current loading as large transformers are being energized.
- A generator synchronizing procedure and minimal block load must be specified.
- The variation in grid and island operation SCC is available on the smelter HV substation busbar.

The power plant must be able to cope with the following smelter issues:

- Power swings: Daily anode effects create a sharp 15MW power swing.
- The potline may trip more than 5 times in the first year (forcing a 600MW immediate drop).
- The potline initial start-up power demand increases by 3.5MW/day.
- A potline ramp-up of 20MW/min is the preferred restart rate after a trip.
- A power factor of 0.82 is required for a short time during restart.
- The voltage dips to 70 percent on the smelter bus when rectifiers are energized without synchronizing the feeder breakers.
- The higher the SCC, the lower the required efforts to meet power quality demands.
- If the maximum allowable THD is two percent, smelter tertiary filters are required if the SCC is less than ten times the smelter rating.

In the overall system design, the following smelter/power plant parameters must be considered:

- Is island operation required? If yes, a detailed study containing information about power flow, power quality and transient stability is needed.
- Diode rectifiers can only shed their load at a maximum rate of 5 MW/3 sec.

- Synchronized switching of transformers reduces power disturbances and voltage dips as well as mechanical stress on rectifiers and harmonic current filters. In any case the island mode of operation may not be possible without synchronized switching.
- GIS or AIS breakers must be able to switch between phases with an accuracy of ± 1 ms.
- To comply with the international standard IEEE 519²⁾, tertiary filters are required for the rectifiers in island mode.
- Harmonic current filters on the high voltage (HV) side may need to be studied as they are loaded with the harmonic currents, which may be in the grid.
- Power plant control systems need to be able to generate and send a high-speed load-drop signal.

Footnote

²⁾ IEEE 519 is the international standard that describes acceptable limits of harmonics in electrical systems.

ment known as Blackout Protection Control (BPC)¹⁾ also plays a critical role in ensuring stable smelter operation.

1 shows typical smelter voltage and current load curves that are seen by the power plant and which have to be considered in the overall system design.

2 shows the load that the smelter substation can shed with and without ABB's BPC. The diagram in **3** shows the smelter substation power quality versus the strength of the feeding grid. This must be considered should the grid be disconnected and for island operation to continue. Some of the big smelter power consumers, such as the Uninterruptible Power Supply (UPS), inverters and AC drives, are very susceptible to high harmonic current distortions. In **4**, the power factor of a smelter during initial start-up is shown. This

same power factor also applies after a potline restart. The design of the rectifier needs to be selected based on the power supply agreement as well as the power quality during such operations.

Voltage drops during rectifier energizing

Within captive power plant smelter systems, there may be some operation

scenarios where the power plant feeds the smelter in island operation. During these scenarios, the available SCC may be considerably reduced. As rectifiers become ever larger for these large smelters, their impact on the network during energizing is in turn quite substantial. **6** shows this impact with and without controlled energizing. The voltage dips may result in the tripping of already energized consumers, and may be very critical for captive power plant smelter projects. To be more specific, the medium voltage value may drop by up to 25 percent of the nominal rating, which is way beyond the allowed value of 10 percent.

Footnote

¹⁾ Information concerning ABB's Blackout Protection Control (BPC) is proprietary and will only be made available at a later stage.

1 Active power demand during potline trip and start-up



R&D focus

2 Load shedding capabilities of a smelter substation with and without ABB's Blackout Protection Control (BPC)

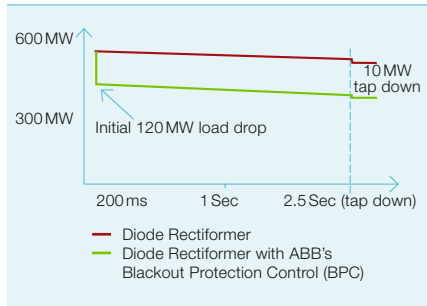

The following five case studies of captive or semi-captive smelters illustrate the wide variety of overall system designs and complexities that can be achieved. For these projects, ABB either supplied equipment or performed system studies.

ALBA, Bahrain

In recent years, Aluminium Bahrain (ALBA) experienced some blackouts that were attributed to a variety of reasons. Due to the mix in generation and five potlines, the de-energizing or re-energizing of the potlines is not so critical as load drops are smaller and can be shared by a high number of generating units. Therefore ALBA's operation mode is such that the smelter auxiliary consumers are operated on different grids to the smelter potlines, thus making the system immune to voltage dips or load drops.

DUBAL, Dubai

Dubai Aluminum (DUBAL) has a large number of potlines. Some are rated at less than 100MW and have a good mix of generation. Therefore the grid can easily compensate should one potline trip. In addition, the large number of potlines as well as their low power rating have an easier effect on the power quality level, as the harmonic currents are compensated for with a multi-pulse operation. Start-up power demand and load rejection are of no con-

3 Power quality versus grid power strength

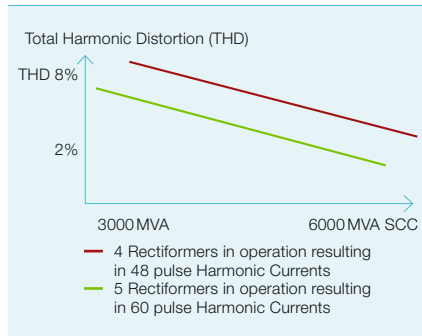

cern, and auxiliaries are fed from a different grid supply.

Nordural, Iceland

The Icelandic grid is becoming increasingly stronger. However, most of the

power generated comes from low inertia geothermal steam turbines and from the non-industrial power demand fluctuations between day and night. Aluminum smelters create an ideal load. The large daily change in grid stability requires a very flexible smelter substation design to allow for high-speed load shedding and the highest power quality performance. Due to this requirement, Nordural decided to use tertiary filters on the regulation transformers as well as thyristor rectifiers for high-speed load shedding. The highest power quality has been achieved by control switching the rectifiers as well as the tertiary filters **5**.

Fjardeel, Iceland

This single 500MW potline smelter will be fed from a captive hydro

power plant is located approximately 60 km away. A weak 132kV grid inter-connection is possible at the power plant substation. The auxiliary power for the smelter will be taken from the same power lines feeding the smelter rectifiers. Should the potline trip, the power plant will be idled because the Icelandic grid will not be able to take the extra power. The available SCC has to be considered low to very low during initial start up and normal operation.

4 Power factor during potline start-up

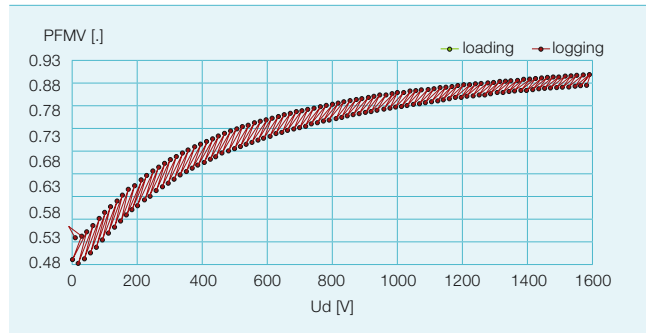

5 Switch synchronization at the Nordural (Iceland) plant

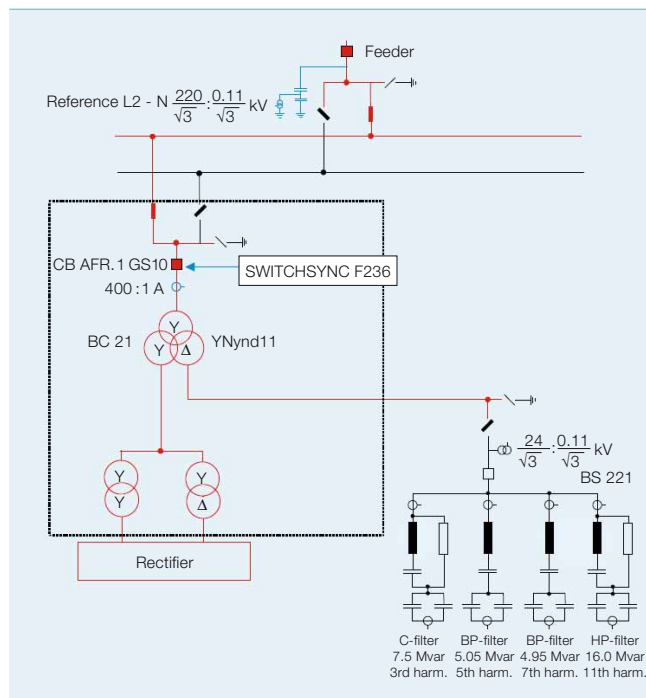

Sohar, Oman

This new smelter is designed to accommodate up to three 550MW potlines and is fed from a captive combined cycle power plant. A 220 kV grid inter-connection is possible at the power plant substation and the distance between the power plant and the smelter is approximately 12 km. The auxiliary power for the smelter will be taken from the same power lines feeding the smelter rectifiers. As in the previous case study, if the potline trips, the power plant will need to be idled, and the available SCC must be considered low to very low during initial start-up and normal operation.

Final thoughts

With an available SCC of 2500 MVA from a power plant and a 600 MW smelter load, the corresponding ratio of four represents a very weak system – a ratio of 10 or higher is preferable. It is therefore estimated that if one gas turbine were to trip at the power plant this would in turn trip the smelter. Diode rectifier systems cannot shed loads, and island operated Gas turbine (GT) power plants may trip on under-

frequency in less than two seconds. To avoid this, a “dummy” load may be required, which would protect the power plant from being completely disconnected in the event of a potline trip, and allow the smelter to start. There are two possible ways to protect the smelter from tripping after a GT trip:

- The power plant is designed such that the smelter load ramp and trip can be followed (ie, using ABB's BPC).

- The smelter is equipped with thyristor rectifiers which allow immediate load shedding.

The key to finding the most optimal interface solution between a power plant and a smelter involves meeting the requirements of both.

6 Voltage dips on the medium voltage power energizing transformers, with and without controlled switching

a Inrush regulating transformer

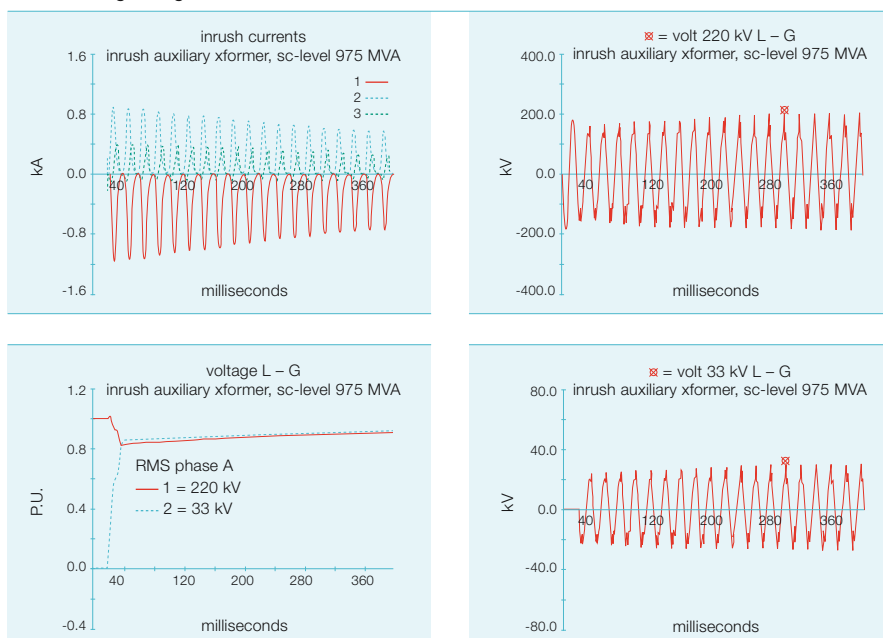

b Inrush regulating transformer with synchronized closing

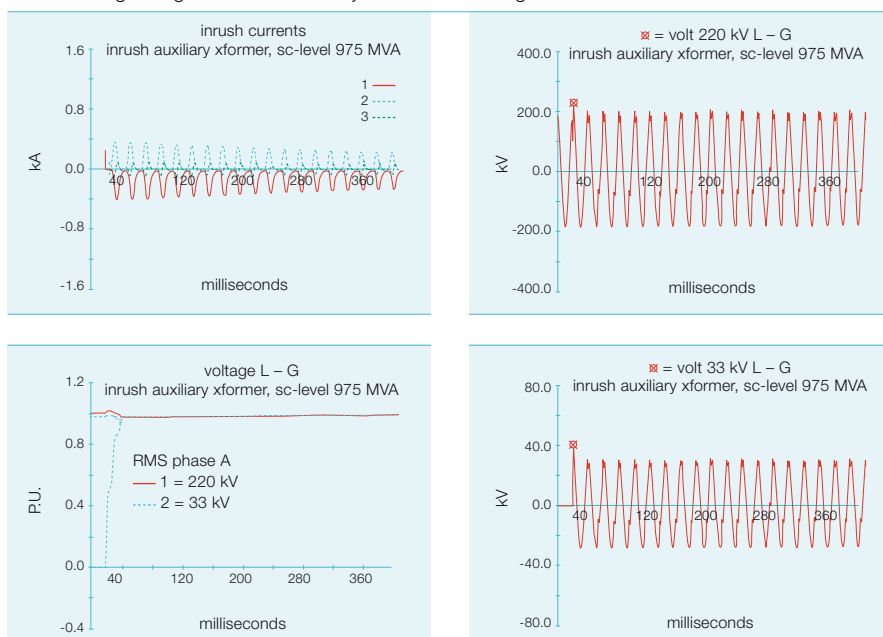

If a total harmonic distortion (THD) of two percent or power factor correction to 0.98 is required, and the power contract is such that a high power factor is always needed, then harmonic current filters connected to the regulating transformer tertiary is the most economical method. This method is also required if the power system is weak. Synchronized switching should be used on the filter banks to reduce inrush current stress and over-voltages. Nordural's (Iceland) new converter station is the most advanced in this respect with:

- A full range regulation transformer with tertiary filters, which always allows for the most optimal power factor
- Thyristor rectifiers that follow the grid power capabilities
- Synchronized switching of transformers and filters for (a) minimal network distortion in a very weak grid and (b) minimal stress on filters, switchgear and transformers.

Max Wiestner

ABB Switzerland, Primary Aluminum
Baden-Dättwil, Switzerland
max.wiestner@ch.abb.com

Georg Köppl

Power consultant to ABB

Reference publications

- Metal Events Conference, Reykjavik Iceland 2004
- Metal Bulletin Conference, Oslo Norway 2004
- Metal Events Conference, Muscat Oman 2005
- Aluminium World, Bahrain Feature 2006/1
- Metal Events Conference, Dubai UAE 2006

More muscle, less waste

ABB's workout program realizes sustainable energy savings and reduces costs in process plants

Jim McCabe

Maintaining the good health of a process plant is prime to securing its long-term profitability. With concerns over energy prices on the rise, operators are finding that it pays to invest in ways of slimming their consumption. But what is the best way to optimize efficiency?

Wasted energy can take many forms. These can include such widely different causes as inadequate scheduling and planning, suboptimal setpoints in control loops or inappropriate or incorrectly used equipment. It is often accentuated by leaks or the inadequate lagging of boilers and pipes.

ABB's Energy Improvement Program is designed to identify and deliver energy savings in process plants, achieving sustainable savings of up to 20 percent.



In the face of fluctuating fuel prices and tightening legislation on emissions, reducing energy consumption and greenhouse gas emissions are two of the biggest concerns affecting companies in the process industry today. Energy and utility systems provide manifold opportunities for savings – especially when it is the entire system rather than just some individual sub-systems that are available for scrutiny. Considerable potential for savings is possible by reducing the consumption of process utilities (such as steam, chilled water and compressed air), minimizing distribution losses and improving generation efficiency. In fact, a successful implementation of these measures can yield up to 20 percent reduction in energy consumption.

But what is a successful implementation? The dangling carrot of potential benefits is only part of the equation. An informed decision on optimization must weigh such gains against the costs and possible risks.

Enter ABB

Energy is a fundamental ingredient in almost any manufacturing process. In a process plant, the principal means of delivering energy are electricity and the process utilities mentioned above. As energy represents an increasing proportion of the operating costs of many companies, the focus of optimization is increasingly shifting towards these utilities and where they are consumed in the production process.

Drawing on years of experience in process operations, ABB Engineering Services supports plant operators in their efforts by identifying improvement opportunities and implementing a program to make sure these benefits are delivered – and this as quickly as possible. More than 50 companies around the world have already benefited from this support. In such a program, ABB's experienced energy and utilities consultants apply a structured process to assess the overall potential of energy savings at a manufacturing site before developing and implementing energy conservation projects **1**. As well as the huge energy savings that were attained in these projects, many companies have through this process acquired the skills and motivation necessary to develop their own sustainable improvements in energy efficiency.

The dangling carrot of potential benefits is only part of the equation. An informed decision on optimization must weigh such gains against the costs and possible risks.

Identifying opportunities

An efficiency improvement process begins with an overview of the site's energy balance and an assessment of the savings potential. All aspects of the energy chain are considered; from utility generation through distribution

to consumption. Improvements can range from low- or no-cost "quick wins" to the implementation of energy efficient technologies. Quick wins may involve simple housekeeping activities such as maintaining insulation and repairing leaks or may require more fundamental challenges to "the way we've always done it"; eg, turning off main plant items instead of keeping them running, or challenging the set points of process control loops in utility distribution temperatures, pressures or flowrates.

When it comes to efficiency-boosting technologies, numerous options are available: These range from variable speed drives to advanced process control. The larger challenge lies in identifying which of these are suitable for the situation in question – and this requires a careful analysis of benefits and risks. Benefits are usually related to the delivered energy savings but may include other non-energy related advantages such as improved reliability or increased capacity.

ABB frequently receives praise from its customers for the pragmatic nature of its analyses. In the words of the director of a UK ingredients company, "We've had no end to audits that either tell us to turn the lights off or invest millions of pounds. What I like about [ABB's] approach is that [they] concentrate on the practical."

The practical approach

A preliminary audit carried out for a European chemicals manufacturer **2**

1 The steps of an energy efficiency improvement program

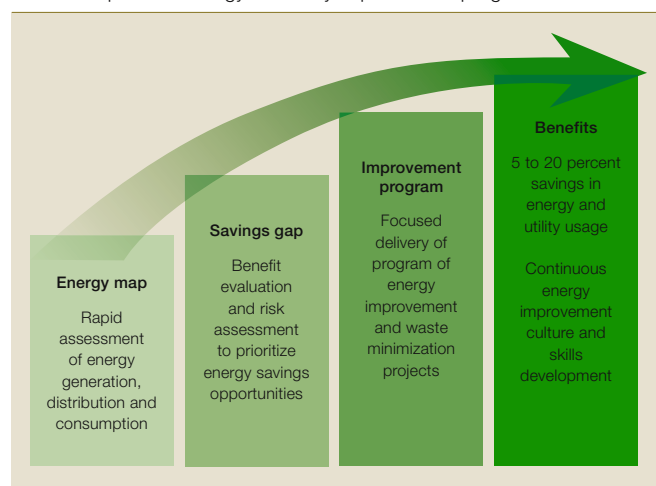

2 A preliminary audit carried out for a European chemicals manufacturer predicted savings equivalent to ten percent of the total site utility costs



R&D focus

predicted savings equivalent to ten percent of the total site utility costs. The following section investigates in more detail how this figure was achieved.

To start, numerous opportunities for utility cost reduction were identified during a review of the site's energy consumption. A benefit and risk analysis narrowed these down to four priority areas: tariff management, steam distribution, heat recovery and the application of variable speed drives.

Tariff management

ABB engineers observed that during the winter months, the electricity supply tariff structure for the site included a very high rate for a period of three hours every day. The total cost of electricity consumed during these three hours was equivalent to that consumed during the rest of the day. Significant savings potential at no capital cost were identified by scheduling production to minimize the operation of processes with high electrical demand during this period.

A further interesting savings potential was obtained in the area of two 160kW pumps for cooling water. These are backed up by diesel-driven pumps. The spare pumps were tested for two hours every week and this test occurred outside the high-cost electricity period. It was shown that rescheduling the test to coincide with this peri-

od had the potential to save £3,000 per annum. Increasing the operating hours of the diesel pumps to cover the high-rate period five days a week could deliver annual savings of £14,000.

Steam distribution

Steam leakage was reduced by improved maintenance of steam traps. Overall steam consumption was furthermore reduced through enhanced heat recovery. Heat exchangers using the hot effluent from a steam stripping column to preheat the feed to the column were found to be undersized with the result that not all of the available heat was being recovered.

A preliminary audit carried out for a European chemicals manufacturer predicted savings equivalent to ten percent of the total site utility costs.

Variable speed drives

Engineers found that slurry pumps and air fans around the drying plant were oversized: In many cases they were operating at less than half their nominal load. Such situations are an ideal application area for variable speed drives. These can reduce the energy consumed by the pump and fan motors by as much as 60 per cent¹⁾.

A successful project

In another example, a specialized chemical manufacturer ³ required reliable low-temperature refrigeration capacity for the manufacturing of several key products. As the cooling capacity of the installed refrigeration system deteriorated, production volumes were limited and energy efficiency was reduced because it was necessary to run two compressors instead of one.

The original installation comprised two reciprocating compressors (one operating, one standby) with R22 as the primary refrigerant, an oil separator, a throttle valve and evaporator with an oil rectification system, and an additional oil separator. The system was designed to operate at temperatures down to -48°C.

ABB carried out a detailed review of the process and mechanical performance issues. Following plant trials and data analysis, the problems were traced to mechanical faults and heat exchanger fouling. Cleaning these exchangers immediately increased plant capacity. ABB also specified mechanical modifications for phased implementation in order to prevent future fouling. In the final phase of the improvement program, an up-rated heat

Footnote

¹⁾ See also Wikstroem, P., Tolvanen, J., Savolainen, A., Barbosa, P., Saving energy through drive efficiency, *ABB Review 2/2007*, 73-80.

3 Fine chemical plant: Energy optimization methods permit significant cost savings



4 Time-dependent steam demand profiles for different production buildings in a multi-product batch (fine chemical or pharmaceutical) plant

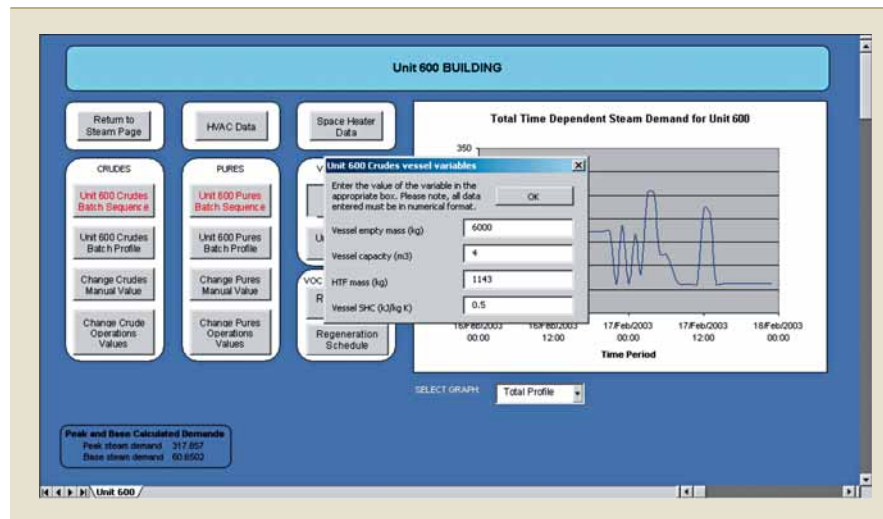

exchanger was installed to increase the capacity of the refrigeration system.

The improvements to the refrigeration capacity have allowed shorter batch cycle times and increased production rates and reaction yields. Refrigeration system reliability has also improved and the use of a single compressor has delivered energy savings to the tune of £48,000 per annum.

Targets and improvements

As with any improvement program, it is important to be able to set performance targets and verify progress against those targets. As the program is developed, the scope, budget, timescale and expected returns for each energy conservation project are agreed upon with the client and a means of performance verification is put in place. When possible, an energy management system is installed including metering, data collection and analysis.

Setting the right improvement targets is a key element of most energy efficiency programs. If goals are unachievable, the motivation for improvement is quickly lost. On the other hand, unambitious targets compromise cost and emissions reduction. The problem is particularly acute for operators of plants in which utility demands are strongly time-variant; for example, batch production of fine chemicals or pharmaceuticals. In such facilities, the load profile of the utility infrastructure will vary from hour to hour and from day to day, depending on the mix of products and the specific cycle time, and the utility requirements of each batch. There is no straightforward answer to the question "how much utility?" in multi-product plants. This makes setting effective targets a tough challenge.

Targets are often based on historical energy and utility consumption, an approach referred to as Monitoring and Targeting (M&T). One weakness of this approach is that it is highly dependent upon the quality of the input data, and in particular the conditions when the historical data was collected. A steam trap may have been passing or there may have been

a significant leak from a compressed air line during the data collection period. Because these inefficiencies are not apparent from the data, this inefficient performance becomes the baseline for future comparison. In addition, M&T does not take the capacity of the current utility infrastructure into account and cannot identify bottlenecks in the utility distribution network.

Minimum Practical Energy is a robust method used by ABB to determine benchmarks for energy and utility consumption and to set improvement targets based both on sound theory and real production schedules. Areas where actual energy use is significantly different from the minimum practical requirement – eg, where a process is consuming more steam than expected – are identified quickly. This allows improvement targets to be pinpointed and provides a basis for tracking performance against the target. The demand profile for a particular production slate is compared to the capacity of the utilities infrastructure, highlighting bottlenecks and allowing the utility plant to be operated for maximum efficiency. Careful scheduling can reduce peaks in utility demand and eliminate the need for capital expenditure.

Setting the right improvement targets is a key element of most energy efficiency programs.

ABB has used this concept to identify annual savings of around £100,000 for the operator of an active pharmaceutical ingredient (API) plant. A simulation model of the utility infrastructure calculates the minimum practical energy requirement. Mass flows and pressure drops are rigorously modeled throughout the site distribution networks for each fluid utility (eg, steam, compressed gases and water). The dynamic utility system model predicts flows, pressures and velocities based on the time-dependent demand profile arising from the daily activities in each unit. Production and non-production areas such as reservoirs, effluent plants and electricity for offices

and canteens are included in the analysis.

The utility demand can be entered manually for each unit operation – heating or cooling, mixing or adding reactant – or calculated from the sequenced activities in the batch recipe. Individual batches can be combined to simulate a complete production schedule, and the demand profile calculated over a time period lasting from one day to five years. Climatic data are also incorporated to account for the demand from space heating or air conditioning.

This model of expected utility demand is compared with the known capacity of the utility systems, facilitating the identification of instantaneous or sustained capacity constraints. Process-control schemes for the utility systems can be incorporated, allowing different utility sources to be brought online to meet demand fluctuation. The simulation allows the operator to predict the level of utility required to meet the production schedule – for instance, how many boilers need to be fired at any one time. Future production schedules can be optimized to minimize excessive fluctuation in utility loads and to prevent them from creating peak demands that exceed utility system capacity. The model also allows the user to identify areas where the actual energy and utility consumption exceeds the minimum practical energy value and hence identify opportunities and targets for future energy conservation efforts.

The ABB Energy Improvement Program is a structured process with well-developed tools that identify and deliver energy savings to operators of process plants while they concentrate on core activities. Participating companies can realize savings of up to 20 percent of energy costs and develop their own capability to make sustainable improvements in energy efficiency.

Jim McCabe

ABB Engineering Services
Daresbury Park, UK
jim.mccabe@gb.abb.com

Wireless detection

Embedded system technologies in wireless motion detectors

Olivier Steiger, Richard Bloch , Beat Kramer,
Daniel Matter, Philippe Prêtre , Christian Heite

Motion detectors have become ubiquitous in homes and workplaces across the globe as a form of protection, and as a means of triggering light sources indoors and out. However, these detectors need wires to function, making their installation laborious as well as costly. The good news is that this is all about to change. ABB, in cooperation with one

of its partners, has recently developed a new wireless motion detector. Using embedded system technologies, not only have the wires disappeared but engineers have produced a flexible, reliable, compact and inexpensive device that can operate for at least five years using just standard alkaline batteries!



Busch-Jaeger, an ABB company, offers a broad range of motion detectors for use in homes, offices and outdoor environments. These *Busch Watchdogs* are characterized by their high reliability and innovative design. However, in some cases the installation effort required, especially in existing buildings where no extra cabling has been placed, can be quite high. Therefore, to reduce this effort as well as allowing for additional placing freedom, Busch-Jaeger, working together with ABB's Corporate Research Center and another company MEMS Inc.¹⁾, has developed a new wireless motion detector **1**.

Low power consumption was one of the fundamental demands of the new wireless motion detector, and it had to be provided without compromising reliability. This demand was met using low power-consuming components and embedded system technologies. Electromagnetic susceptibility, which increases with a rise in system impedance, had also to be addressed. To avoid this, all sensitive signal lines were kept short. So, not only have the cables disappeared making installation easier, but the end result is a reliable and inexpensive motion sensor that consumes, on average, less than 20 μ A of current! In addition, it allows for

1 The new wireless motion detector excels through its high reliability and innovative design



seamless integration into the existing Busch-Jaeger product portfolio in terms of cost, design and performance.

ABB's wireless motion detector uses embedded system technologies, is flexible, reliable, compact and inexpensive.

Detector design

To carry out the different functions of the detector, three interconnected modules have been developed – the sensor, radio and controller modules.

The sensor module

This is the most delicate part of the system as it contains the passive pyro-

electric infrared sensor (PIR) **2a** that captures the monitored movements, and transforms them into infinitesimal electrical signals. Because small signals are particularly prone to electromagnetic interferences, they need to be amplified as close to their source as possible. Therefore, an ultra-low power amplifier **2b** has been mounted directly beside the PIR sensor connections. The sensor has been taken from the Busch Watchdog Professional product series and adapted to the stringent power

consumption requirements of the new device.

The radio module

The radio module ensures communication between the wireless motion detector, and one or several actuators (ie, radio-controlled light switches). To fulfill the low power consumption requirements in this module, only one-way communication from the motion detector to the actuator is used to avoid permanent reception readiness. A typical transmission takes place in the ISM-Band (Industrial,

Footnote

¹⁾ MEMS Inc. is an engineering company whose founding members are former ABB research engineers. For further information see www.memsag.ch (September 2007).

2 On the sensor module, the amplifier and the PIR sensor have been mounted in a way that avoids electromagnetic interferences

a Front fitted with PIR sensor

b Back with electronics and amplifier (these pictures taken during production show several sensors)

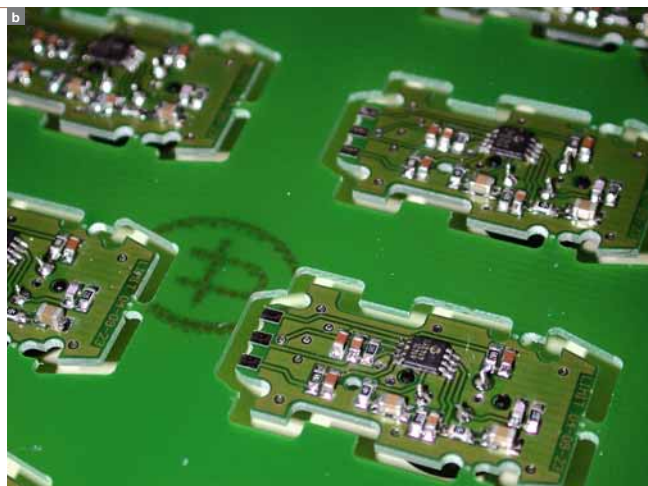
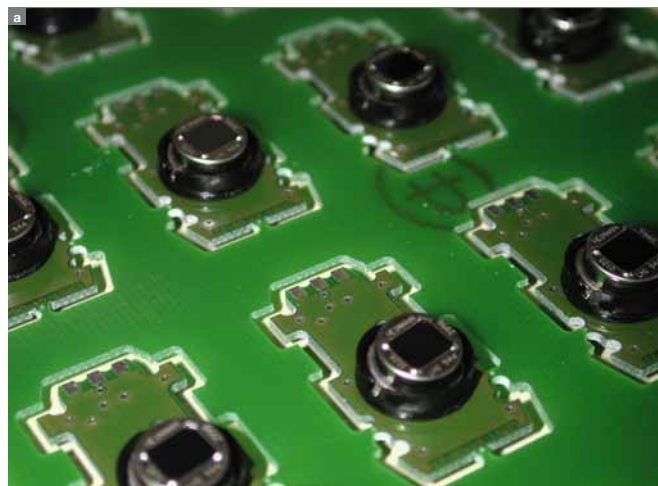

R&D focus

scientific and medical) at 868 MHz (KNX-RF protocol), and a range of up to 300 meters is possible out in the open.

The controller module

The radio and sensor modules are mounted on the controller module ³. This module also contains a power supply and provides the means for background illumination sensing and parametrization. Its core component is a mixed-signal microcontroller that processes all sensor signals and system parameters, finally generating the binary presence signal that is transmitted to the actuator by the

radio module. The microcontroller supports several power down modes that allow the temporary shutdown of individual processor functions, and their subsequent recovery within a few microseconds. By operating only the necessary circuitry needed to perform a particular function, additional – in fact substantial – power savings are achieved.

Finding an appropriate power supply

Ultimately, the success of a wireless appliance depends as much on its innovative design as it does on the choice and availability of an appropriate power supply. Users demand en-

ergy sources that are cheap and compact, and which function for a very long time. Therefore, a variety of power supply solutions were investigated as to their suitability in a wireless motion detector. Some of the criteria that had to be met included:

- A potential source should function uninterrupted for at least ten years.
- It must be able to deliver an average current of 20 µA and sustain current peaks of 25 mA. These typically occur during radio communications.
- The temperature range should extend from at least –20 to +60°C.

Six possible candidates are listed in the **Factbox**.

Factbox Power supply possibilities for the wireless motion detector

Power supply	Source of energy	Suitability
Batteries	Electrochemical	Suitable
Solar cell	Sun	Suitable
Thermoelectric generator	Temperature difference	Possibly suitable – Low performance
Fuel cell	Electrochemical	Not suitable – Expensive, limited long-term stability
Piezoelectricity	Wind (von Karman effect)	Not suitable – Very low performance
Wireless energy transfer	Power supply system	Not suitable – Expensive, acceptance issues

Batteries

Batteries constitute the most obvious solution. Four 1.5 V alkaline cells ensure a lifespan of five to seven years, just a little short of the ten year goal. Moreover, this option is very cheap and batteries can be acquired virtually anywhere. The downside, however, is their limited temperature range²⁾ and self-discharge rate, which happens to be quite significant. To overcome these disadvantages, the more expensive but longer lasting lithium iron disulphide cells (Li-FeS₂) could be used instead.

Users demand energy sources that are cheap and compact, and which function for a very long time. Therefore, the success of a wireless appliance also depends on the power supply used.

Solar cells

A power supply based on solar cells is ideal for the wireless motion sensor. Solar cells constitute an ecological alternative to a battery supply. They require no maintenance or replacement and are particularly suited for

³ Controller module fitted with three sensor modules and one radio module

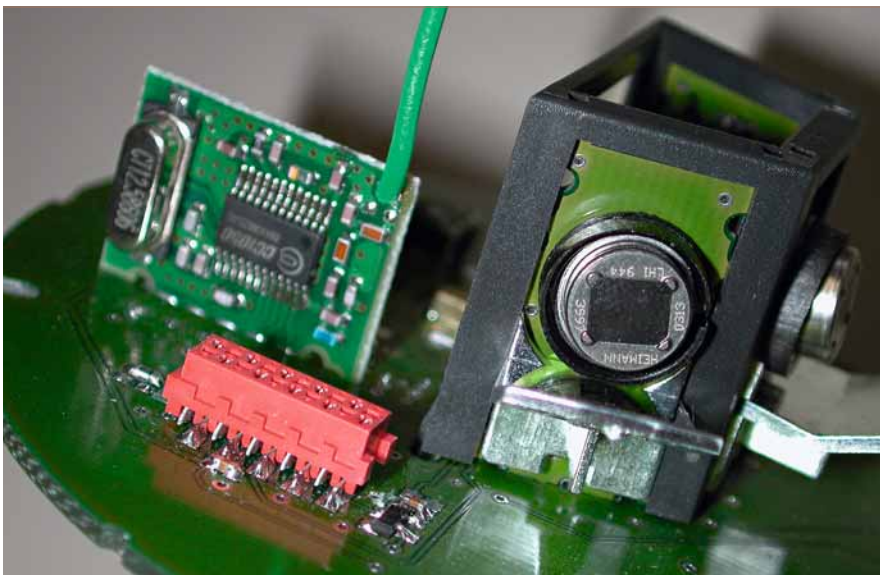

Footnote

²⁾ The typical temperature range for alkaline batteries extends from –10 to +50°C, while it can range from –40 to +85°C for Li-FeS₂ cells.

self-sufficient working. In fact, a solar cell-based power supply prototype for the wireless motion detector has already been designed by ABB engineers. Photovoltaic cells produce most of their energy during daylight, and therefore some energy storage is required for night operation. This principle is illustrated in 4: The electric double layer capacitor (EDLC), C1, stores the energy generated by the solar cell during the day. These capacitors, also known as Gold Caps, deliver energy densities that are 300 times that of conventional capacitors. They can be recharged hundreds of thousands of times, unlike conventional batteries which last for only a few hundred, or at most a thousand, recharge cycles. However, loading the EDLC can take several hours. Therefore, another smaller capacitor, C5, is normally connected in parallel to reduce the initial start-up time of the powered device.

The solar cells consist of amorphous silicon. This type is much cheaper than crystalline cells, and its effectiveness does not depend on even illumination. This is important because motion sensors are often operated in partially shaded locations. With the above solution, a cell of size 57×50 mm suffices to reliably power the wireless motion detector.

Thermoelectric generators

Thermoelectric generators use the Seebeck Effect to create power from temperature differentials. The Seebeck Effect is defined as the open circuit voltage produced between two points on a conductor, where a uniform temperature difference exists between those points. This effect is usually very small, but recent generators have achieved as much as 20 μW on a single chip with a temperature difference of 5°C. In order to apply the thermoelectric principle to the wireless motion detector, a sufficient temperature gradient must be attained inside the device. While solar energy could be used to this end, thermoelectric generators are not yet suitable for indoor applications.

4 Principle of the solar cell supply. Solar cells produce power during daylight, and additional energy storage for night operation is provided by C1 and C5

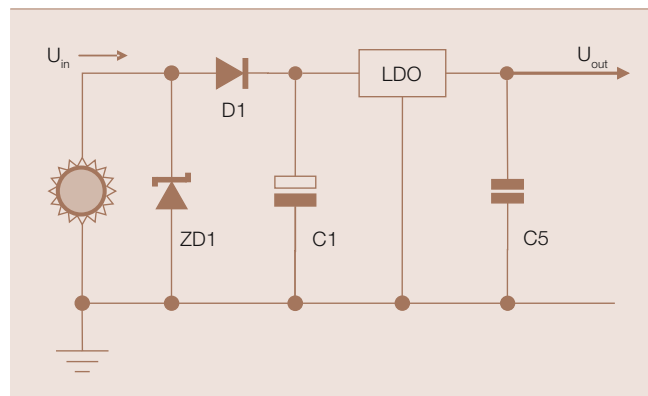

Fuel cell

A fuel cell is an electrochemical device similar to a battery, but it is designed to continuously replenish the reactants consumed. In other words, while a battery has limited internal energy storage capacity, the fuel cell produces electricity from an external fuel supply of hydrogen and oxygen. Research has shown that the development of fuel cells for portable computers and cellular phones is possible, but high costs and a limited lifespan currently prevents their use in wireless motion detectors.

The wireless motion detector combines the well-established reliability of Busch Watchdogs with ultra-low power consumption, and it can be placed anywhere and is easy to install.

Piezoelectricity

With piezoelectricity, certain crystals generate a voltage in response to an applied mechanical stress, for example one generated by wind or by any other form of thermal airflow with the aid of the von Karman effect. This principle, which notably describes the flapping of a flag, states that flow around a bluff body will generate vortices on alternate sides of the body. The effectiveness of this method however is insufficient for powering the wireless motion detector.

Wireless energy transfer

Wireless energy transfer works by transmitting electromagnetic energy from an external power source to the receiver. This would require the mounting of an expensive and space-consuming emitter coil in the actuator. In any case, customer acceptance of such technology is still low.

Where customers benefit

The wireless motion detector developed by ABB combines the well-established reliability of Busch Watchdogs with ultra-low power consumption. It can be placed anywhere and is easy to install. Normal off-the-shelf alkaline batteries ensure a lifespan of at least five years, and this is extended to more than ten years when lithium iron disulphide cells are used. The detector complies with all current EMC regulations.

The wireless Busch Watchdog³⁾ was successfully presented at the "Elektrotechnik" fair in Dortmund, Germany in September 2007.

Olivier Steiger

Richard Bloch

ABB Corporate Research
Baden-Dättwil, Switzerland
olivier.steiger@ch.abb.com
richard.bloch@ch.abb.com

Beat Kramer

Daniel Matter

Philippe Prêtre

MEMS AG

Baden-Dättwil, Switzerland
beat.kramer@memsag.ch
daniel.matter@memsag.ch
philippe.prêtre@memsag.ch

Christian Heite

Busch-Jaeger Elektro GmbH
Lüdenschied, Germany
christian.heite@de.abb.com

Footnote

³⁾ More detailed product information can be found at <http://www.busch-jaeger.de/de/bewegung-smelder/1836.htm> (September 2007)

100 years

ABB celebrates a century of presence in China

Franklin-Qi Wang



ABB's relationship with China dates back to 1907, when it delivered the country's first steam boiler. Today ABB has established a full range of business activities in China, including R&D, manufacturing, and sales and service, with more than 12,000 employees, 25 joint ventures and wholly owned companies, and an extensive sales and service network across 38 cities. In 2006, total orders in China rose to \$3.1 billion with revenues of \$2.8 billion, turning China into ABB's number-one market in terms of revenues.

PERPETUAL PIONEERING

The ABB Group uses its more than 100 years of experience in electrical engineering to pioneer processes for the power and automation industries. Many ABB companies in China are best in class, setting benchmark standards for their peer groups, while serving a wide range of industries.

In 1974, ABB's China operation was established in Hong Kong. This was followed by its first permanent office in Beijing in 1979. In 1994, ABB decisively moved its China headquarters to Beijing, and in 1995, ABB's holding company, ABB (China) Ltd., was formally established ¹.

ABB's product portfolio in China includes the full range of power transformers and distribution transformers; switchgear technologies for high-, medium- and low-voltage applications; electrical drives and motors; and industrial robotics products. These products are widely used now in industrial, commercial and utility applications.

In China, ABB has participated in many key state projects, such as the Three Gorges power plant and its power transmission to Shanghai, Changzhou and Guangdong ²; the south-to-north water diversion project; and many projects in connection with a major international sports event in 2008, including stadium constructions ³, the Beijing International Airport expansion, and substation and metro construction.

In addition, ABB also provided power equipment to Lianyungang Nuclear Power Plant, water quality monitoring and analysis systems to Chinese environmental authorities, and power and automation technology solutions to

Asia's largest petrochemical complex (SECCO) in Shanghai, the Great Hall of the People, Shanghai and Guangzhou Metro, Shanghai GM, Baosteel, and others.

In 2003, ABB was rated one of the top ten employers in China via the survey conducted jointly by Fortune Magazine, Yahoo and other organizations. In early 2006, ABB (China) Ltd. was rated one of the ten "favorite employers" by university students in China.

ABB has committed to helping China achieve its goal of energy efficiency and environmental sustainability.

Localizing operations

With a commitment of long-term development in China, ABB has steadily been transferring more businesses and

technologies to the country to expedite its localization process and provide products that better meet customer demands, shortening the delivery cycle and improving its technical service capabilities.

In March of 2005, ABB opened a Corporate Research Center in Beijing with a branch in Shanghai, a concrete step forward to understand, foresee and support China's future in the power and automation industry. As an integral part of ABB's global research network, the center in China is focused on power transmission and distribution, manufacturing and robotics. In early 2006, ABB moved the headquarters of its global robotics business to Shanghai, reflecting market trends and the strategic importance of the company's operations in China. ABB has also established research teams in each business division in China to maintain its leading position in the market. In addition, each ABB enterprise in China has a technical team to cater to the needs of local markets.

Three Gorges Lake



¹ Timeline of ABB in China

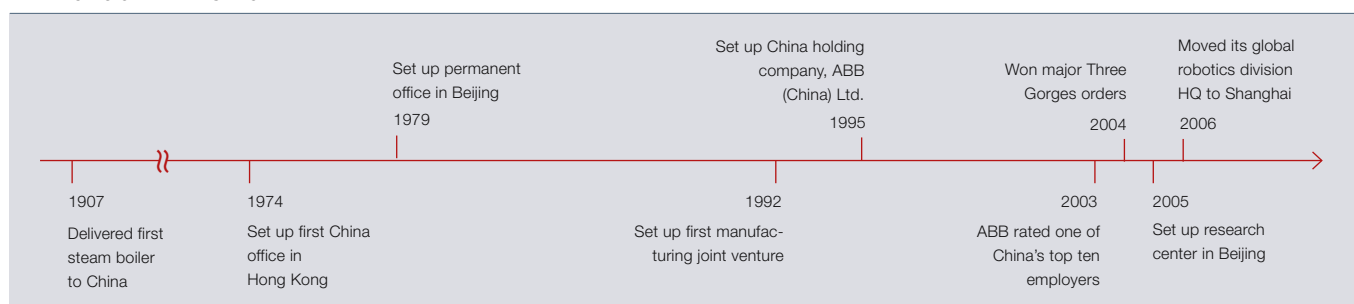

PERPETUAL PIONEERING

2 Three Gorges Dam



At present, ABB's Powertrain Assembly global lead center, ABB Asia Metals, and Center of Excellence for Processing Lines and Tube Rolling Mills are both located in Shanghai.

Over the years, ABB has developed a close relationship with key government ministries and major customers. In China, as well as in the global market, ABB aims to be a supplier that helps customers achieve their business goals. The company's ability to accomplish this derives from the intimate understanding of its customers' businesses, the ability to anticipate changing needs and shifting market demands, and to deliver innovative products and complete system solutions in the fastest possible way, including financing and strong after-sales service support.

Continuous improvement in customer satisfaction has become a way of life. ABB is working to set up more operations in China to provide customers with a broader range of advanced, energy-efficient, reliable and environmentally friendly products and services.

ABB's technologies in China

Energy efficiency is a priority on

China's current agenda. As the world's fastest growing economy, China is increasing its power capacity while using power more sparingly. Its 11th five-year plan highlights the importance of energy efficiency in building a resource-efficient society in China. ABB has committed to helping China achieve its goal of energy efficiency and environmental sustainability¹⁾.

With a commitment of long-term development in China, ABB has steadily been transferring more businesses and technologies to the country.

Efficient power transmission

HVDC (high-voltage direct current), pioneered by ABB in 1954, is a cost-effective and environment-friendly technology for bulk transmission of electricity over long distances with low power losses. In China, ABB has built three HVDC lines, each about 1000 km long. The savings achieved with each line, as compared to AC transmission, corresponds to the con-

sumption of about 160,000 households.

ABB i-bus intelligent installation system

ABB i-bus intelligent installation systems meet the highest requirements for applications in modern home and building control while offering substantial reductions in power consumption. For instance, an ABB i-bus EIB system helped one of Ito Yodado's stores in Chengdu save about \$250,000 on its power bill upon one year of operation.

Cutting-edge turbocharging technology

ABB is the world's leading supplier of turbochargers for large diesel engines used in ships, power plants and locomotives. ABB's turbochargers have raised the bar for engine output and efficiency, thus reducing power consumption and environmental impact. Customers in China and all over the world rely on ABB's first-class turbocharger service provided by a network of more than 86 service stations around the globe.

Energy-saving drives

Energy-efficient drives ensure that motors run in the most efficient way



in each application. ABB's total installed base of AC drives is estimated to save about 100 million MWh of energy per year worldwide. In China, ABB's drives have saved ten million MWh of power in the past ten years –

Factbox Remarkable contracts in China

- \$390 million for the Three Gorges-Shanghai HVDC project, the world's largest power transmission project in 2004
- \$360 million for the Three Gorges-Guangdong HVDC project
- Electrical equipment for metro systems and light rails in Beijing, Shanghai, Guangzhou and Tianjin
- \$40 million to supply process automation, drive, quality control and electrical systems and related services for Asia Pulp & Paper in China
- \$24 million to supply hoist equipment for eight mines of Huainan Mining Group
- \$60 million to supply one 500 kV gas insulated switchgear (GIS) and 12 power transformers for the Right Bank Power Plant at Three Gorges
- \$11 million to supply high-voltage GIS for the Phase II project of Jiaying Power Plant in Zhejiang Province
- \$200 million from Shanghai SECCO Petrochemical Company to provide an innovative propylene process technology that cuts energy consumption and reduces greenhouse gas emissions; it is the first time this technology has been used in China
- \$56 million to provide automation equipment and electrical systems for a high-efficiency steel mill to be built by Zhangjiagang GTA Plate Co.

equivalent to two years' power output from a nuclear power plant.

High-efficiency motors

Electrical motors consume about 65 percent of the total electricity used in industry. The efficiency level of ABB's motors sold in China is 1.5 to 2 percent higher than the average, thus greatly reducing power consumption. ABB's motors help save 1500 MWh of power in China each year.

Advanced marine propulsion system

In Aug 2005, ABB celebrated the delivery of China's first independently designed 3000-ton research and exploration vessel. Equipped with ABB's Compact Azipod® propulsion system, the vessel consumes 10 to 15 percent less fuel than comparable vessels without Azipod®. ABB's Compact Azipod® propulsion system also powers the three vessels in the new train ferry line between Yantai and Dalian with corresponding fuel savings.

Business achievements

ABB's contribution in China has been recognized by the country's important figureheads. In 1999, China's former president Jiang Zemin visited ABB's facilities in Switzerland. In 2004, China's vice premier Zeng Peiyan paid a visit to ABB's Corporate Research Center in Switzerland, and in 2007, Chinese President Hu Jintao visited the ABB Chongqing Transformer factory.

ABB has a long track record in China, having earned a number of remarkable contracts **Factbox**.

The commitment to China

ABB remains committed to China, and

to the long-term sustainable development of the country. Chinese utilities continue their expansion plans at an expected growth rate of eight to ten percent of the Chinese economy. In the period up to 2011, \$335 billion is earmarked for major projects in rail, wind, oil, gas and water infrastructure.

Industrial production also is expected to grow strongly. The steel capacity alone will increase by 45 percent to 600 million tons by 2015. The industrial sector is focusing on energy efficiency, productivity and product quality – a perfect fit of the demand with ABB's offerings.

Rapid urbanization, an increase in the standard of living and the need for country-wide power distribution is another strong market requirement. To serve this rapidly growing market, ABB follows a five-point strategy:

- Strong organic growth of ABB in China
- Major investments in new product lines and factories as well as the formation of more joint ventures
- Taking full advantage of cost migration for ABB
- Continuous support of research and development centers as part of ABB's global network of corporate laboratories
- Develop highly talented and well-educated local talents

After 100 years of business in China, ABB can look back with pride on its contribution of a broad range of products and services to the Chinese market and looks forward to further cooperation to help meet the country's energy efficiency and environmental sustainability goals.

Franklin-Qi Wang





ABB (China) Ltd.
Beijing, China
franklin-qi.wang@cn.abb.com

Footnote

¹⁾ For more information on ABB's work in China, see **Eliasson B., & Lee Y. Y.** (Eds.). (2003). *Integrated Assessment of Sustainable Energy Systems in China: The China Energy Technology Program*. Dordrecht: Kluwer Academic Publishers.

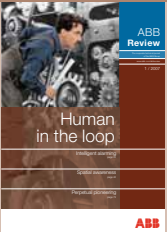
3 Bird nest – a Beijing stadium



			
1/2007: Human in the loop		3/2007: Pioneering collaboration	
Human in the loop	6	The optimal way to cooperate	6
The calm after the storm	11	Staying power on two legs	9
Galvanizing support	16	No step without the customer	11
Intelligent alarming	20	Collaborating for success	15
Peak performance	24	Thinking ahead	18
Design methods	30	Hydrofluoric acid alkylation	22
Case study	34	Tapping technology	27
Projections of productivity	37	A smooth shutdown	31
Spatial awareness	40	Combining forces to provide stability	34
Mapping the weakest link	44	Control and protection	39
The drive for simplicity	49	Detected!	42
Ambient intelligence	53	Safety in speed	46
Room for improvement	56	Partners in technology	50
Power semiconductors (part two)	62	Oiled and ready to go	53
Plainly speaking	67	Pressing challenge	58
Augmented reality	70	Welding dedication	63
Perpetual pioneering	73	Robotic specialists	65
The circuit breaker	75	Customer driven	68
		Integrated operations	72
		What loops can tell us	76
		Transforming history	80
			
2/2007: Energy efficiency		4/2007: World of innovation	
Trends and drivers	6	A successful 2007	6
Looking back from 2015	11	Signaling enhancements	12
Power to be efficient	14	Performing at a higher level	18
Ultra high voltage transmission	22	A touching movement	22
Congestion relief	28	A higher level of efficiency	26
Harnessing the wind	33	Integration breakthrough	32
Plant optimization	39	Speed and quality	38
OPTIMAX™	44	Wellness for your profit line	42
In a league of its own	45	On-site transformation	45
Energy efficient rolling	49	Integration guaranteed	49
The energy optimizers	53	Efficiency up, emissions down	53
More productivity, less pollution	58	Green ships on the high seas	58
Shades of green	62	The strongest link	62
Clean power from the sea	69	More muscle, less waste	66
Saving energy through drive efficiency	73	Wireless detection	70
Motor efficiency	81	100 years	74
Turbo chargers	85		

Editorial Board

Peter Terwiesch
Chief Technology Officer
Group R&D and Technology

Clarissa Haller
Corporate Communications

Ron Popper
Sustainability

Frank Duggan
Head of Group Account Management

Friedrich Pinnekamp
Chief Editor *ABB Review*,
Group R&D and Technology
friedrich.pinnekamp@ch.abb.com

Publisher

ABB Schweiz AG
Corporate Research
ABB Review/REV
CH-5405 Baden-Dättwil
Switzerland

ABB Review is published four times a year in English, French, German, Spanish, Chinese and Russian.

Partial reprints or reproductions are permitted subject to full acknowledgement. Complete reprints require the publisher's written consent.

ABB Review is free of charge to those with an interest in ABB's technology and objectives. For a free subscription please contact your nearest ABB representative or the publisher's office.

Publisher and copyright ©2007
ABB Ltd. Zurich/Switzerland

Printer

Vorarlberger Verlagsanstalt GmbH
AT-6850 Dornbirn/Austria

Layout

DAVILLA Werbeagentur GmbH
AT-6900 Bregenz/Austria

Disclaimer

The information contained herein reflects the views of the authors and is for informational purposes only. Readers should not act upon the information contained herein without seeking professional advice. We make publications available with the understanding that the authors are not rendering technical or other professional advice or opinions on specific facts or matters and assume no liability whatsoever in connection with their use. The companies of the ABB Group do not make any warranty or guarantee, or promise, expressed or implied, concerning the content or accuracy of the views expressed herein.

ISSN: 1013-3119

www.abb.com/abbreview

Preview 1/2008

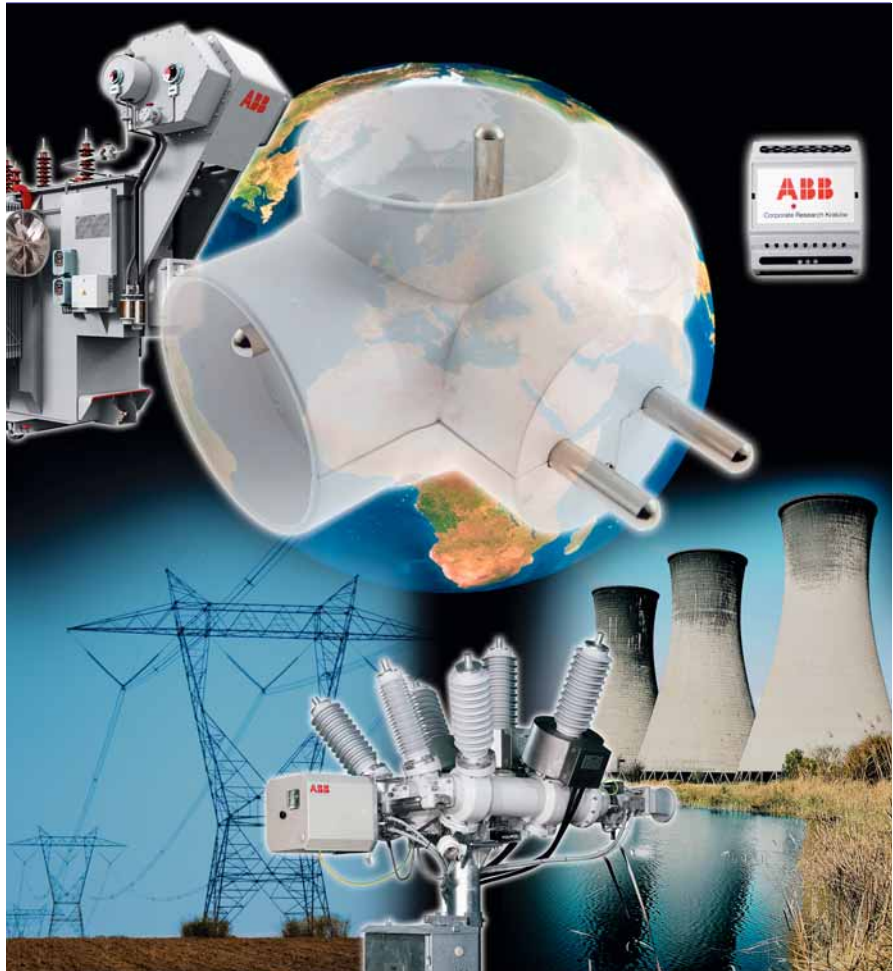

The technology behind the plug

Have you ever stopped to think about what goes on behind the electric plug? From mining the coal or running a wind turbine to running a train or switching the light on, ABB's technologies are involved every step of the way to support both the provision of electrical energy as well as its efficient use. The next issue of *ABB Review* will address how ABB is facilitating this provision; that is, the value chain "behind the plug."

We will share the state-of-the art and new achievements in electrical instal-

lations for all voltage levels. Advanced circuit breakers and transformers will be shown, and trends in modern transmission and distribution systems will be discussed. Efficient power generation with sophisticated process control within power plants is also on the slate for the next issue.

A visionary view for the value chain from primary energy exploitation to the delivery of electrical energy "at the plug" will be given, addressing smart distribution systems and advanced transmission technologies.

ABB is a leader in energy-saving technology:
minimum energy, maximum result!



ABB's energy-saving automation solutions support our goal to build a resource efficient society, whilst improving productivity.
For further information, please visit www.abb.com