

Type TD-4 Time Delay Relay

Effective: June 1989
Supersedes I.L. 41-759M Dated June 1985

* Denotes Change Since Previous Issue

CAUTION

Before putting relays into service operate the relay to check the electrical connections. Close the red handle switch last when placing the relay in service. Open the red handle switch first when removing the relay from service.

1. APPLICATION

The TD-4 static timing relay provides a dual time delay function. It is normally applied as a timer for zone 2 and zone 3 phase-distance functions in a stepped distance line relaying scheme. Two independent time delays may be set. The appropriate timing is selected, depending upon which inputs are present.

2. CONSTRUCTION

The type TD-4 relay consists of an auxiliary circuit for initiating the time delay, a reference voltage circuit, and a time delay circuit. A diode is added around the TX-Z2 and TX-Z3 coils on some types to override bounce of the initiating contact.

2.1 Auxiliary Circuit for Initiating Time Delay

The auxiliary circuit consists of two telephone-type relays (TX-Z2 and TX-Z3) and two tapped resistors (R_2 and R_3).

2.2 Reference Voltage Circuit

The reference voltage circuit consists of a silicon power regulator (DZ_1) and a tapped resistor (R_1).

2.3 Time Delay Circuit

The time delay circuit consists of a timing circuit module (M) a telephone type relay (TR) and two rheostats (T_2 and T_3). The timing circuit module consists of an R-C timing circuit, a zener diode for voltage sensing, and a transistorized amplifying circuit.

3. OPERATION

The type TD-4 relay is connected to the dc trip bus as shown in the external schematic, Fig. 4 and the timer control circuit, Fig. 5.

3.1 Timing Circuit Operation

The R-C timing circuit in Fig. 5 delivers an increasing voltage to the sensing zener diode (DZ_2). This zener diode breaks down at approximately 63% of the reference voltage which is supplied by DZ_1 . The rate of voltage rise is determined by the resistance (T_2 or T_3) in series with the timing capacitors. Therefore, the rheostat setting of T_2 or T_3 directly determines the time delay, as shown in Fig. 6.

When capacitor C changes to the voltage value e, DZ_2 breaks down to provide base drive for transistor TR_2 causing it to conduct. Emitter current of TR_2 provides base drive for transistor TR_1 . Transistor TR_1 conducts, energizing output relay TR to trip the breaker.

1. Zone 2 Operation, Non-Carrier

For a Zone 2 fault, both Zone 2 and Zone 3 KD-41 contacts close, energizing both TX-Z2 and TX-Z3. This completes the dc reference voltage circuit through DZ_1 . The time delay circuit is energized

All possible contingencies which may arise during installation, operation or maintenance, and all details and variations of this equipment do not purport to be covered by these instructions. If further information is desired by purchaser regarding this particular installation, operation or maintenance of this equipment, the local ABB representative should be contacted.

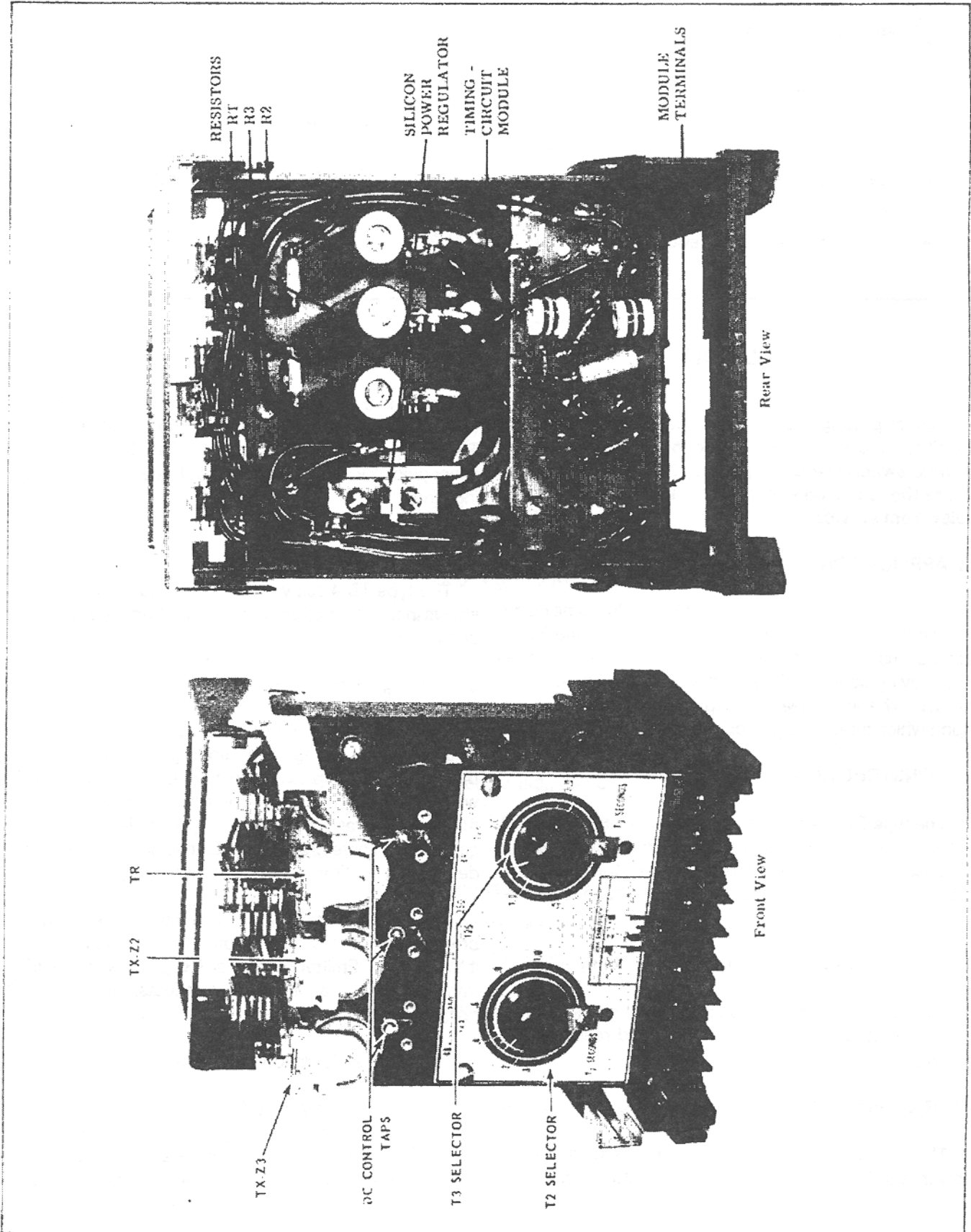

Fig. 1. Type TD-4 Relay Without Case

through rheostat T_2 . When the time delay is completed, telephone relay, TR, is energized and completes the trip circuit path through the normally open TX-Z2 contact.

2. Zone 2 Operation, Carrier

This case is similar to paragraph 1, except that the Zone 2 KD-4 contact only is closed. Therefore, only TX-Z2 is energized since Zone 3 reach is reversed. The operation of the timing circuit and trip circuit is identical to that described in paragraph 1.

3. Zone 3 Operation, Non-Carrier

For a Zone 3 fault the Zone 3 KD-41 contact only is closed. This energizes TX-Z3 and completes the timing circuit through rheostat T_3 . At the end of the time delay, TR is energized and completes the trip path through the normally closed TX-Z2 contact.

4. Operation on a Zone 2 Fault Which Appears as a Zone 3 Fault, Due to Infeed

A Zone 2 fault may appear to a distance relay as a Zone 3 fault. This condition occurs when current infeed changes the apparent impedance as seen by the distance relay.

When this fault occurs and the "forward" connection is used for the Zone 3 relay, it energizes TX-Z3 and starts the timing function at the Zone 3 rate, as described in paragraph 3. As soon as the infeed is removed, the Zone 2 distance relay operates to energize TX-Z2. The timing function now continues at the Zone 2 rate. The total time delay depends on the T_2 setting, the T_3 setting, and the time at which the breaker clears the infeed. In any event the trip time following Zone 2 KD-4 operation will be less than the T_3 setting.

4. CHARACTERISTICS

4.1 Time Delay Range

Zone 2: 0.1 sec.-1.0 sec.; 0.1 - 1.0 sec.

Zone 3: 0.5 sec.-3.0 sec.; 0.3 - 1.5 sec.

4.2 Reset Time

TR Dropout Time: 0.1 sec. or less

TX-Z2 and TX-Z3 - Dropout Time: 0.06 sec. or less

Discharge to timing capacitor: Discharges to less than 1% of full voltage in 0.015 sec.

For the relay with slow dropout the reset time is:

TX - Z2 dropout time = .045 - .075 sec.

TX - Z3 dropout time = .090 - 0.15 sec.

4.3 Voltage Rating Over the Temperature Range

48, 125 OR 250 volts dc. The relay can stand 110% voltage continuously, from -20°C. to 70°C.

4.4 Battery Drain

	48 Vdc	125 Vdc	250 Vdc
Non-operating Condition	0	0	0
Operating Condition			
Timing Circuit and DZ_1	50-90 MA	30-80 MA	25-70 MA
TX-Z ₂	117 MA	106 MA	103 MA
TX-Z ₃	117 MA	106 MA	103 MA

4.5 Accuracy

The accuracy of the time delay depends upon the repetition rate of consecutive timings, the supply voltage, and the ambient temperature. Self-heating has a negligible effect on the timing accuracy.

1. Nominal Setting

The first time delay, as measured with the test circuit shown in Fig. 7, taken at 25°C, and rated voltage (48, 125 or 250 Vdc), will be within 6 milliseconds of its setting for setting of .3 seconds and .7 seconds; this accuracy will be ±2%. For setting of .7 seconds or more, this accuracy will be ± 1-1/2%.

2. Consecutive Timings

If consecutive time checks are made at any given setting, the readings decrease. This change of time delay is due to the "voltage recovery" of the timing capacitor. Voltage recovery is a characteristic which all capacitors possess; it has been minimized by the selection of the timing capacitor in the TD-4.

The amount of change in time delay depends upon the pause, or duration of capacitor discharge be-

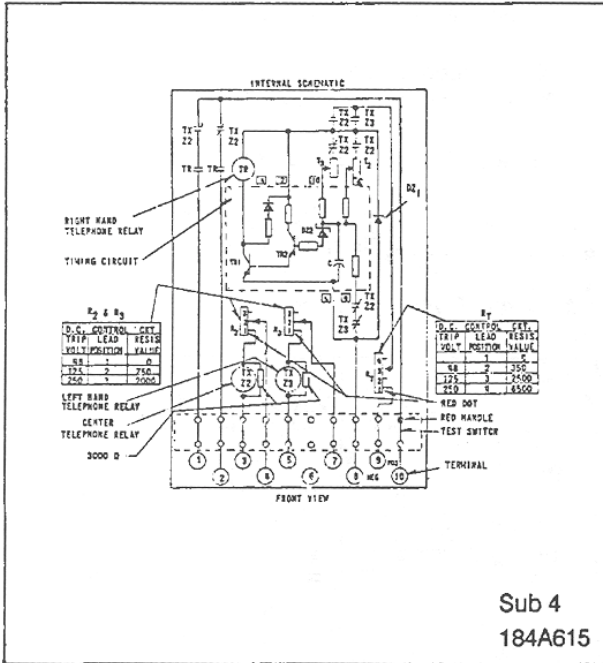

Sub 4
184A615

Fig. 2. Internal Schematic of the type TD-4 Relay in FT21 Case (Common Trip Circuits)

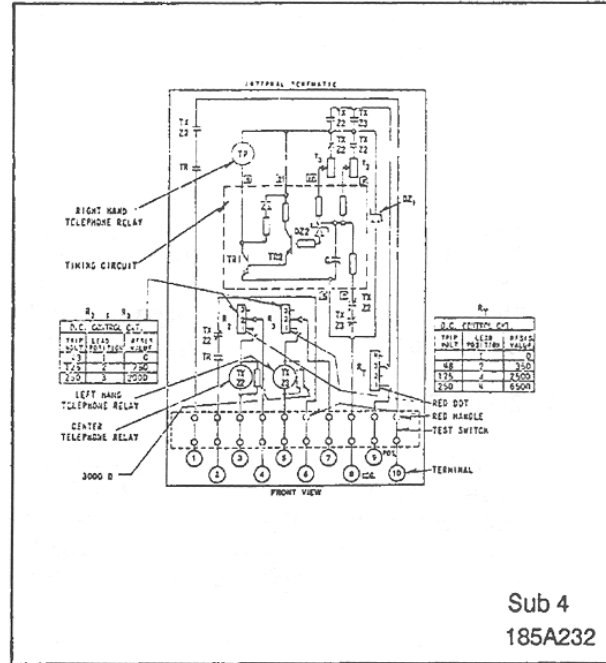

Sub 4
185A232

Fig. 3. Internal Schematic of the Type TD-4 Relay in FT21 Case (Independent Trip Circuits)

tween timings. If a pause of at least 3 seconds is observed between readings, the timing will repeat consistently, so that the total spread between the highest and lowest readings will be no more than 2% of the setting.

If timings are repeated rapidly, the decrease in time delay is considerable, between 3% and 4% in most cases. In no case will this decrease be more than 5% of the setting.

3. Supply Voltage

Changes in supply voltage, between 80% and 110% of nominal, cause time delay variations of no more than ±5 milliseconds for settings of .5 seconds or less, and no more than ±1% for settings above .5 seconds.

4. Ambient Temperature

Changes in ambient temperature cause changes in time delay. This variation in time delay is a direct function of capacitance change with temperature. Typical variation of time delay with temperature shown in Fig. 8.

NOMENCLATURE FOR TYPE TD-4 TIMING RELAY

TR Relay Unit	-Nominal Resistance 2,000 Ohms
TX-Z2 Relay Unit	-Nominal Resistance 500 Ohms
TX-Z3 Relay Unit	-Nominal Resistance 500 Ohms
R ₂ Tapped Resistor	-See Internal Schematic
R ₃ Tapped Resistor	-See Internal Schematic
R _T Tapped Resistor	-See Internal Schematic
DZ ₁ Zener Diode	-30 Volt Breakdown, 10 Watt
T ₂ Rheostat	-Adjustable 0-40,000 Ohms
T ₃ Rheostat	-Adjustable 0-100,000 Ohms 0-50,000 Ohms (.3-1.5 Sec. Range)
M Module	-Timing Circuit

* 5. SETTINGS

The T₂ and T₃ timers are set to coordinate with adjacent line relaying. The T₂ setting must allow for adjacent line zone 1 relay operation and breaker clearing - 15 cycles is a commonly used setting.

T₃ must coordinate with adjacent line zone 2 time tripping. 30 cycles is a commonly used setting.

R₂, R₃ or R_T must be chosen depending upon the dc voltage in use.

Time settings are made by adjusting rheostates T₂ and T₃. See figure 1.

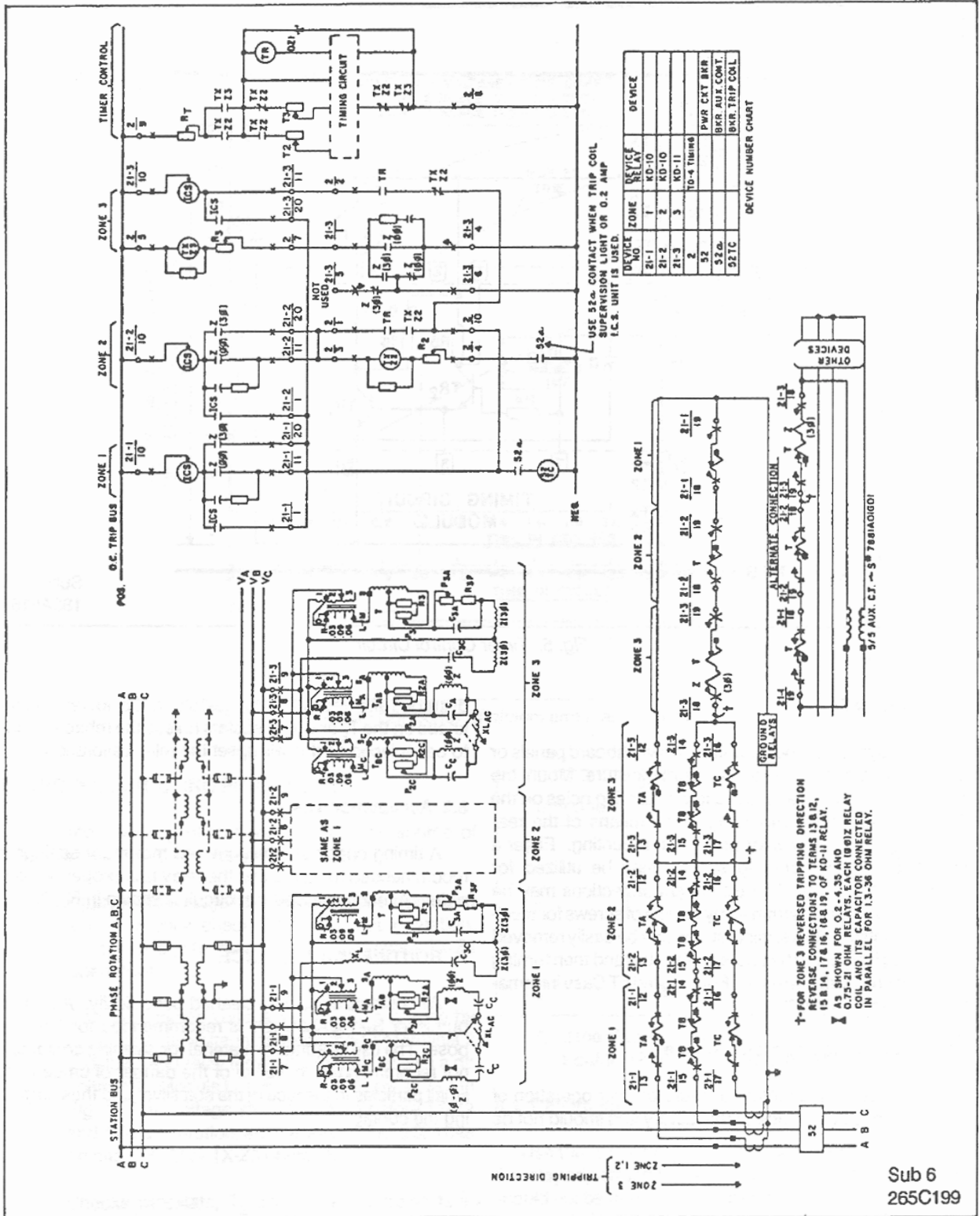

* Fig. 4. External Schematic of the Type TD-4 Relay

Sub 6
265C199

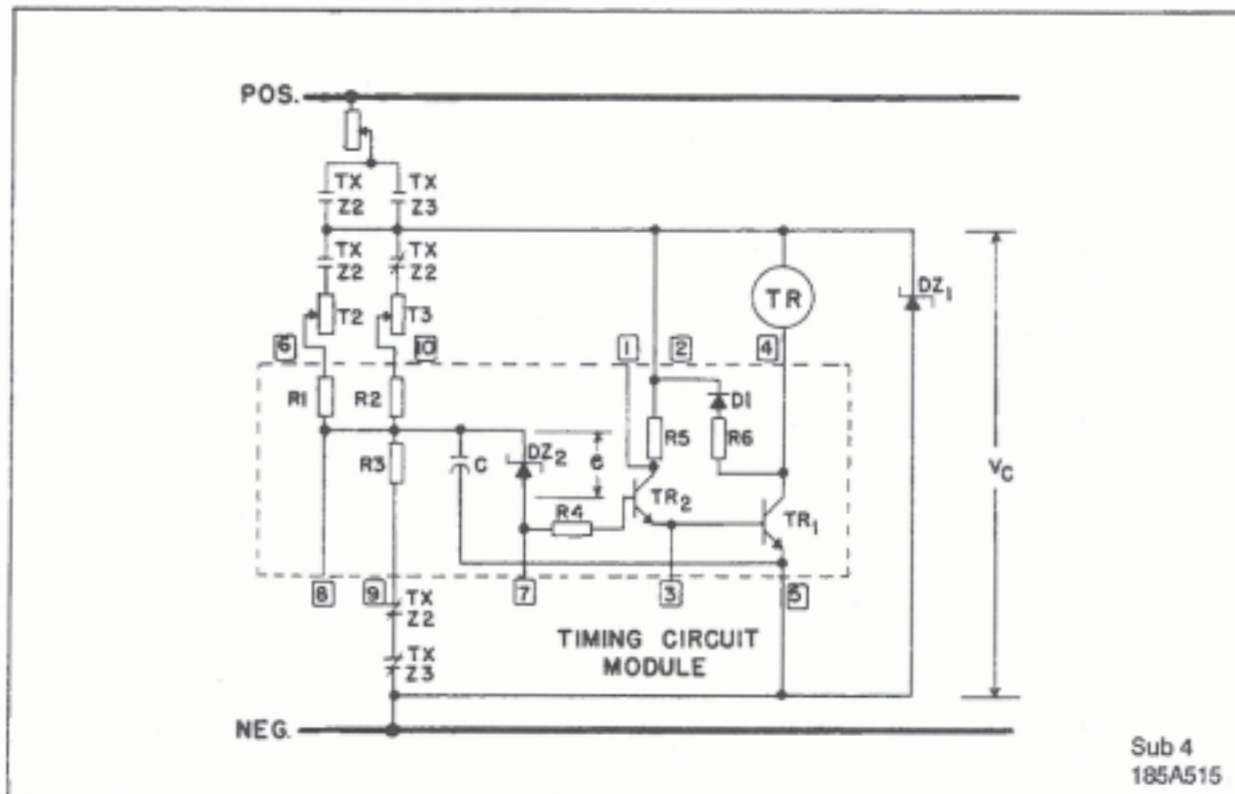

Fig. 5. Timer Control Circuit

6. INSTALLATION

The relays should be mounted on switchboard panels or their equivalent in a location free from moisture. Mount the relay vertically by means of the four mounting holes on the flange for semi-flush mounting or by means of the rear mounting stud or studs for projection mounting. Either a mounting or the mounting screws may be utilized for grounding the relay. The electrical connections may be made directly to the terminals by means of screws for steel-panel mounting. The terminal studs may be easily removed or inserted by locking two nuts on the stud and then turning the proper nut with a wrench. For detailed FT Case information, refer to I.L. 41-076.

6.1 Adjustments and Maintenance

The proper adjustments to insure correct operation of this relay have been made at the factory and should not be

disturbed after receipt by the customer. Do not remove the knobs on the T_2 and T_3 rheostats unless the rheostats are to be replaced as this will upset the relay calibration.

6.2 Acceptance Tests

A timing check at minimum and maximum settings is recommended to insure that the relay is in proper working order. A recommended test circuit is shown in Fig. 7.

7. ROUTINE MAINTENANCE

All contacts should be cleaned periodically. A contact burnisher S#182A836HO1 is recommended for this purpose. The use of abrasive material for cleaning contacts is not recommended, because of the danger of embedding small particles in the face of the soft silver and thus, impairing the contact.

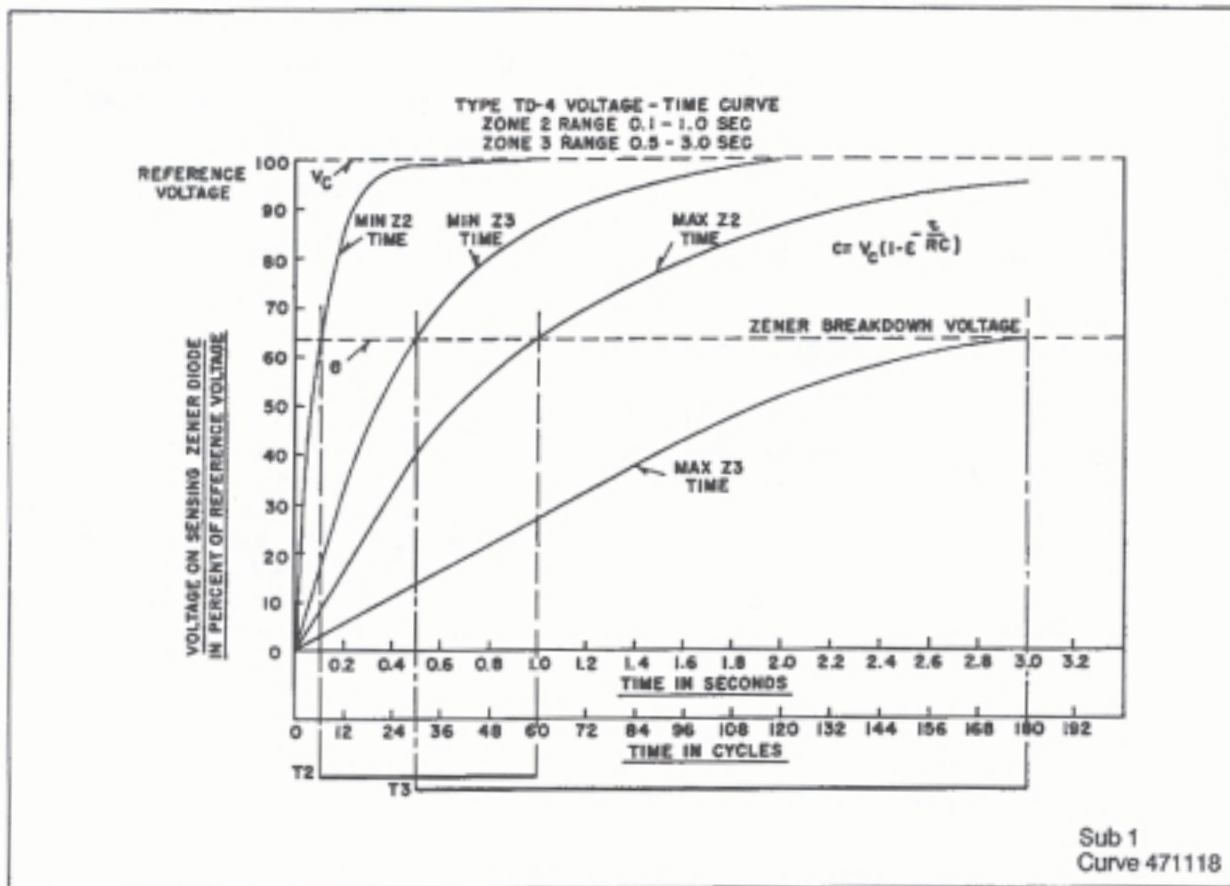

Fig. 6. Voltage-Time Curves for Minimum and Maximum Time Settings

8. TROUBLESHOOTING PROCEDURE

Use the following procedure to locate the source of trouble if the TD-4 is not operating correctly.

1. Apply rated voltage between relay terminals 3 and 4 and visually check TX-Z2 contact operation. (Apply voltage terminals 5 and 7 and check TX-Z3 operation).
2. Check reference voltage circuit. This is done by measuring the voltage between module terminal 2 (positive) and relay terminal 8 (negative) with a dc voltmeter. Module terminal numbers are shown in Fig. 1. This voltage should be zero before TX-Z2 and TX-Z3 operation, and between 27 and 32 volts dc after TX-Z2 or TX-Z3 operation.
3. Checks rheostats, T_2 and T_3 , and tripping telephone relay, T_R , with an ohmmeter. The readings should be as follows:

Component	Ohmmeter Between Module Terminals	Resistance
T_2	2 and 6	0-40,000 ohms (TX-Z2 operated)
T_3	2 and 10	0-100,000 ohms (.5-3.0 Sec.)
T_R	2 and 4	0-50,000 ohms (.3-1.5 Sec.) 2,000 ohms

4. If the above checks do not determine the source of trouble, either the wiring or the module, M is faulty.

8.1 Calibration

Use the following procedure for calibrating the relay if the relay adjustments have been disturbed. This procedure should not be used until it is apparent that the relay is not in proper working order. Before calibrating, follow the Trouble-shooting Procedure to locate the source of trouble.

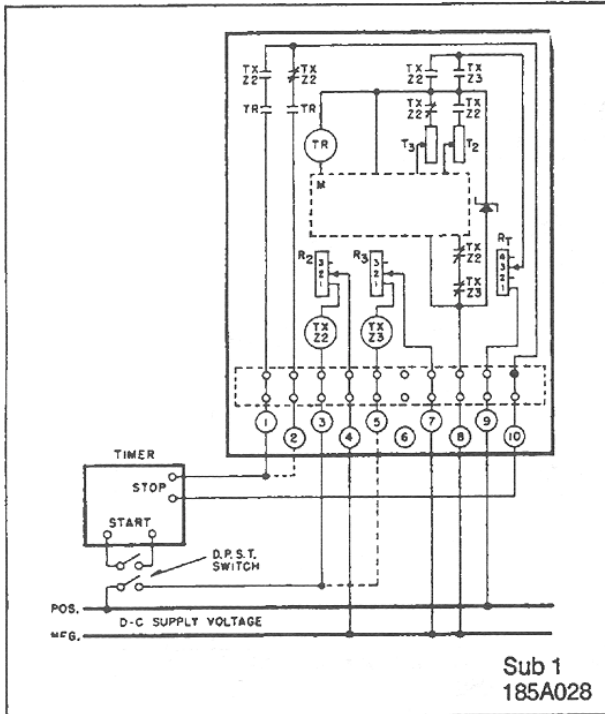

Fig. 7. Test Circuit for the Type TD-4 Relay. (Jumper Terminals 6 and 10 When Testing Relay with Independent Trip Contacts)

1. Telephone Type Relay Adjustment

Adjust the armature gap on the three telephone type relays to be approximately .004" with the armature closed. This is done with the armature set-screw and lock-nut. Also, adjust contact leaf springs to obtain at least .015" gap on all contacts and at least .010" follow on all normally open contacts and at least .005" follow on all normally closed contacts.

2. Rheostat Knob Adjustment, Same Scale Plate

If it is necessary to replace the T_2 or T_3 rheostats, the relay may be recalibrated with the same scale plate. This is done by rotating the shaft, without knob, until a 1.0 second delay is measured for T_2 , or a .5 second delay is measured for T_3 . Then, align the knob for this delay and tighten the knob set-screw securely. There should be a pause of several seconds between readings for all time delays above .5 seconds. See section under Accuracy for discussion of this.

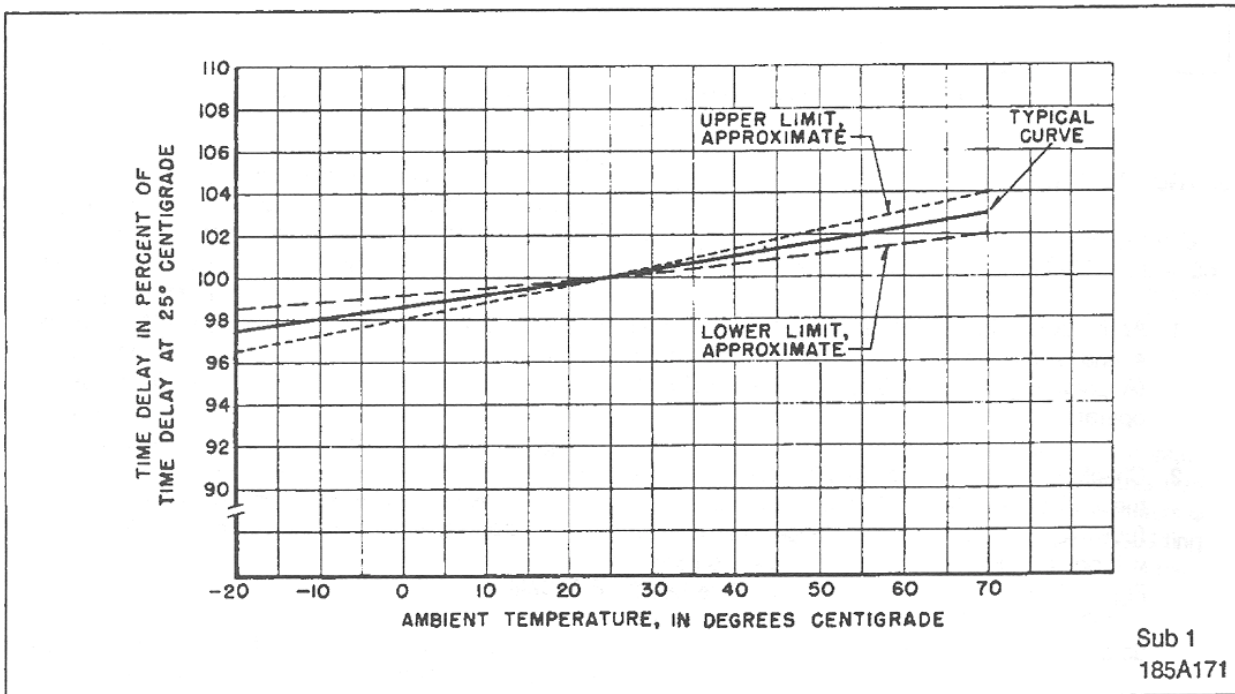

Fig. 8. Timing Variations with Temperature Changes.

3. Scale Plate Calibration, New Scale Plate

If it is necessary to replace the silicon power regulator (DZ₁), or the module (M), the relay should be recalibrated with a new scale plate.

The first step should be to insure that the knob is approximately vertically for the mid-scale time delay (.550 sec. for T₂ and 1.75 sec. for T₃). This will locate the calibration lines symmetrically around

the scale plate. After centering and securely locking the knob on the rheostat shaft, new calibration lines may be marked on the scale plate. When scribing calibration lines for delays above .5 sec., there should be a pause of at least 3 seconds between readings.

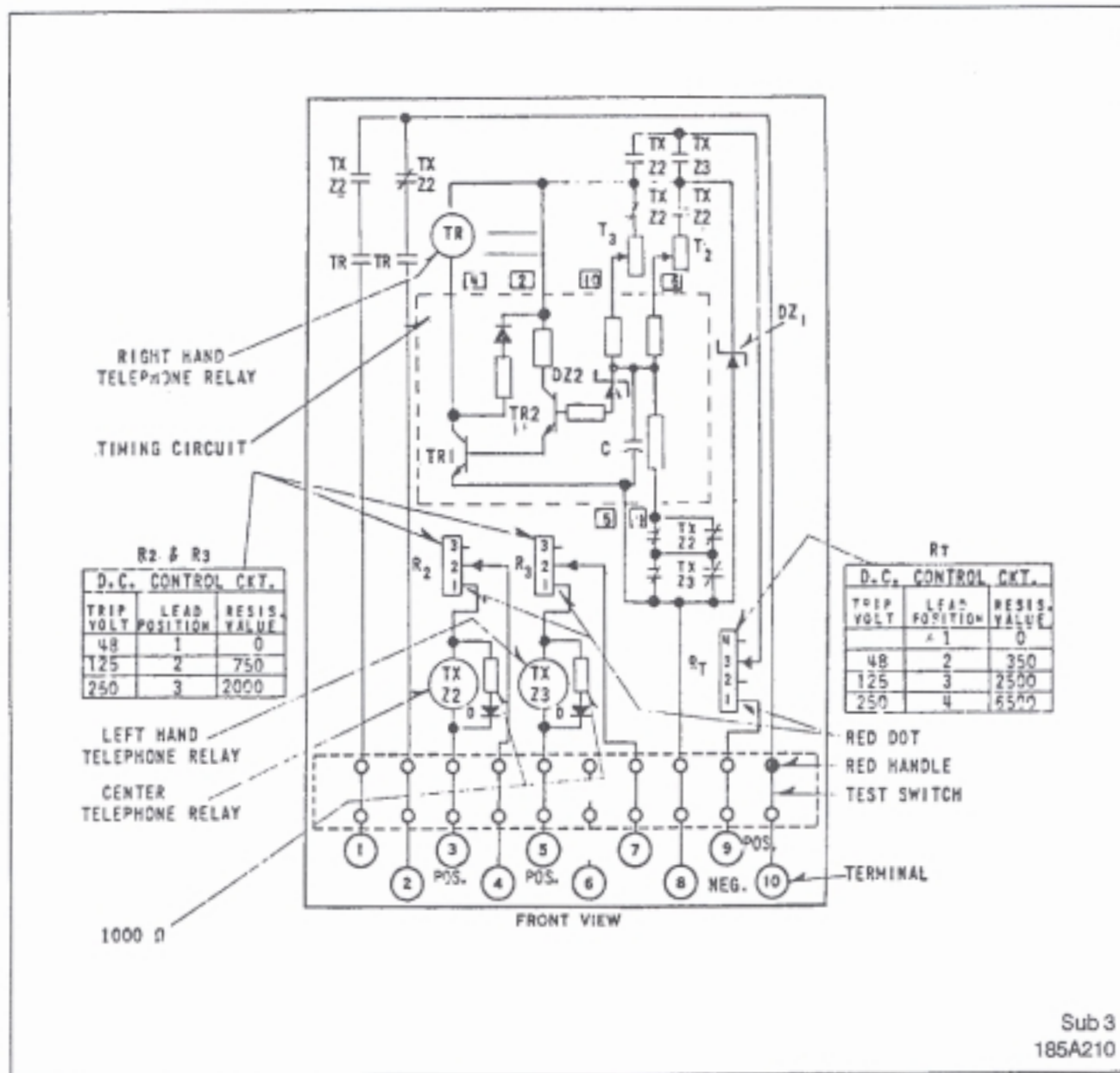

Fig. 9. Internal Schematic of the Type TD-4 Relay with Slow Dropout Relay (Common Trip Circuit)

Sub 3
185A210

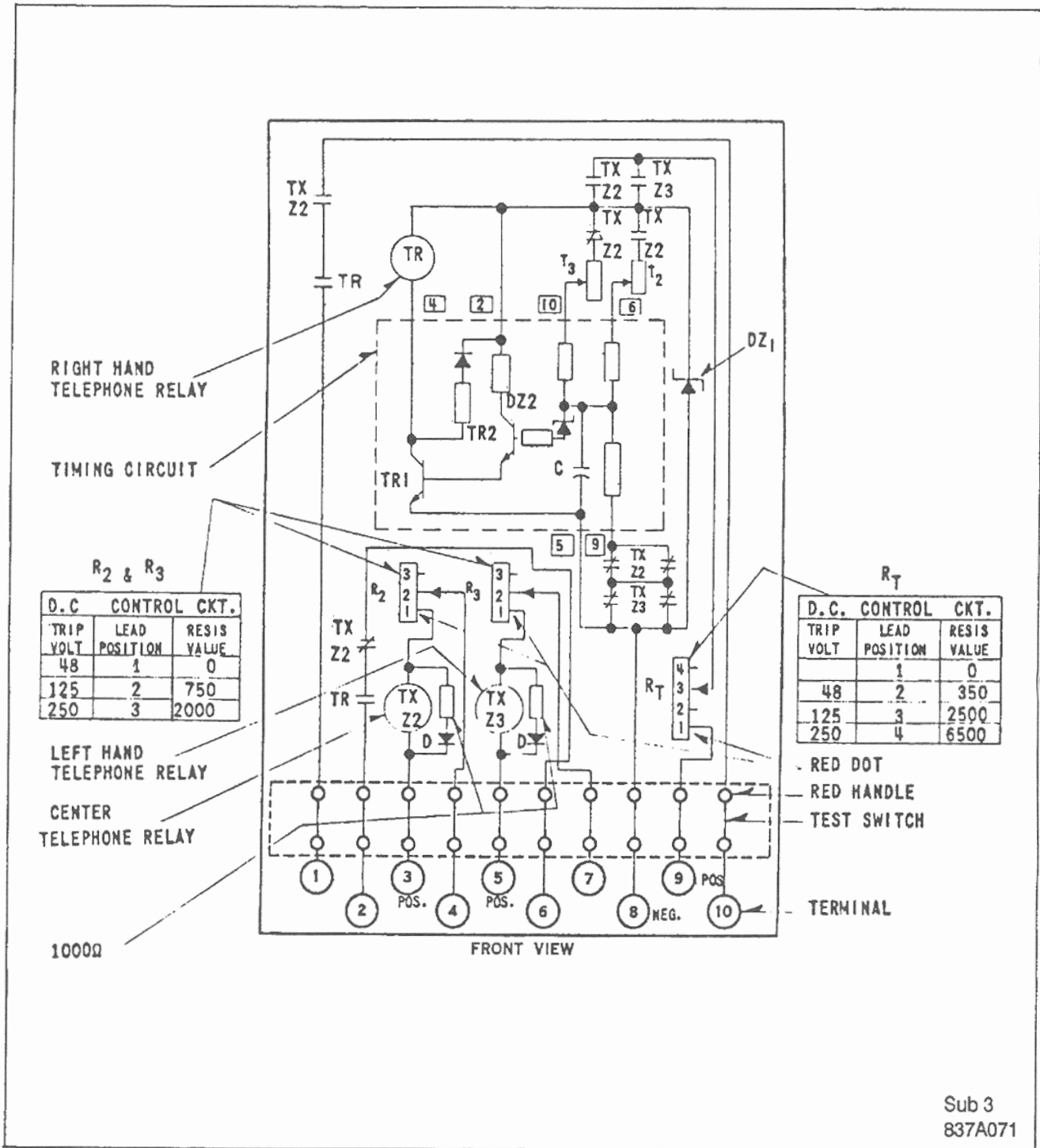
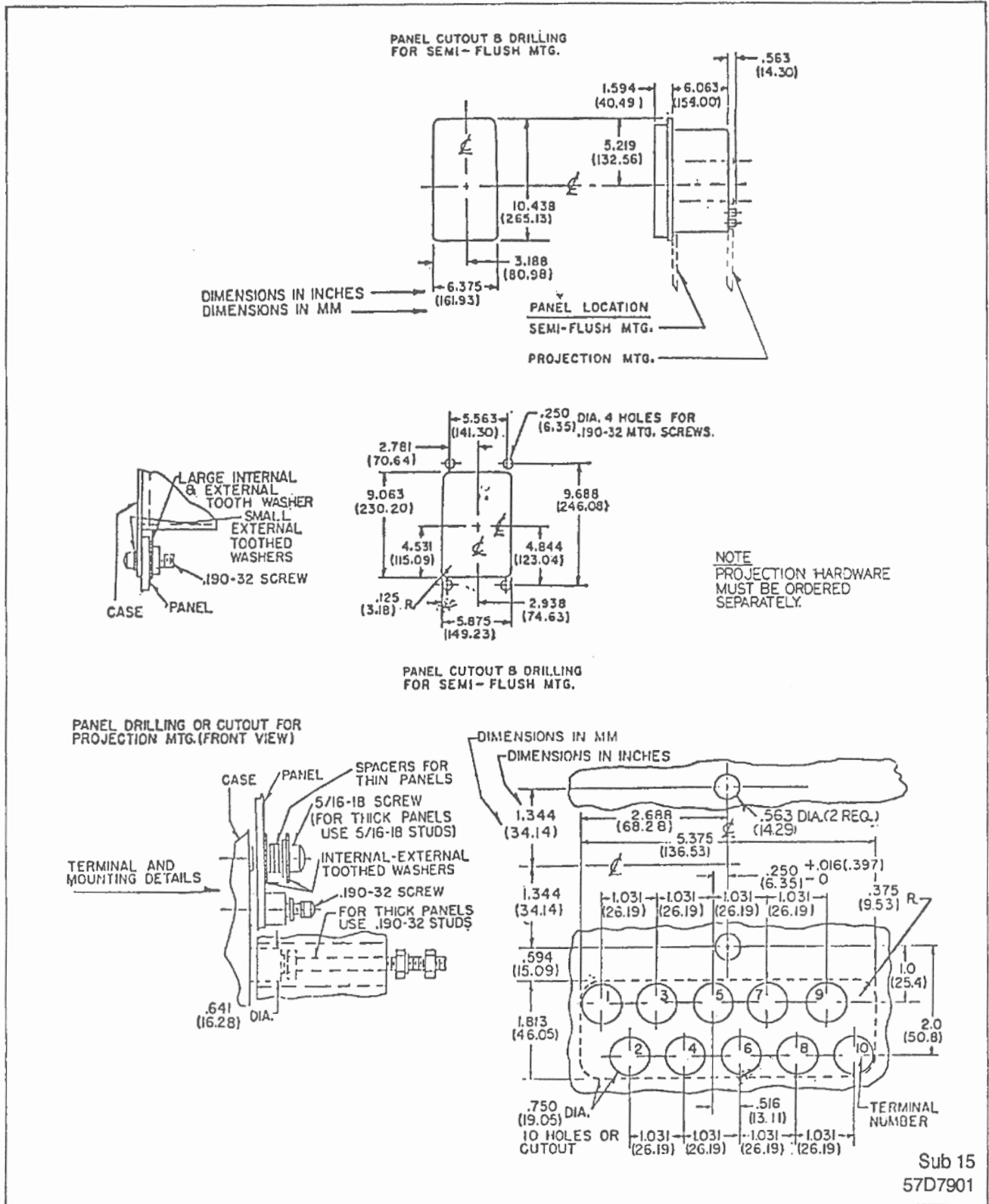

Fig. 10. Internal Schematic of the Type TD-4 Relay with Slow Dropout Relay (Independent Trip Circuits)



* Fig. 11. Outline and Drilling Plan for the Type TD-4 Relay in the FT21 Case

TABLE OF REPLACEABLE PARTS

CIRCUIT SYMBOL (See Int.Schem. and also Fig.5)	TIME RANGE	DESCRIPTION	STYLE NO.
TX22	All	Telephone relay, 500 ohm coil	Refer-Relay Style
TX23	All	Telephone relay, 500 ohm coil	Refer-Relay Style
TR	All	Telephone Relay, 2000 ohm coil	407C280H09
R ₁	All	Resistor, 25 watts, 6500 ohms, with tap at 350 and 2500 ohms	184A651H01
R ₂	All	Resistor, 25 watts, 2000 ohms, with tap at 750 ohms	11D9511H04
R ₃	All	Resistor, 25 watts, 2000 ohms, with tap at 750 ohms	11D9511H04
R ₁	All	Resistor, 1050 ohms	184A868G01
R ₃	All	Resistor, 120 ohms, 1/2 watt	184A764H05
R ₄	All	Resistor, 10K ohms 1%, 1/2 watt	184A764H51
R ₅	All	Resistor, 10K ohms, 1%, 1/2 watt	184A764H51
R ₆	All	Resistor, 3,920 ohms, 1/2 watt	184A764H41
D ₁	All	Diode 1N538	407C703H03
TR ₁ , TR ₂	All	Transistor 2N697	184A638H18
DZ ₁	All	Zener Diode 10W, 1N2989B, 30V ± 5%	629A798H01
DZ ₂	All	Zener Diode, 1/2 watt, 18-20 volts	185A033H01
C	All	Capacitor, 27 ufd., 35 Vdc	187A508H15
T ₂	All	Potentiometer, 40K ohms	184A756H01
T ₃	.3-1.5 Sec.	Potentiometer, 50K ohms	184A756H03
T ₃	.5-3.0 Sec.	Potentiometer, 100K ohms	184A756H02
R ₂	.3-1.5 Sec.	Resistor 5000 ohms	184A868G03
R ₂	.5-3.0 Sec.	Resistor, 8000 ohms	184A868OG02
Resistor Across TX Coil	All	Resistor, 3000 ohms, 3 watt	184A636H05
Resistor Across TX Coil (Slow Dropout)	All	Resistor, 1000 ohms, 1/2 watt	184A764H27
Diode Across TX Coil (Slow Dropout)	All	Diode 1N1224	508C320H12



ABB Inc.

4300 Coral Ridge Drive
Coral Springs, Florida 33065

Telephone: +1 954-752-6700

Fax: +1 954-345-5329

www.abb.com/substation automation