

APPLICATION GUIDE

Harmonics in water applications



Table of contents

4–7	Harmonics in general and why we should care
4	Introduction
4	Basics of harmonics
5	Causes of harmonic distortion
5	Problems caused by harmonic distortion
6	Economic issues caused by harmonic distortion
6	Harmonics in critical facilities
7	Power factor
8–12	Different ways to mitigate harmonics
8	Six-pulse drive, no reactor
8	Six-pulse drive with 3–5% reactor
9	Passive filters
10	Active filters
11	Multi-pulse solutions
12	Active front end
12	Other mitigation technologies
14	Summary

Harmonics in general and why we should care

Introduction

The water industry requires a reliable solution for securing the flow of water and wastewater. Pumping and aeration systems are integral parts of a reliable solution and these systems consume a considerable amount of energy. This energy consumption can be substantially reduced when variable frequency drives (VFDs) are properly introduced into these systems.

VFDs, along with many other types of electronics, cause a phenomenon known as power line harmonics. The advantages of using a VFD far outweigh the negative effects of harmonics, but it is important to be aware of harmonics, the potential problems they can cause, and the solutions that are available to mitigate those harmonics.

While this paper focuses on VFDs as a source of harmonics, it is important to note that VFDs are not the only source of harmonics in a system. However, VFDs are often the focus of harmonic calculation and mitigation conversations due to the fact that VFDs in water applications may make up a significant portion of the overall power consumption. Examples of VFDs in water and wastewater applications include pumps, blowers, compressors, digesters and conveyors.

Harmonics appear on the voltage waveform due to electronic devices that draw current in a non-linear way. Harmonics are typically measured as a percentage value, called total harmonic distortion (THD). It is the ratio of the RMS (root mean square) harmonic content over the RMS value of the fundamental frequency. THD represents the percentage of deviation from the fundamental sinusoidal waveform. If the voltage or current does not contain any harmonics, the THD would be zero percent. As the amount of harmonics increases, the THD percentage increases as well.

There are a variety of industry standards used to identify an acceptable amount of harmonic distortion compared to a troublesome amount of distortion. For example, IEEE 519-2014 is used in the United States and some countries in Asia. There are also electromagnetic compatibility (EMC) standards for harmonics in Europe and

Asia. These standards are written from the utilities' point of view, thus they are intended to prevent customers from generating a level of harmonic distortion high enough to impact the power quality of neighboring customers on the electrical grid.

The word "harmonics" is a broad term and is used in many different industries. Unfortunately, certain electrical problems are incorrectly blamed on harmonics. These harmonics should not be confused with radio frequency interference (RFI), which occurs at much higher frequencies than harmonics. Power line harmonics are low-frequency, thus they do not interfere with wireless LAN signals, cellphones, FM or AM radios, or any equipment that is specifically sensitive to high-frequency noise.

Basics of harmonics

Voltage harmonics are the distortion of the voltage waveform. Likewise, current harmonics are the distortion of the current waveform. These distorted waveforms are difficult to quantify with a simple equation, thus a mathematical method is used (called a Fourier analysis) when discussing harmonics. This method determines the magnitude and frequency of many smaller sinusoidal waveforms that make up the distorted waveform seen at a facility. This allows the engineer to identify which are the most problematic individual harmonics and to provide corrective measures to reduce those harmonics.

As stated in the introduction, harmonics are often discussed in terms of a THD percentage. This percentage value describes how badly the waveform is distorted from a pure sinusoidal waveform. A waveform that is highly distorted will have a higher THD percentage value. The following two formulas are used to quantify the amount of harmonics in a system.

$$THD_V = \frac{\sqrt{V_2^2 + V_3^2 + V_4^2 \dots V_n^2}}{V_1} * 100\%$$

$$THD_I = \frac{\sqrt{I_2^2 + I_3^2 + I_4^2 \dots I_n^2}}{I_1} * 100\%$$

THD_V is the total harmonic distortion of the voltage waveform. THD_I is the total harmonic

distortion of the current waveform. In both cases, the calculation is based on the ratio of the RMS harmonic content over the RMS value of the fundamental value. In other words, the more harmonic content, the higher the THD percentage.

While outside the scope of this paper, another important topic involving harmonics is to understand what THD_v and THD_i levels are acceptable for a water utility. Each system is unique and takes into account the size of a utility's load compared to the capacity of the electrical utility, known as the short circuit ratio. Also, understanding where to measure the harmonics, known as the point of common coupling (PCC), is often a misunderstood concept. In short, the PCC is typically the point where the water utility's network is connected to the electrical utility grid. Total demand distortion (TDD) is measured at the PCC in lieu of THD_i . The TDD is typically used to evaluate harmonics for the entire utility, while THD_i is used to evaluate harmonics for an individual device within the utility.

Causes of harmonic distortion

Harmonics are caused by non-linear loads. Non-linear loads do not draw current sinusoidally from the utility. Examples of non-linear loads include VFDs, EC motors, LED lighting, photocopiers, computers, uninterruptible power supplies, televisions, and the majority of electronics that include a power supply. The most significant causes of harmonics in the utilities are typically non-linear, three-phase power, and the more power there is, the bigger the harmonic currents in the network will be.

The next section reviews the electrical characteristics of a VFD. This is to illustrate an example of a non-linear load. The most popular VFD design works by taking a three-phase AC line input voltage and rectifying the voltage through diodes. This turns the voltage into a smooth DC voltage across a bank of capacitors. The VFD then converts the DC back into an AC waveform for the motor in order to control the speed, torque and direction of the motor. The non-linear current is created by the three-phase AC-to-DC rectification.

Problems caused by harmonic distortion

High levels of harmonic distortion in an utility can create a wide range of problems. Some of the problems that may be encountered are:

- Premature failure and reduced lifespan of devices often occurs when overheating is present, such as:
 - Overheating of transformers, cables, circuit breakers and fuses
 - Overheating of motors that are powered directly across the line
- Nuisance trips of breakers and fuses due to the added heat and harmonic loading
- Unstable operation of backup generators
- Unstable operation of sensitive electronics that require a pure sinusoidal AC waveform
- Flickering lights

These issues are often hard to identify as harmonics-related problems. For example, we know that motors are designed to run almost to the point of overheating. Under normal operating conditions, placing one's hand on a fully loaded motor may be too uncomfortable after a second

—
01 Pure sinusoidal current waveform with no harmonics

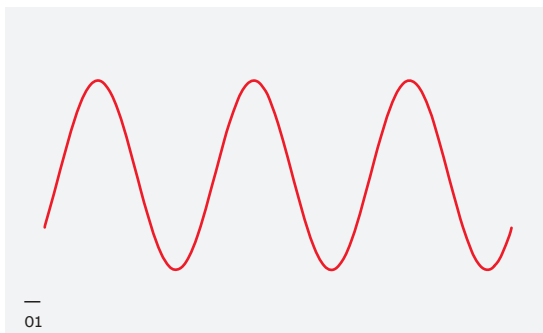

—
02 Current waveform with harmonics

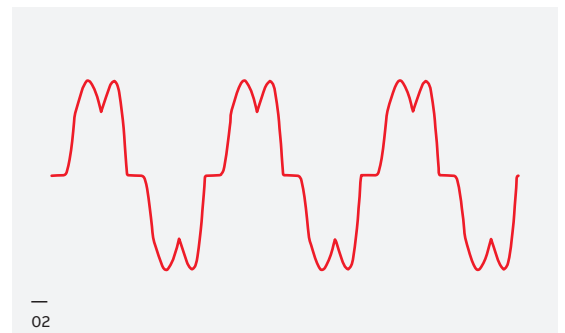

—
03 Potential impacts
of harmonics on
transformers

or two. Thus, how would the typical maintenance manager realize if that motor were running an extra ten degrees hotter due to harmonics? And at the same time the lifetime of that same motor is decreasing to six years instead of 12 years? This example is just one of many hidden economic aspects tied to harmonics, which will be covered in the next section. It is important to note that this example was based on a motor that was powered across the line, thus exposed to a distorted waveform. VFDs essentially buffer a motor from power line harmonics, so motors powered from a VFD would not experience this power line harmonic phenomenon leading to premature failure.

Economic issues caused by harmonic distortion

Harmonics have an economic impact during all phases of a utility's lifespan. First, there is the upfront cost of either sizing equipment to handle harmonics, or investing in harmonic mitigation in the first place. Secondly, there are the day-to-day added costs due to the inefficiency of the system. Finally, there are the costs due to premature failure of equipment.

One way to deal with harmonics is to simply oversize portions of the electrical infrastructure within the utility. Transformers and wire size may be upsized to handle the added harmonic content and heat. Backup generators also need to be oversized in systems with significant harmonic loading. There are multiple aspects to generator sizing. The generator has to be capable of handling the added harmonic current. Also, the generator's voltage regulator has to be capable of handling the voltage distortion without causing unstable operation.

An alternative to paying for oversized equipment would be to invest in products that create less harmonics. Using a VFD as an example, lower-cost VFDs can draw 67 percent (or more) current than a moderate-cost VFD that includes a DC choke or input line reactor. The best solution is achieved with mitigation technologies that are able to mitigate the harmonics to below 3 percent.

The day-to-day costs of harmonic-induced system inefficiencies are often hidden and overlooked. A transformer or motor that runs hotter means

it is using energy in an inefficient manner, since energy is being used to create heat, instead of powering other loads in the utility. The costs of failed equipment are not hidden. However, identifying those failures and costs as being related to harmonics is a challenge.

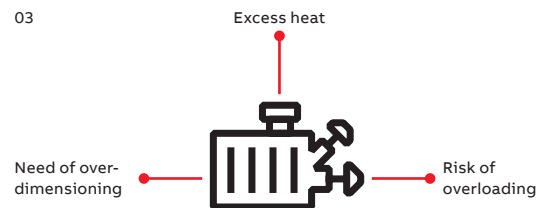

Addressing harmonics during the design phase allows for other parts of the electrical infrastructure to cost less (i.e. not oversized). Once harmonics are addressed, further long-term cost savings are achieved through higher efficiencies and longer-lasting equipment.

Harmonics in critical applications

The previous sections of this document describe issues that may impact any utility. However, there are certain applications in water industry that have to pay very close attention to power quality – and so pay close attention to harmonics – as uninterrupted flow of water and wastewater is vital. Water and wastewater utilities, pumping stations with backup generators and pumping stations in remote locations are usually sensitive to harmonics.

Water utilities need to make sure there are no disturbances to sensitive electrical components, such as ozone generators and UV lights, that might make the outcome of the treatment process impure. Reliable operation of the backup generator is essential in wastewater pumping stations to avoid overflowing of the wastewater tank or in booster stations to keep the water network pressurized. Maintaining pumping even in weak and fluctuating networks is essential in the rural area.

System designers should be aware of the impact of harmonics on any critical application. The next part of the paper talks about the power factor, which is an electrical component that is also affected by harmonics.



Power factor

Power factor is an electrical term used in the electrical industry. However, it is a term that can cause confusion because there are actually three different types of power factor: true power factor, displacement power factor, and distortion power factor.

$$pf_{true} = \frac{P_{avg1}}{V_{1rms}I_{1rms}} * \frac{1}{\sqrt{1 + \left(\frac{THD_I}{100}\right)^2}} = pf_{disp} * pf_{dist}$$

The equation shows the relationship between these different power factor types. True power factor takes into account the displacement power factor (also known as $\cos\phi$) and distortion power factor (that is a function of the amount of harmonic current).

The three most important takeaways on power factor for an engineer or utility manager are:

- Some electrical utilities charge fees to customers who have a poor power factor, and/or offer a cost reduction on the electric bills of customers who have a good power factor. Traditionally the reactive power compensation is made by investing to separate capacitor banks.
- Adding a VFD to control a motor will improve the displacement power factor (pf_{disp}) which helps to eliminate the need of capacitor banks.
- VFDs that generate less harmonics will improve both elements of true power factor (pf_{true}) to unity, displacements (pf_{disp}) and distortion (pf_{dist}) power factors. This removes the need of capacitor banks totally and maximizes system efficiency.

Different ways to mitigate harmonics

There are many ways to mitigate harmonics and there is no “one size fits all” solution.

The table below compares the THD_i of various harmonic mitigation technologies, along with other comparisons.

	Six-pulse VFD no reactor/ choke	Six-pulse VFD Low DC bus capacitance	Six-pulse VFD + 5% reactor/choke	3-phase VFD Active front end drive *)
Typical THD_i	90-120%	35-40%	35-45 %	3-5 %
VFD system price **)	\$	\$	\$\$	\$\$\$
Footprint	◊	◊	◊◊	◊◊◊
Pros	Simple and low cost solution, acceptable for installations with low quantities of small drives.	Simple and low cost solution that results in some mitigation of current harmonics (THD_i).	Standard solution in water and wastewater applications.	Best harmonic performance of any of the solutions. Easy installation, only 3 wires in and 3 wires out. Ability to boost output voltage during low-line conditions. Unity true power factor.
Cons	High harmonic content, not recommended for installations with higher quantities of drives. Susceptible to poor power quality.	Higher voltage distortion (THD_v), more than the six-pulse VFD with 5% reactor/choke. More susceptible to problems caused by poor power quality. Almost no under voltage ride-through ability.	Systems with a large quantity or large sizes of drives, may require additional harmonic mitigation.	The drive itself generates slightly more heat than a standard six-pulse drive with reactor.

*) Valuations are based on ABB low harmonic drives

**) System price considers VFD & installation costs

—
04 Six-pulse drive
without mitigation

Six-pulse drive, no reactor

This would describe a standard six-pulse drive without any harmonic mitigation. This type of drive is used because of its lower cost and small footprint. This VFD design can be used as a reference point, since no mitigation technique is used. The exact current distortion varies based on the design, but values between 90 and 120 percent are typical.

It is important to note that there is a variation of this drive on the market that utilizes an undersized DC bus capacitor. This design makes the THD_i value look better, but it has a significant negative impact on THD_v in the power system. This type of drive is very susceptible to overvoltage and undervoltage tripping due to line transients, sags and surges.

Six-pulse drive with 3–5% reactor

A standard six-pulse drive with added DC choke or input line AC reactor increases the impedance,

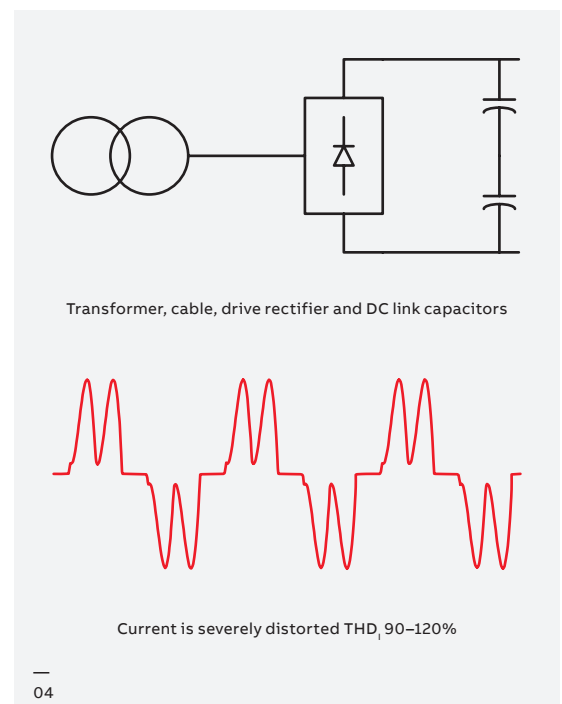

	Six-pulse VFD + passive filter	Matrix technology drives	Multipulse VFD	Six-pulse VFD + active filter
Typical THD_i	5-10%	5-13 %	12 pulse 10-15% 18 Pulse 5-8% due to actual system dynamics, phase unbalance and background distortion.	4-7%
VFD system price **)	\$\$\$	\$\$\$\$	\$\$\$\$	\$\$\$\$\$
Footprint	☆☆☆☆	☆☆	☆☆☆☆☆	☆☆☆☆
Pros	Assuming physical space is available, a passive harmonic filter can be added after the drive is installed, if harmonics are determined to be a problem.	Includes regenerative braking.	Traditional harmonic mitigation method.	One active filter can clean up the harmonics from multiple drives/loads.
Cons	Leading power factor at light loads unless the filter's capacitors are switched out of the circuit. Risk of resonances between the filter capacitors and other capacitors in the system. Complex wiring.	Low harmonic mode (5% THD _i) does not allow full speed control throughout the entire frequency range, as it can only modulate up to 93% voltage. No under voltage ride-through of power circuitry due to the lack of DC bus.	Very large footprint. Significant number of points of failure. Optimal harmonic performance requires perfectly balanced AC power feed with little background distortion. Complex wiring and special transformer required. Very difficult to retrofit in the field.	Typically the most expensive solution. The filter becomes a single point of failure for harmonic mitigation. A filter failure could result in significant/immediate harmonic related issues within the system. Complex wiring.

05 Six-pulse drive with 3-5% reactor

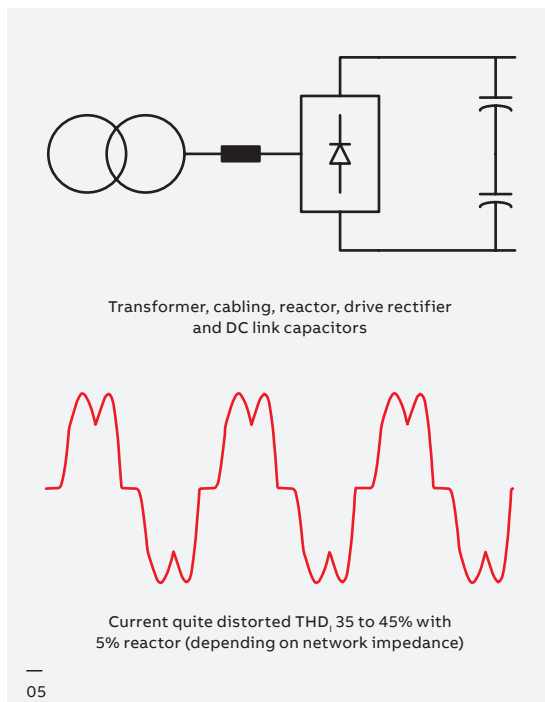

05

and through that, the drive decreases the harmonic current levels to 35-45 percent. ABB recommends this solution as a starting point for all drives used in the water and wastewater systems. Then, if a harmonic calculation determines further reduction in the THD_i is required, upgrade to a better harmonic mitigation technology.

Passive filters

Passive filter solutions are additional filters that are added on the supply (line) side of the drive. Modern designs consist of an inductor-capacitor-inductor design that is tuned to target a specific harmonic frequency. The performance of passive harmonic filters varies from manufacturer to manufacturer, with some designs providing poor harmonic mitigation at partial loads, or when there is already existing voltage distortion on the power supply. Typical performance of passive harmonic filters result in a current distortion between 5 and 10 percent.

Passive filters are known to create a leading power factor at partial loads. Most manufacturers offer an optional contactor that removes the filter’s capacitor banks at partial loads. This contactor is highly recommended for any filters that could be powered from a generator source, as generators can become unstable when loads draw a leading power factor current. The capacitor in a passive harmonic filter has also been known to interact with other capacitors in an electrical network, such as the capacitors found in power factor correction banks, or the capacitors in a drive. These capacitor interactions can lead to nuisance electrical problems.

Passive filters may be offered separately as a stand-alone filter, provided in its own enclosure, meant to be wired next to the drive. Supplying and mounting the filter separately requires additional coordination during the design and construction phase of a project. Coordination examples include:

- Space must be allocated for installation location of each filter.
- Budgets should include additional labor for installation and wiring of the filter.
- Care must be taken when installing the passive

filter to a drive. There is a possibility to confuse passive filter with dV/dt filter, and then the filter is installed in the wrong side of the drive.

- Additional filter wiring must be completed if the drive includes a bypass. The filter should not be in the electrical path during bypass mode, thus the filter must be wired into the drive-only path, and not in the bypass path. This adds additional complexity that may not be understood by the installer.
- If the filter capacitor is to be switched off at partial load, a power source and additional wiring between the drive and the contactor coil will need to be provided, and the connections detailed for the installer.

Active filters

An active harmonic filter works like noise-cancelling headphones. The active filter takes measurements that detect the current distortion, and then supplies a counter-waveform to cancel out the distortion. The active harmonic mitigation is effective, normally achieving harmonic current distortion levels between 4 percent and 7 percent.

There are several challenges in properly applying active harmonic filter solutions. They have a large footprint and require external current sensors.

06 Six-pulse drive with passive filter

07 Six-pulse drive with active filter

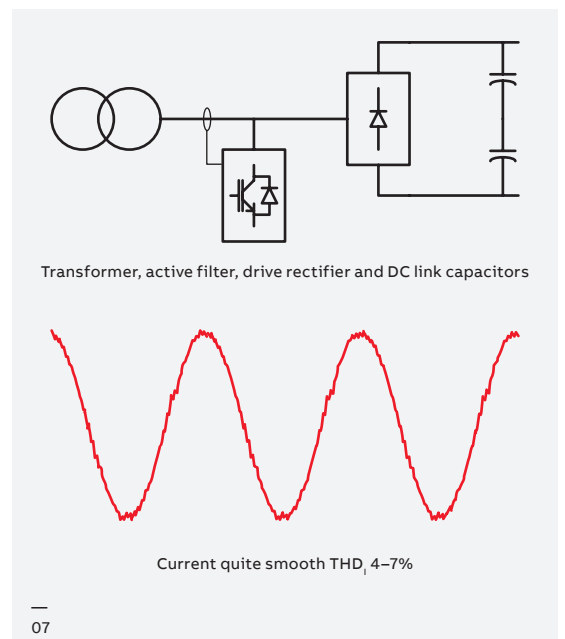
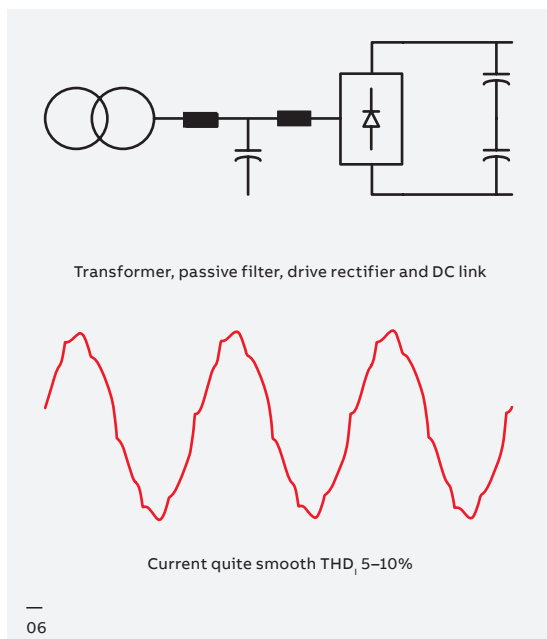

These filters are sized to clean up a specified amount of harmonic current (Amps) from the system. Due to the large size and cost of active filters, they are normally installed as a whole, or for a group of drives, and of course, this fixes the problem at that particular point, but it does not help devices inside the utility or elsewhere that are affected by harmonics. There is also some risk with this solution as a single point of failure, because if this one filter fails, the harmonic levels seen upstream will increase significantly.

Multi-pulse solutions

Multi-pulse solutions are another method of mitigating harmonics. A standard drive is six-pulse, and low-voltage multi-pulse packages are typically 12-pulse or 18-pulse designs. There are 24-pulse designs and higher also available, but those are typically found on medium-voltage drives. The total number of rectifier diodes included in the package is the same as the “pulse” number. Multi-pulse packages have the largest footprint of all standalone harmonic-mitigating solutions because of all the hardware required. An 18-pulse package for example, includes a six-pulse drive, 12 additional diodes, balancing reactors, 18 fuses, special pre-charge circuitry, a considerable amount of power wiring

connecting these components together, and a large transformer. A relatively “small” 23-amp, 18-pulse package is approximately the same size as a refrigerator, due to the transformer and all of the hardware that makes up that package. An 18-pulse package starts out by taking three-phase input voltage, and uses the phase shifting transformer to create a total of nine phases. The VFD draws power across nine phases instead of three, resulting in a smaller amount of current drawn from each of those (nine) separate phases. The current distortion of an 18-pulse is between 5 percent and 8 percent. The current distortion of a 12-pulse is between 10 percent and 12 percent.

The multi-pulse current distortion values listed above assume perfectly balanced voltage applied to the drive. A small, 2-percent voltage imbalance to the drive can result in a 50-percent increase in its current distortion. Also due to all the additional hardware, these packages are among the least energy-efficient packages on the market. Multi-pulse packages are one of the original solutions for harmonic mitigation that dates back over 30 years. But due to size, and their requirement for perfectly balanced power, this harmonic mitigation technology is becoming less common.

—
08 Standard six-pulse compared to multi-pulse solutions (six-pulse rectifier, 12-pulse rectifier, 18-pulse rectifier)

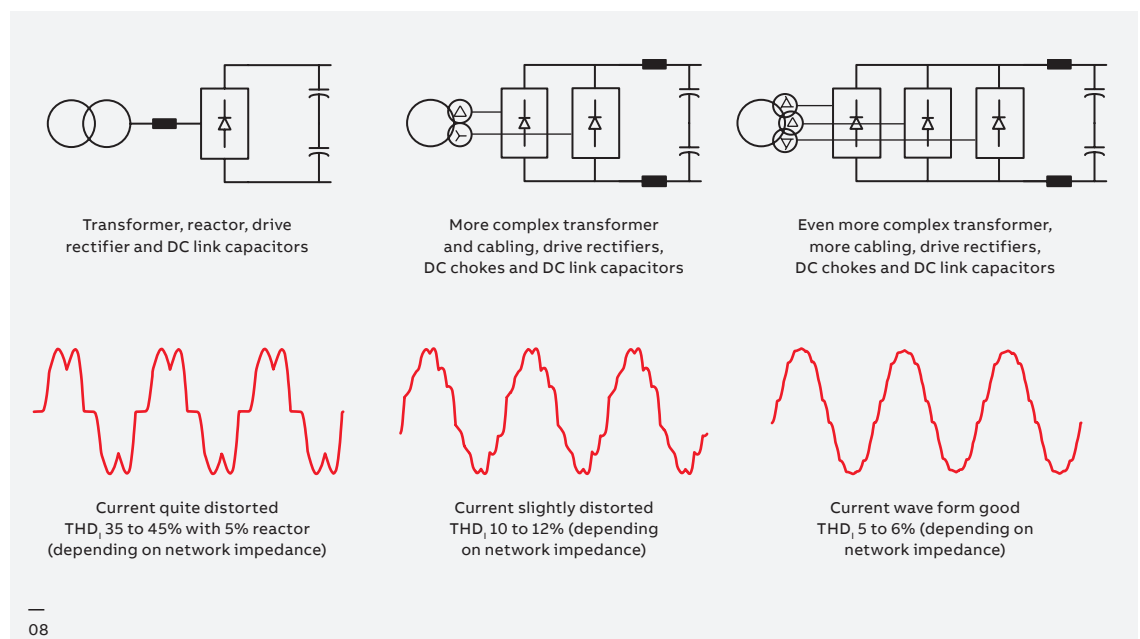

Active front end

In an active front end (AFE) drive, the rectifier consists of insulated gate bipolar transistor (IGBT) devices instead of diodes. The AFE drive also includes a built-in LCL (inductor-capacitor-inductor) filter. The IGBT-based rectifier is controlled in a way that allows the drive to draw nearly pure sinusoidal current. The LCL filter helps remove any high-frequency noise created by the IGBT switching. An LCL filter is generally preferred over a less effective LC filter. With the combination of an IGBT rectifier and LCL filter, ABB AFE drives have a current distortion between 3 percent and 5 percent, and are also known as ULH (ultra-low harmonic) drives.

The AFE is the most compact of any solution that can achieve a current distortion below 3 percent. The true power factor is unity, which means that it uses the least amount of reactive current possible. Also, AFE drives have excellent harmonic performance at partial loads. Installation of an AFE drive is simple, as they are traditionally built as a single piece of equipment with line input terminals and motor output terminals. Due to the active control of the IGBT front end, the AFE drive is more immune to voltage imbalance than any other harmonic mitigation solution.

Other mitigation technologies

There are other ways to mitigate harmonics, such as drives with an undersized DC bus capacitor and matrix technology drives, but ABB does not recommend using them. A previous section on six-pulse drive, no reactor, references drives with undersized DC bus capacitors. The paragraph below briefly covers matrix drives.

Matrix technology consists of drives that have nine bi-directional IGBTs and no DC bus capacitors, which means that input AC voltage is converted directly to an output AC voltage. While the concept sounds promising, there are significant technical limitations to the matrix drive. Matrix drives are unable to provide full output voltage, while providing optimal harmonic mitigation. When a matrix drive is configured to have optimal harmonic mitigation (almost as good as an AFE drive), the output voltage is limited to only 87 or 93 percent. Limiting the voltage to the motor would cause its motor to draw more current at full speed and full load, leading to an overheated motor. The output voltage can be configured to go higher than 87 percent, but then the current distortion also needs to increase. The matrix solution allows either good harmonic mitigation, or full control of the output voltage, but not both at the same time. The typical current distortion level is from 5 percent to 13 percent, depending on whether it is configured to provide limited or full output voltage.

—
09 Active front end
drive with LCL filter

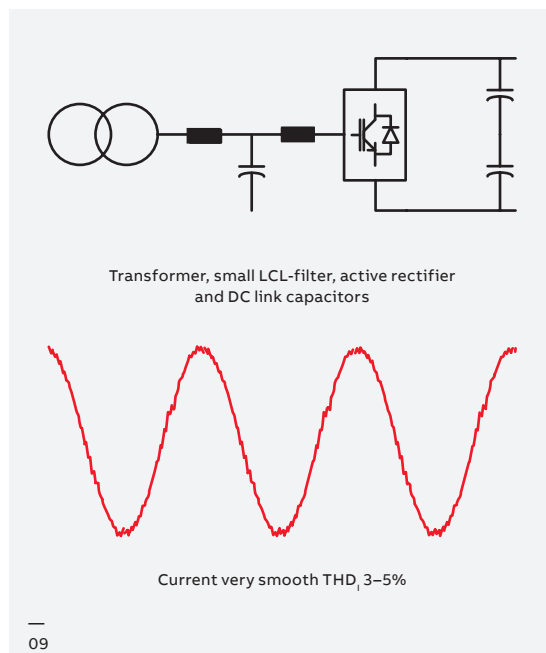



Summary

It is important to pay attention to harmonic levels in the network, since it will pay you back in the long run. THD_v is the total harmonic distortion of the voltage, and THD_i is the total harmonic distortion of the current. THD_v has the greatest impact on the end-users' power quality. However THD_i is the easiest way to compare different harmonic mitigation solutions. The current harmonics (THD_i) are responsible for creating the voltage harmonics (THD_v), and thus it is acceptable that in this document, we only compared different mitigation technologies based on current harmonics (THD_i). Harmonic distortion creates a variety of problems within a utility, but the most common problem is additional heat. As devices run hotter, they run less efficiently, age faster and are prone to premature failure.

There is no "one size fits all" solution in the mitigation of harmonics. However, there are rules of thumb that can help provide some direction for the typical cases with harmonics.

- On projects where drives make up less than 30 percent of the transformer's capacity, using six-pulse drives with properly sized chokes will be acceptable.
- On projects with more drive loading, a combination of six-pulse drives (on the smaller drives) and AFE drives (on the larger drives) will be the optimal system solution.
- On projects where backup generators are required, system reliability can be improved and generator oversizing can be avoided by using AFE drives.

A computer-simulated harmonic analysis is recommended for any project that has a considerable amount of non-linear loading. The harmonic analysis will identify the harmonic levels and show the impact of upgrading to additional harmonic mitigation (such as an AFE), if required. ABB can help with a harmonic analysis of your project.



—
For more information, please contact
your local ABB representative or visit

new.abb.com/drives/harmonics

new.abb.com/drives

new.abb.com/drives/drivespartners

