

Original instructions

MKey5-series

Safety Interlock Switch

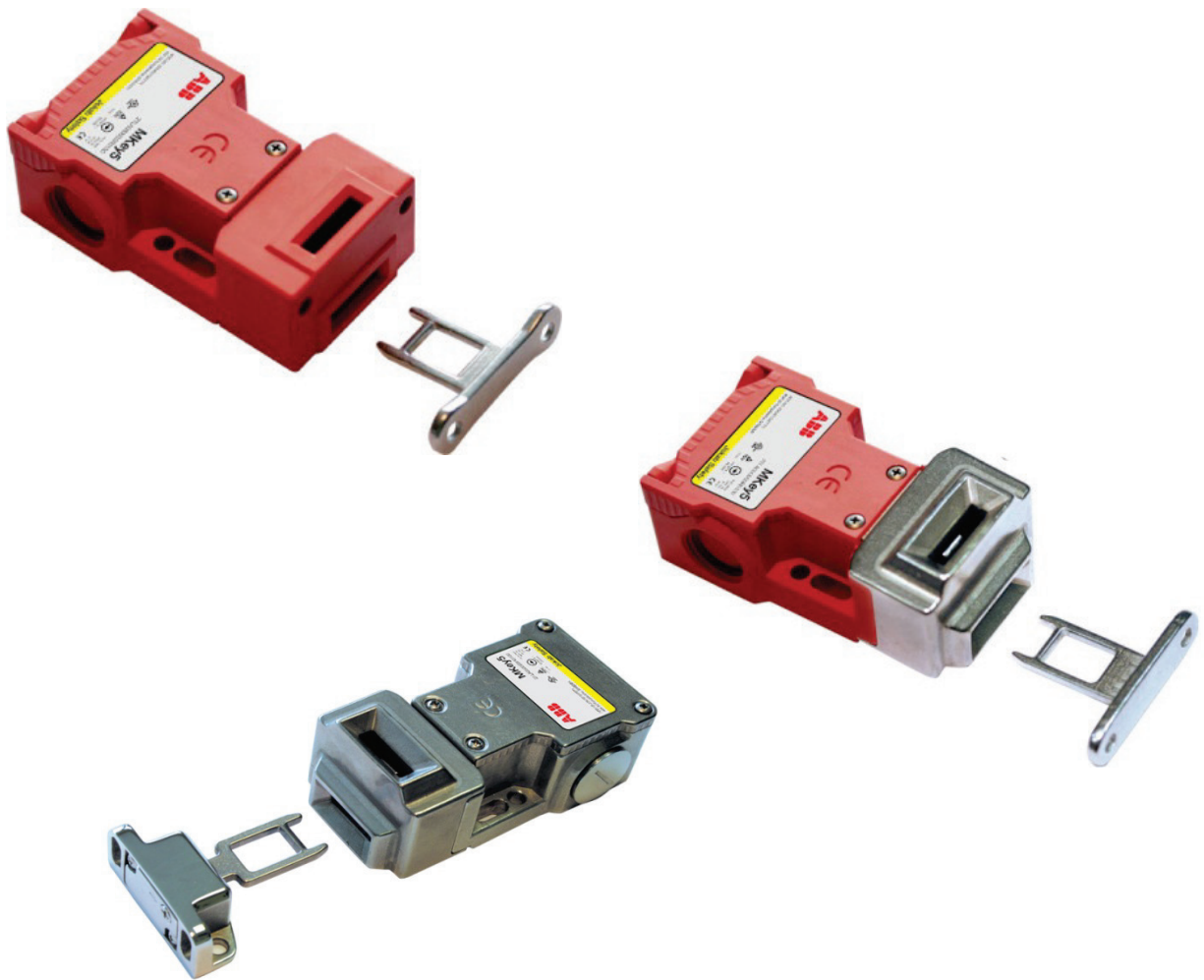

Read and understand this document

Please read and understand this document before using the products. Please consult your ABB/JOKAB SAFETY representative if you have any questions or comments.

WARRANTY

ABB/JOKAB SAFETY's exclusive warranty is that the products are free from defects in materials and workmanship for a period of one year (or other period if specified) from date of sale by ABB/JOKAB SAFETY.

ABB/JOKAB SAFETY MAKES NO WARRANTY OR REPRESENTATION, EXPRESSED OR IMPLIED, REGARDING NON-INFRINGEMENT, MERCHANTABILITY, OR FITNESS FOR PARTICULAR PURPOSE OF THE PRODUCTS, ANY BUYER OR USER ACKNOWLEDGES THAT THE BUYER OR USER ALONE HAS DETERMINED THAT THE PRODUCTS WILL SUITABLY MEET THE REQUIREMENTS OR THEIR INTENDED USE. ABB/JOKAB SAFETY DISCLAIMS ALL OTHER WARRANTIES, EXPRESSED OR IMPLIED.

LIMITATIONS OF LIABILITY

ABB/JOKAB SAFETY SHALL NOT BE RESPONSIBLE FOR SPECIAL, INDIRECT, OR CONSEQUENTIAL DAMAGES, LOSS OF PROFITS OR COMMERCIAL LOSS IN ANY WAY CONNECTED WITH THE PRODUCTS, WHETHER SUCH CLAIM IS BASED ON CONTRACT, WARRANTY, NEGLIGENCE, OR STRICT LIABILITY.

In no event shall responsibility of ABB/JOKAB SAFETY for any act exceed the individual price of the product on which liability asserted.

IN NO EVENT SHALL ABB/JOKAB SAFETY BE RESPONSIBLE FOR WARRANTY, REPAIR, OR OTHER CLAIMS REGARDING THE PRODUCTS UNLESS ABB/JOKAB SAFETY'S ANALYSIS CONFIRMS THAT THE PRODUCTS WERE PROPERLY HANDLED, STORED, INSTALLED, AND MAINTAINED AND NOT SUBJECT TO ABUSE, MISUSE, OR INAPPROPRIATE MODIFICATION OR REPAIR.

SUITABILITY FOR USE

ABB/JOKAB SAFETY shall not be responsible for conformity with any standards, codes, or regulations that apply to the combination of products in the customer's application or use of the product. At the customer's request, ABB/JOKAB SAFETY will provide applicable third party certification documents identifying ratings and limitations of use that apply to the products. This information by itself is not sufficient for a complete determination of the suitability of the products in combination with the end product, machine, system, or other application or use.

The following are some examples of applications for which particular attention must be given. This is not intended to be an exhaustive list of all possible uses of the products, nor is it intended to imply that the uses listed may be suitable for the products:

Outdoor use, uses involving potential chemical contamination or electrical interference, or conditions or uses not described in this document.

Nuclear energy control systems, combustion systems, railroad systems, aviation systems, medical equipment, amusement machines, vehicles, and installations subject to separate industry or government regulations.

Systems, machines, and equipment that could present a risk to life or property.

Please know and observe all prohibitions of use applicable to the products.

NEVER USE THE PRODUCTS FOR AN APPLICATION INVOLVING SERIOUS RISK TO LIFE OR PROPERTY WITHOUT ENSURING THAT THE SYSTEM AS A WHOLE HAS BEEN DESIGNED TO ADDRESS THE RISKS, AND THAT THE ABB/JOKAB SAFETY PRODUCT IS PROPERLY RATED AND INSTALLED FOR THE INTENDED USE WITHIN THE OVERALL EQUIPMENT OR SYSTEM.

PERFORMANCE DATA

While every effort has been taken to ensure the accuracy of the information contained in this manual ABB/JOKAB SAFETY cannot accept responsibility for errors or omissions and reserves the right to make changes and improvements without notice. Performance data given in this document is provided as a guide for the user in determining suitability and does not constitute a warranty. It may represent the result of ABB/JOKAB SAFETY'S test conditions, and the users must correlate it to actual application requirements. Actual performance is subject to the ABB/JOKAB SAFETY Warranty and Limitations of Liability.

Table of Contents

1	Introduction	4
	Scope	4
	Audience	4
	Prerequisites	4
	Special notes	4
2	Overview	5
	General description.....	5
	Safety regulations	5
	Function description.....	6
3	Connections	7
4	Installation and maintenance	8
5	Application examples.....	10
6	Model overview.....	11
	Dimensions	11
	Accessories.....	11
	Actuators	12
	Dimensions	12
7	Technical data	13
8	EC Declaration of conformity	15

1 Introduction

Scope

The purpose of these instructions is to describe the safety interlock switch MKey5-series, and to provide the necessary information required for assembly, installation, checks and adjustments after installation, and maintenance. The instructions also include information necessary to connect MKey5 to a safety circuit.

Audience

This document is intended for authorized installation personnel.

Prerequisites

It is assumed that the reader of this document has knowledge of the following:

- Basic knowledge of ABB/Jokab Safety products.
- Knowledge of safety devices and safety locks.
- Knowledge of machine safety.

Special notes

Pay attention to the following special notes in the document:

 **Warning!** Danger of severe personal injury!
An instruction or procedure which, if not carried out correctly, may result in injury to the technician or other personnel.

Caution! Danger of damage to the equipment!
An instruction or procedure which, if not carried out correctly, may damage the equipment.

NB: Notes are used to provide important or explanatory information.

2 Overview

General description

MKey5 interlock switches are designed to provide position interlock detection for moving guards. They are designed to fit the leading edge of sliding, hinged or lift off machine guards. The actuator is fitted to the moving part of the guard and is aligned to the switch entry aperture.

Safety regulations

Warning!

Carefully read through this entire manual before using the device.

The devices shall be installed by a trained electrician following the Safety regulations, standards and the Machine directive.

Failure to comply with instructions, operation that is not in accordance with the use prescribed in these instructions, improper installation or handling of the device can affect the safety of people and the plant.

For installation and prescribed use of the product, the special notes in the instructions must be carefully observed and the technical standards relevant to the application must be considered.

In case of failure to comply with the instructions or standards, especially when tampering with and/or modifying the product, any liability is excluded.

Function description

Safety interlock switches are designed to fit to the leading edge of sliding or hinged guard doors to provide positively operated switching contacts and provide a tamper resistant key mechanism. They are designed to provide robust position interlock detection and keep moving guards closed. The switch is rigidly mounted to the frame of the guard or machine. The actuator is fitted to the moving part of the guard, and is aligned to the switch entry aperture, placed on the frame of the guard. The actuator profile is designed to match a cam mechanism within the switch head and provides a positively operated not easily defeat able interlock switch. When the guard is closed and the actuator inserted in the switch, the machine can be able to start. When the actuator is withdrawn the safety contacts are positively opened and the machine circuit is broken.

Depending on the environment where the switch will be used, different materials can be chosen on the MKey5. The basic version is in a full plastic body (polyester) and in cases where the demands are higher on the interlock switch head; there is a version with a plastic body and with a stainless steel head. Both these types give the MKey5 interlock switch a rating of IP67. In harsh applications as for food processing and chemical industry there is a MKey5 interlock switch with a total rugged stainless steel 316 body. This version has IP69K enclosure protection (maintained by a double seal lid gasket) and can be high pressure hosed with detergent at high temperature.

A positive forced contact provides a forced disconnect of the safety contacts at the withdrawal of the actuator. The design of the MKey5 ensures that the contacts will not fail or be held in a normally closed position, due to failure of the spring mechanism or that welding/sticking of the contacts can occur.

The positive forced disconnect contacts gives a high safety level and the interlock switch has an anti-tamper mechanism. To achieve highest safety level in connection with the machine control system it is recommended that the MKey5 is monitored by an appropriate ABB Jokab Safety safety relay, Pluto safety PLC or Vital system. To obtain the highest level of safety, two switches per gate are required.

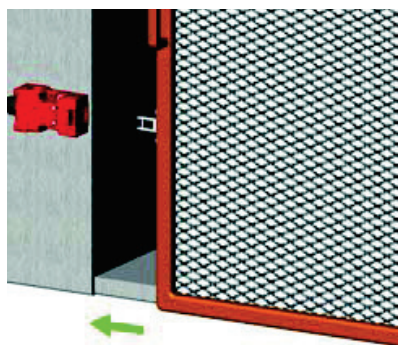

Sliding door

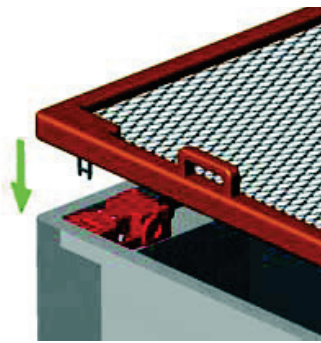

Lift off guard

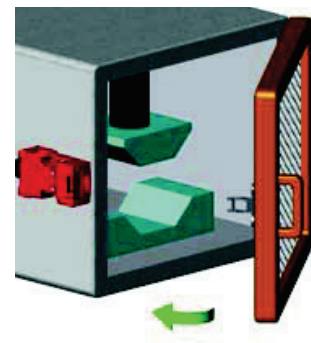

Hinged guard

Warning! Application consideration must be given to the fixing of the actuator which has to be in a way that prevents disassembly by easy means.

The head can be rotated to provide four given actuator entry positions (2). MKey5 has several types of actuators as options. A standard actuator key is always delivered with interlock switches.

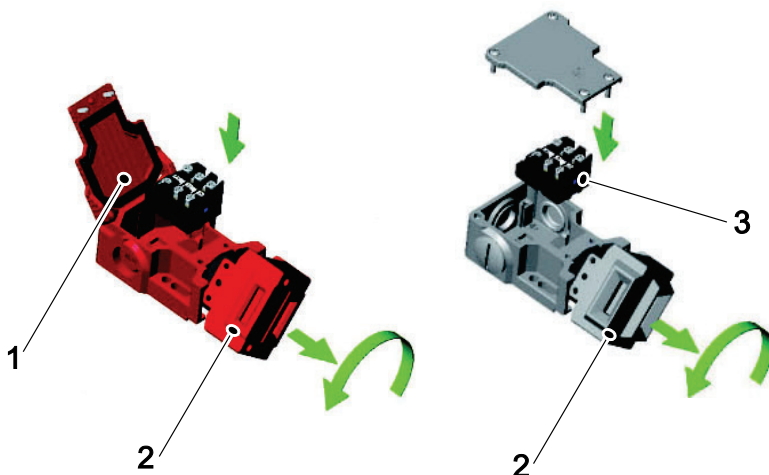

- 1) Hinged lid
- 2) Rotating head
- 3) Replaceable contact blocks

Note! The switch should not be used

3 Connections

See Chapter Installation and Maintenance for more information regarding installation.

Connections



Contact block - Configuration 2 NC, 1 NO

The normally closed contacts (11/12, 21/22) are positively force disconnected, and normally used for the safety function. The overlapping, normally open contacts (33/34) enables operational status indication of e.g. incorrect adjustment of switch before the positive forced disconnect NC contacts open.

NB: Contacts considered in “normal” state when the guard is closed, i.e. the state required for a machine to be allowed to start.

MKey5, explosion proof

2NC

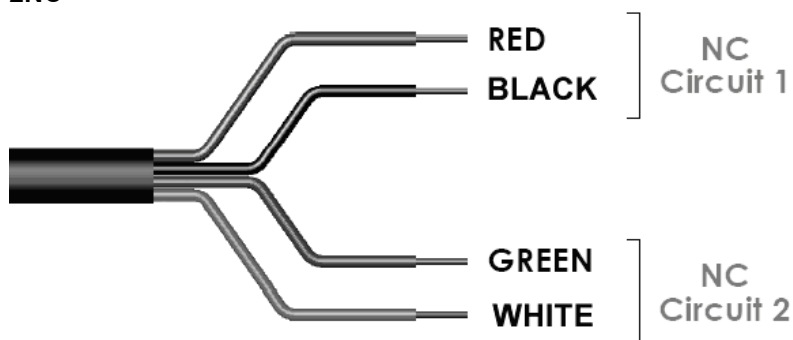

Actuator insertion

2NC INC 6.80 6 0 mm

11/12	Open	
21/22	Open	
33/44		Open

MKey5, Contacts at withdrawal of actuator.

4 Installation and maintenance

Installation and maintenance

1. The installation of all ABB/Jokab Safety interlock switches must be in accordance with a risk assessment for the individual application. Installation must only be carried out by competent personnel and in accordance with these instructions.
2. M5 mounting bolts must be used to fix the switch and actuator, the tightening torque to ensure reliable fixing is 4.0 Nm. To prevent loosening of the switch after installation, always fix the M5 mounting bolts with a thread-locking compound or secure using self locking nuts. Tightening torque for the lid screws, conduit entry plugs and cable glands must be 1.5 Nm to ensure IP seal.

Only use the correct size gland for the conduit entry and cable outside diameter.

Tightening torque for the connection terminal screws is 1.0 Nm, max conductor size is 2.5 mm². The switch head position can be rotated by opening the lid and then pulling the end cover away from the switch and then rotating to the position required.

3. Always fit a mechanical stop to the guard to prevent damage to the front of the switch.

Set the actuator gap to 3 mm when the guard is closed and against the stop. (See illustration).

Use alignment guides to ensure that the actuator enters the switch without interfering with the sides of the aperture.

Always fit the aperture plug to the unused entry aperture to prevent debris entering the switch mechanism.

4. After installation check operation of all control circuits ensuring that when the actuator is out of the switch, the machine cannot be started.

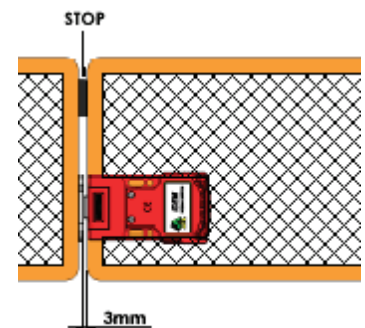

Warning! All the safety functions must be tested before starting up the system.

Maintenance

Every week: Check correct operation of all circuits. If the actuator shows signs of bending or the switch head housing displays mechanical damage then remove and replace.

Every 6 months: Isolate power and remove cover. Check screw terminal tightness and check for signs of moisture ingress. Never attempt to repair any switch.

Warning! The safety functions and the mechanics shall be tested regularly, at least once every year to confirm that all the safety functions are working properly.

Warning! In case of breakdown or damage to the product, contact the nearest ABB/Jokab Safety Service Office or reseller. Do not try to repair the product yourself since it may accidentally cause permanent damage to the product, impairing the safety of the device which in turn could lead to serious injury to personnel.

Caution! ABB/Jokab Safety will not accept responsibility for failure of the switch functions if the installation and maintenance requirements shown in this sheet are not implemented. These requirements form part of the product warranty.

Minimum safety distance

When using interlocking guards without guard locking to safeguard a hazard zone, the minimum allowed safety distance between the guarded opening and the hazardous machine must be calculated. In order to ensure that the hazardous machine motion will be stopped before it can be reached, the minimum safety distance is calculated according to EN ISO 13855 ("Positioning of safeguards with respect to the approach speeds of parts of the human body").

The minimum safety distance is calculated according to the formula:

$$S = (K \times T) + C$$

Where

S = minimum safety distance (mm)

K = approach speed of a human body; 1600 mm/s

T = the total time from opening of the guard until the hazardous machine movement has stopped, i.e. including control system reaction times and other delays (s)

C = a safety distance taken from Table 4 or Table 5 of EN ISO 13857:2008, if it is possible to push fingers or a hand through the opening towards the hazard before a stop signal is generated

In some cases, T might be reduced by the opening time of the guard until the opening size permits access of the relevant parts of the body. Refer to EN ISO 13855 for further details and EN ISO 13857 for specified values.

5 Application examples

Application example

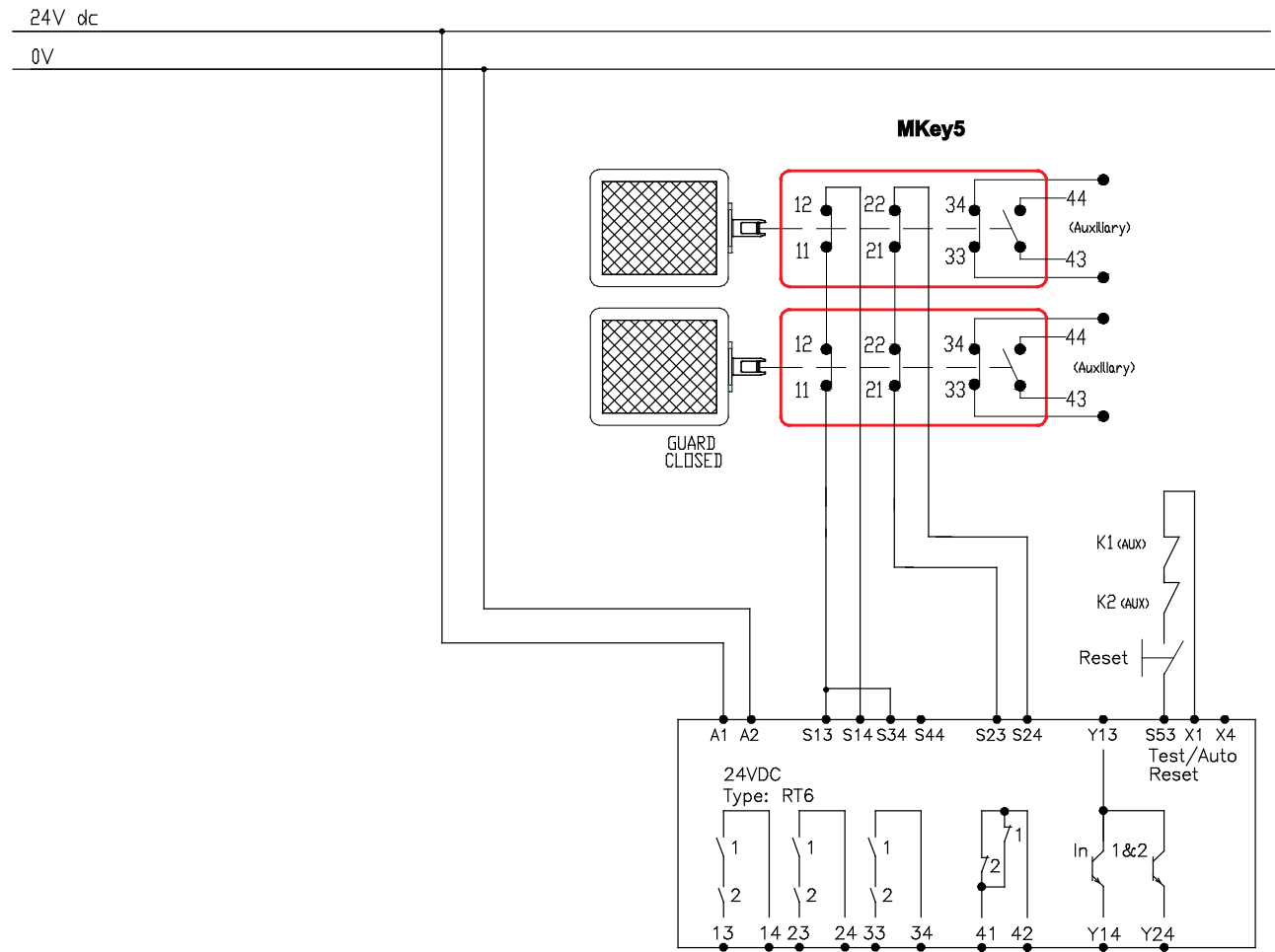

6 Model overview

Type	Article number	Description
MKey5	2TLA050003R0100	M20, 2NC/1NO, 12N, Standard Key
MKey5+	2TLA050003R0101	M20, 2NC/1NO, 40N, Standard Key
MKey5	2TLA050003R0110	M20, 2NC/1NO, 12N, Stainless steel head, Standard Key
MKey5+	2TLA050003R0111	M20, 2NC/1NO, 40N, Stainless steel head, Standard Key
MKey5Z	2TLA050003R0120	M20, 2NC/1NO, 12N, Stainless steel, Standard Key
MKey5+Z	2TLA050003R0121	M20, 2NC/1NO, 12N, Stainless steel, Standard Key
MKey5ZX	2TLA050003R0125	2NC, 3m cable, 2NC, 12N, Stainless steel, Standard Key, Explosion proof

Dimensions

MKey5

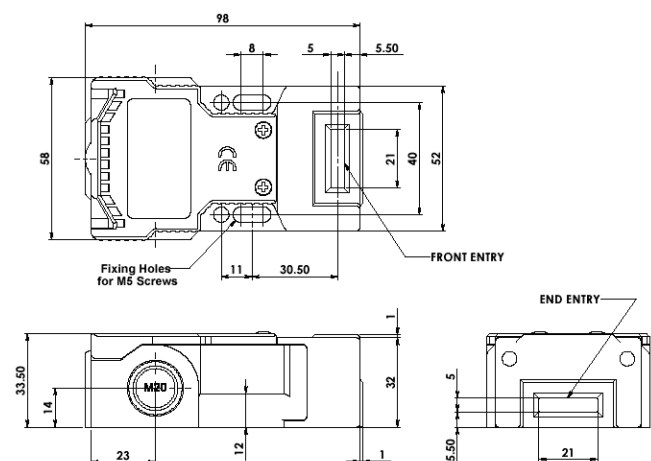

MKey5Z

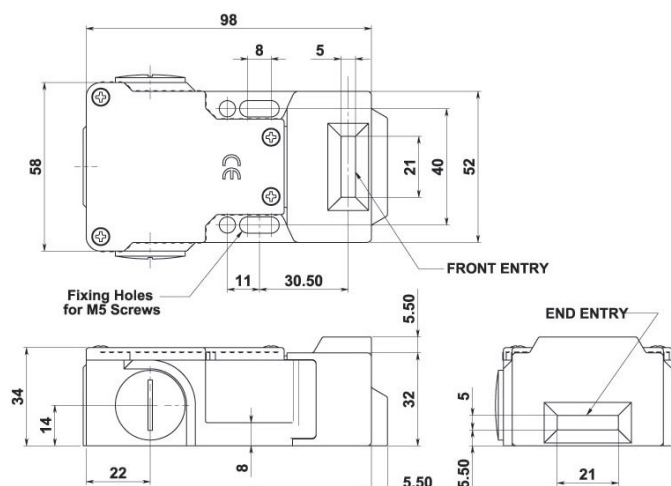

NB: All measurements in millimetres.

Accessories

Type	Article number	Description
Gland	2TLA050040R0002	Stainless steel cable gland
Tina 2A	2TLA020054R0100	Adaptation unit for dynamic circuit with M20 fitting.
Tina 2B	2TLA020054R1100	Adaptation unit for dynamic circuit, internal assembly.
Tina 3A	2TLA020054R0200	Adaptation unit for dynamic circuit with M20 fitting and M12 connector
Lockout Actuator	2TLA050040R0401	Lockable service key for maintenance

Actuators

All keys are in stainless steel.

Type	Article number	Description
1	2TLA050040R0201	Standard key for plastic head
2	2TLA050040R0202	Standard key for SS head
3	2TLA050040R0220	Flat key
4	2TLA050040R0221	Flexible key with plastic housing
5	2TLA050040R0203	Flexible key with metal housing
6	2TLA050040R0204	Flexible key with SS housing

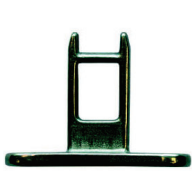

1



2



3



4

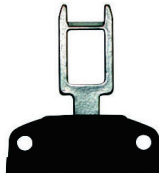

5



6

Dimensions

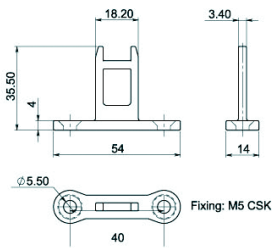

1

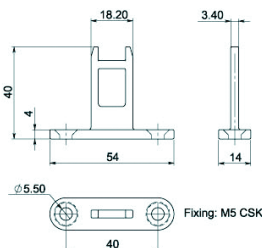

2

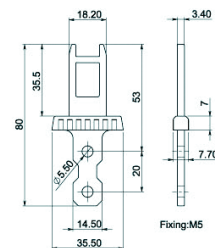

3

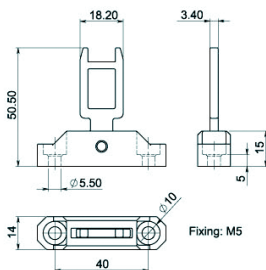

4

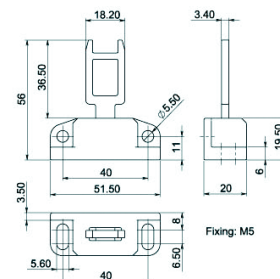

5/6

NB: All measurements in millimetres.

7 Technical data

Manufacturer

Address	ABB AB / JOKAB SAFETY Varlabergsvägen 11 SE-434 39 Kungsbacka Sweden
---------	---

Electrical characteristics

Utilization category	AC-15 A300 3A
Thermal Current (I _{th})	10 A
Rated insulation/withstand voltages	500 VAC/2500 VAC

Explosion Proof version (X)

Classification	Ex d IIC T6 (-20°C ≤ Ta ≤ +60°C) Gb Ex tb IIIC T85°C (-20°C ≤ Ta ≤ +60°C) Db
Rated Voltage	250V AC/DC
Rated Current	2 pole 4A

General

Travel for positive opening	6 mm
Actuator entry minimum radius	Standard actuator: 175 mm Flexible actuator: 100 mm
Protection class	MKey5: IP67 MKey5Z: IP69K
Ambient temperature	-25...+80°C
Size	See drawing
Cable entry	3 x M20 x 1.5
Material	MKey5: Body: Polyester Head: Polyester or stainless steel 316 MKey5Z: Body: Stainless steel Head: Stainless steel
Fixing	Body: 2 x M5 Actuator: 2 x M5
Maximum approach / withdrawal speed	600 mm/s
Holding force	MKey5: 12 N MKey5+: 40 N
Vibration	IEC 68-2-6, 10-55 Hz+1 Hz, Excursion: 0.35 mm, 1 octave/min

Safety-related characteristic data and Conformity

Conformity	European Machinery Directive 2006/42/EC EN ISO 12100:2010, EN 1088:1995+A2:2008, EN 60204-1:2006+A1:2009 EN 60947-1:2007+A1:2011, EN 60947-5-1:2004+A1:2009
EN ISO 13849-1	Up to PL e, cat. 4 depending on system architecture
EN 62061	Up to SIL3 depending on system architecture
Safety data	
B _{10d}	2,500,000 operations at 100 mA load
MTTF _d	356 years (8 cycles per hour/24 hours per day/365 days per year)
Proof test interval (Life)	35 years
Certifications	TÜV, cULus
Information with regard to UL 508	Use 12AWG copper conductors only Electrical Rating: A300 48W5 Type 1 Enclosure Max. Switching Current / Volt / Amp: 120V 6A (720VA break) PF 0.38, 240V 3A (720VA break) PF 0.38

NB: A single MKey5 can achieve performance level PL c according to EN ISO 13849 if used correctly with an ABB/Jokab Safety safety relay, Pluto safety-PLC or Vital safety module. If two MKey5-switches are used for the same safety function, a performance level up to PL e can be achieved. Refer to EN ISO 13849 for details on how to achieve this if necessary.

The Jokab Safety branded product with articlenumber beginning with 2TLJ is fully compatible with the ABB branded product with articlenumber beginning with 2TLA.

8 EC Declaration of conformity



EC Declaration of conformity

(according to 2006/42/EC, Annex 2A)

<p>We ABB AB JOKAB Safety Varlabergsvägen 11 SE-434 39 Kungsbacka Sweden</p>	<p>declare that the safety components of ABB AB manufacture with type designations and safety functions as listed below, is in conformity with the Directives 2006/42/EC 2006/95/EC</p>
--	---

<p>Authorised to compile the technical file</p>	<p>ABB AB JOKAB Safety Varlabergsvägen 11 SE-434 39 Kungsbacka Sweden</p>
---	---

Product

Safety interlock switches

MKey1	MKey2	MKey4
MKey4+	MKey5	MKey5+
MKey5+Z	MKey5Z	MKey6
MKey6+	MKey 6+Z	MKey6Z
MKey8	MKeyER	MKey8ERZ
MKey8M	MKey8Z	MKey 9
MKey9M		

<p>Used harmonized standards</p>	<p>EN ISO 12100:2010, EN 1088:1995+A2:2008, EN 60204-1:2006:+A1:2009</p>
----------------------------------	--

<p>Other used standards</p>	<p>EN 60947-1:2007:+A1:2011, EN 60947-5-1:2004:+A1:2009</p>
-----------------------------	---



Jesper Kristensson
PRU Manager
Kungsbacka 2012-08-06

www.abb.com
www.jokabsafety.com

Original

EC Declaration of conformity

(according to 2006/42/EC, Annex 2A)

We	ABB AB JOKAB Safety Varlabergsvägen 11 SE-434 39 Kungsbacka Sweden	declare that the safety components of ABB AB manufacture with type designations and safety functions as listed below, is in conformity with the Directives 2006/42/EC 2006/95/EC 94/9/EC
Authorised to compile the technical file	ABB AB JOKAB Safety Varlabergsvägen 11 SE-434 39 Kungsbacka Sweden	
Product	EC Type Certificate	
Safety interlock switch with explosion proof internal contact block MKey5ZX	Baseefa11ATEX0267X (94/9/EC)	
Notified Body	Baseefa Ltd, Buxton Derbyshire SK17 9RZ United Kingdom Notified Body No 1180	
Used harmonized standards	EN ISO 12100:2010, EN 1088:1995+A2:2008, EN 60204-1:2006:+A1:2009, EN 60079-0:2011, EN 60079-12:2007, EN 60079-31:2008	
Other used standards	EN 60947-1:2007:+A1:2011, EN 60947-5-1:2004:+A1:2009	



Jesper Kristensson
PRU Manager
Kungsbacka 2012-08-06

www.abb.com
www.jokabsafety.com

Original

ABB AB / JOKAB SAFETY Varlabergsvägen 11, SE-434 39 Kungsbacka, Sweden

www.abb.com/lowvoltage